

# Thermal Imaging IR Camera Model 1950

---

Quick Start Guide  
ENGLISH



*Measure up*

[www.aemc.com](http://www.aemc.com)

 **AEMC**<sup>®</sup>  
INSTRUMENTS  
CHAUVIN ARNOUX GROUP

## Statement of Compliance

Chauvin Arnoux®, Inc. d.b.a. AEMC® Instruments certifies that this instrument has been calibrated using standards and instruments traceable to international standards.

We guarantee that at the time of shipping your instrument has met its published specifications.

**An NIST traceable certificate may be requested at the time of purchase, or obtained by returning the instrument to our repair and calibration facility, for a nominal charge.**

The recommended calibration interval for this instrument is 12 months and begins on the date of receipt by the customer. For recalibration, please use our calibration services. Refer to our repair and calibration section at [www.aemc.com](http://www.aemc.com).

**Serial #:** \_\_\_\_\_

**Catalog #:** **2121.40** \_\_\_\_\_

**Model #:** **Model 1950** \_\_\_\_\_

Please fill in the appropriate date as indicated:

Date Received: \_\_\_\_\_

Date Calibration Due: \_\_\_\_\_



Chauvin Arnoux®, Inc.  
d.b.a AEMC® Instruments  
[www.aemc.com](http://www.aemc.com)



## ATTENTION



---

An infrared camera is a sensitive optical measuring device. Pay special attention to the following points:

1. Never aim the camera at the sun, a laser welding, or other source of powerful thermal radiation.
2. Avoid exposure to dust with the lens flap open.
3. Do not touch the lens with your fingers.
4. Avoid jolting or dropping the camera.

If parts of the camera are damaged or not functioning as expected following failure to heed the warnings listed above, neither the manufacturer nor the distributor shall be held liable, and all costs incurred shall be borne solely by the operator.

### Symbols used on the instrument:

	The CE marking indicates compliance with the European "Low Voltage" and "Electromagnetic Compatibility" directives (2006/95/EC and 2004/108/EC).
	In the European Union, this product is subject to selective collection and recycling at end-of-life as waste electric and electronic equipment under directive 2002/96/EC (WEEE): this equipment must not be treated as an ordinary household waste. The spent batteries must not be treated as household wastes. Take them to the appropriate collection point for recycling.
	This product is designed to allow the recovery and recycling of most of its constituents.

# ORDERING INFORMATION

---

## Receiving Your Shipment

Upon receiving your shipment, make sure that the contents are consistent with the packing list. Notify your distributor of any missing items. If the equipment appears to be damaged, file a claim immediately with the carrier and notify your distributor at once, giving a detailed description of any damage. Save the damaged packing container to substantiate your claim.

## Ordering Information

Thermal Imaging IR Camera Model 1950 .... **Cat. #2121.40**  
*Includes carrying case, external battery charger, USB cable, four NiMh rechargeable batteries, micro SD card, Bluetooth headphone, quick start guide, and a USB drive containing the user manual, analysis software and software manual.*

## Replacement Parts:

Case – Carrying Case with Foam Insert ..... **Cat. #2121.60**  
Adapter – US External Battery Charger ..... **Cat. #2121.64**  
Cable – USB (Type A to 5-pin Mini-B) ..... **Cat. #2126.49**

# 1. QUICK START STEPS

---

The following steps assume default settings:

1. Insert charged batteries in the camera (if not already installed).
2. Insert the micro SD memory card into its slot.
3. Open the flap protecting the lenses.
4. Press the ON/OFF key:
  - If you have installed new batteries, configure Battery Manager (see instructions in the User Manual § 1.2.1).
  - If prompted, enter the date and time.
5. Aim at the target. An IR image (thermogram) of the target appears in the display.
6. To save the thermogram and its associated visible light image, press F2 to freeze the image and then press F3. The images are saved in a file in the micro SD card.
7. You can recall and view saved images on the camera, or transfer images to a computer (using the USB cable or a micro SD card reader) for analysis and report generation with the provided CAMReport software.

NOTE: For more information, refer to the User Manual on the USB drive.

## 2. FRONT VIEW

---

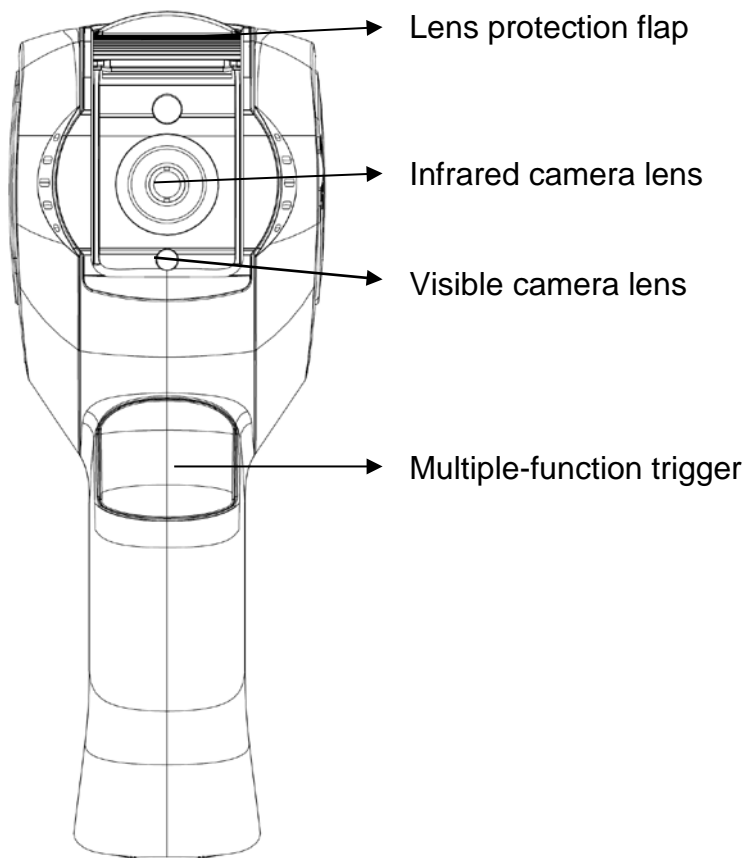

### 3. SIDE VIEW

---

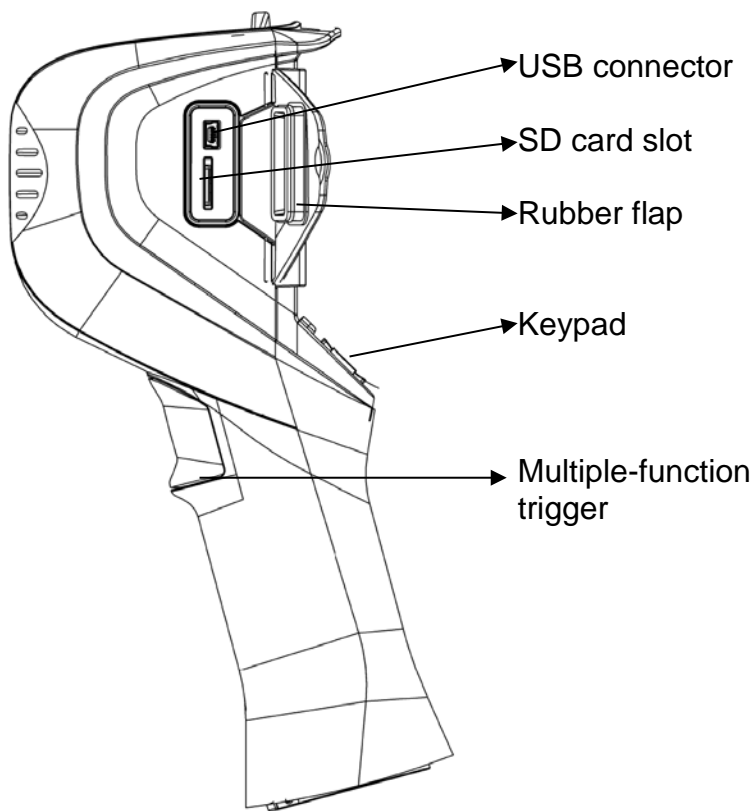

## 4. KEY FUNCTIONS

---



Multiple-function keys associated with the display on screen

ON/OFF key

Up/Down/Right/Left Arrow navigation keys



# 5. BATTERY COMPARTMENT COVER

---

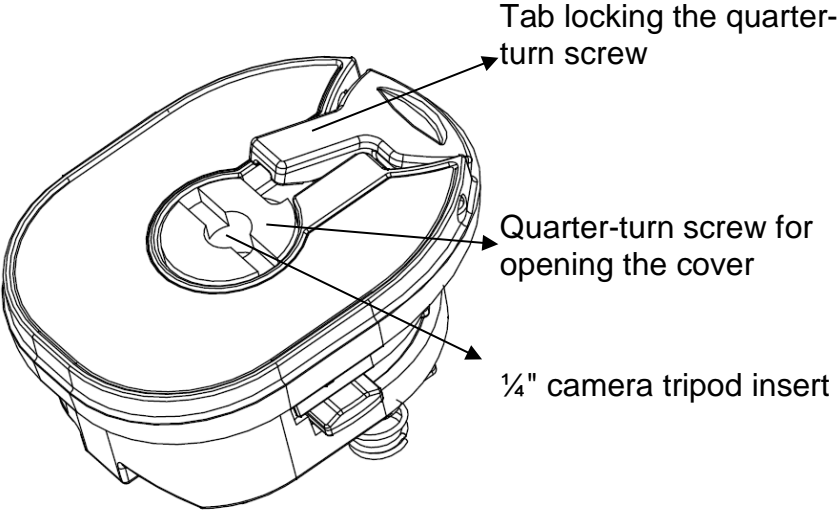

## 6. DISPLAY



## 7. STATUS BAR

---

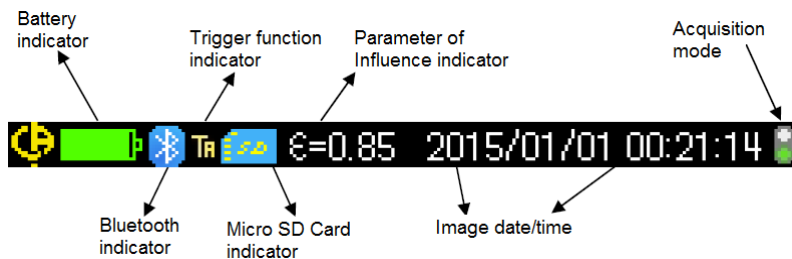



Chauvin Arnoux<sup>®</sup>, Inc. d.b.a AEMC<sup>®</sup> Instruments  
15 Faraday Drive • Dover, NH 03820 USA  
[www.aemc.com](http://www.aemc.com)

## Free Manuals Download Website

<http://myh66.com>

<http://usermanuals.us>

<http://www.somanuals.com>

<http://www.4manuals.cc>

<http://www.manual-lib.com>

<http://www.404manual.com>

<http://www.luxmanual.com>

<http://aubethermostatmanual.com>

Golf course search by state

<http://golfingnear.com>

Email search by domain

<http://emailbydomain.com>

Auto manuals search

<http://auto.somanuals.com>

TV manuals search

<http://tv.somanuals.com>