

HITACHI

SERVICE MANUAL

SM0547

CP-S335W (C9SM)
CP-X340W/F (C9X)
CP-X345W/F (C9XM)
PJ552 (C9X)
PJ562 (C9XM)

Warning

The technical information and parts shown in this manual are not to be used for: the development, design, production, storage or use of nuclear, chemical, biological or missile weapons or other weapons of mass destruction; or military purposes; or purposes that endanger global safety and peace. Moreover, do not sell, give, or export these items, or grant permission for use to parties with such objectives. Forward all inquiries to Hitachi Ltd.

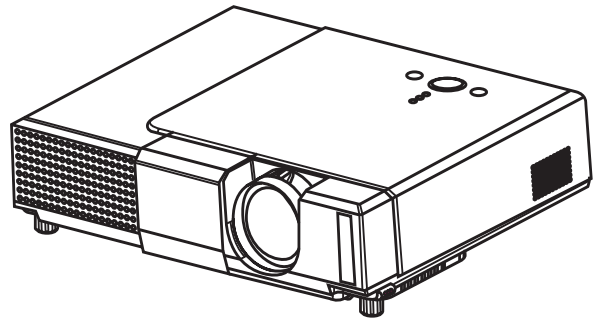

Caution

Be sure to read this manual before servicing. To assure safety from fire, electric shock, injury, harmful radiation and materials, various measures are provided in this Hitachi Multimedia LCD Projector. Be sure to read cautionary items described in the manual to maintain safety before servicing.

Service Warning

1. When replacing the lamp, avoid burns to your fingers. The lamp becomes very hot.
2. Never touch the lamp bulb with a finger or anything else. Never drop it or give it a shock. They may cause bursting of the bulb.
3. This projector is provided with a high voltage circuit for the lamp. Do not touch the electric parts of power unit (main), when turn on the projector.
4. Do not touch the exhaust fan, during operation.
5. The LCD module assembly is likely to be damaged. If replacing the LCD LENS/PRISM assembly, do not hold the FPC of the LCD module assembly.
6. Use the cables which are included with the projector or specified.

Contents

| | | | |
|-----------------------------|----|---------------------------------------|----|
| 1. Features | 2 | 8. Disassembly diagram | 36 |
| 2. Specifications | 2 | 9. Replacement parts list | 42 |
| 3. Names of each part | 3 | 10.RS-232C commands | 46 |
| 4. Adjustment | 5 | 11.Block diagram | 55 |
| 5. Troubleshooting | 12 | 12.Connector connection diagram | 56 |
| 6. Service points | 17 | 13.Basic circuit diagram | 57 |
| 7. Wiring diagram | 30 | | |

SPECIFICATIONS AND PARTS ARE SUBJECT TO CHANGE FOR IMPROVEMENT.

Multimedia LCD Projector

August 2004 Digital Media Division

1. Features

- High Brightness
- Low Noise
- Rich Connectivity
- Compact Body

2. Specifications

| | | | |
|----------------------|------------------|---------------------------------------|--|
| Liquid crystal panel | Drive system | | TFT active matrix |
| | Panel size | | 1.8 cm (0.7 type) |
| | Number of pixels | | CP-S335 : 800 (H) × 600 (V) CP-X340/CP-X345/PJ552/PJ562 : 1024 (H) x 768(V) |
| Lamp | | | 165W UHB |
| RGB signal input | RGB IN | 1 | Video: Analog 0.7Vp-p(75Ω termination) H/V. sync.: TTL level (positive/negative) Composite sync.: TTL level |
| | | 2 | |
| AUDIO IN1 | | 200mVrms, 47kΩ or more (max.3.0Vp-p) | |
| VIDEO signal input | VIDEO IN | | 1.0Vp-p (75Ω termination) |
| | S-VIDEO IN | | Y signal: 1.0±0.1Vp-p, (75Ω termination) C signal: 0.286±0.1Vp-p (NTSC burst signal, 75Ω termination) 0.3±0.1Vp-p (PAL/SECAM burst signal, 75Ω termination) |
| | COMPONENT VIDEO | Y | 1.0±0.1Vp-p, 75Ω termination (positive) |
| | | Cb/Pb | 0.7±0.1Vp-p, 75Ω termination (positive) |
| | | Cr/Pr | 0.7±0.1Vp-p, 75Ω termination (positive) |
| AUDIO IN2 | | 200mVrms, 47kΩ or more (max. 3.0Vp-p) | |
| Signal output | RGB OUT | | Video: Analog 0.7Vp-p, 75Ω output impedance (positive) H/V. sync.: TTL level (positive/negative) Composite sync.: TTL level |
| | AUDIO OUT | | 200mVrms, output impedance 1kΩ (max. 5.0Vp-p) |
| Speaker output | | | 1W (mono) |
| Power supply | | | AC100~120V/2.7A, AC220~240V/1.5A |
| Power consumption | | | 240W |
| Dimensions | | | 297 (W) × 64 (H) × 233 (D) mm (Not including protruding parts) |
| Weight | | | 2.5kg (5.5lbs) |
| Temperature range | | | Operation : 5~35°C Storage : -20~60°C |
| Accessories | | | Remote control × 1 RGB cable × 1 Power cords × 3 Batteries × 2 Filter cover for bottom up use × 1 Soft case × 1 User's manuals x 1 Video cable x 1 (PJ552/PJ562 only) |

3. Names of each part

● Part names

Projector

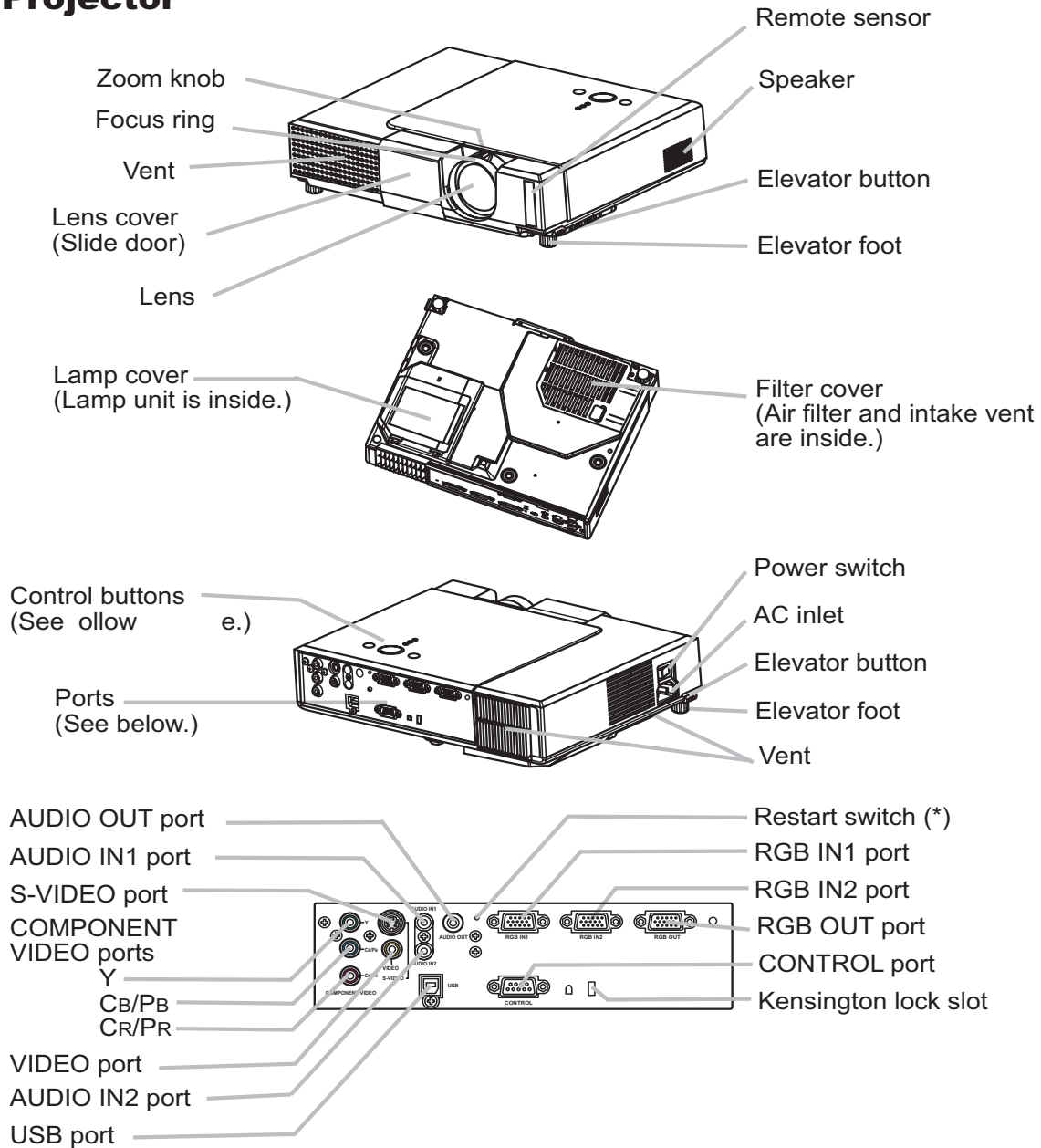

NOTE (*) About Restart switch: This Projector is controlled by an internal microprocessor. Under certain exceptional circumstances, the projector may not operate correctly and the microprocessor will need to be reset. In such a case, please push the Restart switch by using a cocktail stick or similar and before turning on again, make the projector cool down at least 10 minutes without operating. Only push the Restart switch in these exceptional instances.

Control buttons

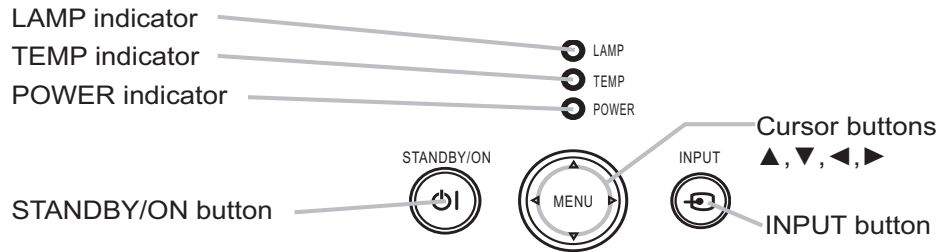

Remote control

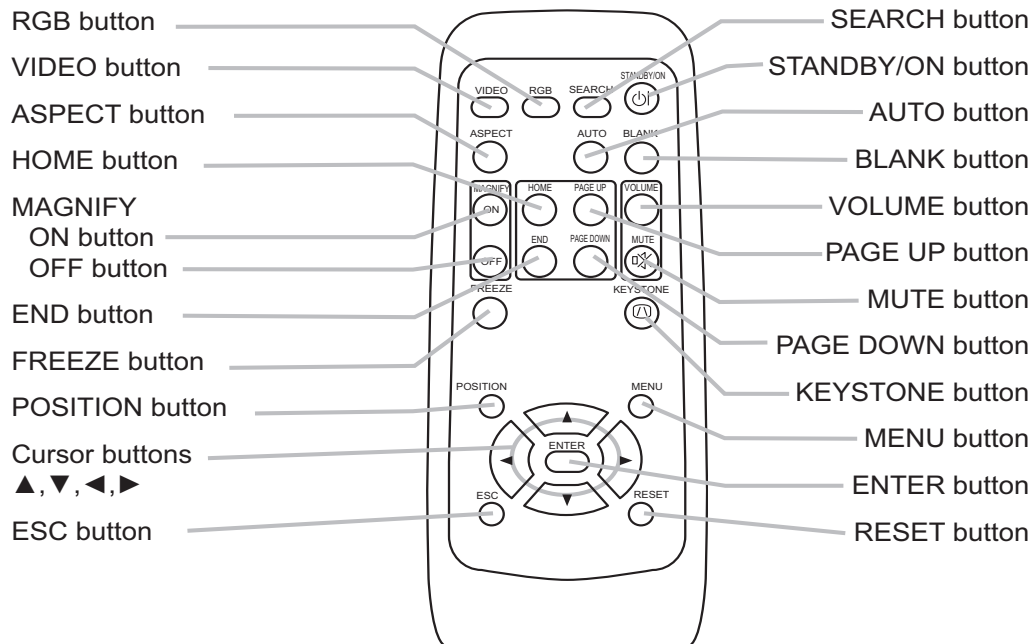

4. Adjustment

4-1 Before adjusting

4-1-1 Selection of adjustment

When any parts in the table 4-1 are changed, choose the proper adjusting items with the chart.

Table 4-1: Relation between the replaced part and adjustment

| Replaced part | Adjustment | | | | | | | |
|-------------------------|---------------------------|---------------------|---------------------|-----------------------|--------------------|--------------------------------|-----------------------------------|---------------------------------|
| | Convergence (Chap.4-2) | E-POS (Chap.4-3) | Ghost (Chap.4-4) | Flicker (Chap.4-5) | NRSB (Chap.4-6) | White balance (Chap.4-7) | Color uniformity (Chap.4-8) | AIR-FLOW- SENS (Chap.4-9) |
| Dichroic optics unit | △ | △ | ○ | ○ | △ | △ | △ | ○ |
| LCD/LENS prism assembly | ○ | ○ | ○ | ○ | ○ | ○ | ○ | △ |
| PWB assembly Main | ○ | ○ | ○ | ○ | ○ | ○ | ○ | ○ |
| Lamp unit assembly | × | × | △ | △ | × | △ | △ | × |

○ : means need for adjustment. × : means not need for adjustment.

△ : means recommended.

4-1-2 Setting of condition before adjustment

1. Before starting adjustment, warm up projector for about 10 minutes.
2. Set Zoom Wide to Max. And project an image with more than 1m (40 inches) in diagonal size.
3. Normalizing the video adjustment
Press the [MENU] button to display the Easy menu. If Advance menu comes up, move to the Easy menu.
Select RESET in the Easy menu and press **[▶]** or [ENTER] button to open the RESET menu window. Choose EXECUTE with **[▲]** button.
Note that no signal input may not allow to reset the adjustments.
4. Select PICTURE > GAMMA in the Advance menu to set to DEFAULT1.
Note that PICTURE menu is not selectable with no signal input displayed.
5. Select PICTURE > COLOR TEMP > CUSTOM in the Advance menu, then press **[▶]** or [ENTER] button to display the equalizing window. Set all the values of OFFSET and GAIN in the window to zero.

Caution: Before this performance, make a note of your customer's adjustments, because the data is overwritten.

6. Perform all adjustments from the FACTORY MENU.

Perform the following operations to display the FACTORY MENU.

< When you use the remote control... >

- a. Press the [MENU] button of remote control to display the Easy menu. (If the Advance menu appears, move to the Easy menu from EASY MENU.)
- b. Select the [RESET] in the Easy menu and then press the **[▶]** or [ENTER] button.
- c. Next, press the [RESET] button one time. And hold the [RESET] button for 3 seconds or more (the FACTORY MENU will appear).

< When you use the keypad... >

- a. Press the **[▲]/[▼]/[◀]/[▶]** button of remote control to display the Easy menu. (If the Advance menu appears, move to the Easy menu from EASY MENU.)
- b. Select the [RESET] in the Easy menu and then press the **[▶]** button.
- c. Next, press the **[▼]** button one time. And repress and hold the **[▼]** button together with the [INPUT] button for 3 seconds or more (the FACTORY MENU will appear).

4-2 Convergence adjustment

Signal pattern for internal adjustment

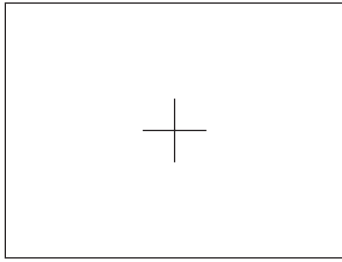

1. Open FACTORY MENU and then select OPTION > CNV-V. Use R and/or B so that three colors of images can be converged at center, top and bottom of the screen.
2. In the same way, select OPTION > CNV-H and use R and/or B so that three colors of images can be converged at center, left and right of the screen.

Adjustment procedure

4-3 E-POS adjustment(vertical bars adjustment)

Signal pattern for internal adjustment

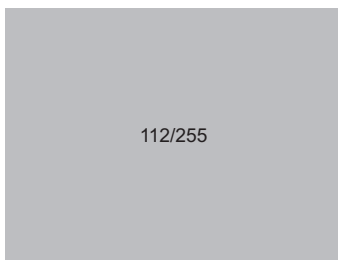

Adjustment procedure

1. Make this adjustment after completing the adjustment 4-2 Convergence adjustment.
2. Choose Advance menu > OPTION > SERVICE > GHOST > R,G and B, and set them to zero.
3. Open FACTORY MENU. Select DAC-P > E-POS > R and use it so that vertical bars can disappear.
4. In the same way, select DAC-P > E-POS > G and use it so that vertical bars can disappear.
5. In the same way, select DAC-P > E-POS > B and use it so that vertical bars disappear.

4-4 Ghost adjustment

Signals for internal adjustment

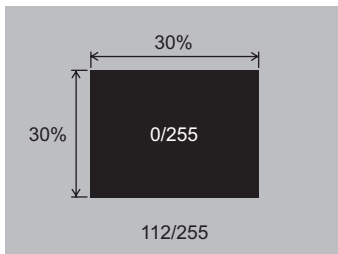

Adjustment procedure

1. Make this adjustment after completing the adjustment in 4-3.
2. Choose Advance menu > OPTION > SERVICE > GHOST > R,G and B, and set them to zero.
3. Use DAC-P - GHOST - R: in the FACTORY MENU to adjust so that R color ghost is at a minimum. (Set the adjustment value to default, and then raise the value. When a ghost appears to the left of a vertical line, reduce the value by 4 steps.)
4. In the same way, use DAC-P - GHOST-G: in the FACTORY MENU to adjust so that G color ghost is at a minimum.
5. In the same way, use DAC-P - GHOST-B: in the FACTORY MENU to adjust so that B color ghost is at a minimum.

4-5 Flicker adjustment (V.COM adjustment)

Signals for internal adjustment

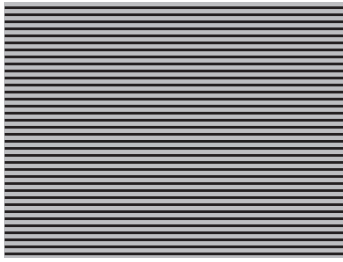

Adjustment procedure

1. Make this adjustment after completing the adjustment in 4-4 Ghost adjustment.
2. Use DAC-P - V.COM - R: in the FACTORY MENU to adjust so that the flicker at the center of the screen is less than the flicker at the periphery. (When the flicker is about the same across the whole screen, adjust so that the flicker at the center of the screen is somewhat less than elsewhere.)
3. In the same way, use DAC-P - V.COM-G: in the FACTORY MENU to adjust the G color flicker.
4. In the same way, use DAC-P - V.COM-B: in the FACTORY MENU to adjust the B color flicker.

4-6 NRSH adjustment (vertical stripe adjustment)

Signals for internal adjustment

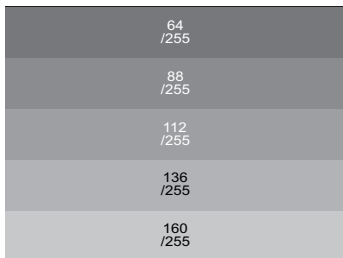

↑ ↓ Press ENTER key

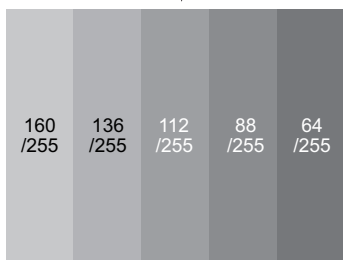

Adjustment procedure

1. Make this adjustment after completing the adjustment in 4-5 Flicker adjustment.
2. Use DAC-P - NRSH - R: in the FACTORY MENU to adjust so that the vertical lines spaced every 6 dots are as inconspicuous as possible. (Reduce the adjustment value when black stripes appear in the 2nd or 3rd tone from the black side. Note that when the adjustment value is lowered, white stripes may appear in the 2nd or 3rd tone from the bright side. Should this happen, adjust so that the stripes are as inconspicuous as possible.)
3. In the same way, use DAC-P - NRSH - G: in the FACTORY MENU to adjust vertical stripes of G color.
4. In the same way, use DAC-P - NRSH - B: in the Adjustment menu to adjust vertical stripes of B color.

4-7 White balance adjustment (visual inspection)

Preparations

1. Perform these adjustments after the NRSH adjustment described in Section 4-6.

Adjustment procedure

1. First, adjust the G color.
2. Select GAMMA, SUB-CNT, and G: in the FACTORY MENU. If the background is white solid, press the [ENTER] key on the Remote control transmitter to change to [G] monochrome in the 33-tone grayscale.
3. Adjust GAMMA, SUB-CNT, and G: in the FACTORY MENU so that brightness of 33 steps is best.
4. Don't adjust GAMMA, SUB-BRT, and G: in the FACTORY MENU. Because we want to keep the best contrast ratio.
5. Then adjust colors R and B.

2. Reset gamma correction before adjustment.
 - Place the cursor on [GAMMA] in the FACTORY MENU, press the [RESET] key and select [DEFAULT].
6. Select GAMMA, SUB-CNT, and G: in the FACTORY MENU. If the background is white solid, press the [ENTER] key on the Remote control transmitter to change to [W] monochrome in the 33-tone grayscale.
7. Adjust GAMMA, SUB-BRT, R: and B: in the FACTORY MENU so that low-brightness white balance is best.
8. Adjust GAMMA, SUB-CNT, R: and B: in the FACTORY MENU so that middle-brightness white balance is best.
9. Repeat steps 7 to 8 above, and adjust so that brightness white balance of 33 steps is best.

4-8 Color uniformity adjustment

Preparations

- Perform these adjustments after the white balance adjustment described in Section 4-7.
- Make a color uniformity adjustment for the following four tones.
 - MIN tone (approx. 4% input signal)
 - MID-L tone (approx. 14% input signal)
 - MID-H tone (approx. 25% input signal)
 - MAX tone (approx. 57% input signal)
- Place the cursor on [C.UNIF.] in the FACTORY MENU and press the **[▶]** key. This displays the Adjust Tone menu at the bottom of the screen. To choose the tone to be adjusted, press the **[▶]** key and then use the **[▲]** or **[▼]** key. Select the major adjustment lattice point No. and color, and then adjust them.
- The major adjustment lattice point numbers (a total of 17 points) corresponds to the major adjustment lattice point positions in the diagram on the right. The color uniformity of the entire screen can be adjusted by adjusting the white balance for each of the points starting in order from the low numbers.
- Adjustment point No.1 should not be adjusted, because it controls the brightness of the entire screen.
- To temporarily turn correction off, place the cursor on [C.UNIF.] in the Adjust Tone menu and press the **[▼]** key. The ON/OFF menu appears. Place the cursor on [ON] with the **[▶]** key and press the **[▼]** key. To turn it on again, place the cursor on [OFF] and press the **[▲]** key.
- Although this adjustment can also be made using internal signals, we will here use the **[ENTER]** key on the Remote control transmitter to select the following two signals.
 - Solid monochrome adjustment color (use G color adjustment when a color differential meter is used).
 - Solid white (use for adjustment other than above).
- Reset color-shading correction before adjustment.
 - When 4 tones and all colors are to be reset, place the cursor on [C.UNIF.] in the FACTORY MENU, press the **[RESET]** key and select **[DEFAULT]**.
 - When only 1 tone is to be reset, place the cursor on the tone to be reset, press the **[RESET]** key and select **[DEFAULT]**.
 - Single tone and monochrome resets cannot be performed.

FACTORY MENU

| |
|----------|
| VID-AD |
| C. UNIF. |
| DAC-P |
| GAMMA |
| STRIPE |
| OPTION |

Adjust tone menu

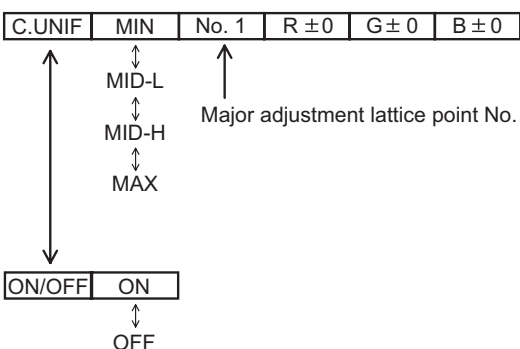

Major adjustment lattice point position

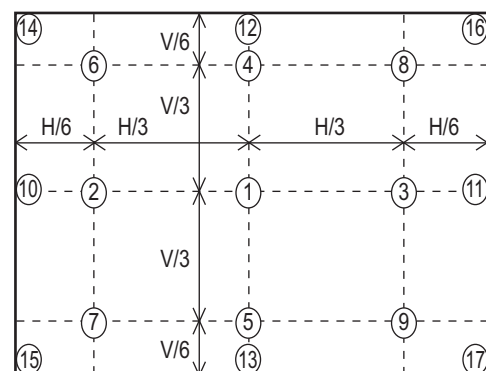

Adjustment procedure 1

(When a color differential meter is used)

1. First adjust [MID-L] tone [G:].
2. Select adjustment point [No.2][G:].
When the background is not [G] monochrome, press the [ENTER] key on the Remote control transmitter to change to solid [G] monochrome.
3. Measure the illumination at adjustment points No. 2, No.3, No.10 and No.11.
The values should be:
No.2 = Y2 [lx] No.10 = Y10 [lx]
No.3 = Y3 [lx] No.11 = Y11 [lx]
4. No.2 and No.3 adjustment point have the average of Y2 and Y3.
 $Y2 = (Y2 + Y3) / 2 \pm 2 [\%]$
 $Y3 = (Y2 + Y3) / 2 \pm 2 [\%]$
5. No.10 and No.11 adjustment point have the average of Y10 and Y11.
 $Y10 = (Y10 + Y11) / 2 \pm 2 [\%]$
 $Y11 = (Y10 + Y11) / 2 \pm 2 [\%]$
6. Then adjust [MID-L] tone [R] and [B].
When the background is [G] monochrome, press the [ENTER] key on the Remote control transmitter to change to solid white.
7. Measure the color coordinates of adjustment point [No.1] and make a note of them.
Assume that they are $x = x1$, $y = y1$.
Note: When the CL-100 color and color difference meter is used, the $[\Delta]$ (delta) mode is convenient. When adjustment point [No.1] color coordinate has been selected, set the slide switch on the side to $[\Delta]$ (delta) while holding down the [F] button on the front panel. The measurement shown after this displays the deviation from measurement point 1.
8. Measure the color coordinates of measurement point [No.2] and adjust [No.2][R:] and [B:] so that the coordinates are as follows.
 $x = x1 \pm 0.005$, $y = y1 \pm 0.010$
9. Similarly, measure adjustment points [No.3] to [No.17] and adjust their color coordinates starting in order from the small number points.
This completes adjustments required for [MIN].
Note: Since excessive correction may lead to a correction data overview during internal calculations, use the following values for reference.
[No.2] to [No.5] ± 40 or less
[No.6] to [No.9] ± 50 or less
[No.10] to [No.13] ± 70 or less
[No.14] to [No.17] ± 120 or less
10. Then adjust [MIN] tone [G] so that the adjustment data set two times as much as [MID-L] tone [G].
This completes [G] color adjustments.
11. Then adjust [MIN] tone [R] and [B].
Select [No.2] [B:] and press the [ENTER] key on the Remote control transmitter to change to solid white.
12. Measure the color coordinates of adjustment point [No.1] and make a note of them.
Assume that they are $x = x1$, $y = y1$.
13. Now measure the color coordinates of measurement point [No.2] and adjust [No.2][R:] and [B:] so that the coordinates are as follows.
 $x = x1 \pm 0.005$, $y = y1 \pm 0.010$ (Target)
 $x = x1 \pm 0.020$, $y = y1 \pm 0.040$
14. Similarly, measure adjustment points [No.3] to [No.17] and adjust their color coordinates starting in order from the small number points.
This completes [MIN] tone adjustments.
15. Now make similar adjustments for [MID-H] tone.
(Adjust [MID-H] tone [G] so that the adjustment data set half as many as [MID-L] tone [G].)
16. Now make similar adjustments for [MAX] tone.
(Adjust [MAX] tone [G] so that the adjustment data set half as many as [MID-L] tone [G].)

Adjustment procedure 2

(visual inspection)

1. First adjust [MIN] tone [G:].
2. Select [No.2] [G:].
If the background is [G] monochrome, press the [ENTER] key on the Remote control transmitter to change to solid white.
3. View measurement point [No.2] and [No.3].
Lower the [G] color intensity only of the color point whose [G] color is more intense than measurement point [No.1].
4. View measurement point [No.10] and [No.11].
Lower the [G] color intensity only of the color point whose [G] color is more intense than measurement point [No.1] and raise the intensity of the point whose color intensity is lower than measurement point [No.1].
5. Now adjust the [MIN] tone for colors [R] and [B].

6. View measurement points [No.2], [No.3], [No.10] and [No.11]. Adjust the [R] and [B] of each measurement point so that they have the same color as measurement point [No.1].

Adjustment technique:

First, adjust [B:] of the point whose color is to be adjusted so that it approximates that of [No.1]. If [R:] is low at this time, the image will have cyan cast, in which case [R:] is increased. On the other hand, if [R:] is excessive, the image will have a magenta cast, in which case [R:] is decreased.

Overall, a cyan cast makes it easy to see color shading.

7. Next, view measurement points [No.4], [No.5], [No.12], [No.13] and make similar adjustments.
8. Then adjust measurement points [No.6], [No.7], [No.8], [No.9], [No.14], [No.15], [No.16] and [No.17]. This completes the [MIN] tone adjustments.
9. Make similar another three tones as described in steps 1 to 8 above.

No. 2 deviation range

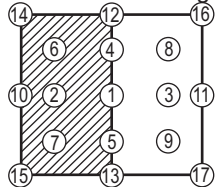

No. 10 deviation range

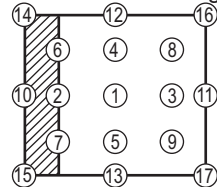

No. 3 deviation range

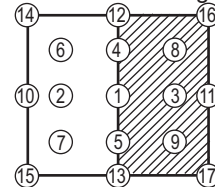

No. 11 deviation range

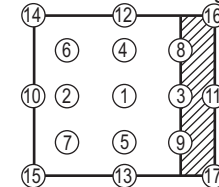

No. 4 deviation range

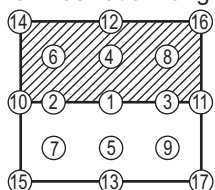

No. 12 deviation range

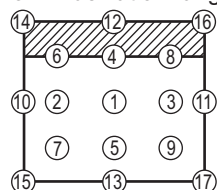

No. 5 deviation range

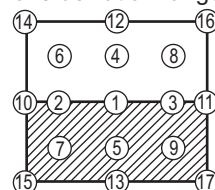

No. 13 deviation range

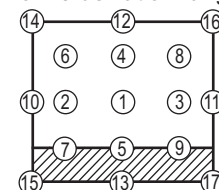

No. 6 deviation range

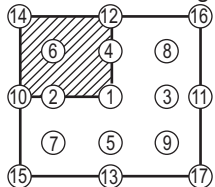

No. 7 deviation range

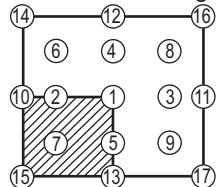

No. 8 deviation range

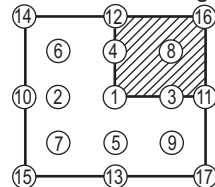

No. 9 deviation range

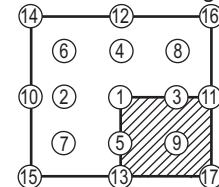

No. 14 deviation range

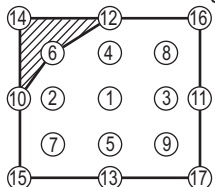

No. 15 deviation range

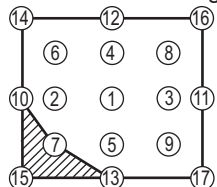

No. 16 deviation range

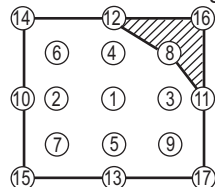

No. 17 deviation range

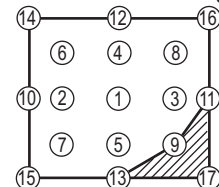

4-9 AIR-FLOW-SENS adjustment

When the PWB assembly MAIN is replaced, perform this adjustment after completing reassembling the projector.

1. Set the item "WHISPER" to "NORMAL", then warm up for 5 minutes or more.
2. Open HIDDEN SERVICE MENU with the following procedure and choose "AIR-FLOW-SENS" by using [▼] button.

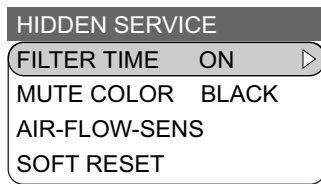

How to open HIDDEN SERVICE menu

| By the control panel | By the remote control transmitter |
|--|---|
| <ol style="list-style-type: none"> 1. Display the Advance menu by the "MENU" button. (If EASY MENU appears, choose "Go to Advance menu" to display ADVANCE MENU.) 2. Select the "OPTION" on the menu. 3. Continue press the button [◀] first, then press the button [◀] together with "INPUT" and hold for 3 seconds. | <ol style="list-style-type: none"> 1. Display the Advance menu by the "MENU" button. (If EASY MENU appears, choose "Go to Advance menu" to display ADVANCE MENU.) 2. Select the "OPTION" on the menu. 3. Press the "MAGNIFY OFF" button. Next hold the "MAGNIFY OFF" button for 3 seconds. |

3. Pressing the [▶] button displays the adjustment window. Use the [▲] button to select EXECUTE. The automatic adjustment program runs.
4. After the message of "END" is displayed in the window, read the given offset value and make sure that it is in the range; $120 \leq \text{offset} \leq 170$.

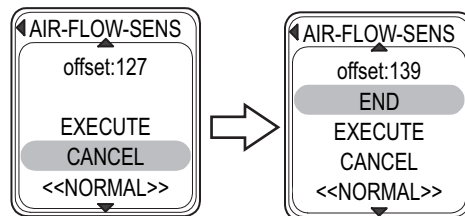

5. Next, select <<NORMAL>> using [▼] button. Pressing [◀] / [▶] button changes to <<WHISPER>>. Wait for 30 seconds or more before following operations.
6. Perform the same operations as the steps 2 and 3 above.
7. After the message of "END" is displayed, read the given offset value and make sure that it is in the range; $90 \leq \text{Offset} \leq 150$
8. If both or either of offset values are out of the specified ranges, make sure the below conditions. Then retry the same adjustments.
 - 1) The air filter is not choke up with dust.
 - 2) No lose connection of connector E301 and E302.
9. If the adjustments failed after treatment, replace either of next parts.
 - 1) PWB assembly MAIN
 - 2) DC FAN (panel)
 - 3) Thermal sensor (inside)

5. Troubleshooting

Check points

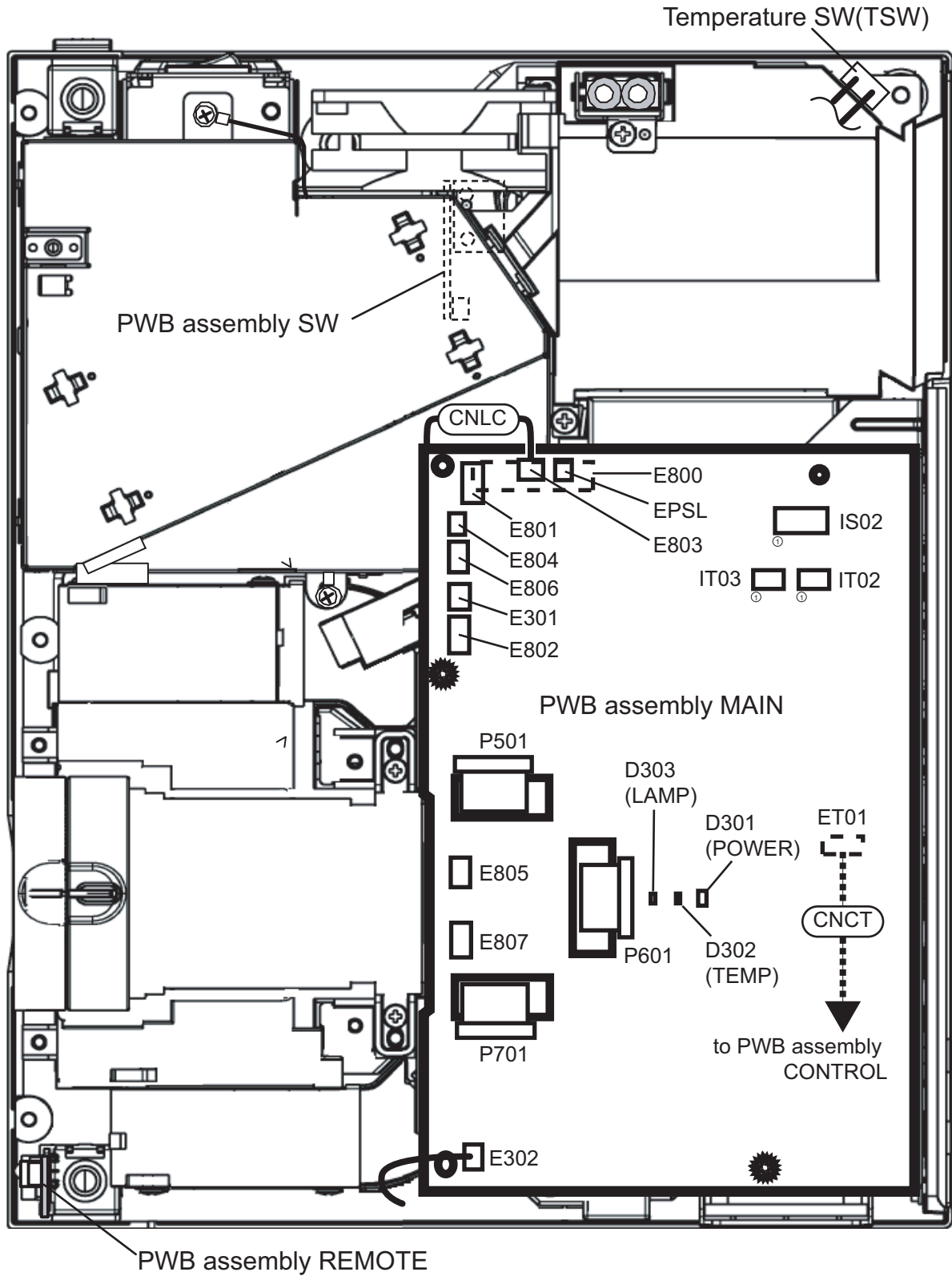

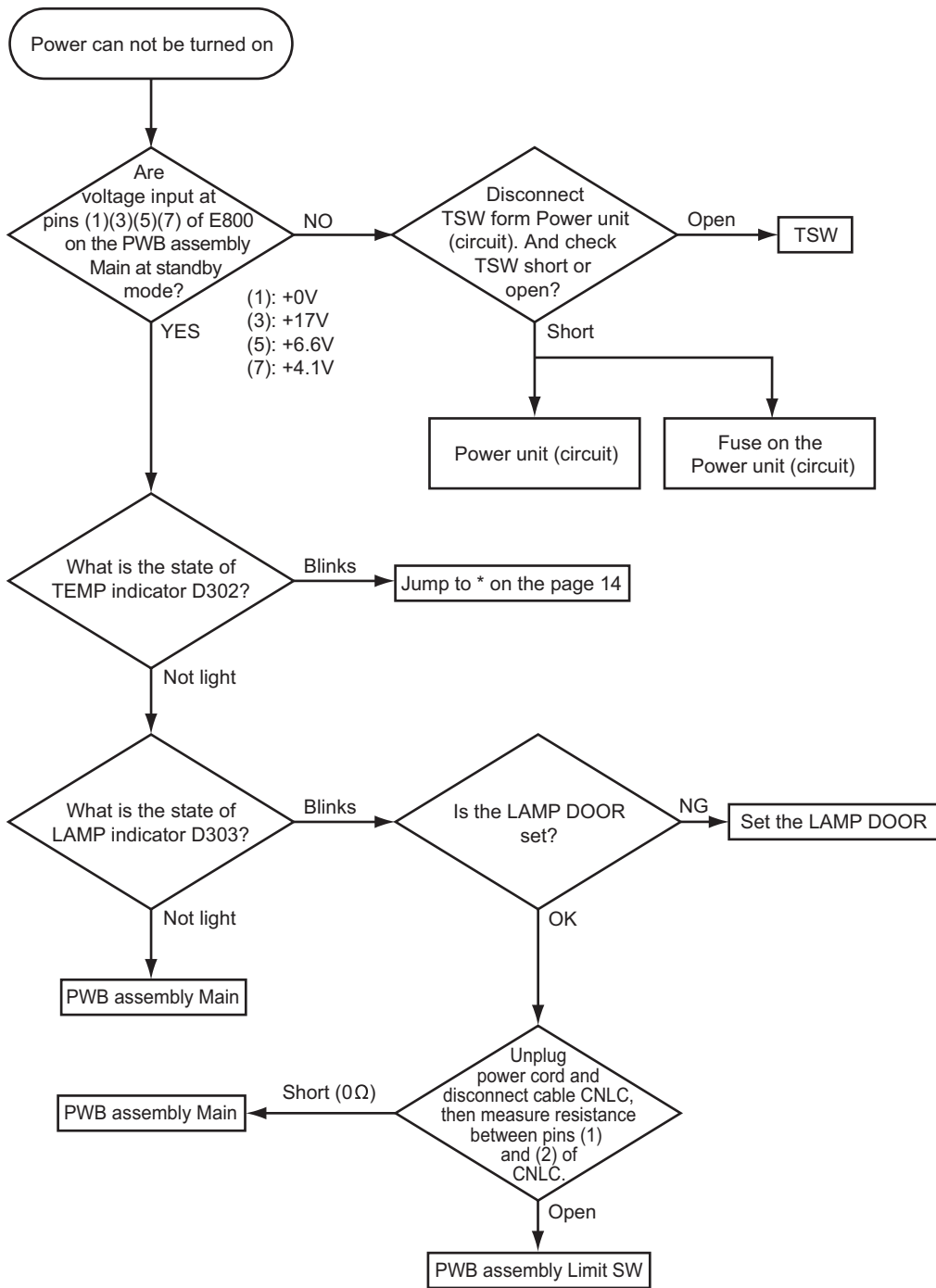

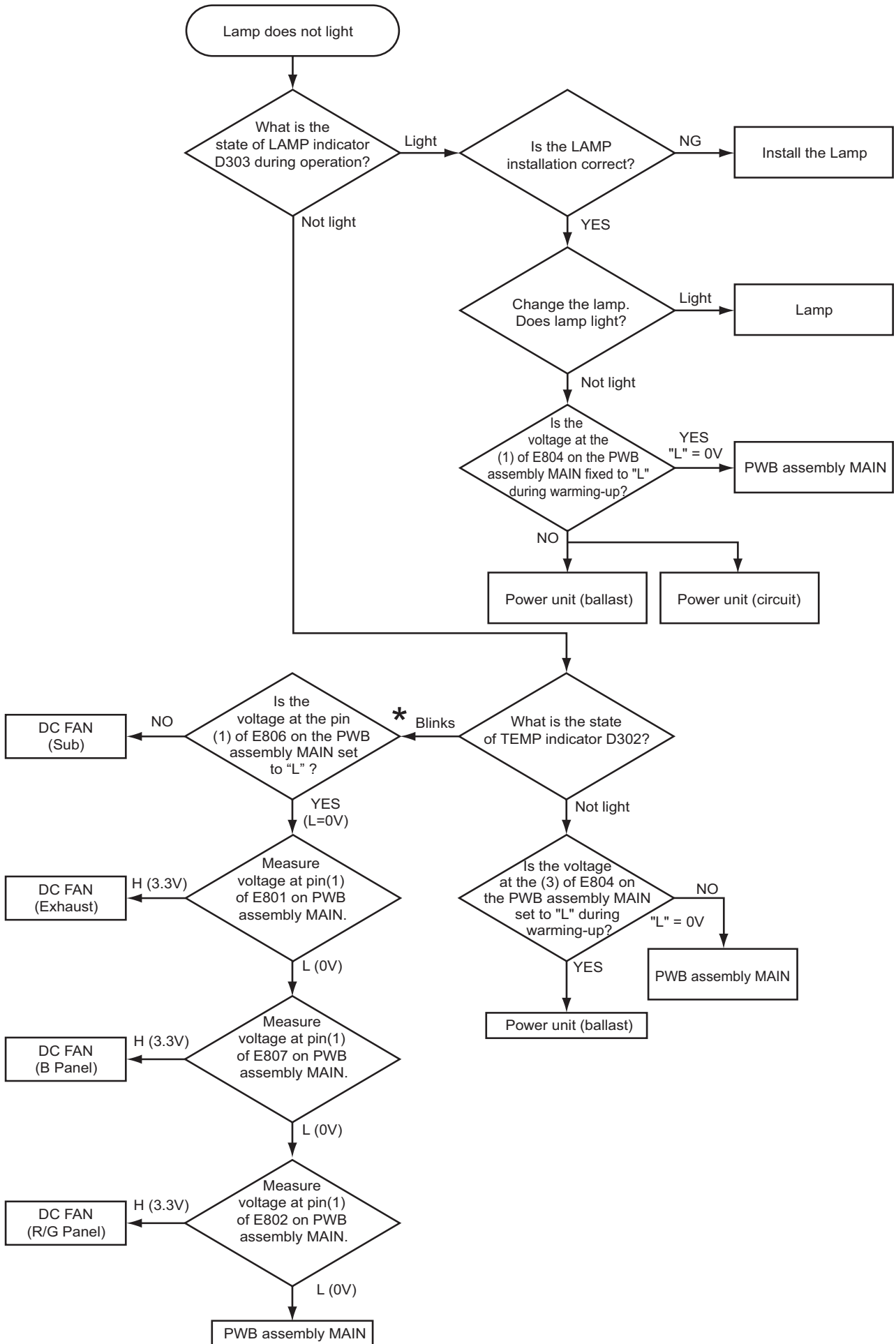

CP-S335(C9SM)/CP-X340, PJ552 (C9X)/CP-X345, PJ562 (C9XM)

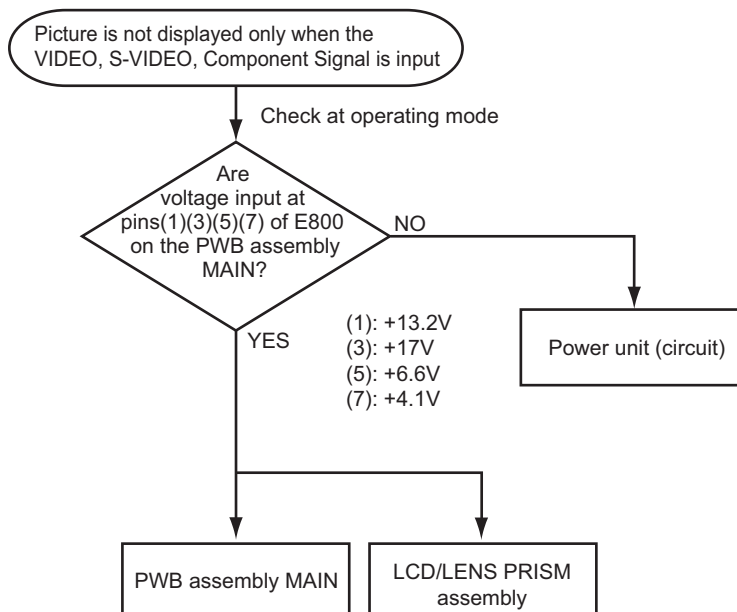
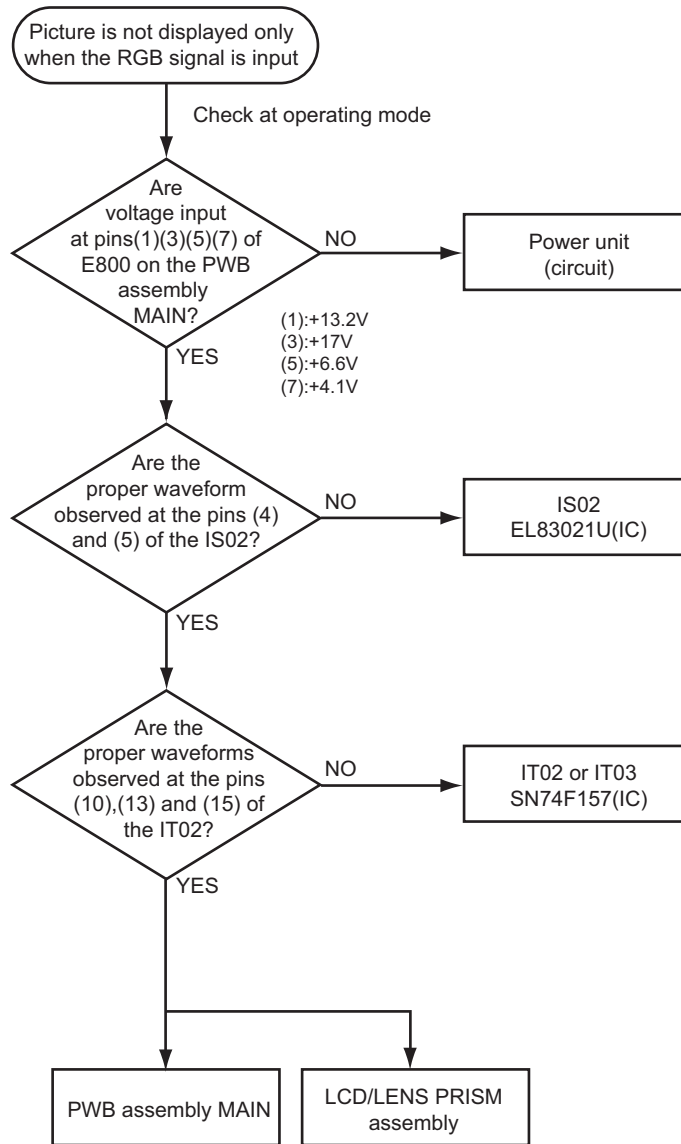

CP-S335(C9SM)/CP-X340, PJ552 (C9X)/CP-X345, PJ562 (C9XM)

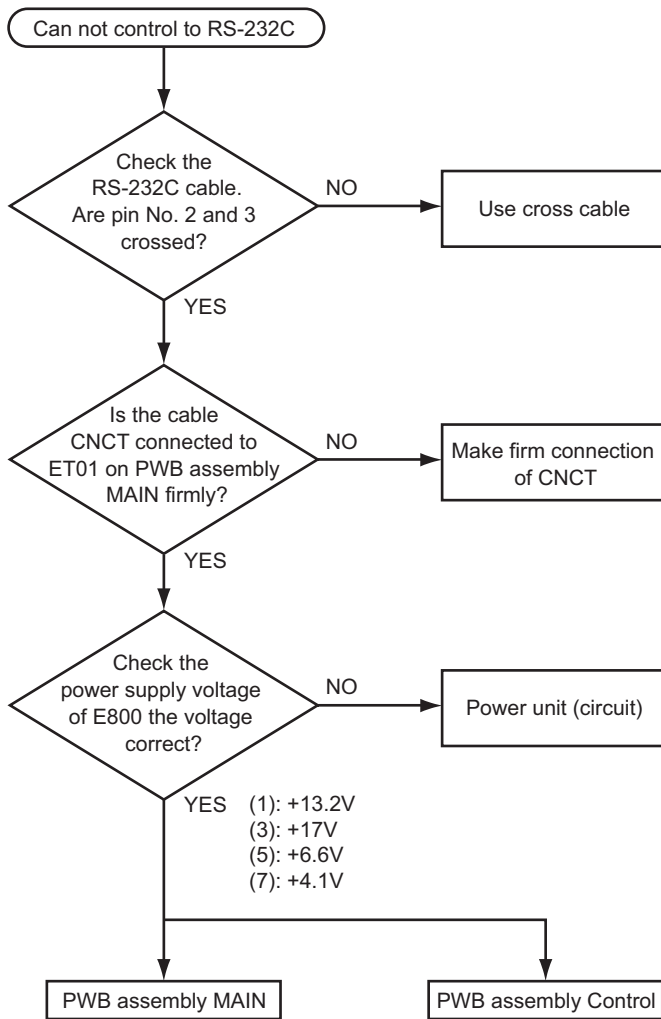

The check after parts change

1. PC power supply OFF
 2. Connection of cable
 3. Projector starting
 4. PC starting
- *When not operating :
PC set up change of cable.

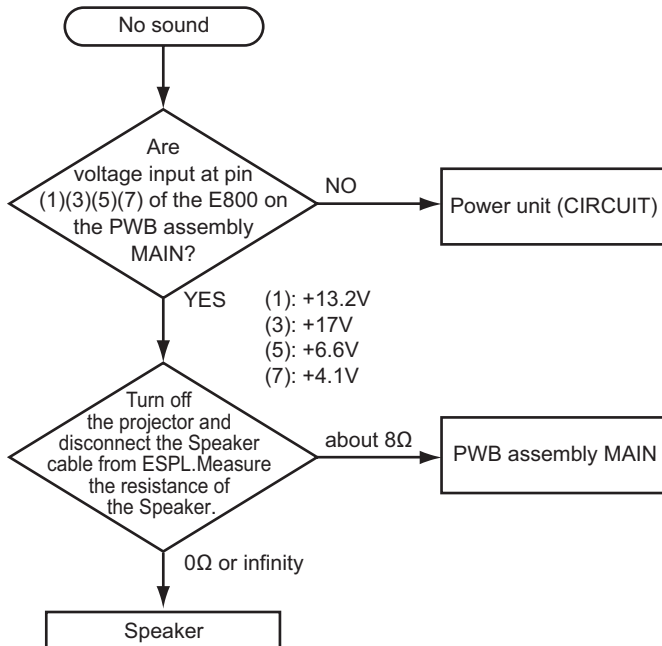

6. Service points

6-1 Lead free solder [CAUTION]

This product uses lead free solder (unleaded) to help preserve the environment. Please read these instructions before attempting any soldering work.

⚠ CAUTION

Always wear safety glasses to prevent fumes or molten solder from getting into the eyes. Lead free solder can splatter at high temperatures (600°C).

■ Lead free solder indicator

Printed circuit boards using lead free solder are engraved with an "F" or "LF".

■ Properties of lead free solder

The melting point of lead free solder is 40-50°C higher than leaded solder.

■ Servicing solder

Solder with an alloy composition of Sn-3.0Ag-0.5Cu or Sn-0.7Cu is recommended.

Although servicing with leaded solder is possible, there are a few precautions that have to be taken. (Not taking these precautions may cause the solder to not harden properly, and lead to consequent malfunctions.)

Precautions when using leaded solder

- Remove all lead free solder from soldered joints when replacing components.
- If leaded solder should be added to existing lead free joints, mix in the leaded solder thoroughly after the lead free solder has been completely melted (do not apply the soldering iron without solder).

■ Servicing soldering iron

A soldering iron with a temperature setting capability (temperature control function) is recommended.

The melting point of lead free solder is higher than leaded solder. Use a soldering iron that maintains a high stable temperature (large heat capacity) and that allows temperature adjustment according to the part being serviced, to avoid poor servicing performance.

Recommended soldering iron:

- Soldering iron with temperature control function (temperature range: 320-450°C)

Recommended temperature range per part:

| Part | Soldering iron temperature |
|---------------------------------|----------------------------|
| Mounting (chips) on mounted PCB | 320°C±30°C |
| Mounting (chips) on empty PCB | 380°C±30°C |
| Chassis, metallic shield, etc. | 420°C±30°C |

The PWB assembly which has used lead free solder

- | | |
|--------------------------|--------------------------|
| (1) PWB assembly MAIN | (4) PWB assembly SW |
| (2) PWB assembly CONTROL | (5) POWER UNIT (BALLAST) |
| (3) PWB assembly REMC | (6) POWER UNIT (CIRCUIT) |

6-2 Before Replacing The LCD/Lens Prism

You should not replace separately the parts of the liquid crystal LCD/Lens prism because it works properly only when used together. Therefore, regarding these parts, you can either replace part, LCD/Lens prism assembly, or send the whole unit LCD/Lens prism assembly back to HITACHI, where we will replace the malfunctioning part, recondition the device and send it back to you.

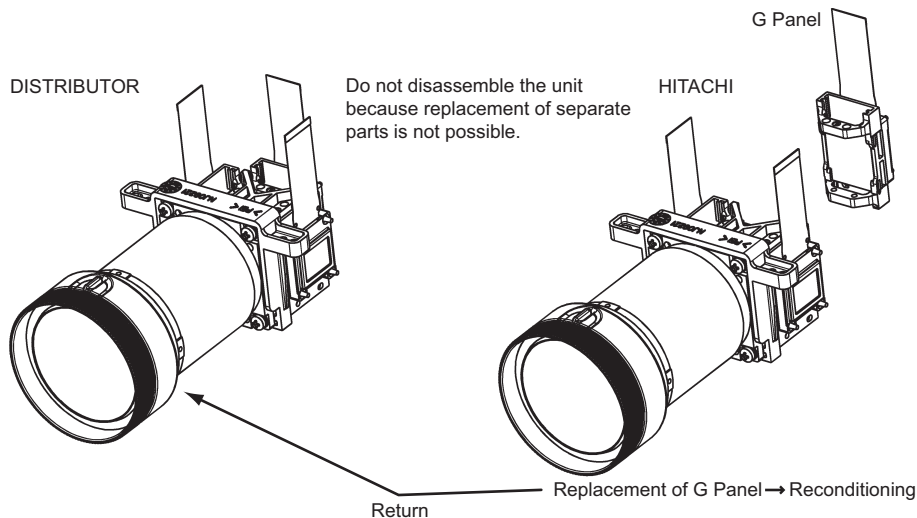

6-3 Cleaning up dust from panels and optical filters

1. Preparation

Please prepare cleaning tools and materials as follows. And prepare relatively clean room not to work in additional dust, while removing operation.

- (1) Swab for cleaning : P#: NX08061, "Cotton stick L147"
- (2) Air duster (Dust blower, spray can)
- (3) Vacuum cleaner

2. Disassemble and open the maintenance hole.

- (1) Turn off the projector, and unplug the power cord.
- (2) Remove the top cover, according to the disassembling diagram of chapter 8.
- (3) Remove the PWB assembly MAIN, according to the Notice-5 of the Chapter 8.
- (4) Remove the Panel Cover.

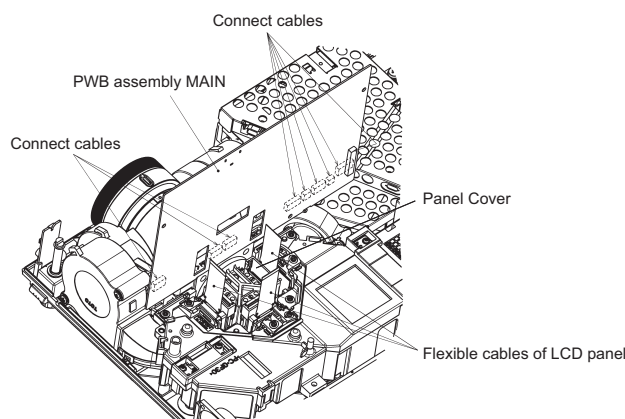

- (5) Re-assemble the PWB assembly MAIN, and re-connect toward projection lens. Then place the board vertically shown above so that LCD panels can be seen. Note that connectors for LCD panels should be empty.

3. Maintenance point

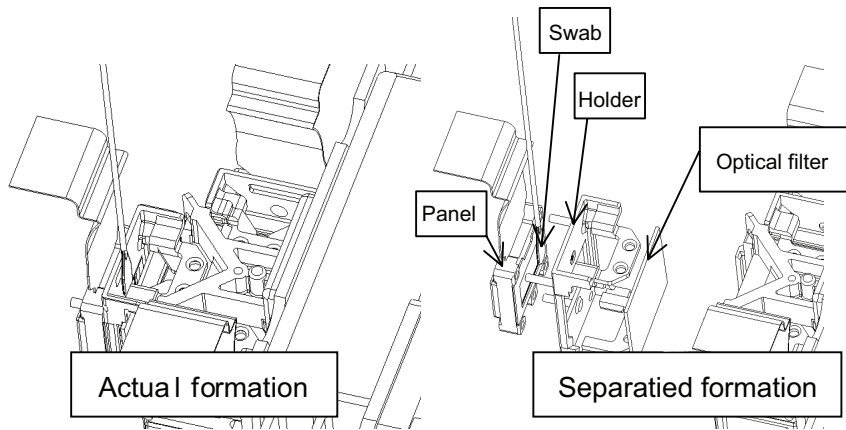

Each color part has same construction.
By using swab and air duster, you can easily remove dust from panel and optical filter.

4. Cleaning the panels and optical filters

- (1) Turn on the set and lit on the lamp.
- (2) Set blank screen to white.
- (3) By using swab and air duster, remove the dust. Focusing dust makes you check the dust on screen.

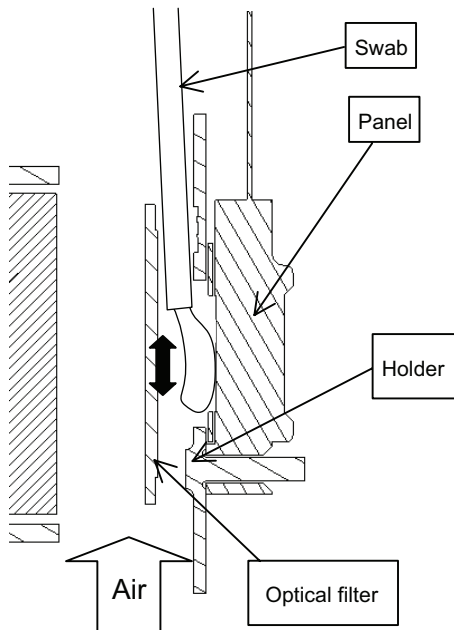

- While removing the dust, separated dust will be blown off by air cooling system.
- Please pay attention not to damage panel and filter.

5. Re-assembly

- (1) Turn off the set and remove the PWB assembly MAIN.
- (2) Set the Panel cover.
- (3) Re-assemble the PWB assembly MAIN.
- (4) Re-assemble the set.
- (5) While re-assembling, please clean the Panel cover and intake filter and filter cover by using vacuum cleaner.

6-4 Putting batteries

WARNING

Always handle the batteries with care and use them only as directed. Improper use may result in battery explosion, cracking or leakage, which could result in fire, injury and/or pollution of the surrounding environment.

- Be sure to use only the batteries specified. Do not use batteries of different types at the same time. Do not mix a new battery with used one.
- Make sure the plus and minus terminals are correctly aligned when loading a battery.
- Keep a battery away from children and pets.
- Do not recharge, short circuit, solder or disassemble a battery.
- Do not allow a battery in a fire or water. Keep batteries in a dark, cool and dry place.
- If you observe a leakage of a battery, wipe out the flower and then replace a battery. If the flower adheres your body or clothes, rinse well with water immediately.

1. Remove the battery cover.

Slide back and remove the battery cover in the direction of the arrow.

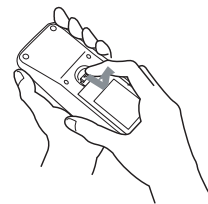

2. Insert the batteries.

Align and insert the two AA batteries according to their plus and minus terminals as indicated in the remote control.

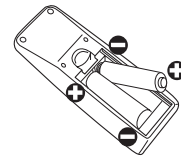

3. Close the battery cover.

Replace the battery cover in the direction of the arrow and snap it back into place.

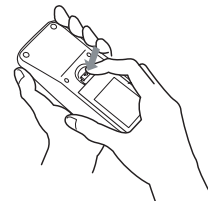

6-5 Air filter

! WARNING

- Before caring, make sure the power switch is off and the power cable is not plugged in, and then allow the projector to cool sufficiently. The care in a high temperature state of the projector could cause a burn and/or malfunction to the projector.
- Use only the air filter of the specified type. Do not use the projector with the air filter and filter cover removed.
- Avoid wetting the projector or inserting liquids in the projector. It could result in a fire, an electric shock, and and/or malfunction to the projector.

! CAUTION

- Please replace the air filter when it is damaged or too soiled, and also when you replace the lamp.





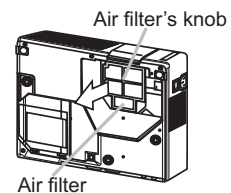
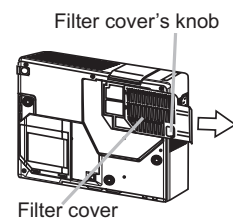

When the indicators or a message prompts you to clean the air filter, clean the air filter as soon as possible. If the air filter becomes clogged by dust or the like, internal temperatures rise and the power may be automatically turned off for malfunction prevention.

1. Turn the projector off, and unplug the power cord. Allow the projector to cool for at least 45 minutes. And prepare a vacuum cleaner.
2. After making sure that the projector is cool adequately, slowly turn the projector so that the lens-side is facing up. Please be careful for a projector not to fall. While the projector is placed lens-side up, hold the projector.
3. Putting a finger on the filter cover's knob, slide the filter cover in the direction of the arrow to remove it.
4. Holding the air filter's knob, pull the air filter off.
5. Apply a vacuum cleaner to the vent of the projector for the air filter. And then slowly turn the projector bottom up.
6. Apply a vacuum cleaner to the air filter and filter cover.
Please replace the air filter when it is damaged or too soiled.
 Use only the air filter of the specified type: **NJ09702**.
 An air filter of specified type will come even with the replacement lamp for this projector.
7. Position the cleaned air filter or a new air filter into place, and push the points of "PUSH" word with claws to fix the air filter.
8. Replace the filter cover and snap it back into place.
9. Slowly turn the projector so that the top is facing up.
10. Turn the projector on, and reset the filter time.
 - (1) While projector running, press the MENU button of remote control or the [▲]/[▼]/[◀]/[▶] button of keypad to open menu.
 - (2) Choose FILTER TIME in EASY menu or in OPTION of Advance menu.
 - (3) Press and hold RESET button of the remote control or [▶] button of the keypad for 3 seconds. FILTER TIME reset window will appear.
 - (4) Choose RESET using [▲] button.



NOTE • Incorrectly resetting of the filter timer (resetting without replacement, or neglect of resetting after replacement) will result in incorrect message functions.

6-6 Lamp

| | | | |
|--|--|---|--|
|  WARNING |  HIGH VOLTAGE |  HIGH TEMPERATURE |  HIGH PRESSURE |
| <p>• The projector uses a high-pressure mercury glass lamp. The lamp can <u>break with a loud bang, or burn out</u>, if jolted or scratched, handled while hot, or worn over time. Note that each lamp has a different life-time, and some may burst or burn out soon after you start using them. In addition, when the bulb bursts, it is possible for <u>shards of glass</u> to fly into the lamp housing, and for <u>gas containing mercury</u> to escape from the projector's vent holes.</p> | | | |
| <p>• About disposal of a lamp • This product contains a mercury lamp; do not put in trash. Dispose of in accord with environmental laws. For lamp recycling, go to www.lamprecycle.org. (in the US) For product disposal, contact your local government agency or www.eiae.org (in the US) or www.epsc.ca (in Canada).</p> | | | |
|  Disconnect the plug from the power outlet | <ul style="list-style-type: none"> • If the lamp should break (it will make a loud bang when it does), unplug the power cord from the outlet. Note that shards of glass could damage the projector's internals, or cause injury during handling. • If the lamp should break (it will make a loud bang when it does), ventilate the room well, and make sure not to breathe the gas that comes out of the projector vents, or get it in your eyes or mouth. • Before replacing the lamp, turn the projector off and unplug the power cord, then wait at least 45 minutes for the lamp to cool sufficiently. Handling the lamp while hot can cause burns, as well as damaging the lamp. | | |
|  | <ul style="list-style-type: none"> • Never unscrew except the appointed (marked by an arrow) screws. • Do not open the lamp cover while the projector is suspended from above. This is dangerous, since if the lamp's bulb has broken, the shards will fall out when the cover is opened. • Do not use the projector with the lamp cover removed. At the lamp replacing, make sure that the screws are screwed in firmly. Loose screws could result in damage or injury. | | |
|  | <ul style="list-style-type: none"> • Use only the lamp of the specified type. • If the lamp breaks soon after the first time it is used, it is possible that there are electrical problems elsewhere besides the lamp. • Handle with care: jolting or scratching could cause the lamp bulb to burst during use. • If the indicators or a message prompts you to replace the lamp (see the section "Related Messages" and "Regarding the indicator Lamps"), replace the lamp as soon as possible. Using the lamp for long periods of time, or past the replacement date, could cause it to burst. Do not use old (used) lamps; this is a cause of breakage. | | |

● Replacing the Lamp

When the indicators or a message prompts you to replace the lamp, replace the lamp as soon as possible.

1. Turn the projector off, and unplug the power cord. Allow the lamp to cool for at least 45 minutes.
 2. Prepare a new lamp. The lamp type number is DT00671.
 3. After making sure that the projector has cooled adequately, slowly turn over the projector, so that the bottom is facing up.
 4. Please unhook the claws of the lamp cover using a minus screwdriver or similar, and remove the lamp cover.
 5. Loosen the 2 screws (marked by arrow) of the lamp, and slowly pick up the lamp by the handles.
 6. Insert the new lamp, and retighten firmly two screws that are loosened in the previous process to lock it in place.
 7. Interlocking the 2 tabs of the lamp cover to the projector, position the lamp cover on the projector. Then push the center point of two claws to fix the lamp cover.
 8. Slowly turn the projector so that the top is facing up.
7. Turn the projector on, and reset the lamp time.
- (1) Select the item of LAMP TIME in OPTION of Advance menu
 - (2) Press and hold RESET button of the remote control or [▶] button of the keypad for 3 seconds. LAMP TIME reset window will appear.
 - (3) Choose RESET using [▲] button.

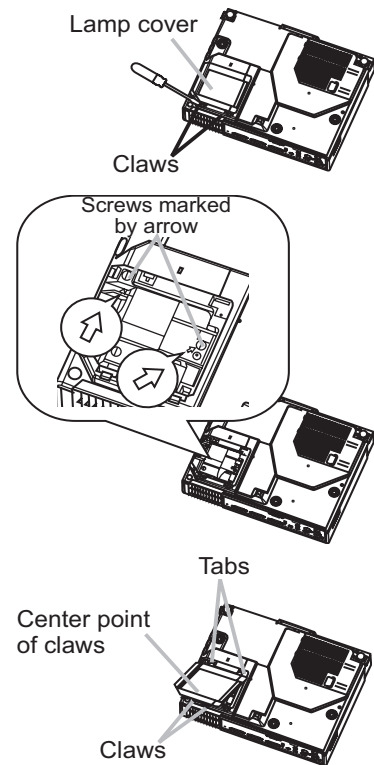

NOTE • When the lamp has been replaced after the message of “THE POWER WILL TURN OFF AFTER 0hr .” is displayed, complete the following operation within 10 minutes of switching power on. Incorrectly resetting of the lamp timer (resetting without replacement, or neglect of resetting after replacement) will result in incorrect message functions.

6-7 Other care

WARNING

Before caring, make sure the power switch is off and the power cable is not plugged in, and then allow the projector to cool sufficiently. The care in a high temperature state of the projector could cause a burn and/or malfunction to the projector.

Avoid wetting the projector or inserting liquids in the projector. It could result in a fire, an electric shock, and and/or malfunction to the projector.

- Don't put a container containing water, cleaner or chemicals near the projector.
- Don't use aerosols or sprays.

CAUTION

Please take right care of the projector according to the following. Incorrect care could cause not only an injury but adverse influence such as discoloration, peeling paint, etc.

- Do not use cleaner or chemicals other than those listed below.
- Do not polish or wipe with hard objects.

● Inside of the projector

In order to ensure the safe use of the projector, it needs to clean and inspect the projector about once every 2 years.

● Caring for the lens

If the lens is flawed, soiled or fogged, it could cause deterioration of display quality. Please take care of the lens, being cautions of the handling.

1. Turn the projector off, and unplug the power cord. Allow the projector to cool sufficiently.
2. After making sure that the projector is cool adequately, lightly wipe the lens with a commercially available lens-cleaning wipe. Do not touch the lens directly with your hand.

● Caring for the cabinet and remote control

Incorrect care could have adverse influence such as discoloration, peeling paint, etc.

1. Turn the projector off, and unplug the power cord. Allow the projector to cool sufficiently.
2. After making sure that the projector is cool adequately, lightly wipe with gauze or a soft cloth.

If soiling is severe, dip soft cloth in water or a neutral cleaner dilute in water, and wipe lightly after wringing well. Then, wipe lightly with a soft, dry cloth.

6-8 Notice of AUTO adjustment

Use of AUTO adjustment with the image through RGB input optimizes V_POSI, H_POSI, H_SIZE and H_PHASE automatically.

In case that projected image has dark tone around its peripheral, AUTO operation sometimes makes artifacts in the image, shifts capture area and so on. Those failures are caused by period of image data is not exactly distinguished to period of blanking on signal processing.

To avoid such phenomena, AUTO function should be used with the full size picture that has bright tone on its peripheral.



Image when AUTO operates correctly

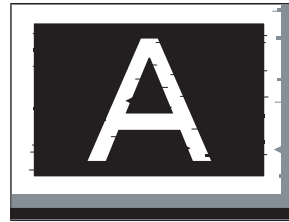

Image when AUTO fails.

- Noting image of top or bottom lines.
- Shift of the image to East or West.
- Artifacts on image. Etc.

Note

- 1) The phenomenon at the failure of AUTO adjustment depends on resolution of input source, scene of picture etc.
- 2) There is no failure above in AUTO with video source through VIDEO, S-VIDEO or COMPONENT input. The reason is why recognition of input signal's standard does not need to search the capture range from input signal itself.

6-9 PIN LOCK System (not PJ552, PJ562 models)

If the following PIN BOX menu appears after power on the projector, the PIN LOCK system has been activated. Under such a condition, key operations and signal displaying are inhibited. To open the PIN LOCK system, we need to input the correct 4 digits PIN CODE. If correct PIN CODE is not input in 5 min., the lamp will be automatically turned off.



PIN BOX

Returning repaired unit

Use the Master PIN code. See the paragraph of Releasing the PIN LOCK system inactivation.

Swap unit/Returned unit

Inactivate the PIN LOCK system. See the paragraph of the PIN LOCK system inactivation.

Releasing the PIN LOCK System

When the PIN BOX menu is displayed, sequentially enter the codes with remote controller as follows. In accordance with remote controller button entry, “*” mark appears in the PIN BOX menu.

Master PIN codes

- 1st entry code: Press the “MENU” button.
- 2nd entry code: Press the “▼” button.
- 3rd entry code: Press the “KEYSTONE” button.
- 4th entry code: Press the “▲” button.

Note: The Master PIN codes can be used up to 30 times. The codes cannot be used thereafter. If the Master PIN codes cannot be used, see the paragraph of the PIN LOCK system inactivation.

The PIN LOCK System inactivation

1. When the PIN BOX menu is displayed, press “RESET” for 3 seconds or more in order to get the ID Inquiring Code.

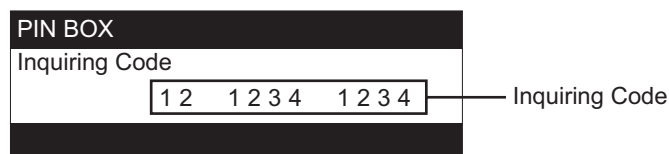

PIN BOX (ID Inquiring Code)

2. Send HITACHI sales company the Inquiring code (10 digits) to inquire the correct PIN code.
 3. With the PIN BOX menu displayed, input the correct PIN code. Enter the correct PIN CODE that HITACHI sales company informed.
 4. Open menu and select “TURN OFF” from the PIN LOCK items in the OPTION menu. Then the PIN BOX menu appears.
 5. Input the correct PIN code in the PIN BOX menu.
 6. And then, the OPTION menu appears.
- After the PIN LOCK system is inactivated, the PIN BOX is no longer displayed in the OPTION menu. If the PIN LOCK items are kept displaying, the PIN LOCK system is not inactivated yet. Input the correct PIN CODE again.

6-10 Related Messages

When the unit's power is on, messages such as those shown below may be displayed. When any such message is displayed on the screen, please respond as described below.

Although these messages will automatically disappear after a few minutes, they will reappear every time the power is turned on.

| Message | Description |
|---|--|
| CHANGE THE LAMP AFTER REPLACING LAMP, RESET THE LAMP TIMER. | The time the lamp timer has counted is approaching 2000 hours. Preparation of a new lamp and an early lamp change is recommended. After you have change the lamp, please be sure to reset the lamp timer . |
| CHANGE THE LAMP AFTER REPLACING LAMP, RESET THE LAMP TIMER. THE POWER WILL TURN OFF AFTER ** hr. | The time the lamp timer has counted is approaching 2000 hours, so a lamp change within ** hours is recommended. When lamp usage reaches 2000 hours, the power will automatically be turned off. Please change the lamp by referring to the section "Lamp". After you have changed the lamp, please be sure to reset the lamp timer. |
| CHANGE THE LAMP AFTER REPLACING LAMP, RESET THE LAMP TIMER. THE POWER WILL TURN OFF AFTER 0 hr. | As the time the lamp timer has counted has reached 2000 hours, the power will soon be automatically turned off. Please immediately turn the power off and change the lamp by referring to the section "Lamp". After changing the lamp, please be sure to reset the lamp timer. |
| NO INPUT IS DETECTED ON *** | There is no input signal. Please confirm the signal input connection and the status of the signal source. |
| SYNC IS OUT OF RANGE ON *** [H] *****kHz [V] *****Hz | The horizontal or vertical wavelength of the inputted signal is outside of the response parameters of this unit. Please confirm the specs for this unit or the signal source specs. |
| CHECK THE AIR FLOW | The internal portion temperature is rising. Please turn the power OFF and allow the unit to cool down at least 20 minutes. After having confirmed the following items, please turn the power ON again. <ul style="list-style-type: none"> • Is there blockage of the air passage aperture? • Is the air filter dirty? • Does the peripheral temperature exceed 35°C? • If the same indication is shown after checking, please set to HIGH at FAN SPEED of the item SERVICE in the OPTION menu. |
| CLEAN THE AIR FILTER POWER OFF FIRST, THEN CLEAN THE AIR FILTER. AFTER CLEANING THE AIR FILTER, RESET THE FILTER TIMER. | A note of precaution when cleaning the air filter. Please immediately turn the power OFF and clean or change the air filter by referring to the "Air Filter" section of this manual. After you have cleaned or changed the air filter, please be sure to reset the filter timer. |

PJ552(C9X)/PJ562(C9XM)

| Message | Description |
|---|--|
| To maximize performance, lamp replacement is recommended. | After the lamp running reaches 2000 hours, the warning message is displayed, but it won't shut the unit off. The message displays for 30 seconds when the PJ is turned on. If we push any button while displaying the message, the message disappears. |
| CLEAN THE AIR FILTER POWER OFF FIRST, THEN CLEAN THE AIR FILTER. AFTER CLEANING THE AIR FILTER, RESET THE FILTER TIMER. | The time the filter timer has counted has reached 100 hours. Please clean or change the air filter by referring to the section "Air filter". After caring for the air filter, please be sure to reset the filter timer. |
| NO INPUT IS DETECTED ON *** | There is no input signal. Please confirm the signal input connection and the status of the signal source. |
| SYNC IS OUT OF RANGE ON *** [H] *****kHz [V] *****Hz | The horizontal or vertical wavelength of the inputted signal is outside of the response parameters of this unit. Please confirm the specs for this unit or the signal source specs. |
| CHECK THE AIR FLOW | The internal portion temperature is rising. Please turn the power OFF and allow the unit to cool down at least 20 minutes. After having confirmed the following items, please turn the power ON again. <ul style="list-style-type: none"> • Is there blockage of the air passage aperture? • Is the air filter dirty? • Does the peripheral temperature exceed 35°C? • If the same indication is shown after checking, please set to HIGH at FAN SPEED of the item SERVICE in the OPTION menu. |
| CLEAN THE AIR FILTER POWER OFF FIRST, THEN CLEAN THE AIR FILTER. AFTER CLEANING THE AIR FILTER, RESET THE FILTER TIMER. | A note of precaution when cleaning the air filter. Please immediately turn the power OFF and clean or change the air filter by referring to the "Air Filter" section of this manual. After you have cleaned or changed the air filter, please be sure to reset the filter timer. |

NOTE • A lamp has a finite product life. Lamps are characterized by the fact that, after long hours of usage, a lamp will no longer light up, or the lamp will break or burst, etc. This projector is equipped with an automatic shut-down function, such that the power will automatically be turned off when lamp usage time has reached 2000 hours. Please be aware, however, that among lamp types, there are major differences in product lifetimes. A lamp may thus fail to light even prior to the functioning of the automatic shut-down function of this projector.

6-11 Regarding the indicator lamps

Lighting and flashing of the POWER indicator, the LAMP indicator, and the TEMP indicator have the meanings as described in the table below. Please respond in accordance with the instructions with in the table.

| POWER indicator | LAMP indicator | TEMP indicator | Description |
|------------------------------------|------------------------------|-----------------|---|
| Lighting In Orange | Turned off | Turned off | The projector is in a standby state. |
| Blinking In Green | Turned off | Turned off | The projector is warming up. Please wait. |
| Lighting In Green | Turned off | Turned off | The projector is in an on state. Ordinary operations may be performed. |
| Blinking In Orange | Turned off | Turned off | The projector is cooling down. Please wait. |
| Blinking In Red | (discretionary) | (discretionary) | The projector is cooling down. A certain error has been detected. Please wait until the POWER indicator finishes blink, and then perform the proper response measure using the item descriptions below as reference. |
| Blinking In Red or Lighting In Red | Blinking In Red | Turned off | Either there is no lamp cover, or it has not been properly fixed. Please turn the power off, and allow the unit to cool down at least 45 minutes. After the projector has sufficiently cooled down, please make confirmation of the attachment state of the lamp cover, and then turn the power on again. |
| Blinking In Red or Lighting In Red | Lighting In Red | Turned off | The projector lamp has not been properly fixed(attached), the lamp does not light, and there is a possibility that interior portion has become heated. Please turn the power off, and allow the unit to cool down at least 20 minutes. After the projector has sufficiently cooled down, please make confirmation of the following items, and then turn the power on again. <ul style="list-style-type: none"> • Is there blockage of the air passage aperture? • Is the air filter dirty? • Does the peripheral temperature exceed 35°C? If the same indication is displayed after the treatment, please change the lamp by referring to the section "Lamp". |
| Blinking In Red or Lighting In Red | Turned off | Blinking In Red | The cooling fan is not operating. Please turn the power off, and allow the unit to cool down at least 20 minutes. After the projector has sufficiently cooled down, please make confirmation that no foreign matter has become caught in the fan, etc. and then turn the power on again. If the same indication is displayed after the treatment, please change a fan. |
| Blinking In Red or Lighting In Red | Turned off | Lighting In Red | There is a possibility that the interior portion has become heated. Please turn the power off, and allow the unit to cool down at least 20 minutes. After the projector has sufficiently cooled down, please make confirmation of the following items, and then turn the power on again. <ul style="list-style-type: none"> • Is there blockage of the air passage aperture? • Is the air filter dirty? • Does the peripheral temperature exceed 35°C? If the same indication is displayed after the treatment, please set the HIGH at the FAN SPEED of the item SERVICE of the OPTION menu. |
| Lighting In Green | Alternative blinking in Red | | There is a possibility that the interior portion has become overcooled. Please use the unit within the usage temperature parameters (5°C to 35°C). After the treatment, resent the power to ON. If the same indication is displayed after the treatment, please make sure the wire connection of the connectors E301 and E302 on the PWB assembly MAIN. |
| Lighting In Green | Simultaneous blinking in Red | | It is time to clean the air filter. Filter timer has counted 100hours or more. Please immediately turn the power OFF, and clean or change the air filter by referring to the section "Air Filter". After cleaning or changed the air filter, please be sure to reset the filter timer. After the treatment, resent the power to ON. |

NOTE • When the interior portion has become overheated, for safety purposes, the power source is automatically turned off, and the indicator lamps may also be turned off. In such a case, press the "○" (OFF) side of the power switch, and wait at least 45 minutes. After the projector has sufficiently cooled down, please make confirmation of the attachment state of the lamp and lamp cover, and then turn the power on again.

6-12 HIDDEN SERVICE MENU

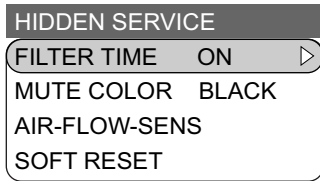

To display the OSD for "HIDDEN SERVICE MENU" set up.

| By the control panel | By the remote control transmitter |
|---|---|
| <ol style="list-style-type: none"> 1. Display the Advance menu by the "MENU" button.(If EASY MENU appears, choose "Go to Advance menu" to display ADVANCE MENU.) 2. Select the "OPTION" on the menu. 3. Continue press the button [◀] first, then press the button [◀] together with "INPUT" and hold for 3 seconds. | <ol style="list-style-type: none"> 1. Display the menu by the "MENU" button. (If EASY MENU appears, choose "Go to Advance menu" to display ADVANCE MENU.) 2. Select the "OPTION" on the menu. 3. Press the "MAGNIFY OFF" button. Next hold the "MAGNIFY OFF" button for 3 seconds. |

● Setup of Filter time ("ON" or "OFF")

1. Select the "FILTER TIME" on the OSD using button [▼].

Next press the [▶] to select "FILTER TIME MENU" by the HIDDEN SERVICE MENU.

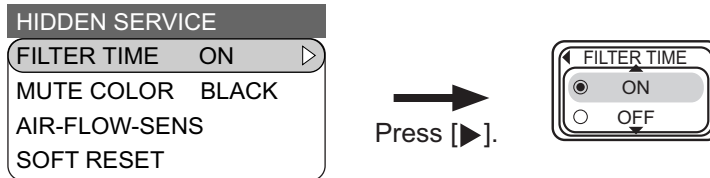

2. ON : Select the "ON" on the OSD using button [▲].

OFF : Select the "OFF" on the OSD using button [▼].

3. The OSD will be ended by no operation for 10 seconds or change of input signal. To end immediately, use one of buttons except buttons [▲],[▼],[◀],[▶].

6-13 RUN TIME window

● Set operating time display method (accumulated lamp time display method)

1. Select "OPTION" from the Advance menu, then place the cursor on the "LAMP TIME".
2. Press the [Reset] button once, then press [KEYSTONE] button of the remote control for 3 seconds or more to display the screen shown below. (The menu will close after 10 seconds if there are no further operations.)
3. Use [▲] or [▼] to select the usage status number. (The usage status is as shown below.)

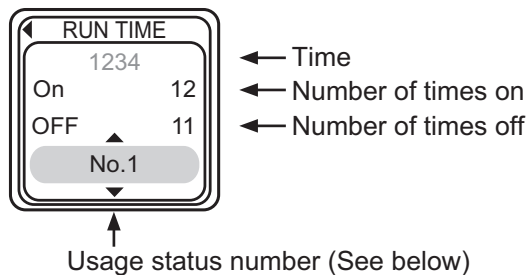

Usage status number

- 0 Total usage status
- 1 Current usage status
- 2 Usage status before first reset
- 3 Usage status before second reset
- ||
- 9 Usage status before eighth reset

Wiring the circuit power source/ballast power source boards, and the control main board (When assembling board sub-assembly)

Wiring circuit power source board

- (1) Connect TSW .
- (2) Connect CNPOW.
- (3) Connect CNPWR, and install FEB1.

Confirm that CN102 and CN103 are securely connected.
(This cannot be confirmed downstream.)

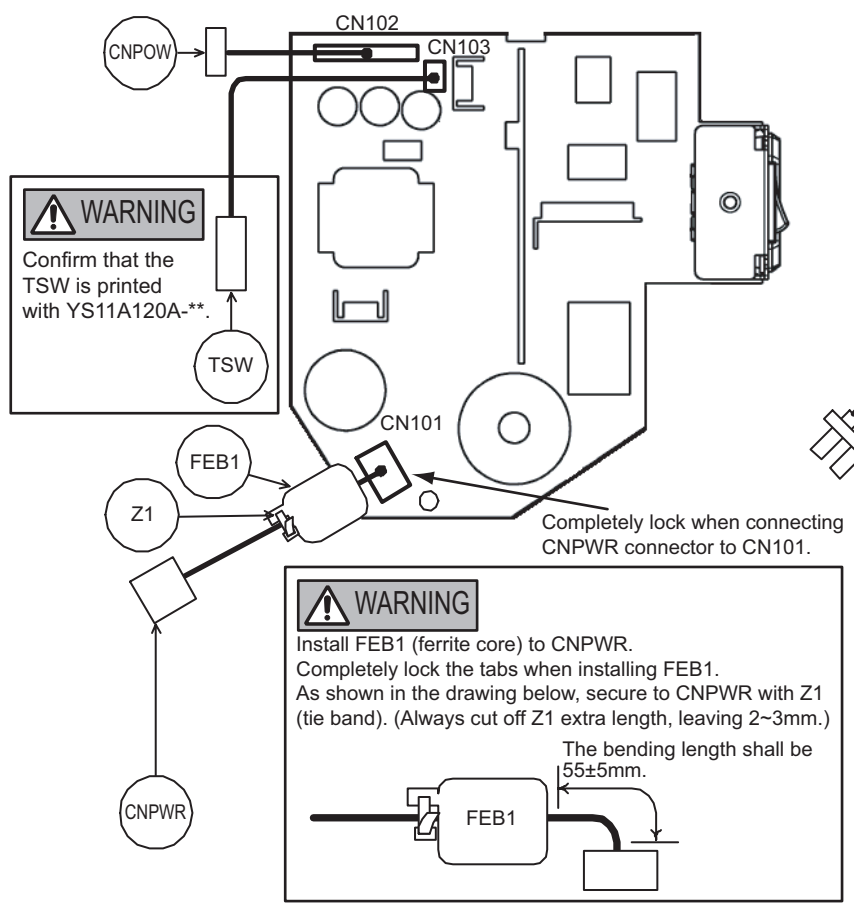

Wiring ballast power source board

- (1) Connect CNBAR.
- (2) Install FEB2.
- (3) Wire CNBAR and #6800.

- * The FEB2 style shall be as shown below.
- * Orient the FEB2 protrusion inward.
- * Keep the lamp lead extra length to a minimum.

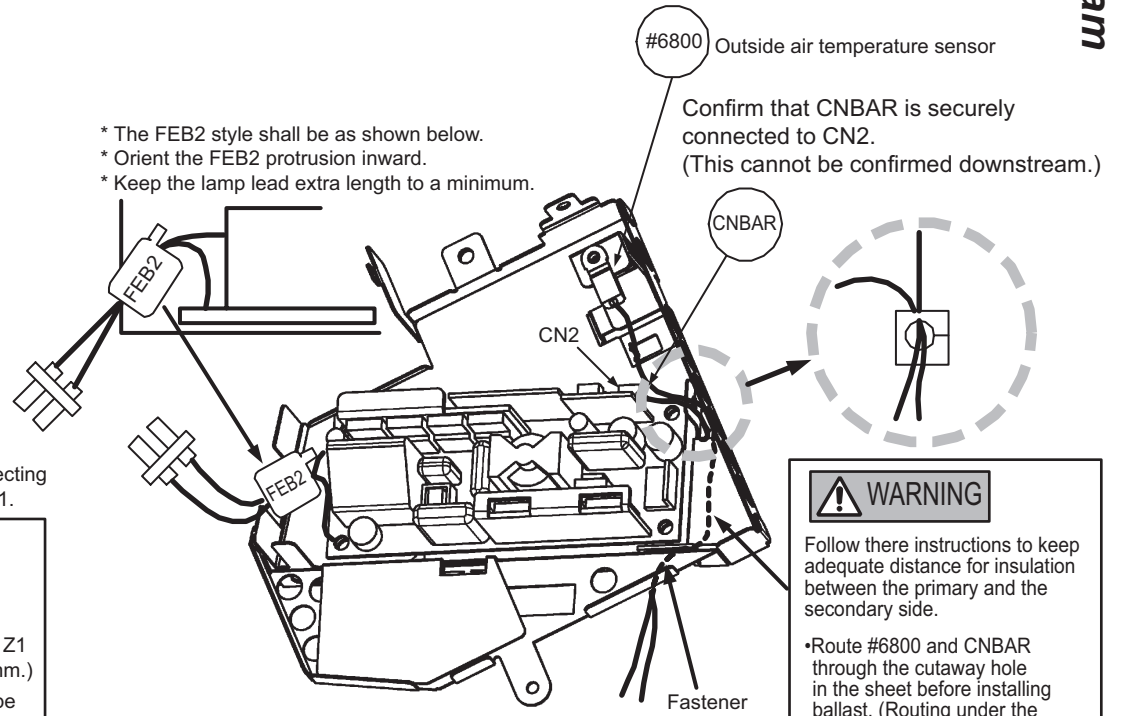

WARNING
Instructions in this chapter are based on the standards and/or the laws. Deviation from instructions could be against the standards and/or the laws. Always put together according to these instructions.

WARNING
Follow these instructions to keep adequate distance for insulation between the primary and the secondary side.

- Route #6800 and CNBAR through the cutaway hole in the sheet before installing ballast. (Routing under the sheet is difficult after installing the ballast power source.)
- Lay #6800 and CNBAR to eliminate sag.
- Route #6800 and CNBAR between the sheet and case, through the fastener, and lock them.

Wiring diagram 1 (C9SM/C9X/C9XM)

Wiring power supply unit (When assembling board block sub-assembly) Wiring when assembling control panel

Wiring when assembling power supply unit

- (1) Wire CNPOW and TSW.
- (2) Connect and wire CNPWR.
- (3) Connect and wire lamp leads, CD2, and CNSH

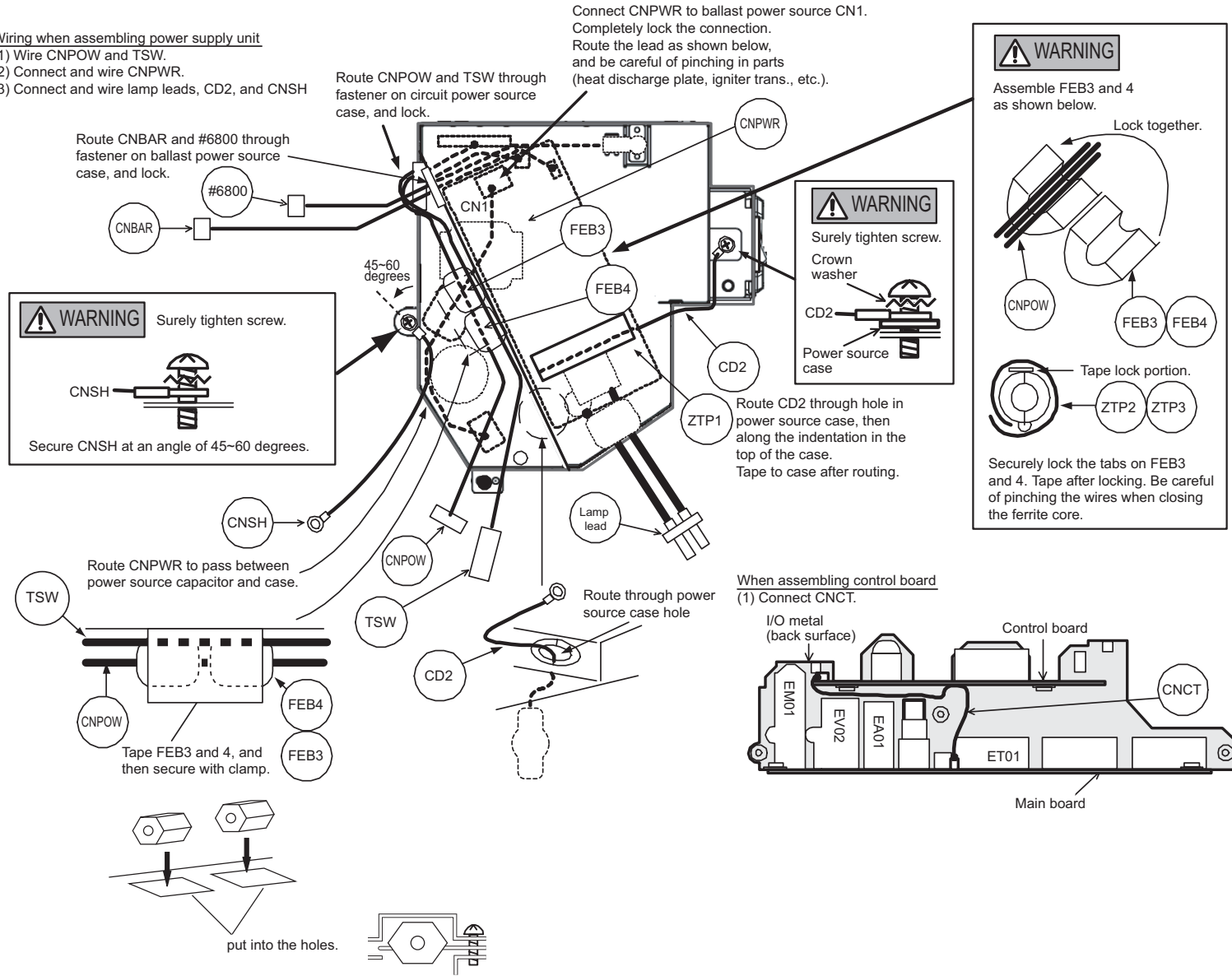

Wiring diagram 2 (C9SM/C9X/C9XM)

Wiring during bottom case assembly and optical engine assembly

When assembling bottom case

- (1) Install and wire A83 (speaker).
- (2) Wire CNLC (from limit switch board).

Be careful not to pinch wires when installing optical engine.

When assembling optical engine

- (1) Assemble remote control board, and connect CNRM.
- (2) Wire #3055 (axial flow fan).

Secure CNLC and #3055 by inserting into bottom case slit. Insert wires into slit nearer to optical engine. (Wire CNLC before installing optical engine, and be careful of pinching wires when installing the optics engine.)

Connect CNRM first when assembling remote control board.

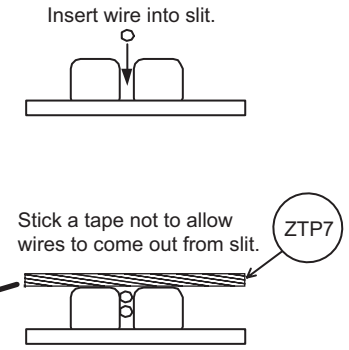
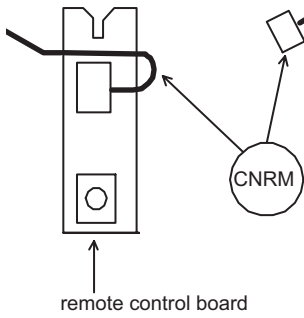

Tape A83 leads after inserting into slit. (To prevent coming out from slit.)

Route #3055 lead on the hook of optical engine, being careful that the wire does not sag toward the limit switch.

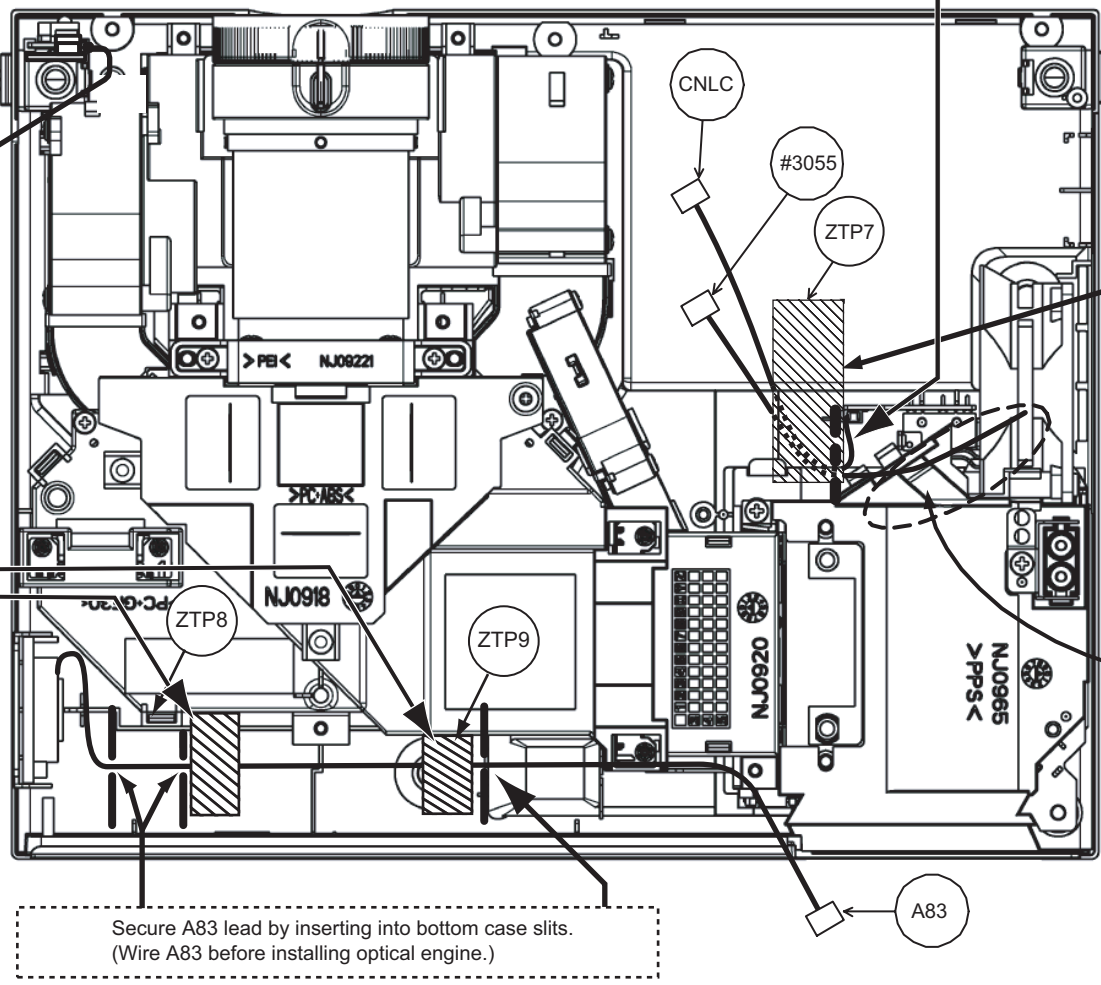

Secure A83 lead by inserting into bottom case slits. (Wire A83 before installing optical engine.)

Wiring diagram 3 (C9SM/C9X/C9XM)

Wiring when assembling power source

When assembling power source

- (1) Caution: Avoid pinching wires when installing power source.
(CNLC, #3055, #6607, TSW, CNPOW)
- (2) Connect lamp leads.

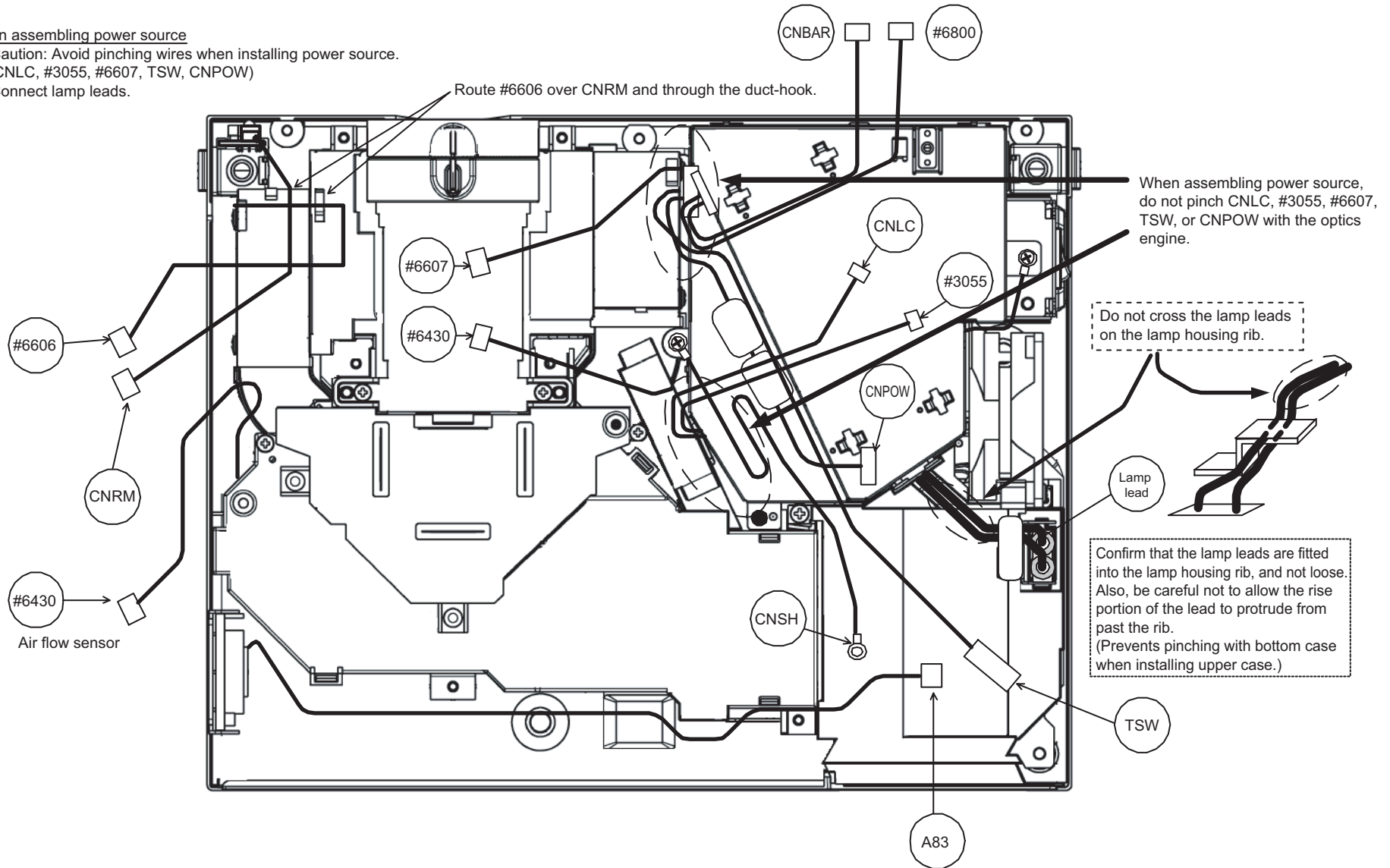

Wiring diagram 4 (C9SM/C9X/C9XM)

Wiring when mounting main board

When mounting main board

- (1) Place the LCD panel flexible cable coming out of the board hole when assembling the main board.
- (2) Connect CNPOW. (Note: On back surface of main board)
- (3) Connect #6430 (air flow sensor), #6606, CNRM, #6607, #6430, #6800, CNBAR, #3055, CNLC, and A83. (Do not connect CNSH yet.)
- (4) Connect flexible cable for LCD panel.

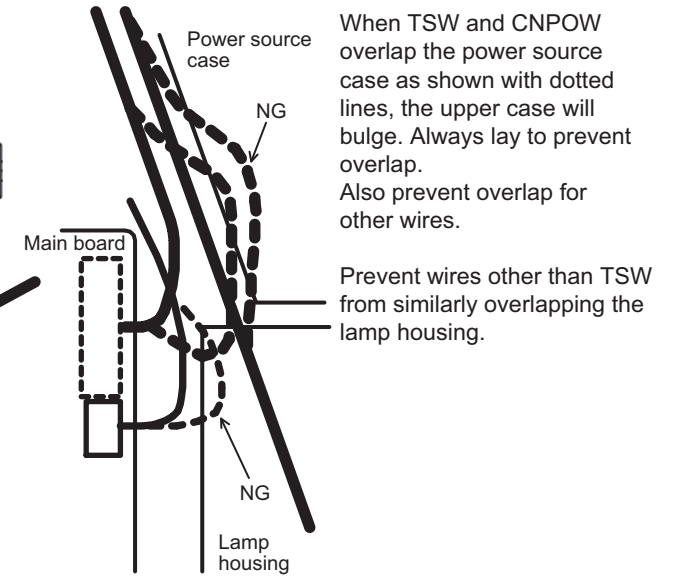
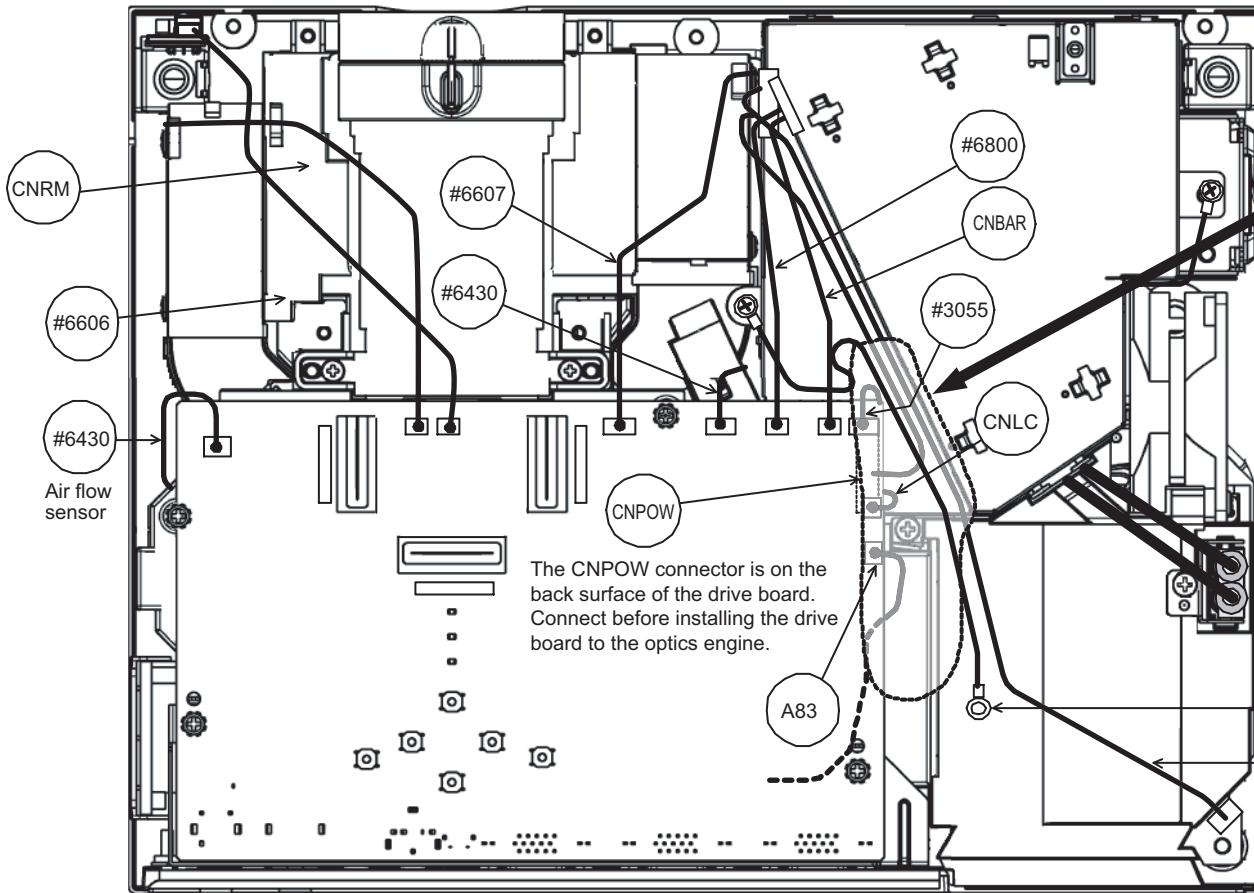

WARNING
 After confirm that TSW is printed with YS11A120A-**, orient its printed surface inward (toward lamp housing) and install it.

Wiring diagram 5 (C9SM/C9X/C9XM)

Wiring when installing lamp shield

- When installing lamp shield
- (1) Wire TSW.
 - (2) Connect and wire CNSH.

WARNING

Screw the lamp shield to power supply unit.

Lamp shield

Power supply unit

WARNING

Lamp shield

Gasket

Power supply unit

Confirm that the gasket is attached to Power supply unit

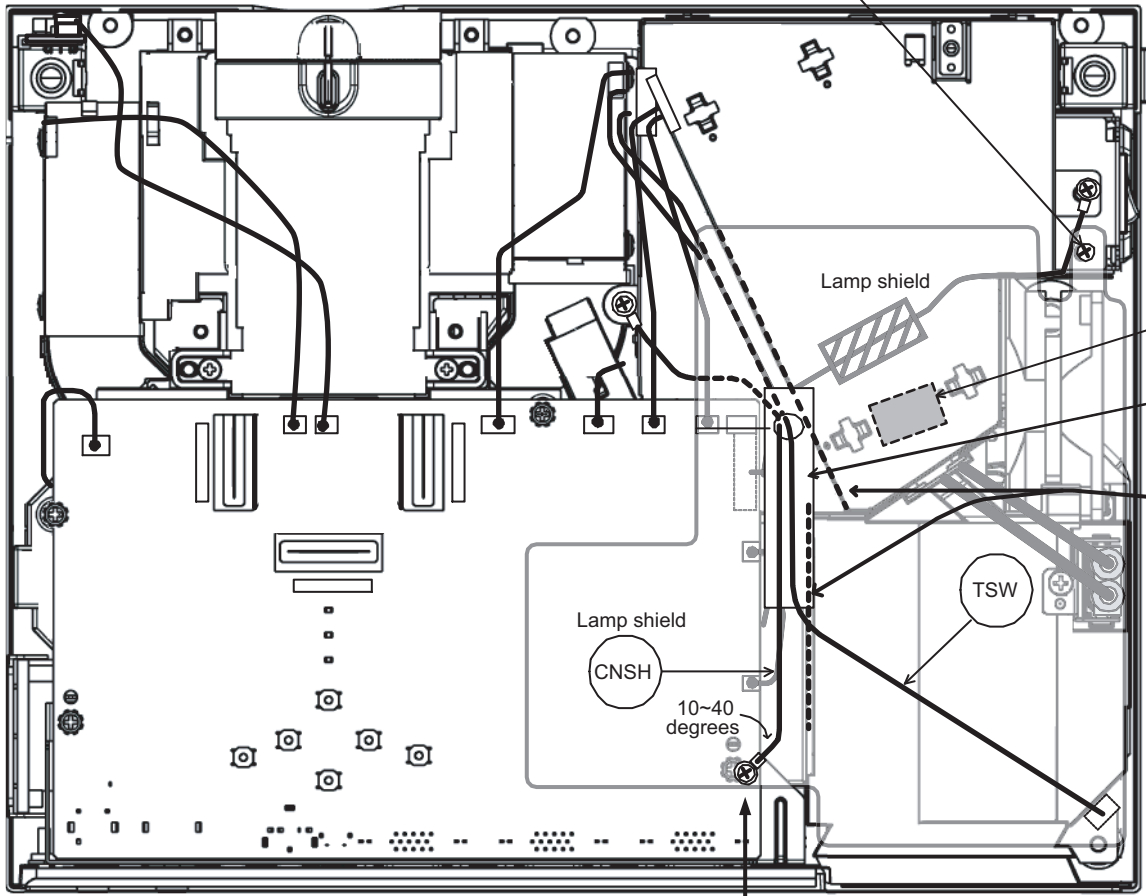

Tape down CNSH and TSW at the positions shown at left.

Style TSW and CNSH to avoid the power source under the lamp shield, and the lamp housing, because overlapping these causes the upper case to bulge.

WARNING

Lamp shield

CNSH

I/O METAL

Screw CNSH to I/O METAL with lamp shield.

Wiring diagram 6 (C9SM/C9X/C9XM)

8. Disassembly diagram

M: Meter Screw
T: Tapping Screw

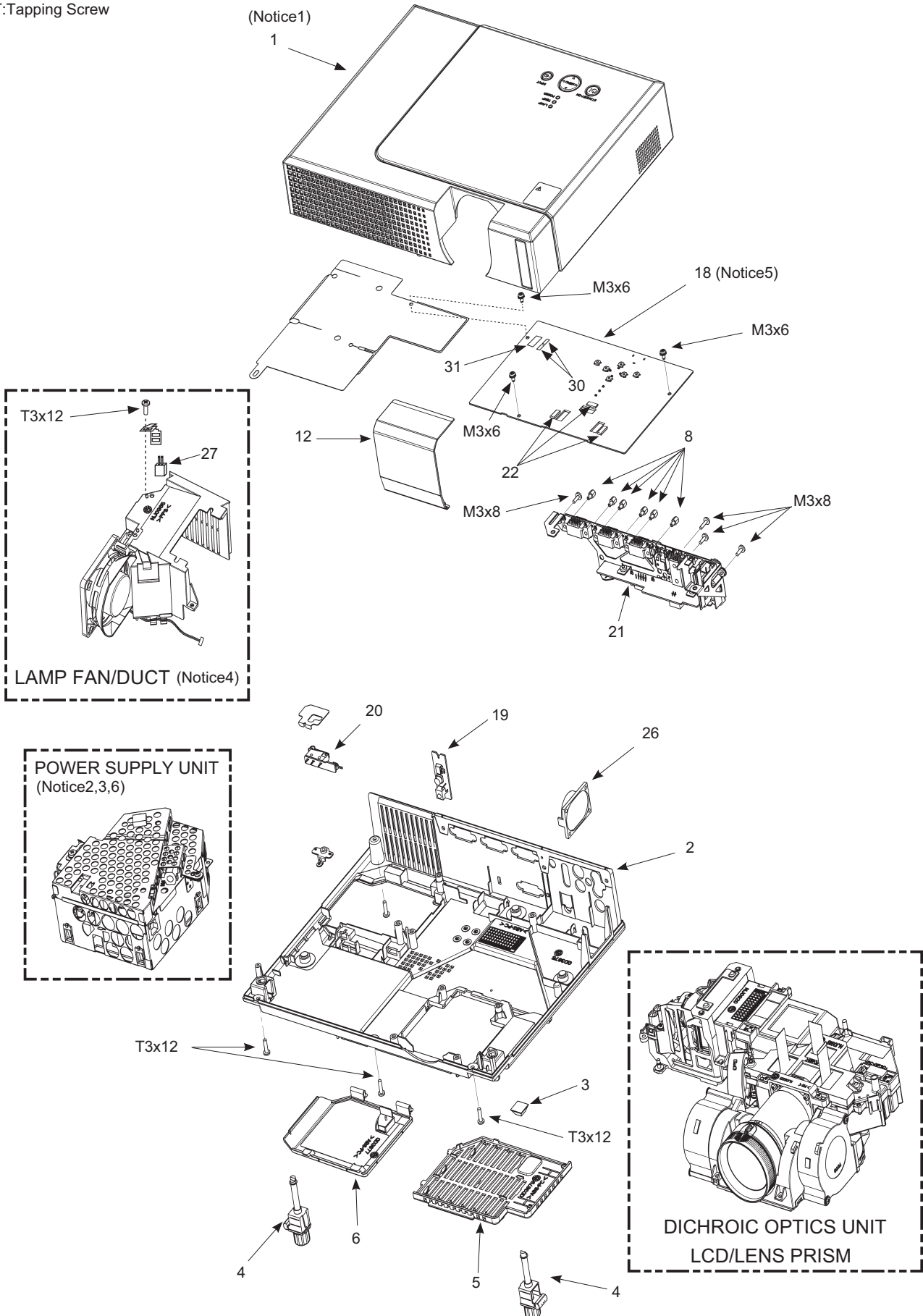

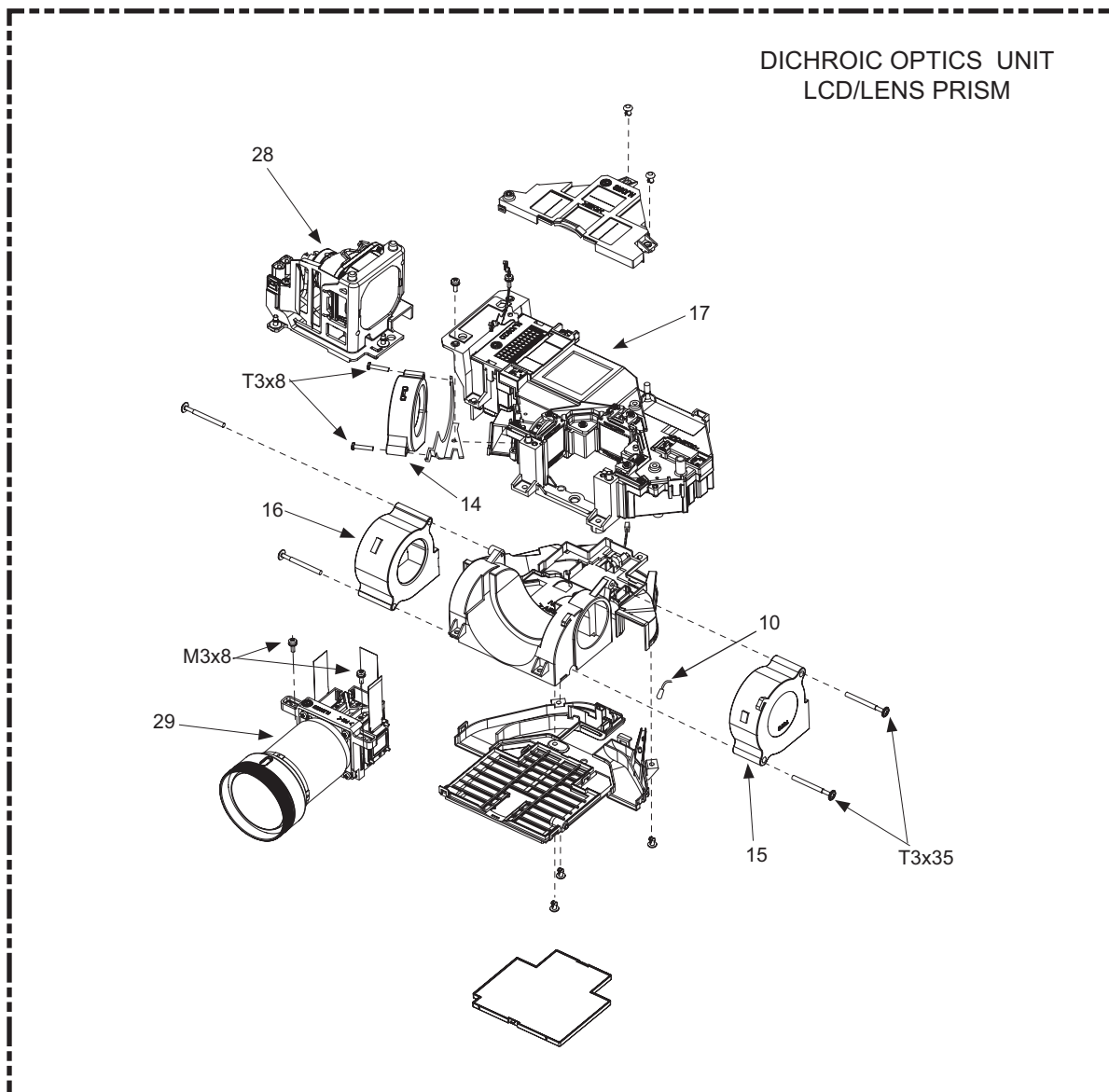
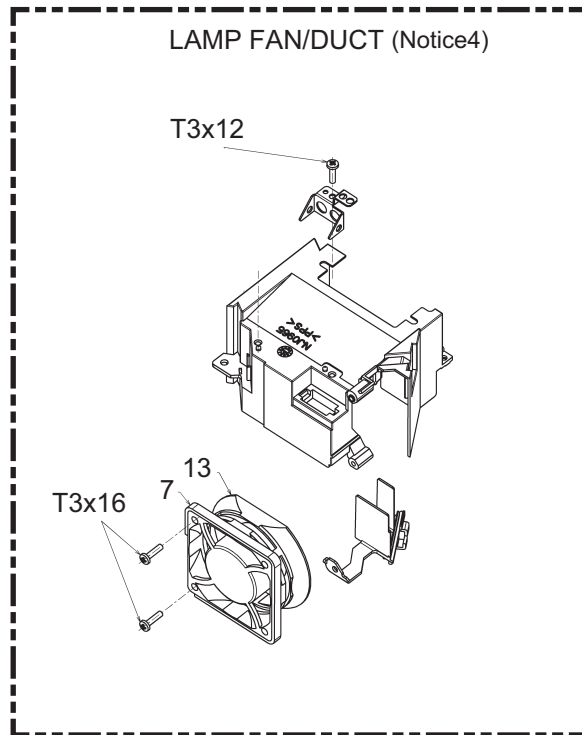
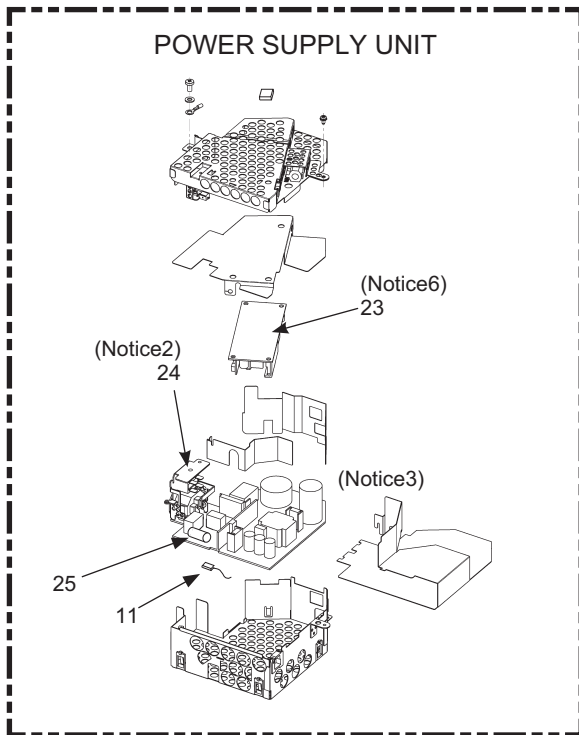

Notice

1. Attaches UPPER CASE assembly

The screw hole (a4) is weaker than the others (a1),(a2) and (a3).

Tighten this screw carefully in accordance with screw torque below.

Screw torque : 0.6 to 0.9Nm(6 to 9kgm)

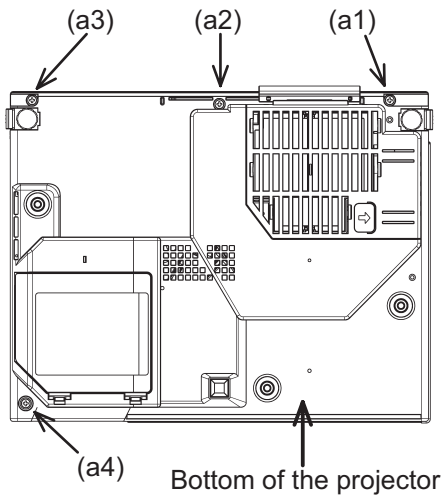

2. Removes POWER BOARD(CIRCUIT)

(1) Unscrew two screws and remove a plastic rivet, and then get the BALLAST-BRACKET off.

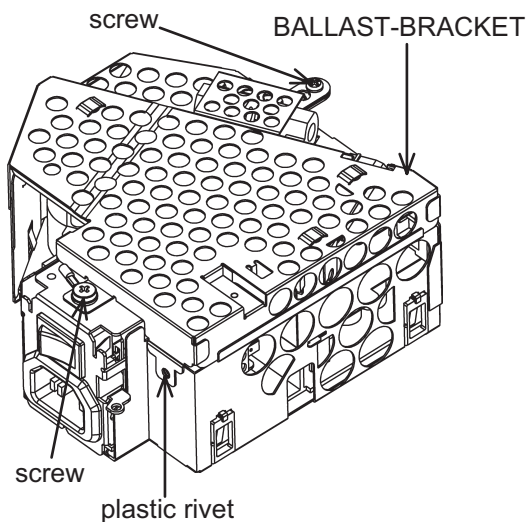

(2) Take the Power Center Sheet and the Power Side Sheet off.

Next, get POWER BOARD(CIRCUIT) off as unclipping three holders and a POWER-BRACKET hook.

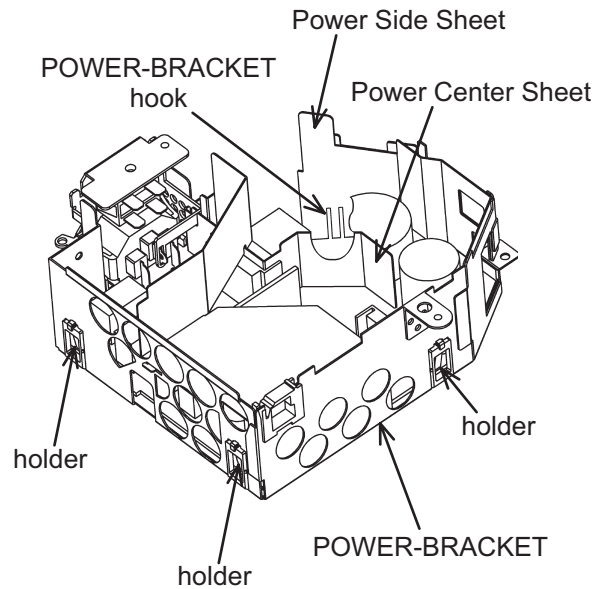

NOTE:

In removing POWER BOARD(CIRCUIT), use flat screw driver or fine tool to unclip the holder with the arrow shown below.

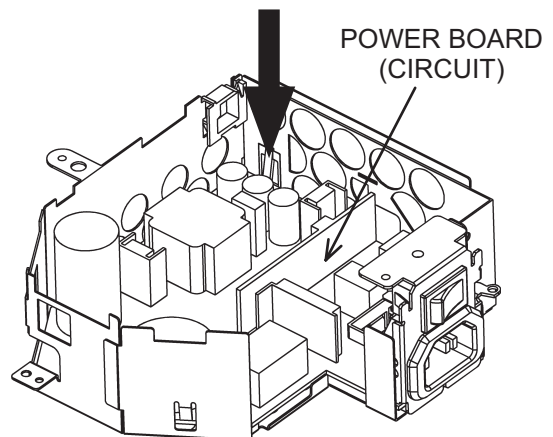

3. Putting the power supply unit together after the maintenance of the POWER UNIT (CIRCUIT) and/or the POWER UNIT (BALLAST).

⚠ WARNING

Assemble the power supply unit with care to achieve the required insulation. Incorrect assembly could cause a fire and/or an electric shock.

- (1) Attaching the Power Center Sheet

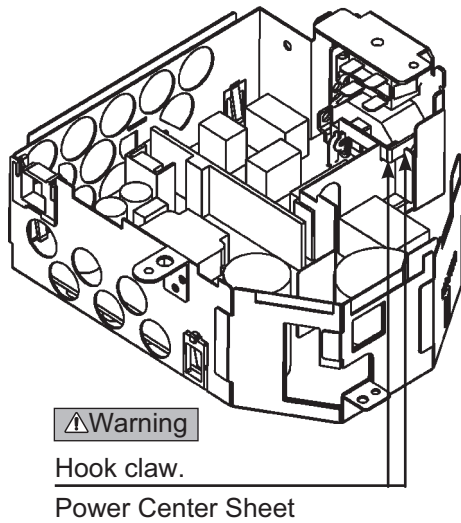

- (2) Attaching the Power Side Sheet

⚠ Warning
Insert sheet between POWER BOARD (CIRCUIT) and the Power Side Sheet.

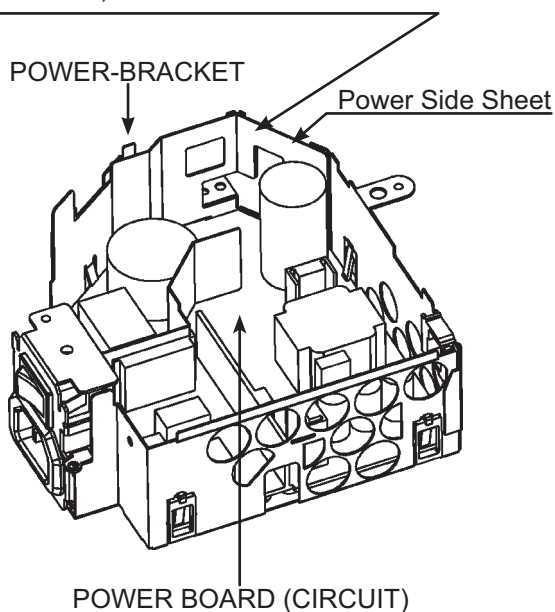

- (3) Attaching the Power Sheet

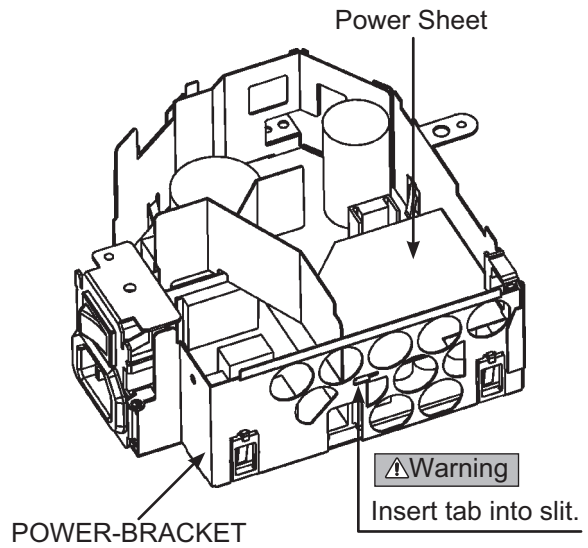

⚠ Warning

Attach Power Sheet so that its shaded edge cannot contact to POWER UNIT (BALLAST).

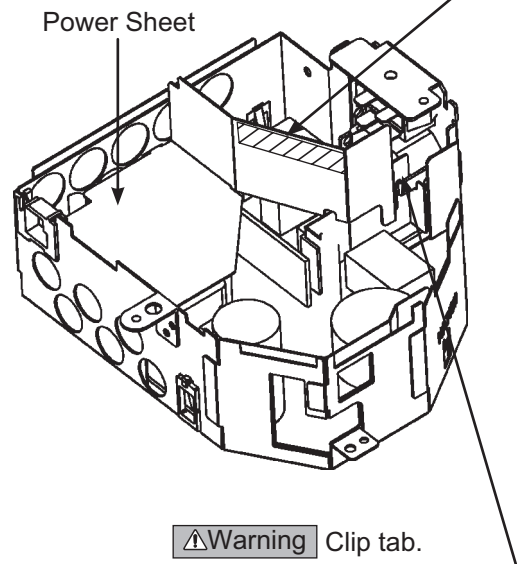

CP-S335(C9SM)/CP-X340, PJ552 (C9X)/CP-X345, PJ562 (C9XM)

4. Please follow the procedure below in removing the LAMP FAN/DUCT at maintenance; remove the POWER UNIT prior to the LAMP FAN/DUCT, because the WIRE is routed underneath the POWER SUPPLY UNIT.

1) Unscrew the SCREW-1 and SCREW-2, and remove the POWER SUPPLY UNIT.

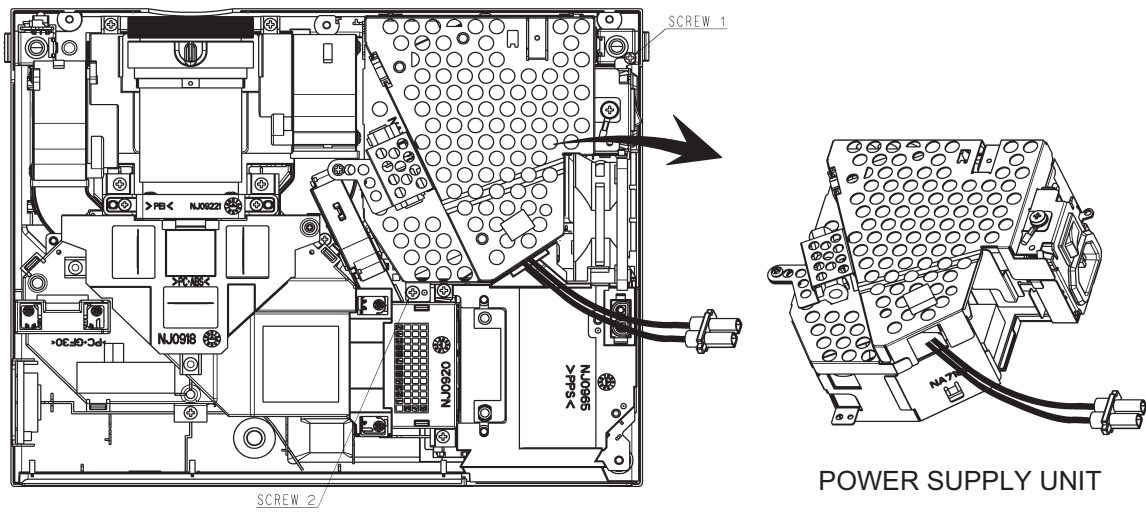

2) After remove the SCREW-3 and TAPE, lift and remove the LAMP FAN/DUCT.

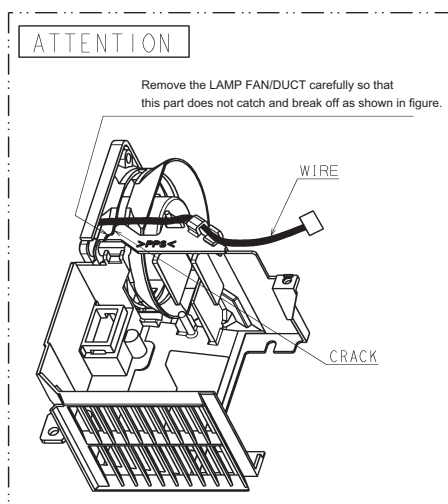
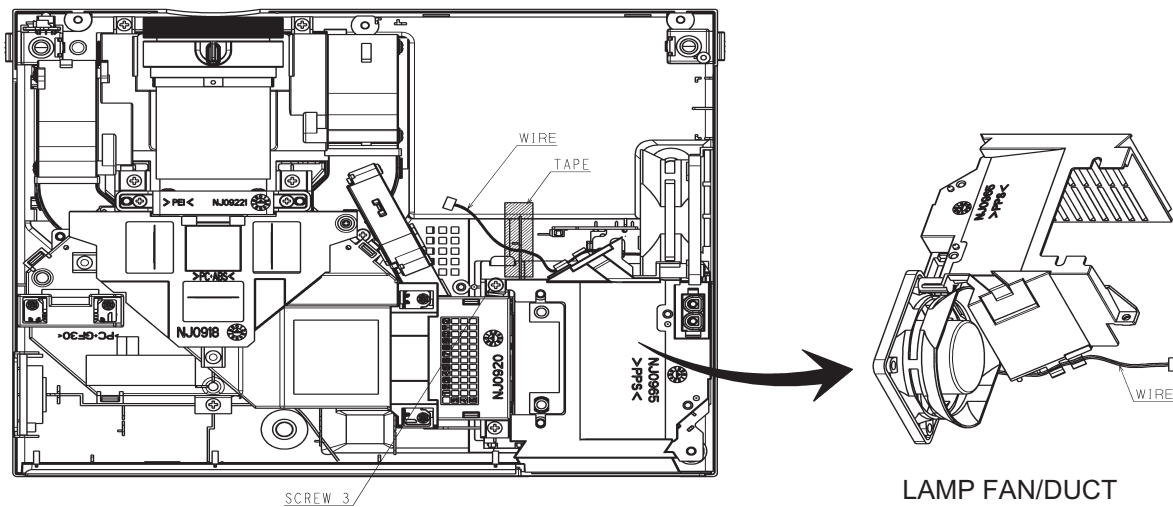

CP-S335(C9SM)/CP-X340, PJ552 (C9X)/CP-X345, PJ562 (C9XM)

5. Cautions when removing the PWB assembly MAIN

When removing the PWB assembly MAIN, there is danger of damaging the connector connecting cables.

1) Disconnect 13 cables and remove 2 screws.

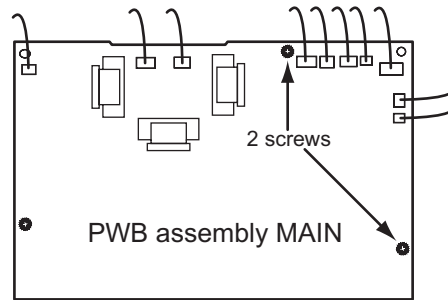

2) Remove 1 screw.

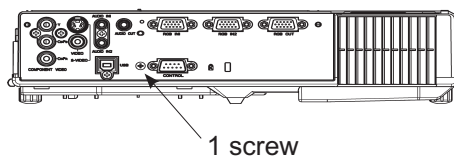

3) Lift up the rearward of the PWB assembly MAIN to the front, while pushing rear portion of bottom case toward the outside so that the terminals of MAIN board may not be caught in bottom case. And then disconnect cable.

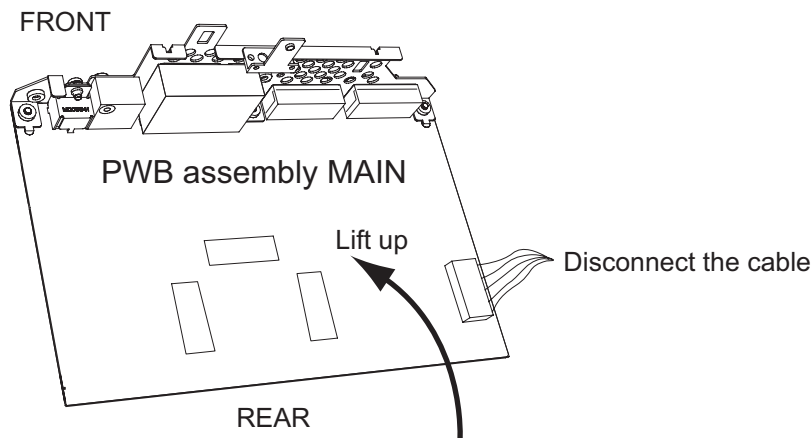

6. Cautions When Removing The Power Unit (BALLAST)

When removing the cable (CNBAR) connected to Power Unit (BALLAST), there is danger of damaging the small PWB connecting cables.

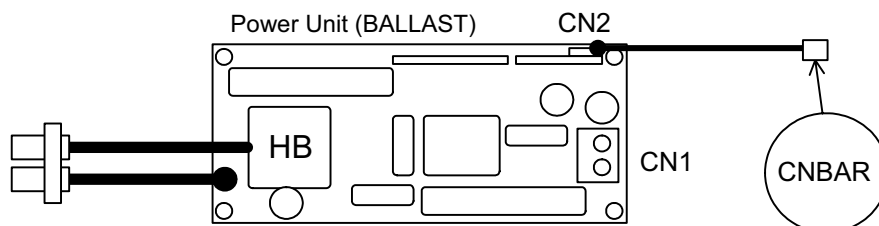

Disconnect the CNBAR from connector CN2, while pressing the sub-board (to prevent the stress on the sub-board).

9. Parts list

PRODUCT SAFETY NOTE : Components marked with a \triangle have special characteristics important to safety. Before replacing any of these components, read carefully, the PRODUCT SAFETY NOTICE of this Service Manual. Don't degrade the safety of the projector through improper servicing.

● CP-S335

| SYMBOL NO. | DESCRIPTION | SYMBOL NO. | DESCRIPTION |
|----------------|----------------------|----------------|---|
| 1 | UPPER CASE SASS'Y | \triangle 24 | POWER UNIT(CIRCUIT) |
| 2 | BOTTOM CASE SASS'Y | \triangle 25 | FUSE 6.3A |
| 3 | RUBBER FOOT | 26 | SPEAKER |
| 4 | ADJUST FOOT | \triangle 27 | TEMP. SENSOR |
| 5 | FILTER COVER ASS'Y | \triangle 28 | LAMP UNIT ASS'Y |
| 6 | LAMP DOOR ASS'Y | 29 | LCD/LENS PRISM ASS'Y(SERVICE or REPAIR) |
| 7 | FAN CUSHION A2 C9 | 30 | EL8302IU-T7 |
| 8 | D-SUB SCREW | 31 | SN74F157ANSR |
| 9 | AIR FILTER ASSY S | | |
| 10 | THERMISTOR A | | |
| 11 | THERMISTOR B | | INSTRUCTION MANUAL SASSY W/CD-ROM |
| 12 | LENS SHUTTER ASSY | | FILTER COVER HAS C9 |
| \triangle 13 | DC FAN(LAMP) | | REMOTE CONTROL UNIT |
| \triangle 14 | DC FAN(PBS) | | POWER SUPPLY CORD(US TYPE) W/CORE |
| \triangle 15 | DC FAN(PANEL B) | | POWER SUPPLY CORD(EUROPE TYPE) W/CORE |
| \triangle 16 | DC FAN(PANEL RG) | | POWER SUPPLY CORD(UK TYPE) W/CORE |
| 17 | DICHROIC OPTICS UNIT | | RGB-D CABLE(15PIN MALE TO 15PIN MALE) |
| 18 | PWB ASS'Y MAIN | | COTTON STICK L147 |
| 19 | PWB ASS'Y REMOTE | | |
| 20 | PWB ASS'Y SW | | |
| 21 | PWB ASS'Y CONTROL | | |
| 22 | CPC30 CONNECTOR | | |
| \triangle 23 | POWER UNIT(BALLAST) | | |

● CP-X340

| SYMBOL NO. | DESCRIPTION | SYMBOL NO. | DESCRIPTION |
|----------------|----------------------|----------------|---|
| 1 | UPPER CASE SASS'Y | \triangle 24 | POWER UNIT(CIRCUIT) |
| 2 | BOTTOM CASE SASS'Y | \triangle 25 | FUSE 6.3A |
| 3 | RUBBER FOOT | 26 | SPEAKER |
| 4 | ADJUST FOOT | \triangle 27 | TEMP. SENSOR |
| 5 | FILTER COVER ASS'Y | \triangle 28 | LAMP UNIT ASS'Y |
| 6 | LAMP DOOR ASS'Y | 29 | LCD/LENS PRISM ASS'Y(SERVICE or REPAIR) |
| 7 | FAN CUSHION A C9 | 30 | EL8302IU-T7 |
| 8 | D-SUB SCREW | 31 | SN74F157ANSR |
| 9 | AIR FILTER ASSY S | | |
| 10 | THERMISTOR A | | |
| 11 | THERMISTOR B | | ANUAL SASSY |
| 12 | LENS SHUTTER ASSY | | FILTER COVER HAS C9 |
| \triangle 13 | DC FAN(LAMP) | | REMOTE CONTROL UNIT |
| \triangle 14 | DC FAN(PBS) | | POWER SUPPLY CORD(US TYPE) W/CORE |
| \triangle 15 | DC FAN(PANEL B) | | POWER SUPPLY CORD(EUROPE TYPE) W/CORE |
| \triangle 16 | DC FAN(PANEL RG) | | POWER SUPPLY CORD(UK TYPE) W/CORE |
| 17 | DICHROIC OPTICS UNIT | | RGB-D CABLE(15PIN MALE TO 15PIN MALE) |
| 18 | PWB ASS'Y MAIN | | COTTON STICK L147 |
| 19 | PWB ASS'Y REMOTE | | |
| 20 | PWB ASS'Y SW | | |
| 21 | PWB ASS'Y CONTROL | | |
| 22 | CPC30 CONNECTOR | | |
| \triangle 23 | POWER UNIT(BALLAST) | | |

CP-S335(C9SM)/CP-X340, PJ552 (C9X)/CP-X345, PJ562 (C9XM)

● CP-X345

| SYMBOL NO. | DESCRIPTION | SYMBOL No. | DESCRIPTION |
|------------|----------------------|------------|---|
| 1 | UPPER CASE SASS'Y | ⚠ 24 | POWER UNIT(CIRCUIT) |
| 2 | BOTTOM CASE SASS'Y | ⚠ 25 | FUSE 6.3A |
| 3 | RUBBER FOOT | 26 | SPEAKER |
| 4 | ADJUST FOOT | ⚠ 27 | TEMP. SENSOR |
| 5 | FILTER COVER ASS'Y | ⚠ 28 | LAMP UNIT ASS'Y |
| 6 | LAMP DOOR ASS'Y | 29 | LCD/LENS PRISM ASS'Y(SERVICE or REPAIR) |
| 7 | FAN CUSHION A2 C9 | 30 | EL8302IU-T7 |
| 8 | D-SUB SCREW | 31 | SN74F157ANSR |
| 9 | AIR FILTER ASSY S | | |
| 10 | THERMISTOR A | | |
| 11 | THERMISTOR B | | INSTRUCTION MANUAL SASSY |
| 12 | LENS SHUTTER ASSY | | FILTER COVER HAS C9 |
| ⚠ 13 | DC FAN(LAMP) | | REMOTE CONTROL UNIT |
| ⚠ 14 | DC FAN(PBS) | | POWER SUPPLY CORD(US TYPE) W/CORE |
| ⚠ 15 | DC FAN(PANEL B) | | POWER SUPPLY CORD(EUROPE TYPE) W/CORE |
| ⚠ 16 | DC FAN(PANEL RG) | | POWER SUPPLY CORD(UK TYPE) W/CORE |
| 17 | DICHROIC OPTICS UNIT | | RGB-D CABLE(15PIN MALE TO 15PIN MALE) |
| 18 | PWB ASS'Y MAIN | | COTTON STICK L147 |
| 19 | PWB ASS'Y REMOTE | | |
| 20 | PWB ASS'Y SW | | |
| 21 | PWB ASS'Y CONTROL | | |
| 22 | CPC30 CONNECTOR | | |
| ⚠ 23 | POWER UNIT(BALLAST) | | |

CP-S335(C9SM)/CP-X340, PJ552 (C9X)/CP-X345, PJ562 (C9XM)

● PJ552, PJ562

| SYMBOL NO. | PARTS NO. | DESCRIPTION | SYMBOL NO. | PARTS NO. | DESCRIPTION |
|------------|-----------|----------------------|------------|-----------|---|
| 1 | | UPPER CASE SASS'Y | ⚠ 24 | | POWER UNIT(CIRCUIT) |
| 2 | | BOTTOM CASE SASS'Y | ⚠ 25 | | FUSE 6.3A |
| 3 | | RUBBER FOOT | 26 | | SPEAKER |
| 4 | | ADJUST FOOT | ⚠ 27 | | TEMP. SENSOR |
| 5 | | FILTER COVER ASS'Y | ⚠ 28 | | LAMP UNIT ASS'Y |
| 6 | | LAMP DOOR ASS'Y | 29 | | LCD/LENS PRISM ASS'Y(SERVICE or REPAIR) |
| 7 | | FAN CUSHION A C9 | | | |
| 8 | | D-SUB SCREW | | | INSTRUCTION MANUAL SASSY |
| 9 | | AIR FILTER ASSY S | | | FILTER COVER HAS C9 |
| 10 | | THERMISTOR A | | | REMOTE CONTROL UNIT |
| 11 | | THERMISTOR B | | | POWER SUPPLY CORD(US TYPE) W/CORE |
| 12 | | LENS CAP | | | POWER SUPPLY CORD(EUROPE TYPE) W/CORE |
| ⚠ 13 | | DC FAN(LAMP) | | | POWER SUPPLY CORD(UK TYPE) W/CORE |
| ⚠ 14 | | DC FAN(PBS) | | | RGB-D CABLE(15PIN MALE TO 15PIN MALE) |
| ⚠ 15 | | DC FAN(PANEL B) | | | COTTON STICK L147 |
| ⚠ 16 | | DC FAN(PANEL RG) | | | VIDEO CABLE |
| 17 | | DICHROIC OPTICS UNIT | | | SOFT CASE |
| 18 | | PWB ASS'Y MAIN | | | |
| 19 | | PWB ASS'Y REMOTE | | | |
| 20 | | PWB ASS'Y SW | | | |
| 21 | | PWB ASS'Y CONTROL | | | |
| 22 | | CPC30 CONNECTOR | | | |
| ⚠ 23 | | POWER UNIT(BALLAST) | | | |

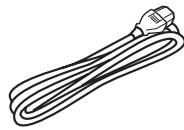

Power Cord

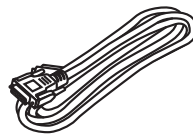

RGB Cable

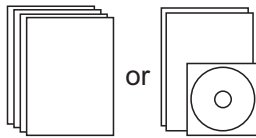

Instruction manual

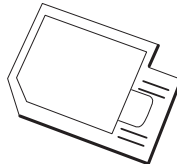

Filter Cover HAS C9

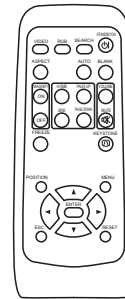

Remote Control

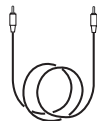

Video Cable
(PJ552, PJ562 only)

**THE UPDATED PARTS LIST
FOR THIS MODEL IS
AVAILABLE ON ESTA**

10. RS-232C communication

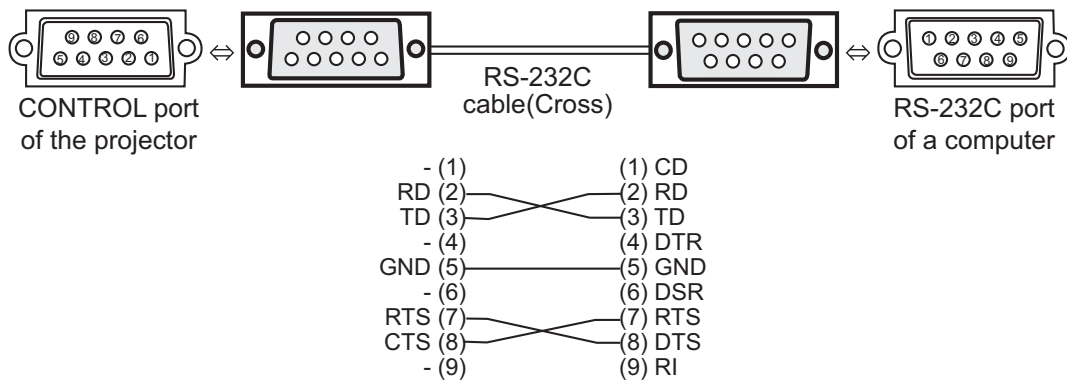

● Connecting the cable

- (1) Turn off the projector and the computer power supplies.
- (2) Connect the CONTROL port of the projector with a RS-232C port of the computer by a RS-232C cable(Cross). Use the cable that fulfills the specification shown in the previous page.
- (3) Turn on the computer power supply and after the computer has started up, turn on the projector power supply.

● Communications setting

19200 bps, 8N1

1. Protocol

Consist of header (7 bytes) + Command data (6 bytes)

2. Header

BE + EF + 03 + 06 + 00 + CRC_low + CRC_high

CRC_low: Lower byte of CRC flag for command data

CRC_high: Upper byte of CRC flag for command data

3. Command Data

Command Data Chart

| byte_0 | byte_1 | byte_2 | byte_3 | byte_4 | byte_5 |
|--------|--------|--------|--------|--------------|--------|
| Action | | Type | | Setting code | |
| low | high | low | high | low | high |

Action (byte_0 - 1)

| Action | Classification | Content |
|--------|----------------|--------------------------------------|
| 1 | Set | Change setting to desired value. |
| 2 | Get | Read projector internal setup value. |
| 4 | Increment | Increment setup value by 1. |
| 5 | Decrement | Decrement setup value by 1. |
| 6 | Execute | Run a command. |

Requesting projector status (Get command)

- (1) Send the request code Header + Command data ('02H'+ '00H'+ type (2 bytes)+ '00H'+ '00H') from the computer to the projector.
- (2) The projector returns the response code '1DH'+ data (2 bytes) to the computer.

Changing the projector settings (Set command)

- (1) Send the setting code Header + Command data ('01H'+ '00H'+ type (2 bytes) + setting code (2 bytes)) from the computer to the projector.
- (2) The projector changes the setting based on the above setting code.
- (3) The projector returns the response code '06H' to the computer.

Using the projector default settings (Reset Command)

- (1) The computer sends the default setting code Header + Command data ('06H'+ '00H'+ type (2 bytes) + '00H'+ '00H') to the projector.
- (2) The projector changes the specified setting to the default value.
- (3) The projector returns the response code '06H' to the computer.

Increasing the projector setting value (Increment command)

- (1) The computer sends the increment code Header + Command data ('04H'+ '00H'+ type (2 bytes) + '00H'+ '00H') to the projector.
- (2) The projector increases the setting value on the above setting code.
- (3) The projector returns the response code '06H' to the computer.

Decreasing the projector setting value (Decrement command)

- (1) The computer sends the decrement code Header + Command data ('05H'+ '00H'+ type (2 bytes) + '00H'+ '00H') to the projector.
- (2) The projector decreases the setting value on the above setting code.
- (3) The projector returns the response code '06H' to the computer.

When the projector cannot understand the received command

When the projector cannot understand the received command, the error code '15H' is sent back to the computer.

Sometimes the projector cannot properly receive the command. In such a case, the command is not executed and the error code '15H' is sent back to the computer. If this error code is returned, send the same command again.

When the projector cannot execute the received command.

When the projector cannot execute the received command, the error code '1cH' + 'xxxxH' is sent back to the computer. When the data length is greater than indicated by the data length code, the projector ignore the excess data code.

Conversely when the data length is shorter than indicated by the data length code, an error code will be returned to the computer.

NOTE • Operation cannot be guaranteed when the projector receives an undefined command or data.
• Provide an interval of at least 40ms between the response code and any other code.
• The projector outputs test data when the power supply is switched ON, and when the lamp is lit. Ignore this data.
• Commands are not accepted during warm-up.

● Command data chart

| Names | Operation Type | Header | | | | Command Data | | | | |
|----------------|----------------|------------------|-------------------|------------------------|----------------------|-----------------------|-----------------------|---------------------------|----------------------------|-----------------------|
| | | | | | CRC | Action | Type | Setting Code | | |
| Power | Set | Turn off | BE EF | 03 | 06 00 | 2A D3 | 01 00 | 00 60 | 00 00 | |
| | | Turn on | BE EF | 03 | 06 00 | BA D2 | 01 00 | 00 60 | 01 00 | |
| | Get | | BE EF | 03 | 06 00 | 19 D3 | 02 00 | 00 60 | 00 00 | |
| | | (Example return) | 00 00 (Off) | 01 00 (On) | 02 00 (Cool down) | | | | | |
| Input Source | Set | RGB IN1 | BE EF | 03 | 06 00 | FE D2 | 01 00 | 00 20 | 00 00 | |
| | | RGB IN2 | BE EF | 03 | 06 00 | 3E D0 | 01 00 | 00 20 | 04 00 | |
| | | VIDEO | BE EF | 03 | 06 00 | 6E D3 | 01 00 | 00 20 | 01 00 | |
| | | S-VIDEO | BE EF | 03 | 06 00 | 9E D3 | 01 00 | 00 20 | 02 00 | |
| | | COMPONENT | BE EF | 03 | 06 00 | AE D1 | 01 00 | 00 20 | 05 00 | |
| | Get | BE EF | 03 | 06 00 | CD D2 | 02 00 | 00 20 | 00 00 | | |
| Error Status | Get | BE EF | 03 | 06 00 | D9 D8 | 02 00 | 20 60 | 00 00 | | |
| | | (Example return) | 00 00 (Normal) | 01 00 (Cover error) | 02 00 (Fan error) | 03 00 (Lamp error) | 04 00 (Temp error) | 05 00 (Air flow error) | 06 00 (Lamp time error) | 07 00 (Cool error) |
| BRIGHT | Get | | BE EF | 03 | 06 00 | 89 D2 | 02 00 | 03 20 | 00 00 | |
| | | Increment | BE EF | 03 | 06 00 | EF D2 | 04 00 | 03 20 | 00 00 | |
| | | Decrement | BE EF | 03 | 06 00 | 3E D3 | 05 00 | 03 20 | 00 00 | |
| BRIGHT Reset | Execute | BE EF | 03 | 06 00 | 58 D3 | 06 00 | 00 70 | 00 00 | | |
| CONTRAST | Get | | BE EF | 03 | 06 00 | FD D3 | 02 00 | 04 20 | 00 00 | |
| | | Increment | BE EF | 03 | 06 00 | 9B D3 | 04 00 | 04 20 | 00 00 | |
| | | Decrement | BE EF | 03 | 06 00 | 4A D2 | 05 00 | 04 20 | 00 00 | |
| CONTRAST Reset | Execute | BE EF | 03 | 06 00 | A4 D2 | 06 00 | 01 70 | 00 00 | | |
| MODE | Set | NORMAL | BE EF | 03 | 06 00 | 23 F6 | 01 00 | BA 30 | 00 00 | |
| | | CINEMA | BE EF | 03 | 06 00 | B3 F7 | 01 00 | BA 30 | 01 00 | |
| | | DYNAMIC | BE EF | 03 | 06 00 | E3 F4 | 01 00 | BA 30 | 04 00 | |
| | Get | BE EF | 03 | 06 00 | 10 F6 | 02 00 | BA 30 | 00 00 | | |
| | | (Example return) | 00 00 (Normal) | 01 00 (Cinema) | 04 00 (Dynamic) | 10 00 (Custom) | | | | |
| GAMMA | Set | #1 DEFAULT | BE EF | 03 | 06 00 | 07 E9 | 01 00 | A1 30 | 20 00 | |
| | | #1 CUSTOM | BE EF | 03 | 06 00 | 07 FD | 01 00 | A1 30 | 10 00 | |
| | | #2 DEFAULT | BE EF | 03 | 06 00 | 97 E8 | 01 00 | A1 30 | 21 00 | |
| | | #2 CUSTOM | BE EF | 03 | 06 00 | 97 FC | 01 00 | A1 30 | 11 00 | |
| | | #3 DEFAULT | BE EF | 03 | 06 00 | 67 E8 | 01 00 | A1 30 | 22 00 | |
| | | #3 CUSTOM | BE EF | 03 | 06 00 | 67 FC | 01 00 | A1 30 | 12 00 | |
| | Get | BE EF | 03 | 06 00 | F4 F0 | 02 00 | A1 30 | 00 00 | | |

CP-S335(C9SM)/CP-X340, PJ552 (C9X)/CP-X345, PJ562 (C9XM)

| Names | Operation Type | Header | | | | Command Data | | | |
|--------------------|----------------|---------------------|-------|-------|-------|--------------|-------|--------------|-------|
| | | | | | CRC | Action | Type | Setting Code | |
| User Gamma Pattern | Set | Off | BE EF | 03 | 06 00 | FB FA | 01 00 | 80 30 | 00 00 |
| | | 9 step gray scale | BE EF | 03 | 06 00 | 6B FB | 01 00 | 80 30 | 01 00 |
| | | 15 steps gray scale | BE EF | 03 | 06 00 | 9B FB | 01 00 | 80 30 | 02 00 |
| | | Ramp | BE EF | 03 | 06 00 | 0B FA | 01 00 | 80 30 | 03 00 |
| | Get | BE EF | 03 | 06 00 | C8 FA | 02 00 | 80 30 | 00 00 | |
| User Gamma Point 1 | Get | BE EF | 03 | 06 00 | 08 FE | 02 00 | 90 30 | 00 00 | |
| | Increment | BE EF | 03 | 06 00 | 6E FE | 04 00 | 90 30 | 00 00 | |
| | Decrement | BE EF | 03 | 06 00 | BF FF | 05 00 | 90 30 | 00 00 | |
| User Gamma Point 2 | Get | BE EF | 03 | 06 00 | F4 FF | 02 00 | 91 30 | 00 00 | |
| | Increment | BE EF | 03 | 06 00 | 92 FF | 04 00 | 91 30 | 00 00 | |
| | Decrement | BE EF | 03 | 06 00 | 43 FE | 05 00 | 91 30 | 00 00 | |
| User Gamma Point 3 | Get | BE EF | 03 | 06 00 | B0 FF | 02 00 | 92 30 | 00 00 | |
| | Increment | BE EF | 03 | 06 00 | D6 FF | 04 00 | 92 30 | 00 00 | |
| | Decrement | BE EF | 03 | 06 00 | 07 FE | 05 00 | 92 30 | 00 00 | |
| User Gamma Point 4 | Get | BE EF | 03 | 06 00 | 4C FE | 02 00 | 93 30 | 00 00 | |
| | Increment | BE EF | 03 | 06 00 | 2A FE | 04 00 | 93 30 | 00 00 | |
| | Decrement | BE EF | 03 | 06 00 | FB FF | 05 00 | 93 30 | 00 00 | |
| User Gamma Point 5 | Get | BE EF | 03 | 06 00 | 38 FF | 02 00 | 94 30 | 00 00 | |
| | Increment | BE EF | 03 | 06 00 | 5E FF | 04 00 | 94 30 | 00 00 | |
| | Decrement | BE EF | 03 | 06 00 | 8F FE | 05 00 | 94 30 | 00 00 | |
| User Gamma Point 6 | Get | BE EF | 03 | 06 00 | C4 FE | 02 00 | 95 30 | 00 00 | |
| | Increment | BE EF | 03 | 06 00 | A2 FE | 04 00 | 95 30 | 00 00 | |
| | Decrement | BE EF | 03 | 06 00 | 73 FF | 05 00 | 95 30 | 00 00 | |
| User Gamma Point 7 | Get | BE EF | 03 | 06 00 | 80 FE | 02 00 | 96 30 | 00 00 | |
| | Increment | BE EF | 03 | 06 00 | E6 FE | 04 00 | 96 30 | 00 00 | |
| | Decrement | BE EF | 03 | 06 00 | 37 FF | 05 00 | 96 30 | 00 00 | |
| User Gamma Point 8 | Get | BE EF | 03 | 06 00 | 7C FF | 02 00 | 97 30 | 00 00 | |
| | Increment | BE EF | 03 | 06 00 | 1A FF | 04 00 | 97 30 | 00 00 | |
| | Decrement | BE EF | 03 | 06 00 | CB FE | 05 00 | 97 30 | 00 00 | |
| COLOR TEMP | Set | LOW | BE EF | 03 | 06 00 | 6B F4 | 01 00 | B0 30 | 01 00 |
| | | MIDDLE | BE EF | 03 | 06 00 | 9B F4 | 01 00 | B0 30 | 02 00 |
| | | HIGH | BE EF | 03 | 06 00 | 0B F5 | 01 00 | B0 30 | 03 00 |
| | | CUSTOM | BE EF | 03 | 06 00 | 3B F8 | 01 00 | B0 30 | 10 00 |
| | Get | BE EF | 03 | 06 00 | C8 F5 | 02 00 | B0 30 | 00 00 | |
| COLOR TEMP GAIN R | Get | BE EF | 03 | 06 00 | 34 F4 | 02 00 | B1 30 | 00 00 | |
| | Increment | BE EF | 03 | 06 00 | 52 F4 | 04 00 | B1 30 | 00 00 | |
| | Decrement | BE EF | 03 | 06 00 | 83 F5 | 05 00 | B1 30 | 00 00 | |

CP-S335(C9SM)/CP-X340, PJ552 (C9X)/CP-X345, PJ562 (C9XM)

| Names | Operation Type | Header | | | | Command Data | | | |
|---------------------|----------------|----------|-------|-------|-------|--------------|--------|-------|--------------|
| | | | | | | CRC | Action | Type | Setting Code |
| COLOR TEMP GAIN G | Get | BE EF | 03 | 06 00 | 70 F4 | 02 00 | B2 30 | 00 00 | |
| | Increment | BE EF | 03 | 06 00 | 16 F4 | 04 00 | B2 30 | 00 00 | |
| | Decrement | BE EF | 03 | 06 00 | C7 F5 | 05 00 | B2 30 | 00 00 | |
| COLOR TEMP GAIN B | Get | BE EF | 03 | 06 00 | 8C F5 | 02 00 | B3 30 | 00 00 | |
| | Increment | BE EF | 03 | 06 00 | EA F5 | 04 00 | B3 30 | 00 00 | |
| | Decrement | BE EF | 03 | 06 00 | 3B F4 | 05 00 | B3 30 | 00 00 | |
| COLOR TEMP OFFSET R | Get | BE EF | 03 | 06 00 | 04 F5 | 02 00 | B5 30 | 00 00 | |
| | Increment | BE EF | 03 | 06 00 | 62 F5 | 04 00 | B5 30 | 00 00 | |
| | Decrement | BE EF | 03 | 06 00 | B3 F4 | 05 00 | B5 30 | 00 00 | |
| COLOR TEMP OFFSET G | Get | BE EF | 03 | 06 00 | 40 F5 | 02 00 | B6 30 | 00 00 | |
| | Increment | BE EF | 03 | 06 00 | 26 F5 | 04 00 | B6 30 | 00 00 | |
| | Decrement | BE EF | 03 | 06 00 | F7 F4 | 05 00 | B6 30 | 00 00 | |
| COLOR TEMP OFFSET B | Get | BE EF | 03 | 06 00 | BC F4 | 02 00 | B7 30 | 00 00 | |
| | Increment | BE EF | 03 | 06 00 | DA F4 | 04 00 | B7 30 | 00 00 | |
| | Decrement | BE EF | 03 | 06 00 | 0B F5 | 05 00 | B7 30 | 00 00 | |
| COLOR | Get | BE EF | 03 | 06 00 | B5 72 | 02 00 | 02 22 | 00 00 | |
| | Increment | BE EF | 03 | 06 00 | D3 72 | 04 00 | 02 22 | 00 00 | |
| | Decrement | BE EF | 03 | 06 00 | 02 73 | 05 00 | 02 22 | 00 00 | |
| COLOR Reset | Execute | BE EF | 03 | 06 00 | 80 D0 | 06 00 | 0A 70 | 00 00 | |
| TINT | Get | BE EF | 03 | 06 00 | 49 73 | 02 00 | 03 22 | 00 00 | |
| | Increment | BE EF | 03 | 06 00 | 2F 73 | 04 00 | 03 22 | 00 00 | |
| | Decrement | BE EF | 03 | 06 00 | FE 72 | 05 00 | 03 22 | 00 00 | |
| TINT Reset | Execute | BE EF | 03 | 06 00 | 7C D1 | 06 00 | 0B 70 | 00 00 | |
| SHARPNESS | Get | BE EF | 03 | 06 00 | F1 72 | 02 00 | 01 22 | 00 00 | |
| | Increment | BE EF | 03 | 06 00 | 97 72 | 04 00 | 01 22 | 00 00 | |
| | Decrement | BE EF | 03 | 06 00 | 46 73 | 05 00 | 01 22 | 00 00 | |
| SHARPNESS Reset | Execute | BE EF | 03 | 06 00 | C4 D0 | 06 00 | 09 70 | 00 00 | |
| PROGRESSIVE | Set | TURN OFF | BE EF | 03 | 06 00 | 4A 72 | 01 00 | 07 22 | 00 00 |
| | | TV | BE EF | 03 | 06 00 | DA 73 | 01 00 | 07 22 | 01 00 |
| | | FILM | BE EF | 03 | 06 00 | 2A 73 | 01 00 | 07 22 | 02 00 |
| | Get | BE EF | 03 | 06 00 | 79 72 | 02 00 | 07 22 | 00 00 | |
| MY MEMORY Load | Set | 1 | BE EF | 03 | 06 00 | 0E D7 | 01 00 | 14 20 | 00 00 |
| | | 2 | BE EF | 03 | 06 00 | 9E D6 | 01 00 | 14 20 | 01 00 |
| | | 3 | BE EF | 03 | 06 00 | 6E D6 | 01 00 | 14 20 | 02 00 |
| | | 4 | BE EF | 03 | 06 00 | FE D7 | 01 00 | 14 20 | 03 00 |
| MY MEMORY Save | Set | 1 | BE EF | 03 | 06 00 | F2 D6 | 01 00 | 15 20 | 00 00 |
| | | 2 | BE EF | 03 | 06 00 | 62 D7 | 01 00 | 15 20 | 01 00 |
| | | 3 | BE EF | 03 | 06 00 | 92 D7 | 01 00 | 15 20 | 02 00 |
| | | 4 | BE EF | 03 | 06 00 | 02 D6 | 01 00 | 15 20 | 03 00 |
| ASPECT | Set | 4:3 | BE EF | 03 | 06 00 | 9E D0 | 01 00 | 08 20 | 00 00 |
| | | 16:9 | BE EF | 03 | 06 00 | 0E D1 | 01 00 | 08 20 | 01 00 |
| | | SMALL | BE EF | 03 | 06 00 | FE D1 | 01 00 | 08 20 | 02 00 |
| | | NORMAL | BE EF | 03 | 06 00 | 5E DD | 01 00 | 08 20 | 10 00 |
| | Get | BE EF | 03 | 06 00 | AD D0 | 02 00 | 08 20 | 00 00 | |

CP-S335(C9SM)/CP-X340, PJ552 (C9X)/CP-X345, PJ562 (C9XM)

| Names | Operation Type | Header | | | | Command Data | | | |
|------------------|----------------|-----------|-------|-------|-------|--------------|--------|-------|--------------|
| | | | | | | CRC | Action | Type | Setting Code |
| OVER SCAN | Get | BE EF | 03 | 06 00 | 91 70 | 02 00 | 09 22 | 00 00 | |
| | Increment | BE EF | 03 | 06 00 | F7 70 | 04 00 | 09 22 | 00 00 | |
| | Decrement | BE EF | 03 | 06 00 | 26 71 | 05 00 | 09 22 | 00 00 | |
| OVER SCAN Reset | Execute | BE EF | 03 | 06 00 | EC D9 | 06 00 | 27 70 | 00 00 | |
| V POSITION | Get | BE EF | 03 | 06 00 | 0D 83 | 02 00 | 00 21 | 00 00 | |
| | Increment | BE EF | 03 | 06 00 | 6B 83 | 04 00 | 00 21 | 00 00 | |
| | Decrement | BE EF | 03 | 06 00 | BA 82 | 05 00 | 00 21 | 00 00 | |
| V POSITION Reset | Execute | BE EF | 03 | 06 00 | E0 D2 | 06 00 | 02 70 | 00 00 | |
| H POSITION | Get | BE EF | 03 | 06 00 | F1 82 | 02 00 | 01 21 | 00 00 | |
| | Increment | BE EF | 03 | 06 00 | 97 82 | 04 00 | 01 21 | 00 00 | |
| | Decrement | BE EF | 03 | 06 00 | 46 83 | 05 00 | 01 21 | 00 00 | |
| H POSITION Reset | Execute | BE EF | 03 | 06 00 | 1C D3 | 06 00 | 03 70 | 00 00 | |
| H PHASE | Get | BE EF | 03 | 06 00 | 49 83 | 02 00 | 03 21 | 00 00 | |
| | Increment | BE EF | 03 | 06 00 | 2F 83 | 04 00 | 03 21 | 00 00 | |
| | Decrement | BE EF | 03 | 06 00 | FE 82 | 05 00 | 03 21 | 00 00 | |
| H SIZE | Get | BE EF | 03 | 06 00 | B5 82 | 02 00 | 02 21 | 00 00 | |
| | Increment | BE EF | 03 | 06 00 | D3 82 | 04 00 | 02 21 | 00 00 | |
| | Decrement | BE EF | 03 | 06 00 | 02 83 | 05 00 | 02 21 | 00 00 | |
| H SIZE Reset | Execute | BE EF | 03 | 06 00 | 68 D2 | 06 00 | 04 70 | 00 00 | |
| AUTO ADJUST | Execute | BE EF | 03 | 06 00 | 91 D0 | 06 00 | 0A 20 | 00 00 | |
| COLOR SPACE | Set | AUTO | BE EF | 03 | 06 00 | 0E 72 | 01 00 | 04 22 | 00 00 |
| | | RGB | BE EF | 03 | 06 00 | 9E 73 | 01 00 | 04 22 | 01 00 |
| | | SMPTE240 | BE EF | 03 | 06 00 | 6E 73 | 01 00 | 04 22 | 02 00 |
| | | REC709 | BE EF | 03 | 06 00 | FE 72 | 01 00 | 04 22 | 03 00 |
| | | REC601 | BE EF | 03 | 06 00 | CE 70 | 01 00 | 04 22 | 04 00 |
| | Get | BE EF | 03 | 06 00 | 3D 72 | 02 00 | 04 22 | 00 00 | |
| COMPONENT | Set | COMPONENT | BE EF | 03 | 06 00 | 4A D7 | 01 00 | 17 20 | 00 00 |
| | | SCART RGB | BE EF | 03 | 06 00 | DA D6 | 01 00 | 17 20 | 01 00 |
| | Get | BE EF | 03 | 06 00 | 79 D7 | 02 00 | 17 20 | 00 00 | |
| VIDEO FORMAT | Set | AUTO | BE EF | 03 | 06 00 | 9E 75 | 01 00 | 00 22 | 0A 00 |
| | | NTSC | BE EF | 03 | 06 00 | FE 71 | 01 00 | 00 22 | 04 00 |
| | | PAL | BE EF | 03 | 06 00 | 6E 70 | 01 00 | 00 22 | 05 00 |
| | | SECAM | BE EF | 03 | 06 00 | 6E 75 | 01 00 | 00 22 | 09 00 |
| | | NTSC4.43 | BE EF | 03 | 06 00 | 5E 72 | 01 00 | 00 22 | 02 00 |
| | | M-PAL | BE EF | 03 | 06 00 | FE 74 | 01 00 | 00 22 | 08 00 |
| | N-PAL | BE EF | 03 | 06 00 | 0E 71 | 01 00 | 00 22 | 07 00 | |
| Get | BE EF | 03 | 06 00 | 0D 73 | 02 00 | 00 22 | 00 00 | | |

CP-S335(C9SM)/CP-X340, PJ552 (C9X)/CP-X345, PJ562 (C9XM)

| Names | Operation Type | Header | | | | Command Data | | | |
|------------------|----------------|------------|-------|-------|-------|--------------|--------|-------|--------------|
| | | | | | | CRC | Action | Type | Setting Code |
| FRAME LOCK | Set | TURN OFF | BE EF | 03 | 06 00 | CB D6 | 01 00 | 14 30 | 00 00 |
| | | TURN ON | BE EF | 03 | 06 00 | 5B D7 | 01 00 | 14 30 | 01 00 |
| | Get | BE EF | 03 | 06 00 | F8 D6 | 02 00 | 14 30 | 00 00 | |
| KEYSTONE V | Get | BE EF | 03 | 06 00 | B9 D3 | 02 00 | 07 20 | 00 00 | |
| | Increment | BE EF | 03 | 06 00 | DF D3 | 04 00 | 07 20 | 00 00 | |
| | Decrement | BE EF | 03 | 06 00 | 0E D2 | 05 00 | 07 20 | 00 00 | |
| KEYSTONE V Reset | Execute | BE EF | 03 | 06 00 | 08 D0 | 06 00 | 0C 70 | 00 00 | |
| WHISPER | Set | NORMAL | BE EF | 03 | 06 00 | 3B 23 | 01 00 | 00 33 | 00 00 |
| | | WHISPER | BE EF | 03 | 06 00 | AB 22 | 01 00 | 00 33 | 01 00 |
| | Get | BE EF | 03 | 06 00 | 08 23 | 02 00 | 00 33 | 00 00 | |
| MIRROR | Set | NORMAL | BE EF | 03 | 06 00 | C7 D2 | 01 00 | 01 30 | 00 00 |
| | | H:INVERT | BE EF | 03 | 06 00 | 57 D3 | 01 00 | 01 30 | 01 00 |
| | | V:INVERT | BE EF | 03 | 06 00 | A7 D3 | 01 00 | 01 30 | 02 00 |
| | | H&V:INVERT | BE EF | 03 | 06 00 | 37 D2 | 01 00 | 01 30 | 03 00 |
| | Get | BE EF | 03 | 06 00 | F4 D2 | 02 00 | 01 30 | 00 00 | |
| VOLUME | Get | BE EF | 03 | 06 00 | 31 D3 | 02 00 | 01 20 | 00 00 | |
| | Increment | BE EF | 03 | 06 00 | 57 D3 | 04 00 | 01 20 | 00 00 | |
| | Decrement | BE EF | 03 | 06 00 | 86 D2 | 05 00 | 01 20 | 00 00 | |
| MUTE | Set | TURN OFF | BE EF | 03 | 06 00 | 46 D3 | 01 00 | 02 20 | 00 00 |
| | | TURN ON | BE EF | 03 | 06 00 | D6 D2 | 01 00 | 02 20 | 01 00 |
| | Get | BE EF | 03 | 06 00 | 75 D3 | 02 00 | 02 20 | 00 00 | |
| LANGUAGE | Set | ENGLISH | BE EF | 03 | 06 00 | F7 D3 | 01 00 | 05 30 | 00 00 |
| | | FRANÇAIS | BE EF | 03 | 06 00 | 67 D2 | 01 00 | 05 30 | 01 00 |
| | | DEUTSCH | BE EF | 03 | 06 00 | 97 D2 | 01 00 | 05 30 | 02 00 |
| | | ESPAÑOL | BE EF | 03 | 06 00 | 07 D3 | 01 00 | 05 30 | 03 00 |
| | | ITALIANO | BE EF | 03 | 06 00 | 37 D1 | 01 00 | 05 30 | 04 00 |
| | | NORSK | BE EF | 03 | 06 00 | A7 D0 | 01 00 | 05 30 | 05 00 |
| | | NEDERLANDS | BE EF | 03 | 06 00 | 57 D0 | 01 00 | 05 30 | 06 00 |
| | | PORTUGUÊS | BE EF | 03 | 06 00 | C7 D1 | 01 00 | 05 30 | 07 00 |
| | | 日本語 | BE EF | 03 | 06 00 | 37 D4 | 01 00 | 05 30 | 08 00 |
| | | 中文 | BE EF | 03 | 06 00 | A7 D5 | 01 00 | 05 30 | 09 00 |
| | | 한글 | BE EF | 03 | 06 00 | 57 D5 | 01 00 | 05 30 | 0A 00 |
| | | SVENSKA | BE EF | 03 | 06 00 | C7 D4 | 01 00 | 05 30 | 0B 00 |
| | | РУССКИЙ | BE EF | 03 | 06 00 | F7 D6 | 01 00 | 05 30 | 0C 00 |
| | | SUOMI | BE EF | 03 | 06 00 | 67 D7 | 01 00 | 05 30 | 0D 00 |
| | POLSKI | BE EF | 03 | 06 00 | 97 D7 | 01 00 | 05 30 | 0E 00 | |
| Get | BE EF | 03 | 06 00 | C4 D3 | 02 00 | 05 30 | 00 00 | | |

CP-S335(C9SM)/CP-X340, PJ552 (C9X)/CP-X345, PJ562 (C9XM)

| Names | Operation Type | Header | | | | Command Data | | | |
|-----------------------|----------------|-----------|-------|-------|-------|--------------|-------|--------------|-------|
| | | | | | CRC | Action | Type | Setting Code | |
| MENU POSITION H | Get | BE EF | 03 | 06 00 | 04 D7 | 02 00 | 15 30 | 00 00 | |
| | Increment | BE EF | 03 | 06 00 | 62 D7 | 04 00 | 15 30 | 00 00 | |
| | Decrement | BE EF | 03 | 06 00 | B3 D6 | 05 00 | 15 30 | 00 00 | |
| MENU POSITION H Reset | Execute | BE EF | 03 | 06 00 | DC C6 | 06 00 | 43 70 | 00 00 | |
| MENU POSITION V | Get | BE EF | 03 | 06 00 | 40 D7 | 02 00 | 16 30 | 00 00 | |
| | Increment | BE EF | 03 | 06 00 | 26 D7 | 04 00 | 16 30 | 00 00 | |
| | Decrement | BE EF | 03 | 06 00 | F7 D6 | 05 00 | 16 30 | 00 00 | |
| MENU POSITION V Reset | Execute | BE EF | 03 | 06 00 | A8 C7 | 06 00 | 44 70 | 00 00 | |
| OSD BRIGHT | Get | BE EF | 03 | 06 00 | A8 D5 | 02 00 | 18 30 | 00 00 | |
| | Increment | BE EF | 03 | 06 00 | CE D5 | 04 00 | 18 30 | 00 00 | |
| | Decrement | BE EF | 03 | 06 00 | 1F D4 | 05 00 | 18 30 | 00 00 | |
| BLANK | Set | My Screen | BE EF | 03 | 06 00 | FB CA | 01 00 | 00 30 | 20 00 |
| | | ORIGINAL | BE EF | 03 | 06 00 | FB E2 | 01 00 | 00 30 | 40 00 |
| | | BLUE | BE EF | 03 | 06 00 | CB D3 | 01 00 | 00 30 | 03 00 |
| | | WHITE | BE EF | 03 | 06 00 | 6B D0 | 01 00 | 00 30 | 05 00 |
| | BLACK | BE EF | 03 | 06 00 | 9B D0 | 01 00 | 00 30 | 06 00 | |
| BLANK On/Off | Set | TURN OFF | BE EF | 03 | 06 00 | FB D8 | 01 00 | 20 30 | 00 00 |
| | | TURN ON | BE EF | 03 | 06 00 | 6B D9 | 01 00 | 20 30 | 01 00 |
| | Get | BE EF | 03 | 06 00 | C8 D8 | 02 00 | 20 30 | 00 00 | |
| START UP | Set | My Screen | BE EF | 03 | 06 00 | CB CB | 01 00 | 04 30 | 20 00 |
| | | ORIGINAL | BE EF | 03 | 06 00 | 0B D2 | 01 00 | 04 30 | 00 00 |
| | | TURN OFF | BE EF | 03 | 06 00 | 9B D3 | 01 00 | 04 30 | 01 00 |
| | Get | BE EF | 03 | 06 00 | 38 D2 | 02 00 | 04 30 | 00 00 | |
| My Screen LOCK | Set | TURN OFF | BE EF | 03 | 06 00 | 3B EF | 01 00 | C0 30 | 00 00 |
| | | TURN ON | BE EF | 03 | 06 00 | AB EE | 01 00 | C0 30 | 01 00 |
| | Get | BE EF | 03 | 06 00 | 08 EF | 02 00 | C0 30 | 00 00 | |
| Message | Set | TURN OFF | BE EF | 03 | 06 00 | 8F D6 | 01 00 | 17 30 | 00 00 |
| | | TURN ON | BE EF | 03 | 06 00 | 1F D7 | 01 00 | 17 30 | 01 00 |
| | Get | BE EF | 03 | 06 00 | BC D6 | 02 00 | 17 30 | 00 00 | |
| AUTO SEARCH | Set | TURN OFF | BE EF | 03 | 06 00 | B6 D6 | 01 00 | 16 20 | 00 00 |
| | | TURN ON | BE EF | 03 | 06 00 | 26 D7 | 01 00 | 16 20 | 01 00 |
| | Get | BE EF | 03 | 06 00 | 85 D6 | 02 00 | 16 20 | 00 00 | |
| AUTO POWER OFF | Get | BE EF | 03 | 06 00 | 08 86 | 02 00 | 10 31 | 00 00 | |
| | Increment | BE EF | 03 | 06 00 | 6E 86 | 04 00 | 10 31 | 00 00 | |
| | Decrement | BE EF | 03 | 06 00 | BF 87 | 05 00 | 10 31 | 00 00 | |

CP-S335(C9SM)/CP-X340, PJ552 (C9X)/CP-X345, PJ562 (C9XM)

| Names | Operation Type | Header | | | | Command Data | | | |
|------------------|----------------|--------|-------|-------|-------|--------------|-------|--------------|-------|
| | | | | | CRC | Action | Type | Setting Code | |
| LAMP TIME | Get | BE EF | 03 | 06 00 | C2 FF | 02 00 | 90 10 | 00 00 | |
| LAMP TIME Reset | Execute | BE EF | 03 | 06 00 | 58 DC | 06 00 | 30 70 | 00 00 | |
| FILTER TIME | Get | BE EF | 03 | 06 00 | C2 F0 | 02 00 | A0 10 | 00 00 | |
| FILER TIME Reset | Execute | BE EF | 03 | 06 00 | 98 C6 | 06 00 | 40 70 | 00 00 | |
| MAGNIFY | Get | BE EF | 03 | 06 00 | 7C D2 | 02 00 | 07 30 | 00 00 | |
| | Increment | BE EF | 03 | 06 00 | 1A D2 | 04 00 | 07 30 | 00 00 | |
| | Decrement | BE EF | 03 | 06 00 | CB D3 | 05 00 | 07 30 | 00 00 | |
| FREEZE | Set | NORMAL | BE EF | 03 | 06 00 | 83 D2 | 01 00 | 02 30 | 00 00 |
| | | FREEZE | BE EF | 03 | 06 00 | 13 D3 | 01 00 | 02 30 | 01 00 |
| | Get | BE EF | 03 | 06 00 | B0 D2 | 02 00 | 02 30 | 00 00 | |

11. Block diagram

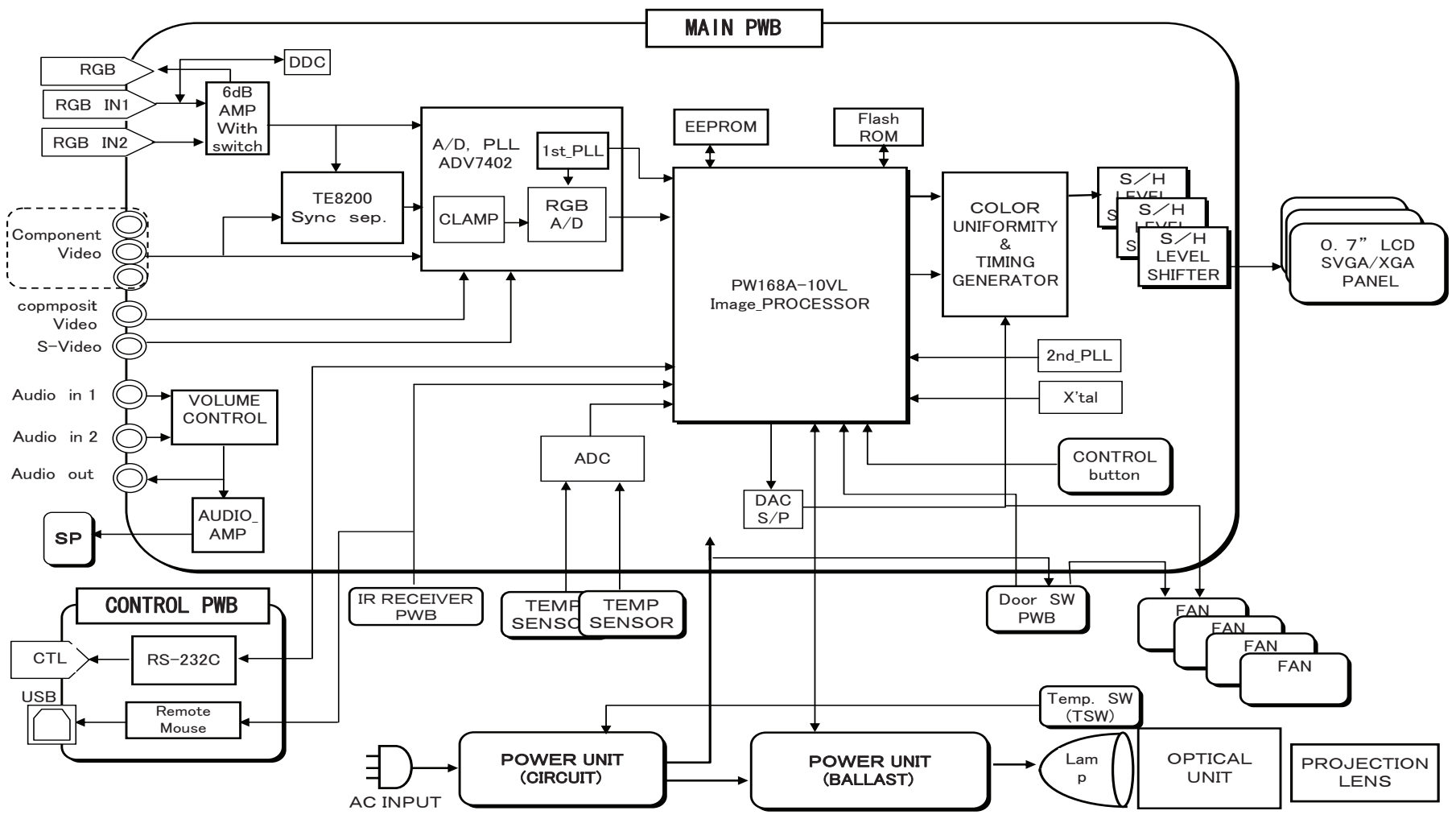

55

Block diagram (C9SM/C9X/C9XM)

12. Connector connection diagram

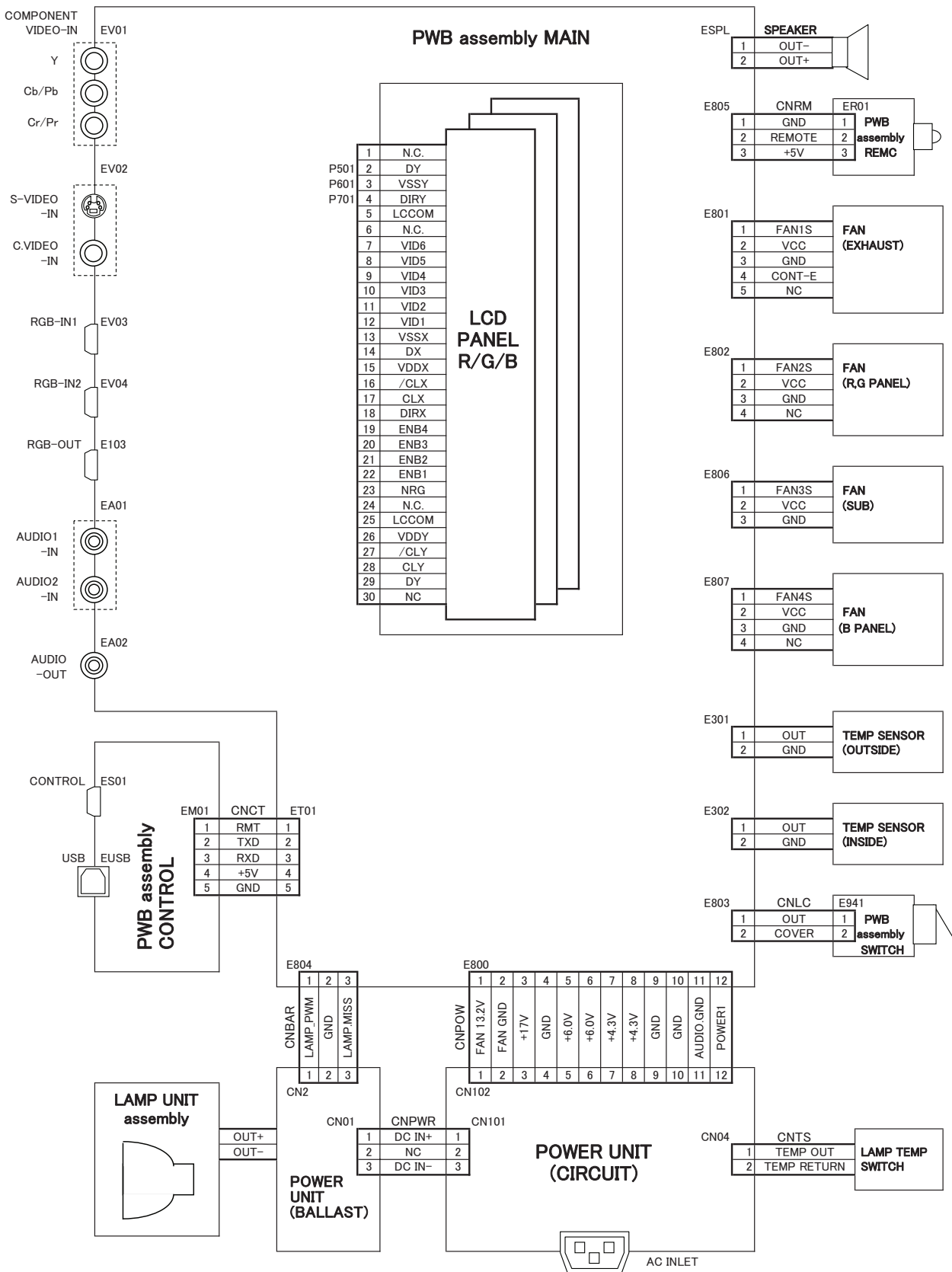

Connector connection diagram (C9SM/C9X/C9XM)

13. Basic circuit diagram

Parts with hatching are not mounted.

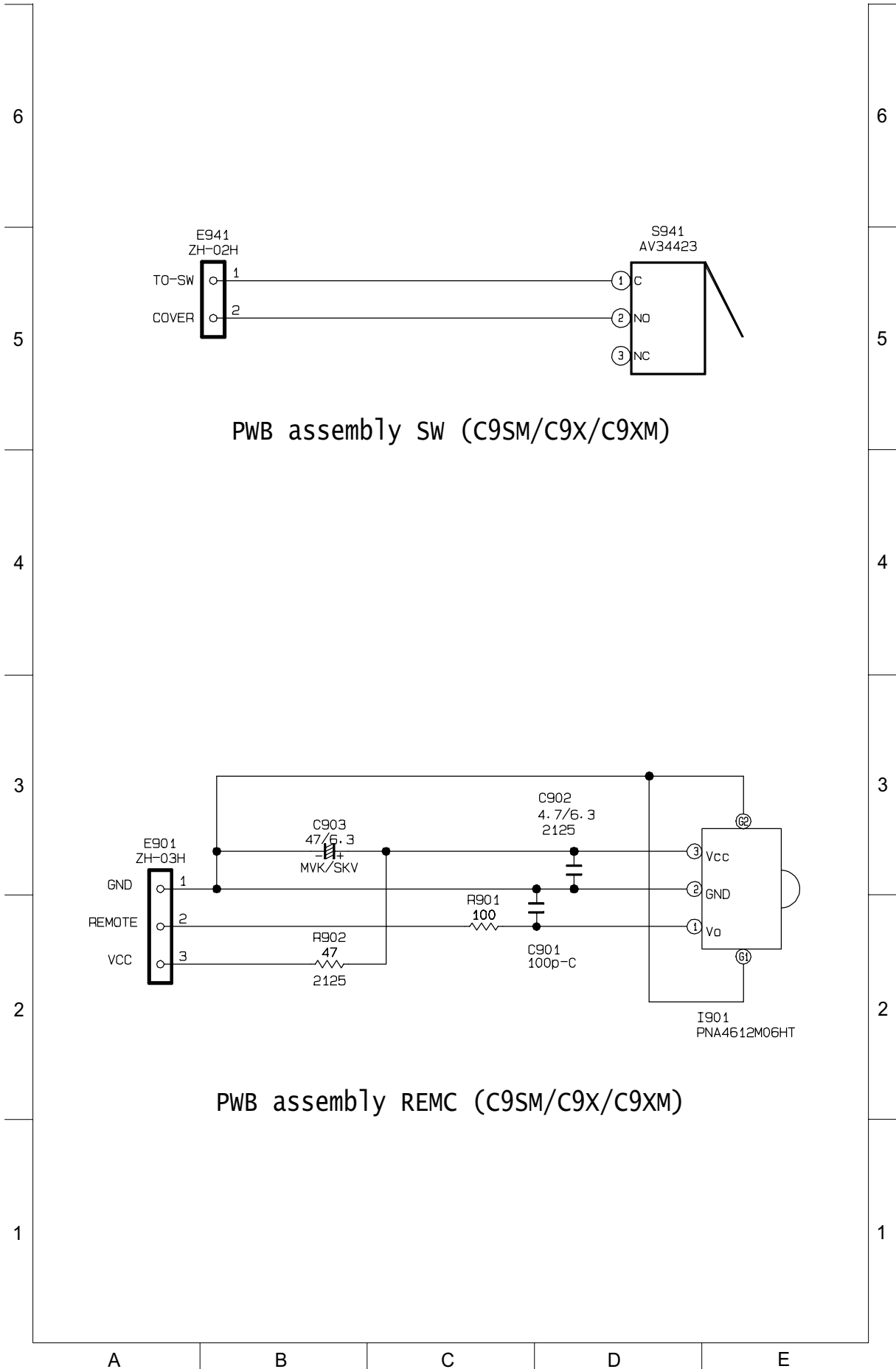

MEMO

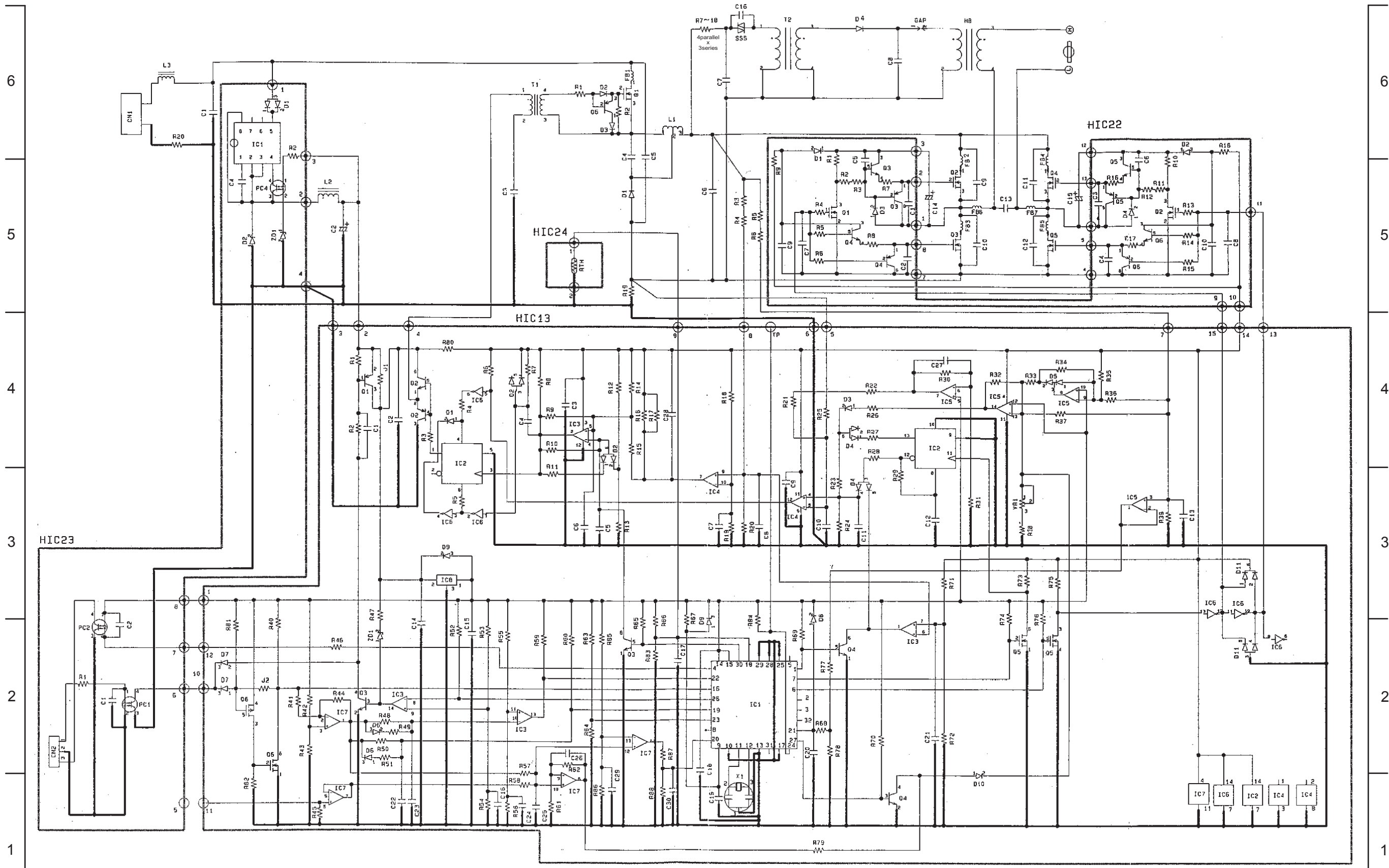

Warning
 For handling of the circuit diagram, refer to the warning on the cover.

POWER UNIT (BALLAST) (C9SM/C9X/C9XM)

A B C D E F G

6
5
4
3
2
1

6
5
4
3
2
1

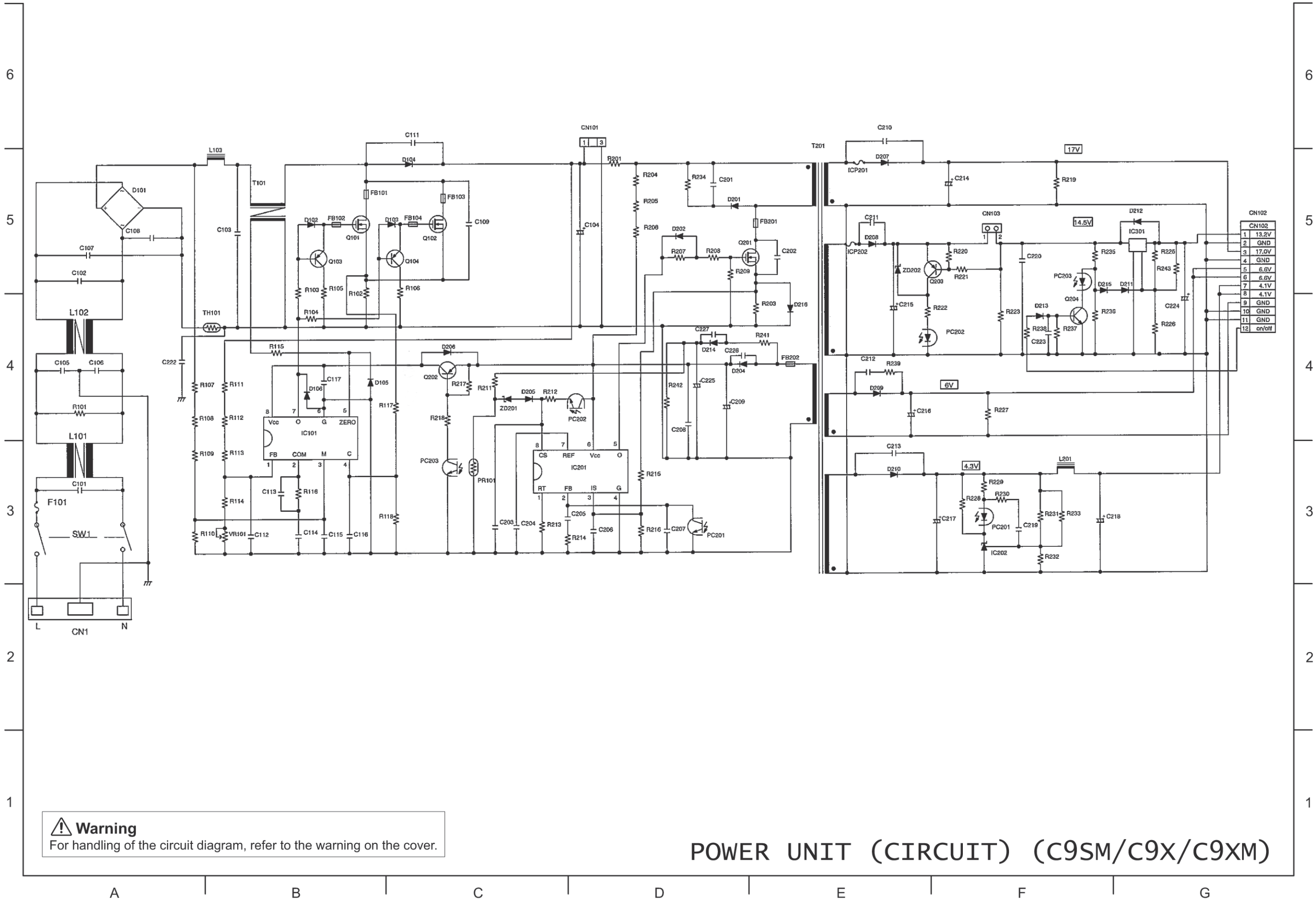

| CN102 | |
|-------|--------|
| 1 | 13.2V |
| 2 | GND |
| 3 | 17.0V |
| 4 | GND |
| 5 | 6.6V |
| 6 | 6.6V |
| 7 | 4.1V |
| 8 | 4.1V |
| 9 | GND |
| 10 | GND |
| 11 | GND |
| 12 | enVoff |

6
5
4
3
2
1

6
5
4
3
2
1

USB MOUSE

RS232C

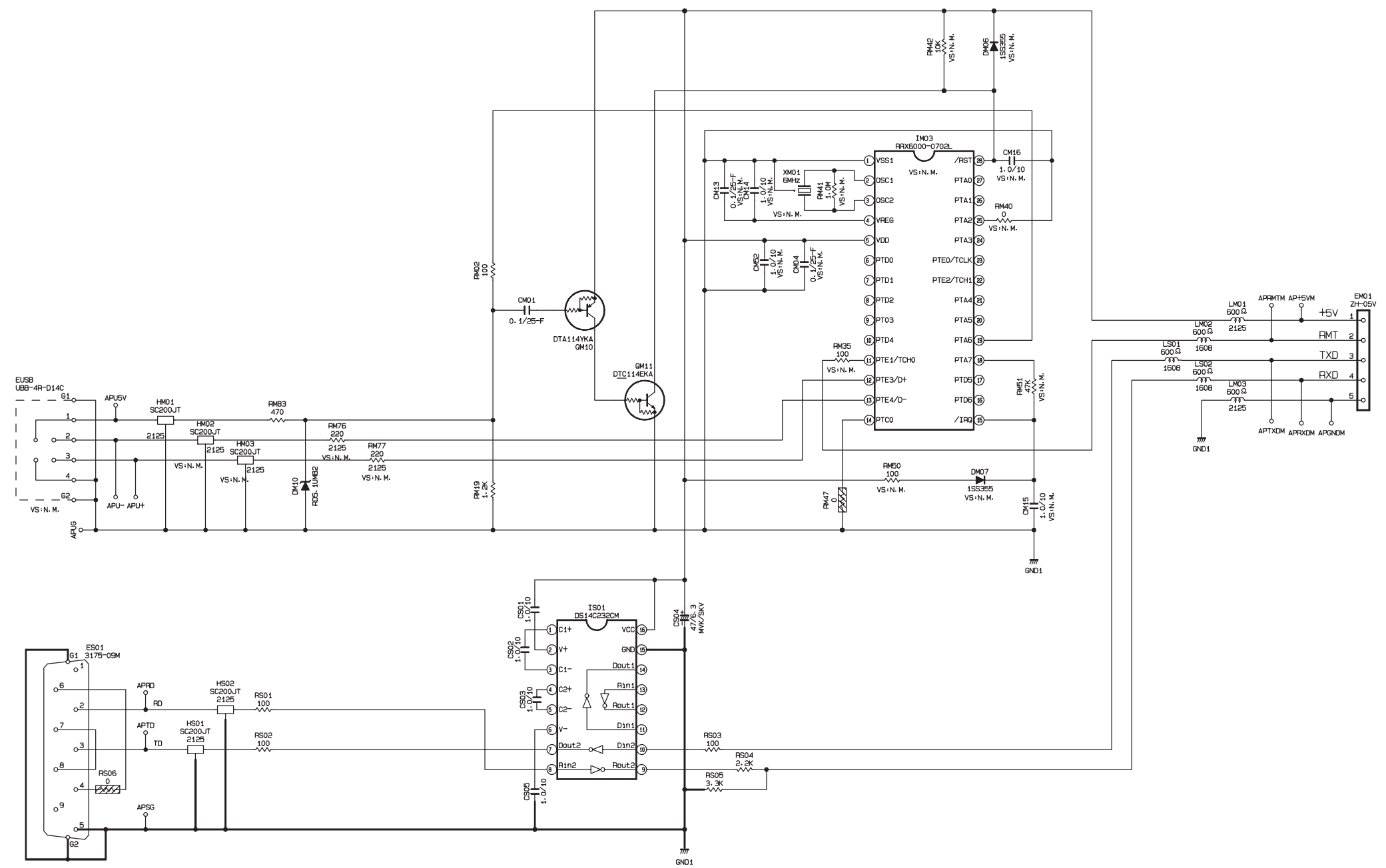

PWB assembly CONTROL (C9SM/C9X/C9XM)

A B C D E F G

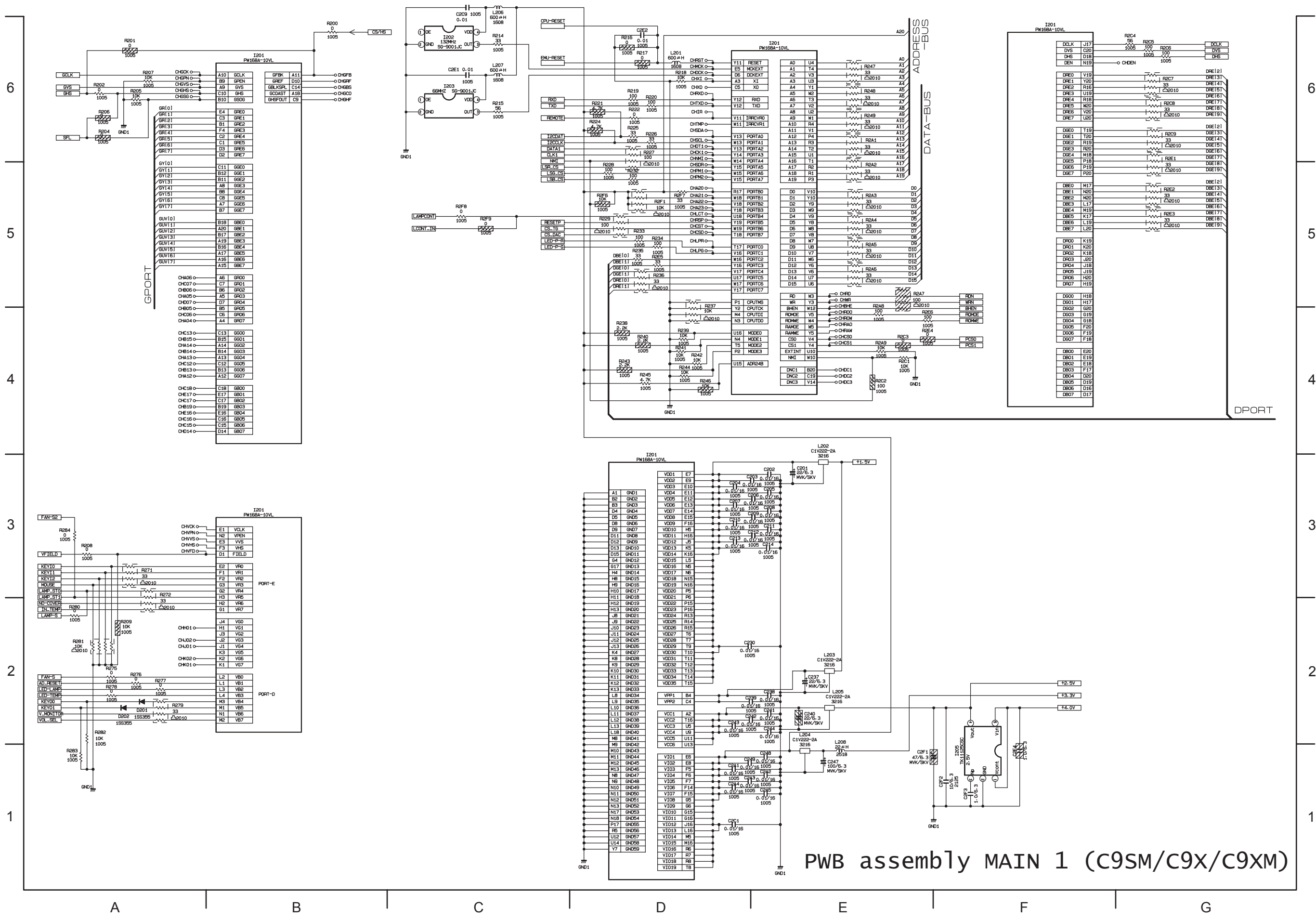

PWB assembly MAIN 1 (C9SM/C9X/C9XM)

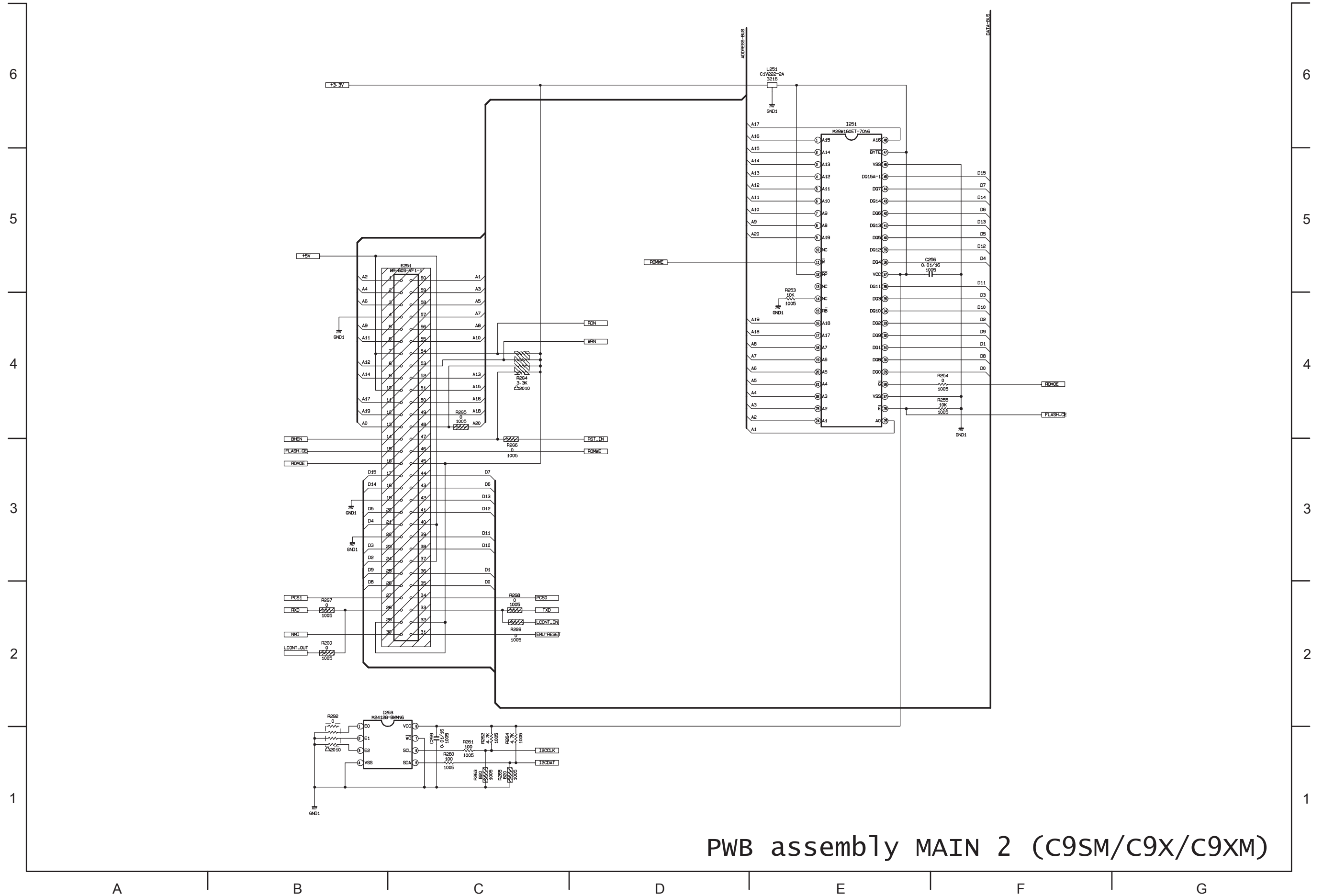

PWB assembly MAIN 2 (C9SM/C9X/C9XM)

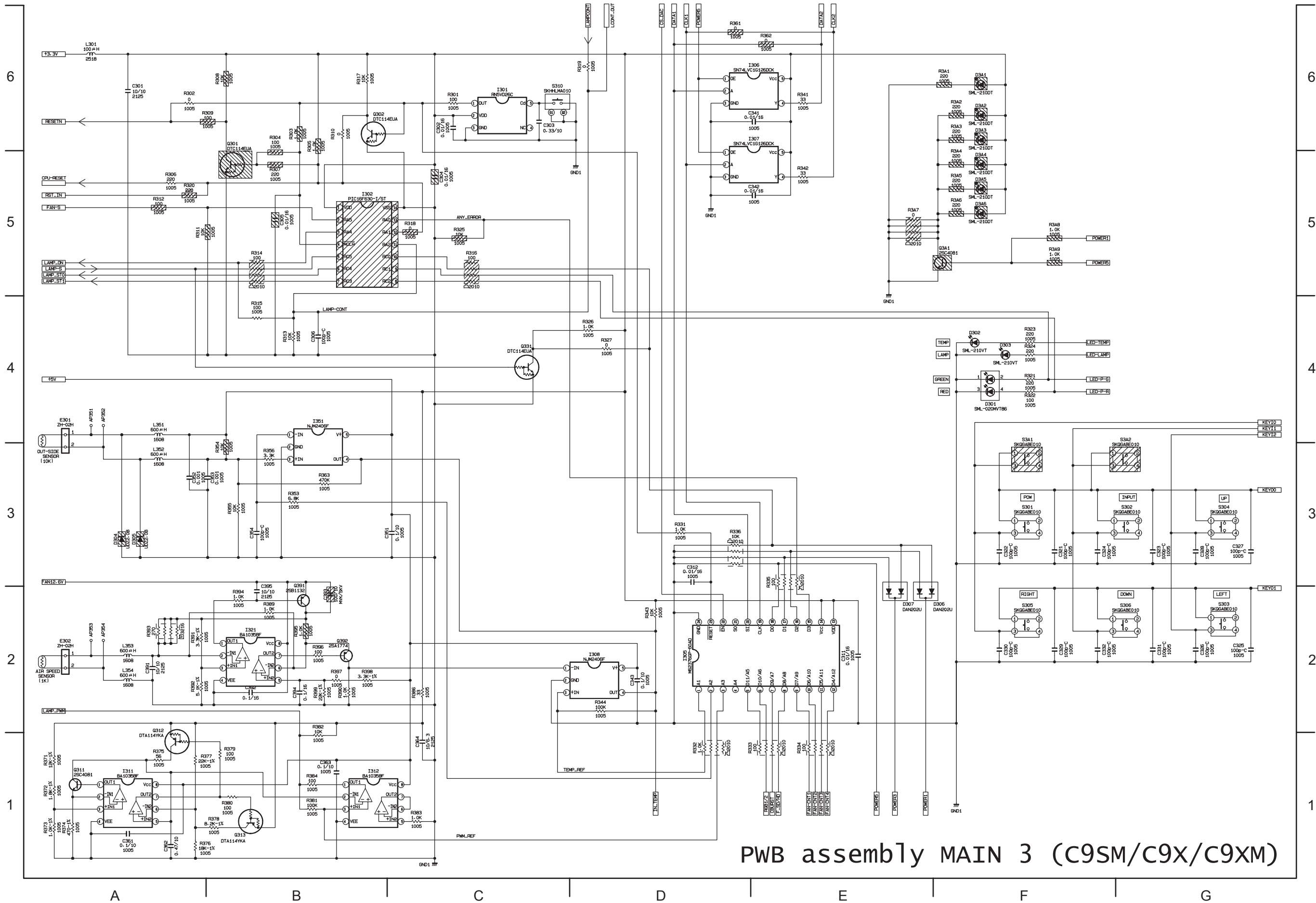

PWB assembly MAIN 3 (C9SM/C9X/C9XM)

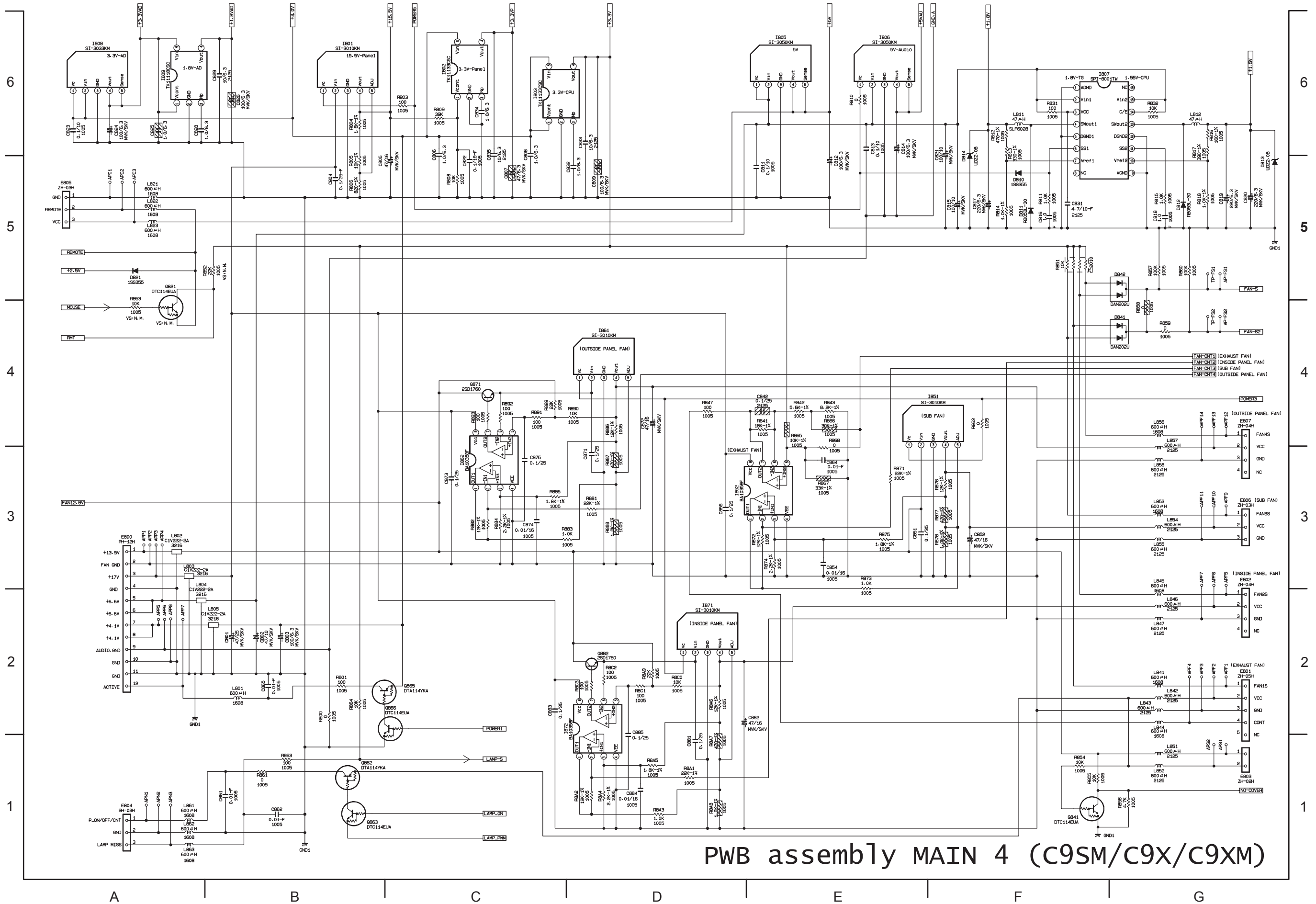

PWB assembly MAIN 4 (C9SM/C9X/C9XM)

6

5

4

3

2

1

6

5

4

3

2

1

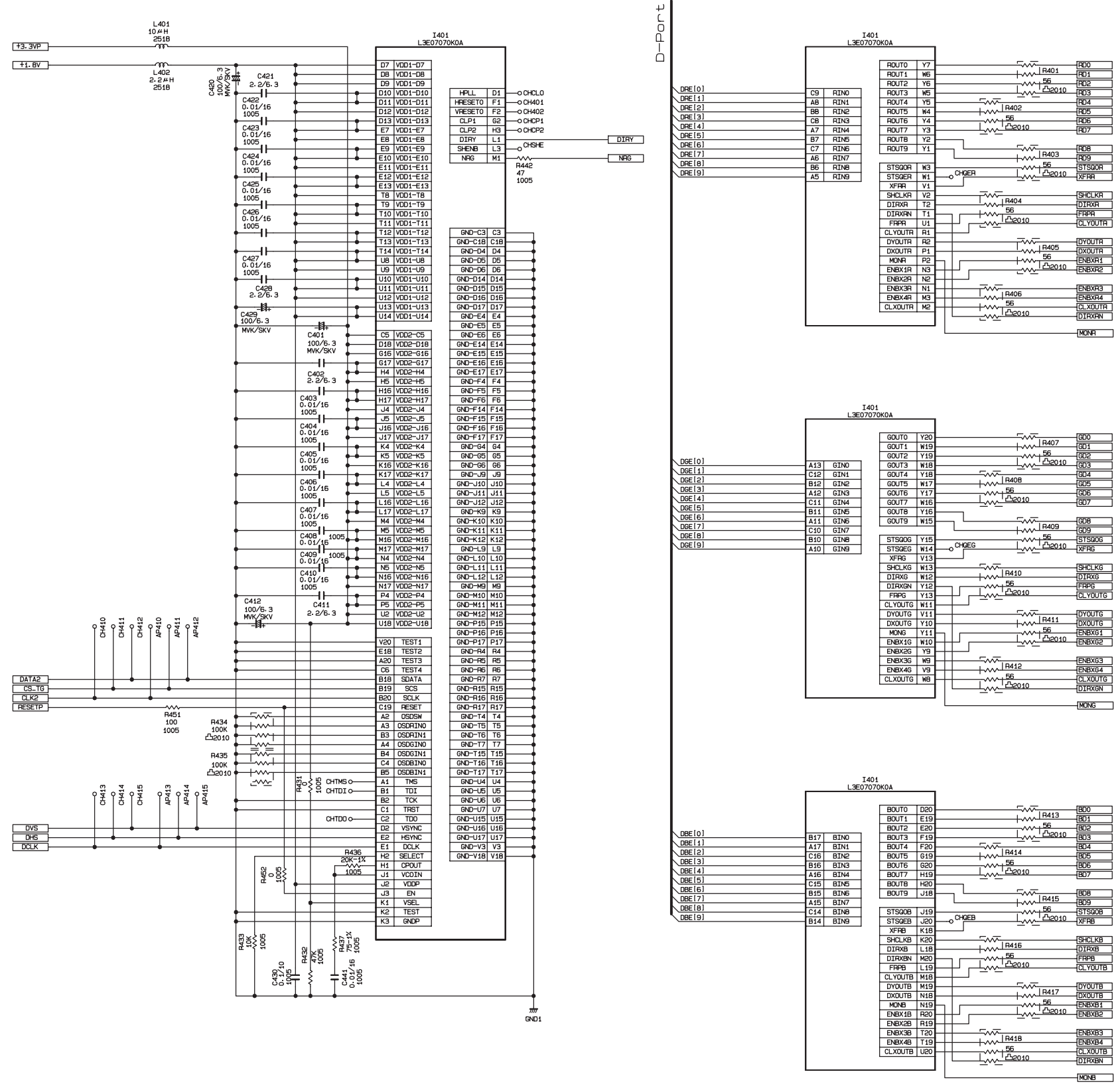

PWB assembly MAIN 5 (C9SM/C9X/C9XM)

A B C D E F G

C9 R Panel Part

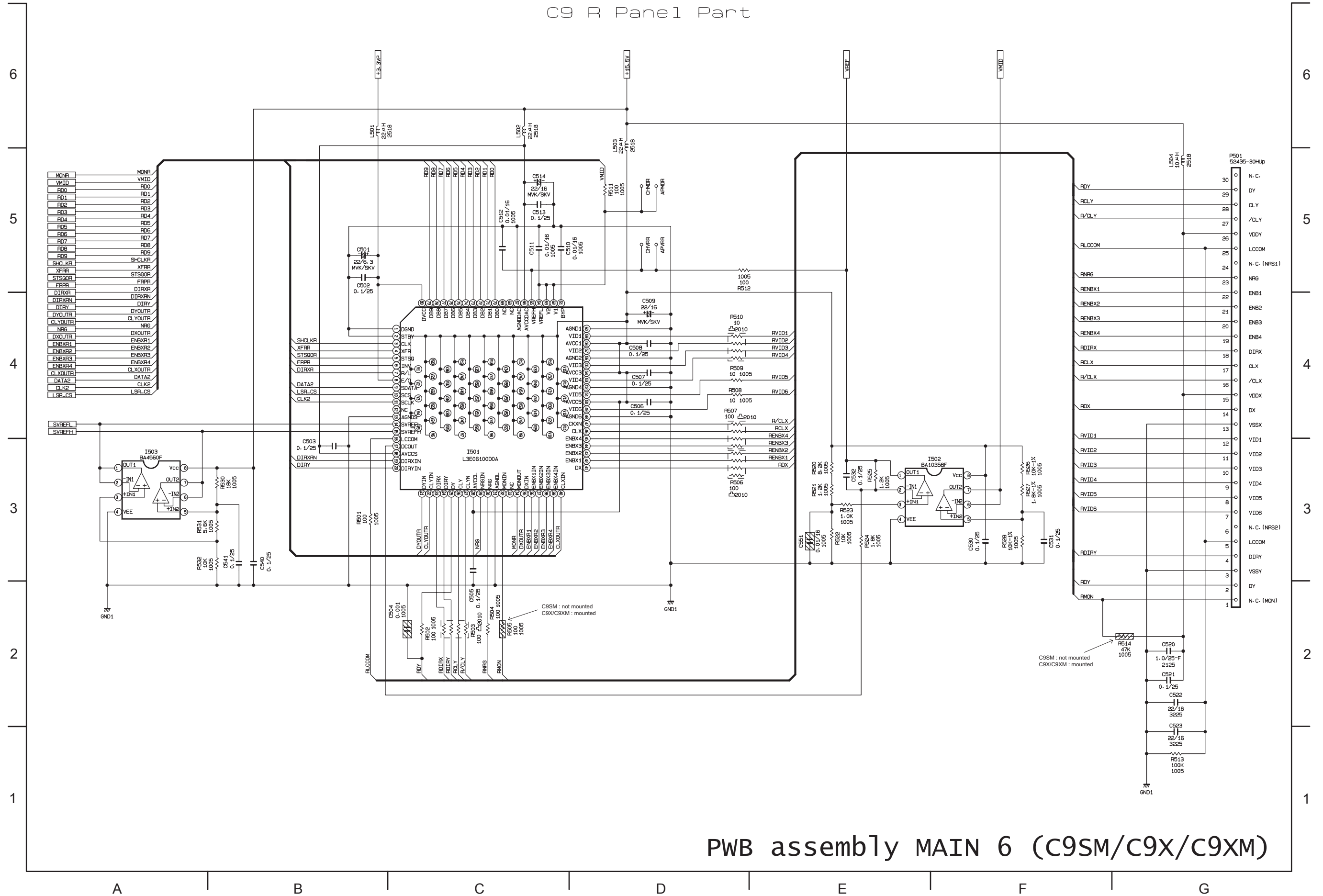

PWB assembly MAIN 6 (C9SM/C9X/C9XM)

C9 G Panel Part

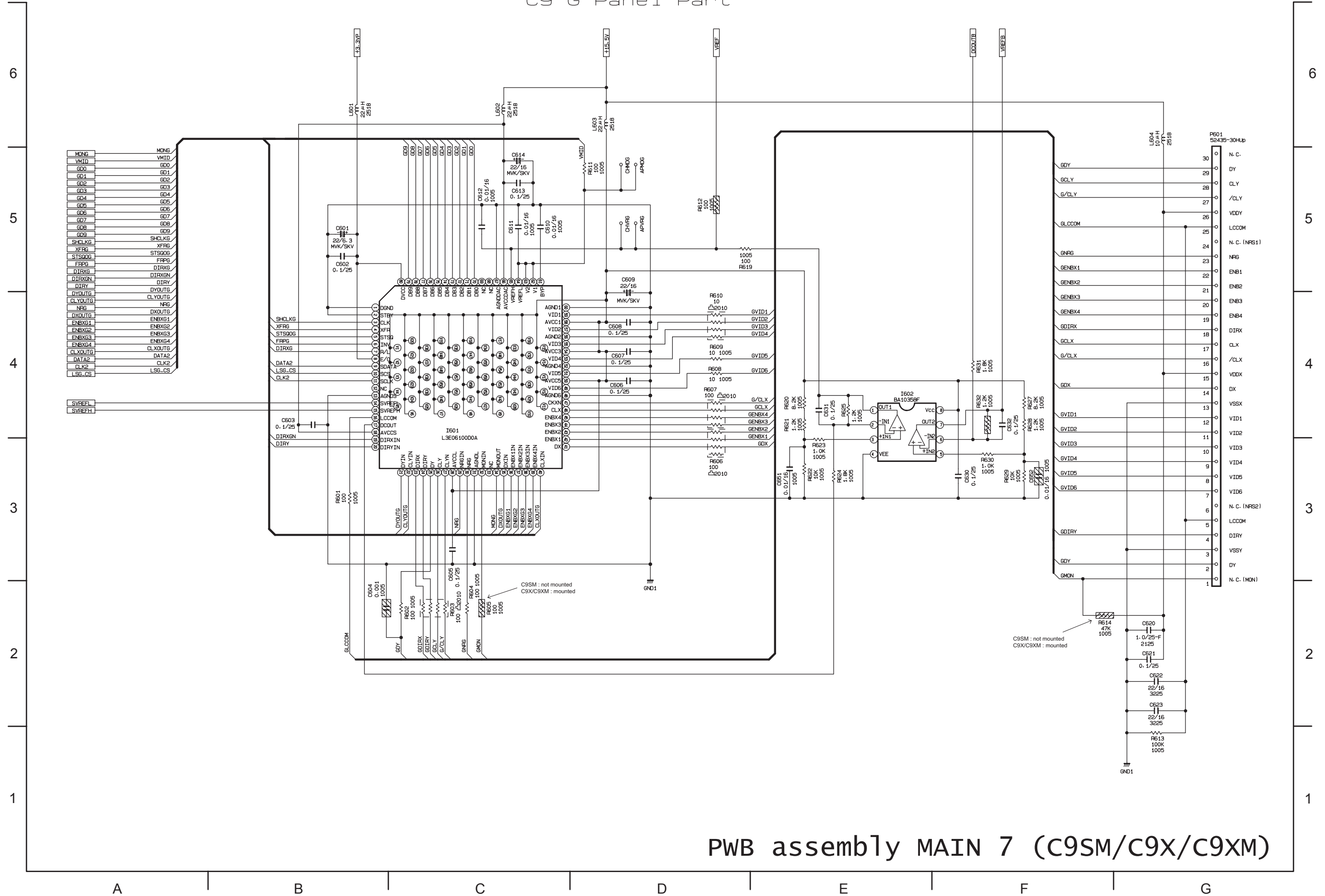

PWB assembly MAIN 7 (C9SM/C9X/C9XM)

C9 B Panel Part

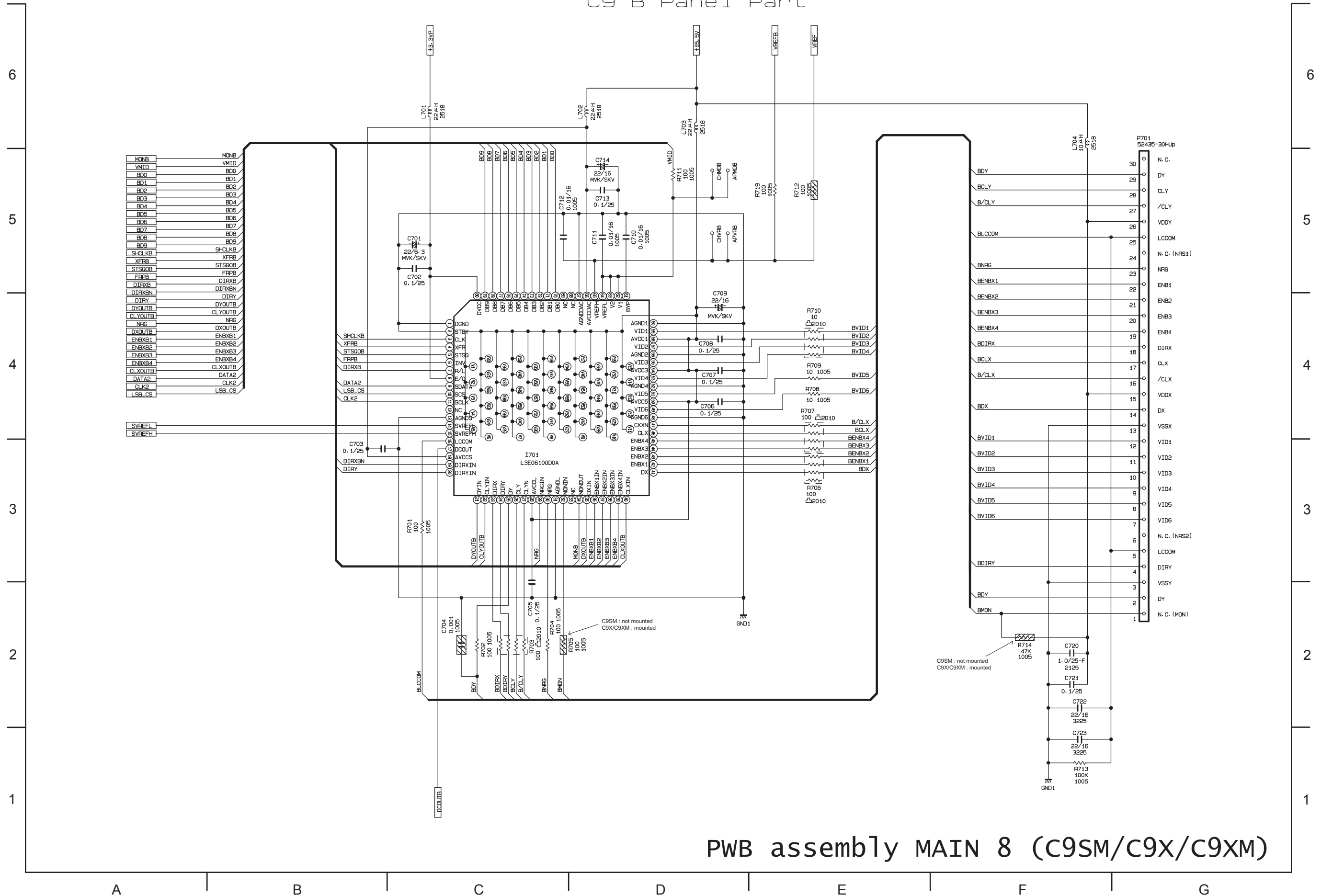

PWB assembly MAIN 8 (C9SM/C9X/C9XM)

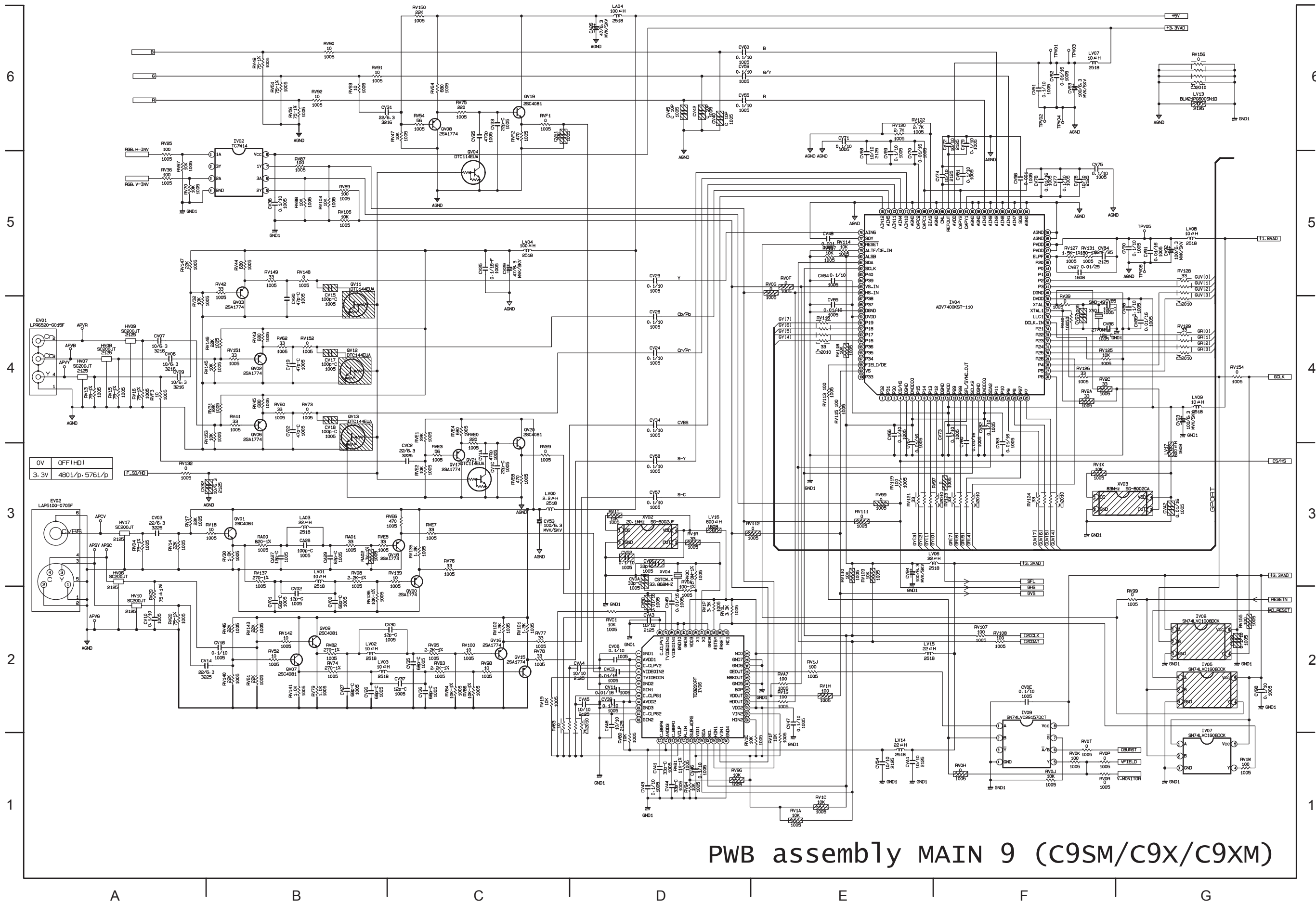

PWB assembly MAIN 9 (C9SM/C9X/C9XM)

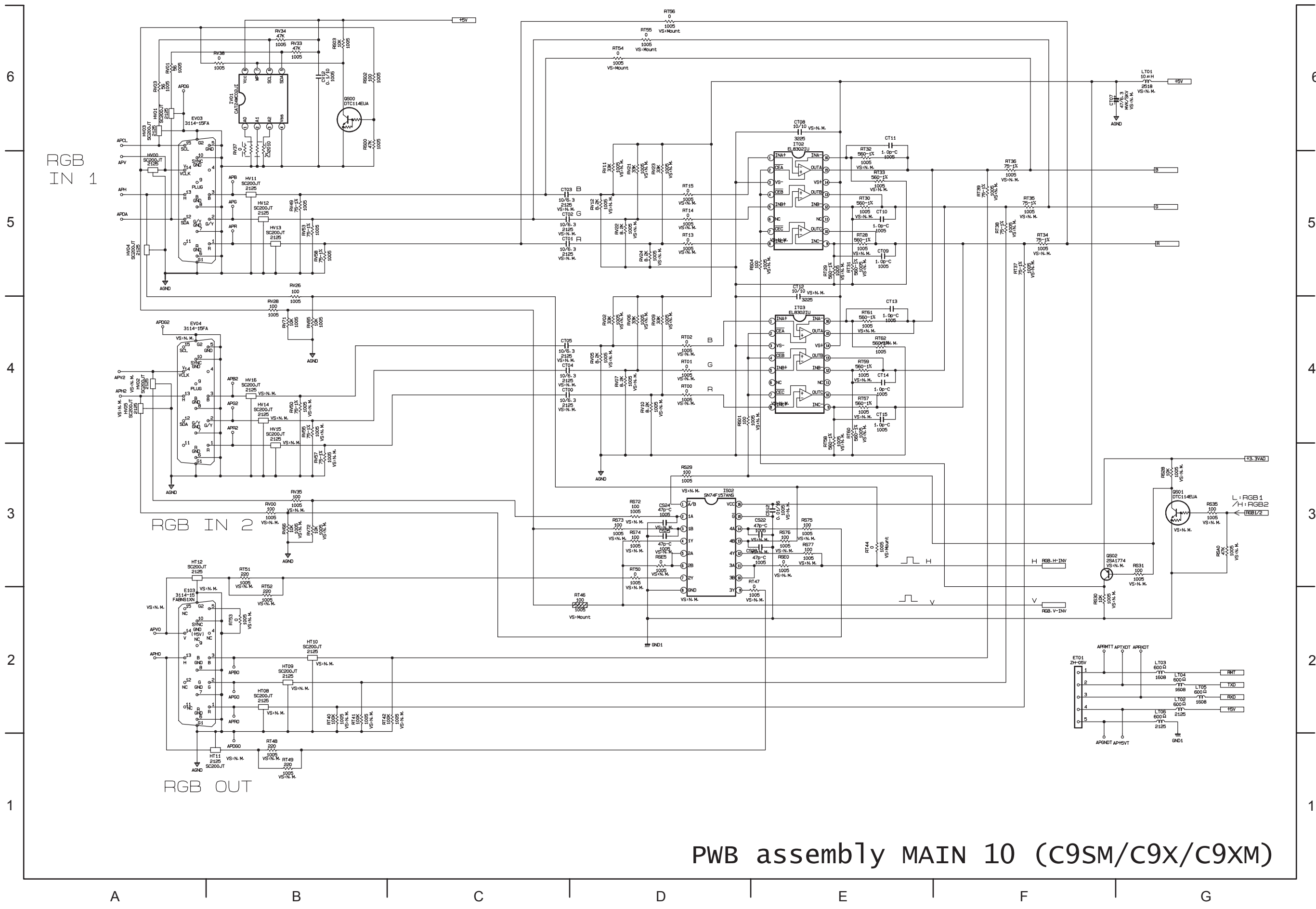

PWB assembly MAIN 10 (C9SM/C9X/C9XM)

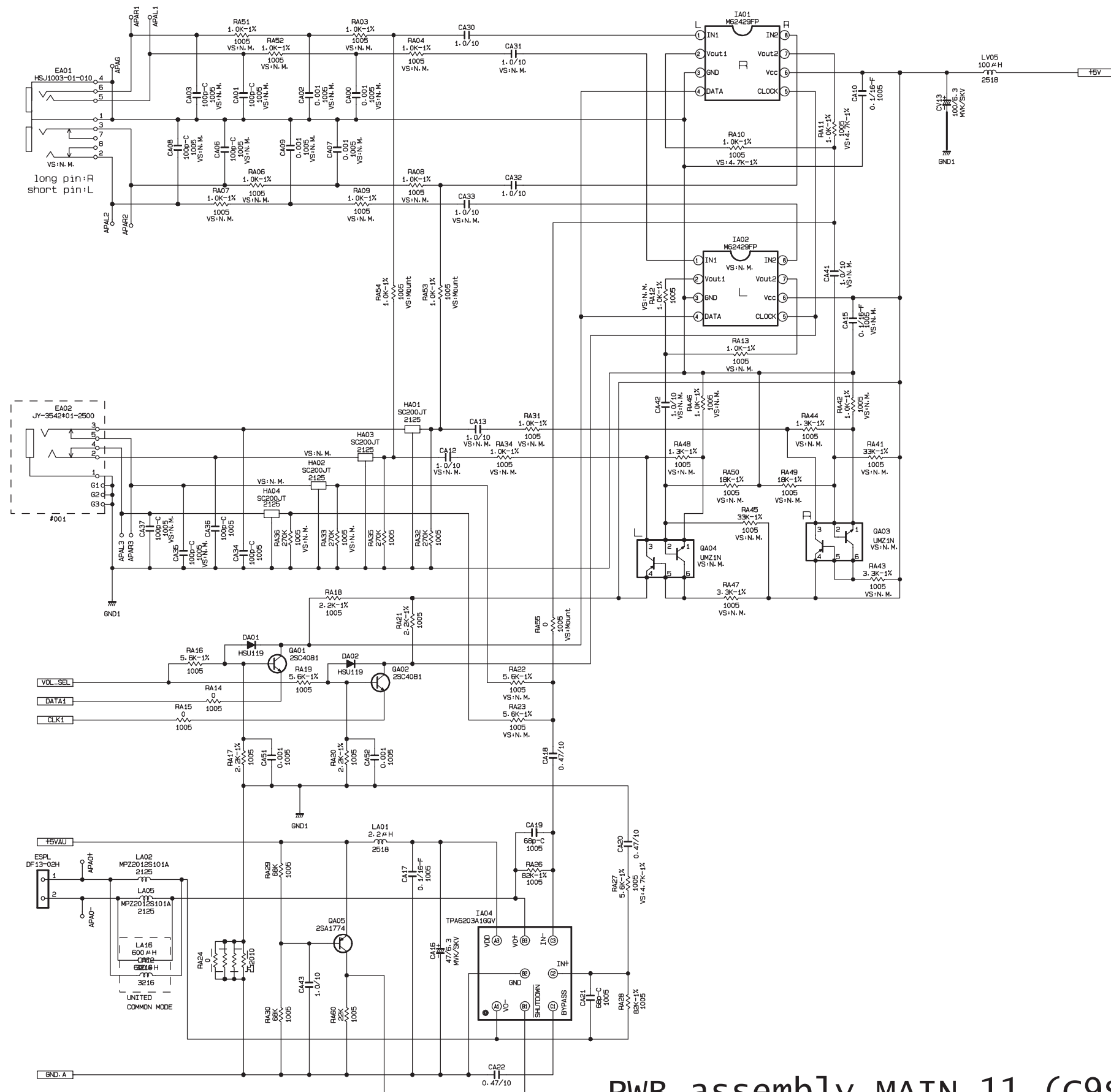

PWB assembly MAIN 11 (C9SM/C9X/C9XM)

A B C D E F G

6

5

4

3

2

1

6

5

4

3

2

1

Basic circuit diagram list

PWB assembly SW

PWB assembly REMC

POWER UNIT BALLAST

POWER UNIT CIRCUIT

PWB assembly CONTROL

PWB assembly MAIN 1

PWB assembly MAIN 2

PWB assembly MAIN 3

PWB assembly MAIN 4

PWB assembly MAIN 5

PWB assembly MAIN 6

PWB assembly MAIN 7

PWB assembly MAIN 8

PWB assembly MAIN 9

PWB assembly MAIN 10

PWB assembly MAIN 11

HITACHI

Hitachi, Ltd. Tokyo, Japan
International Sales Division
THE HITACHI ATAGO BUILDING,
No. 15-12 Nishi Shinbashi, 2 - Chome,
Minato - Ku, Tokyo 105-8430, Japan.
Tel: 03 35022111

HITACHI EUROPE LTD,

Whitebrook Park
Lower Cookham Road
Maidenhead
Berkshire
SL6 8YA

UNITED KINGDOM

Tel: 01628 643000
Fax: 01628 643400
Email: consumer-service@hitachi-eu.com

HITACHI EUROPE S.A.

364 Kifissias Ave. & 1, Delfon Str.
152 33 Chalandri
Athens

GREECE

Tel: 1-6837200
Fax: 1-6835964
Email: service.hellas@hitachi-eu.com

HITACHI EUROPE GmbH

Munich Office
Dornacher Strasse 3
D-85622 Feldkirchen bei München

GERMANY

Tel: +49-89-991 80-0
Fax: +49-89-991 80-224
Hotline: +49-180-551 25 51 (12ct/min)
Email: HSE-DUS.service@hitachi-eu.com

HITACHI EUROPE S.A.

Gran Via Carlos III, 86, planta 5
Edificios Trade - Torre Este
08028 Barcelona

SPAIN

Tel: +34 93 409 2550
Fax: +34 93 491 3513
Email: atencion.cliente@hitachi-eu.com

HITACHI EUROPE srl

Via Tommaso Gulli N.39, 20147
Milano, Italia

ITALY

Tel: +39 02 487861
Tel: +39 02 38073415 Servizio Clienti
Fax: +39 02 48786381/2
Email: customerservice.italy@hitachi-eu.com

HITACHI Europe AB

Box 77 S-164 94 Kista

SWEDEN

Tel: +46 (0) 8 562 711 00
Fax: +46 (0) 8 562 711 13
Email: csgswe@hitachi-eu.com

HITACHI EUROPE S.A.S

Lyon Office
B.P. 45, 69671 BRON CEDEX

FRANCE

Tel: +33 04 72 14 29 70
Fax: +33 04 72 14 29 99
Email: france.consommateur@hitachi-eu.com

HITACHI EUROPE LTD (Norway) AB

STRANDVEIEN 18

1366 Lysaker

NORWAY

Tel: 67 5190 30
Fax: 67 5190 32
Email: csgnor@hitachi-eu.com

HITACH EUROPE AB

Egebækgård
Egebækvej 98
DK-2850 Nærum

DENMARK

Tel: +45 43 43 6050
Fax: +45 43 60 51
Email: csgnor@hitachi-eu.com

HITACHI EUROPE AB

Neopoli / Niemenkatu 73
FIN-15140 Lahti

FINLAND

Tel : +358 3 8858 271
Fax: +358 3 8858 272
Email: csgnor@hitachi-eu.com

Hitachi Europe Ltd

Bergensesteenweg 421
1600 Sint-Pieters-Leeuw

BELGIUM

Tel: +32 2 363 99 01
Fax: +32 2 363 99 00
Email: sofie.van.bom@hitachi-eu.com

HITACHI EUROPE LTD

Na Sychrove 975/8
101 27 Praha 10 - Bohdalec

CZECH REPUBLIC

Tel: +420 267 212 383
Fax: +420 267 212 385
Email: csgnor@hitachi-eu.com

Free Manuals Download Website

<http://myh66.com>

<http://usermanuals.us>

<http://www.somanuals.com>

<http://www.4manuals.cc>

<http://www.manual-lib.com>

<http://www.404manual.com>

<http://www.luxmanual.com>

<http://aubethermostatmanual.com>

Golf course search by state

<http://golfingnear.com>

Email search by domain

<http://emailbydomain.com>

Auto manuals search

<http://auto.somanuals.com>

TV manuals search

<http://tv.somanuals.com>