

HITACHI

SERVICE MANUAL

SM0524

**CPS317(C3S3)
CPX327(C3XM3)
EDS3170(C3S3)
EDX3270(C3XM3)
EDS3170A(C3S3E)
EDX3270A(C3XM3)
ED-X3250AT(C3X3ET)
EDX3280AT(C3XM4ET)**

Warning

The technical information and parts shown in this manual are not to be used for: the development, design, production, storage or use of nuclear, chemical, biological or missile weapons or other weapons of mass destruction; or military purposes; or purposes that endanger global safety and peace. Moreover, do not sell, give, or export these items, or grant permission for use to parties with such objectives. Forward all inquiries to Hitachi Ltd.

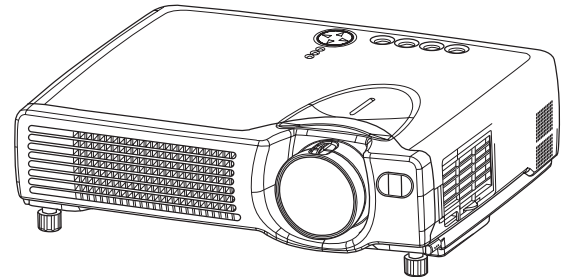

Caution

Be sure to read this manual before servicing. To assure safety from fire, electric shock, injury, harmful radiation and materials, various measures are provided in this Hitachi Multimedia LCD Projector. Be sure to read cautionary items described in the manual to maintain safety before servicing.

Service Warning

1. When replacing the lamp, avoid burns to your fingers. The lamp becomes very hot.
2. Never touch the lamp bulb with a finger or anything else. Never drop it or give it a shock. They may cause bursting of the bulb.
3. This projector is provided with a high voltage circuit for the lamp. Do not touch the electric parts of power unit (main), when turning on the projector.
4. Do not touch the exhaust fan, during operation.
5. The LCD module assembly is likely to be damaged. If replacing the LCD module assembly, do not hold the FPC of the LCD module assembly.
6. Use the cables which are included with the projector or specified

Contents

| | | | |
|-----------------------|----|---------------------------------|----|
| 1. Features | 2 | 8. Connector connection diagram | 32 |
| 2. Specifications | 2 | 9. Wiring diagram | 34 |
| 3. Names of each part | 5 | 10. Basic circuit diagrams | 40 |
| 4. Adjustment | 7 | 11. Disassembly diagram | 59 |
| 5. Troubleshooting | 13 | 12. Replacement parts list | 61 |
| 6. Service points | 18 | 13. RS-232C communication | 64 |
| 7. Block diagram | 30 | | |

SPECIFICATIONS AND PARTS ARE SUBJECT TO CHANGE FOR IMPROVEMENT.

Multimedia LCD Projector

January 2003 Digital Media Division

CPS317, EDS3170, EDS3170A, CPX327, EDX3270, EDX3270A

1. Features

- ▶ 1,500 ANSI lumens, 2.7kg(6lbs)
- ▶ Full connectivity
- ▶ Easy and flexible keystone adjustment
- ▶ My screen
- ▶ Wide angle lens
- ▶ Low noise

2. Specifications

| | | CPS317/EDS3170 /EDS3170A | CPX327/EDX3270/EDX3270A |
|----------------------|------------------|---|--|
| Liquid crystal panel | Drive system | TFT active matrix | |
| | Panel size | 0.7 inches | |
| | Number of pixels | 800 (H) × 600 (V) | 1024 (H) × 768 (V) |
| Lamp | | 150W UHB | |
| Video input | System | NTSC, PAL(BGDHI), SECAM, PAL-M, PAL-N, NTSC4.43, PAL60 | |
| | Level | Composite | 1.0±0.1Vp-p (75Ω termination) |
| | | S-video | Y : 1.0±0.1Vp-p (75Ω termination) C : 0.286±0.1Vp-p (NTSC burst signal, 75Ω termination) 0.3±0.1Vp-p (PAL/SECAM burst signal, 75Ω termination) |
| | | Component | Y : 1.0±0.1Vp-p (75Ω termination) Cb/CR : 0.7±0.1Vp-p (75Ω termination) Pb/Pr : 0.7±0.1Vp-p (75Ω termination) |
| RGB input / output | Analog RGB | 0.7Vp-p (75Ω termination) | |
| | Sync. | TTL level | |
| Audio | Input | 200mVrms, 47kΩ | |
| | Output | 200mVrms, output impedance 1kΩ | |
| Speaker output | | 1.0W (mono) | |
| Power supply | | AC100~120V/2.7A, AC220~240V/1.3A | |
| Power consumption | | 240W | |
| Dimensions | | 295 (W) × 87.5 (H) × 231 (D) mm | |
| Weight | | 2.74kg (6.04lbs) | |
| Temperature range | | Operation : 0~35°C Storage : -20~60°C | |
| Accessories | | Remote control transmitter × 1 RGB cable × 1 Video/Audio cable × 1 USB cable × 1 | POWER cord × 3 Battery × 2 Carrying bag × 1 (CP Models Only) User's manual (with Safety Instructions) × 1 |

EDX3280AT, EDX3250AT

Features

2,000 ANSI lumens, 2.7kg(6lbs) EDX3280AT, (1,200 lumens, 2.7kg(6lbs) EDX3250AT)

Specification

| | | EDX3280AT/EDX3250AT |
|----------------------|------------------|--|
| Liquid crystal panel | Drive system | TFT active matrix |
| | Panel size | 0.7 inches |
| | Number of pixels | 1024 (H) × 768 (V) |
| Lamp | | 150W UHB |
| Video input | System | NTSC, PAL(BGDHI), SECAM, PAL-M, PAL-N, NTSC4.43, PAL60 |
| | Level | Composite 1.0 ±0.1Vp-p (75 Ω termination) |
| | | S-video Y : 1.0 ±0.1Vp-p (75 Ω termination) C : 0.286 ±0.1Vp-p (NTSC burst signal, 75 Ω termination) 0.3 ±0.1Vp-p (PAL/SECAM burst signal, 75 Ω termination) |
| RGB input / output | Analog RGB | 0.7Vp-p (75 Ω termination) |
| | Sync. | TTL level |
| Audio | Input | 200mVrms, 47kΩ |
| | Output | 200mVrms, output impedance 1kΩ |
| Speaker output | | 1.0W (mono) |
| Power supply | | AC100~120V/2.7A, AC220~240V/1.3A |
| Power consumption | | 240W |
| Dimensions | | 295 (W) × 87.5 (H) × 231 (D) mm |
| Weight | | 2.74kg (6.04lbs) |
| Temperature range | | Operation : 0~35°C Storage : -20~60°C |
| Accessories | | Remote control transmitter × 1 POWER cord × 3 RGB cable × 1 Battery × 2 Video/Audio cable × 1 User's manual (with Safety Instructions) × 1 USB cable × 1 |

EDX3280AT

Difference with the conventional model

The base model of EDX3280AT is EDX3270A. The liquid crystal panel is the main change from EDX3270A. The main differences with the base model are described in the following table.

● The main differences with the conventional model

| No. | Contents | Difference | | Note |
|-----|----------------|--|---|--------------------|
| | | ED-X3270A | ED-X3280AT | |
| 1 | Features | Brightness 1,500 ANSI lumens (A catalog may have 1,700 ANSI lumens) | Brightness 2,000 ANSI lumens | Please see 2 page. |
| 2 | Specifications | Accessories: Power cord x 1 | Accessories: Power cord x 3 | Please see 2 page. |
| 3 | Parts list | Option Lamp: DT00521(ED-X3270A) Others | Option Lamp: DT00511(ED-X3280AT) Others | Please see 4 page. |

Only difference is described. Please refer to a ED-X3270A service guide except the above-mentioned difference.

● Lamp (Option Lamp: DT00511(ED-X3280A))

| | |
|---|--|
|  | HIGH VOLTAGE HIGH TEMPERATURE HIGH PRESSURE |
| <p>Before replacing the lamp, check the serial number of the replacement lamp bulb (sold separately: DT-00511 for ED-X3280), then contact your local dealer. Before replacing the lamp, turn off the power, and unplug the power cord, then wait at least 45 minutes, in order to ensure that the lamp is properly cooled. Removing the lamp bulb while it is still hot could cause burns, or cause the lamp bulb to burst.</p> | |

Difference with the conventional model

The base model of ED-X3250AT is ED-X3270A. The liquid crystal panel is mainly changed from ED-X3270A. The main differences with the base model are described in the following table.

● The main differences with the conventional model

| No. | Contents | Difference | | Note |
|-----|----------------|--|--|------|
| | | ED-X3270A | ED-X3250AT | |
| 1 | Features | Brightness 1,500 ANSI lumens (A catalog may have 1,700 ANSI lumens) | Brightness 1,200 ANSI lumens | |
| 2 | Specifications | Accessories: Power cord × 1 | Accessories: Power cord × 2 | |
| 3 | Parts list | LCD/LENS PRISM ASS'Y: UX09286 Others | LCD/LENS PRISM ASS'Y: UX09287 Others | |

Only difference is described. Please refer to a ED-X3270A service guide except the above-mentioned difference.

● Lamp (Option Lamp: DT00521(ED-X3250AT))

| | |
|---|---|
|  | <p>HIGH VOLTAGE HIGH TEMPERATURE HIGH PRESSURE</p> |
| <p>Before replacing the lamp, check the serial number of the replacement lamp bulb (sold separately: DT-00521 for ED-X3250AT), then contact your local dealer. Before replacing the lamp, turn off the power, and unplug the power cord, then wait at least 45 minutes, in order to ensure that the lamp is properly cooled. Removing the lamp bulb while it is still hot could cause burns, or cause the lamp bulb to burst.</p> | |

3. Names of each part

● Parts names

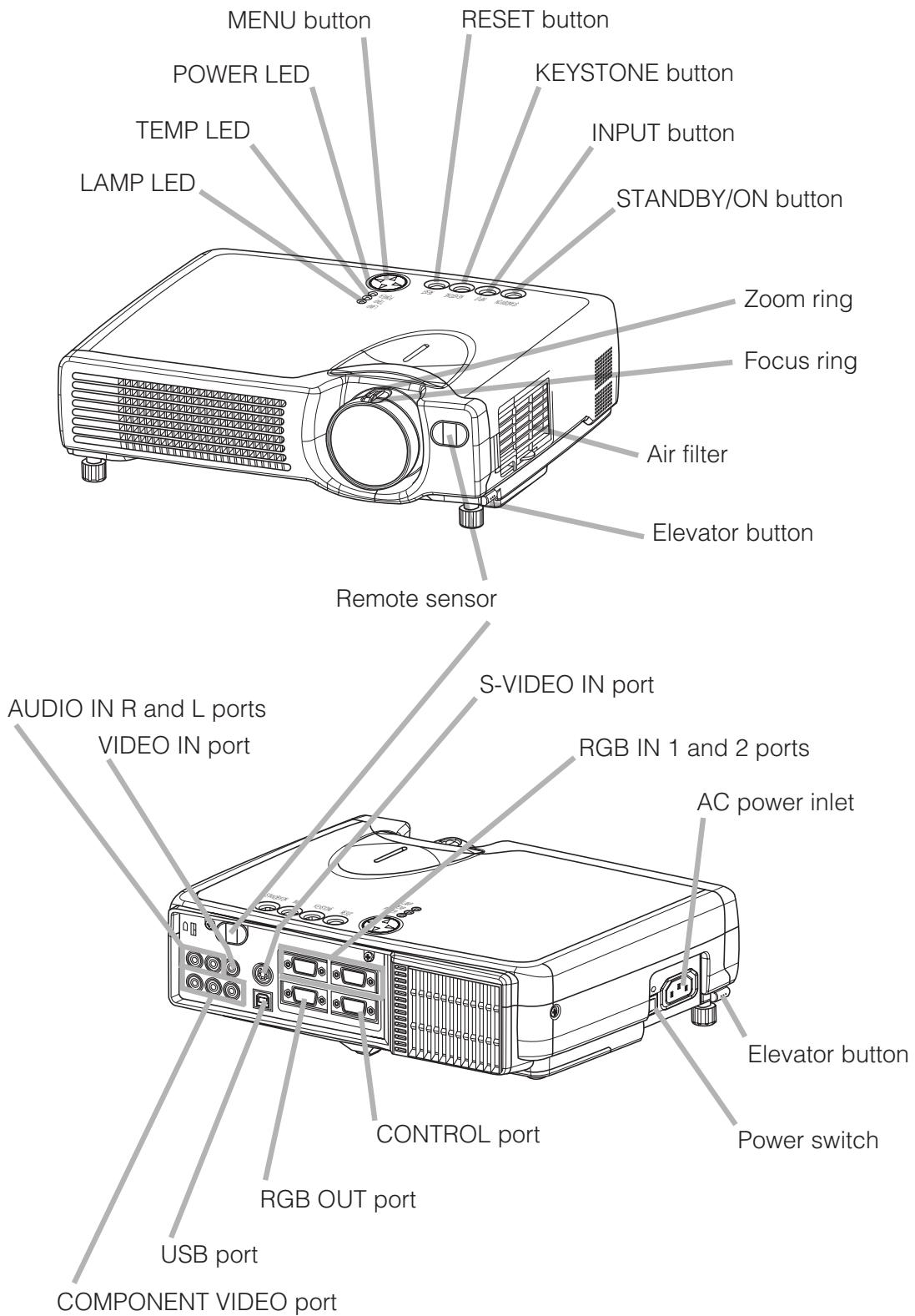

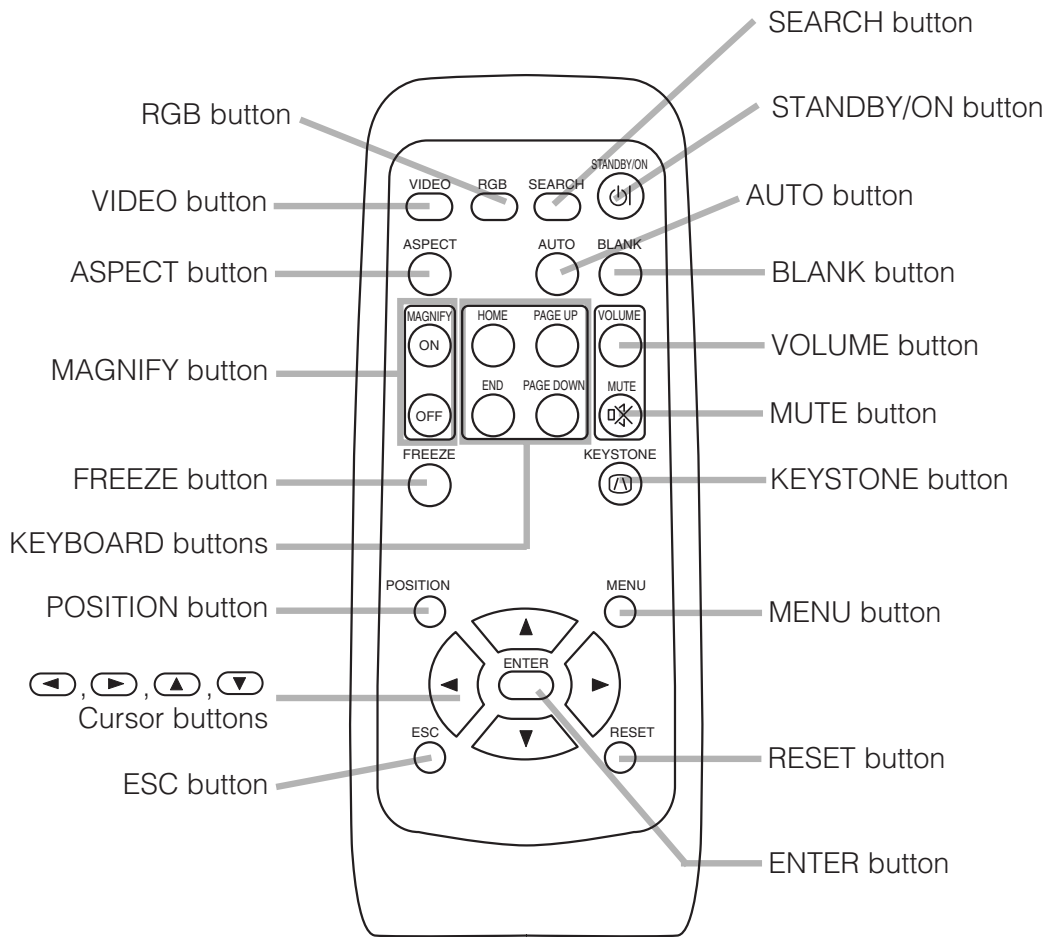

Remote control transmitter

4. Adjustment

4-1 Before adjusting

4-1-1 Selection of adjustment

When any parts in the table 4-1 are changed, choose the proffer adjusting items with the chart.

Table 4-1: Relation between the replaced part and adjustment

| Replaced part | Adjustment | | | | |
|-------------------------|------------------|--------------------|----------------------|--------------------------|-----------------------------|
| | Ghost (Chap.4-2) | Flicker (Chap.4-3) | PSIG/NRSH (Chap.4-4) | White balance (Chap.4-5) | Color uniformity (Chap.4-6) |
| Dichroic optics unit | ○ | ○ | × | △ | △ |
| LCD/LENS prism assembly | ○ | ○ | ○ | ○ | ○ |
| PWB assembly drive | ○ | ○ | ○ | ○ | ○ |
| Lamp unit assembly | △ | △ | × | △ | △ |

○: means need for adjustment. ×: means not need for adjustment.
△: means recommended.

4-1-2 Setting of condition before adjustment

1. Before starting adjustment, warm up the projector for about 10 minutes.(Blank white)
2. Set Zoom Wide to Max. And project an image with more than 40 inches in diagonal size.
3. Normalizing the video adjustment.
(Press the [MENU] button of the Remote control transmitter to display the MAIN menu, and then press the [RESET] button. And select the [DEFAULT]. Next, open MAIN menu and press the [▼] key to display the PICTURE1 menu, then press the [RESET] key to set to [DEFAULT].)

*note :The MAIN and PICTURE1 menu is not reset with no signal.

4. Set the normal at OPT-WHISPER in the menu.
5. Reset KEYSTONE correction.
6. Perform all adjustments from the Adjustment menu.
Perform the following operations to display the Adjustment menu.
 - a. Press the [MENU] button of the Remote control transmitter (the Setup menu will appear).
 - b. Next, press the [RESET] button one time. And press the [RESET] button again for 5 seconds or more (the Adjustment menu will appear).

4-2 Ghost adjustment

Signals for internal adjustment

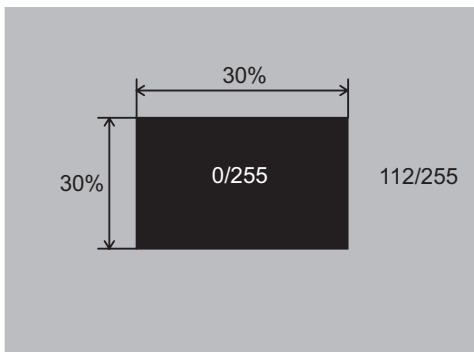

Adjustment procedure

1. Use DAC-P - GHOST - R: in the Adjustment menu to adjust so that R color ghost is at a minimum.
(Set the adjustment value to default, and then raise the value. When a ghost appears to the left of a vertical line, reduce the value by 2 steps. :CPS317/EDS3170 only)
2. In the same way, use DAC-P - GHOST-G: in the Adjustment menu to adjust so that G color ghost is at a minimum.
3. In the same way, use DAC-P - GHOST-B: in the Adjustment menu to adjust so that B color ghost is at a minimum.

4-3 Flicker adjustment (V.COM adjustment)

Signals for internal adjustment

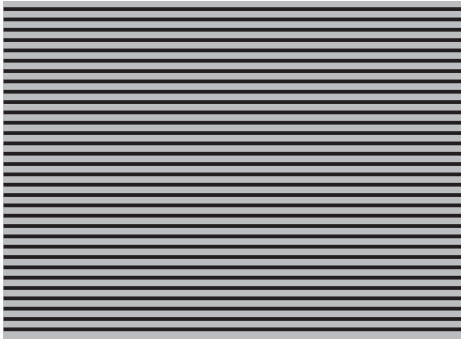

Adjustment procedure

1. Make this adjustment after completing the adjustment in 4-2 Ghost adjustment.
2. Use DAC-P - V.COM - R: in the Adjustment menu to adjust so that the flicker at the center of the screen is less than the flicker at the periphery. (When the flicker is about the same across the whole screen, adjust so that the flicker at the center of the screen is somewhat less than elsewhere.)
3. In the same way, use DAC-P - V.COM-G: in the Adjustment menu to adjust the G color flicker.
4. In the same way, use DAC-P - V.COM-B: in the Adjustment menu to adjust the B color flicker.

CPS317/EDS3170/EDS3170A

4-4 PSIG-G adjustment (vertical stripe adjustment)

Signals for internal adjustment

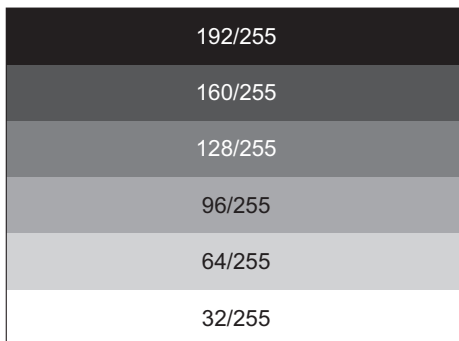

Adjustment procedure

1. Make this adjustment after completing the adjustment in 4-3 Flicker adjustment.
2. Use DAC-P - PSIG - G: in the Adjustment menu to adjust so that the vertical lines spaced every 6 or 12 dots are as inconspicuous as possible.

4-4-1 PSIG-B adjustment (vertical streaks adjustment)

Signals for internal adjustment

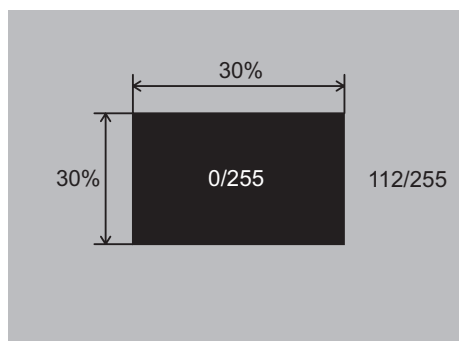

Adjustment procedure

1. Make this adjustment after completing the adjustment in 4-3 Flicker adjustment.
2. Use DAC-P - PSIG - B: in the Adjustment menu to adjust so that the vertical streaks on the upper of window pattern.

CPX327/EDX3270/EDX3270A

4-4 NRSH adjustment (vertical stripe adjustment)

Signals for internal adjustment

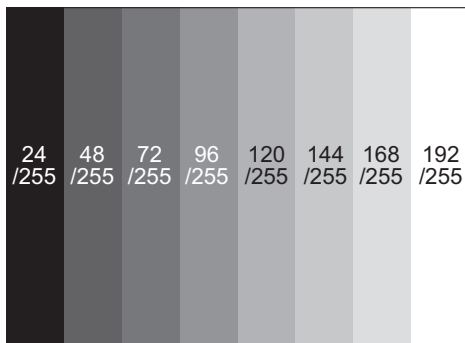

Adjustment procedure

1. Make this adjustment after completing the adjustment in 4-3 Flicker adjustment.
2. Use DAC-P - NRSH - R: in the Adjustment menu to adjust so that the vertical lines spaced every 6 dots are as inconspicuous as possible.
(Reduce the adjustment value when black stripes appear in the 2nd or 3rd tone from the black side. Note that when the adjustment value is lowered, white stripes may appear in the 2nd or 3rd tone from the bright side. Should this happen, adjust so that the stripes are as inconspicuous as possible.)
3. In the same way, use DAC-P - NRSH - G: in the Adjustment menu to adjust vertical stripes of G color.
4. In the same way, use DAC-P - NRSH - B: in the Adjustment menu to adjust vertical stripes of B color.

4-5 White balance adjustment (visual inspection)

Preparations

1. Perform these adjustments after the PSIG adjustment described in Section 4-4.

Adjustment procedure

1. First, adjust the G color.
2. Select GAMMA, SUB-CONTRAST, and G: in the Adjust menu. If the background is white solid, press the [MENU SELECT] key on the Remote control transmitter to change to [G] monochrome in the 28-tone grayscale.
3. Adjust GAMMA, SUB-CONTRAST, and G: in the Adjust menu so that brightness of 28 steps is best.
4. Don't adjust GAMMA, SUB-BRIGHT, and G: in the Adjust menu. Because we want to keep the best contrast ratio.
5. Then adjust colors R and B.

2. Reset gamma correction before adjustment.
 - Place the cursor on [GAMMA] in the Adjustment menu, press the [RESET] key and select [DEFAULT].
6. Select GAMMA, SUB-CONTRAST, and G: in the Adjust menu. If the background is white solid, press the [MENU SELECT] key on the Remote control transmitter to change to [W] monochrome in the 28-tone grayscale.
7. Adjust GAMMA, SUB-BRIGHT, R: and B: in the Adjust menu so that low-brightness white balance is best.
8. Adjust GAMMA, SUB-CONTRAST, R: and B: in the Adjust menu so that middle-brightness white balance is best.
9. Repeat steps 7 to 8 above, and adjust so that brightness white balance of 28 steps is best.

4-6 Color uniformity adjustment

Preparations

1. Perform these adjustments after the white balance adjustment described in Section 4-5.
2. Make a color uniformity adjustment for the following four tones.
 - MIN tone (approx. 4% input signal)
 - MID-L tone (approx. 14% input signal)
 - MID-H tone (approx. 25% input signal)
 - MAX tone (approx. 57% input signal)
3. Place the cursor on the tone to be adjusted in the Adjust menu and press the [▼] key. This displays the Adjust Tone menu at the bottom of the screen. Select the major adjustment lattice point No. and color, and then adjust them.
4. The major adjustment lattice point numbers (a total of 17 points) corresponds to the major adjustment lattice point positions in the diagram on the right. The color uniformity of the entire screen can be adjusted by adjusting the white balance for each of the points starting in order from the low numbers.
5. Adjustment point No.1 should not be adjusted, because it controls the brightness of the entire screen.
6. To temporarily turn correction off, place the cursor on "ON" in the Adjust Tone menu and press the [▼] key. To turn it on again, place the cursor on OFF in the Adjust Tone menu and press the [▲] key.
7. Although this adjustment can also be made using internal signals, we will here use the [MENU SELECT] key on the Remote control transmitter to select the following two signals.
 - Solid monochrome adjustment color (use G color adjustment when a color differential meter is used).
 - Solid white (use for adjustment other than above).
8. Reset color-shading correction before adjustment.
 - When 4 tones and all colors are to be reset, place the cursor on [C.UNIF.] in the Adjustment menu, press the [RESET] key and select [DEFAULT].
 - When only 1 tone is to be reset, place the cursor on the tone to be reset, press the [RESET] key and select [DEFAULT].
 - Single tone and monochrome resets cannot be performed.

Adjust menu

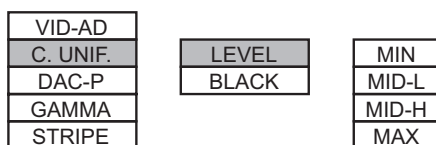

Adjust Tone menu

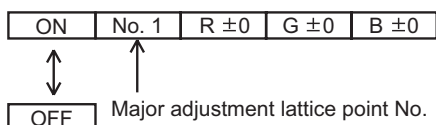

Major adjustment lattice point position

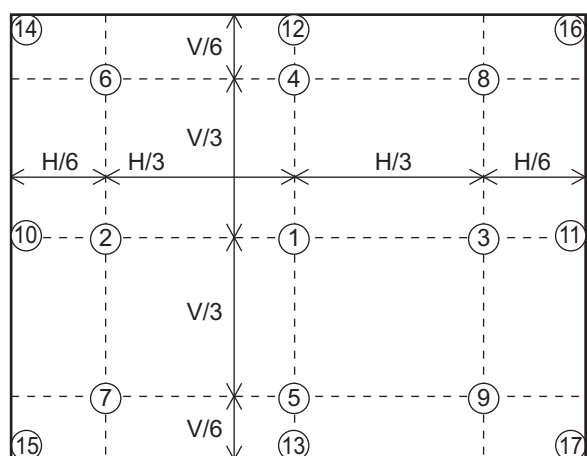

Adjustment procedure 1

(when a color differential meter is used)

1. First adjust [MID-L] tone [G:].
2. Select adjustment point [No.2][G:].
When the background is not [G] monochrome, press the [MENU SELECT] key on the Remote control transmitter to change to solid [G] monochrome.
3. Measure the illumination at adjustment points No. 2, No.3, No.10 and No.11.
The values should be:
No.2 = Y2 [lx] No.10 = Y10 [lx]
No.3 = Y3 [lx] No.11 = Y11 [lx]
4. No.2 and No.3 adjustment point have the average of Y2 and Y3.
 $Y2 = (Y2 + Y3) / 2 \pm 2 [\%]$
 $Y3 = (Y2 + Y3) / 2 \pm 2 [\%]$
5. No.10 and No.11 adjustment point have the average of Y10 and Y11.
 $Y10 = (Y10 + Y11) / 2 \pm 2 [\%]$
 $Y11 = (Y10 + Y11) / 2 \pm 2 [\%]$
6. Then adjust [MID-L] tone [R] and [B].
When the background is [G] monochrome, press the [MENU SELECT] key on the Remote control transmitter to change to solid white.
7. Measure the color coordinates of adjustment point [No.1] and make a note of them.
Assume that they are $x = x1$, $y = y1$.
Note: When the CL-100 color and color difference meter is used, the $[\Delta]$ (delta) mode is convenient. When adjustment point [No.1] color coordinate has been selected, set the slide switch on the side to $[\Delta]$ (delta) while holding down the [F] button on the front panel. The measurement shown after this displays the deviation from measurement point 1.
8. Measure the color coordinates of measurement point [No.2] and adjust [No.2][R:] and [B:] so that the coordinates are as follows.
 $x = x1 \pm 0.005$, $y = y1 \pm 0.010$

9. Similarly, measure adjustment points [No.3] to [No.17] and adjust their color coordinates starting in order from the small number points.
This completes adjustments required for [MIN].
Note: Since excessive correction may lead to a correction data overview during internal calculations, use the following values for reference.
[No.2] to [No.5] ± 40 or less
[No.6] to [No.9] ± 50 or less
[No.10] to [No.13] ± 70 or less
[No.14] to [No.17] ± 120 or less
10. Then adjust [MIN] tone [G] so that the adjustment data set two times as much as [MID-L] tone [G].
This completes [G] color adjustments.
11. Then adjust [MIN] tone [R] and [B].
Select [No.2] [B:] and press the [MENU SELECT] key on the Remote control transmitter to change to solid white.
12. Measure the color coordinates of adjustment point [No.1] and make a note of them.
Assume that they are $x = x1$, $y = y1$.
13. Now measure the color coordinates of measurement point [No.2] and adjust [No.2][R:] and [B:] so that the coordinates are as follows.
 $x = x1 \pm 0.005$, $y = y1 \pm 0.010$ (Target)
 $x = x1 \pm 0.020$, $y = y1 \pm 0.040$
14. Similarly, measure adjustment points [No.3] to [No.17] and adjust their color coordinates starting in order from the small number points.
This completes [MIN] tone adjustments.
15. Now make similar adjustments for [MID-H] tone.
(Adjust [MID-H] tone [G] so that the adjustment data set half as many as [MID-L] tone [G].)
16. Now make similar adjustments for [MAX] tone.
(Adjust [MAX] tone [G] so that the adjustment data set half as many as [MID-L] tone [G].)

Adjustment procedure 2

(visual inspection)

1. First adjust [MIN] tone [G:].
2. Select [No.2] [G:].
If the background is [G] monochrome, press the [MENU SELECT] key on the Remote control transmitter to change to solid white.
3. View measurement point [No.2] and [No.3].
Lower the [G] color intensity only of the color point whose [G] color is more intense than measurement point [No.1].
4. View measurement point [No.10] and [No.11].
Lower the [G] color intensity only of the color point whose [G] color is more intense than measurement point [No.1], and raise the intensity of the point whose color intensity is lower than measurement point [No.1].
5. Now adjust the [MIN] tone for colors [R] and [B].

6. View measurement points [No.2], [No.3], [No.10] and [No.11]. Adjust the [R] and [B] of each measurement point so that they have the same color as measurement point [No.1].

Adjustment technique:

First, adjust [B:] of the point whose color is to be adjusted so that it approximates that of [No.1]. If [R:] is low at this time, the image will have cyan cast, in which case [R:] is increased. On the other hand, if [R:] is excessive, the image will have a magenta cast, in which case [R:] is decreased.

Overall, a cyan cast makes it easy to see color shading.

7. Next, view measurement points [No.4], [No.5], [No.12], [No.13] and make similar adjustments.
8. Then adjust measurement points [No.6], [No.7], [No.8], [No.9], [No.14], [No.15], [No.16] and [No.17]. This completes the [MIN] tone adjustments.
9. Make similar another three tones as described in steps 1 to 8 above.

No. 2 deviation range

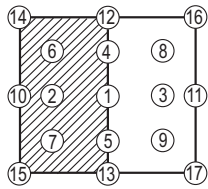

No. 10 deviation range

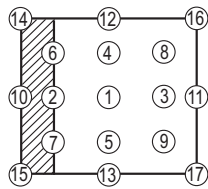

No. 3 deviation range

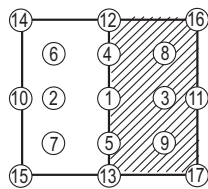

No. 11 deviation range

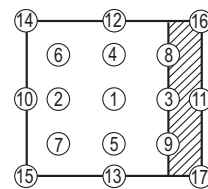

No. 4 deviation range

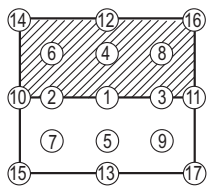

No. 12 deviation range

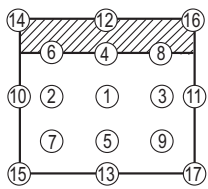

No. 5 deviation range

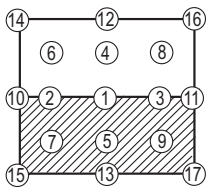

No. 13 deviation range

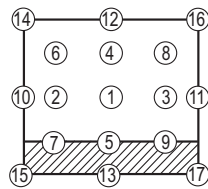

No. 6 deviation range

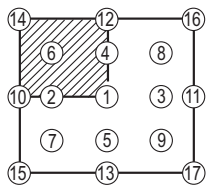

No. 7 deviation range

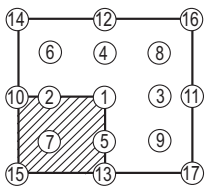

No. 8 deviation range

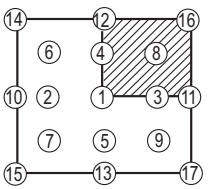

No. 9 deviation range

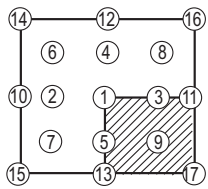

No. 14 deviation range

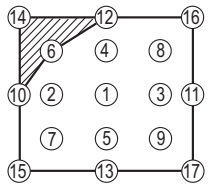

No. 15 deviation range

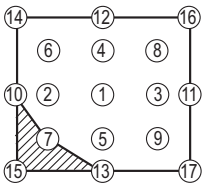

No. 16 deviation range

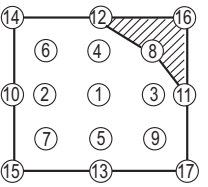

No. 17 deviation range

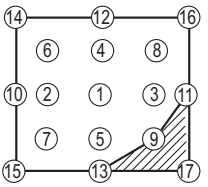

5. Troubleshooting

Check points at trouble shooting

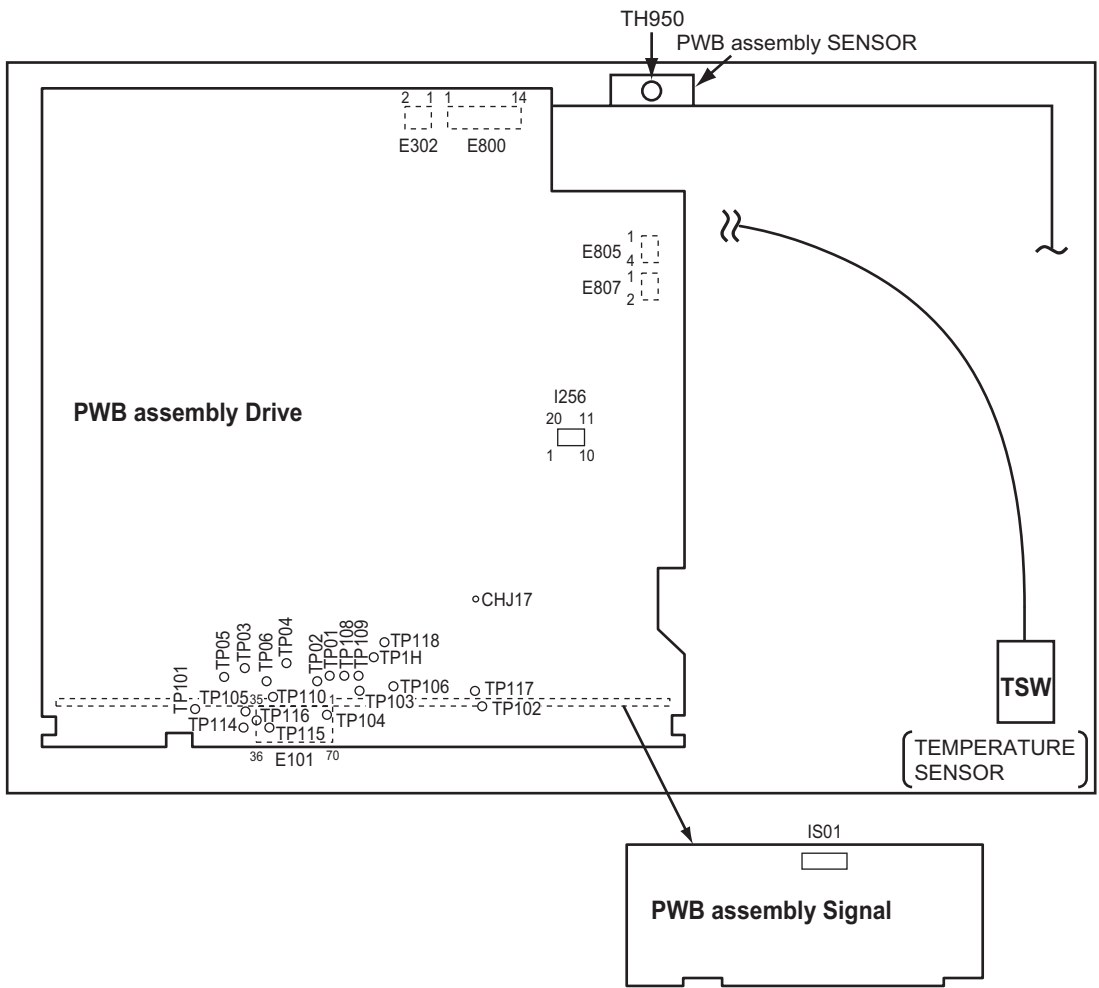

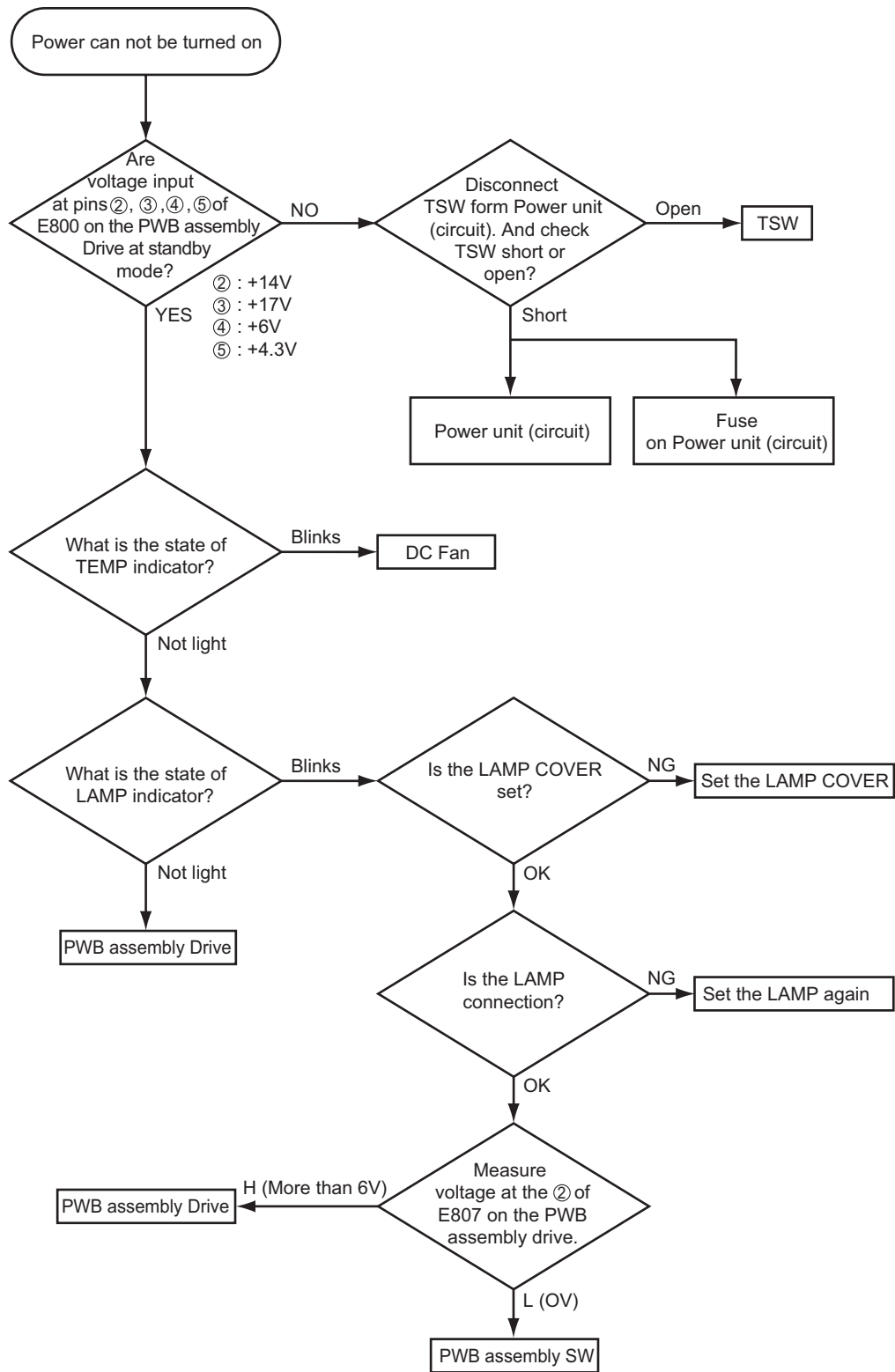

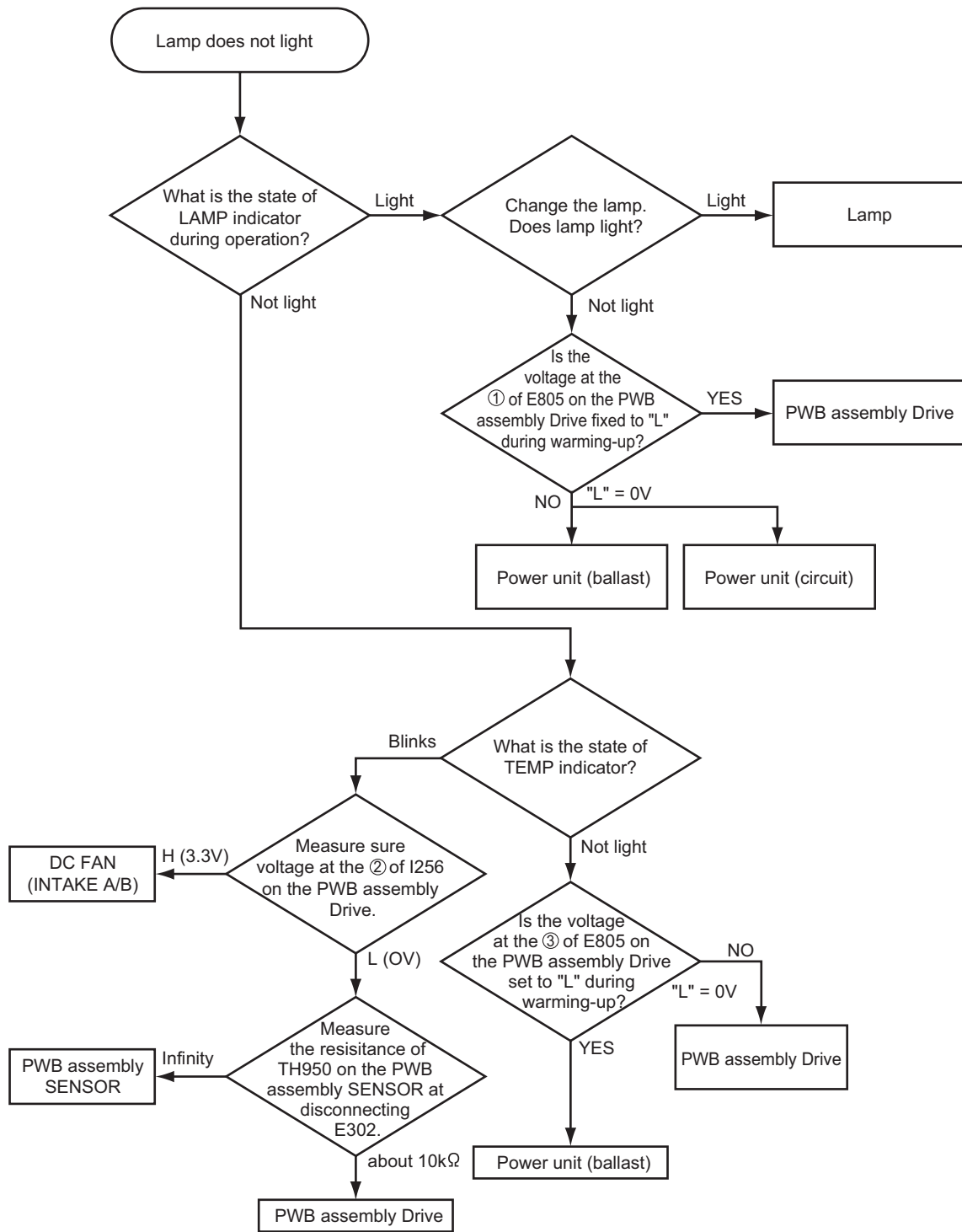

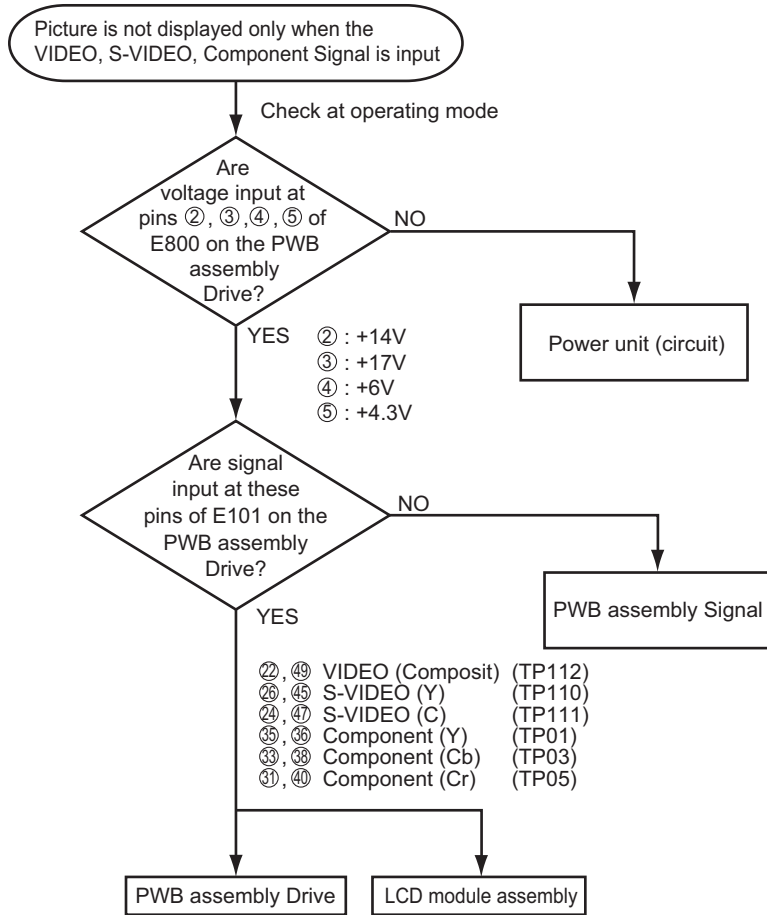
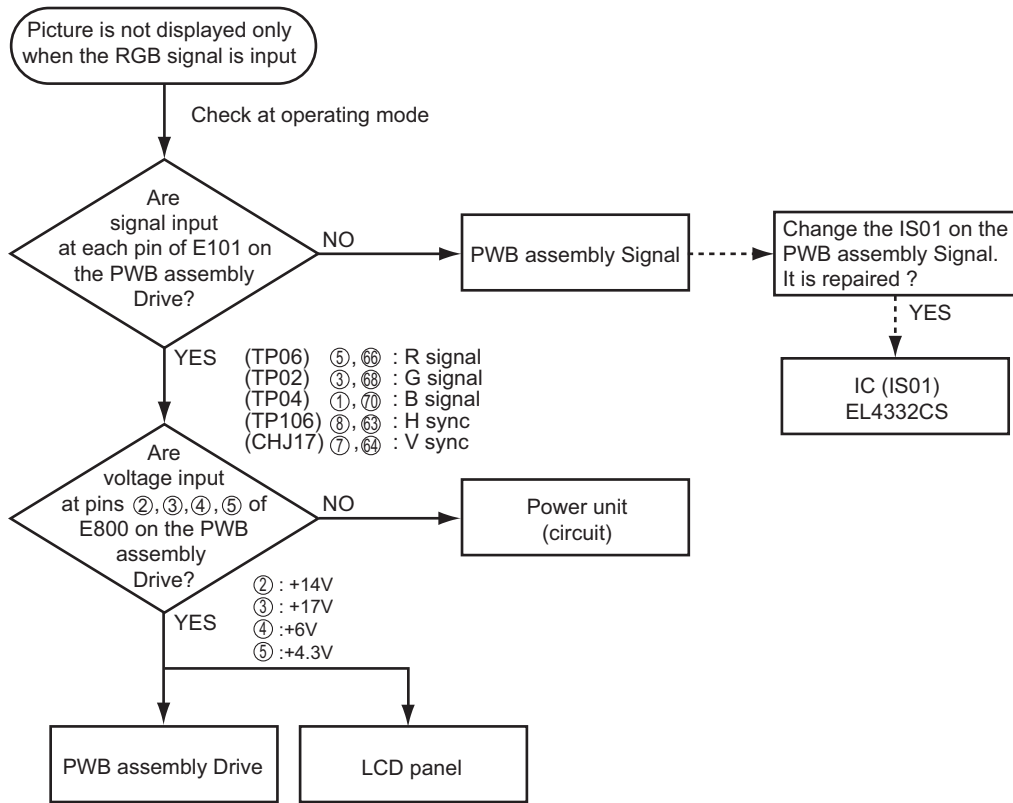

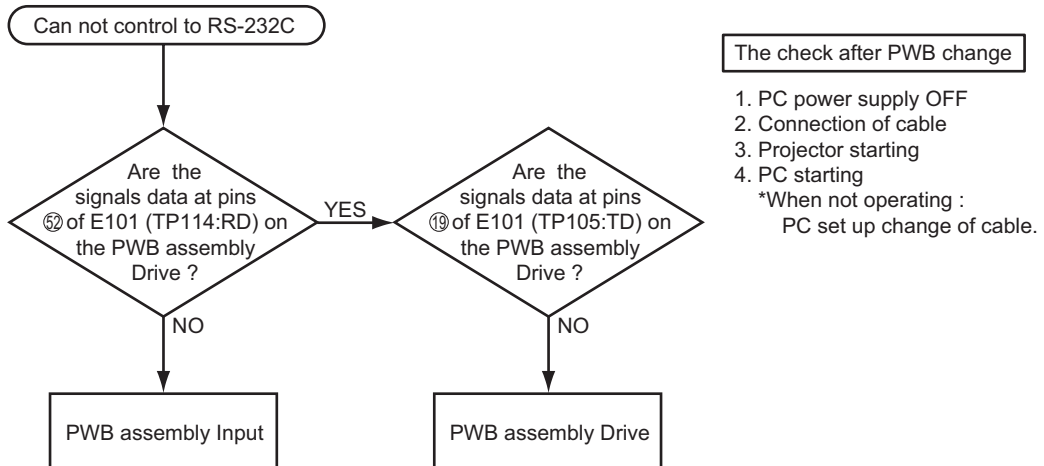
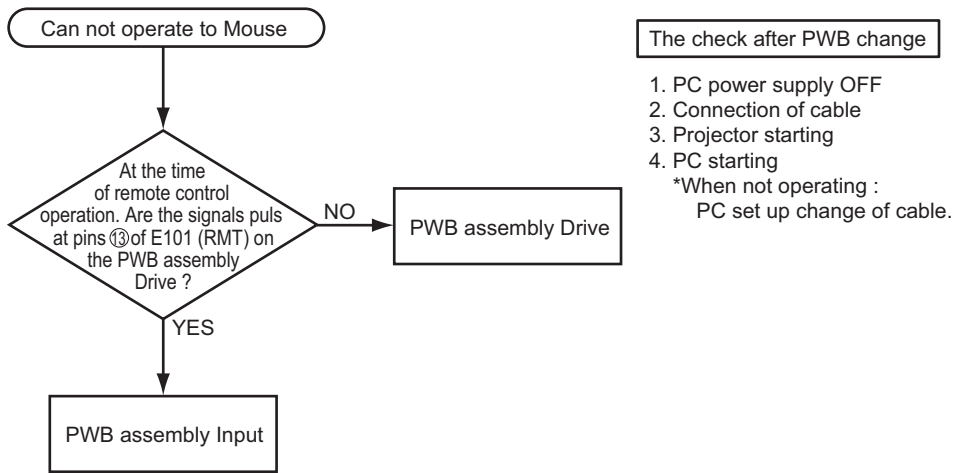
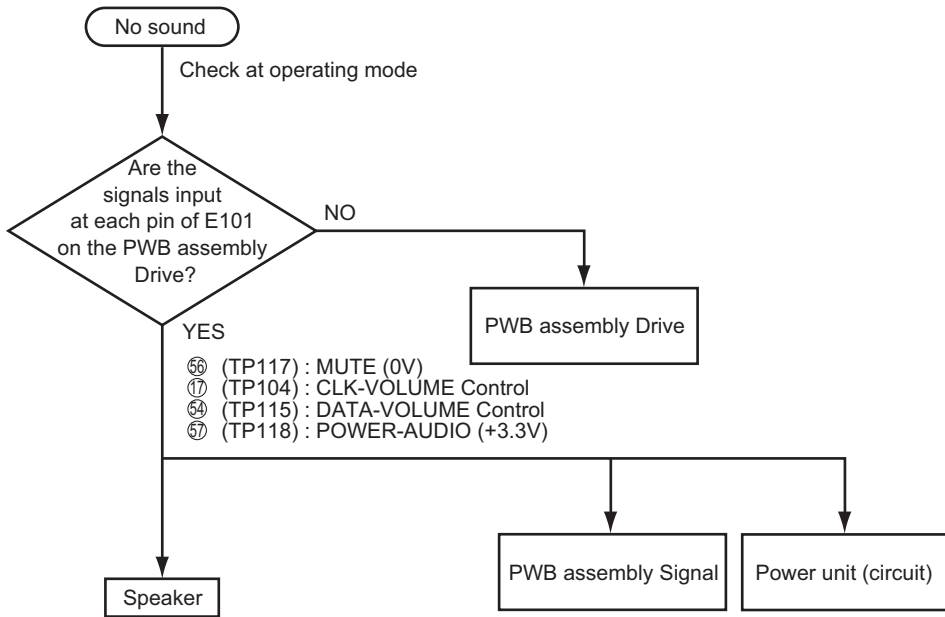

6. Service points

● Lead free solder [CAUTION]

This product uses lead free solder (unleaded) to help preserve the environment. Please read these instructions before attempting any soldering work.

Caution: Always wear safety glasses to prevent fumes or molten solder from getting into the eyes. Lead free solder can splatter at high temperatures (600°C).

■ Lead free solder indicator

Printed circuit boards using lead free solder are engraved with an "F."

■ Properties of lead free solder

The melting point of lead free solder is 40-50°C higher than leaded solder.

■ Servicing solder

Solder with an alloy composition of Sn-3.0Ag-0.5Cu or Sn-0.7Cu is recommended.

Although servicing with leaded solder is possible, there are a few precautions that have to be taken. (Not taking these precautions may cause the solder to not harden properly, and lead to consequent malfunctions.)

Precautions when using leaded solder

- Remove all lead free solder from soldered joints when replacing components.
- If leaded solder should be added to existing lead free joints, mix in the leaded solder thoroughly after the lead free solder has been completely melted (do not apply the soldering iron without solder).

■ Servicing soldering iron

A soldering iron with a temperature setting capability (temperature control function) is recommended.

The melting point of lead free solder is higher than leaded solder. Use a soldering iron that maintains a high stable temperature (large heat capacity), and that allows temperature adjustment according to the part being serviced, to avoid poor servicing performance.

Recommended soldering iron:

- Soldering iron with temperature control function (temperature range: 320-450°C)

Recommended temperature range per part:

| Part | Soldering iron temperature |
|---------------------------------|----------------------------|
| Mounting (chips) on mounted PCB | 320°C±30°C |
| Mounting (chips) on empty PCB | 380°C±30°C |
| Chassis, metallic shield, etc. | 420°C±30°C |

The PWB assembly which has used lead free solder

- ① PWB assembly DRIVE
- ② PWB assembly INPUT
- ③ PWB assembly SENSOR
- ④ PWB assembly SWITCH
- ⑤ PWB assembly REMOTE

6. Service points

● Cautions when removing the PWB assembly Drive

When removing the PWB assembly Drive, there is danger of damaging the connector connecting cables and the PWB assembly Signal.

- 1) Disconnect 6 cables and remove 3 screws.

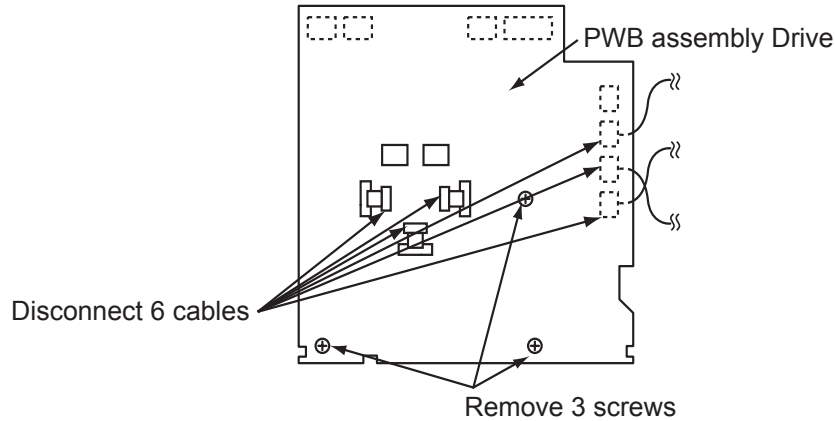

- 2) Lift up the rearward of the PWB assembly Drive to the front.

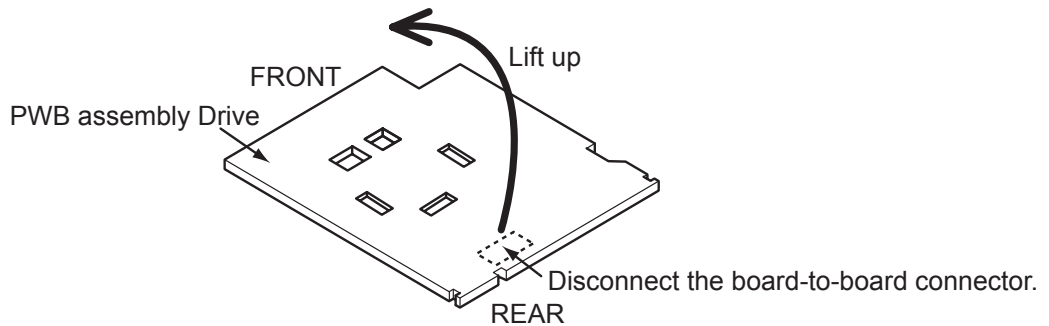

- 3) Disconnect 5 cables lifting the PWB assembly Drive.

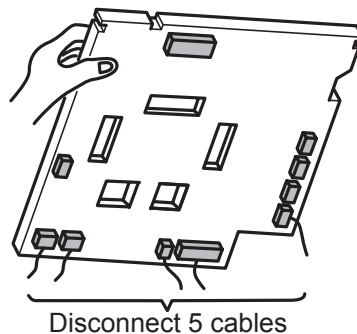

● Cautions when removing the POWER UNIT (BALLAST)

When removing the cable (CNBAR) connected to POWER UNIT (BALLAST) there is danger of damaging the small PWB connecting cables.

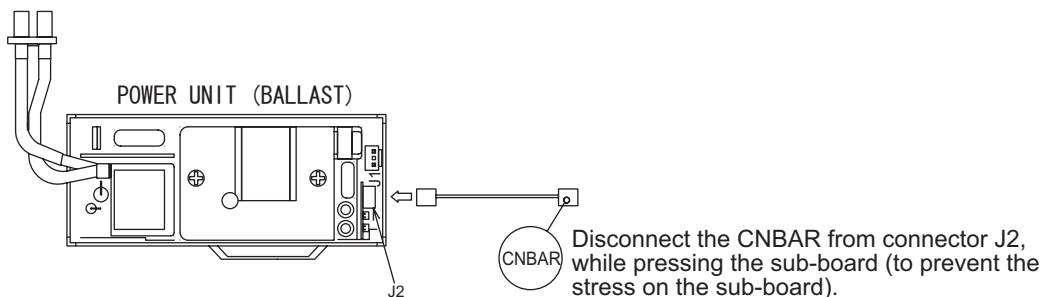

● Before Replacing the LCD / Lens Prism

You should not replace separately the parts of the liquid crystal LCD / Lens Prism because it works properly only when used together. Therefore, regarding these parts, you can either replace part , LCD / Lens Prism assembly, or send the whole unit LCD / Lens Prism assembly back to Hitachi, where we will replace the malfunctioning part, recondition the device and send it back to you.

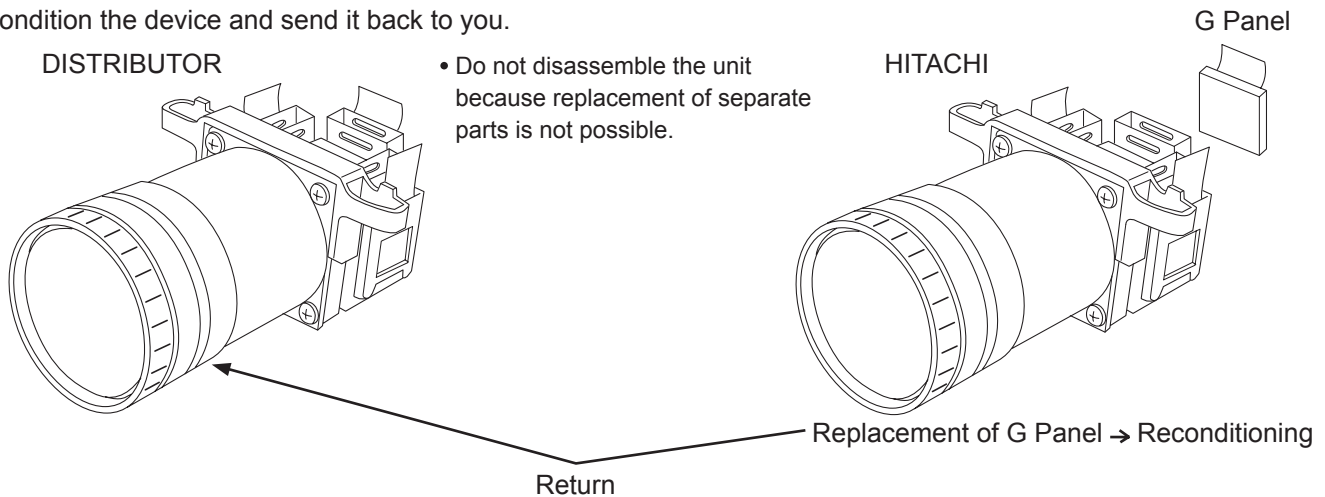

● Using the Remote control

CAUTION Precautions to observe in regards to the batteries

Always handle the batteries with care and use them only as directed. Improper use may result in battery cracking or leakage, which could result in fire, injury and/or pollution of the surrounding environment.

- Keep the battery away from children and pets.
- Be sure to use only the batteries specified for use with the remote control. Do not mix new batteries with used ones.
- When inserting batteries, verify that the plus and minus terminals are aligned correctly (as indicated in the remote control).
- When you dispose the battery, you should obey the law in the relative area or country.

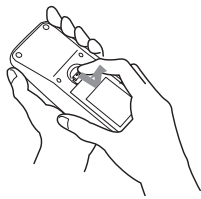
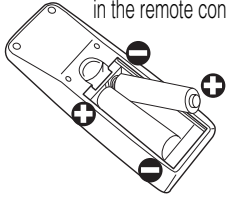
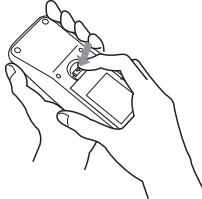
| | | |
|--|--|---|
| <p>1 Remove the battery cover</p> <p>Slide back and remove the battery cover in the direction of the arrow.</p>  | <p>2 Insert the batteries</p> <p>Align and insert the two AA batteries (that came with the projector) according to their plus and minus terminals (as indicated in the remote control).</p>  | <p>3 Close the battery cover</p> <p>Replace the battery cover in the direction of the arrow and snap it back into place.</p>  |
|--|--|---|

● Caring for the air filter

The air filter should be cleaned about every 100 hours. If the LAMP indicator and TEMP indicator blink red simultaneously, or a message prompts you to clean the air filter when you turn on the unit, the filter needs to be cleaned. (See "Related Messages" and "Regarding the Indicator Lamps" for details.)

1 Turn off the projector, and unplug the power cord

2 Apply a vacuum cleaner to the top of the air filter cover to clean the air filter

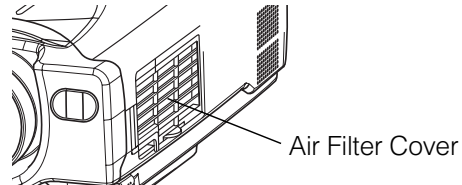

3 Turn on the projector, and use the menu to reset the filter timer

- To reset the air filter timer, from the OPTION menu, select FILTER TIME. (Select RESET on the menu with the ▲ button.)

● Lamp (Option Lamp: DT00511(CPS317/EDS3170/EDS3170A) / DT00521(CPX327/EDX3270/EDX3270A))



HIGH VOLTAGE
HIGH TEMPERATURE
HIGH PRESSURE

Before replacing the lamp, check the serial number of the replacement lamp bulb (sold separately: DT00511 for CPS317/EDS3170/EDS3170A or DT00521 for CPX327/EDX3270/EDX3270A), then contact your local dealer. Before replacing the lamp, turn off the power, and unplug the power cord, then wait at least 45 minutes, in order to ensure that the lamp is properly cooled. Removing the lamp bulb while it is still hot could cause burns, or cause the lamp bulb to burst.

⚠ WARNING The LCD projector uses a glass lamp bulb. It is a mercury lamp with high internal pressure. High-pressure mercury lamps can break with a loud bang, or burn out, if jolted or scratched, or through wear over time. Each lamp has a different lifetime, and some may burst or burn out soon after you start using them. In addition, when the bulb bursts, it is possible for shards of glass to fly into the lamp housing, and for gas containing mercury to escape from the projector's vent holes.

- Handle with care: jolting or scratching could cause the lamp bulb to burst during use.
- If the replace lamp indicator (see "Related Messages" and "Regarding the indicator Lamps") comes on, replace the lamp as soon as possible. Using the lamp for long periods of time, or past the replacement date, could cause it to burst. Do not use old (used) lamps; this is a cause of breakage.
- If the lamp breaks soon after the first time it is used, it is possible that there are electrical problems elsewhere besides the lamp. If this happens, contact your local dealer.
- If the lamp should break (it will make a loud bang when it does), ventilate the room well, and make sure not to breathe the gas that comes out of the projector vents, or get it in your eyes or mouth.
- If the lamp should break (it will make a loud bang when it does), unplug the power cord from the outlet, and make sure to request a replacement lamp from your local dealer. Note that shards of glass could damage the projector's internals, or cause injury during handling, so please do not try to clean the projector or replace the lamp yourself.
- Obey local ordinances when disposing of used lamps. In most cases, it is possible to dispose of used bulbs in the same manner as used glass bottles, but in some cases, bulbs are sorted separately.
- Do not use the projector with the lamp cover removed.

● Replacing the Lamp

All projector lamps will wear out eventually. If used for long periods of time, the image could become darkened, and the color contrast could be impacted as well. We recommend that you replace your lamps early. If the LAMP indicator turns red, or a message prompts you to replace the lamp when you power up the projector, the lamp needs to be replaced. (See "Related Messages" and "Regarding the Indicator Lamps" for details.)

- 1** Turn off the projector, and unplug the power cord. Allow the lamp bulb to cool for at least 45 minutes, and prepare a new lamp (sold separately: DT00511 for CPS317/EPS3170/EPS3170A or / DT00521 for CPX327/EDX3270/EDX3270A)

- 2** After making sure that the projector has cooled adequately, slowly flip over the projector, so that the bottom is facing up

- 3** Unscrew the 2 screws, and remove the lamp cover

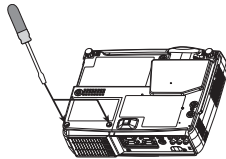

- 4** Unscrew the 1 screw, and slowly pull out the lamp by the handle
- Be careful not to touch the inside of the lamp case.

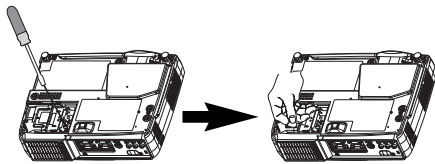

- 5** Insert the new lamp, and tighten the 1 screw firmly to lock it in place
- Also steadily push the opposite side of the screwed side of the lamp into the unit.

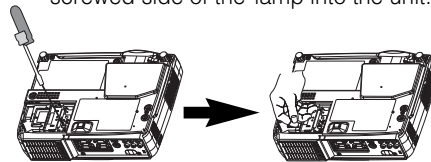

- 6** Replace the lamp cover, and tighten the 2 screws firmly to lock it in place

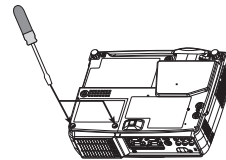

- 7** Slowly turn the projector so that the top is facing up

- 8** Turn on the projector power, and using the menu, reset the lamp timer
- To reset the lamp timer, from the OPTION menu, select LAMP TIME.

ATTENTION

- Make sure that the screws are screwed in firmly. Loose screws could result in damage or injury.
- Do not use with lamp cover removed.
- Do not reset the lamp timer without replacing the lamp. Reset the lamp timer always when replacing the lamp. The message functions will not operate properly if the lamp timer is not reset correctly.
- When the lamp has been replaced after the message of "CHANGE THE LAMP ...THE POWER WILL TURN OFF AFTER 0 hr." is displayed, or the LAMP indicator is red, complete the following operation within 10 minutes of switching power ON.

NOTE

- The LAMP indicator is also red when the lamp unit reaches high temperature. Before replacing the lamp, switch power OFF, wait approximately 20 minutes, and switch power ON again. If the LAMP indicator is still red, replace the lamp.

● Resetting the Lamp Timer

Reset the lamp timer after replacing the lamp. When the lamp has been replaced after the LAMP indicator is red, or the CHANGE THE LAMP message is displayed, complete the following operation within ten minutes of switching power ON. The power will be turned off automatically in over 10 minutes.

1. Switch power ON, and select the LAMP TIME on the OPTION menu.
2. Depress the RESET button for at least 3 seconds while lamp time is being displayed.
The reset menu will then appear.
3. Select RESET on the menu with the ▲ button, and wait until the timer display is cleared.

NOTE:

Do not reset the lamp timer without replacing the lamp. Reset the lamp timer always when replacing the lamp. The message functions will not operate properly if the lamp timer is not reset correctly.

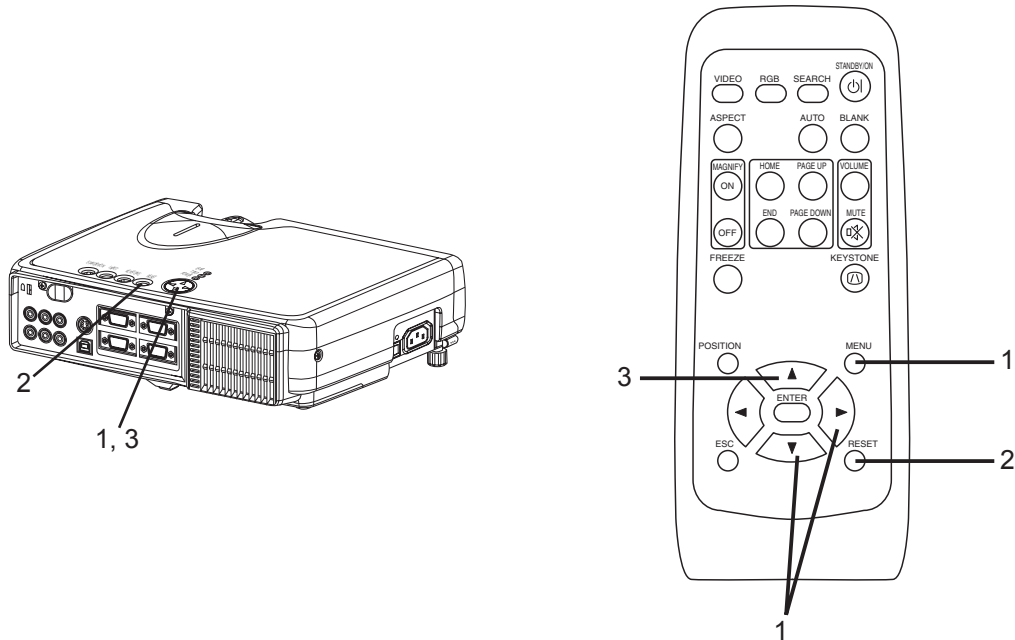

● Notice of AUTO adjustment

Use of AUTO adjustment with the image through RGB input optimizes VPOSI, HPOSI, HSIZE and HPHASE automatically.

In case that projected image has dark tone around its peripheral, AUTO operation sometimes makes artifacts in the image, shifts capture area and so on. Those failures are caused by period of image data is not exactly distinguished to period of blanking on signal processing.

To avoid such phenomena, AUTO function should be used with the full size picture that has bright tone on its peripheral.

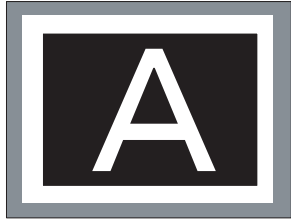

Image when AUTO operates correctly



Image when AUTO fails.

- Noting image of top or bottom lines.
- Shift of the image to East or West.
- Artifacts on image. Etc.

Note

- 1) The phenomenon at the failure of AUTO adjustment depends on resolution of input source, scene of picture etc.
- 2) There is no failure above in AUTO with video source through VIDEO, S-VIDEO or COMPONENT input. The reason is why recognition of input signal's standard does not need to search the capture range from input signal itself.

● PIN LOCK System

If the following PIN BOX menu appears after power on the projector, the PIN LOCK system has been activated. Under such a condition, key operations and signal displaying are inhibited. To open the PIN LOCK system, we need to input the correct 4 digits PIN CODE. If correct PIN CODE is not input in 5 min., the lamp will be automatically turned off.

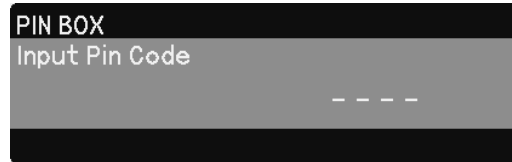

PIN BOX

Returning repaired unit

Use the Master PIN code. See the paragraph of Releasing the PIN LOCK system inactivation.

Swap unit/Returned unit

Inactivate the PIN LOCK system. See the paragraph of the PIN LOCK system inactivation.

Releasing the PIN LOCK System

When the PIN BOX menu is displayed, sequentially enter the codes with remote controller as follows. In accordance with remote controller button entry, "*" mark appears in the PIN BOX menu.

Master PIN codes

1st entry code: Press the "MENU" button.

2nd entry code: Press the "▼" button.

3rd entry code: Press the "KEYSTONE" button.

4th entry code: Press the "▲" button.

Note: The Master PIN codes can be used up to 30 times. The codes cannot be used thereafter. If the Master PIN codes cannot be used, see the paragraph of the PIN LOCK system inactivation.

The PIN LOCK System inactivation

1. When the PIN BOX menu is displayed, press "RESET" for 3 seconds or more in order to get the ID Inquiring Code.



PIN BOX (ID Inquiring Code)

2. Send HITACHI sales company the Inquiring code (10 digits) to inquire the correct PIN code.

3. With the PIN BOX menu displayed, input the correct PIN code. Enter the correct PIN CODE that HITACHI sales company informed.

4. Open menu and select "TURN OFF" from the PIN LOCK items in the OPTION menu. Then the PIN BOX menu appears.

5. Input the correct PIN code in the PIN BOX menu.

6. And then, the OPTION menu appears.

After the PIN LOCK system is inactivated, the PIN BOX is no longer displayed in the OPTION menu.

If the PIN LOCK items are kept displaying, the PIN LOCK system is not inactivated yet. Input the correct PIN CODE again.

● Related Messages

When the unit's power is ON, messages such as those shown below may be displayed. When any such message is displayed on the screen, please respond as described below.

| Message | Description |
|--|---|
| CHANGE THE LAMP AFTER REPLACING LAMP, RESET THE LAMP TIMER. (Note 1) | Lamp usage time is approaching 2,000 hours. (Note 2) Preparation of a new lamp, and an early lamp change, is recommended. After you have changed the lamp, please be sure to reset the lamp timer. |
| CHANGE THE LAMP AFTER REPLACING LAMP, RESET THE LAMP TIMER. THE POWER WILL TURN OFF AFTER * * hr. (Note 1) | Lamp usage time is approaching 2,000 hours. A lamp change within * * hours is recommended. (Note 2) When lamp usage reaches 2,000 hours, the power will automatically be turned OFF. Please change the lamp by referring to "THE LAMP" in Vol.1 (Basic). After you have changed the lamp, please be sure to reset the lamp timer. |
| CHANGE THE LAMP AFTER REPLACING LAMP, RESET THE LAMP TIMER. THE POWER WILL TURN OFF AFTER 0 hr. | As lamp use has reached 2,000 hours, the power will soon be automatically turned OFF. (Note 2) Please immediately turn the power OFF, and follow the instructions in the "THE LAMP" section of the separate booklet, Vol.1 (Basic). After you have changed the lamp, please be sure to reset the lamp timer. |
| CLEAN THE AIR FILTER AFTER CLEANING AIR FILTER, RESET THE FILTER TIMER. | A note of precaution when cleaning the air filter. After cleaning the filter, operate FILTER TIME of the OPTION Menu, and perform reset of the filter timer. |
| NO INPUT IS DETECTED ON * * * | There is no input signal. Please confirm the signal input connection, and the status of the signal source. |
| SYNC IS OUT OF RANGE ON *** fH *****kHz fV *****Hz | The horizontal or vertical wavelength of the inputted signal is outside of the response parameters of this unit. Please confirm the specs for this unit or the signal source specs. |
| CHECK THE AIR FLOW | The internal portion temperature is rising. Please turn the power OFF, and allow the unit to cool down for approximately 20 minutes. After having confirmed the following items, then please resent the power to ON. <ul style="list-style-type: none"> • Is there blockage of the air passage aperture? • Is the air filter dirty? • Does the peripheral temperature exceed 35°C? |

NOTES

Note 1: Although this message will be automatically disappeared after around 3 minutes, it will be reappeared every time the power is turned ON.

Note 2: Lamps have a finite product life. Lamps are characterized by the fact that, after long hours of usage, a lamp will no longer light up, or the lamp will break or burst, etc. This unit is equipped with an automatic shut-down function, such that the power will automatically be turned OFF when lamp usage time has reached 2,000 hours. Please be aware, however, that among lamp types, there are major differences in product lifetimes; a lamp may thus fail to light even prior to the functioning of the automatic shut-down function of this unit.

● Regarding the Indicator Lamps

Lighting and flashing of the POWER indicator, the LAMP indicator, and the TEMP indicator have the meanings as described in the Table below.

Please respond in accordance with the instructions within the Table.

| POWER indicator | LAMP indicator | TEMP indicator | Description |
|-----------------------------------|--------------------------------------|--------------------------|--|
| The orange lamp is lighted | Turned OFF (Not lighted) | Turned OFF (Not lighted) | The STANDBY mode is set |
| Flashing of the green lamp | Turned OFF | Turned OFF | The unit is warming up. Please wait. |
| The green lamp is lighted | Turned OFF | Turned OFF | The unit is in an ON state. Ordinary operations may be performed. |
| Flashing of the orange lamp | Turned OFF | Turned OFF | The unit is cooling down. Please wait. |
| Blink of the red lamp | - | - | The unit is cooling down. Please wait. A certain error has been detected. Wait until the POWER indicator lamp has finished flashing, and then perform the proper response measure using the item descriptions below as reference. |
| The red lamp is lighted, or blink | The red lamp is lighted | Turned OFF | The lamp does not light. There is a possibility that the interior portion has become heated. Turn the power OFF and wait approximately 20 minutes. After the main unit has cooled down, please confirm whether or not there is blockage of the air passage aperture, whether or not the filter is dirty, and/or whether or not the peripheral temperature exceeds 35°C, etc. After performing any needed maintenance, turn the power ON again; if the same display is displayed, then please change the lamp. |
| The red lamp is lighted, or blink | Blink of the red lamp | Turned OFF | Either there is no lamp and/or lamp cover, or either of these has not been properly fixed (attached). Turn the power OFF and wait approximately 45 minutes. After the main unit has sufficiently cooled down, please make confirmation of the attachment state of the lamp and lamp cover. After performing any needed maintenance, turn the power ON again. |
| The red lamp is lighted, or blink | Turned OFF | Blink of the red lamp | The cooling fan is not operating. Turn the power OFF and wait approximately 20 minutes. After the main unit has cooled down, please make confirmation that no foreign matter has become caught in the fan, etc. After performing any needed maintenance, turn the power ON again. |
| The red lamp is lighted, or blink | Turned OFF | The red lamp is lighted | There is a possibility that the interior portion has become heated. Turn the power OFF and wait approximately 20 minutes. After the main unit has cooled down, please confirm whether or not there is blockage of the air passage aperture, whether or not the filter is dirty, and/or whether or not the peripheral temperature exceeds 35°C, etc. After performing any needed maintenance, turn the power ON again. |
| The green lamp is lighted | Alternative blink with the red lamp | | There is a possibility that the interior portion has become overcooled. Please use the unit within the usage temperature parameters (0°C to 35°C). Check the connector CNTH connecting. After performing any needed maintenance, turn the power ON again. |
| The green lamp is lighted | Simultaneous blink with the red lamp | | This is a notification that it is time to clean the filter. After cleaning the filter, operate the FILTER TIME portion of the OPTION Menu, and perform reset of the FILTER TIME. |

NOTE

When the interior portion has become overheated, for safety purposes, the power source is automatically turned OFF, and the indicator lamps may also be turned OFF. Press the "○" (power OFF) side of the main power switch, and wait for approximately 20 minutes. Please then use the unit only after having first confirmed that the unit has sufficiently cooled down.

SERVICE MENU

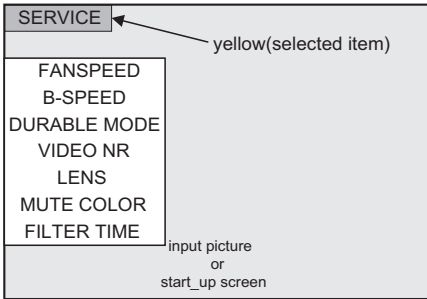

To display the OSD for “SERVICE MENU” set up.

| By the control panel | By the remote control transmitter |
|--|--|
| <ol style="list-style-type: none"> 1. Display the menu by the “MENU” button. 2. Select the “OPT.” on the menu. 3. Continue press the button “◀” first, then press the button “◀” together with “RESET”, and hold for 3 seconds. | <ol style="list-style-type: none"> 1. Display the menu by the “MENU” button. 2. Select the “OPT.” on the menu. 3. Continue pressing the button “MAGNIFY OFF” for 3 seconds. |

● Setup of a Cooling Fan Speed

When using this projector in the place where altitude is high, we recommend you to set a cooling fan’s speed as “HIGH”. It is because the cooling efficiency of a projector falls and the temperature inside a projector rises easily in such a place, since the density of air becomes low.

Setting Method of Cooling Fan Speed

1. Select the “FAN SPEED” on the OSD using button “▼” by the SERVICE MENU.

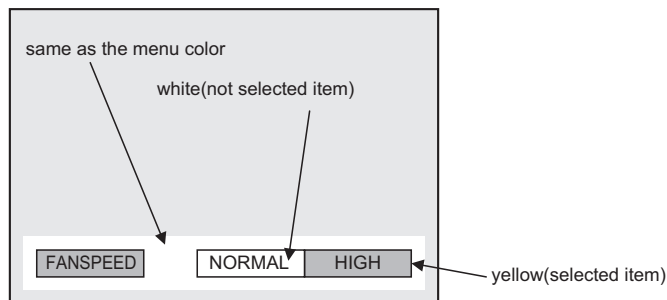

2. Select the “HIGH” on the OSD using the button “▶”. To reset this setup, select the “NORMAL” using the button “◀”.

3. The OSD will be ended by no operation for 10 seconds or change of input signal. To end immediately, use one of buttons except buttons “▲”, “▼”, “◀”, “▶”.

NOTE:

- The “HIGH” mode makes the fan noisy than “NORMAL” mode.
- The recall of factory setting sets the fan speed to “NORMAL” mode. You must set the fan speed after recall of factory setting if you need “HIGH” mode.

● **Setup of Filter time (“ON” or “OFF”)**

1. Select the “FILTER TIME” on the OSD using button “▼” by the SERVICE MENU.

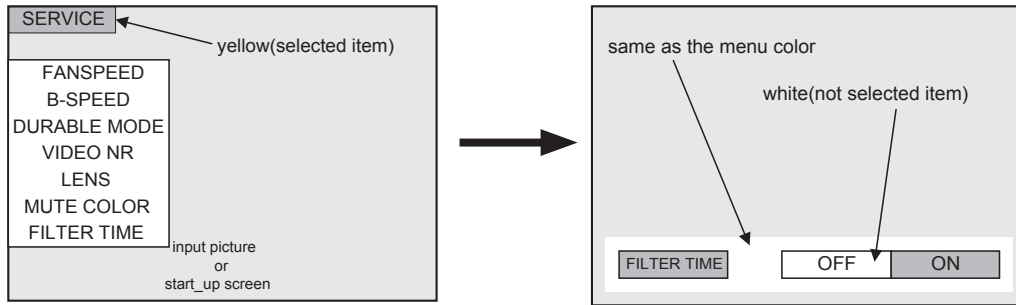

2. ON : Select the “ON” on the OSD using button “▶”.

OFF : Select the “OFF” on the OSD using button “◀”.

3. The OSD will be ended by no operation for 10 seconds or change of input signal. To end immediately, use one of buttons except buttons “▲”, “▼”, “◀”, “▶”.

● **EDS3170A & EDX3270A**

Set operating time display method (accumulated lamp time display method)

1. Select [Option] from the [Menu] display,,then select [Lamp Time].

2. Press the [Reset]button once,then press [Keystone]for 3 seconds or more to display the screen shown below.(The menu will close after 10 seconds if there are no further operations.)

3. Use “▼” or “▲” to select the usage status number.. (The usage status is as shown below.)

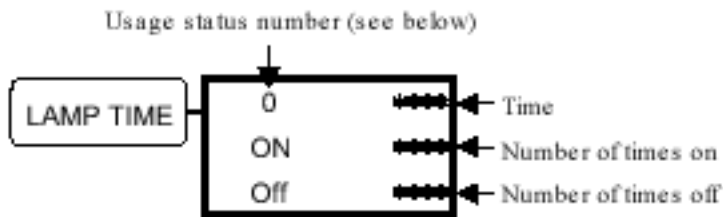

Usage status number

0Total usage status

1Current usage status

2Usage status before first reset

3Usage status before second reset

||

8Usage status before seventh reset

7. Block diagram (C3S3, C3XMS)

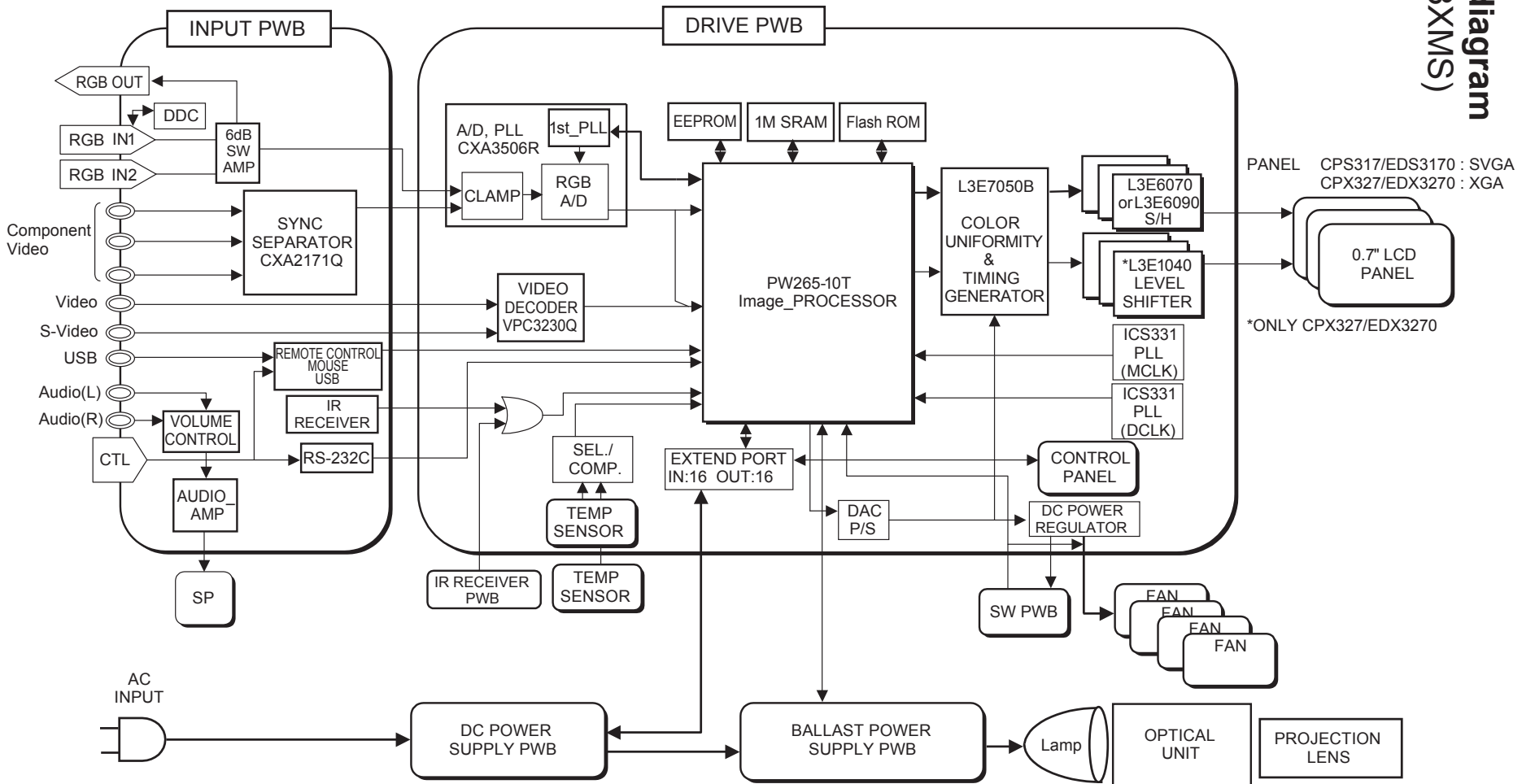

Block diagram (C3S3E, C3XM3E)

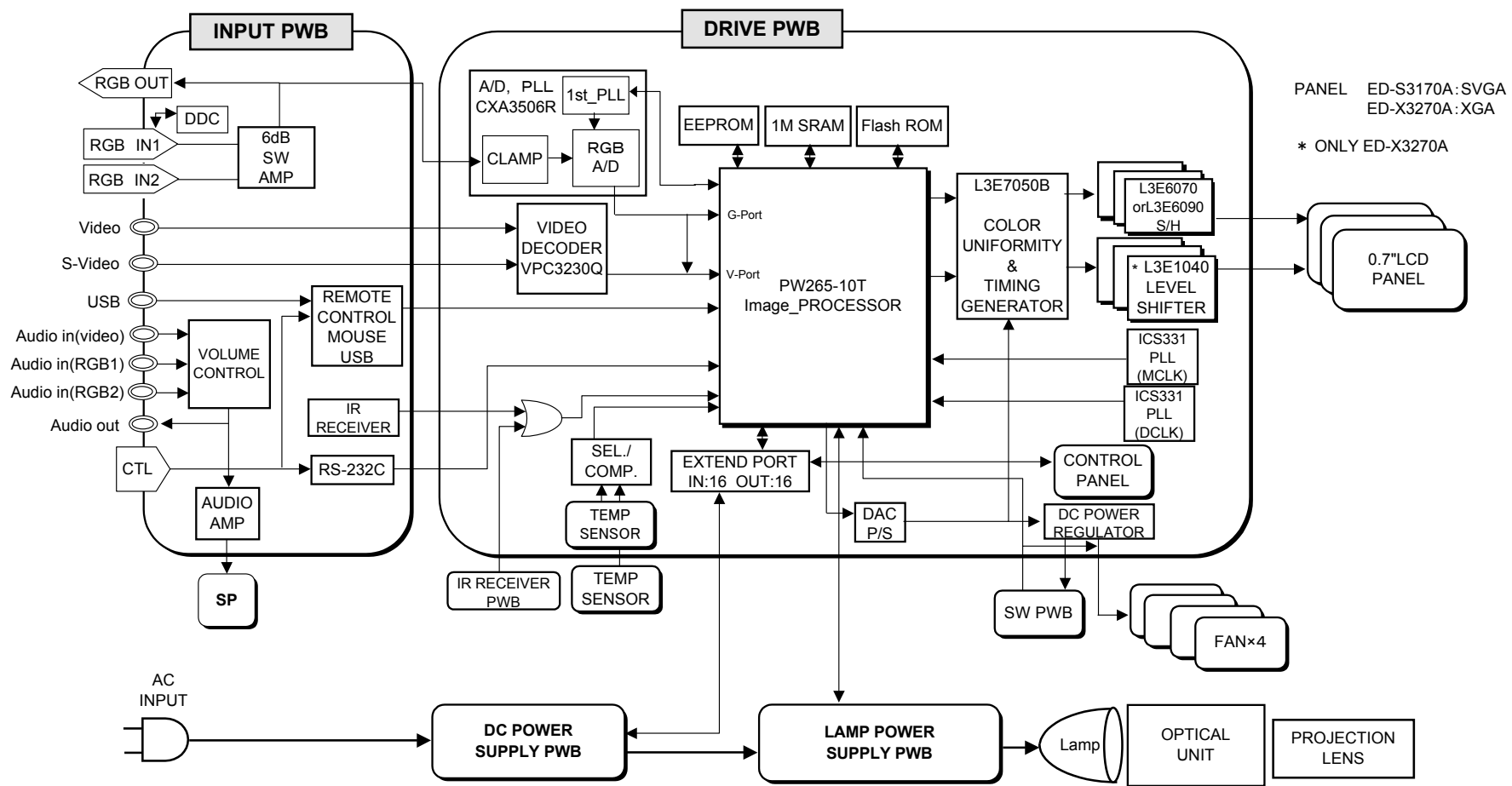

Block diagram (C3S3E/C3XM3E)

8. Connector connection diagram (C3S3, C3XM3)

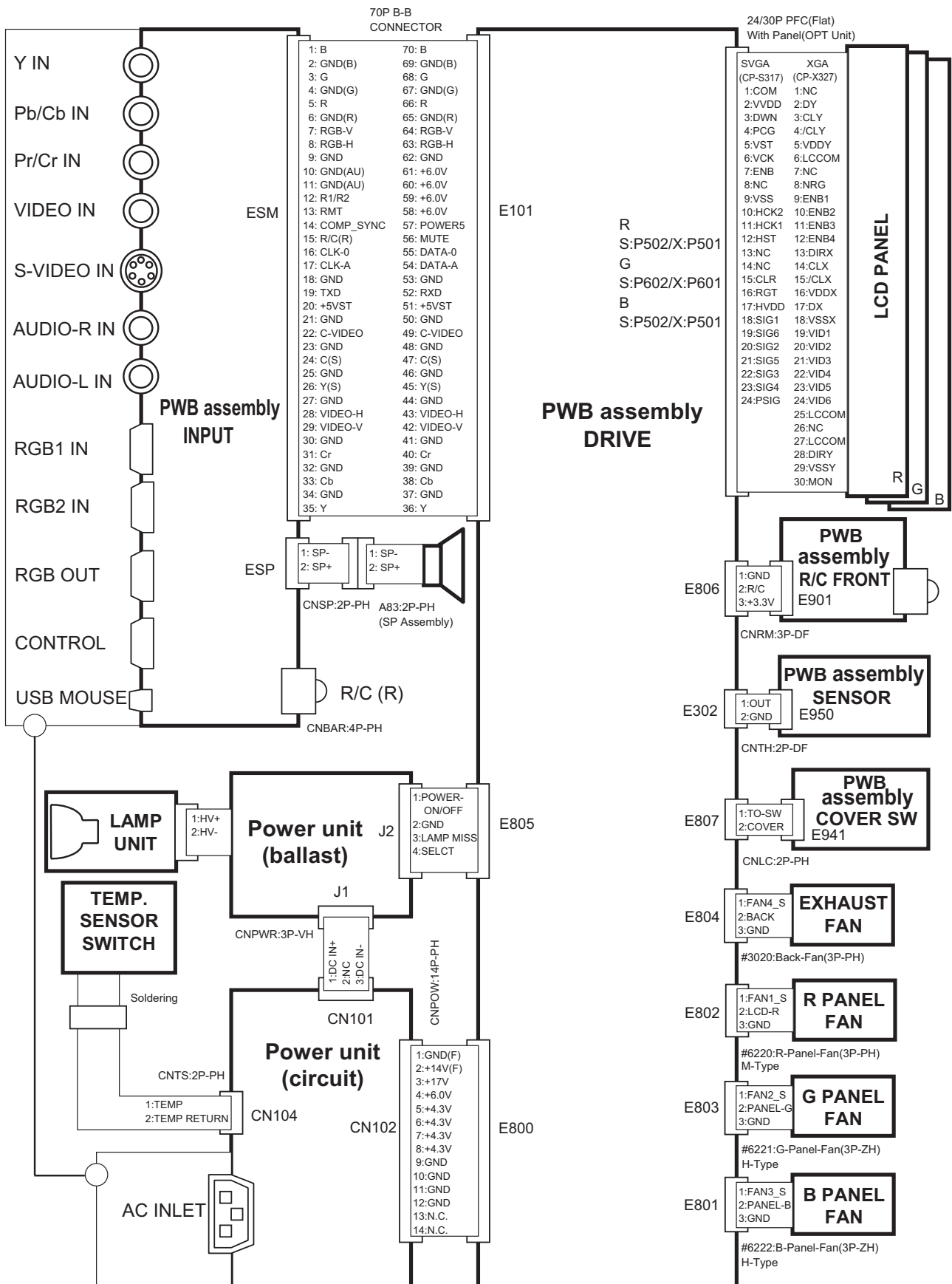

Connector connection diagram (C3S3E, C3XM3E)

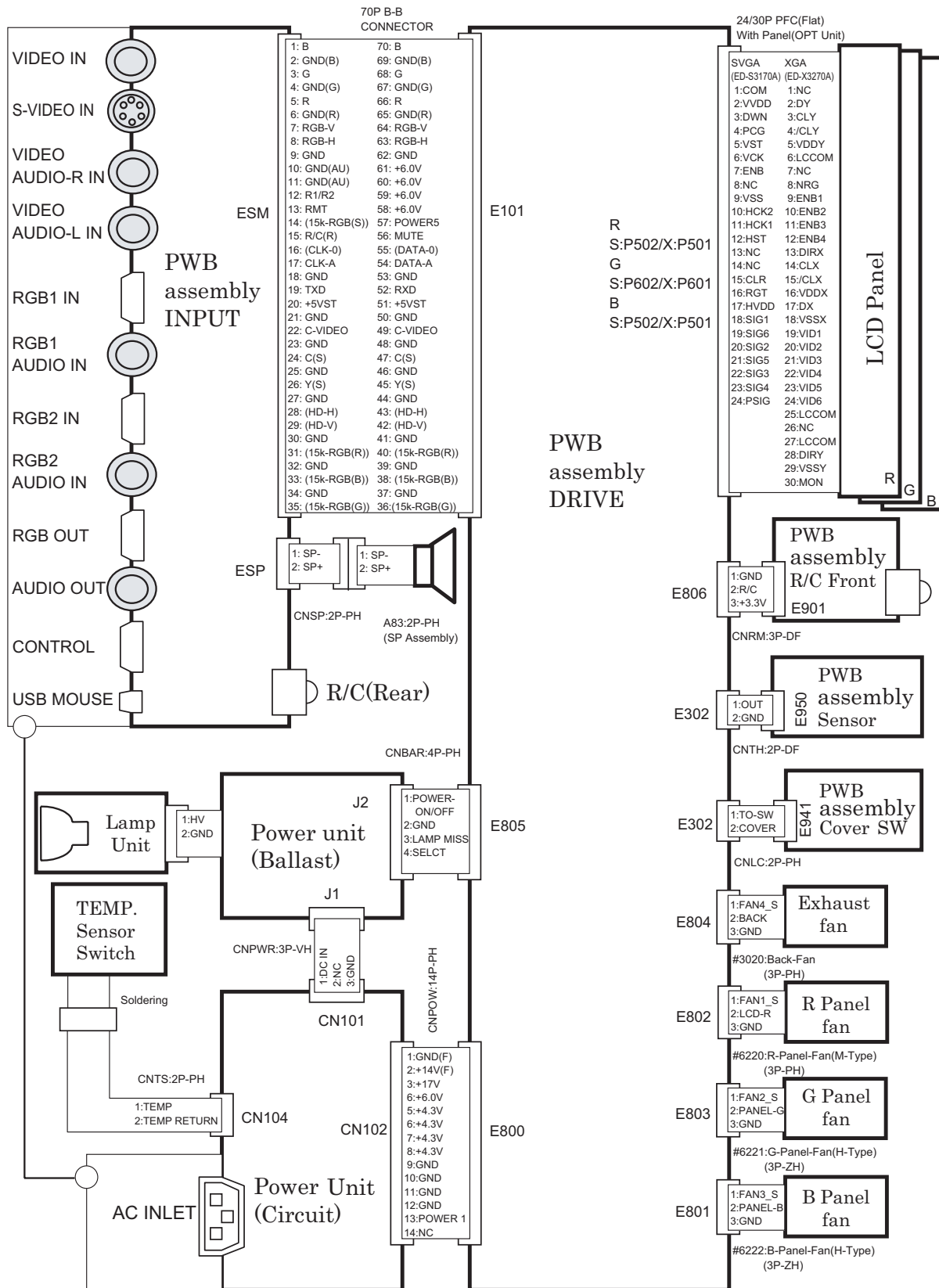

Connector connection diagram (C3S3E/C3XM3E)

Wiring for Circuit Power Supply and Ballast Power Supply Boards

Wiring for Circuit Power Supply Board

- (1) Keep a record of the circuit power supply lot number in the 100% inspection record.
- (2) Connect the TSW.
- (3) Install the FEB3.
- (4) Connect the CNPOW.
- (5) Connect the CNTH.
- (6) Apply the TAP3.

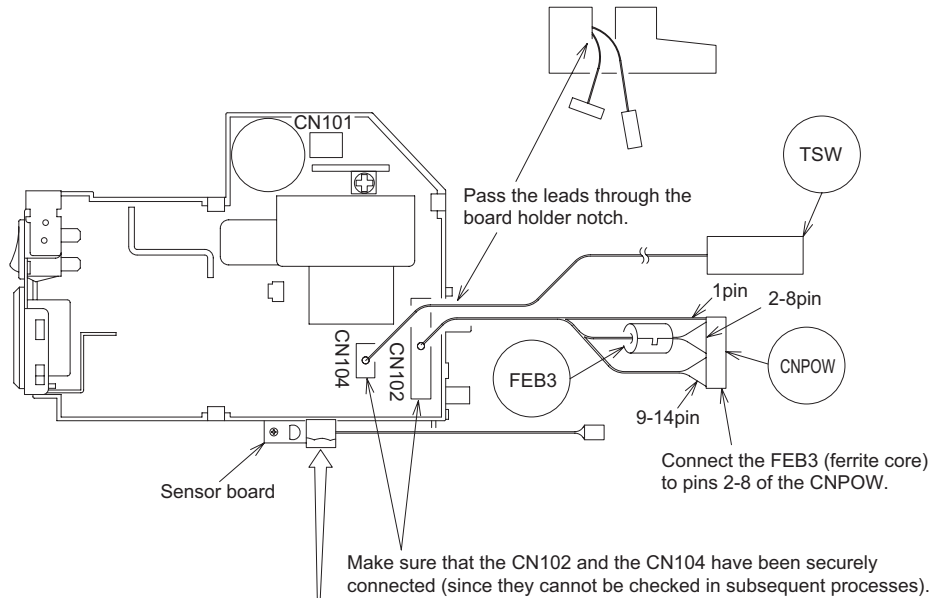

Install the sensor board after completing the following steps:

Connect the CNTH to connector E950 on the sensor board.

E950

Sensor board

CNTH

Make sure that connector E950 has been securely connected then apply the TAP3 (to prevent detachment).

TAP3

Wiring for Ballast Power Supply Board

- (1) Keep a record of the ballast power supply lot number in the 100% inspection record.
- (2) Cut off the PVC sheet.
- (3) Connect the CNPWR.
- (4) Install the FEB2.
- (5) Connect the CNBAR.
- (6) Install the ballast shield (in accordance with the general assembly drawing).

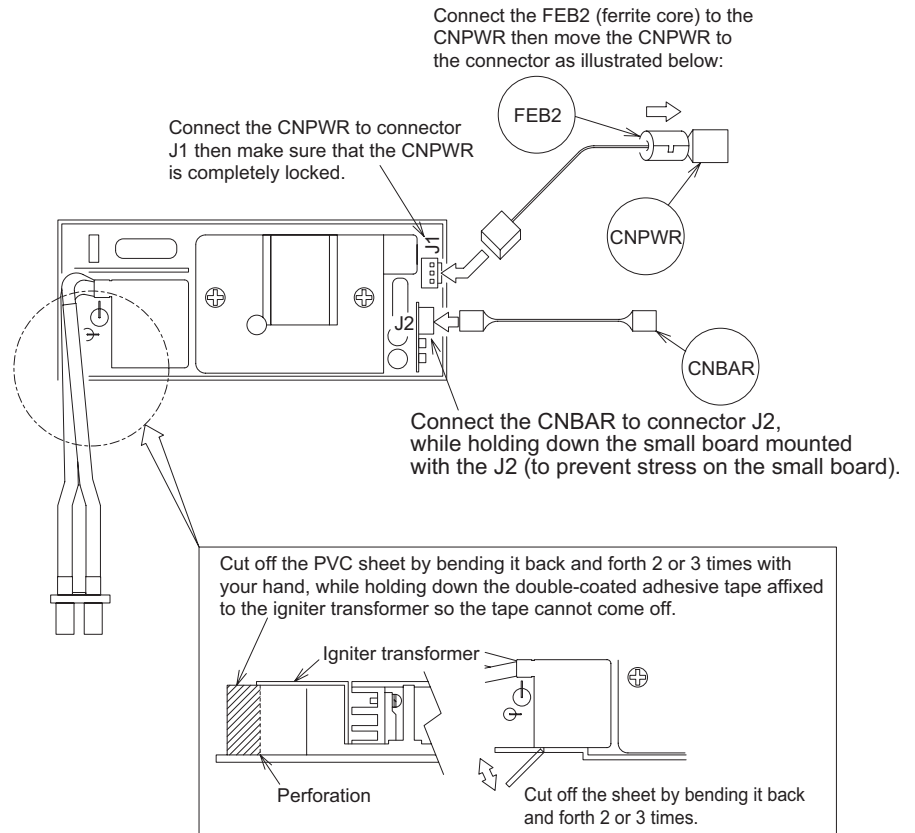

Wiring for Power Supply (for Board Sub-assembly)

During power supply assembling

- (1) Wire and connect the CNPWR.
- (2) Lay the lamp leads.
- (3) Apply the TAP6.
- (4) Hook the CNTH lead and apply the TAP10.

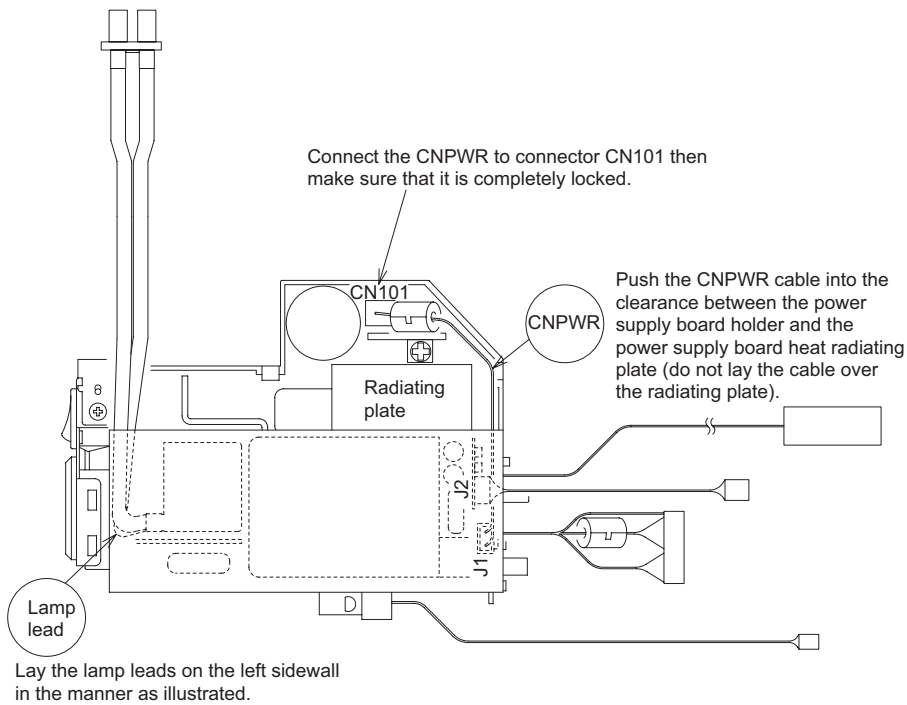

Apply the TAP6 to the specified position on the lamp leads shown in the illustration.

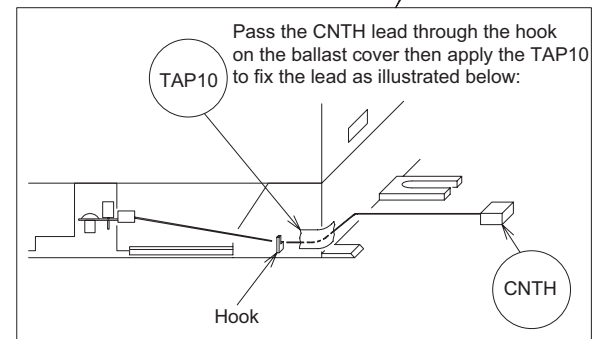
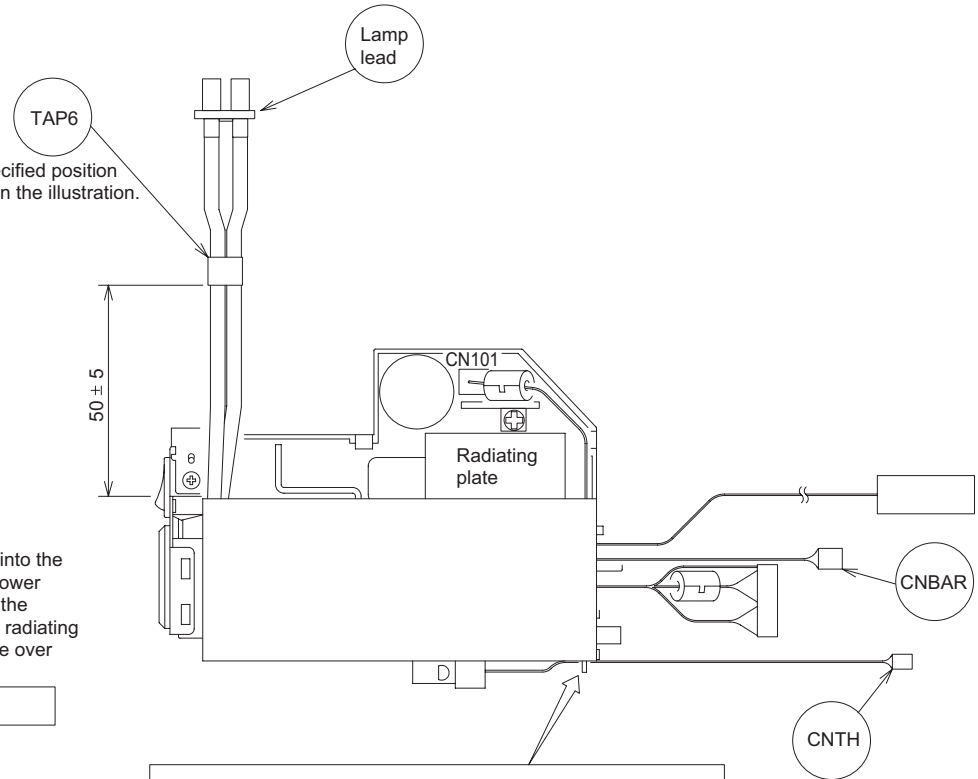

Wiring for Bottom Case Assembling

Before installing the optical unit, put all of leads away from where the optical unit is installed as illustrated below so no lead can become entangled.

- During bottom case assembling
- (1) Connect the CNSP to the A83.
 - (2) Take care not to entangle any lead when installing the optical unit.

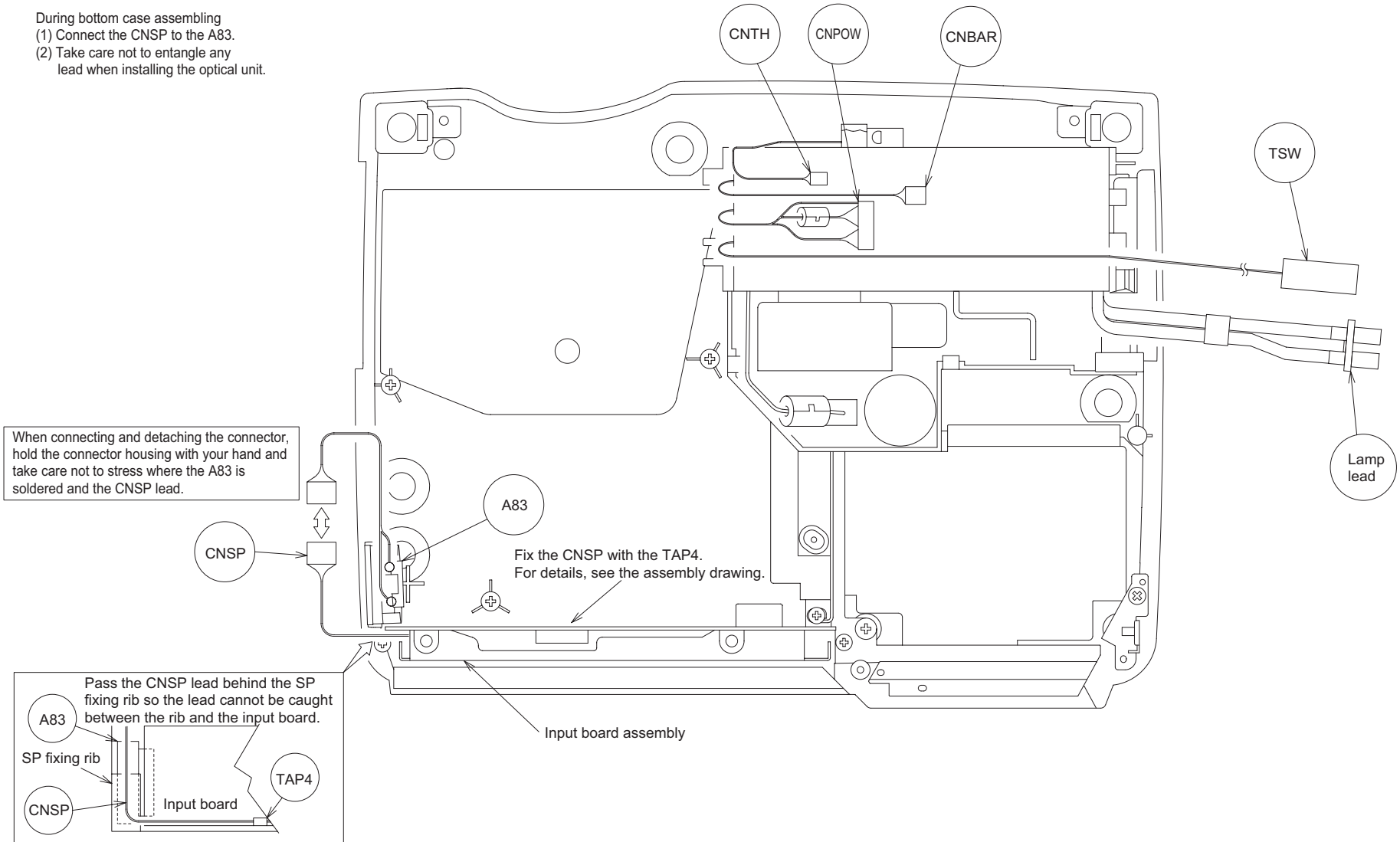

Wiring for Optical Unit Installation

- During optical unit installation
- (1) Connect the CNRM.
 - (2) Apply the TAP1.
 - (3) Connect the CNLC.
 - (4) Connect the lamp leads.
 - (5) Lay the SP lead (A83-CNSP).

Pass the CNRM through the specified position as illustrated and avoid passing it between the boss and the lens barrel (to prevent the lens from contacting the cable).

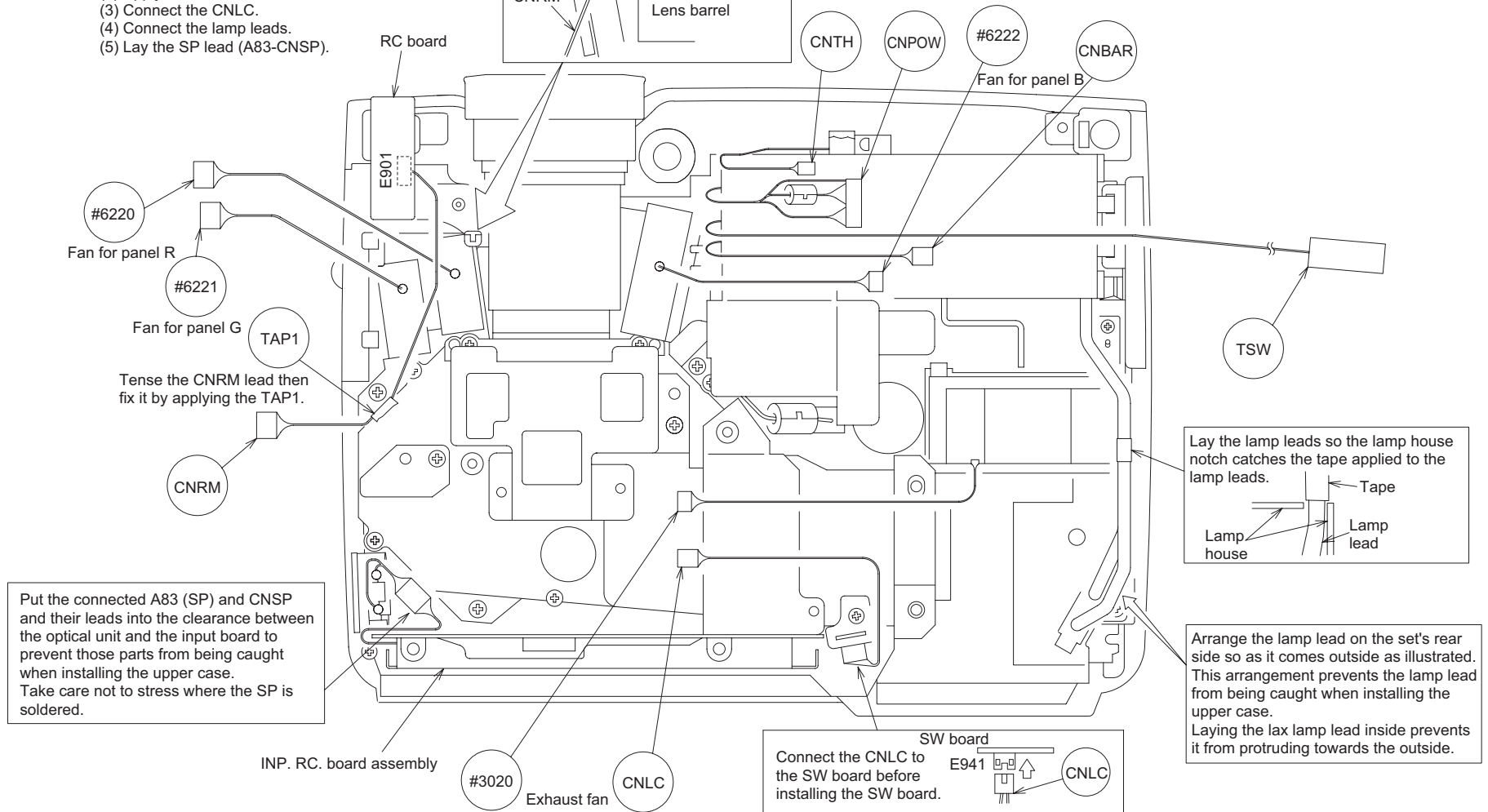
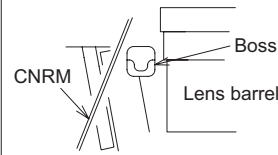

Put the connected A83 (SP) and CNSP and their leads into the clearance between the optical unit and the input board to prevent those parts from being caught when installing the upper case. Take care not to stress where the SP is soldered.

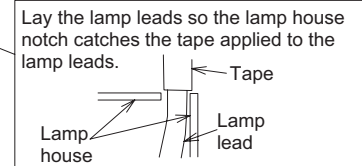

Arrange the lamp lead on the set's rear side so as it comes outside as illustrated. This arrangement prevents the lamp lead from being caught when installing the upper case. Laying the lax lamp lead inside prevents it from protruding towards the outside.

Wiring before Drive Board Installation

Before drive board installation

- (1) Wire the CNBAR.
- (2) Wire and install the TSW.
- (3) Lay and fix the lamp leads.
- (4) Lay the #3020 lead.
- (5) Wire the TSW.
- (6) Apply the TAP7.

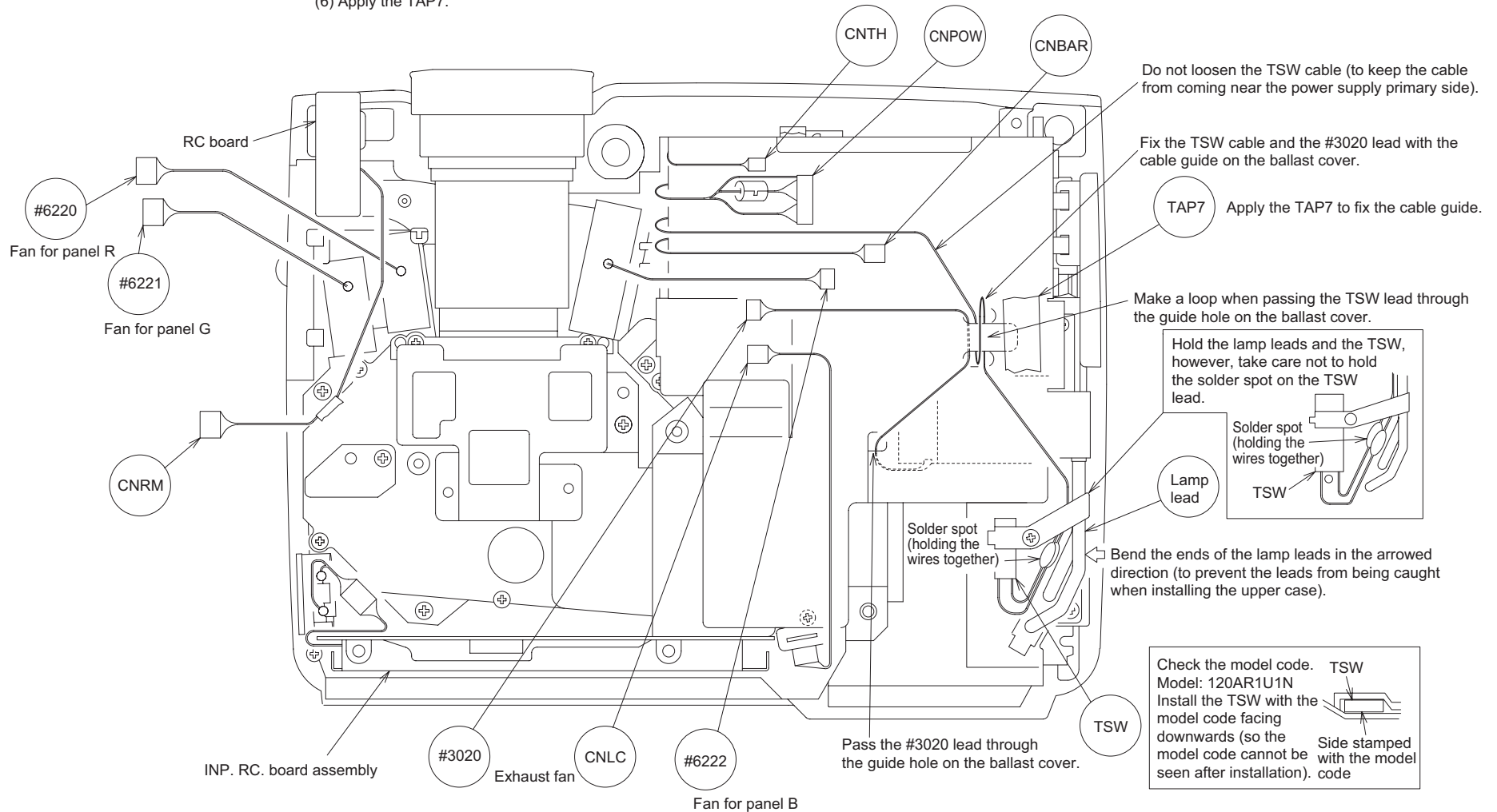

Wiring for Drive Board Installation

Procedure

- (1) Before installing the drive board, connect the CNBAR and the #6222 while holding the drive board with your hand.
- (2) Put the drive board in the position where you install it then connect the CNTH, the CNPOW, the #6220 and the #6221 while lifting the rear of the board.
- (3) Connect the CNRM, the CNLC, the #3020 and the panel flexible cable.

During drive board installation

- (1) Connect the CNTH, the CNPOW, the #6220 and the #6221.
- (2) Wire and connect the CNBAR and the #6222.
- (3) Connect the CNRM, the CNLC and the #3020.
- (4) Apply the TAP2.
- (5) Connect the flexible cable for the liquid crystal panel.
- (6) Take care not to entangle the lamp leads when installing the upper case.

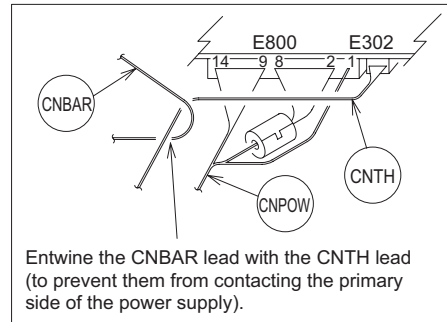

Pass the #6222 lead over the ballast cover (if the lead is passed from the side of the ballast power supply, it will contact the power supply primary side).

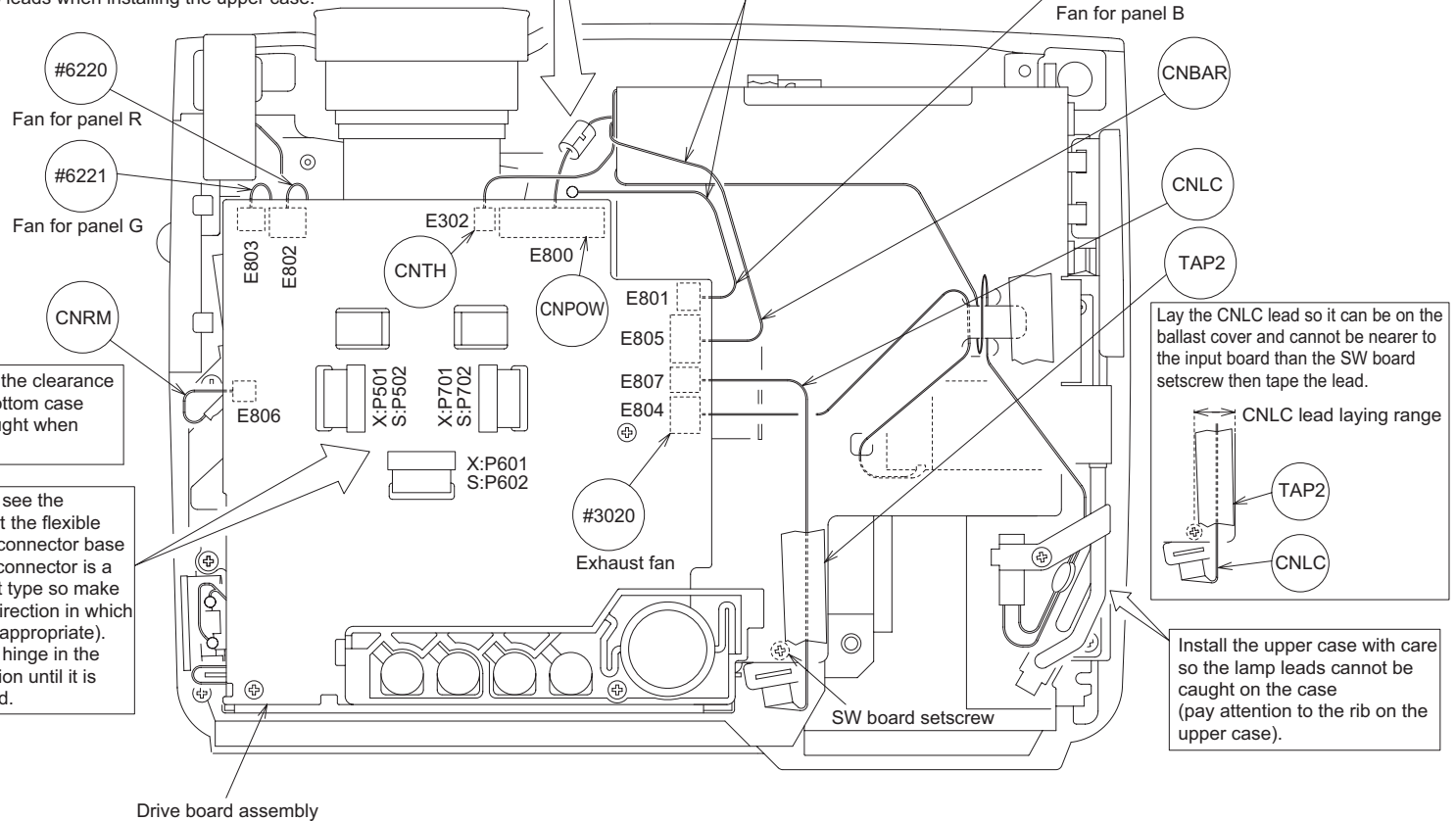

10. Basic circuit diagram

Parts with hatching are not mounted.

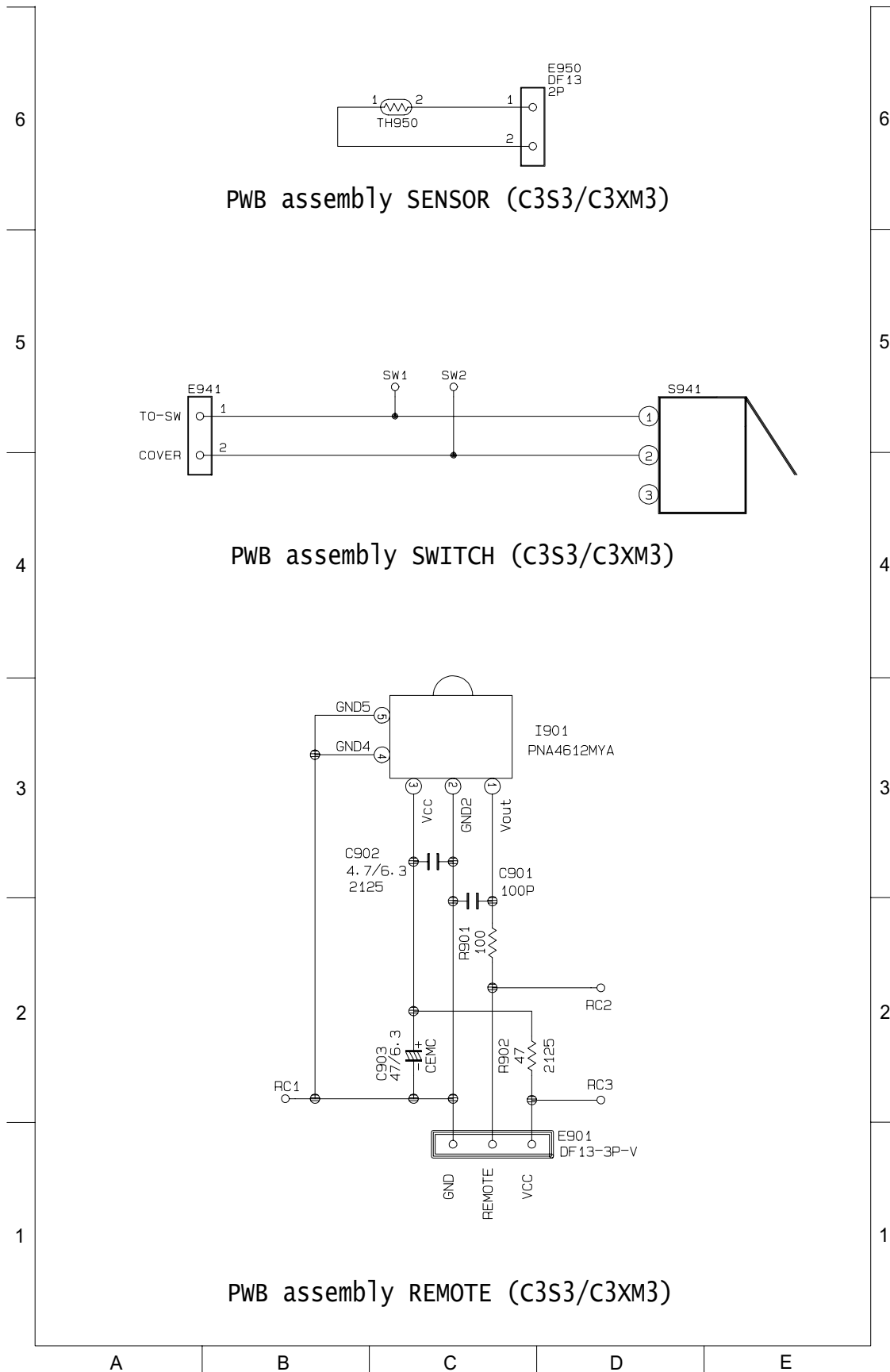

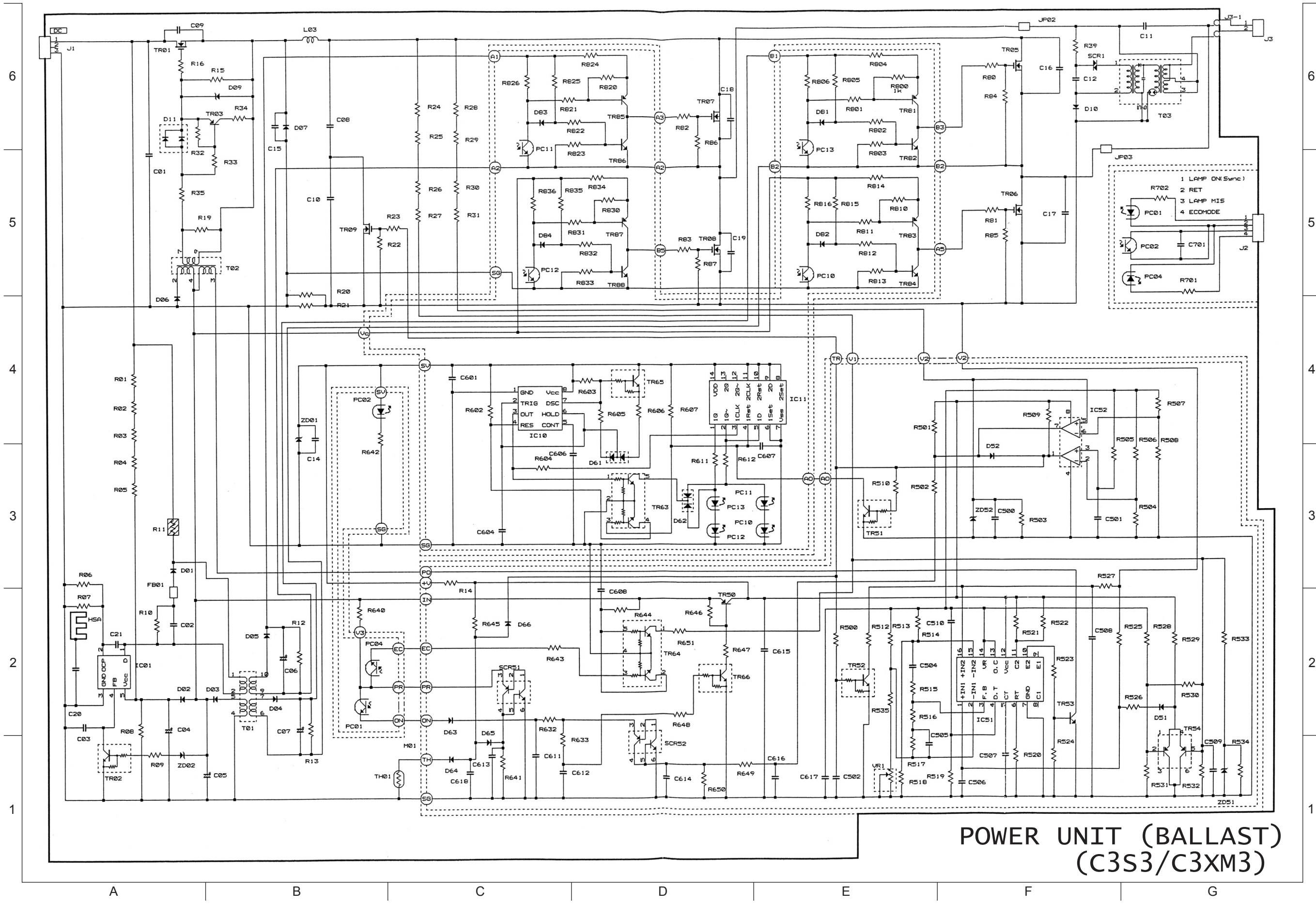

**POWER UNIT (BALLAST)
(C3S3/C3XM3)**

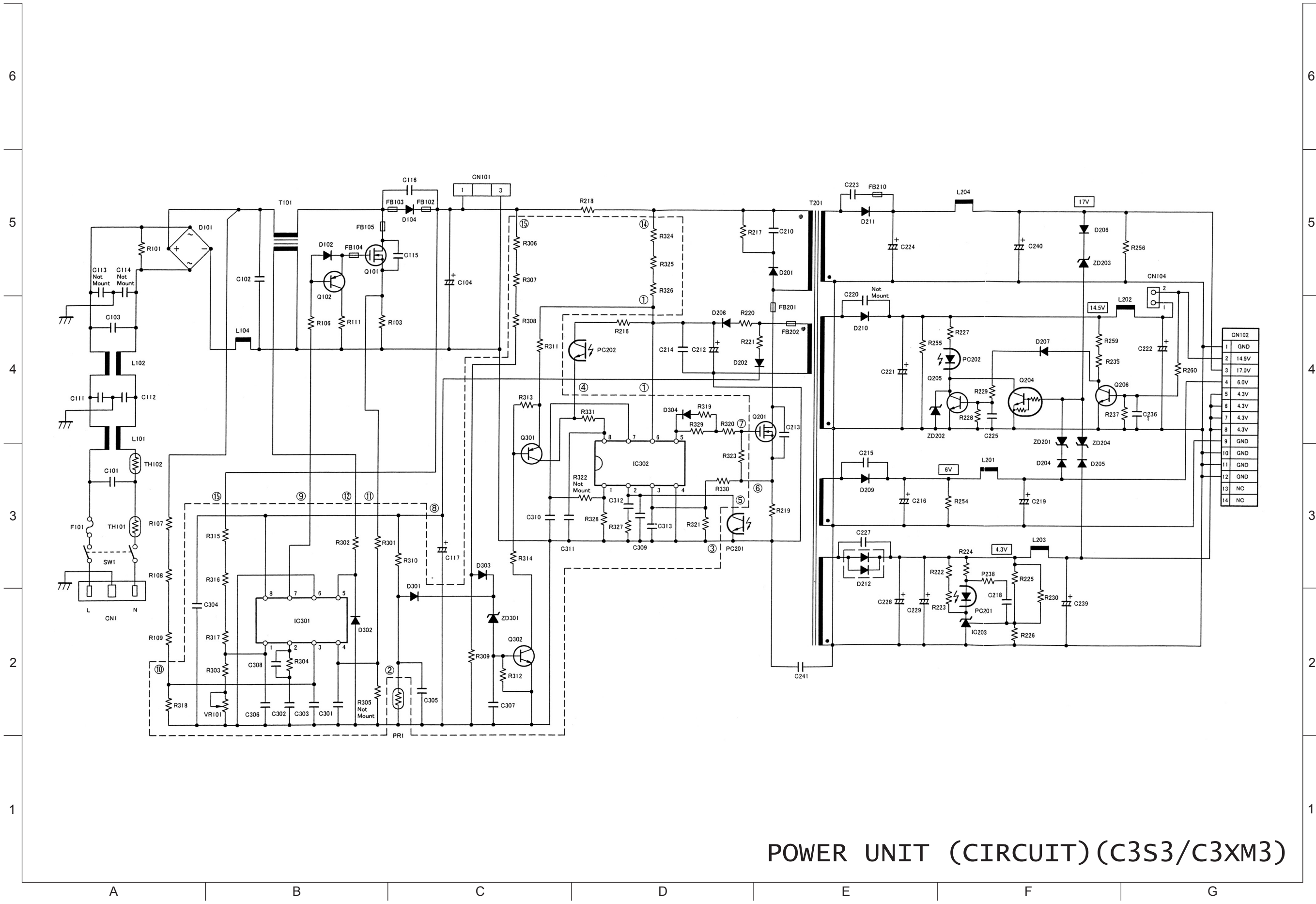

POWER UNIT (CIRCUIT) (C3S3/C3XM3)

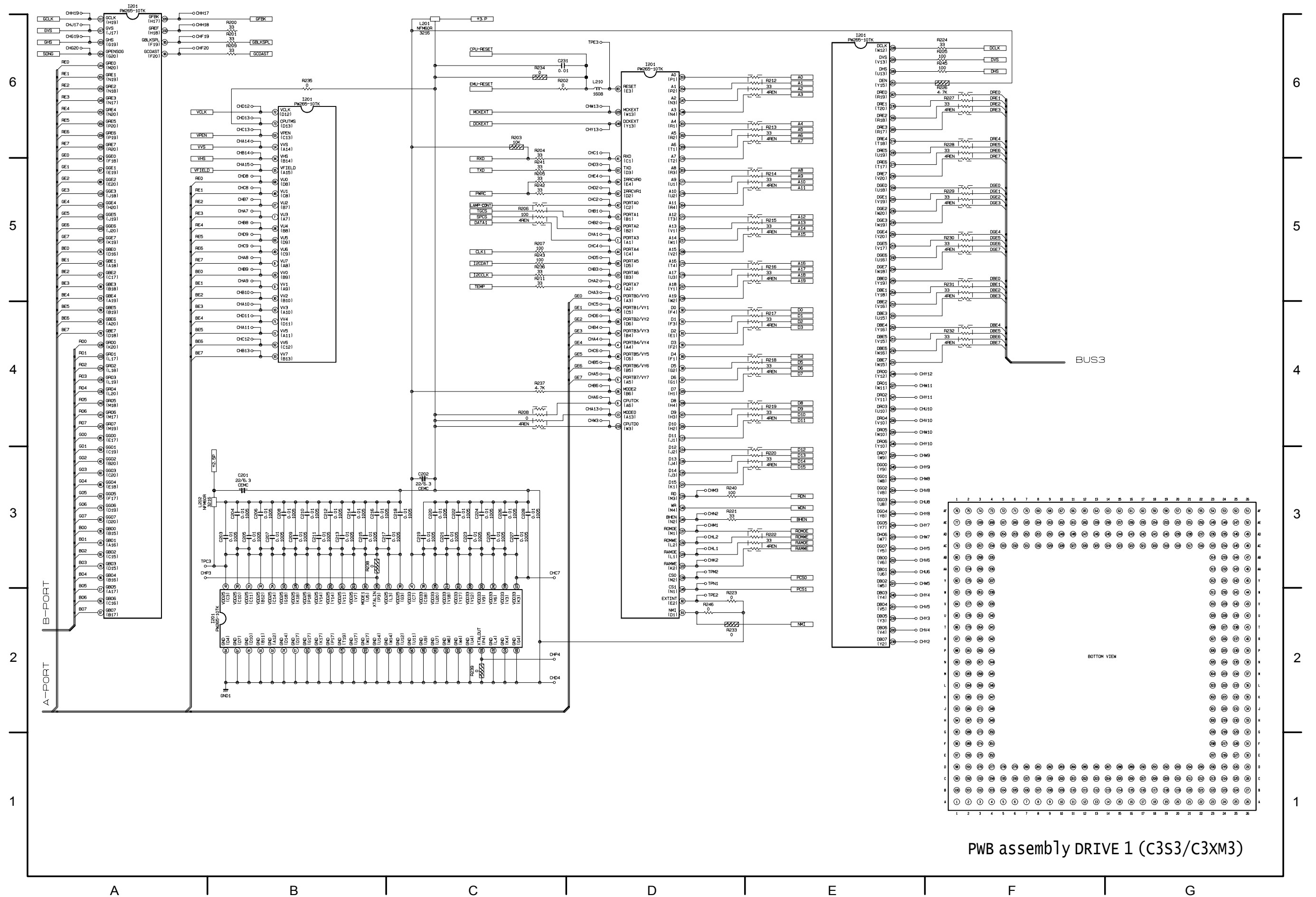

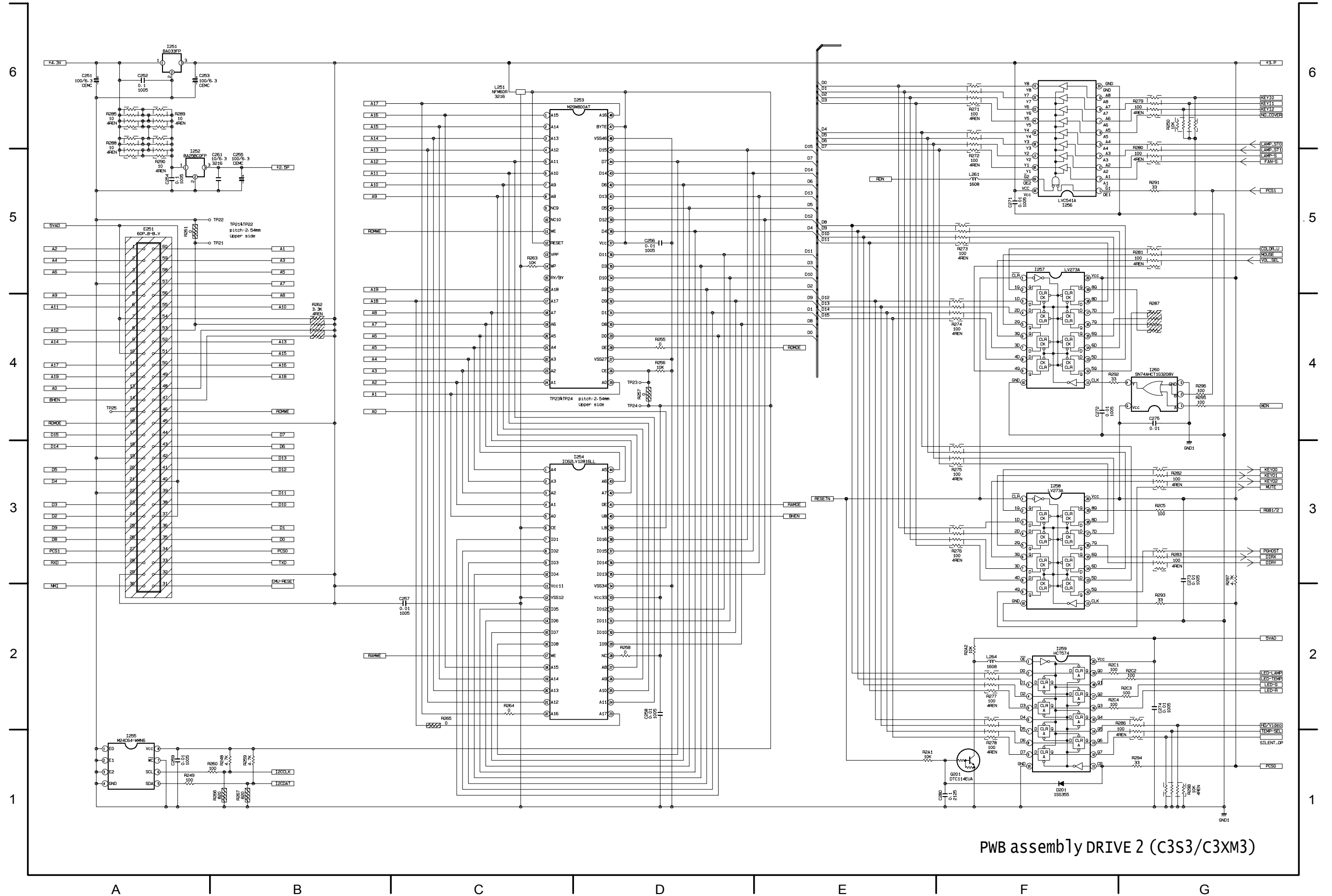

PWB assembly DRIVE 2 (C3S3/C3XM3)

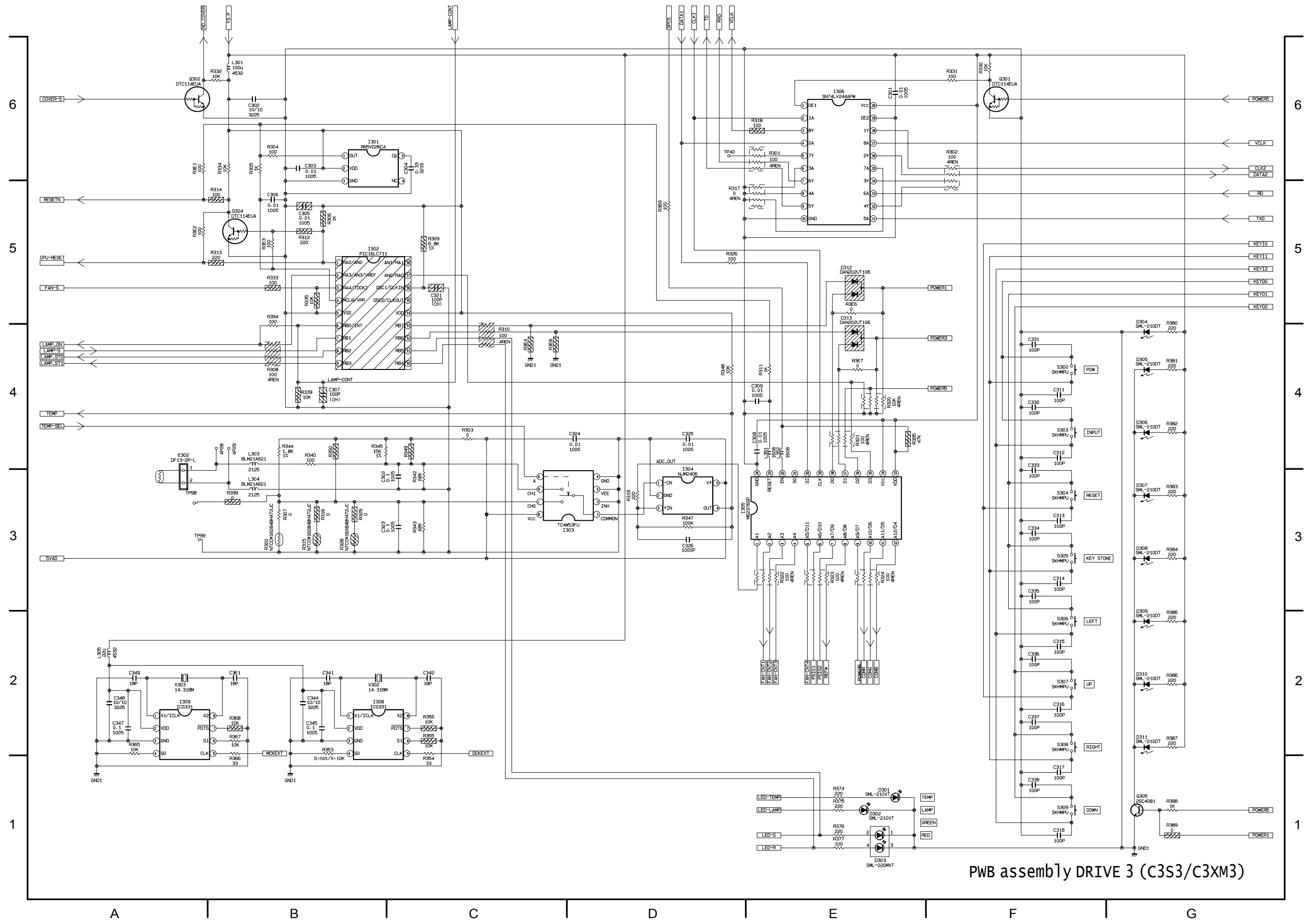

PWB assembly DRIVE 3 (C3S3/C3XM3)

6

5

4

3

2

1

6

5

4

3

2

1

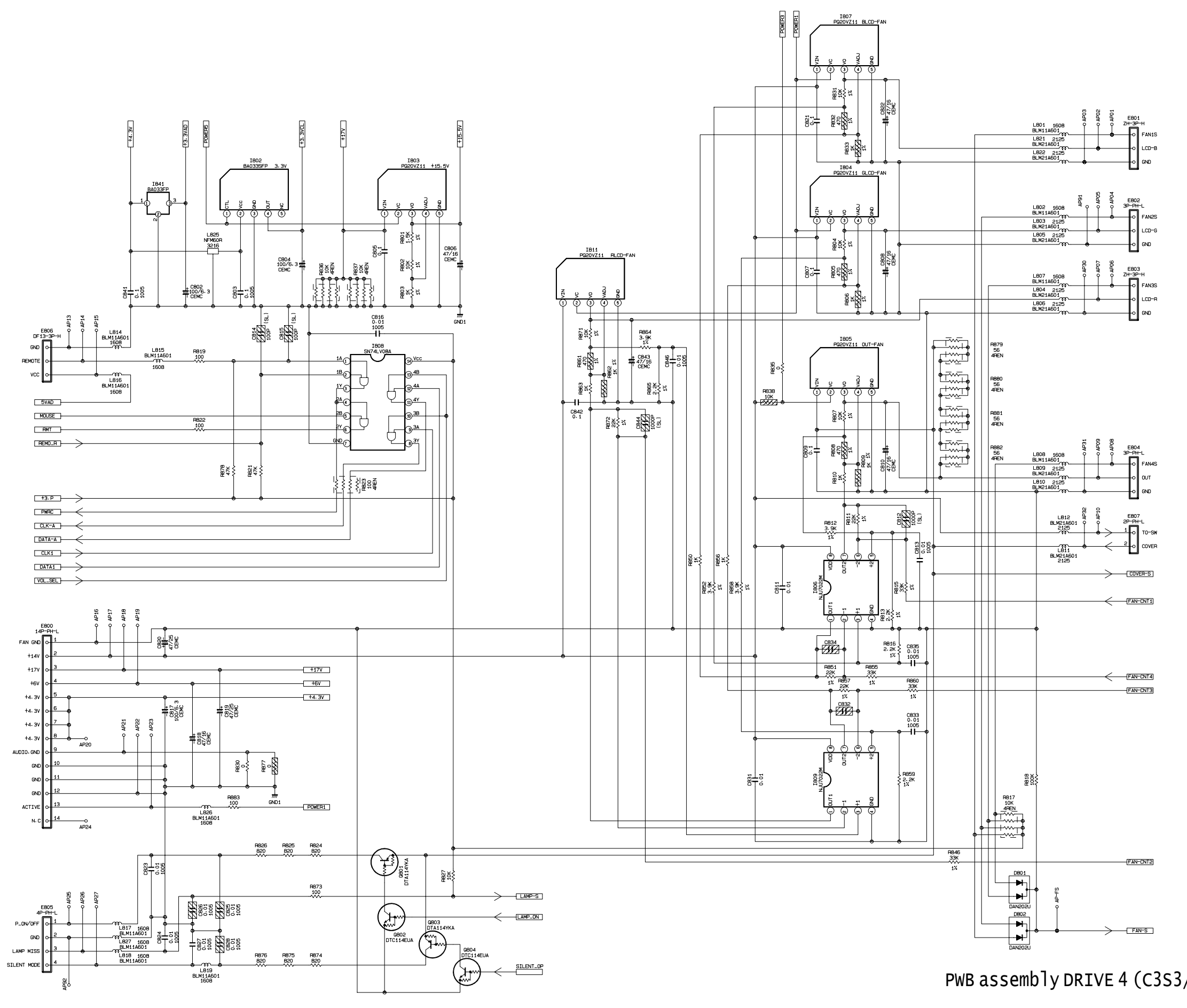

PWB assembly DRIVE 4 (C3S3/C3XM3)

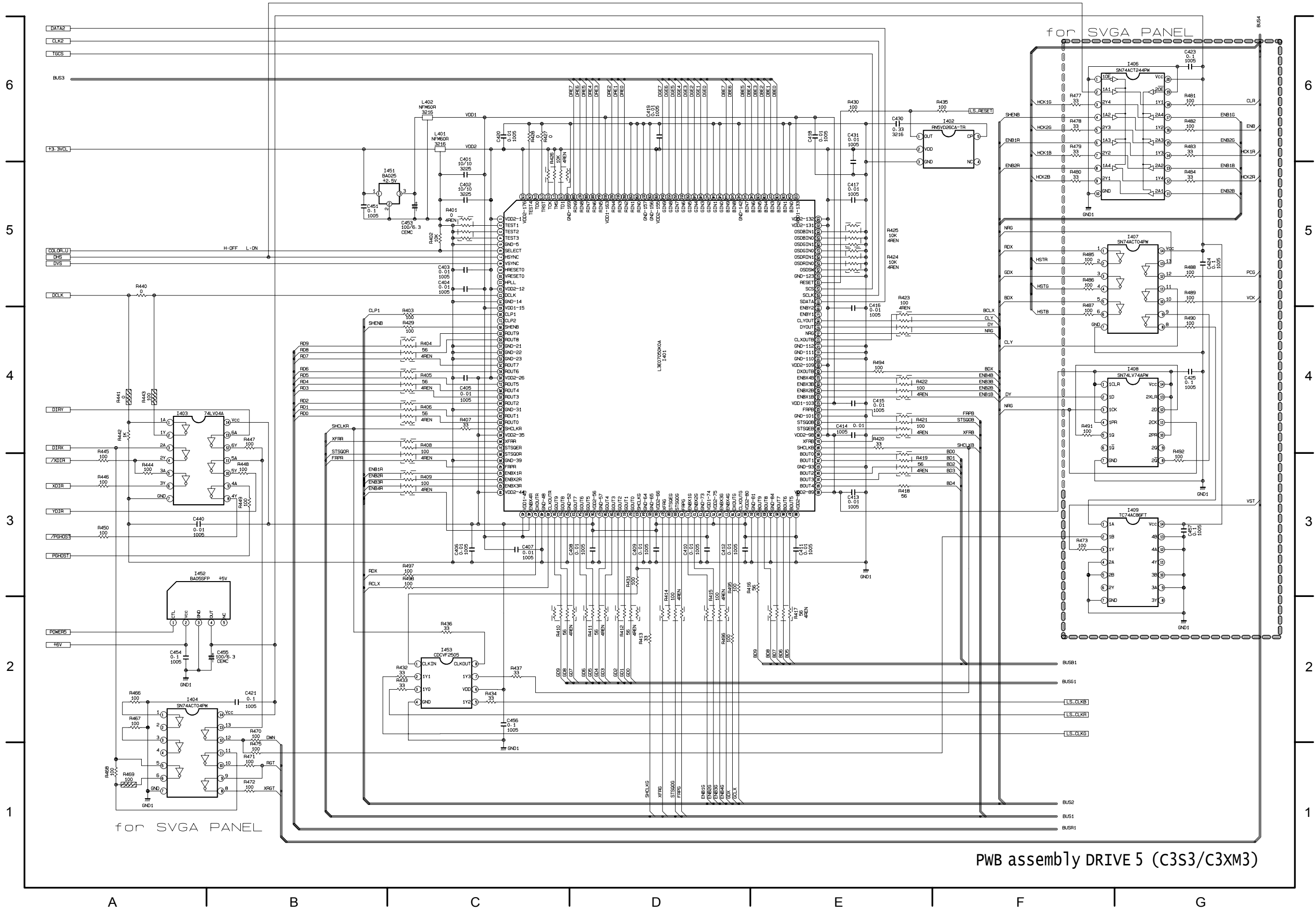

PWB assembly DRIVE 5 (C3S3/C3XM3)

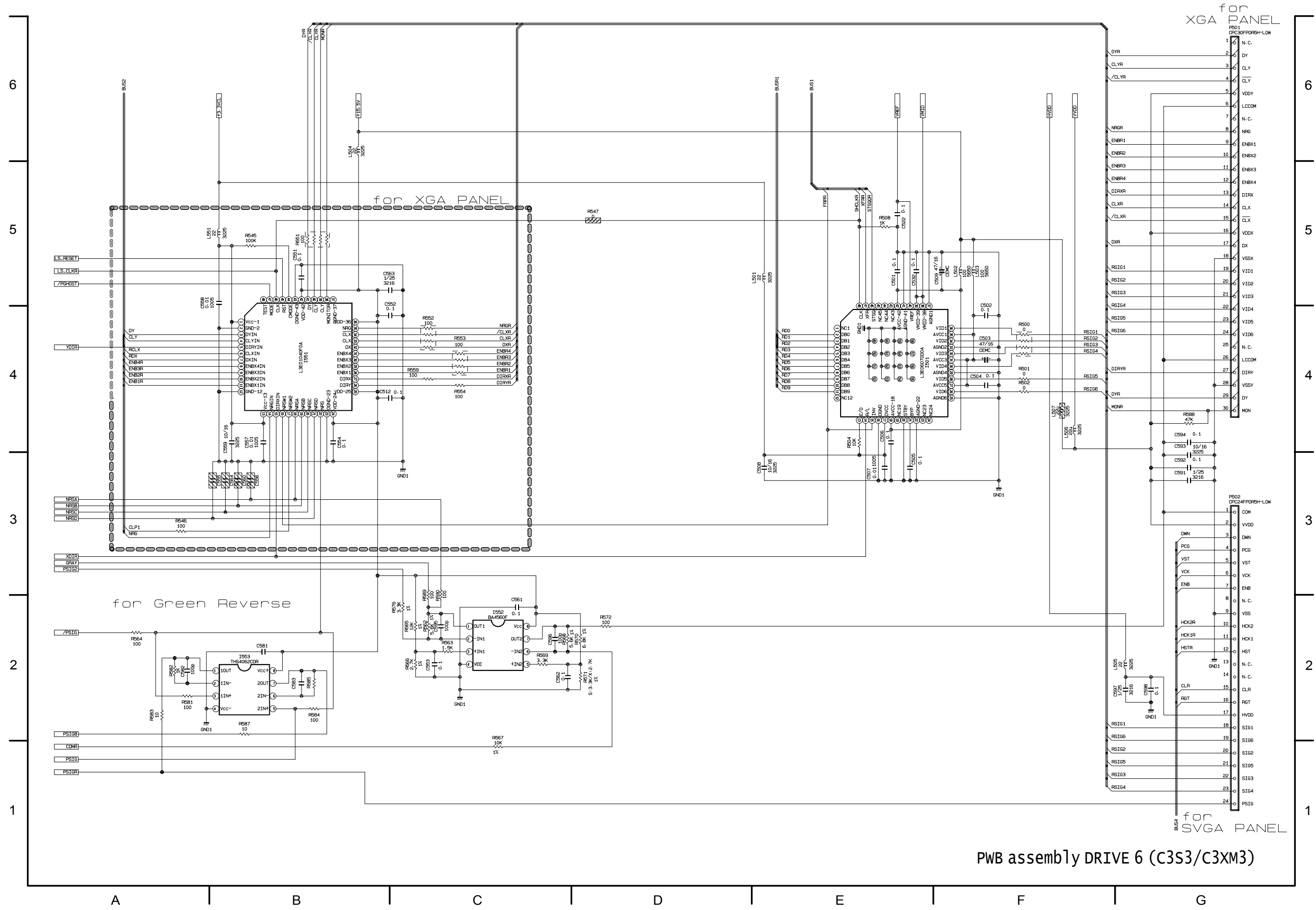

PWB assembly DRIVE 6 (C3S3/C3XM3)

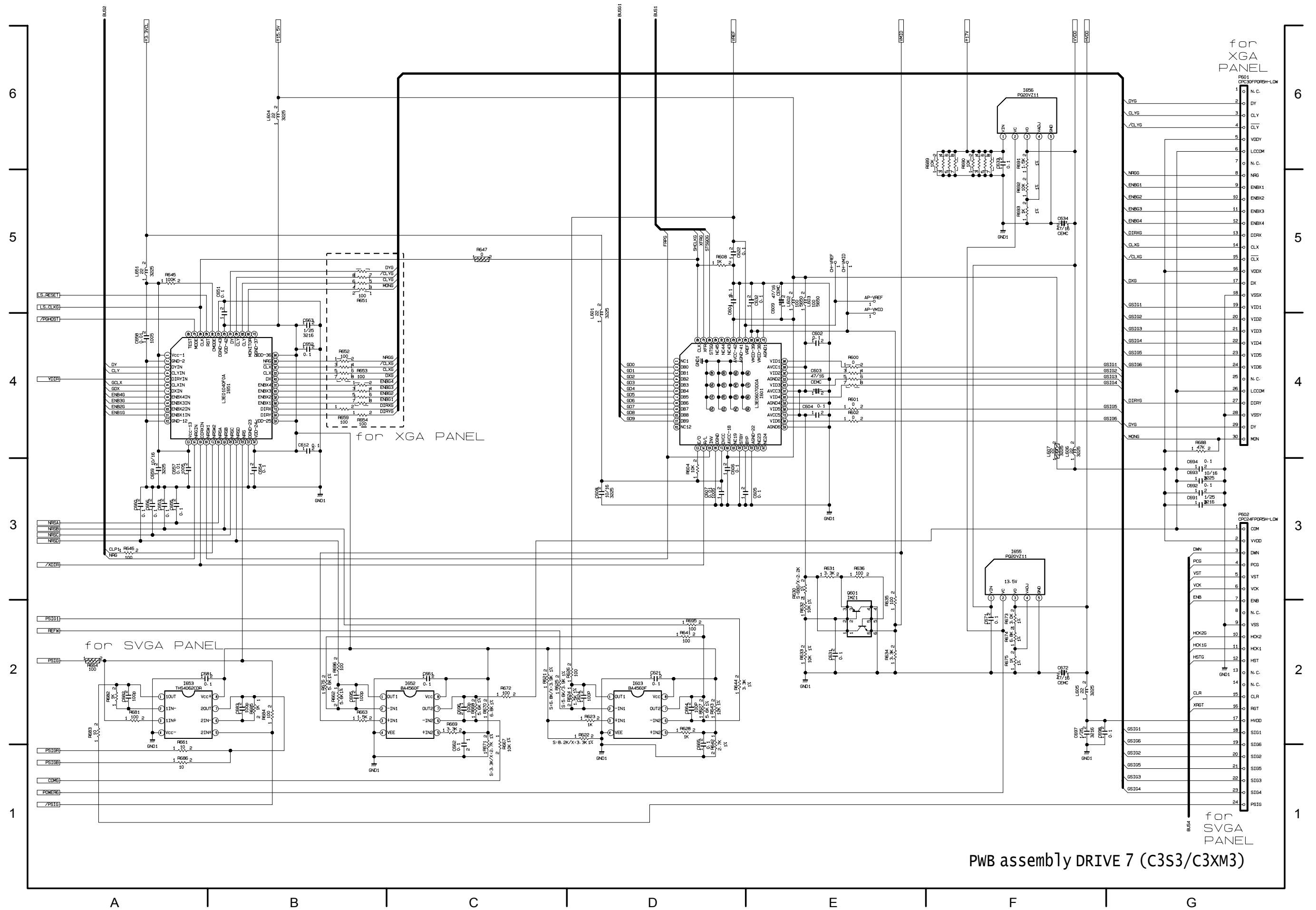

PWB assembly DRIVE 7 (C3S3/C3XM3)

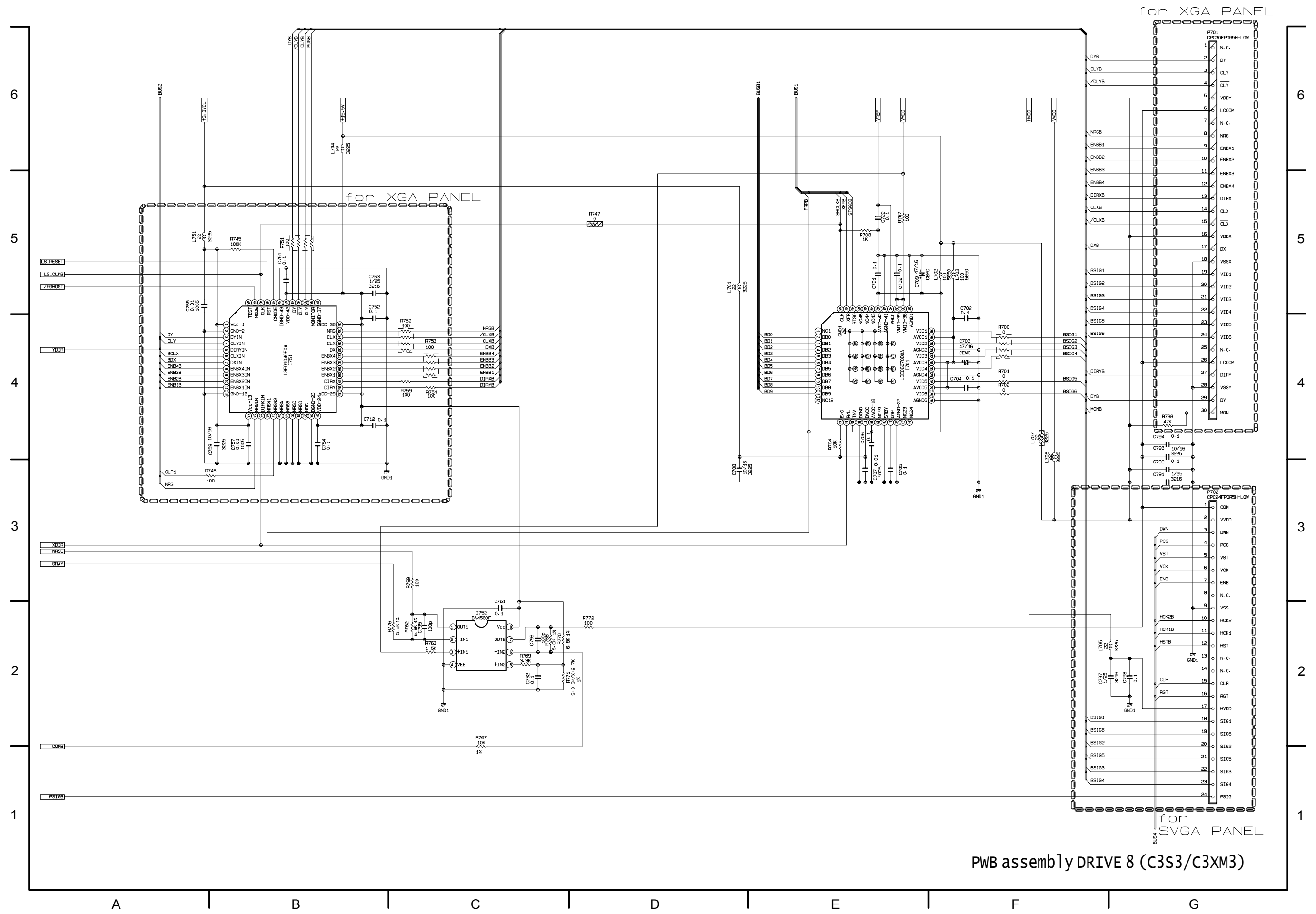

PWB assembly DRIVE 8 (C3S3/C3XM3)

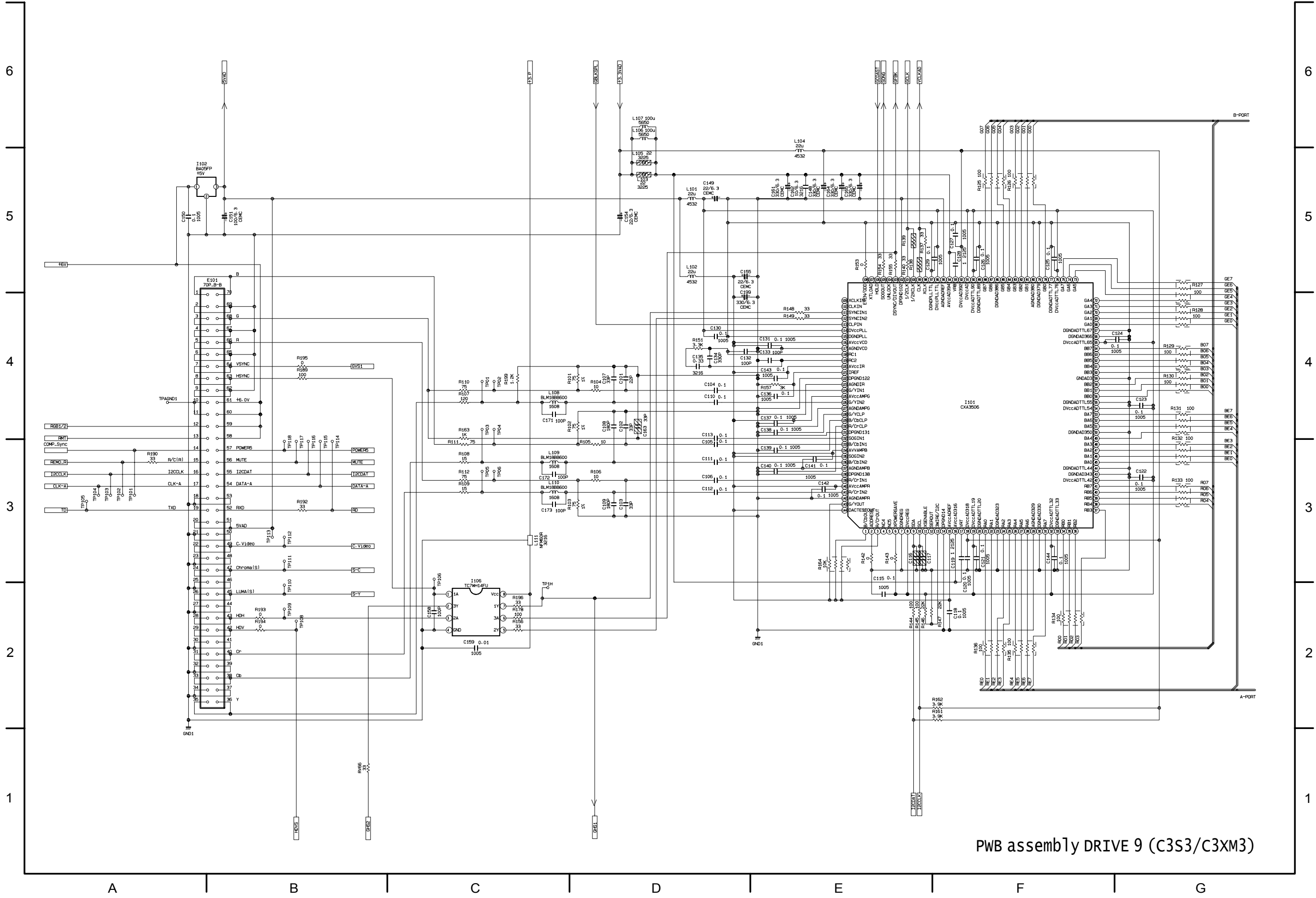

PWB assembly DRIVE 9 (C3S3/C3XM3)

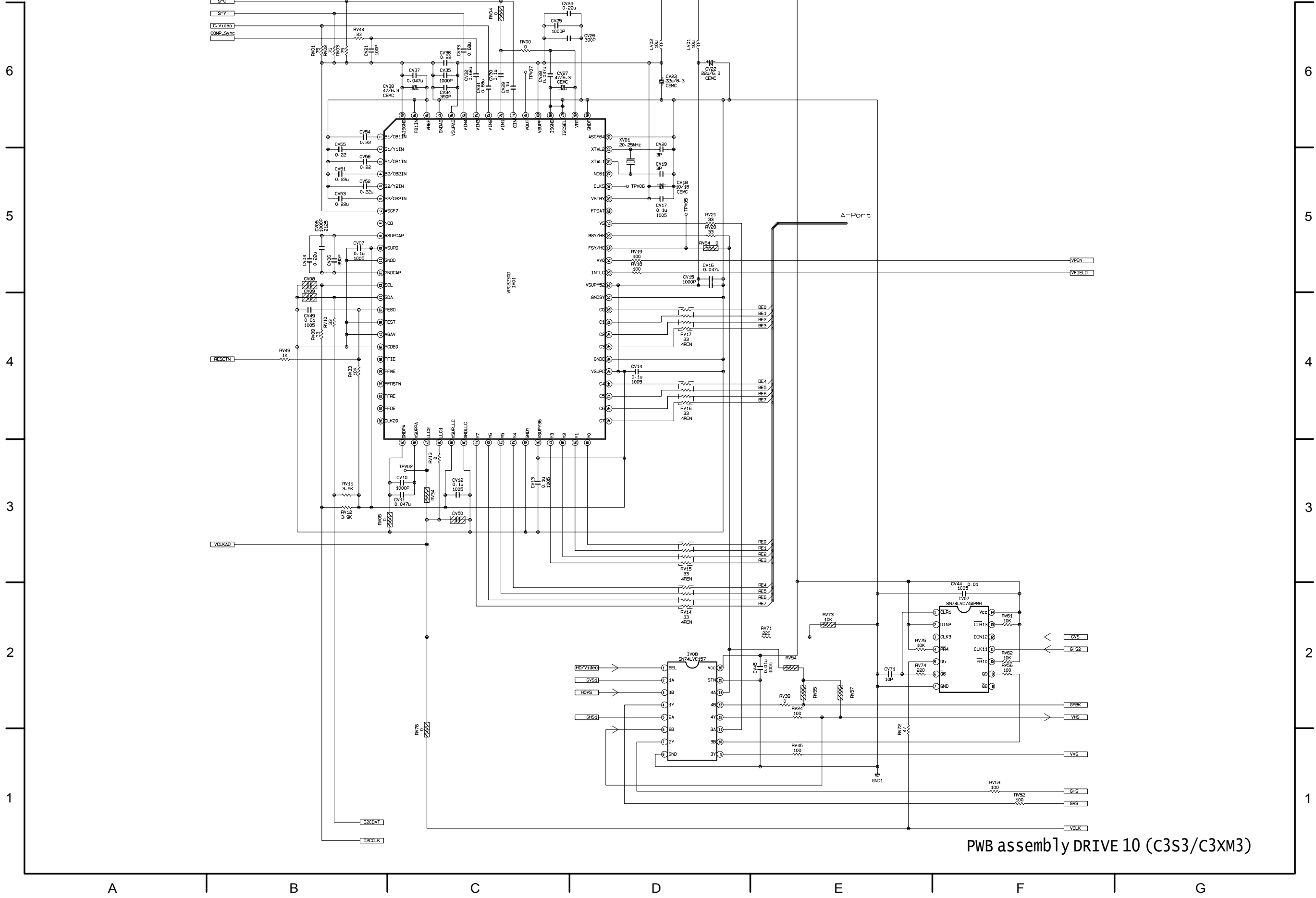

PWB assembly DRIVE 10 (C3S3/C3XM3)

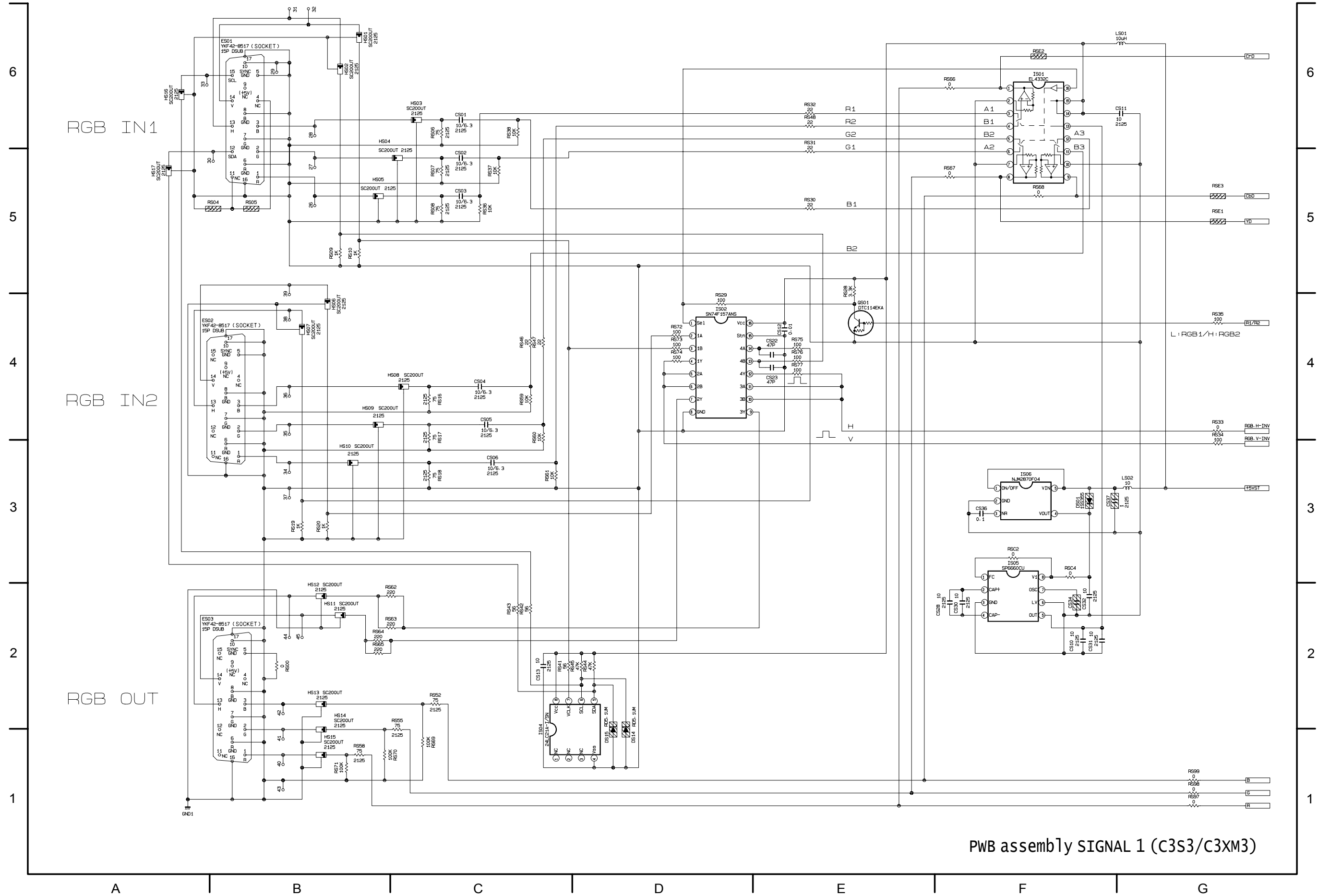

PWB assembly SIGNAL 1 (C3S3/C3XM3)

6

5

4

3

2

1

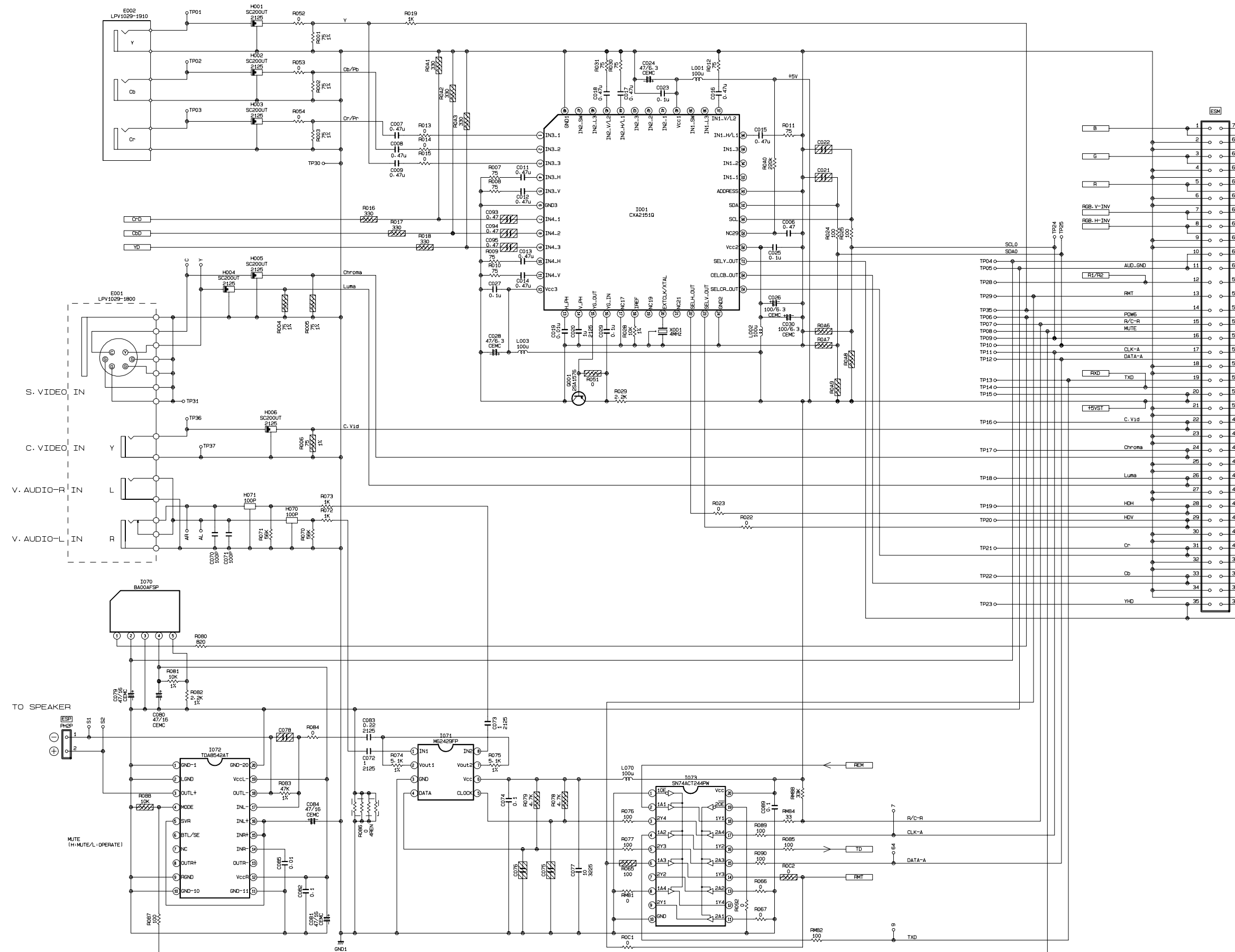

6

5

4

3

2

1

PWB assembly SIGNAL 2 (C3S3/C3XM3)

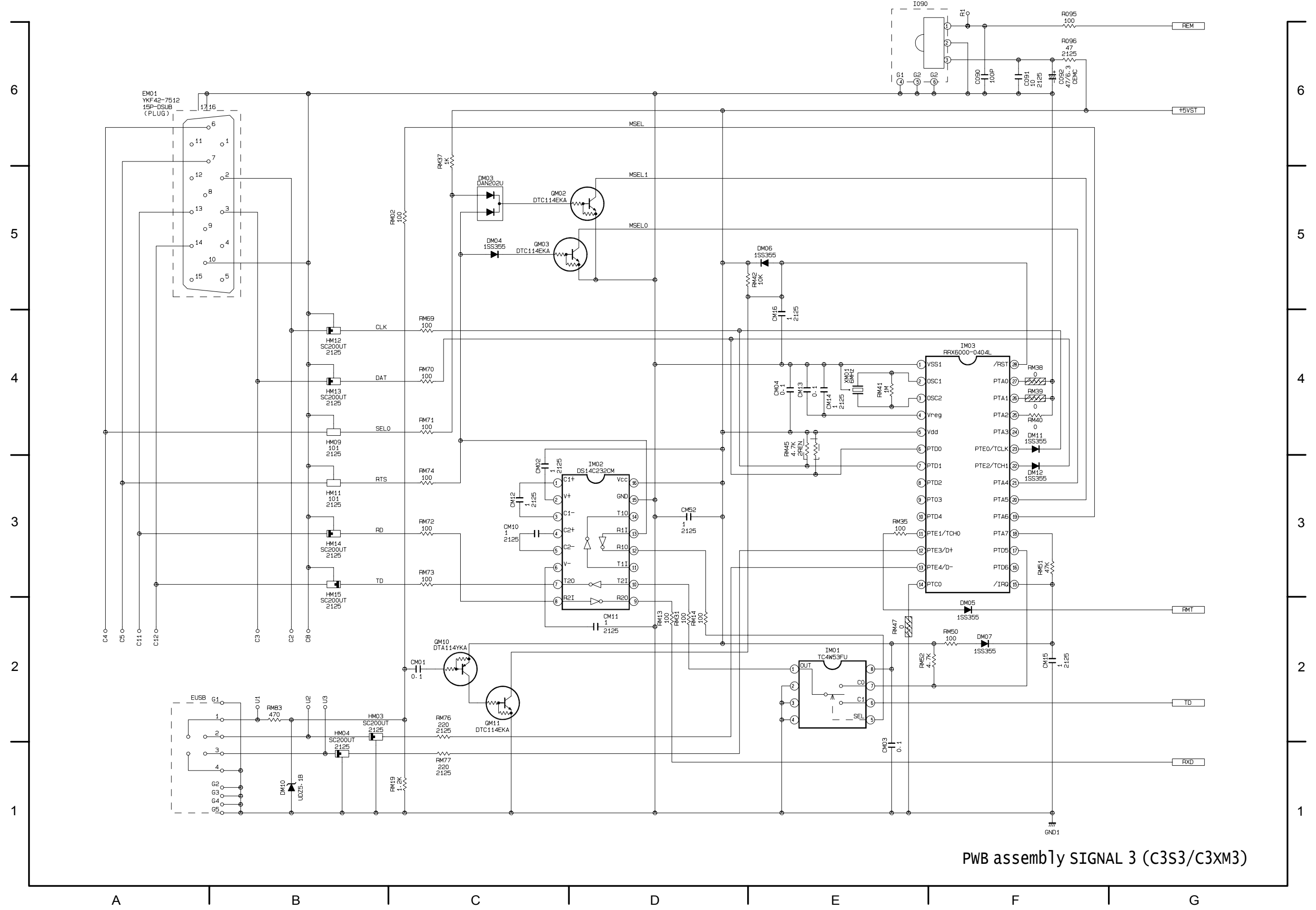

PWB assembly SIGNAL 3 (C3S3/C3XM3)

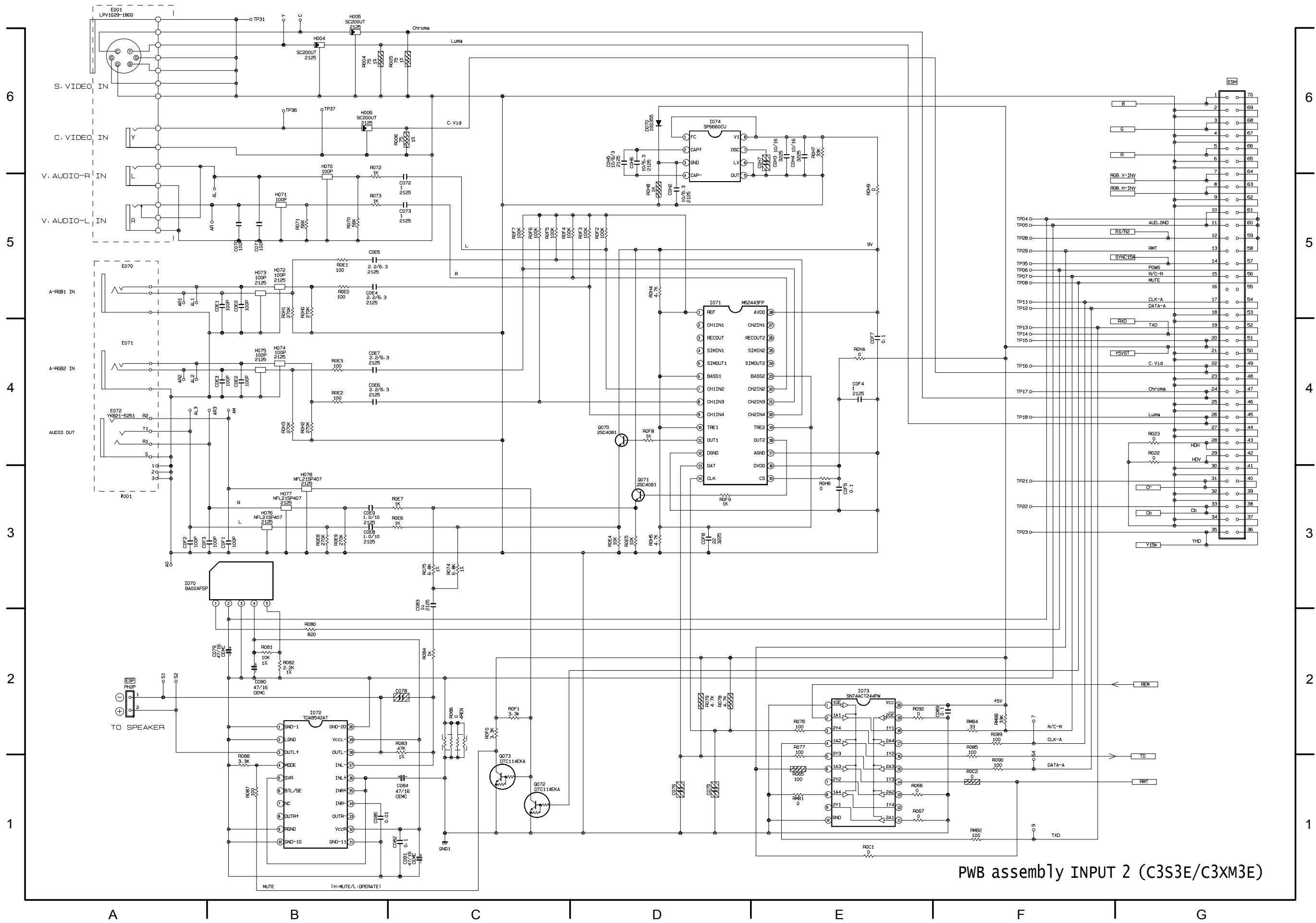

PWB assembly INPUT 2 (C3S3E/C3XM3E)

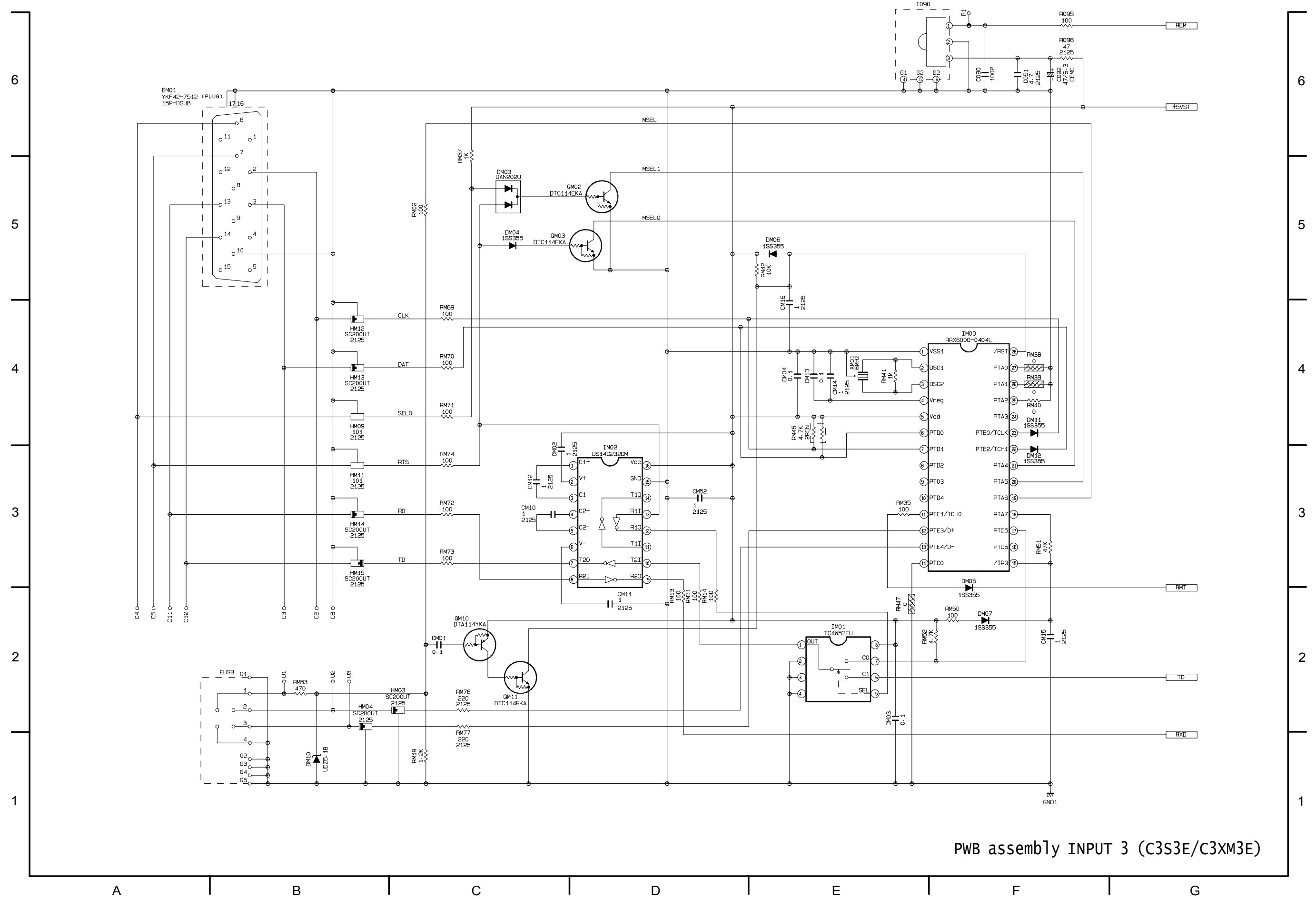

PWB assembly INPUT 3 (C3S3E/C3XM3E)

11. Disassembly diagram

M : Meter screw
T : Tapping screw

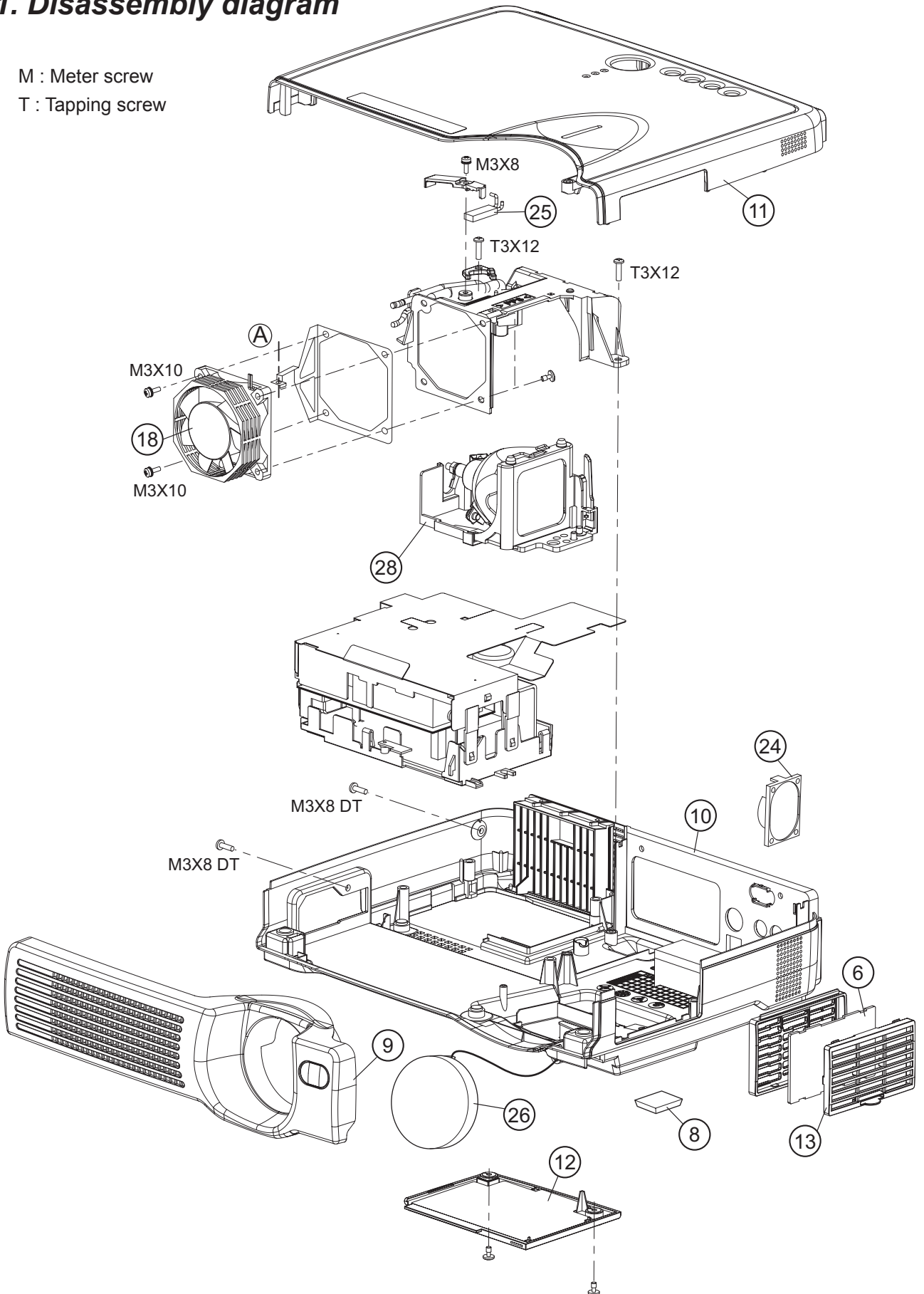

M : Meter screw
 T : Tapping screw

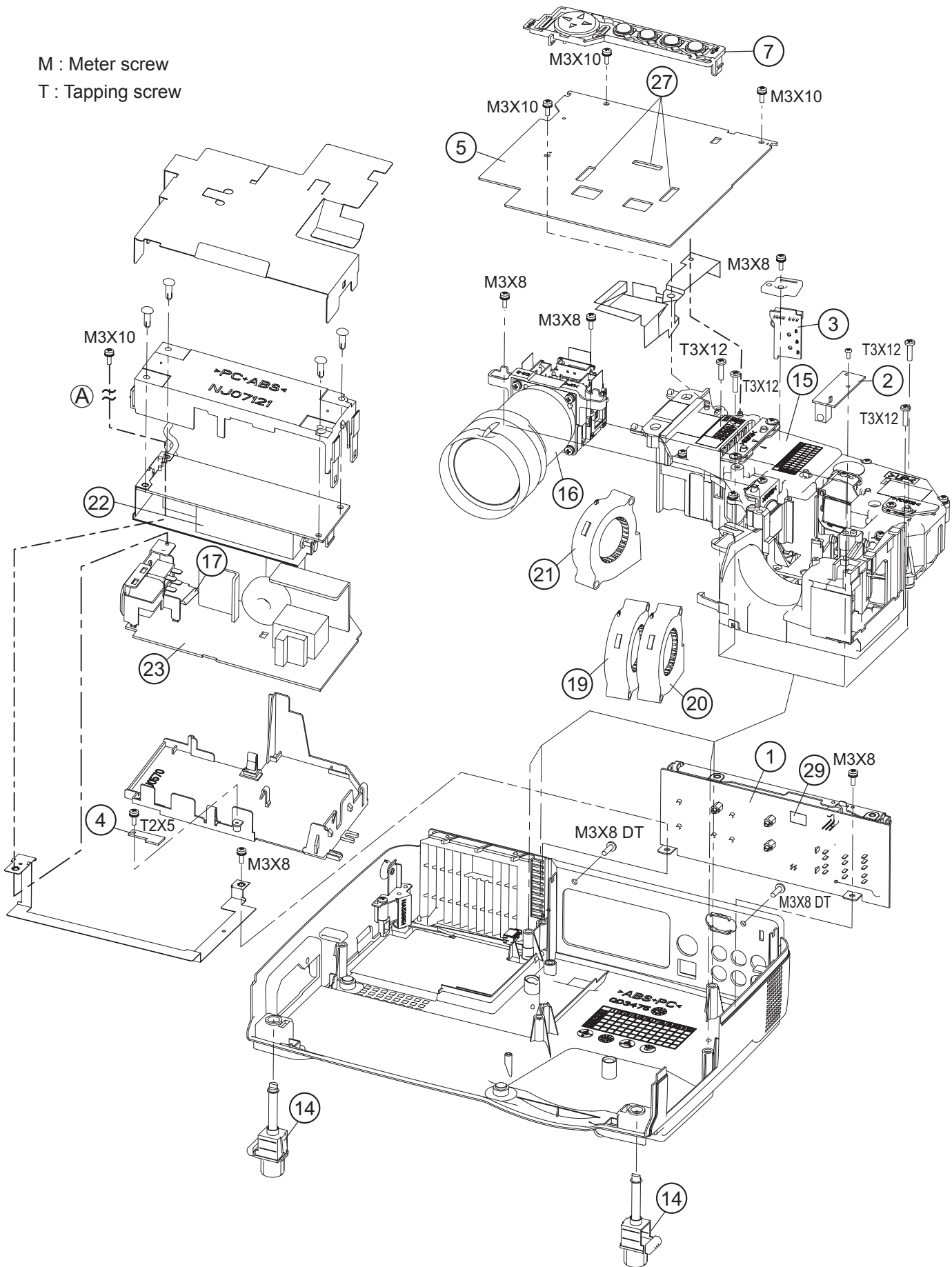

**THE UPDATED PARTS LIST
FOR THIS MODEL IS
AVAILABLE ON ESTA**

13. RS-232C communication

- (1) Turn off the projector and computer power supplies and connect with the RS-232C cable.
- (2) Turn on the computer power supply and after the computer has started up, turn on the projector power supply.

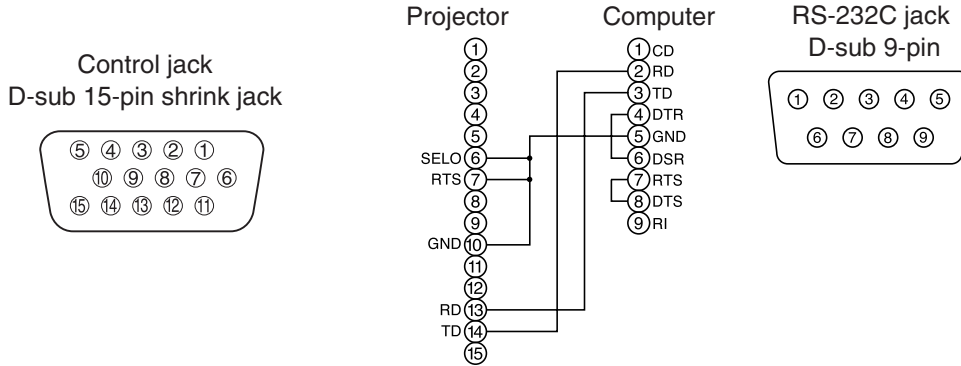

Communications setting

19200bps, 8N1

1 Protocol

Consist of header (7 bytes) + command data (6 bytes).

2 Header

BE + EF + 03 + 06 + 00 + CRC_low + CRC_high

CRC_low : Lower byte of CRC flag for command data.

CRC_high : Upper byte of CRC flag for command data.

3 Command data

Command data chart

| byte_0 | byte_1 | byte_2 | byte_3 | byte_4 | byte_5 |
|--------|--------|--------|--------|--------------|--------|
| Action | | Type | | Setting code | |
| low | high | low | high | low | high |

Action (byte_0 - 1)

| Action | Classification | Content |
|--------|----------------|--------------------------------------|
| 1 | SET | Change setting to desired value. |
| 2 | GET | Read projector internal setup value. |
| 4 | INCREMENT | Increment setup value by 1. |
| 5 | DECREMENT | Decrement setup value by 1. |
| 6 | EXECUTE | Run a command. |

Requesting projector status (Get command)

- (1) Send the request code Header + Command data ('02H'+ '00H'+ type (2 bytes) + '00H'+ '00H') from the computer to the projector.
- (2) The projector returns the response code '1DH'+ data (2 bytes) to the computer.

Changing the projector settings (Set command)

- (1) Send the setting code Header + Command data ('01H'+ '00H'+ type (2 bytes) + setting code (2 bytes)) from the computer to the projector.
- (2) The projector changes the setting based on the above setting code.
- (3) The projector returns the response code '06H' to the computer.

Using the projector default settings (Reset Command)

- (1) The computer sends the default setting code Header + Command data ('06H'+ '00H'+ type (2 bytes) + '00H'+ '00H') to the projector.
- (2) The projector changes the specified setting to the default value.
- (3) The projector returns the response code '06H' to the computer.

Increasing the projector setting value (Increment command)

- (1) The computer sends the increment code Header + Command data ('04H'+ '00H'+ type (2 bytes) + '00H'+ '00H') to the projector.
- (2) The projector increases the setting value on the above setting code.
- (3) The projector returns the response code '06H' to the computer.

Decreasing the projector setting value (Decrement command)

- (1) The computer sends the decrement code Header + Command data ('05H'+ '00H'+ type (2 bytes) + '00H' + '00H') to the projector.
- (2) The projector decreases the setting value on the above setting code.
- (3) The projector returns the response code '06H' to the computer.

When the projector cannot understand the command

When the projector cannot understand a command received from a computer, the projector sends the error code '15H' to the computer.

The projector sometimes cannot receive a command from a computer correctly. In this case, the projector does not execute the command and sends the error code '15H' to the computer. If the computer receives the error code '15H', please resend the same command once again.

When the projector cannot execute the command

When the projector cannot execute a command received from a computer, the projector sends the error code '1cH'+ 'xxxxH' to the computer.

When the data length of a command exceeds the length indicated by the data length code of the command, the projector ignores the exceeded portion of the data. And, when the data length of a command is short of the length indicated by the data length code of the command, the projector sends the error code '1ch'+ 'xxxxH' to the computer.

NOTE • Operation cannot be guaranteed when the projector receives an undefined command or data.

- Provide an interval of at least 40ms between the response code and any other code.
- The projector outputs test data when the power supply is switched ON, and when the lamp is lit. Ignore this data.
- Commands are not accepted during warm-up.

Command data chart

| Names | Operation type | Header | | | | Command data | | |
|------------------|----------------|-------------|----------|----------|----------|--------------|-------|--------------|
| | | | | | CRC | Action | Type | Setting code |
| Blank Color | Set | Blue | BE EF | 03 06 | 00 CB D3 | 01 00 | 00 30 | 03 00 |
| | | White | BE EF | 03 06 | 00 6B D0 | 01 00 | 00 30 | 05 00 |
| | | Black | BE EF | 03 06 | 00 9B D0 | 01 00 | 00 30 | 06 00 |
| | | MyScreen | BE EF | 03 06 | 00 FB CA | 01 00 | 00 30 | 20 00 |
| | | ORIGINAL | BE EF | 03 06 | 00 FB E2 | 01 00 | 00 30 | 40 00 |
| | Get | BE EF | 03 06 | 00 08 D3 | 02 00 | 00 30 | 00 00 | |
| Mirror | Set | Normal | BE EF | 03 06 | 00 C7 D2 | 01 00 | 01 30 | 00 00 |
| | | H Inverse | BE EF | 03 06 | 00 57 D3 | 01 00 | 01 30 | 01 00 |
| | | V Inverse | BE EF | 03 06 | 00 A7 D3 | 01 00 | 01 30 | 02 00 |
| | | H&V Inverse | BE EF | 03 06 | 00 37 D2 | 01 00 | 01 30 | 03 00 |
| | Get | BE EF | 03 06 | 00 F4 D2 | 02 00 | 01 30 | 00 00 | |
| Freeze | Set | Normal | BE EF | 03 06 | 00 83 D2 | 01 00 | 02 30 | 00 00 |
| | | Freeze | BE EF | 03 06 | 00 13 D3 | 01 00 | 02 30 | 01 00 |
| | Get | BE EF | 03 06 | 00 B0 D2 | 02 00 | 02 30 | 00 00 | |
| Startup | Set | ORIGINAL | BE EF | 03 06 | 00 0B D2 | 01 00 | 04 30 | 00 00 |
| | | OFF | BE EF | 03 06 | 00 9B D3 | 01 00 | 04 30 | 01 00 |
| | | MyScreen | BE EF | 03 06 | 00 CB CB | 01 00 | 04 30 | 20 00 |
| | Get | BE EF | 03 06 | 00 38 D2 | 02 00 | 04 30 | 00 00 | |
| Language | Set | English | BE EF | 03 06 | 00 F7 D3 | 01 00 | 05 30 | 00 00 |
| | | Français | BE EF | 03 06 | 00 67 D2 | 01 00 | 05 30 | 01 00 |
| | | Deutsch | BE EF | 03 06 | 00 97 D2 | 01 00 | 05 30 | 02 00 |
| | | Español | BE EF | 03 06 | 00 07 D3 | 01 00 | 05 30 | 03 00 |
| | | Italiano | BE EF | 03 06 | 00 37 D1 | 01 00 | 05 30 | 04 00 |
| | | Norsk | BE EF | 03 06 | 00 A7 D0 | 01 00 | 05 30 | 05 00 |
| | | Nederlands | BE EF | 03 06 | 00 57 D0 | 01 00 | 05 30 | 06 00 |
| | | Português | BE EF | 03 06 | 00 C7 D1 | 01 00 | 05 30 | 07 00 |
| | | 日本語 | BE EF | 03 06 | 00 37 D4 | 01 00 | 05 30 | 08 00 |
| | | 中文 | BE EF | 03 06 | 00 A7 D5 | 01 00 | 05 30 | 09 00 |
| | 한글 | BE EF | 03 06 | 00 57 D5 | 01 00 | 05 30 | 0A 00 | |
| Get | BE EF | 03 06 | 00 C4 D3 | 02 00 | 05 30 | 00 00 | | |
| Magnify | Get | BE EF | 03 06 | 00 7C D2 | 02 00 | 07 30 | 00 00 | |
| | Increment | BE EF | 03 06 | 00 1A D2 | 04 00 | 07 30 | 00 00 | |
| | Decrement | BE EF | 03 06 | 00 CB D3 | 05 00 | 07 30 | 00 00 | |
| Auto off | Get | BE EF | 03 06 | 00 08 86 | 02 00 | 10 31 | 00 00 | |
| | Increment | BE EF | 03 06 | 00 6E 86 | 04 00 | 10 31 | 00 00 | |
| | Decrement | BE EF | 03 06 | 00 BF 87 | 05 00 | 10 31 | 00 00 | |
| Brightness Reset | Execute | BE EF | 03 06 | 00 58 D3 | 06 00 | 00 70 | 00 00 | |
| Contrast Reset | Execute | BE EF | 03 06 | 00 A4 D2 | 06 00 | 01 70 | 00 00 | |
| V.Position Reset | Execute | BE EF | 03 06 | 00 E0 D2 | 06 00 | 02 70 | 00 00 | |

Command data chart

| Names | Operation type | | Header | | | Command data | | |
|-----------------------|----------------|--|----------|----------|-------|--------------|--------|-------|
| | | | | | | CRC | Action | Type |
| H.Position Reset | Execute | | BE EF | 03 06 00 | IC D3 | 06 00 | 03 70 | 00 00 |
| H.Size Reset | Execute | | BE EF | 03 06 00 | 68 D2 | 06 00 | 04 70 | 00 00 |
| Color Balance R Reset | Execute | | BE EF | 03 06 00 | 94 D3 | 06 00 | 05 70 | 00 00 |
| Color Balance B Reset | Execute | | BE EF | 03 06 00 | D0 D3 | 06 00 | 06 70 | 00 00 |
| Sharpness Reset | Execute | | BE EF | 03 06 00 | C4 D0 | 06 00 | 09 70 | 00 00 |
| Color Reset | Execute | | BE EF | 03 06 00 | 80 D0 | 06 00 | 0A 70 | 00 00 |
| Tint Reset | Execute | | BE EF | 03 06 00 | 7C D1 | 06 00 | 0B 70 | 00 00 |
| Keystone_V Reset | Execute | | BE EF | 03 06 00 | 08 D0 | 06 00 | 0C 70 | 00 00 |
| Keystone_H Reset | Execute | | BE EF | 03 06 00 | 98 D8 | 06 00 | 20 70 | 00 00 |
| Auto Adjust | Execute | | BE EF | 03 06 00 | 91 D0 | 06 00 | 0A 20 | 00 00 |
| Lamp Time Reset | Execute | | BE EF | 03 06 00 | 58 DC | 06 00 | 30 70 | 00 00 |
| Filter Time Reset | Execute | | BE EF | 03 06 00 | 98 C6 | 06 00 | 40 70 | 00 00 |
| Blank on/off | Set | off | BE EF | 03 06 00 | FB D8 | 01 00 | 20 30 | 00 00 |
| | | on | BE EF | 03 06 00 | 6B D9 | 01 00 | 20 30 | 01 00 |
| | Get | BE EF | 03 06 00 | C8 D8 | 02 00 | 20 30 | 00 00 | |
| Error Status | Get | BE EF | 03 06 00 | D9 D8 | 02 00 | 20 60 | 00 00 | |
| | | (Example of Return) 00 00 01 00 02 00 03 00 (Normal) (Cover-error) (Fan-error) (Lamp-error) 04 00 05 00 06 00 07 00 08 00 (Temp-error) (Air flow-error) (Lamp-Time-over) (Cool-error) (Filter-Error) | | | | | | |
| Power | Set | OFF | BE EF | 03 06 00 | 2A D3 | 01 00 | 00 60 | 00 00 |
| | | ON | BE EF | 03 06 00 | BA D2 | 01 00 | 00 60 | 01 00 |
| | Get | BE EF | 03 06 00 | 19 D3 | 02 00 | 00 60 | 00 00 | |
| Input Source | Set | RGB1 | BE EF | 03 06 00 | FE D2 | 01 00 | 00 20 | 00 00 |
| | | RGB2 | BE EF | 03 06 00 | 3E D0 | 01 00 | 00 20 | 04 00 |
| | | Video | BE EF | 03 06 00 | 6E D3 | 01 00 | 00 20 | 01 00 |
| | | SVideo | BE EF | 03 06 00 | 9E D3 | 01 00 | 00 20 | 02 00 |
| | | Component | BE EF | 03 06 00 | AE D1 | 01 00 | 00 20 | 05 00 |
| | Get | BE EF | 03 06 00 | CD D2 | 02 00 | 00 20 | 00 00 | |
| Volume | Get | | BE EF | 03 06 00 | 31 D3 | 02 00 | 01 20 | 00 00 |
| | Increment | | BE EF | 03 06 00 | 57 D3 | 04 00 | 01 20 | 00 00 |
| | Decrement | | BE EF | 03 06 00 | 86 D2 | 05 00 | 01 20 | 00 00 |
| Mute | Set | Normal | BE EF | 03 06 00 | 46 D3 | 01 00 | 02 20 | 00 00 |
| | | Mute | BE EF | 03 06 00 | D6 D2 | 01 00 | 02 20 | 01 00 |
| | Get | BE EF | 03 06 00 | 75 D3 | 02 00 | 02 20 | 00 00 | |
| Brightness | Get | | BE EF | 03 06 00 | 89 D2 | 02 00 | 03 20 | 00 00 |
| | Increment | | BE EF | 03 06 00 | EF D2 | 04 00 | 03 20 | 00 00 |
| | Decrement | | BE EF | 03 06 00 | 3E D3 | 05 00 | 03 20 | 00 00 |

Command data chart

| Names | Operation type | | Header | | | Command data | | |
|-------------------------------------|----------------|---------|--------|----------|-------|--------------|--------|-------|
| | | | | | | CRC | Action | Type |
| Contrast | Get | | BE EF | 03 06 00 | FD D3 | 02 00 | 04 20 | 00 00 |
| | Increment | | BE EF | 03 06 00 | 9B D3 | 04 00 | 04 20 | 00 00 |
| | Decrement | | BE EF | 03 06 00 | 4A D2 | 05 00 | 04 20 | 00 00 |
| Color Balance R | Get | | BE EF | 03 06 00 | 01 D2 | 02 00 | 05 20 | 00 00 |
| | Increment | | BE EF | 03 06 00 | 67 D2 | 04 00 | 05 20 | 00 00 |
| | Decrement | | BE EF | 03 06 00 | B6 D3 | 05 00 | 05 20 | 00 00 |
| Color Balance B | Get | | BE EF | 03 06 00 | 45 D2 | 02 00 | 06 20 | 00 00 |
| | Increment | | BE EF | 03 06 00 | 23 D2 | 04 00 | 06 20 | 00 00 |
| | Decrement | | BE EF | 03 06 00 | F2 D3 | 05 00 | 06 20 | 00 00 |
| Keystone_V | Get | | BE EF | 03 06 00 | B9 D3 | 02 00 | 07 20 | 00 00 |
| | Increment | | BE EF | 03 06 00 | DF D3 | 04 00 | 07 20 | 00 00 |
| | Decrement | | BE EF | 03 06 00 | 0E D2 | 05 00 | 07 20 | 00 00 |
| Keystone_H | Get | | BE EF | 03 06 00 | E9 D0 | 02 00 | 0B 20 | 00 00 |
| | Increment | | BE EF | 03 06 00 | 8F D0 | 04 00 | 0B 20 | 00 00 |
| | Decrement | | BE EF | 03 06 00 | 5E D1 | 05 00 | 0B 20 | 00 00 |
| Aspect | Set | 4:3 | BE EF | 03 06 00 | 9E D0 | 01 00 | 08 20 | 00 00 |
| | | 16:9 | BE EF | 03 06 00 | 0E D1 | 01 00 | 08 20 | 01 00 |
| | | Small | BE EF | 03 06 00 | FE D1 | 01 00 | 08 20 | 02 00 |
| | Get | | BE EF | 03 06 00 | AD D0 | 02 00 | 08 20 | 00 00 |
| Picture Position at 16 : 9 or Small | Set | Default | BE EF | 03 06 00 | 62 D1 | 01 00 | 09 20 | 00 00 |
| | | Bottom | BE EF | 03 06 00 | F2 D0 | 01 00 | 09 20 | 01 00 |
| | | Top | BE EF | 03 06 00 | 02 D0 | 01 00 | 09 20 | 02 00 |
| | Get | | BE EF | 03 06 00 | 51 D1 | 02 00 | 09 20 | 00 00 |
| V.Position | Get | | BE EF | 03 06 00 | 0D 83 | 02 00 | 00 21 | 00 00 |
| | Increment | | BE EF | 03 06 00 | 6B 83 | 04 00 | 00 21 | 00 00 |
| | Decrement | | BE EF | 03 06 00 | BA 82 | 05 00 | 00 21 | 00 00 |
| H.Position | Get | | BE EF | 03 06 00 | F1 82 | 02 00 | 01 21 | 00 00 |
| | Increment | | BE EF | 03 06 00 | 97 82 | 04 00 | 01 21 | 00 00 |
| | Decrement | | BE EF | 03 06 00 | 46 83 | 05 00 | 01 21 | 00 00 |
| H.Size | Get | | BE EF | 03 06 00 | B5 82 | 02 00 | 02 21 | 00 00 |
| | Increment | | BE EF | 03 06 00 | D3 82 | 04 00 | 02 21 | 00 00 |
| | Decrement | | BE EF | 03 06 00 | 02 83 | 05 00 | 02 21 | 00 00 |
| H.Phase | Get | | BE EF | 03 06 00 | 49 83 | 02 00 | 03 21 | 00 00 |
| | Increment | | BE EF | 03 06 00 | 2F 83 | 04 00 | 03 21 | 00 00 |
| | Decrement | | BE EF | 03 06 00 | FE 82 | 05 00 | 03 21 | 00 00 |
| Sharpness | Get | | BE EF | 03 06 00 | F1 72 | 02 00 | 01 22 | 00 00 |
| | Increment | | BE EF | 03 06 00 | 97 72 | 04 00 | 01 22 | 00 00 |
| | Decrement | | BE EF | 03 06 00 | 46 73 | 05 00 | 01 22 | 00 00 |
| Color | Get | | BE EF | 03 06 00 | B5 72 | 02 00 | 02 22 | 00 00 |
| | Increment | | BE EF | 03 06 00 | D3 72 | 04 00 | 02 22 | 00 00 |
| | Decrement | | BE EF | 03 06 00 | 02 73 | 05 00 | 02 22 | 00 00 |

Command data chart

| Names | Operation type | Header | | | | Command data | | |
|---------------|----------------|-----------|----------|----------|-------|--------------|-------|--------------|
| | | | | | CRC | Action | Type | Setting code |
| Tint | Get | BE EF | 03 06 00 | 49 73 | 02 00 | 03 22 | 00 00 | |
| | Increment | BE EF | 03 06 00 | 2F 73 | 04 00 | 03 22 | 00 00 | |
| | Decrement | BE EF | 03 06 00 | FE 72 | 05 00 | 03 22 | 00 00 | |
| Video Format | Set | Auto | BE EF | 03 06 00 | 9E 75 | 01 00 | 00 22 | 0A 00 |
| | | NTSC | BE EF | 03 06 00 | FE 71 | 01 00 | 00 22 | 04 00 |
| | | PAL | BE EF | 03 06 00 | 6E 70 | 01 00 | 00 22 | 05 00 |
| | | SECAM | BE EF | 03 06 00 | 6E 75 | 01 00 | 00 22 | 09 00 |
| | | NTSC 4.43 | BE EF | 03 06 00 | 5E 72 | 01 00 | 00 22 | 02 00 |
| | | M-PAL | BE EF | 03 06 00 | FE 74 | 01 00 | 00 22 | 08 00 |
| | N-PAL | BE EF | 03 06 00 | 0E 71 | 01 00 | 00 22 | 07 00 | |
| Get | BE EF | 03 06 00 | 0D 73 | 02 00 | 00 22 | 00 00 | | |
| HDTV | Set | 1080i | BE EF | 03 06 00 | F2 73 | 01 00 | 05 22 | 00 00 |
| | | 1035i | BE EF | 03 06 00 | 62 72 | 01 00 | 05 22 | 01 00 |
| | Get | BE EF | 03 06 00 | C1 73 | 02 00 | 05 22 | 00 00 | |
| Sync on G | Set | off | BE EF | 03 06 00 | CB D0 | 01 00 | 08 30 | 01 00 |
| | | on | BE EF | 03 06 00 | 5B D1 | 01 00 | 08 30 | 00 00 |
| | Get | BE EF | 03 06 00 | 68 D1 | 02 00 | 08 30 | 00 00 | |
| WHISPER | Set | NORMAL | BE EF | 03 06 00 | 3B 23 | 01 00 | 00 33 | 00 00 |
| | | WHISPER | BE EF | 03 06 00 | AB 22 | 01 00 | 00 33 | 01 00 |
| | Get | BE EF | 03 06 00 | 08 23 | 02 00 | 00 33 | 00 00 | |
| GAMMA | Set | NORMAL | BE EF | 03 06 00 | C7 F0 | 01 00 | A1 30 | 00 00 |
| | | CINEMA | BE EF | 03 06 00 | 57 F1 | 01 00 | A1 30 | 01 00 |
| | | DYNAMIC | BE EF | 03 06 00 | A7 F1 | 01 00 | A1 30 | 02 00 |
| | Get | BE EF | 03 06 00 | F4 F0 | 02 00 | A1 30 | 00 00 | |
| Over Scan | Set | Large | BE EF | 03 06 00 | C2 71 | 01 00 | 09 22 | 02 00 |
| | | Middle | BE EF | 03 06 00 | 32 71 | 01 00 | 09 22 | 01 00 |
| | | Small | BE EF | 03 06 00 | A2 70 | 01 00 | 09 22 | 00 00 |
| | Get | BE EF | 03 06 00 | 91 70 | 02 00 | 09 22 | 00 00 | |
| MyScreen Size | Set | Full | BE EF | 03 06 00 | 43 D6 | 01 00 | 12 30 | 00 00 |
| | | X1 | BE EF | 03 06 00 | D3 D7 | 01 00 | 12 30 | 01 00 |
| | Get | BE EF | 03 06 00 | 70 D6 | 02 00 | 12 30 | 00 00 | |
| MyScreen Lock | Set | off | BE EF | 03 06 00 | 3B EF | 01 00 | C0 30 | 00 00 |
| | | on | BE EF | 03 06 00 | AB EE | 01 00 | C0 30 | 01 00 |
| | Get | BE EF | 03 06 00 | 08 EF | 02 00 | C0 30 | 00 00 | |
| Lamp Time | Get | BE EF | 03 06 00 | C2 FF | 02 00 | 90 10 | 00 00 | |
| Filter Time | Get | BE EF | 03 06 00 | C2 F0 | 02 00 | A0 10 | 00 00 | |

HITACHI

Hitachi, Ltd. Tokyo, Japan
International Sales Division
THE HITACHI ATAGO BUILDING,
No. 15-12 Nishi Shinbashi, 2 - Chome,
Minato - Ku, Tokyo 105-8430, Japan.
Tel: 03 35022111

HITACHI EUROPE LTD,

Whitebrook Park
Lower Cookham Road
Maidenhead
Berkshire
SL6 8YA

UNITED KINGDOM

Tel: 01628 643000
Fax: 01628 643400
Email: consumer-service@hitachi-eu.com

HITACHI EUROPE S.A.

364 Kifissias Ave. & 1, Delfon Str.
152 33 Chalandri
Athens

GREECE

Tel: 1-6837200
Fax: 1-6835964
Email: service.hellas@hitachi-eu.com

HITACHI EUROPE GmbH

Munich Office
Dornacher Strasse 3
D-85622 Feldkirchen bei München

GERMANY

Tel: +49-89-991 80-0
Fax: +49-89-991 80-224
Hotline: +49-180-551 25 51 (12ct/min)
Email: HSE-DUS.service@hitachi-eu.com

HITACHI EUROPE S.A.

Gran Via Carlos III, 86, planta 5
Edificios Trade - Torre Este
08028 Barcelona

SPAIN

Tel: 93 409 2550
Fax: 93 491 3513
Email: atencion.cliente@hitachi-eu.com

HITACHI EUROPE srl

Via Tommaso Gulli N.39, 20147
Milano, Italia

ITALY

Tel: +39 02 487861
Tel: +39 02 38073415 Servizio Clienti
Fax: +39 02 48786381/2
Email: customerservice.italy@hitachi-eu.com

HITACHI Europe AB

Box 77 S-164 94 Kista

SWEDEN

Tel: +46 (0) 8 562 711 00
Fax: +46 (0) 8 562 711 13
Email: csgswe@hitachi-eu.com

HITACHI EUROPE S.A.S

Lyon Office
B.P. 45, 69671 BRON CEDEX

FRANCE

Tel: 04 72 14 29 70
Fax: 04 72 14 29 99
Email: france.consommateur@hitachi-eu.com

HITACHI EUROPE LTD (Norway) AB

STRANDVEIEN 18

1366 Lysaker

NORWAY

Tel: 67 5190 30
Fax: 67 5190 32
Email: csgnor@hitachi-eu.com

HITACH EUROPE AB

Egebækgård
Egebækvej 98
DK-2850 Nærum

DENMARK

Tel: +45 43 43 6050
Fax: +45 43 60 51
Email: csgnor@hitachi-eu.com

HITACHI EUROPE AB

Neopoli / Niemenkatu 73
FIN-15140 Lahti

FINLAND

Tel : +358 3 8858 271
Fax: +358 3 8858 272
Email: csgnor@hitachi-eu.com

Hitachi Europe Ltd

Bergensesteenweg 421
1600 Sint-Pieters-Leeuw

BELGIUM

Tel: +32 2 363 99 01
Fax: +32 2 363 99 00
Email: sofie.van.bom@hitachi-eu.com

HITACHI EUROPE LTD

Na Sychrove 975/8
101 27 Praha 10 - Bohdalec

CZECH REPUBLIC

Tel: +420 267 212 383
Fax: +420 267 212 385
Email: csgnor@hitachi-eu.com

Free Manuals Download Website

<http://myh66.com>

<http://usermanuals.us>

<http://www.somanuals.com>

<http://www.4manuals.cc>

<http://www.manual-lib.com>

<http://www.404manual.com>

<http://www.luxmanual.com>

<http://aubethermostatmanual.com>

Golf course search by state

<http://golfingnear.com>

Email search by domain

<http://emailbydomain.com>

Auto manuals search

<http://auto.somanuals.com>

TV manuals search

<http://tv.somanuals.com>