

OPERATING AND SERVICE MANUAL

hp-400F/FL

AC VOLTMETER

400F/FL

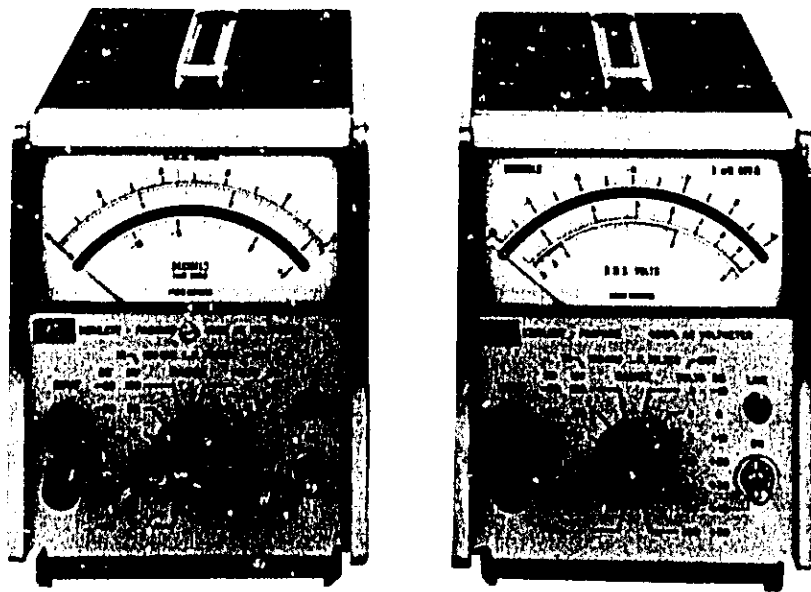

HEWLETT  PACKARD

hp-400F/F



OPERATING AND SERVICE MANUAL

-hp- Part Number 00400-90016

MODEL 400F/FL AC VOLTMETER

Serials Prefixed: 0950A

Appendix C, Manual Backdating Changes, adapts this manual to serials prefixed 617-, 734-, 912-.

**Copyright Hewlett-Packard Company 1966
P.O. Box 301, Loveland, Colorado, 80537 U.S.A.**

Printed: July 1974

HEWLETT  PACKARD

CERTIFICATION

The Hewlett-Packard Company certifies that this instrument was thoroughly tested and inspected and found to meet its published specifications when it was shipped from the factory. The Hewlett-Packard Company further certifies that its calibration measurements are traceable to the U.S. National Bureau of Standards to the extent allowed by the Bureau's calibration facility.

WARRANTY AND ASSISTANCE

All Hewlett-Packard products are warranted against defects in materials and workmanship. This warranty applies for one year from the date of delivery, or, in the case of certain major components listed in the operating manual, for the specified period. We will repair or replace products which prove to be defective during the warranty period provided they are returned to Hewlett-Packard. No other warranty is expressed or implied. We are not liable for consequential damages.

Service contracts or customer assistance agreements are available for Hewlett-Packard products that require maintenance and repair on-site.

For any assistance, contact your nearest Hewlett-Packard Sales and Service Office. Addresses are provided at the back of this manual.

TABLE OF CONTENTS

Section	Page	Section	Page
I. GENERAL INFORMATION	1-1	V. MAINTENANCE	5-1
1-1. Description	1-1	5-1. Introduction	5-1
1-4. Option (400F Only)	1-1	5-3. Test Equipment Required	5-1
1-6. Instrument and Manual Identification	1-1	5-5. Performance Tests	5-1
1-8. Backdating Information	1-1	5-11. Top Cover Removal	5-2
		5-13. Accuracy and Frequency Response Tests	5-2
Section	Page	5-15. Range Tracking Test	5-3
II. INSTALLATION	2-1	5-17. Noise and Filter Test	5-3
2-1. Introduction	2-1	5-18. Input Impedance Test	5-3
2-3. Initial Inspection	2-1	5-21. Alignment and Calibration Procedures	5-4
2-5. Power Requirements	2-1	5-23. Cover Removal Replacement	5-4
2-7. Grounding Requirements	2-1	5-27. Meter Mechanical Zero Adjustment	5-5
2-10. Installation	2-1	5-29. A2Q1 Bias Adjustment	5-5
2-12. Bench Mounting	2-1	5-31. Meter Calibration	5-5
2-14. Rack Mounting	2-1	5-35. Attenuator Alignment	5-6
2-16. Combination Mounting	2-1	5-37. Replacement of A2C37*	5-6
2-18. Repackaging for Shipment	2-1	5-40. Troubleshooting Procedure	5-6
		5-45. Power Supply	5-6
Section	Page	5-48. Preamplifier	5-6
III. OPERATING INSTRUCTIONS	3-1	5-51. Meter Amplifier	5-7
3-1. Introduction	3-1	5-54. Meter Bridge	5-7
3-3. Controls, Indicators and Connectors	3-1	5-56. Etched Circuit Board Repair	5-7
3-5. Meter Mechanical Zero Adjustment (400F Only)	3-1		
3-7. Turn-On Procedures	3-1	Section	Page
3-8. AC Voltage Measurements	3-1	VI. REPLACEABLE PARTS	6-1
3-9. DB Measurements	3-2	6-1. Introduction	6-1
3-10. Wide Band AC Amplifier	3-2	6-4. Ordering Information	6-1
3-11. 400F With Option 01	3-2	6-6. Non-Listed Parts	6-1
Section	Page	Section	Page
IV. THEORY OF OPERATION	4-1	VII. TROUBLESHOOTING AND CIRCUIT DIAGRAMS	7-1
4-1. General	4-1	7-1. Introduction	7-1
4-3. Block Diagram Description	4-1		
4-5. Schematic Theory	4-1	APPENDICES	
4-7. Input Attenuator	4-1	A. CODE LIST OF MANUFACTURERS	
4-9. Preamplifier	4-1	B. SALES AND SERVICE OFFICES	
4-13. Post Attenuator	4-1	C. MANUAL BACKDATING	
4-15. 100 kHz Low Pass Filter	4-1		
4-17. Meter Amplifier	4-1		
4-22. Meter Bridge	4-2		
4-27. Power Supply	4-3		

LIST OF ILLUSTRATIONS

Figure	Page
3-1. Location of Controls and Indicators	3-0
3-2. External Battery Connection	3-1
3-3. Impedance Correction Graph	3-3
4-1. Functional Circuit Diagram	4-0
4-2. Filter Attenuation Characteristics	4-1
4-3. Simplified Diagram of Metering Circuit	4-2
5-1. Accuracy and Frequency Response Test Setup	5-2
5-2. 1 k Ω Shielded Resistor	5-4
5-3. Input Impedance Test Setup	5-4
5-4. Location of Internal Adjustments	5-5
6-1. Location of Important Mechanical Parts	6-2
7-1. Model 400F/FL Range Switch and p/o Internal Wiring Data	7-2
7-2. Model 400F/FL Schematic Diagram	7-3/7-4

LIST OF TABLES

Table	Page
1-1. Specifications	1-1
1-2. Performance Characteristics	1-2
3-1. Effect of Distortion on Average Responding Meter	3-1
3-2. AC Amplifier Gain Factors	3-2
5-1. Test Equipment	5-1
5-2. Full Scale Calibration Tolerances	5-2
5-3. Noise Level Specifications	5-3
5-4. Front Panel Troubleshooting Guide	5-7
6-1. Replaceable Parts	6-2

SECTION I GENERAL INFORMATION

1-1. DESCRIPTION.

1-2. The -hp- Models 400F and 400FL are versatile ac voltmeters and dB meters. Both models can be used as wideband amplifiers. The Model 400F is primarily intended for voltage measurements, whereas the Model 400FL is primarily a dB meter. However, both meters indicate both volts and dB. The 400F has a linear ac scale with a logarithmic dB scale underneath, and the 400FL has a linear dB scale with a logarithmic ac scale underneath. Since the difference in scales is the only difference between the two instruments, this manual will use the term 400F/FL in reference to both instruments.

1-3. The front cover shows both the Model 400F and the Model 400FL. Table 1-1 is a list of specifications.

1-4. OPTION (400F ONLY).

1-5. Option 01 is a standard -hp- Model 400F AC Voltmeter which has a dB scale that reads from -15 to +2

instead of from -12 to +2. The dB scale is placed at the top of the meter face for better resolution.

1-6. INSTRUMENT AND MANUAL IDENTIFICATION.

1-7. Hewlett-Packard uses a two-section serial number. If the first section (serial prefix) of the serial number on your instrument does not agree with those on the title page of this manual, change sheets supplied with the manual will define the differences between your instrument and the Model 400F/FL described in this manual. Some serial numbers may have a letter separating the two sections of the number. This letter indicates the country in which the instrument was manufactured (A = U.S.A.; G = West Germany; J = Japan; U = United Kingdom).

1-8. BACKDATING INFORMATION.

1-9. Appendix C contains backdating information that adapts this manual to instruments with serials prefixed 617, 734, and 912.

Table 1-1. Specifications.

<p>Voltage Range: 100 μV to 300 V full scale, 14 ranges in 1, 3, 10 sequence.</p> <p>Frequency Range: 20 Hz to 4 MHz.</p> <p>Calibration: Responds to absolute average value of applied signal, calibrated in rms volts.</p> <p>*Accuracy specifications apply above one-tenth of full scale. Noise may cause zero offset on sensitive ranges (see the noise specifications below).</p> <p>Noise Referred to Input: (1000 Ω termination)</p> <table style="margin-left: 40px; border-collapse: collapse;"> <thead> <tr> <th style="text-align: left; border-bottom: 1px solid black;">Range</th> <th style="text-align: left; border-bottom: 1px solid black;">Filter In</th> <th style="text-align: left; border-bottom: 1px solid black;">Filter Out</th> </tr> </thead> <tbody> <tr> <td>300 μV to 300 V</td> <td>< 5 μV</td> <td>< 30 μV</td> </tr> <tr> <td>100 μV</td> <td>< 5 μV</td> <td>< 15 μV</td> </tr> </tbody> </table> <p>Note: Noise adds to the signal approximately according to the relation:</p> $\text{Reading} = \sqrt{(\text{signal})^2 + (\text{noise})^2}$ <p>Input Impedance: 10 MΩ shunted by < 30 pF on the 100 μV - 300 mV ranges and 10 MΩ shunted by < 15 pF on the 1 V - 300 V ranges.</p>	Range	Filter In	Filter Out	300 μ V to 300 V	< 5 μ V	< 30 μ V	100 μ V	< 5 μ V	< 15 μ V	<p>Amplifier AC Output: 1 V rms, open circuit, for full scale indication; output impedance 600 Ω, Frequency Response 20 Hz to 4 MHz on 1 mV to 300 V ranges. 30 Hz to 100 kHz on 100 μV and 300 μV range, 100 kHz filter in the "in" position on the 100 μV and 300 μV range.</p> <p>Meter Response: < 1 second after application of signal.</p> <p>Recovery From Overload: < 2 seconds for 80 dB overload.</p> <p>AC Power: 115 or 230 V \pm 10%, 48 to 440 Hz, 5 watts.</p> <p>External Battery Operation: Terminals are provided on rear panel; positive and negative voltages between 35 V and 55 V are required. Current drain from each voltage is approximately 45 mA.</p> <p>Temperature Range: 0 to +55$^{\circ}$C.</p> <p>Weight:</p> <p>Net: 6 lbs. (2, 7 kg).</p> <p>Shipping: 9 lbs. (4 kg).</p> <p>Dimensions: 6 1/2" high, 5 1/8" wide, 11" deep (165, 1 x 130, 2 x 279, 4 mm).</p>
Range	Filter In	Filter Out								
300 μ V to 300 V	< 5 μ V	< 30 μ V								
100 μ V	< 5 μ V	< 15 μ V								

Model 400F/FL							
Accuracy: \pm (% Full Scale + % Reading) *(see above)							
300 μ V to 300 V ranges	Frequency	20 Hz	40 Hz	100 Hz	1 MHz	2 MHz	4 MHz
		\pm (2 + 2)	\pm (1 + 1)	\pm (1/2 + 1/2)	\pm (1 + 1)	\pm (2 + 2)	
100 μ V range	Frequency	30 Hz	60 Hz	100 kHz	500 kHz		
		\pm (2 + 2)	\pm (1 + 1)	\pm 1 +0 -7			

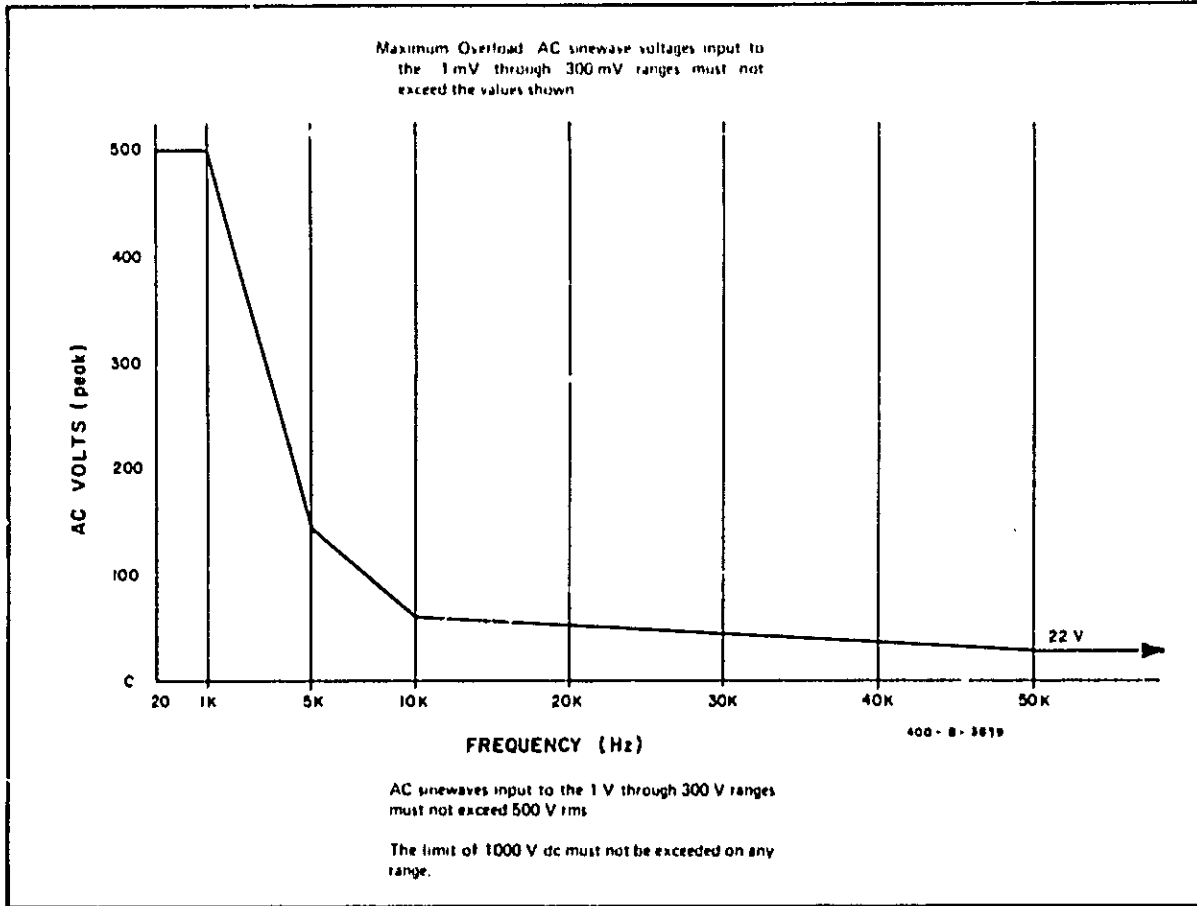

Table 1-2. Performance Characteristics.

SECTION II INSTALLATION

2-1. INTRODUCTION.

2-2. This section contains information and instructions necessary for the installation and shipping of the Model 400F and 400FL voltmeters. Included are initial inspection procedures, power and grounding requirements, installation information and instructions for repackaging for shipment.

2-3. INITIAL INSPECTION.

2-4. This instrument was carefully inspected, both mechanically and electrically, before shipment. It should be physically free of marks or scratches and in perfect electrical order upon receipt. To confirm this, the instrument should be inspected for physical damage in transit. Also check for supplied accessories and test the electrical performance of the instrument using the procedure outlined in Paragraph 5-5. If there is damage or deficiency, see the warranty on the inside front cover of this manual.

2-5. POWER REQUIREMENTS.

2-6. The Model 400F/FL can be operated from any source of 115 or 230 volts at 48 to 440 Hz or from two 35 to 55 volt batteries connected to the rear panel BATTERY terminals. The 115/230 V slide switch on the rear panel selects the desired line voltage. Power dissipation is 5 watts maximum.

2-7. GROUNDING REQUIREMENTS.

2-8. To protect operating personnel, the National Electrical Manufacturers' Association (NEMA) recommends that the instrument panel and cabinet be grounded. All Hewlett-Packard instruments are equipped with a three-conductor power cable which, when plugged into an appropriate receptacle, grounds the instrument. The offset pin on the power cable three-prong connector is the ground wire.

2-9. To preserve the protection feature when operating the instrument from a two-contact outlet, use a three-prong to two-prong adapter and connect the green pigtail on the adapter to ground.

2-10. INSTALLATION.

2-11. The Model 400F/FL is fully transistorized, therefore, no special cooling is required. However, the instrument should not be operated where the ambient temperature exceeds 55°C (131°F) or the relative humidity exceeds 95%.

2-12. Bench Mounting.

2-13. The Model 400F/FL is shipped with plastic feet and tilt stand in place, ready for use as a bench instrument.

2-14. Rack Mounting.

2-15. The Model 400F/FL may be rack mounted by using an adapter frame (-hp- Part No. 5060-0797). The adapter frame is a rack frame that accepts any combination of submodular units. It can be rack mounted only. For additional information, address inquiries to your -hp- Sales and Service Office. (See Appendix B for office locations.)

2-16. Combination Mounting.

2-17. The Model 400F/FL may be mounted in combination with other submodular units by using a Combining Case (-hp- Model 1051A or 1052A). The Combining Case is a full-module unit which accepts various combinations of submodular units. Being a full-module unit, it can be bench or rack mounted and is analogous to any full-module instrument.

2-18. REPACKAGING FOR SHIPMENT.

2-19. The following paragraphs contain a general guide for repackaging of the instrument for shipment. Refer to Paragraph 2-20 if the original container is to be used, 2-21 if it is not. If you have any questions, contact your local -hp- Sales and Service Office. (See Appendix B for office locations.)

NOTE

If the instrument is to be shipped to Hewlett-Packard for service or repair, attach a tag to the instrument identifying the owner and indicating the service or repair to be accomplished. Include the model number and full serial number of the instrument. In any correspondence, identify the instrument by model number, serial number, and serial number prefix.

2-20. If original container is to be used, proceed as follows:

a. Place instrument in original container if available. If original container is not available, one can be purchased from your nearest -hp- Sales and Service Office.

b. Ensure that container is well sealed with strong tape or metal bands.

2-21. If original container is not to be used, proceed as follows:

a. Wrap instrument in heavy paper or plastic before placing in an inner container.

b. Place packing material around all sides of instrument and protect panel face with cardboard strips.

c. Place instrument and inner container in a heavy carton or wooden box and seal with strong tape or metal bands.

d. Mark shipping container with "DELICATE INSTRUMENT," "FRAGILE," etc.

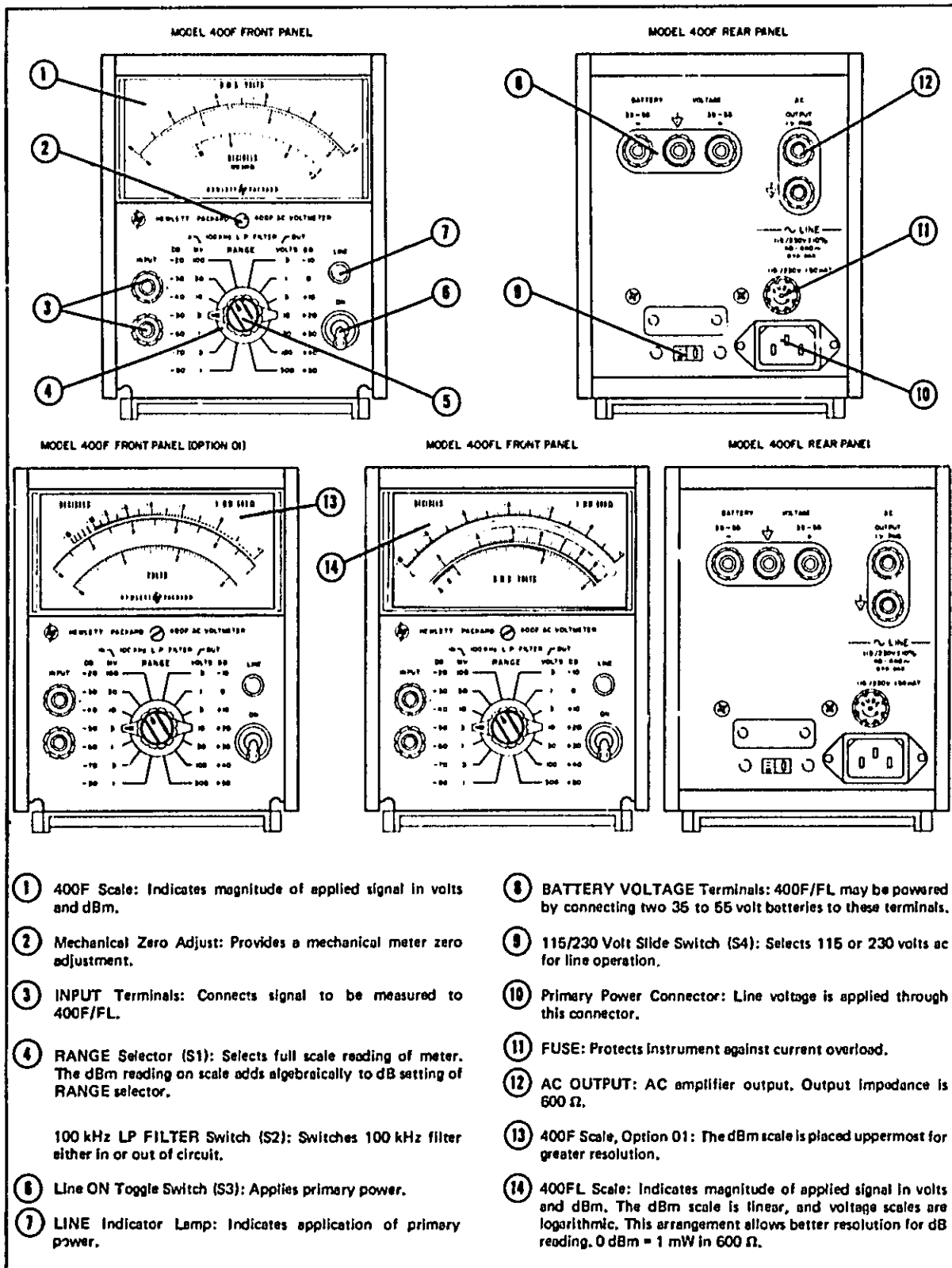

Figure 3-1. Location of Controls and Indicators.

SECTION III OPERATING INSTRUCTIONS

3-1. INTRODUCTION.

3-2. This section contains instructions and information necessary for the operation of the 400F/FL AC Voltmeters. Included is identification of controls, indicators and connectors, turn-on procedures and operating instructions.

3-3. CONTROLS, INDICATORS AND CONNECTORS.

3-4. Each control, indicator and connector on the 400F/FL is identified and described in Figure 3-1.

3-5. METER MECHANICAL ZERO ADJUSTMENT (400F ONLY).

3-6. The mechanical zero adjustment is located in the center of the instrument front panel. If the meter pointer does not indicate zero after the instrument has been off at least one minute, mechanically zero the meter, following the steps outlined below.

- a. Turn instrument power off and allow at least one hour for meter pointer to stabilize. An alternate method is to turn instrument power off and short the meter terminals.
- b. Rotate zero adjustment screw clockwise until pointer is left of zero and moving upscale.
- c. Continue rotating screw clockwise until pointer is at zero. Stop when pointer is exactly on zero. If pointer overshoots, repeat step b.
- d. When pointer is exactly over zero, rotate adjustment screw slightly counterclockwise to relieve tension on pointer suspension. If pointer moves to the left, repeat the entire procedure but make counterclockwise rotation less.

3-7. TURN-ON PROCEDURES.

a. If line voltage is used, ensure that the 115-230 V ac switch (located on the rear panel) is in the correct position. Turn the line ON toggle switch to the ON position. The LINE lamp will glow indicating that line power is applied.

b. If batteries are used, connect two 35 to 55 volt batteries as shown in Figure 3-2. The line ON switch is not in the circuit when batteries are used, therefore, an external DPST switch should be used to provide a means for disconnecting the batteries when the instrument is not in use.

WARNING

When used in battery operation, there is no ground return through the power cord. Connect the black terminal on the rear panel to earth ground.

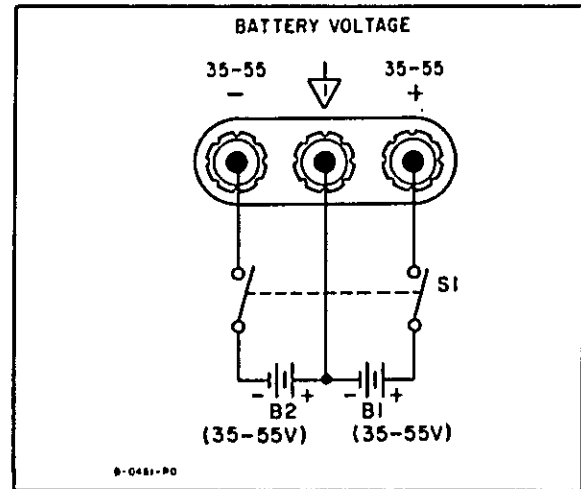

Figure 3-2. External Battery Connection.

3-8. AC VOLTAGE MEASUREMENTS.

NOTE

Since the 400F/FL is average responding and rms calibrated, any distortion will affect the accuracy of the measurement. Table 3-1 shows the errors caused by distortions.

- a. Perform the steps listed under Paragraphs 3-5 and 3-7.
- b. Set the meter RANGE switch to the approximate range of the voltage to be measured.

Table 3-1. Effect of Distortion on Average Responding Meter.

Harmonic	% Distortion	% Error (* Fundamental)	
		Max. Positive	Max. Negative
Any Even	0.1	0.000	
	0.5	0.001	
	1.0	0.005	
	2.0	0.020	
Third	0.1	0.033	0.033
	0.5	0.168	0.167
	1.0	0.338	0.328
	2.0	0.687	0.667
Fifth	0.1	0.020	0.020
	0.5	0.101	0.099
	1.0	0.205	0.195
	2.0	0.420	0.380

* Depends on phase relationship between harmonic and fundamental.

CAUTION

Do not apply more than 500 volts to INPUT. Do not overload the .1 mV through .3 volt ranges. Consult Table 1-2 for overload limits. If any of these overloads are exceeded, the instrument may be damaged.

c. If the signal to be measured is a frequency less than 100 kHz, the 100 kHz L.P. FILTER may be switched in to filter out all frequency components above 100 kHz.

d. Connect the signal to be measured to the INPUT terminals. The RMS voltage amplitude of the input will be indicated on the meter.

3-9. DB MEASUREMENTS.

a. Perform the steps listed under Paragraphs 3-5 and 3-7.

b. The dB measurement is equal to the algebraic sum of the meter indication and the RANGE setting. For example, if the RANGE setting is + 20 dB and the meter reading is - 3 dB, the actual dB measurement is + 17 dB.

c. The dB scale of the 400F/FL is calibrated in dBm. 0 dBm is equivalent to 1 milliwatt dissipated by a 600 ohm load. Therefore, all measurements in dBm must be made across a total impedance of 600 ohms. Measurements across all other impedances will be in dB but not in dBm.

d. A reading in dB may be converted to dBm by using the Impedance Correction Graph (Figure 3-3). For example, to convert a 40 dB reading across 100 ohms to dBm, locate the 100 ohm load impedance on the bottom of the graph. Follow the impedance line to the heavy black line and read the meter correction at that point. The correction for 100 ohms is + 7.5 dBm; the corrected reading is 40 dB + 7.5 dBm = + 47.5 dBm.

3-10. WIDE BAND AC AMPLIFIER.**CAUTION**

Extreme care should be taken to avoid common ground paths between the INPUT and OUTPUT signals. Because of the high gain of the instrument on the more sensitive ranges (80 dB on .1 mV RANGE, etc.), common ground paths can cause oscillations at higher frequencies.

a. Perform the steps listed in Paragraphs 3-5 and 3-7.

b. Set the meter RANGE switch to the approximate range of the input signal.

c. When signals of frequencies less than 100 kHz are being amplified, the 100 kHz L.F. FILTER may be switched in to reduce high frequency noise and lessen the possibility of oscillations.

d. Connect the input signal to the INPUT terminals.

e. Table 3-2 shows the gain factor for each range of the 400F/FL into an open circuit.

Table 3-2. AC Amplifier Gain Factors.

Range	Gain	Range	Gain
300 V	- 50 dB	100 mV	+ 20 dB
100 V	- 40 dB	30 mV	+ 30 dB
30 V	- 30 dB	10 mV	+ 40 dB
10 V	- 20 dB	3 mV	+ 50 dB
3 V	- 10 dB	1 mV	+ 60 dB
1 V	0 dB	.3 mV	+ 70 dB
.3 V	+ 10 dB	.1 mV	+ 80 dB

3-11. 400F WITH OPTION 01.

3-12. Operating procedures for the 400F with Option 01 are the same as the operating procedures for the standard 400F. The only difference between the two models is the scale layout. The 400F with Option 01 has a dB scale which reads from - 15 to + 2 instead of from - 12 to + 2. The dB scale is placed at the top of the meter face for better resolution.

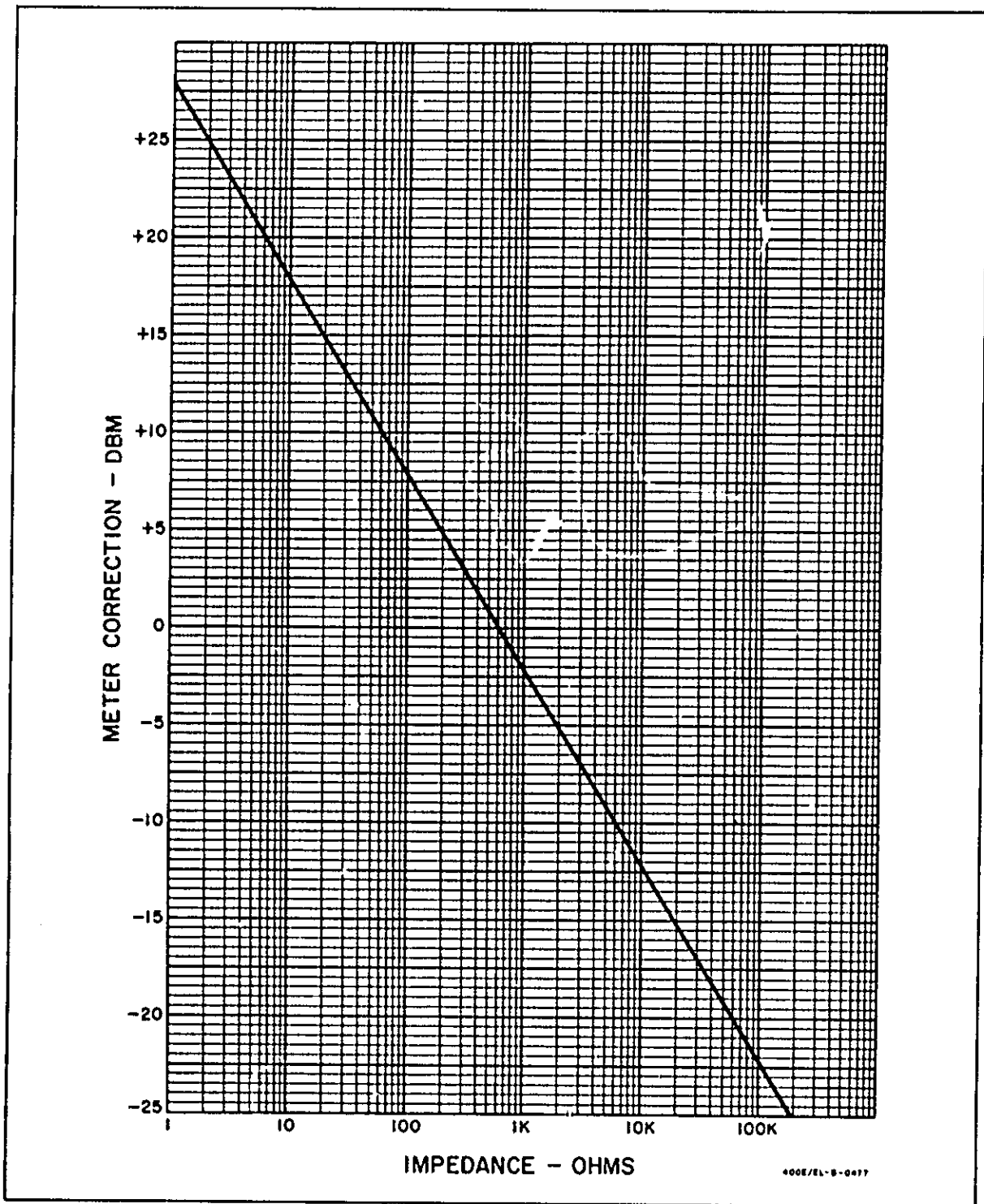

Figure 3-3. Impedance Correction Graph.

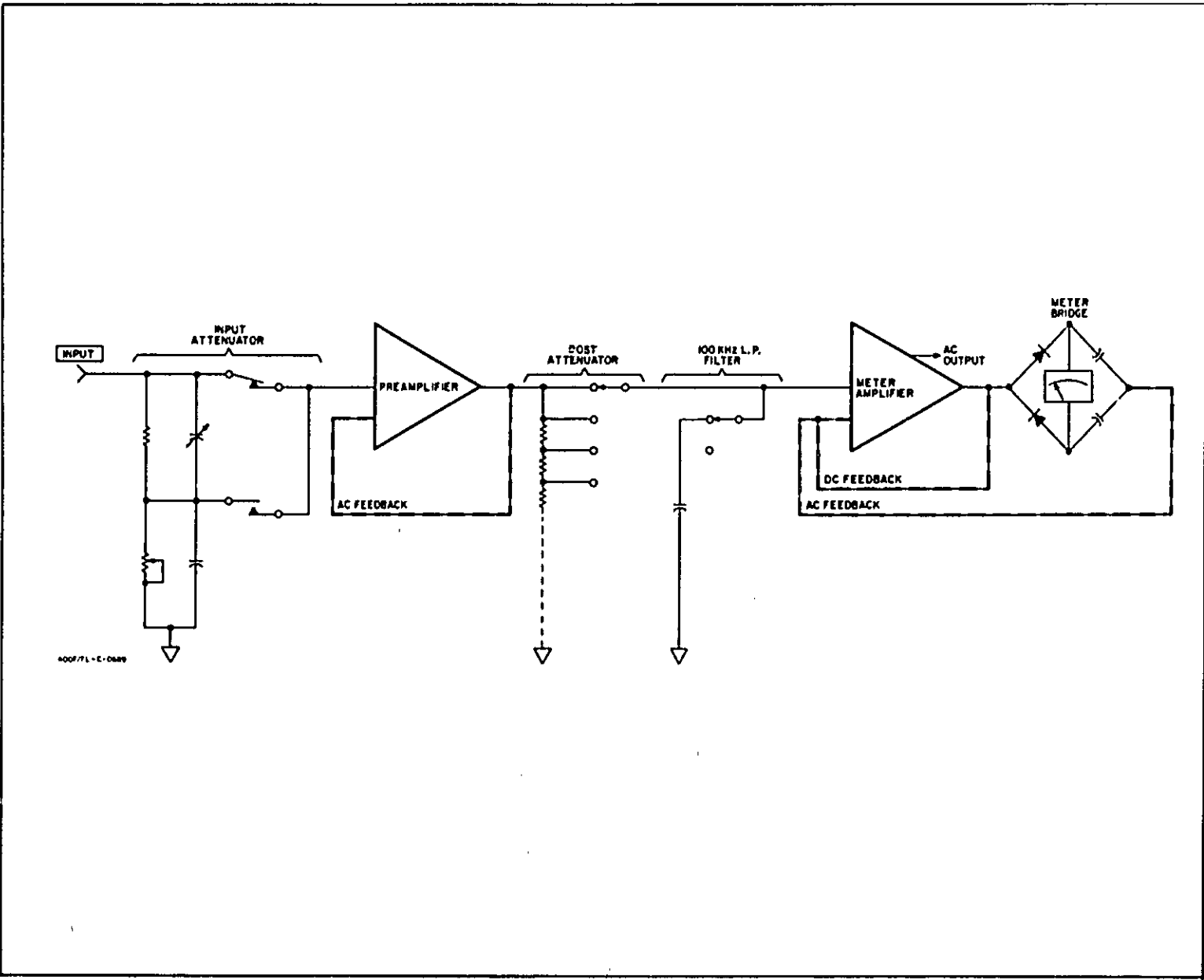

Figure 4-1. Functional Circuit Diagram.

SECTION IV

THEORY OF OPERATION

4-1. GENERAL.

4-2. The 400F/FL is a solid state, average responding, rms calibrated ac voltmeter. It may also be used as a wide band ac amplifier, with switchable gain and switchable bandwidth. Refer to Figure 4-1 for a functional circuit diagram of the instrument.

4-3. BLOCK DIAGRAM DESCRIPTION.

4-4. The voltage to be measured is applied to the input attenuator, where it is either attenuated by 60 dB, or coupled directly to the preamplifier. The preamplifier provides 10 dB of gain for the input signal and applies it to the post attenuator. The signal goes from the post attenuator to the 100 kHz LOW PASS filter, which may be switched in to limit the bandwidth to signals from 20 Hz to 100 kHz. The meter amplifier then amplifies the signal, couples it to the meter bridge and supplies a signal to the AC OUTPUT terminal. The meter bridge rectifies the ac signal and applies it to meter M1, which indicates the rms value of the input voltage. The meter bridge also provides the ac feedback to the meter amplifier.

4-5. SCHEMATIC THEORY.

4-6. Refer to Figure 7-2 for the following discussion.

4-7. Input Attenuator.

4-8. The input attenuator consists of an rc voltage divider and two reed relays. On the .1 mV through .3 V ranges, reed relay A1K1 is energized by - 26 V from wafer (A) of the RANGE switch, S1, routing the input signal directly to the preamplifier. On all other ranges, the - 26 V is applied to relay A1K2. When A1K2 is closed, the input signal is attenuated 60 dB by the rc divider and coupled to the preamplifier.

4-9. Preamplifier.

4-10. The preamplifier is a three stage ac amplifier that amplifies the signal from the input attenuator by 10 dB. It also functions as an impedance matcher to match the high impedance of the input attenuator to the much lower impedance of the post attenuator.

4-11. Capacitor A2C5 blocks dc transients and couples the ac signal to the preamplifier. The input signal is limited to 5.4 volts peak-to-peak by diodes A2CR2 and A2CR4, which are biased at - 2.7 V and + 2.7 V respectively, by zener diodes A2CR1 and A2CR5. A field effect transistor, A2Q1, is used as the input stage of the preamplifier because of its low noise characteristics and high input impedance.

The signal is taken from the drain of A2Q1 and is further amplified by A2Q2 and A2Q3.

4-12. Feedback from the emitter of A2Q2 bootstraps the value of A2R9, the drain load of A2Q1. Feedback from the source of A2Q1 bootstraps the input impedance of the preamplifier and keeps it at a high level over all ranges of inputs. Gain stability and linearity of the preamplifier are maintained by feedback from the collector of A2Q2 and the emitter of A2Q3. A2R6 provides a bias adjustment for the field effect transistor, A2Q1.

4-13. Post Attenuator.

4-14. The post attenuator is a precision resistive voltage divider that operates as a function of the RANGE switch. On the two lowest voltage ranges, the signal from the preamplifier is applied through two resistors (S1R1 and S1R15) to the 100 kHz LP FILTER and receives no attenuation. Six precision resistive divider circuits provide signal attenuation in progressive steps of 10 dB for the twelve higher ranges.

4-15. 100 kHz Low Pass Filter.

4-16. The 100 kHz LP FILTER is a 0.01 μ F capacitor (S1C1) which may be switched into or out of the circuit by switch S2. When the filter is in the circuit, the bandwidth of the instrument is from 20 Hz to 100 kHz. If the filter is switched out of the circuit, the bandwidth is increased to 4 MHz. Refer to Figure 4-2 for a graph of the filter attenuation characteristics.

4-17. Meter Amplifier.

4-18. The meter amplifier is a four stage, direct coupled voltage and power amplifier. The first stage is a differential

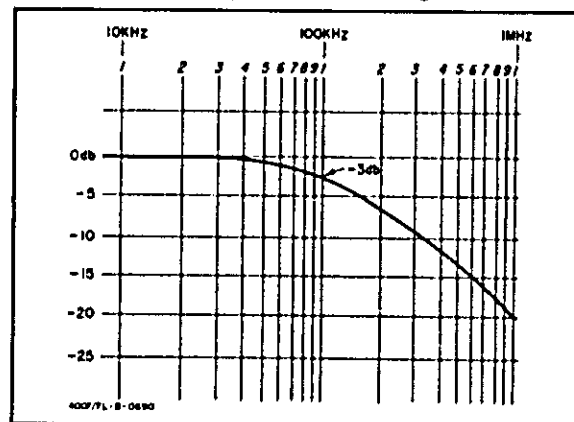

Figure 4-2. Filter Attenuation Characteristics.

amplifier, A2Q10 and A2Q12, which amplifies the difference between the input signal and the feedback signal on the base of A2Q12, the feedback summing junction. The three other stages of amplification are provided by A2Q11, A2Q13, and A2Q15.

4-19. AC feedback from the meter bridge to the feedback summing junction is adjustable at 4 MHz (A2C36) and 400 Hz (A2R62) on the 30 mV range. On the .1 mV range, A2R64, A2R67, and A2R68 are switched into the circuit to increase the gain of the amplifier by 10 dB and to allow a 400 Hz gain adjustment to be made.

4-20. DC feedback from the collector of A2Q15 to the feedback summing junction is adjustable at 20 Hz (A2R59) on the 30 mV range. A2R58 is switched into the circuit on the .1 mV range to provide a feedback adjustment at 30 Hz. These adjustments provide overall amplifier gain stability for the entire voltage and frequency range of the instrument.

4-21. A2Q14 isolates the AC OUTPUT circuit from the meter amplifier and the meter bridge. It is an independent current source which will supply a signal to the OUTPUT terminal that is identical to the signal applied to the meter bridge. That is, for a 1 V rms signal for full scale meter deflection, A2Q14 will provide a 1 V rms signal at the AC OUTPUT terminal.

4-22. Meter Bridge.

4-23. Refer to Figure 4-3 for a simplified diagram of the metering circuit.

4-24. The meter bridge is a full wave rectifier that converts the ac signal from the meter amplifier into dc. It supplies current to drive the meter and provides an ac feedback signal to the meter amplifier.

4-25. Transistor A2Q16 provides a large output impedance for the meter amplifier and is the current drive source for the meter bridge circuit. The collector output of A2Q16 is applied to the meter bridge and is rectified by diodes A2CR22 and A2CR23. The ac components of the bridge signal are coupled into the feedback loop by capacitors A2C38 and A2C39. A2Q17 bootstraps the resistance of A2R69 to a high value so that current is driven through the bridge. This bridge current maintains a linear meter circuit response to large signal amplitude variations.

4-26. The meter, M1, is a current driven device that utilizes a taut-band movement. It responds to the average value of the rectified meter amplifier output which is proportional to the rms value of the sinusoidal signal being measured. The meter indicates the rms value of the input voltage and the power level in dBm for resistive loads of 600 ohms. Measurements across loads other than 600 ohms will be

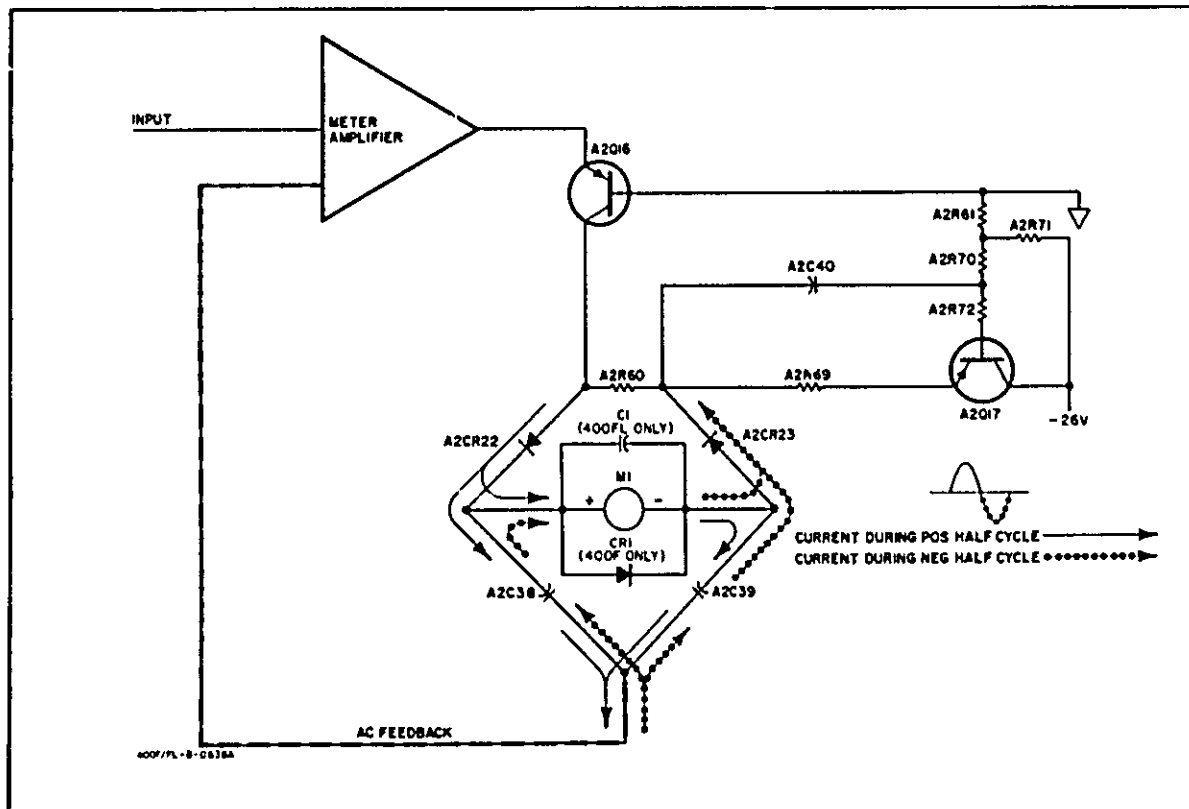

Figure 4-3. Simplified Diagram of Metering Circuit.

indicated in dB but not dBm. The meter is protected from circuit overloads by diode CR1 (400F) and capacitor C1 (400FL).

4-27. Power Supply.

4-28. The power supply provides both a positive and negative 26 V regulated output. It may be operated by external batteries (+35 V to 55 V and -35 V to 55 V) or line power (115 V or 230 V, 48 to 440 Hz).

4-29. The line input is converted to dc by a diode rectifier network consisting of A2CR6 through A2CR9. The positive output of the rectifier is applied to series regulator A2Q4,

which regulates the +26 V supply. Control transistor A2Q6 has a constant emitter reference voltage supplied by zener diode A2CR13. Capacitor A2C16 couples any change in the +26 V output to the base of A2Q6 which will supply a signal proportional to the change in output voltage to A2Q5. A2Q5 will then amplify the signal and couple it to the base of the regulator A2Q4, causing it to regulate the output by either increasing or decreasing conduction.

4-30. The -26 V supply is regulated in the same manner as the +26 V supply with one minor difference. The source of reference for the -26 V control transistor, A2Q7, is the +26 V output. The +26 V supply reference is provided by zener diode A2CR13 as described in Paragraph 4-29.

SECTION V MAINTENANCE

5-1. INTRODUCTION.

5-2. This section contains maintenance and service information for the Model 400F/FL AC Voltmeter. Included are Performance Tests, Alignment and Calibration Procedures, and Troubleshooting Procedures.

5-3. TEST EQUIPMENT REQUIRED.

5-4. The equipment required to properly maintain the 400F/FL is listed in Table 5-1. The table lists the type of equipment to be used, the specification requirements, and the recommended commercially available test equipment.

NOTE (400F only)

Before beginning the Performance Tests, mechanically zero the meter according to the procedures in Paragraph 3-5.

5-5. PERFORMANCE TESTS.

5-6. The following Performance Tests compare the Model 400F/FL with its accuracy specifications (Table 1-1). These tests may be used for incoming inspection, periodic maintenance, and for specification tests after a repair. A Performance Test Card is provided at the end of this section for recording the performance of the Model 400F/FL during the Performance Tests. The card can be removed from the manual and used as a permanent record of the incoming inspection or of a routine performance test.

5-7. A highly accurate and stable voltage reference that is variable from 20 Hz to 4 MHz is required for the Performance Tests. The -hp- Model 738BR Voltmeter Calibrator produces a 400 Hz signal that is within less than 0.2% of the indicated output. The -hp- Model 652A Test Oscillator can be referenced to the output of the Voltmeter Calibrator and can be adjusted to within 0.25% of the set reference voltage from 20 Hz to 4 MHz.

5-8. If the -hp- 652A Test Oscillator is not available, the -hp- 3320B Frequency Synthesizer can be used. The 3320B has a calibrated output from + 26.99 dBm to - 69.99 dBm with a frequency response of ± 0.05 dB over the range of 20 Hz to 4 MHz.

5-9. The following procedures specify the use of the -hp- 652A and the -hp- 738BR. If the -hp- 3320B Frequency Synthesizer is used, follow the same general procedures.

5-10. Figure 5-1 shows the test setup for using the -hp- 652A and -hp- 738BR combination. If the -hp- 3320B is used, it directly replaces the -hp- 652A in Figure 5-1.

NOTE

The 0.1 mV range of the 400F/FL may be checked for accuracy by verification of the additional 10 dB of gain that is provided by the meter amplifier on that range. In order to verify the gain, the top cover of the instrument must be removed to gain access to TP1 through TP4.

Table 5-1. Test Equipment.

AC Voltmeter Calibrator	Accuracy: 0.2% at 400 Hz Range: 30 mV to 1 V	Performance Tests and Calibration	-hp- Model 738BR Voltmeter Calibrator
Test Oscillator	Output: 30 mV to 1 V Frequency Range: 20 Hz to 4 MHz Distortion: < 1% Flatness: $\pm 0.25\%$	Performance Tests and Calibration	-hp- Model 652A Test Oscillator or -hp- Model 3320B
High Voltage Amplifier	Output: 100 μ V to 300 V Frequency Range: 10 Hz to 110 kHz	Performance Tests	-hp- Model 745A/746A
AC/DC Voltmeter/ Ohmmeter	Volts Accuracy: 2% Ohms Accuracy: 5%	Troubleshooting	-hp- Model 427A Voltmeter
Termination	Feedthrough: 50 ohm impedance	Performance Tests and Calibration	-hp- Model 11048C
Resistor	Fxd, 100 k Ω $\pm 1\%$	Performance Tests	-hp- Part No. 0757-0465
Resistor	Fxd, 1 k Ω $\pm 1\%$	Performance Tests	-hp- Part No. 0757-0338
Crystal Socket (with terminals shorted)	Size: 1/2 inch	Performance Tests and Calibration (Shorting Test Points)	-hp- Part No. 1200-0028

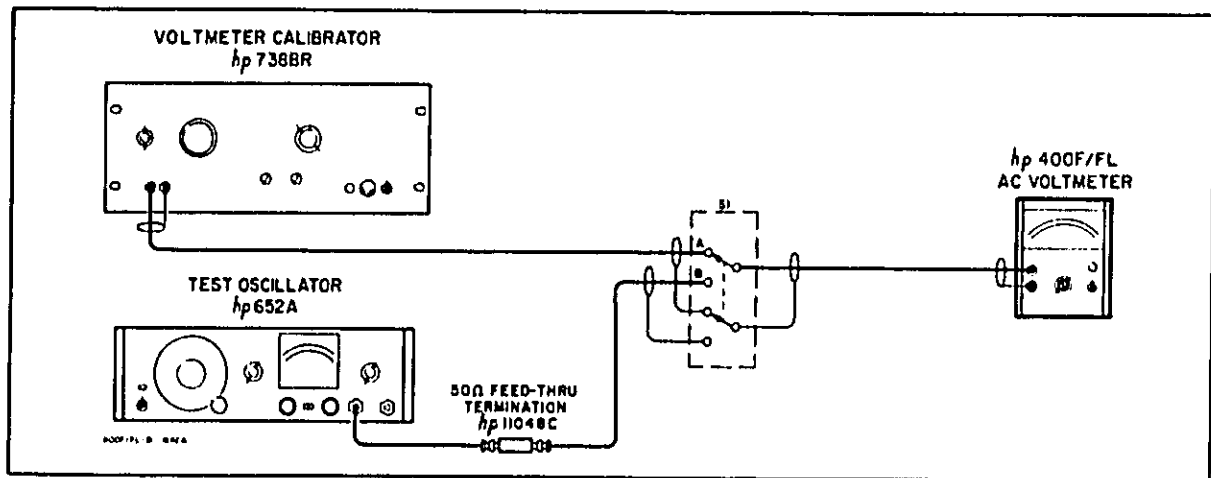

Figure 5-1. Accuracy and Frequency Response Test Setup.

5-11. Top Cover Removal.

5-12. To remove or replace the top cover, follow the procedures outlined in Paragraph 5-23.

5-13. Accuracy and Frequency Response Tests.

5-14. The accuracy and frequency response tests compare the Model 400F/FL with its accuracy specifications over the entire frequency range.

- Connect the voltmeter calibrator, test oscillator, and 50 ohm termination to the Model 400F/FL as shown in Figure 5-1. An external switch, S2, may be used to facilitate switching from one test instrument to the other.
- Set Model 400F/FL RANGE switch to 30 mV and set 100 kHz FILTER switch to OUT. Set switch S1 to A.
- Set voltmeter calibrator for a 30 mV rms output at 400 Hz.
- Observe the Model 400F/FL meter indication. If the meter indication is not within the tolerances listed in Table 5-2 for the 30 mV range at 400 Hz, perform the Meter

Calibration (Paragraph 5-31). If indication is within tolerance, record actual meter reading.

- Set Model 400F/FL RANGE switch to 100 mV. The meter should indicate 30 mV on 100 mV range.

- Remove top cover and short TP1 to TP4, and short TP2 to TP3. (A shorting device, such as a crystal socket with its terminals shorted together, should be used to avoid pickup of noise.) If the meter indication is not the same as the indication in Step d of this paragraph, perform the Meter Calibration (Paragraph 5-31). If the indication is within tolerance, record actual meter reading. This step verifies the accuracy of the additional 10 dB of gain provided by the meter amplifier on the 0.1 mV range.

- Disconnect shorts between test points and set Model 400F/FL RANGE switch to 1 volt.

- Set voltmeter calibrator for a 0.9 volt rms output at 400 Hz. Observe the Model 400F/FL meter indication. If the meter indication is not within the tolerances listed in Table 5-2 for 1 volt range at 400 Hz, perform the Meter Calibration (Paragraph 5-31). If the indication is within tolerance, record the actual meter reading.

Table 5-2. Full Scale Calibration Tolerances.

30 mV Range			100 mV Range (0.1 mV Range Test)			1 Volt Range		
Freq.	Meter Indication		Freq.	Meter Indication		Freq.	Meter Indication	
	Min.	Max.		Min.	Max.		Min.	Max.
20	28.8	31.2	30	28.8	31.2	20	0.86	0.94
40	29.4	30.6	60	29.4	30.6	40	0.88	0.92
400	29.7	30.3	400	29.4	30.6	400	0.89	0.91
1000	29.7	30.3	1000	29.4	30.6	1000	0.89	0.91
10 K	29.7	30.3	10 K	29.4	30.6	10 K	0.89	0.91
100 K	29.7	30.3	100 K	29.4	30.6	100 K	0.89	0.91
1 M	29.7	30.3	600 K	27.6	30.3	1 M	0.89	0.91
2 M	29.4	30.6				2 M	0.88	0.92
4 M	28.8	31.2				4 M	0.86	0.94

i. Set switch S1 to position B; set Model 400F/FL RANGE switch to 30 mV; and set test oscillator OUTPUT ATTENUATOR to 0.03 volt at 400 Hz.

j. Adjust test oscillator AMPLITUDE control for same meter indication on Model 400F/FL as recorded in Step d of this paragraph.

k. Set test oscillator MONITOR to EXPAND and adjust REF SET for a center scale meter reference. (Do not readjust REF SET once a reference is obtained.)

l. Check Model 400F/FL meter tolerances for all frequencies listed in Table 5-2 (30 mV range). Adjust test oscillator AMPLITUDE control to maintain meter reference for each frequency.

m. Set test oscillator MONITOR to NORMAL and OUTPUT ATTENUATOR to 0.03 volt range. Set Model 400F/FL to 100 mV RANGE and short TP1 to TP4 and short TP2 to TP3.

n. Adjust test oscillator AMPLITUDE control for same meter indication on Model 400F/FL as recorded in Step f of this paragraph.

o. Repeat Steps k and l for the 100 mV range of Table 5-2.

p. Remove shorting devices, set Model 400F/FL to 1 volt RANGE, and set test oscillator MONITOR to NORMAL.

q. Set test oscillator OUTPUT ATTENUATOR to 1 volt range at 400 Hz and adjust test oscillator AMPLITUDE control for same meter indication on Model 400F/FL as recorded in Step h of this paragraph.

r. Repeat Steps k and l for 1 volt range of Table 5-2.

5-15. Range Tracking Test.

5-16. After verifying the 400F/FL full scale calibration with the accuracy and frequency response tests, check the range tracking of the instrument with the following procedures. Use the test setup shown in Figure 5-1 for the range tracking check.

- a. Set switch S1 to Position B.
- b. Set 400F/FL RANGE switch to 30 mV.
- c. Adjust test oscillator for a 400F/FL meter indication of 30 mV at 400 Hz.
- d. Set 400F/FL RANGE switch to 100 mV. 400F/FL should indicate 30 mV \pm 2.2%.
- e. Set 400F/FL RANGE switch to 0.3 volts.
 - 1. 400F should indicate 30 mV \pm 5.5%.
 - 2. 400FL cannot be checked with a 1/10 scale input.

f. Adjust test oscillator for a 400F/FL meter indication of 30 mV at 1 MHz.

g. Set 400F/FL RANGE switch to 100 mV. 400F/FL should indicate 30 mV \pm 2.2%.

h. Set 400F/FL RANGE switch to 0.3 volts.

1. 400F should indicate 30 mV \pm 5.5%

2. 400FL cannot be checked with a 1/10 scale input.

5-17. Noise and Filter Test.

a. A shielded 1 k Ω resistor and an ac voltmeter are required for this test.

NOTE

Figure 5-2 lists the parts and shows the construction of the 1 k Ω shielded resistor.

b. Connect the shielded 1 k Ω resistor across the Model 400F/FL INPUT terminals. Connect the ac voltmeter to the AC OUTPUT terminals on rear panel of Model 400F/FL.

c. Observe the Model 400F/FL AC OUTPUT on the ac voltmeter with RANGE and FILTER settings listed in Table 5-3.

d. Noise should not exceed the levels given in Table 5-3. This verifies the noise specification referred to a 1000 ohm terminated input.

Table 5-3. Noise Level Specifications.

400F/FL Range	400F/FL AC Output	
	Filter In	Filter Out
100 μ V	\leq 50 mV	\leq 150 mV
300 μ V to 300 V	\leq 17 mV	\leq 100 mV

5-18. Input Impedance Test.

5-19. Input Resistance Test.

- a. Set the test oscillator to 400 Hz and connect the 50 Ω output to 400F/FL.
- b. Set 400F/FL RANGE switch to 1 volt.
- c. Set test oscillator output for full scale deflection of 400F/FL.
- d. Connect a 100 k Ω resistor between test oscillator and 400F/FL as shown in Figure 5-3.
- e. 400F/FL meter indication should not drop more than one small scale division from full scale. This verifies an input resistance of 10 M Ω .

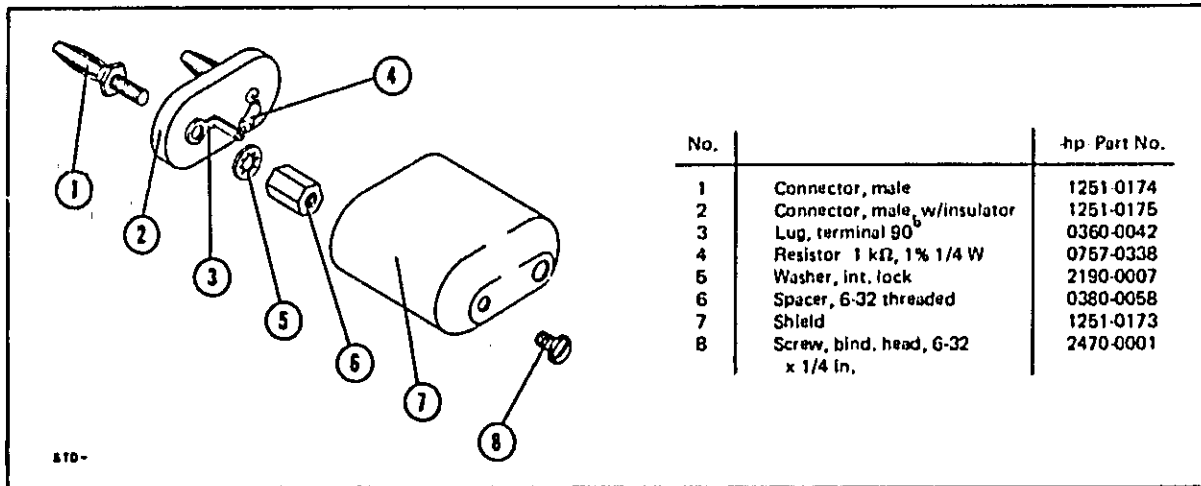

Figure 5-2. 1 kΩ Shielded Resistor.

5-20. Input Capacity Test.

a. Connect test oscillator and a 100 kΩ resistor to 400F/FL as shown in Figure 5-3. Connect the resistor lead directly to the GR connector.

b. Set 400F/FL RANGE switch to 1 volt.

c. Set test oscillator output for full scale deflection of 400F/FL meter at 400 Hz.

d. Increase frequency of test oscillator until 400F/FL indication drops to 0.707 volts. This should occur at a frequency of 106 kHz or greater, verifying an input capacity of 15 pF or less on the 1 volt range.

e. Set 400F/FL RANGE switch to 300 mV.

f. Set frequency response test set output for an indication of 300 mV on the 400F/FL meter at 400 Hz.

g. Increase frequency of test oscillator until 400F/FL indication drops to 212 mV. This should occur at a frequency of 53 kHz or greater, verifying an input capacity of 30 pF or less on the 300 mV range.

5-21. ALIGNMENT AND CALIBRATION PROCEDURES.

5-22. The Alignment and Calibration Procedures should be performed only if it has been determined by the Performance Tests that the 400F/FL is not within specifications. The following procedures specify the use of an -hp- 738BR Voltmeter Calibrator and an -hp- 652A Test Oscillator. However, an -hp- 3320B Frequency Synthesizer may be substituted by following the same general procedures. If the instrument cannot be properly adjusted, refer to Paragraph 5-40, Troubleshooting Procedures. Refer to Figure 5-4 for the location of internal adjustments.

5-23. Cover Removal and Replacement.

5-24. Removal of the top cover exposes circuit areas for routine checks and adjustments. Removal of the bottom and side covers exposes circuit areas for operations such as soldering and component replacement.

5-25. Top or Bottom Covers.

a. Remove screws securing cover. Slide cover about 1 inch to rear, and lift it off.

b. To replace cover, reverse the removal procedure.

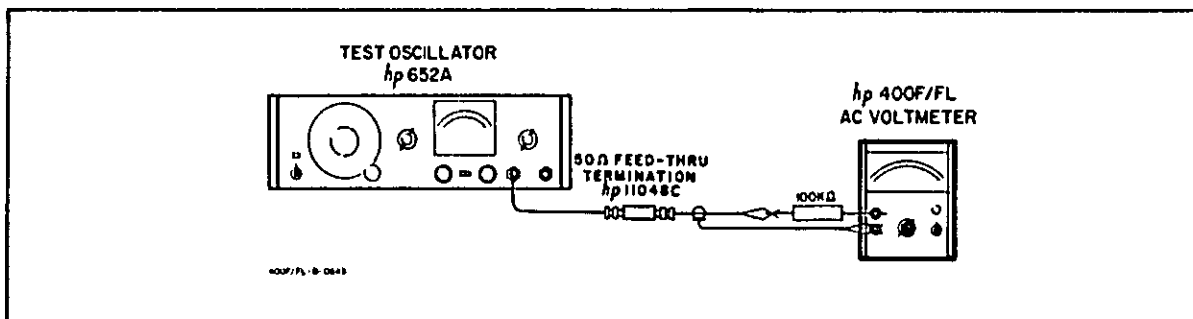

Figure 5-3. Input Impedance Test Setup.

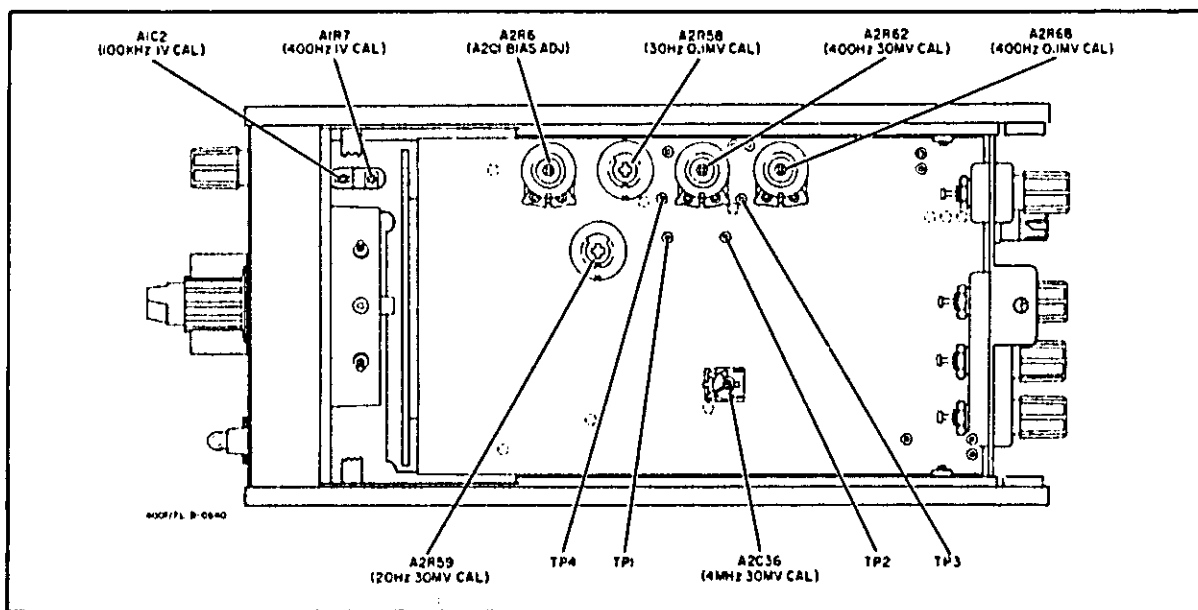

Figure 5-4. Location of Internal Adjustments.

5-26. **Side Cover.** Remove the four screws from side cover, and lift it off.

5-27. Meter Mechanical Zero Adjustment.

5-28. Refer to Paragraph 3-5 for the meter mechanical zero adjustment procedures.

5-29. A2Q1 Bias Adjustment.

5-30. A2R6 provides a bias adjustment for field effect transistor A2Q1.

a. Monitor voltage at junction between A2R5 and A2R3 with a dc voltmeter.

b. Adjust A2R6 for a +6 V indication at the junction. See APPENDIX C, CHANGE #2.

5-31. Meter Calibration.

5-32. The following procedures are used to adjust the gain of the meter amplifier on two voltage ranges at five different frequencies. Proper gain adjustments will assure accurate meter indications over the entire voltage and frequency range of the instrument. Use the test setup shown in Figure 5-1 for the meter calibration.

5-33. Meter Calibration, 30 mV Range.

- Set switch S1 to Position A.
- Set 400F/FL RANGE switch to 30 mV, and set 100 kHz L.P. FILTER switch to OUT.
- Set voltmeter calibrator for 30 mV output at 400 Hz.

d. Adjust A2R62 for a 400F/FL meter indication of 30 mV.

e. Set switch S1 to Position B.

f. Adjust test oscillator for a 400F/FL meter indication of 30 mV at 400 Hz. Set a reference on meter of test oscillator and use amplitude control to maintain reference whenever frequency of oscillator is changed.

g. Set test oscillator to 20 Hz, maintaining amplitude at 30 mV.

h. Adjust A2R59 for a 400F/FL meter indication of 30 mV.

i. Set test oscillator to 4 MHz, maintaining amplitude at 30 mV.

j. Adjust A2C36 for a 400F/FL meter indication of 30 mV.

5-34. Meter Calibration, 0.1 mV Range.

NOTE

The 0.1 mV range meter calibration is performed on a higher range. This is done by shorting test points which provide the amplifier with the additional 10 dB of gain that normally is switched in only on the 0.1 mV range.

a. Set switch S1 to Position B.

b. Set 400F/FL RANGE switch to 30 mV, and set 100 kHz L.P. FILTER switch to OUT.

c. Adjust test oscillator for a 400F/FL meter indication of 30 mV at 400 Hz.

d. Set 400F/FL RANGE switch to 100 mV.

e. Short TP1 to TP4 and short TP2 to TP3. (This increases the gain of the meter amplifier by 10 dB, as if the instrument were on the 0.1 mV range.)

f. Adjust A2R68 for a 400F/FL meter indication of 30 mV. (Although the 400F/FL RANGE switch is in the 100 mV position, the instrument effectively is still on the 30 mV range.)

g. Set test oscillator to 30 Hz, maintaining amplitude at 30 mV.

h. Adjust A2R58 for a 400F/FL meter indication of 30 mV.

5-35. Attenuator Alignment.

5-36. The following procedures are used to properly align the input attenuator of the 400F/FL at both high and low frequencies. Use the test setup shown in Figure 5-1 for the attenuator alignment.

a. Set switch S1 to Position A.

b. Set 400F/FL RANGE switch to 1 volt, and set 100 kHz L.P. FILTER switch to OUT.

c. Adjust voltmeter calibrator for a 1 volt output at 400 Hz.

d. Adjust A1R7 for a 400F/FL meter indication of 1 volt.

e. Set switch S1 to Position B.

f. Set test oscillator for a 400F/FL meter indication of 1 volt at 400 Hz.

g. Set test oscillator to 100 kHz, maintaining the amplitude at 1 volt.

h. Adjust A1C2 for a 400F/FL meter indication of 1 volt. If more than a 1% adjustment is needed, repeat the 400 Hz adjustment.

5-37. Replacement of A2C37*.

5-38. The value of A2C37 is individually selected to compensate for varying circuit parameters within the instrument. Certain Model 400F/FL instruments may not have a capacitor in this location.

5-39. If an instrument cannot be properly calibrated on the 30 mV range at 4 MHz, A2C37 should be changed. Increase the value of A2C37 if the instrument meter indication is high and cannot be adjusted low enough. Decrease the value

of A2C37 if the instrument meter indication is low and cannot be adjusted high enough.

5-40. TROUBLESHOOTING PROCEDURE.

5-41. The following paragraphs are included as an aid to troubleshooting the Model 400F/FL. No attempt is made in these tests to measure every circuit parameter but to provide guidelines for localizing a malfunction. Read Section IV for an understanding of circuit operation before attempting to do any troubleshooting.

5-42. When the Model 400F/FL is suspected of faulty operation perform the Alignment and Calibration Procedures in Paragraph 5-21. The malfunction may be no more than an adjustment out of tolerance. Usually the Alignment and Calibration Procedure will assist in localizing the trouble, whether it is an adjustment or a defective component.

5-43. Visually inspect the Model 400F/FL for any indication of a mechanical or electrical failure. Check for broken or loose connectors or wires, and charred or discolored components. Look for anything unusual that may indicate a malfunction.

5-44. Refer to Table 5-4 for a list of trouble symptoms and the possible cause.

5-45. Power Supply.

5-46. The Model 400F/FL has a + 26 V power supply and a - 26 V power supply. It is important to remember that the - 26 V supply is referenced to the + 26 V supply. Troubleshoot the - 26 V supply only after it has been ascertained that the + 26 V supply is operating properly.

5-47. Both supplies have a jumper wire that can be lifted to disconnect the load. If a supply should read low, lift the jumper wire and measure the voltage. If the voltage returns to normal, load the supply with a 560 Ω resistor. If the voltage drops, the problem is internal to the power supply. Troubleshoot the supply using Figure 7-3. If the voltage remains normal with the 560 Ω load, the problem is external to the supply. Troubleshoot the external circuit.

5-48. Preamplifier.

5-49. When operating normally the Preamplifier has a gain of 10 dB. With a 1 volt, 400 Hz, rms input on the 1 V RANGE of the Model 400F/FL, a 1 mV signal will be present at A2R17. Measure the signal at A2R17. If it is 1 mV, measure the signal at A2C4. For 10 dB of gain the signal amplitude at A2C4 should be 3.16 mV. Troubleshoot the Preamplifier using the dc voltages shown on the schematic diagram, Figure 7-3, if the signal at A2C4 does not measure 3.16 mV.

5-50. Measure the + 6 V bias at A2R8. If the + 6 V bias is low and cannot be adjusted with A2R6, BIAS ADJ, check for an open A2L1, A2L2 or A2Q1. Also check A2Q2 and

Table 5-4. Front Panel Troubleshooting Guide.

Symptom	Possible Cause
Inoperative on 0.1 mV RANGE through 0.3 V RANGE.	Relay A2K1 stuck open or stuck closed.
Inoperative on 1 V RANGE through 300 V RANGE.	Relay A2K1 stuck closed or A2K2 stuck open.
Meter deflection on all ranges with no input	Check A2Q15, A2Q16, A2Q17, A2C38, A2C39, and A2C40.
Meter remains at zero, on all ranges, with any input.	Check CR1 (400F only) or C1 (400FL only) for a short. Check A2CR22 and A2CR23.
Meter is erratic and/or inaccurate on all ranges.	Check +26 volt and -26 volt supplies. Check A2Q11, A2Q16 and A2Q17.
Meter is erratic and/or inaccurate on high sensitivity ranges.	Check RANGE switch contacts (S1) and A2Q1.
Meter reads low with 4 MHz input.	Check S1CR1, S1CR2, A2CR3, and A2CR16.
Meter reads low with 2 MHz input.	Check A2C10 and A2R44.
Excessive noise.	Check A2Q1 and A2R60.
Meter pegs.	C36 is shorted rotor to stator.
Meter reads high on most sensitive ranges.	Ground loops.

A2Q3 for a short. If the +6 V bias is high, check for an open A2Q2 or A2Q3. Use the dc voltages shown on the schematic diagram, Figure 7-2, to aid in isolating a faulty component.

5-51. Meter Amplifier.

5-52. When the meter needle fails to deflect with a signal input, the problem may be a faulty transistor in the Meter Amplifier. Measure the dc voltages shown on the schematic diagram, Figure 7-2, to isolate a faulty component in the Meter Amplifier. Often a problem in the Meter Amplifier will also cause erroneous dc voltage readings in the Meter Bridge.

5-53. If A2Q14 and associated circuitry are not operating properly, it may alter the performance of the Meter Amplifier to make it appear that the Meter Amplifier is at fault. Check A2Q14 and associated circuitry when the Meter Amplifier is suspected of faulty operation.

5-54. Meter Bridge.

5-55. Measure the voltage at the collector of A2Q16. The voltage should read -9 V. If the voltage is -18 V, check A2CR23. When the voltage at the collector of A2Q16 is -18 V the meter needle will remain pegged below zero with any input. If the voltage at the collector of A2Q16 is 0 V, check A2CR22. When the voltage reading is 0 V the Model 400F/FL meter needle will remain at zero with any input.

5-56. ETCHED CIRCUIT BOARD REPAIR.

5-57. The Model 400F/FL uses plated through, double-sided, etched circuit boards. To prevent damage to the

circuit board and components, observe the following rules when soldering:

- a. Use a low-heat (25 to 50 watts) soldering iron with a small tip (1/16" to 3/32" diameter).



Excessive or prolonged heat can lift the circuit foil from the board or cause damage to components.

- b. To remove a component, clip a heat sink (long nose pliers, commercial heat sink tweezers, etc.) on the component lead as close to the component as possible. Place the soldering iron directly on the component lead, and pull up on the lead. If a component is obviously damaged or faulty, clip the leads close to the component and then remove the leads from the board.

- c. Clean the component lead holes by heating the solder in the hole, quickly removing the soldering iron, and inserting a pointed, non-metallic object such as a toothpick.

- d. To mount a new component, shape the leads and insert them in the holes. Clip a heat sink on the component, heat with the soldering iron, and add solder as necessary to obtain a good electrical connection.

- e. Clip excess leads off after soldering and clean excess flux from the connection and adjoining area, using Green Soldering Aid, -hp- Part No. 8710-0038.

PERFORMANCE TEST CARD

Hewlett-Packard Model 430F/FL
AC Voltmeter
Serial No. _____

Test performed by _____
Date _____

DESCRIPTION	TEST		
Accuracy and Frequency Response:			
30 mV Range	Min.	Meter Indication	Max.
20 Hz	28.8	_____	31.2
40 Hz	29.4	_____	30.6
400 Hz	29.7	_____	30.3
1000 Hz	29.7	_____	30.3
10 kHz	29.7	_____	30.3
100 kHz	29.7	_____	30.3
1 MHz	29.7	_____	30.3
2 MHz	29.4	_____	30.6
4 MHz	28.8	_____	31.2

DESCRIPTION	TEST		
100 mV Range (0.1 mV Range Test)	Min.	Meter Indication	Max.
30 Hz	28.8	_____	31.2
60 Hz	29.4	_____	30.6
400 Hz	29.4	_____	30.6
1000 Hz	29.4	_____	30.6
10 kHz	29.4	_____	30.6
100 kHz	29.4	_____	30.6
500 kHz	27.6	_____	30.3

DESCRIPTION	TEST		
1 V Range	Min.	Meter Indication	Max.
20 Hz	0.86	_____	0.94
40 Hz	0.88	_____	0.92
400 Hz	0.89	_____	0.91
1000 Hz	0.89	_____	0.91
10 kHz	0.89	_____	0.91
100 kHz	0.89	_____	0.91
1 MHz	0.89	_____	0.91
2 MHz	0.88	_____	0.92
4 MHz	0.86	_____	0.94

DESCRIPTION	TEST		
Range Tracking:			
400 Hz	Min.	Meter Indication	Max.
100 mV	400F/FL 29.35	_____	30.65
0.3 V	400F 28.35	_____	31.65
	400FL	No indication at 1/10 scale	
1 MHz	Min.	Meter Indication	Max.
100 mV	400F/FL 29.35	_____	30.65
0.3 V	400F 28.35	_____	31.65
	400FL	No indication at 1/10 scale	

DESCRIPTION	TEST	
Noise and Filter Test		
	AC Output	
0.3 mV FILTER IN	17 mV or less	_____
0.3 mV FILTER OUT	100 mV or less	_____
0.1 mV FILTER IN	50 mV or less	_____
0.1 mV FILTER OUT	150 mV or less	_____

DESCRIPTION	TEST	
Input Impedance:		
	Meter Indication	
Resistance	10 MΩ or greater	_____
Capacity	15 pF or less on 1 V range	_____
	30 pF or less on 300 mV range	_____

SECTION VI REPLACEABLE PARTS

6-1. INTRODUCTION.

6-2. This section contains information for ordering replacement parts. Table 6-1 lists parts in alphameric order of their reference designators and indicates the description, hp-part number of each part, together with any applicable notes, and provides the following:

- a. Description of the part. (See list of abbreviations below.)
- b. Typical manufacturer of the part in a five-digit code. (See Appendix A for list of manufacturers.)
- c. Manufacturer's part number.
- d. Total quantity used in the instrument (TQ column). Total quantity of a part is given the first time the part number appears.

6-3. Miscellaneous parts are listed at the end of Table 6-1.

6-4. ORDERING INFORMATION.

6-5. To obtain replacement parts, address order or inquiry to your local Hewlett-Packard Field Office. (See Appendix B for list of office locations.) Identify parts by their Hewlett-Packard part numbers.

6-6. NON-LISTED PARTS.

6-7. To obtain a part that is not listed, include:

- a. Instrument model number.
- b. Instrument serial number.
- c. Description of the part.
- d. Function and location of the part.

		ABBREVIATIONS			
Ag	silver	Hz	hertz cycle(s) per second	NPO	negative positive zero (zero temperature coefficient)
Al	aluminum	ID	inside diameter	na	nanosecond(s) = 10 ⁻⁹ second
A	ampere(s)	imp	impregnated	nr	not necessarily replaceable
Au	gold	incd	incandescent	Ω	ohm(s)
C	capacitor	ins	insulation(s)	ohl	order by description
ce	ceramic	int	integrated	OD	outside diameter
coef.	coefficient	in	inch	p	peak
com.	common	lin	linear	pA	picampere(s)
comp.	composition	log	logarithmic	pc	printed circuit
conn.	connection	log	logarithmic taper	pF	picofarad(s) 10 ⁻¹² farad
dep.	deposited	mA	milliampere(s) = 10 ⁻³ ampere	p/o	part of
DPDT	double pole double throw	MHz	megahertz = 10 ⁶ hertz	pos	position
DPST	double pole single throw	MΩ	megohm(s) = 10 ⁶ ohm	poly	polystyrene
EMT	electrolytic	met film	metal film	pot	potentiometer
enrap	encapsulated	mfr	manufacturer	p/p	peak to peak
F	farad(s)	ms	millisecond	ppm	parts per million
FET	FET effect transistor	mg	milligram	prec	precision (temperature coefficient, long term stability and/or tolerance)
fsd	full scale deflection	mV	millivolt(s) = 10 ⁻³ volt	R	resistor
GAAs	gallium arsenide	μF	microfarad(s)	Rh	rhodium
GHz	gigahertz = 10 ⁹ hertz	J/V	microvolt(s) = 10 ⁻⁶ volt	rms	root mean square
gf	guard	my	Mylar®	rot	rotary
Ge	germanium	NA	nanampere(s) = 10 ⁻⁹ ampere	Se	selenium
gnd	ground(s)	NC	normally closed	sect	section(s)
H	henry (ind)	Ne	neon	Si	silicon
Hg	mercury	NO	normally open		

DECIMAL MULTIPLIERS					
Prefix	Symbol	Multiplier	Prefix	Symbol	Multiplier
tera	T	10 ¹²	centi	c	10 ⁻²
giga	G	10 ⁹	milli	m	10 ⁻³
mega	M or Meg	10 ⁶	micro	μ	10 ⁻⁶
kilo	K or k	10 ³	nano	n	10 ⁻⁹
hecto	h	10 ²	pico	p	10 ⁻¹²
deka	da	10	femto	f	10 ⁻¹⁵
deci	d	10 ⁻¹	atto	a	10 ⁻¹⁸

DESIGNATORS			
A	assembly	FL	filter
B	motor	HR	heater
BT	battery	IC	integrated circuit
C	capacitor	J	jack
CR	diode	K	relay
DL	delay line	L	inductor
DS	lamp	M	meter
E	elec. electronic part	MP	mechanical part
F	fuse	P	plug
		Q	transistor
		OCR	transistor oxide
		R	resistor
		RT	thermistor
		S	switch
		T	transformer
		TB	terminal board
		TC	thermocouple
		TP	test point
		TS	terminal strip
		U	microcircuit
		V	vacuum tube, neon bulb, photocell, etc.
		W	wire
		X	connector
		XDG	lampholder
		XF	fuseholder
		Y	crystal
		Z	network

STD B 2734

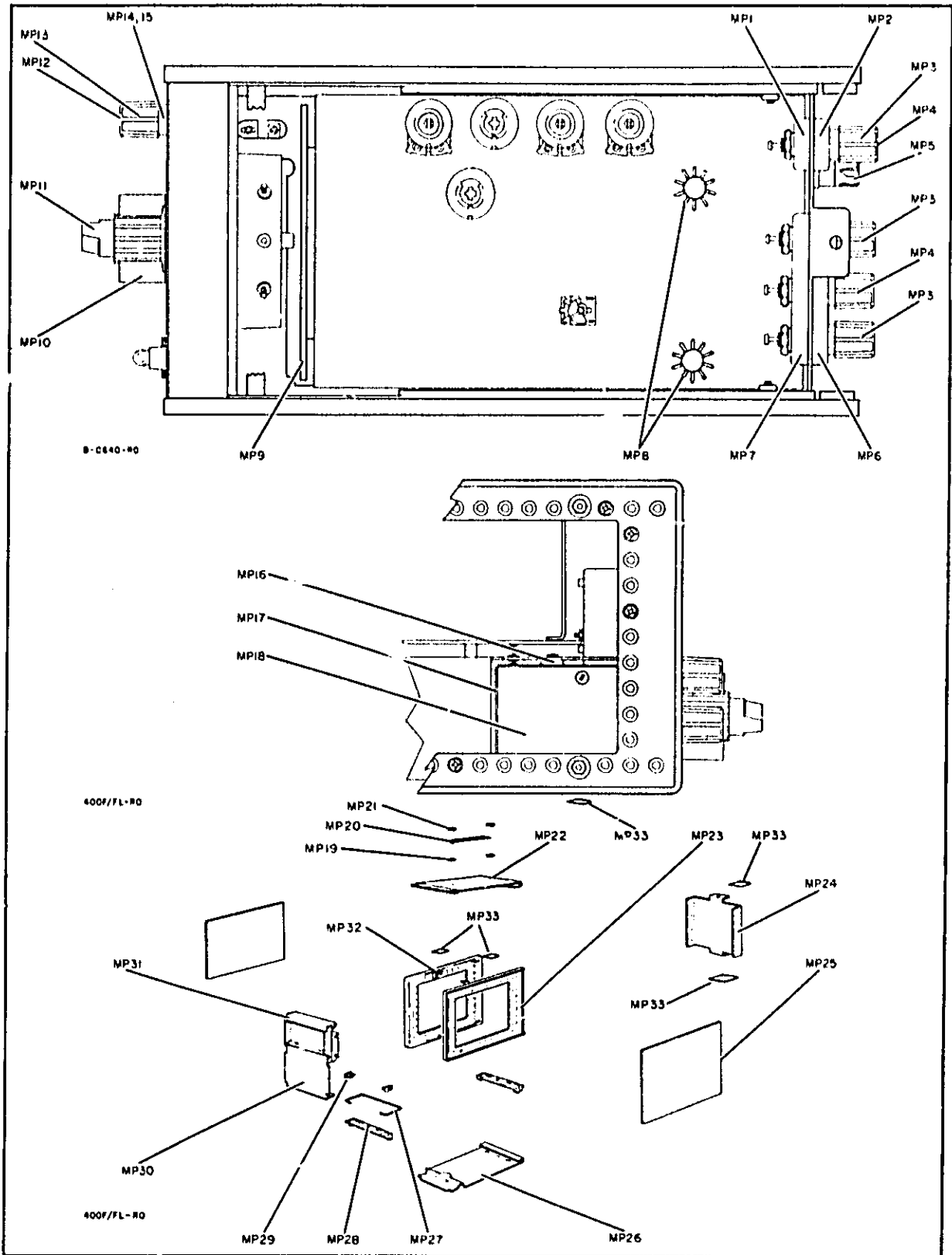

Figure 6-1. Location of Important Mechanical Parts.

Table 6-1. Replaceable Parts

REFERENCE DESIGNATOR	-hp- PART NO.	TQ	DESCRIPTION	MFR	MFR. PART NO.
A1	00400-66505	1	Assembly: board etched circuit includes C1 through C6 K1 through K2 R1 through R7	-hp-	
A1C1	0150-0012	1	C: fxd cer 0.01 μ F $\pm 20\%$ 1000 vdcw	56289	29C214A3
A1C2	0121-0407	1	C: var trimmer 0.7 to 3.0 pF	72982	536-016
A1C3	0150-0093	2	C: fxd 0.01 μ F $\pm 80\%$ -20% 100 vdcw	91418	TA obd
A1C4	0140-0179	1	C: fxd mica 1000 pF $\pm 2\%$	04062	RDM
A1C5	0140-0156	1	C: fxd mica 1500 pF $\pm 2\%$	04062	RDM10F152G3C
A1C6	0150-0093		C: fxd 0.01 μ F $\pm 80\%$ -20% 100 vdcw	91418	TA obd
A1K1	0490-0478	1	Relay: reed high voltage	-hp-	
A1K2	0490-0343	1	Relay: reed low voltage	-hp-	
A1R1	0757-0346	2	R: fxd prec met flm 10 ohms $\pm 1\%$ 1/8 W	91637	MFF 1/8 T-O obd
A1R2	0698-4128	1	R: fxd prec met flm 10M $\pm 0.25\%$	03888	PME 70-T-2
A1R3	0684-2211	2	R: fxd comp 220 ohms $\pm 10\%$ 1/4 W	01121	CB-2211
A1R4	0698-4475	1	R: fxd prec met flm 9.76 k Ω $\pm 1\%$ 1/8 W	91337	MFF 1/8 T-O obd
A1R5	0683-0625	1	R: fxd comp 6.2 ohms $\pm 5\%$ 1/4 W	01121	CB-62G5
A1R6	0684-2211		R: fxd comp 220 Ω $\pm 10\%$ 1/4 W	01121	CB-2211
A1R7	2100-1799	1	R: var ww 500 Ω $\pm 10\%$ 1 W	02660	2600 Series
A2	00400-66504	1	Assembly: board etched circuit includes C1 through C12 CR19-CR26, CR28 C15 through C34 L1, L2 C36 through C41 Q1 through Q17 CR1 through CR13 R1 through R18 CR16 R20 through R75	-hp-	
A2C1	0180-0100	10	C: fxd Ta 4.7 μ F $\pm 10\%$ 35 vdcw	56289	1500475X9035B2
A2C2	0150-0122	3	C: fxd 0.002 μ F $\pm 20\%$ 500 vdcw	72982	801-000-Y55-202M
A2C3	0180-0119	1	C: fxd Al elect 1 μ F $\pm 75\%$ -10% 25 vdcw	56289	30D105G025BA2- DSM
A2C4	0180-0137	2	C: fxd Ta elect 100 μ F $\pm 20\%$ 10 vdcw	56289	150D107X0010R2
A2C5	0150-0084	1	C: fxd cer 0.1 μ F $\pm 80\%$ -20% 50 vdcw	56289	33C41 obd
A2C6	0160-2024	1	C: fxd 75 pF $\pm 5\%$ 500 vdcw	00853	obd
A2C7	0180-0106		C: fxd Ta elect 60 μ F $\pm 20\%$ 6 vdcw	56289	150D606X0006B2
A2C8	0180-0100		C: fxd Ta 4.7 μ F $\pm 10\%$ 35 vdcw	56289	1500475X9035B2
A2C9	0140-0198	1	C: fxd mica 200 pF $\pm 5\%$ 300 vdcw	04062	RDM15F201J3C
A2C10	0180-0100		C: fxd Ta 4.7 μ F $\pm 10\%$ 35 vdcw	56289	1500475X9035B2
A2C11	0150-0122		C: fxd 0.002 μ F $\pm 20\%$ 500 vdcw	72982	801-000-Y55-202M
A2C12	0180-0100		C: fxd Ta 4.7 μ F $\pm 10\%$ 35 vdcw	56289	1500475X9035B2
A2C13, A2C14			Not assigned		
A2C15	0180-0061	3	C: fxd Al elect 100 μ F $\pm 75\%$ -10% 15 vdcw	56289	30D107G015DC2- DSM
A2C16	0180-0100		C: fxd Ta 4.7 μ F $\pm 10\%$ 35 vdcw	56289	1500475X9035B2
A2C17	0180-1819	2	C: fxd Al elect 100 μ F $\pm 75\%$ -10% 50 vdcw	56289	30D107G050DH2- DSM
A2C18	0150-0024	2	C: fxd cer 0.02 μ F $\pm 80\%$ -20% 600 vdcw	72982	841-000-25U-203Z
A2C19	0180-0100		C: fxd Ta 4.7 μ F $\pm 10\%$ 35 vdcw	56289	1500475X9035B2
A2C20	0180-0061		C: fxd Al elect 100 μ F $\pm 75\%$ -10% 15 vdcw	56289	30D107G015DC2- DSM
A2C21	0180-1819		C: fxd Al elect 100 μ F $\pm 75\%$ -10% 50 vdcw	56289	30D107G050DH2- DSM
A2C22	0150-0024		C: fxd cer 0.02 μ F $\pm 80\%$ -20% 600 vdcw	72982	841-000-25U-203Z
A2C23	0180-0061		C: fxd Al elect 100 μ F $\pm 75\%$ -10% 15 vdcw	56289	30D107G015DC2- DSM
A2C24, A2C25	0180-0100		C: fxd Ta 4.7 μ F $\pm 10\%$ 35 vdcw	56289	1500475X9035B2
A2C26	0180-0058	1	C: fxd Al elect 50 μ F $\pm 75\%$ -10% 25 vdcw	56289	30D506G025CC2- DSM

Table 6-1. Replaceable Parts (Cont'd)

REFERENCE DESIGNATOR	-hp- PART NO.	TQ	DESCRIPTION	MFR.	MFR. PART NO.
A2C27	0150-0122		C: fxd 0.002 μ F $\pm 20\%$ 500 vdcw	72982	801-000-Y55-202M
A2C28	0140-0195	1	C: fxd mica 130 pF $\pm 5\%$ 300 vdcw	04062	RDM15F131J3C
A2C29	0140-0190	1	C: fxd mica 39 pF $\pm 5\%$	04062	RDM15E390J3C
A2C30	0180-0224	1	C: fxd Al elect 10 μ F 15 vdcw	56289	30D106G015BA4
A2C31	0140-0208	1	C: fxd mica 680 pF $\pm 5\%$ 300 vdcw	04062	RDM15F681J3C
A2C32, A2C33	0180-0137		C: fxd Ta elect 100 μ F $\pm 20\%$ 10 vdcw	56289	150D107X0010R2
A2C34	0180-0100		C: fxd Ta 4.7 μ F $\pm 10\%$ 35 vdcw	56289	1500475X9035B2
A2C35			Not assigned		
A2C36	0121-0127	1	C: var 1.7 to 11 pF single section	74970	189-5-5
A2C37*	0140-0201	1	C: fxd mica 12 pF $\pm 5\%$ 500 vdcw	72136	RDM15C120J5C
A2C38, A2C39	0180-0393	2	C: fxd Ta 39 pF $\pm 10\%$ 10 vdcw	56289	150D396XJ010B2
A2C40	0180-0100		C: fxd Ta 4.7 μ F $\pm 10\%$ 35 vdcw	56289	1500475X9035B2
A2C41	0140-0149	1	C: fxd mica 470 pF $\pm 5\%$ 300 vdcw	04062	DM15F471J
A2CR1	1902-0022	2	Diode: breakdown 2.67V $\pm 10\%$ 4 mW	07910	CD35540
A2CR2	1901-0044	2	Diode: Si 50 mA at +1V 10 na reverse current 50 wiv 2 pF	07910	obd
A2CR3	1901-0040	15	Diode: Si 30 mA at +10 V piv 12 pF 2 ns	07910	CD6310 obd
A2CR4	1901-0044		Diode: Si 50 mA at +1 V 10 na reverse current 50 wiv 2 pF	07910	obd
A2CR5	1902-0022		Diode: breakdown 2.67V $\pm 10\%$ 4 mW	07910	CD35540
A2CR6 through A2CR11	1901-0033	6	Diode: Si 100 mA at 1 V 180 piv 1N485B	93332	D6238 obd
A2CR12	1901-0040		Diode: Si 30 mA at +10V piv 12 pF 2 ns	07910	CD6310 obd
A2CR13	1902-3125	1	Diode: Si 6.98 V $\pm 2\%$ 400 mW	07263	obd
A2CR14, A2CR15			Not assigned		
A2CR16	1901-0040		Diode: Si 30 mA at +10V piv 12 pF 2 ns	07910	CD6310 obd
A2CR17, A2CR18			Not assigned		
A2CR19 through A2CR21	1901-0040		Diode: Si 30 mA at +10V piv 12 pF 2 ns	07910	CD6310 obd
A2CR22, A2CR23	1901-0518	2	Diode: Hot Carrier	-hp-	obd
A2CR24, 25, 26	1901-0040		Diode: Si 30 mA at 30 wiv 2 pF 2 ns	07910	CD6310 obd
A2CR27			Not assigned		
A2CR28	1901-0040		Diode: Si 30 mA at 30 wiv 2 pF 2 ns	07910	CD6310 obd
A2L1, A2L2	9140-0047	2	Inductor: fxd 20 μ H $\pm 10\%$	99848	H 51074020
A2Q1	1855-0033	1	TSTR: Si FET N channel	17856	FN 576
A2Q2	1853-0036	7	TSTR: Si PNP 2N3906	04713	2N3906-5
A2Q3	1854-0314	1	TSTR: Si NPN 310 mW 320 MHz	04713	MPS6521
A2Q4	1854-0039	2	TSTR: Si NPN 2N3052	86684	2N3053
A2Q5, A2Q6	1854-0215	6	TSTR: Si NPN 2N3904	04713	2N3904
A2Q7, A2Q8	1853-0036	6	TSTR: Si PNP 2N3906	04713	2N3906
A2Q9	1854-0039		TSTR: Si NPN 2N3053	86684	2N3053
A2Q10	1854-0215		TSTR: Si NPN 2N3904	04713	2N3904
A2Q11	1853-0036		TSTR: Si PNP 2N3906	04713	2N3906
A2Q12 through A2Q14	1854-0215		TSTR: Si NPN 2N3904	04713	2N3904
A2Q15 through A2Q17	1853-0036		TSTR: Si PNP 2N3906	04713	2N3906
A2R1	0698-4121	5	R: fxd prec comp 11.3 k Ω $\pm 1\%$ 1/8 W	75042	CEA T-O obd
A2R2	0757-0474	4	R: fxd prec met flm 243 k Ω $\pm 1\%$ 1/8 W	91637	MFF-1/8 T-O obd
A2R3	0686-3625	1	R: fxd comp 3.6 k Ω $\pm 5\%$ 1/2 W	01121	EB 3625
A2R4	0698-3178	2	R: fxd prec met flm 487 Ω $\pm 1\%$ 1/8 W	91637	MFF-1/8 T-O obd
A2R5	0698-4196	5	R: fxd prec met flm 1.07 k Ω $\pm 1\%$ 1/8 W	91637	MFF-1/8 T-O obd
A2R6	2100-0095	1	R: var comp flm 100 k Ω $\pm 30\%$ 0.10 W	71450	UPE 70RE (hp)
A2R7	0686-2265	1	R: fxd comp 22M $\pm 5\%$ 1/2 W	01121	EB-2265

Table 6-1 Replaceable Parts (Cont'd)

REFERENCE DESIGNATOR	-hp- PART NO.	TQ	DESCRIPTION	MFR	MFR PART NO
A2R8	0757-0410	1	R: fxd prec met flm 301 Ω $\pm 1\%$ 1/8 W	91637	MFF-1/8 T-O obd
A2R9	0757-0434	11	R: fxd prec met flm 3.65 k Ω $\pm 1\%$ 1/8 W	91637	MFF-1/8 T-O obd
A2R10	0698-3510	2	R: fxd prec met flm 453 Ω $\pm 1\%$ 1/8 W	91637	MFF-1/8 T-O obd
A2R11	0698-4457	1	R: fxd prec met flm 576 Ω $\pm 1\%$ 1/8 W	91637	MFF-1/8 T-O obd
A2R12	0757-0474		R: fxd met flm 243 k Ω $\pm 1\%$ 1/8 W	91637	MFF-1/8 T-O obd
A2R13	0757-0434		R: fxd prec met flm 3.65 k Ω $\pm 1\%$ 1/8 W	91637	MFF-1/8 T-O obd
A2R14	0698-4396	1	R: fxd prec met flm 80.6 Ω $\pm 1\%$ 1/8 W	91637	MFF-1/8 T-O obd
A2R15	0698-4121		R: fxd prec met flm 11.3 k Ω $\pm 1\%$ 1/8 W	75042	CEA T-O obd
A2R16	0757-0428	1	R: fxd prec met flm 1.62 k Ω $\pm 1\%$ 1/8 W	75042	CEA T-O obd
A2R17	0757-0808	1	R: fxd prec met flm 301 Ω $\pm 1\%$ 1/2 W	75042	CEC T-O obd
A2R18	0698-3557		R: fxd prec met flm 806 Ω $\pm 1\%$ 1/8 W	75042	CEA T-O obd
A2R19			Not assigned		
A2R20	0757-0794	2	R: fxd prec met flm 68.1 Ω $\pm 1\%$ 1/2 W	91637	MFF-1/2 T-O obd
A2R21	0698-4196		R: fxd prec met flm 1.07 k Ω $\pm 1\%$ 1/8 W	91637	MFF-1/8 T-O obd
A2R22, A2R23	0757-0434		R: fxd prec met flm 3.65 k Ω $\pm 1\%$ 1/8 W	91637	MFF-1/8 T-O obd
A2R24	0757-0290	2	R: fxd prec met flm 6.19 k Ω $\pm 1\%$ 1/8 W	91637	MFF-1/8 T-O obd
A2R25	0698-4121		R: fxd prec met flm 11.3 k Ω $\pm 1\%$ 1/8 W	75042	CEA T-O obd
A2R26	0757-0447	1	R: fxd prec met flm 16.2 k Ω $\pm 1\%$ 1/8 W	75042	CEA T-O obd
A2R27	0698-3155	1	R: fxd prec met flm 4.64 k Ω $\pm 1\%$ 1/8 W	91637	MFF-1/8 T-O obd
A2R28, A2R29	0757-0434		R: fxd prec met flm 3.65 k Ω $\pm 1\%$ 1/8 W	91637	MFF-1/8 T-O obd
A2R30	0698-3156	4	R: fxd prec met flm 14.7 k Ω $\pm 1\%$ 1/8 W	75042	CEA T-O obd
A2R31	0757-0794		R: fxd prec met flm 68.1 Ω $\pm 1\%$ 1/2 W	91637	MFF-1/2 T-O obd
A2R32	0698-4196		R: fxd prec met flm 1.07 k Ω $\pm 1\%$ 1/8 W	91637	MFF-1/8 T-O obd
A2R33	0757-0274		R: fxd prec met flm 1.21 k Ω $\pm 1\%$ 1/8 W	91637	MF-1/10-32
A2R34	0757-0408		R: fxd met flm 243 Ω $\pm 1\%$ 1/8 W	75042	CEA T-O obd
A2R35, A2R36	0757-0434		R: fxd prec met flm 3.65 k Ω $\pm 1\%$ 1/8 W	91637	MFF-1/8 T-O obd
A2R37	0757-0438	1	R: fxd prec met flm 5.11 k Ω $\pm 1\%$ 1/8 W	75042	CEA T-O obd
A2R38	0698-3156		R: fxd prec met flm 14.7 k Ω $\pm 1\%$ 1/8 W	75042	CEA T-O obd
A2R39	0757-0422		R: fxd prec met flm 909 Ω $\pm 1\%$ 1/8 W	91637	MF-1/10-32
A2R40	0698-4448	2	R: fxd prec met flm 294 Ω $\pm 1\%$ 1/8 W	19701	MF4C
A2R41	0698-4196		R: fxd prec met flm 1.07 k Ω $\pm 1\%$ 1/8 W	91637	MFF-1/8 T-O obd
A2R42	0757-0401		R: fxd prec met flm 100 Ω $\pm 1\%$ 1/8 W	75042	CEA T-O obd
A2R43	0757-0408	1	R: fxd prec met flm 243 Ω $\pm 1\%$ 1/8 W	75042	CEA T-O obd
A2R44	0698-3156		R: fxd prec met flm 14.7 k Ω $\pm 1\%$ 1/8 W	75042	CEA T-O obd
A2R45	0757-0277	2	R: fxd prec met flm 49.9 Ω $\pm 1\%$ 1/8 W	91637	MFF-1/2 T-2
A2R46	0757-0441	1	R: fxd prec met flm 8.25 k Ω $\pm 1\%$ 1/8 W	75042	CEA T-O obd
A2R47	0698-3157	2	R: fxd prec met flm 19.6 k Ω $\pm 1\%$ 1/8 W	75042	CEA T-O obd
A2R48	0757-0401		R: fxd prec met flm 100 Ω $\pm 1\%$ 1/8 W	75042	CEA T-O obd
A2R49	0698-3156		R: fxd prec met flm 14.7 k Ω $\pm 1\%$ 1/8 W	75042	CEA T-O obd
A2R50	0757-0434		R: fxd prec met flm 3.65 k Ω $\pm 1\%$ 1/8 W	91637	MFF-1/8 T-O obd
A2R51	0698-4121		R: fxd met flm 11.3 k Ω $\pm 1\%$ 1/8 W	75042	CEA T-O obd
A2R52	0757-0444	1	R: fxd prec met flm 12.1 k Ω $\pm 1\%$ 1/8 W	75042	CEA T-O obd
A2R53	0698-4121		R: fxd met flm 11.3 k Ω $\pm 1\%$ 1/8 W	75042	CEA T-O obd
A2R54	0757-0401		R: fxd prec met flm 100 Ω $\pm 1\%$ 1/8 W	75042	CEA T-O obd
A2R55	0698-3438		R: fxd prec met flm 147 Ω $\pm 1\%$ 1/8 W	91637	MFF-1/8 T-O obd
A2R56	0698-3450	2	R: fxd prec met flm 42.2 k Ω $\pm 1\%$ 1/8 W	91637	MFF-1/8 T-O obd
A2R57	0757-0408	1	R: fxd prec met flm 243 Ω $\pm 1\%$ 1/8 W	91637	MFF-1/8 T-O obd
A2R58, A2R59	2100-0290	3	R: var p ec ww 100 Ω $\pm 2\%$ 1-1/2 W	11237	110 obd
A2R60	0757-0277		R: fxd prec met flm 49.9 Ω $\pm 1\%$ 1/8 W	91637	MFF-1/8 T-O obd
A2R61	0698-3157		R: fxd prec met flm 19.6 k Ω $\pm 1\%$ 1/8 W	75042	CEA T-O obd
A2R62	2100-0290		R: var ww 100 Ω $\pm 2\%$ 1-1/2 W	11237	110 obd
A2R63	0698-4458	1	R: fxd flm 590 Ω $\pm 1\%$ 1/8 W	14674	C4 T-O obd
A2R64	0698-3434	1	R: fxd prec met flm 34.8 Ω $\pm 1\%$ 1/8 W	75042	CEA T-O obd
A2R65	0757-0381	1	R: fxd prec met flm 15 Ω $\pm 1\%$ 1/8 W	91637	MFF-1/8 T-O obd
A2R66	0757-0384	1	R: fxd prec met flm 20 Ω $\pm 1\%$ 1/8 W	91637	MFF-1/8 T-O obd

Table 6-1. Replaceable Parts (Cont'd)

REFERENCE DESIGNATOR	-hp- PART NO	TQ	DESCRIPTION	MFR	MFR PART NO
A2R67	0757-0346	1	R: fxd prec met flm 10 Ω $\pm 1\%$ 1/8 W	91637	MFF-1/8 T-O obd
A2R68	2100-0277		R: var comp flm 100 Ω $\pm 2\%$ 0.3 W	71450	Type UPE65 CV
A2R69	0693-4196		R: fxd prec met flm 1.07 k Ω $\pm 1\%$ 1/8 W	91637	MFF-1/8 T-O obd
A2R70	0698-3450		R: fxd prec met flm 42.2 k Ω $\pm 1\%$ 1/8 W	91637	MFF-1/8 T-O obd
A2R71	0757-0290		R: fxd prec met flm 6.19 k Ω $\pm 1\%$ 1/8 W	91637	MFF-1/8 T-O obd
A2R72	0698-3178	2	R: fxd prec met flm 487 Ω $\pm 1\%$ 1/8 W	91637	MFF-1/8 T-O obd
A2R73	0757-0474		R: fxd prec met flm 243 k Ω $\pm 1\%$ 1/8 W	91637	MFF-1/8 T-O obd
A2R74, A2R75	0757-0434		R: fxd prec met flm 3.65 k Ω $\pm 1\%$ 1/8 W (400FL only, A2R75)	91637	MFF-1/8 T-O obd
C1	0180-0106		C: fxd Ta 60 μ F $\pm 20\%$ 6 vdcw (400FL only)	56289	150D606X006B2
CR1	1901-0040		Diode: Si (400F only) 30 mA at ± 10 pV .12 μ F 2 ns	07910	CD6319 obd
DS1	1450-0049	2	Lamp: NF-2E clear	72765	599-125 obd
F1	2110-0320	1	Fuse: 150 MAT SB	71400	MDL 15/100
J1 through J3 J4	1251-2357	1	See MP3, MP4, MP12, and MP13 Connector: ac power cord receptacle	87930	H-1061-2
L1, L2	9140-0041	2	Inductor: fxd 2.5 mH $\pm 10\%$	95265	SA-2500-I
M1	1120-0018	1	Meter: linear (400F only)	-hp-	
M1	1120-0919	1	Meter: log (400FL only)	-hp-	
M1	1120-1273	1	Meter: linear (400F only, Option 01)	-hp-	
MP1	0340-0090	1	Insulator: 2 hole BP with locating key	-hp-	
MP2	0340-0086	1	Insulator: 2 hole without locating key	-hp-	
MP3	1510-0010	3	Binding Post Ass'y: red battery voltage	-hp-	
MP4	1510-0011	2	Binding Post Ass'y: black rear panel	-hp-	
MP5	1400-0084	1	Holder: fuse	75915	342014
MP6	0340-0087	1	Insulator: 3 hole BP in line	-hp-	
MP7	0340-0091	1	Insulator: 3 hole BP with locating key	-hp-	
MP8	1205-0033	2	Semiconductor: heat dissipator	05820	NF-207
MP9	00400-00605	1	Shield: meter	-hp-	
MP10	0370-0113	1	Knob: bar with one arrow part of S1 black	-hp-	
MP11	0370-0115	1	Knob: bar red with pointer part of S2	-hp-	
MP12	1510-0035	1	Binding Post Ass'y: black INPUT	-hp-	
MP13	1510-0036	1	Binding Post Ass'y: red INPUT	-hp-	
MP14	0340-0099	2	Insulator: binding post (single)	-hp-	
MP15	0340-0100	1	Insulator: binding post (single)	-hp-	
MP16	5040-4503	6	Insulator: nylon threaded	-hp-	
MP17	00400-05502	1	Can: shield	-hp-	
MP18	00400-04102	1	Cover: attenuator	-hp-	
MP19	1440-0050	2	Plate: handle plated steel	12136	obd
MP20	1440-0048	1	Strap: handle, black vinyl	12136	obd
MP21	1440-0049	2	Cap: handle, brushed cadmium	12136	obd
MP22	00400-64103	1	Cover Ass'y: top 5 x 11 sm	-hp-	
MP23	5060-0703	2	Frame: sub mod 6 x 11	-hp-	
MP24	00400-00210	1	Panel: rear (order 00400-66202 to include power connector and switch.)	-hp-	
MP25	5000-8565	2	Cover Ass'y: side 6 x 11 sm	-hp-	
MP26	5000-8571	1	Cover Ass'y: bottom 5 x 11 sm	-hp-	
MP27	1490-0031	1	Stand: 1/3 mod tilt	91260	obd
MP28	5060-0727	1	Foot Ass'y: 1/3 mod	-hp-	
MP29	5040-0700	1	Hinge	-hp-	
MP30	00400-00227	1	Panel: front (400FL only)	-hp-	
	00400-00225	1	Panel: front (400F only)	-hp-	
MP31	5020-6852	1	Trim: meter third mod (All Models)	-hp-	
MP32	5000-5838	2	Bracket: cover retainer	-hp-	
MP33	0590-0052	5	Nut: Tinnerman	78553	C-8020-632-24B

Table 6-1. Replaceable Parts (Cont'd)

REFERENCE DESIGNATOR	-hp- PART NO.	TQ	DESCRIPTION	MFR	MFR PART NO
R1	0687-3331	1	R: fxd comp 33 k Ω \pm 10% 1/2 W	01121	EB-3331
S1	00400-61903	1	Switch Assembly: range includes C1 CR1, CR2 R1 through R15	-hp-	
S1C1 S1CR1, S1CR2	0160-0207 1901-0040	1	C: fxd mylar 0.01 μ F \pm 5% 200 V Diode: S1 30 mA at +10 V piv 12 pF 2 ns	56289 07910	192P10352 CD6319 otd
S1R1 S1R2 through S1R6	0757-6167 0693-4118	1 5	R: fxd prec met flm 143 Ω \pm 1% 1/4 W R: fxd prec met flm 277.48 Ω \pm 0.1% 1/4 W	19701 75042	MF6C T-O otd CEB T-3 otd
S1R7 through S1R12	0698-4119	6	R: fxd prec met flm 410.26 Ω \pm 0.1% 1/4 W	75042	CEB T-3 otd
S1R13 S1R14, S1R15	0698-4117 0687-1501	1 2	R: fxd prec met flm 189.72 Ω \pm 0.1% 1/4 W R: fxd comp 15 Ω \pm 10% 1/2 W	75042 -hp-	CEB T-3 otd
S2 S3	3101-0036	1	P/o RANGE switch assembly S1 Switch: toggle SPST On-None-Off 3 amps 25 V	88140	8928K61
S4	3101-1234	1	Switch: slide DPDT	82389	11A-1242A otd
T1	9100-1321	1	Transformer	-hp-	
TP1 through TP4	0360-0435	4	Terminal: board silver plated brass	12284	1012-3
W1 W2	00400-61602 00400-61603	1 1	Cable 1: power Cable 2: meter	-hp- -hp-	
	8120-1348	1	Cord: power	70903	otd

SECTION VII TROUBLESHOOTING AND CIRCUIT DIAGRAMS

7-1. INTRODUCTION.

7-2. This section contains the schematic and component location diagrams for the Model 400F/FL. Figure 7-1 shows a flattened view of the RANGE switch and part of the internal wiring data. Figure 7-2 shows the component

location on the A1 and A2 printed circuit boards and the location of the internal adjustments. Figure 7-3 is the schematic diagram of the 400F/FL. Main signal paths and feedback paths are identified. (Refer to GENERAL SCHEMATIC NOTES.)

REFERENCE DESIGNATIONS

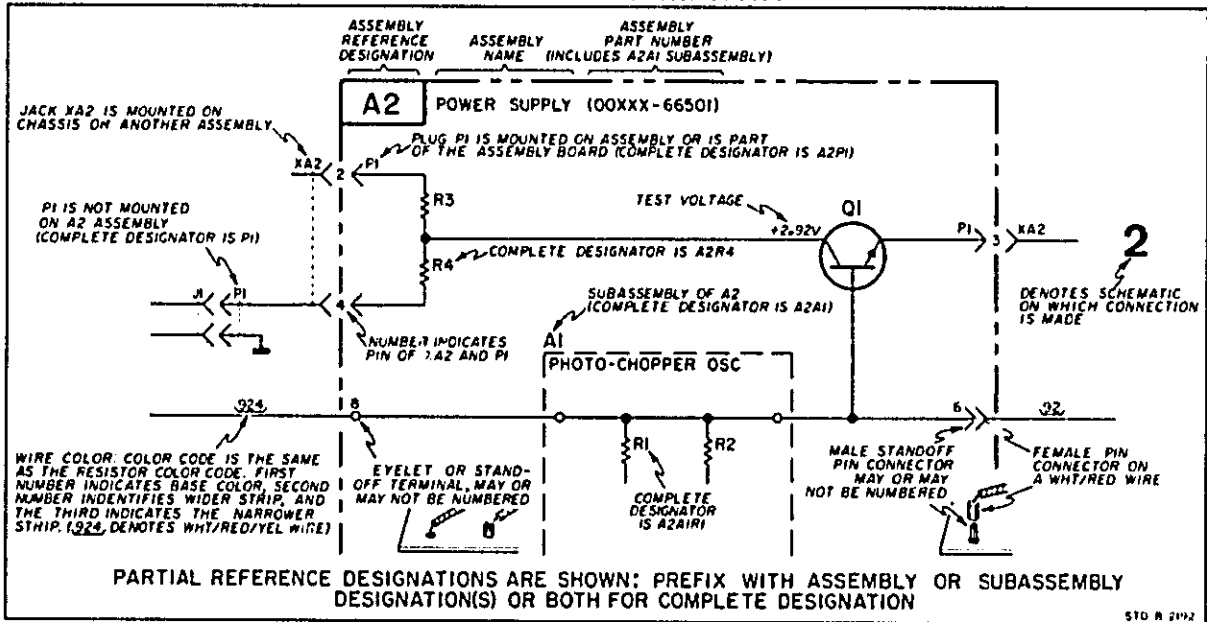

GENERAL SCHEMATIC NOTES

- | | |
|--|--|
| <ol style="list-style-type: none"> 1. PARTIAL REFERENCE DESIGNATIONS ARE SHOWN: PREFIX WITH ASSEMBLY OR SUBASSEMBLY DESIGNATION(S) OR BOTH FOR COMPLETE DESIGNATION. 2. COMPONENT VALUES ARE SHOWN AS FOLLOWS UNLESS OTHERWISE NOTED: <ul style="list-style-type: none"> (a) RESISTANCE IN OHMS (b) CAPACITANCE IN MICROFARADS (c) INDUCTANCE IN MILLIHENRIES 3. DENOTES ASSEMBLY (RED) 4. DENOTES SHIELD. 5. DENOTES MAIN SIGNAL PATH. 6. DENOTES FEEDBACK PATH 7. DENOTES FRONT PANEL MARKING. | <ol style="list-style-type: none"> 8. DENOTES REAR PANEL MARKING. 9. DENOTES SCREWDRIVER ADJUST. 10. 918 DENOTES WIRE COLOR USING STANDARD COLOR CODE. (e.g. 918 = WHITE, BROWN, GRAY) 11. * OPTIMUM VALUE SELECTED AT FACTORY. 12. DENOTES WIRE CONNECTION. 13. DENOTES POWER GROUND. 14. DENOTES FLOATING CHASSIS GROUND. 15. DENOTES BOARD GROUND. 16. DENOTES CONNECTION TO POWER GROUND. |
|--|--|

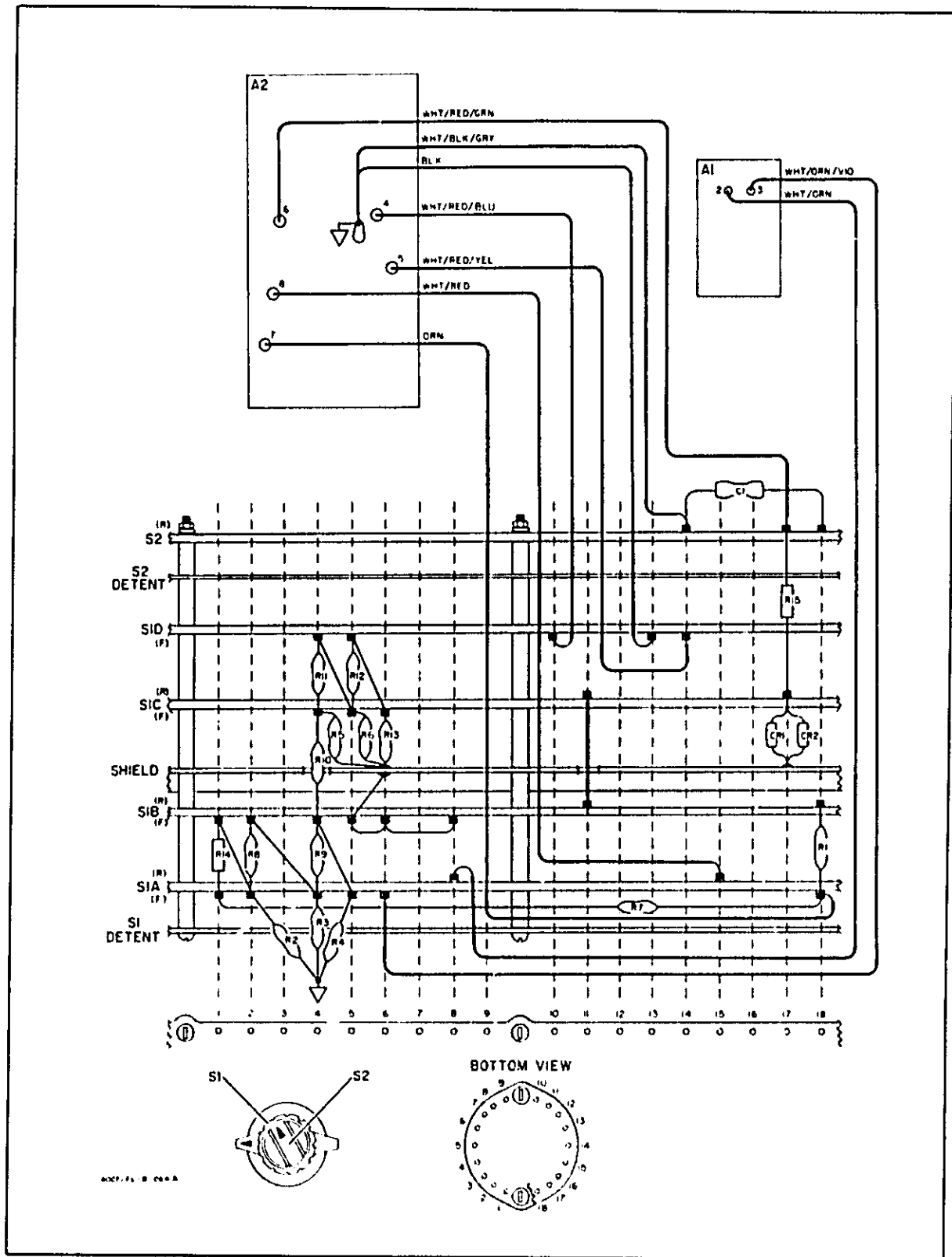
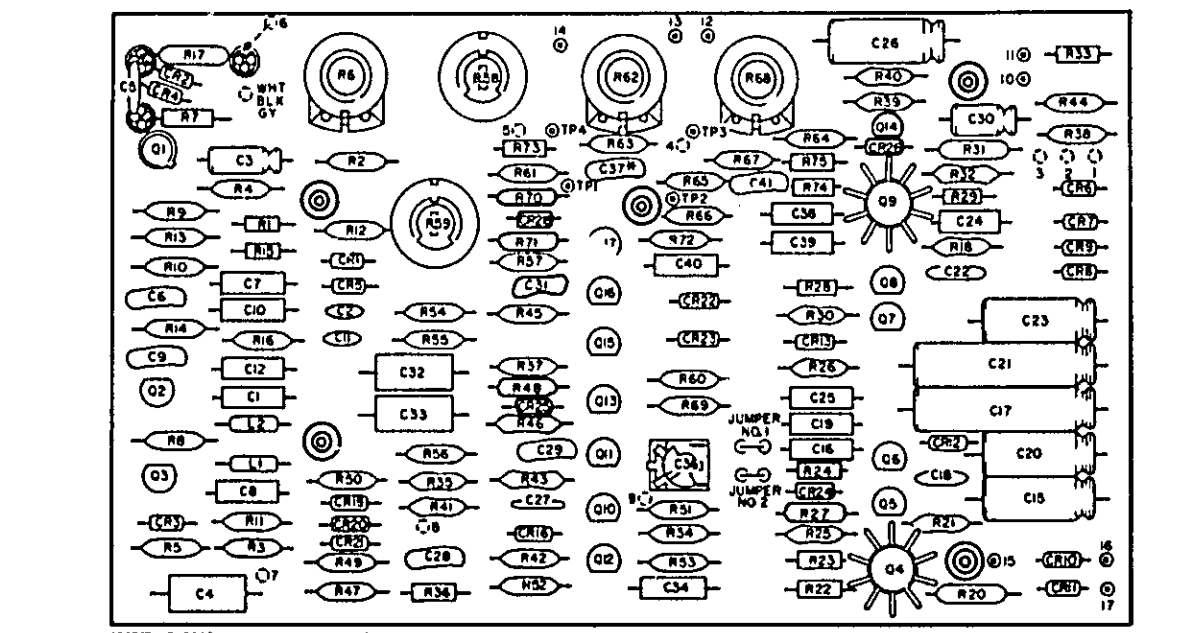
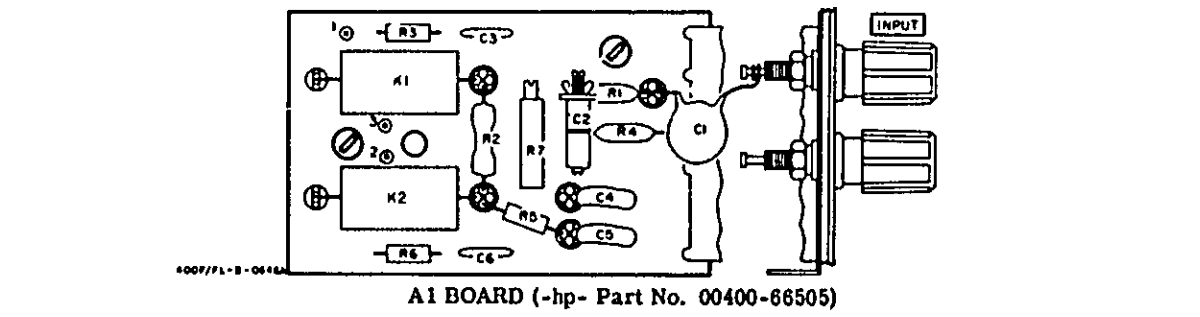

Figure 7-1. Model 400F/FL Range Switch and p/o Internal Wiring Data.



A2 BOARD (-hp- Part No. 00400-66504)



A1 BOARD (-hp- Part No. 00400-66505)

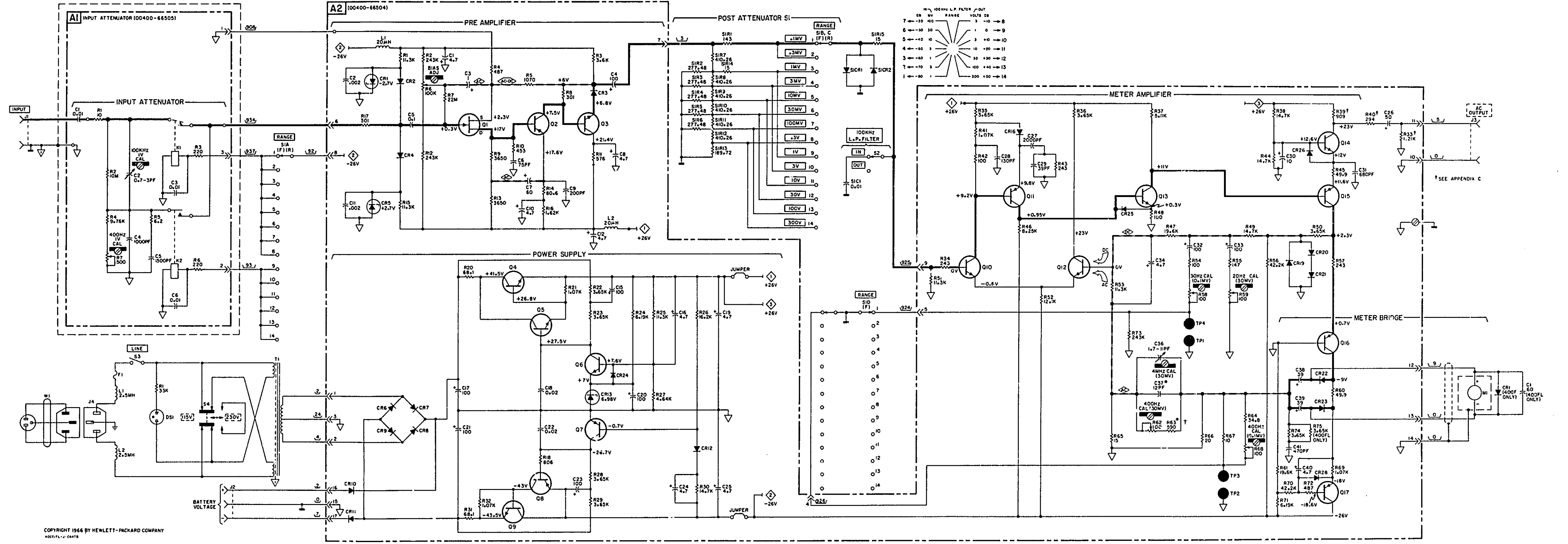
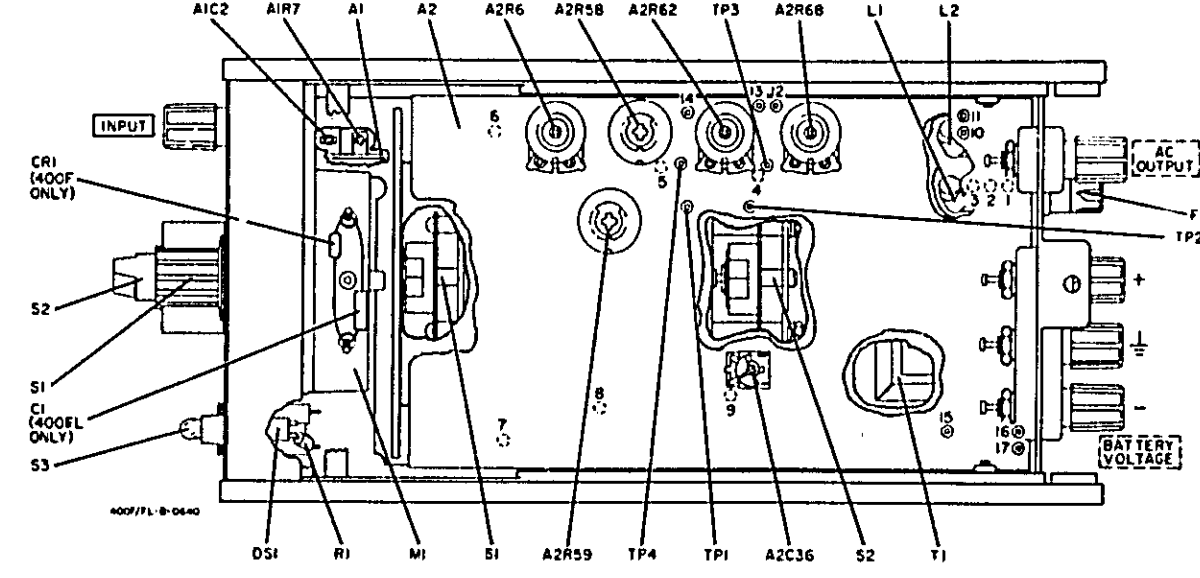

COPYRIGHT 1966 BY HEWLETT-PACKARD COMPANY
400F/FL-1-C4878

Figure 7-2. Model 400F/FL Schematic Diagram.
7-3/7-4

CODE LIST OF MANUFACTURERS

The following code numbers are from the Federal Supply Code for Manufacturers Cataloging Handbooks H4-1 (Name to Code) and H4-2 (Code to Name) and their latest supplements. The date of revision and the date of the supplements used appear at the bottom of each page. Alpha betrical codes have been arbitrarily assigned to suppliers not appearing in the H4 Handbooks.

Code No	Manufacturer	Address	Code No	Manufacturer	Address	Code No	Manufacturer	Address
00000	U. S. A. Common	Any supplier of U. S.	05347	Ultronix, Inc.	San Mateo, Cal	11236	CTS of Berne, Inc.	Berne, Ind
00136	McCoy Electronics	Mount Holly Springs, Pa	05397	Union Carbide Corp., Elect		11237	Chicago Telephone of	
00213	Sage Electronics Corp.	Rochester, N. Y.		Div.	New York, N. Y.		California, Inc.	No. Pasadena, Cal
00287	Cemco, Inc.	Danielson, Conn	05574	Viking Ind. Inc.	Canoga Park, Cal	11242	Day State Electronics Corp.	Waltham, Mass
00334	Humidial	Colton, Calif	05593	Icone Electro-Plastics Inc.	Sunnyvale, Cal	11312	Telebyn Inc. - Microwave	
00348	Micron, Co., Inc.	Valley Stream, N. Y.	05616	Coamo Plastic (non Electrical			Div.	Palo Alto, Cal
00373	Garlock Inc.	Cherry Hill, N. J.		Spec Co.)	Cleveland, Ohio	11314	NAMBIT Seal	Downey, Cal
00656	Aerovox Corp.	New Bedford, Mass.	05624	Barber Optical Co.	Rockford, Ill	11453	Precision Connector Corp.	Jamaica, N. Y.
00779	Amp. Inc.	Harrisburg, Pa	05728	Tiffen Optical Co.		11534	Duncan Electronics Inc.	Costa Mesa, Cal
00781	Aircraft Radio Corp.	Bounton, N. J.		Roslyn Heights,	Long Island, N. Y.	11711	General Instrument Corp.	
00809	Crown, Ltd.	Whitby, Ontario, Canada	05729	Metro-Tel Corp.	Westbury, N. Y.		Semiconductor Division Products	
00815	Northern Engineering		05783	Stewart Engineering Co.	Santa Cruz, Cal		Group	Newark, N. J.
	Laboratories, Inc.		05820	Wakefield Engineering Inc.	Wakefield, Mass	11717	Imperial Electronics, Inc.	Buena Park, Cal
00853	Sangamo Electric Co.	Burlington, Wis	06004	Hansch Co., Div. of Stewart		11870	Melaba, Inc.	Palo Alto, Cal
	Pickens Div.	Pickens, S. C.		Warner Corp.	Bridgeport, Conn	12136	Philadelphia Handle Co.	Camden, N. J.
00866	Goe Engineering Co.	City of Industry, Cal.	06090	Raychem Corp.	Redwood City, Cal	12361	Grove Mfg. Co., Inc.	Shad Grove, Pa.
00891	Carl E. Holmes Corp.	Los Angeles, Cal.	06175	Bausch and Lomb Optical		12574	Galton Ind. Inc. - Data System	
00829	Microlab Inc.	Livingston, N. J.		Co.	Rochester, N. Y.		Div.	Albuquerque, N. M.
01002	General Electric Co.,		06402	E. T. A. Products Co. of	Chicago, Ill	12697	Clarostat Mfg. Co.	Dover, N. H.
	Capacitor Dept.	Hudson Falls, N. Y.		America		12728	Elmar Filter Corp.	W. Haven, Conn
01009	Alden Products Co.	Brockton, Mass.	06540	Amalton Electronic Hardware	New Rochelle, N. Y.	12859	Nippon Electric Co., Ltd.	Tokyo, Japan
01121	Allen Bradley Co.	Milwaukee, Wis		Co., Inc.		12881	Metex Electronics Corp.	Clark, N. J.
01255	Liton Industries, Inc.	Beverly Hills, Cal.	06555	Reede Electrical Instrument		12930	Delta Semiconductor Inc.	Newport Beach, Cal
01281	TRW Semiconductors, Inc.	Lawndale, Cal		Co., Inc.	Penacook, N. H.	12954	Dickson Electronics Corp.	Scottsdale, Arizona
01295	Texas Instruments, Inc.		06666	General Devices Co., Inc.	Indianapolis, Ind	13019	Aero Supply Co., Inc.	Wichita, Kansas
	Transistor Products Div.	Dallas, Texas	06751	Components Inc., Ariz. Div.	Phoenix, Arizona	13061	Wilco Products	Detroit, Mich
01349	The Alliance Mfg. Co.	Alliance, Ohio	06812	Torrington Mfg. Co., West Div.	Van Nuys, Cal	13103	Thermulloy	Dallas, Texas
01538	Small Parts Inc.	Los Angeles, Cal.	06880	Varian Assoc. - Etmar Div.	San Carlos, Cal	13327	Soliton Devices Inc.	Tappan, N. Y.
01589	Pacific Relays, Inc.	Van Nuys, Cal.	07068	Keivin Electric Co.	Van Nuys, Cal	13396	Telefunken (GmbH)	Hanover, Germany
01670	Gudebrod Bros. Silk Co.	New York, N. Y.	07124	Digitran Co.	Pasadena, Cal	13835	Mulland-Wright Div. of	
01930	Amerock Corp.	Rockford, Ill.	07137	Transistor Electronics	Minneapolis, Minn		Pacific Industries, Inc.	Kansas City, Kansas
01960	Pulse Engineering Co.	Santa Clara, Cal		Corp.		14099	Sem-Tech	Newbury Park, Cal
02114	Ferroxcube Corp. of	America	07138	Westinghouse Electric	Elmira, N. Y.	14193	Calh. Resistor Corp.	Santa Monica, Cal
	America	Saugerties, N. Y.		Corp. - Electronic Tube Div.		14298	American Components, Inc.	Conshohocken, Pa.
02116	Wheelock Signals, Inc.	Long Branch, N. J.	07149	Filmohm Corp.	New York, N. Y.	14433	ITT Semiconductor, a Div. of	
02266	Cole Rubber and Plastics Inc.	Sunnyvale, Cal.	07233	Cinch-Graphix Co.	City of Industry, Cal		Int. Telephone and Telegraph	
02660	Amphenol-Burg Electronics	Broadview, Ill.	07256	Silicon Transistor Corp.	Carle Place, N. Y.		Corporation	West Palm Beach, Fla.
	Corp.		07261	Avnet Corp.	Culver City, Cal	14493	Hewlett-Packard Company	Loveland, Colo
02735	Radio Corp. of America, Semi-		07263	Fairchild Camera & Inst		14655	Cornell Dublier Electric Corp.	Newark, N. J.
	conductor and Materials			Semiconductor Div.	Mountain View, Cal	14674	Corning Glass Works	Corning, N. Y.
	Division	Somerville, N. J.	07322	Minnesota Rubber Co.	Minneapolis, Minn	14732	Electro-Cube Inc.	San Gabriel, Cal
02771	Vorcline Co. of America, Inc.	Old Saybrook, Conn	07387	Bircher Corp. The	Monterey Park, Cal	14960	Williams Mfg. Co.	San Jose, Cal
			07397	Sylvania Elect. Prod. Inc.		15106	The Sphere Co., Inc.	Little Falls, N. J.
02777	Hopkins Engineering Co.	San Fernando, Cal	07700	Mt. View Operations	Mountain View, Cal	15203	Webster Electronics Co.	New York, N. Y.
02875	Hudson Tool & Die	Newark, N. J.		Technical Wire Products		15287	Scientex Corp.	Northridge, Cal
03296	Nylon Molding Corp.	Springfield, N. J.	07829	Bodine Elect. Co.	Cranford, N. J.	15291	Adjustable Hushing Co.	N. Hollywood, Cal
03508	G. E. Semiconductor Prod.	Syracuse, N. Y.	07910	Continental Device Corp.	Chicago, Ill	15558	Micron Electronics - Garden	City, Long Island, N. Y.
	Dept.		07933	Raytheon Mfg. Co., Semi-	Hawthorne, Cal	15566	Amprobe Inst. Corp.	Lyndbrook, N. Y.
03705	Apex Machine & Tool Co.	Dayton, Ohio	07980	conductor Div.	Mountain View, Cal	15631	Cabletronics	Costa Mesa, Cal
03797	Eldema Corp.	Compton, Calif		Hewlett-Packard Co.,		15772	Twentieth Century Coil	
03818	Parker Seal Co.	Los Angeles, Cal		New Jersey Division	Rockaway, N. J.	15801	Prival Elev. Int.	Santa Clara, Cal
03877	Transitron Electric Corp.	Wakefield, Mass.	08145	U. S. Engineering Co.	Los Angeles, Cal	15818	Ampico Inc.	Frammingham, Mass
03888	Pyrofilm Resistor Co.,		08289	Blinn, Delbert Co.	Pomona, Cal	16037	Spruce Pine Mica Co.	Mountain View, Cal
	Inc.	Cedar Knolls, N. J.	08358	Burgess Battery Co.		16179	Omni Spectra Inc.	Spruce Pine, N. C.
03954	Singer Co., Die Mfg. Div.			Niagara Falls, Ontario, Canada		16352	Computer Diode Corp.	Detroit, Ill
	Finderne Plant	Somerville, N. J.	08524	Deutch Fastener Corp.	Los Angeles, Cal	16554	Electrod Co.	Union, N. J.
04009	Arrow, Hart and Hegeman	Hartford, Conn.	08664	Bristol Co., The	Waterbury, Conn	16585	Bonds Aircraft Nut Corp.	Pasadena, Cal
	Elect. Co.		08717	Sloan Company	San Valley, Cal.	16688	The Fur Meter Div.	Brooklyn, N. Y.
04013	Tarus Corp.	Lambertville, N. J.	08718	ITT Cannon Electric Inc.	Phoenix, Arizona	16758	Delco Radio Div. of G. M. Corp.	K. Kama, Ind
04062	Arco Electronic Inc.	Great Neck, N. Y.	08727	National Radio Lab. Inc.	Paramus, N. J.	17109	Thermometrics Inc.	Canoga Park, Cal
04217	Essex Wire	Los Angeles, Cal	08792	CBS Electronics Semiconductor		17474	Tranco Company	Mountain View, Cal
04222	Hi-Q Division of Aerovox	Myrtle Beach, S. C.		Operations, Div. of CBS Inc.	Lowell, Mass.	17575	Hamlin Metal Products Corp.	Akron, Ohio
04354	Precision Paper Tube Co.	Wheeling, Ill.	08806	General Electric Co.		17745	Angstrom Prec. Inc.	No. Hollywood, Cal
04404	Palo Alto Division of Hewlett-			Miniature Lamp Dept.	Cleveland, Ohio	17856	Siliconix Inc.	Sunnyvale, Cal
	Packard Co.	Palo Alto, Cal	08884	Mel-Rain	Indianapolis, Ind	17870	McGrath-Edison Co.	Manchester, N. H.
04651	Sylvania Electric Products,	Mountain View, Cal	09026	Babcock Relays Div.	Costa Mesa, Cal	18042	Power Design Pacific Inc.	Palo Alto, Cal
	Microwave Device Div.		09037	Electronic Enclosures Inc.	Los Angeles, Calif	18083	Clevite Corp. Semiconductor Div.	Palo Alto, Cal
04673	Dakota Engr. Inc.	Culver City, Cal	09134	Texas Capacitor Co.	Houston, Texas	18324	Sigmatix Corp.	Sunnyvale, Cal
04713	Motorola Inc. Semiconductor	Phoenix, Arizona	09145	Tech Ind. Inc. Atohm		18476	Fy-Car Mfg. Co., Inc.	Holliston, Mass
	Prod. Div.			Elect.	Burbank, Cal	18486	TRW Elect. Comp. Div.	Des Plaines, Ill
04732	Filtzon Co., Inc. Western	Culver City, Cal.	09250	Electro Assemblies, Inc.	Chicago, Ill	18565	Chomeros	Plainville, Mass
	Div.		09333	U. & K. Components Inc.	Newton, Mass	18583	Curbs Instrument, Inc.	Mt. Kisco, N. Y.
04773	Automatic Electric Co.	Northlake, Ill	09569	Mallory Battery Co. of		18873	F. T. DuPont and Co., Inc.	Wilmington, Del
04796	Squonia Wire Co.	Redwood City, Cal		Canada, Ltd.	Toronto, Ontario, Canada	18911	Durant Mfg. Co.	Milwaukee, Wis
04811	Precision Coil Spring Co.	El Monte, Cal	09795	Pennsylvania Fluorocarbon	Clifton Heights, Penn.	19315	The Bendix Corp. - Navigation &	
04870	P. M. Motor Company	Westchester, Ill	09922	Burnly Corp.	Norwalk, Conn.		Control Div.	Teterboro, N. J.
04919	Component Mfg. Service	W. Bridgewater, Mass	10214	General Transistor Western	Los Angeles, Cal	19560	Thomas A. Edison Industries,	
	Co.			Corp.			Div. of McGraw-Hill	West Orange, N. J.
05006	Twentieth Century Plastics,	Los Angeles, Cal	10431	Ty-Tal, Inc.	Berkeley, Cal	19589	Concoa	Baldwin Park, Cal
	Inc.		10446	Carborandum Co.	Niagara Falls, N. Y.			

00015-49
Revised: May, 1970

From Handbooks & Supplements
H4-1 Dated January 1970

CODE LIST OF MANUFACTURERS (Continued)

Code No.	Manufacturer	Address	Code No.	Manufacturer	Address	Code No.	Manufacturer	Address
19644	LHC Electronics	Burnshead, N.Y.	71482	C. P. Clark & Co.	Chicago, Ill.	78452	Thompson Dramer & Co.	Chicago, Ill.
19701	Electra Mig. Co.	Independence, Kansas	71500	Centralab Div. of Globe Union Inc.	Milwaukee, Wis.	78471	Tilley Mig. Co.	San Francisco, Cal.
20183	General Altronics Corp.	Philadelphia, Pa.	71511	Commercial Plastics Co.	Chicago, Ill.	78486	Stackpole Carbon Co.	St. Marys, Pa.
21226	Especone, Inc.	Long Island City, N.Y.	71512	Cornish Wire Co., The	New York, N.Y.	78493	Standard Thompson Corp.	Waltham, Mass.
21355	Fairair Bearing Co., The	New Britain, Conn.	71700	Coto Coal Co., Inc.	Providence, R.I.	78553	Tinnerman Products, Inc.	Cleveland, Ohio
21520	Fansteel Metallurgical Corp.	N. Chicago, Ill.	71707	Chicago Miniature Lamp Works	Chicago, Ill.	78790	Transformer Engineers	San Gabriel, Cal.
22020	General Reed Co.	Menchen, N.J.	71744	Cinch Mig. Co.	Chicago, Ill.	78947	Unite Co.	Newtownville, Mass.
22642	Tekscan Corp.	Indianapolis, Ind.	71785	Howard B. Jones Div.	Chicago, Ill.	79136	Walter Kohmser Inc.	Long Island City, N.Y.
2376	British Radio Electronics Ltd.	Washington, D.C.	71984	Des Corning Corp.	Midland, Mich.	79142	Yocum Heat, Inc.	Hartford, Conn.
24455	G. E. Lamp Division, Nela Park	Cleveland, Ohio	72136	Electro Motive Mig. Co., Inc.	Willimantic, Conn.	79251	Wenig Mig. Co.	Chicago, Ill.
24655	General Radio Co.	West Concord, Mass.	72619	Dualight Corp.	Brooklyn, N.Y.	79727	Continental West Electronics Corp.	Philadelphia, Pa.
24681	Memcor Inc., Comp. Div.	Huntington, Ind.	72656	Indiana General Corp. Electronics Div.	Kearny, N.J.	79963	Zorrick Mig. Corp.	New Rochelle, N.Y.
26365	Gries Reproducer Corp.	New Rochelle, N.Y.	72699	General Instrument Corp., Cap. Division	Newark, N.J.	80031	Mepro Division of Sessions Clock Co.	Morrisstown, N.J.
26462	Grobert File Co. of America, Inc.	Carlstadt, N.J.	72765	Drake Mig. Co.	Harwood Heights, Ill.	80033	Prosthe Corp.	Toledo, Ohio
26651	Compac Hollister Co.	Hollister, Cal.	72825	Hugh H. Eby Inc.	Philadelphia, Pa.	80120	Schultz Alloy Products Co.	Elizabeth, N.J.
26992	Hamilton Watch Co.	Lancaster, Pa.	72928	Guleman Co.	Chicago, Ill.	80131	Electronic Industries Association	Standard tube or semi-conductor device, any manufacturer
28480	Hewlett-Packard Co.	Palo Alto, Cal.	72962	Elastic Stop Nut Corp.	Union, N.J.	80207	Conman Swit. Div. Mason Electronics Corp.	Wallingford, Conn.
28520	Heyman Mig. Co.	Kenilworth, N.J.	72964	Robert M. Hadley Co.	Los Angeles, Cal.	80223	United Transformer Corp.	New York, N.Y.
30817	Instrument Specialties Co., Inc.	Little Falls, N.J.	72982	Eric Technological Products, Inc.	Erie, Pa.	80248	Oxford Electric Corp.	Chicago, Ill.
33173	G. E. Receiving Tube Dept	Owensboro, Ky.	73061	Hansen Mig. Co., Inc.	Princeton, Ind.	80294	Bourne Inc.	Riverside, Cal.
35434	Electron Inc.	Chicago, Ill.	73138	Helipot Div. of Beckman Inst., Inc.	Fullerton, Cal.	80411	Arco Div. of Robertshaw Controls Co.	Columbus, Ohio
36196	Stanwyrk Coil Products, Ltd.	Hawkesbury, Ontario, Canada	73293	Hughes Products Division of Hughes Aircraft Co.	Newport Beach, Cal.	80486	All Star Products Inc.	Indian, Ohio
36287	Cunningham, W. H. & Hill, Ltd.	Toronto, Ontario, Canada	73445	Ampere's Elect. Co.	Hicksville, L.I., N.Y.	80509	Avery Label Co.	Monrovia, Cal.
37942	P. R. Mallory & Co., Inc.	Indianapolis, Ind.	73506	Bradley Semiconductor Corp.	New Haven, Conn.	80583	Hammurby & Co., Inc.	Mary Hill, N.C.
39543	Mechanical Industries Prod. Co.	Akron, Ohio	73559	Carling Electric, Inc.	Hartford, Conn.	80640	Stevens Arnold Co., Inc.	Boston, Mass.
40920	Miniature Precision Bearings, Inc.	Keene, N.H.	73586	Circle F Mig. Co.	Trenton, N.J.	80813	Dimito Gray Co.	Dayton, Ohio
40931	Honeywell Inc.	Minneapolis, Minn.	73682	George K. Garrett Co.	Philadelphia, Pa.	81020	International Inst. Inc.	Orange, Conn.
42100	Muter Co.	Chicago, Ill.	73734	Federal Screw Products, Inc.	Chicago, Ill.	81073	Grasshill Co.	LaGrange, Ill.
43990	C. A. Norgren Co.	Englewood, Colo.	73743	Fischer Special Mig. Co.	Cincinnati, Ohio	81095	Tread Transformer Corp.	Venture, Cal.
44655	Ohmite Mig. Co.	Shokie, Ill.	73793	General Industries Co., The	Elyria, Ohio	81212	Winchester Elec. Div. Tifton Ind., Inc.	Oakville, Conn.
46384	Penn. Eng. & Mig. Corp.	Dyersburg, Pa.	73846	Goshen Stamping & Tool Co.	Goshen, Ind.	81349	Military Specification	
47804	Polaroid Corp.	Cambridge, Mass.	73899	JFD Electronics Corp.	Brooklyn, N.Y.	81483	International Rectifier Corp.	Ft. Snodgrass, Cal.
48620	Precision Thermometer & Inst. Co.	Southampton, Pa.	73905	Jennings Radio Mig. Corp.	San Jose, Cal.	81541	Airgas Electronics, Inc.	Cambridge, Maryland
49956	Microwave & Power Tube Div.	Waltham, Mass.	73957	Grisow - Pin Corp.	Ridgely, N.J.	81600	Barry Controls, Div. Barry Wright Corp.	Watertown, Mass.
52090	Rowan Controller Co.	Westminster, Md.	74276	Signalite Inc.	Septon, N.J.	82042	Carter Precision Electric Co.	Shokie, Ill.
52983	HP Co., Med. Elec. Div.	Waltham, Mass.	74455	J. H. Winn, and Sons	Winchester, Mass.	82047	Sparta Faraday Inc. Copper Hewitt Electric Div.	Hoboken, N.J.
54294	Shalleross Mig. Co.	Selma, N.C.	74461	Industrial Condenser Corp.	Chicago, Ill.	82116	Electric Regulator Corp.	Norwalk, Conn.
55026	Simpson Electric Co.	Chicago, Ill.	74868	H. F. Products Division of Ampco-Borg Electronic Corp.	Danbury, Conn.	82142	Deffers Electronics Division of Speer Carbon Co.	Do Bois, Pa.
55933	Sinotone Corp.	Firmford, N.Y.	74970	E. F. Johnson Co.	Wadena, Minn.	82170	Fairchild Camera & Inst. Corp.	
56137	Spaulding Fibre Co., Inc.	No. Norwalk, Conn.	75042	International Resistance Co.	Philadelphia, Pa.	82209	Space & Defense Systems Div. Maguire Industries, Inc.	Paramus, N.J.
56289	Sprague Electric Co.	North Adams, Mass.	75263	Keystone Carbon Co., Inc.	St. Marys, Pa.	82219	Sylvania Electric Prod. Inc. Electronic Tube Division	Emporium, Pa.
58474	Superior Elect. Co.	Bristol, Conn.	75378	CFS Knights, Inc.	Sandwich, Ill.	82376	Astron Corp.	East Newark, N.J.
59446	Telyx Corp.	Tulsa, Okla.	75382	Kulka Electric Corp.	Mt. Vernon, N.Y.	82399	Sathbraff Inc.	Chicago, Ill.
59730	Thomas & Betts Co.	Elizabeth, N.J.	75818	Lenz Electric Mig. Co.	Chicago, Ill.	82847	Metals & Controls Inc. Spencer Products	Attleboro, Mass.
60741	Triplett Electrical Inst. Co.	Bluffton, Ohio	75915	Littelfuse, Inc.	Des Plaines, Ill.	82768	Phillips Advance Control Co.	Joliet, Ill.
61775	Union Switch and Signal Div. of Westinghouse Air Brake Co.	Pittsburgh, Pa.	76005	Lord Mig. Co.	Erie, Pa.	82906	Research Products Corp.	Madison, Wis.
62110	Universal Electric Co.	Oakman, Mich.	76210	C. W. Marwede	San Francisco, Cal.	82877	Bolton Mig. Co., Inc.	Washbrook, N.Y.
63743	Ward-Leonard Electric Co.	Mt. Vernon, N.Y.	76433	General Instrument Corp., Micromold Division	Newark, N.J.	82893	Vector Electronic Co.	Glendale, Cal.
64959	Western Electric Co., Inc.	New York, N.Y.	76487	James Miller Mig. Co., Inc.	Malden, Mass.	83058	Carr Eastener Co.	Cambridge, Mass.
65092	Weston Inst. Inc. Weston-Newark	Newark, N.J.	76530	Cinch Monadnock Div. of United Carr Fastener Corp.	San Leandro, Cal.	83086	New Hampshire Ball Bearing, Inc.	Petersborough, N.H.
66295	Wittik Mig. Co.	Chicago, Ill.	76545	Mueller Electric Co.	Cleveland, Ohio	83125	General Instrument Corp., Capacitor Div.	Darlington, S.C.
66346	Minnesota Mining & Mig. Co. Revere Mincom Div.	St. Paul, Minn.	76703	National Union	Newark, N.J.	83186	Victory Eng. Corp.	Springfield, N.J.
70276	Allen Mig. Co.	Hartford, Conn.	76854	Oak Manufacturing Co.	Crystal Lake, Ill.	83298	Bendix Corp., Red Bank Div.	Red Bank, N.J.
70309	Allied Control	New York, N.Y.	77068	The Bendix Corp., Electrodynamics Div.	N. Hollywood, Cal.	83315	Hallbell Corp.	Mundelein, Ill.
70318	Allmetal Screw Product Co., Inc.	Garden City, N.Y.	77075	Pacific Metals Co.	San Francisco, Cal.	83324	Rosan Inc.	Newport Beach, Cal.
70417	Amplex, Div. of Chrysler Corp.	Detroit, Mich.	77221	Phaostroan Instrument and Electronic Co.	So. Pasadena, Cal.	83330	Smith, Herman H., Inc.	Brooklyn, N.Y.
70485	Atlantic India Rubber Works, Inc.	Chicago, Ill.	77252	Philadelphia Steel and Wire Corp.	Philadelphia, Pa.	83332	Tech Labs	Palisades Park, N.J.
70563	Ampertec Co., Inc.	Union City, N.J.	77342	American Machine & Foundry Co. Potter & Brumfield Div.	Princeton, Ind.	83385	Central Screw Co.	Chicago, Ill.
70674	ADC Products Inc.	Minneapolis, Minn.	77630	THW Electronic Components Div.	Camden, N.J.	83501	Gasitt Wire and Cable Co., Div. of Amerace Corp.	Brookfield, Mass.
70903	Beiden Mig. Co.	Chicago, Ill.	77638	General Instrument Corp., Restituter Division	Brooklyn, N.Y.	83504	Burroughs Corp., Electronic Tube Div.	Mainfield, N.J.
70998	Burd Electric Corp.	Cleveland, Ohio	77764	Resistance Products Co.	Brooklyn, N.Y.	83740	Union Carbide Corp., Consumer Prod. Div.	New York, N.Y.
71002	Burnbach Radio Co.	New York, N.Y.	77959	Rubbercraft Corp. of Calif.	Torrance, Cal.	83777	Model Eng. and Mig., Inc.	Huntington, Ind.
71034	Bliley Electric Co., Inc.	Erie, Pa.	78189	Shakerprod Division of Illinois Tool Works	Elgin, Ill.	83821	Lord Saffogs Co.	Fenton, Mo.
71041	Boston Gear Works Div. of Murray Co. of Texas	Quincy, Mass.	78277	Sigma	No. Braintree, Mass.	83942	Aeronautical Inst. & Radio Co.	Yush, N.J.
71278	Bud Radio, Inc.	Willoughby, Ohio	78283	Signal Indicator Corp.	New York, N.Y.	84171	Arco Electronics Inc.	Great Neck, N.Y.
71279	Cambridge Thermionics Corp.	Cambridge, Mass.	78290	Struthers-Dunn Inc.	Pitman, N.J.	84396	A. J. Gleason Co., Inc.	San Francisco, Cal.
72286	Camloc Fastener Corp.	Paramus, N.J.				84411	*HW Capacitor Div.	Ogallala, Neb.
71313	Cardwell Condenser Corp.	Lindenhurst, L.I., N.Y.						
71400	Busamann Mfg. Div. of McGraw-Edison Co.	St. Louis, Mo.						
71436	Chicago Condenser Corp.	Chicago, Ill.						
71447	Calif. Spring Co., Inc.	Pico-Rivera, Cal.						
71500	CTS Corp.	Elkhart, Ind.						
71468	ITT Cannon Electric Inc.	Los Angeles, Cal.						
71471	Cinema, Div. Aerovox Corp.	Burbank, Cal.						

00015-49
Revised May, 1970

From Handbook Supplements
H4-1 Dated January 1970

CODE LIST OF MANUFACTURERS (Continued)

Code No.	Manufacturer	Address	Code No.	Manufacturer	Address	Code No.	Manufacturer	Address
84870	Sarkes Tarstan, Inc.	Bloomington, Ind.	91829	Honeywell Inc., Micro Switch Division	Freeport, Ill.	96095	Hi-Q Div. of AeroVox Corp.	Glenn, N.Y.
85454	Bounton Molding Company	Bounton, N.J.				96256	Thornton-Meisner Inc.	Mc Carrol, Ill.
85471	A. B. Boyd Co.	San Francisco, Cal.	91961	Nahn-Bros. Spring Co.	Oakland, Cal.	96298	Solar Mfg. Co.	Los Angeles, Cal.
85474	R. M. Bracamonte & Co.	San Francisco, Cal.	92180	Tru-Connector Corp.	Prosbury, Mass.	96396	Microswitch, Div. of	
85660	Koiled Kords, Inc.	Hamden, Conn.	92367	Elget Optical Co., Inc.	Rochester, N.Y.		Minn. Honeywell	Freeport, Ill.
85911	Seamless Rubber Co.	Chicago, Ill.	92607	Tensolite Insulated Wire Co., Inc.	Tarrytown, N.Y.	96530	Carlton Screw Co.	Chicago, Ill.
86174	Fafnir Bearing Co.	Los Angeles, Calif.	92702	IMC Magnetics Corp.	Westbury, L.I., N.Y.	96341	Microwave Associates, Inc.	Burlington, Mass.
86197	Clifton Precision Products Co., Inc.	Clifton Heights, Pa.	92966	Hudson Lamp Co.	Kearney, N.J.	96301	Farel Transformer Co.	Oakland, Cal.
86579	Precision Rubber Products Corp.	Dayton, Ohio	93352	Sylvania Electric Prod. Inc., Semiconductor Div.	Woburn, Mass.	96508	Xcelite, Inc.	Orchard Park, N.Y.
86684	Radio Corp. of America, Electronic Comp. & Devices Division	Harrison, N.J.	93369	Robbins & Myers Inc.	Patterson Park, N.J.	96733	San Fernando Elec. Mfg. Co.	San Fernando, Cal.
86928	Seastrom Mfg. Co.	Glendale, Cal.	93410	Siemro Controls, Div. of Essex Wire Corp.	Manfield, Ohio	96881	Thomson Ind. Inc.	Long Island, N.Y.
87034	Marco Industries	Anaheim, Cal.	93632	Waters Mfg. Co.	Culver City, Cal.	97464	Industrial Retaining Ring Co.	Irvington, N.J.
87216	Philco Corporation (Lanadale Division)	Lanadale, Pa.	93929	G.V. Controls	Livingston, N.J.	97519	Automatic & Precision Mfg.	Englewood, N.J.
87473	Western Fibrous Glass Products Co.	San Francisco, Cal.	94137	General Cable Corp.	Bayonne, N.J.	97979	Reon Resistor Corp.	Yonkers, N.Y.
87664	Van Waters & Rogers Inc.	San Francisco, Cal.	94144	Raytheon Co., Comp. Div.	Quincy, Mass.	97983	Litton System Inc., Adler-Westzen Commun. Div.	New Rochelle, N.Y.
87930	Tower Mfg. Corp.	Providence, R.I.	94148	Scientific Electronics Products, Inc.	Loveland, Colo.	98141	R-Tronics, Inc.	Jamaica, N.Y.
88140	Cutler-Hammer, Inc.	Lincoln, Ill.	94154	Wagner Elect. Corp.	Newark, N.J.	98159	Rubber Tech, Inc.	Gardena, Cal.
88220	Gould-National Batteries, Inc.	St. Paul, Minn.	94197	Curtiss-Wright Corp., Electronics Div.	East Patterson, N.J.	98220	Hewlett-Packard Co., Medical Elec. Div.	Pasadena, Cal.
88698	General Mills, Inc.	Buffalo, N.Y.	94222	South Chester Corp.	Chester, Pa.	98278	Micradot, Inc.	So. Pasadena, Cal.
89231	Graybar Electric Co.	Oakland, Cal.	94330	Wire Cloth Products, Inc.	Bellwood, Ill.	98291	Sealstro Corp.	Manassas, N.Y.
89473	G.E. Distributing Corp.	Schenectady, N.Y.	94375	Automatic Metal Products Co.	Brooklyn, N.Y.	98376	Zero Mfg. Co.	Burbank, Cal.
89479	Security Co.	Detroit, Mich.	94682	Worcester Pressed Aluminum Corp.	Worcester, Mass.	98410	Ete Inc.	Cleveland, Ohio
89665	United Transformer Co.	Chicago, Ill.	94686	Magnecral Electric Co.	Chicago, Ill.	98731	General Mills Inc., Electronics Div.	Minneapolis, Minn.
90030	United Shoe Machinery Corp.	Beverly, Mass.	95023	George A. Philbrick Researchers, Inc.	Boston, Mass.	98734	Pacco Division of Hewlett-Packard Co.	Palo Alto, Cal.
90179	U.S. Rubber Co., Consumer Ind. & Plastics Prod. Div.	Pasatic, N.J.	95146	Alco Elect. Mfg. Co.	Lawrence, Mass.	98821	North Hills Electronics, Inc.	Glen Cove, N.Y.
90365	Belleville Speciality Tool Mfg., Inc.	Belleville, Ill.	95236	Allies Products Corp.	Dania, Fla.	98878	International Electronic Research Corp.	Burbank, Cal.
90763	United Carr Fastener Corp.	Chicago, Ill.	95238	Continental Connector Corp.	Woodside, N.Y.	99109	Columbia Technical Corp.	New York, N.Y.
90970	Bearing Engineering Co.	San Francisco, Cal.	95263	Leecraft Mfg. Co., Inc.	Long Island, N.Y.	99313	Varian Associates	Palo Alto, Cal.
91146	ITT Cannon Elect. Inc., Salem Div.	Salem, Mass.	95265	National Coil Co.	Sheridan, Wyo.	99378	Atlee Corp.	Winchester, Mass.
91260	Connor Spring Mfg. Co.	San Francisco, Cal.	95275	Vitramon, Inc.	Bridgeport, Conn.	99515	Marshall Ind., Capacitor Div.	Monrovia, Cal.
91345	Miller Dial & Nameplate Co.	El Monte, Cal.	95348	Gurdos Corp.	Bloomfield, N.J.	99707	Control Switch Division, Controls Co. of America	El Segundo, Cal.
91418	Radio Materials Co.	Chicago, Ill.	95354	Method Mfg. Co.	Rolling Meadows, Ill.	99800	Delevan Electronics Corp.	East Aurora, N.Y.
91506	Augat Inc.	Attleboro, Mass.	95566	Arnold Engineering Co.	Marengo, Ill.	99848	Wilco Corporation	Indianapolis, Ind.
91637	Dale Electronics, Inc.	Columbus, Nebr.	95712	Dago Electric Co., Inc.	Franklin, Ind.	99928	Branson Corp.	Whippany, N.J.
91662	Elco Corp.	Willow Grove, Pa.	95884	Siemon Mfg. Co.	Wayne, Ill.	99934	Rembrandt, Inc.	Boston, Mass.
91673	Epiphone Inc.	New York, N.Y.	95887	Weckesser Co.	Chicago, Ill.	99942	Hoffman Electronics Corp., Semiconductor Division	El Monte, Cal.
91737	Gremar Mfg. Co., Inc.	Wakefield, Mass.	96067	Microwave Assoc., West. Inc.	Sunnyvale, Cal.	99957	Technology-Instrument Corp. of California	Newbury Park, Cal.
91827	K F Development Co.	Redwood City, Cal.						
91886	Malco Mfg., Inc.	Chicago, Ill.						

The following HP Vendors have no number assigned in the latest supplement to the Federal Supply Code for Manufacturers Handbook

0000F	Malco Tool and Die	Los Angeles, Calif.	0000S	Hewlett-Packard Co., Colorado Springs Div.	Colorado Springs, Colorado	0000Q	Cooltron	Oakland, Cal.
0000Z	Willow Leather Products Corp.	Newark, N.J.	000MM	Rubber Eng. & Development	Hayward, Cal.	0000W	California Eastern Lab.	Burlington, Cal.
000AB	ETA	England	000NN	A "N" D Mfg. Co.	San Jose, Cal.	000YY	S K Smith Co.	Los Angeles, Cal.
000BB	Precision Instrument Comp. Co.	Van Nuys, Cal.						

MANUAL BACKDATING CHANGES

Model MODEL 400F/FL

Name AC VOLTMETER

Prefix _____

This manual backdating sheet makes this manual applicable to earlier instruments. Instrument-component values that differ from those in the manual, yet are not listed in the backdating sheet, should be replaced by using the part number given in the manual.

Instrument Serial Prefix	Make Manual Changes	Instrument Serial Prefix	Make Manual Changes
617-00450 and below	1, 2, 3, 4, 6, 8	All	7
617-00451 thru 617-01525	2, 3, 4, 6, 8		
734-01526 thru 734-02775	3, 4, 6, 8		
912-02776 thru 912-02875	4, 5, 6, 8		
912-02876 thru 912-02975	5, 6		
912-02976 thru 912-03475	6		

CHANGE NO. 1

CHANGE NO. 2

Delete diodes A2CR24 through A2CR28 from Figure 7-2, Figure 7-3, and Table 6-1.

Paragraph 5-30(b), change "+ 6 V" to "- 6 V." Figure 7-3:

Change PREAMPLIFIER schematic to the following:

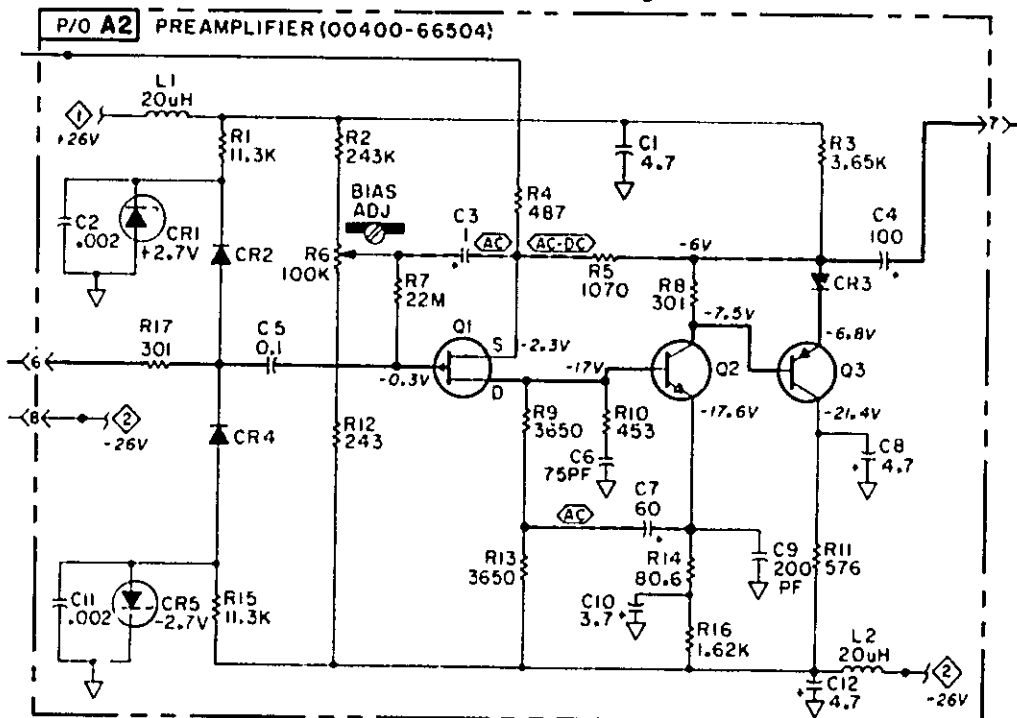

C-1

Table 6-1:

Change A2Q1 to 1855-0052 FET P channel.
Change A2Q2 to 1854-0314 Si NPN.
Change A2Q3 to 1853-0036 Si PNP.

CHANGE NO. 3

Figure 7-3 and Table 6-1:

A2R33, 0757-0474, R:fxd prec met flm 243 kΩ ± 1% 1/8W
A2R39, 0698-3510, R:fxd prec met flm 453 Ω ± 1% 1/8W
A2R40, 0698-3438, R:fxd prec met flm 147 Ω ± 1% 1/8W

CHANGE NO. 4

Figure 7-3 and Table 6-1:

A2R63, 0757-0417, R:fxd prec met flm 562 Ω ± 1% 1/8W

CHANGE NO. 5

Figure 7-3 and Table 6-1:

A2R33, 0698-4125, R:fxd prec met flm 953 Ω ± 1% 1/8W
A2R39, 0698-4422, R:fxd prec met flm 1.27 kΩ ± 1% 1/8W
A2R40, 0698-3488, R:fxd prec met flm 442 Ω ± 1% 1/8W

CHANGE NO. 6

Table 6-1:

J4, 1251-0148, Connector: ac power cord receptacle, 87930,
H-1061-2
MP24, 00400-00206, Panel: rear, -hp-
8120-0078, Cord: power

CHANGE NO. 7

The part numbers listed are for brown instruments. The
part numbers for blue instruments are shown below.

MP22	00400-64102	Cover Assy: top
MP25	5000-0703	Cover Assy: side
MP26	5000-0711	Cover Assy: bottom
MP30	00400-00207	Panel: front (400FL)
	00400-00208	Panel: front (400F)
MP31	5020-0704	Trim: meter (400FL)
	5030-5388	Trim: meter (400F)

CHANGE NO. 8

Table 6-1:

A2R63*, 0698-4468, R:fxd flm 1.13 kΩ ± 1% 1/8W

MANUAL CHANGES

MODEL 400F/FL

AC VOLTMETER

Manual Part No. G0400-90016

■ New or Revised Item



CHANGE NO. 1 applies to serial number 0950A-08336 and above for the 400F and serial number 0950A-08286 and above for the 400FL.

Page 6-7, Table 6-1. Add to the replaceable parts the following:

-hp- Part No. 1510-0038, TQ:1, description:BDG post-single (located on rear panel).

-hp- Part No. 7120-4609, TQ:1 description: Warning Label.

CHANGE NO. 2 applies to serial number 0950A-08726 and above for the 400F and serial number 0950A-08766 and above for the 400FL.

Page 3-0 and 3-1, Figure 3-1 and 3-2. Change  to 

Page 6-2, Figure 6-1. Change rear panel drawing to Figure CS1 of change sheet.

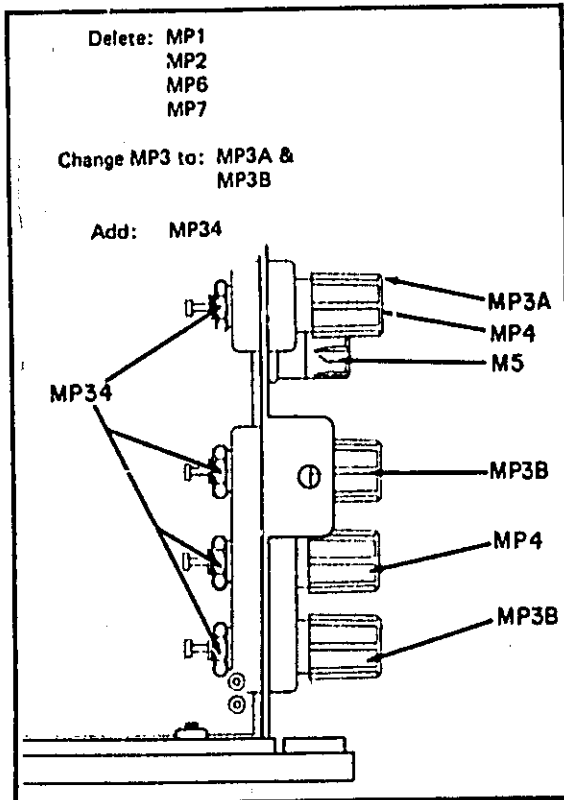

FIGURE CS1

22 November 1977

Page 6-6, Table 6-1. Delete the following parts:

MP1	0340-0090
MP2	0340-0086
MP6	0340-0087
MP7	0340-0091

Change the part numbers for the following reference designator:

	From	To
MP3	1510-0010	MP3A 1510-0090 TQ1 MP3B 1510-0091 TQ2
MP4	1510-0011	1510-0107 TQ2
MP12	1510-0035	1510-0087 TQ1
MP13	1510-0036	1510-0084 TQ1
MP14	0340-0099	0340-0732 TQ2
MP15	0340-0160	0340-0732
MP24	00400-00210	00400-00212

Add: MP34 2950-4144 TQ5

CHANGE NO. 3 applies to serial number 0950A-09386 and above for the 400F and serial number 0950A-09406 and above for the 400FL.

Page 6-4, Table 6-1. Change part number and description of A2C28 from 130 pF 0140-0195 to 82 pF 0140-0193 and add a star to reference designator.

Page 7-3/7-4, Figure 7-2. On the schematic place a star next to C28 and change the value to 82 pF.

CHANGE NO. 4 applies to serial numbers 0950A09786 and above for the 400F and serial number 0950A09836 and above for the 400FL.

Page 6-6, Table 6-1. Change the Part Number and Description for MP5 from 1400-0084--Holder:Fuse to 2110-0470--Fuhir--Extr Post and 2110-0465--Cap. Add the following part numbers and description as required hardware:

2110-0467	Nut Hex	Qty. 1
1400-0090	Washer	Qty. 1
2190-0054	Washer	Qty. 1

CHANGE NO. 5 applies to serial numbers 0950A10085 and above for the 400F and serial numbers 0950A10036 and above for the 400FL.

Supplement A for 00400-90016

Table 6-1 on Pages 6-3, 6-4, 6-5. Change the part numbers for the following reference designators:

	<u>From</u>	<u>To</u>	<u>Description</u>
A2	00400-66504	00400-66514	Same
A2R6	2100-0095	2100-3214	R:Var Comp Lin 100 k Ω \pm 10% 0.10 W
A2R68	2100-0277	2100-0568	Res:Var, 100 Ω \pm 10% 0.3 W

Page 6-4. Add to A2C37* -hp- part number 0140-0201 the following padding list:

5 pF 500 V 0160-0763
18 pF 300 V 0160-0366

Page 6-5. Add to A2C63* -hp- part number 0698-4458 the following padding list:

499 ohm .01 0698-4123
681 ohm .01 0757-0419

Page 7-3/7-4, Figure 7-2. Change A2 board from -hp- part number 00400-66504 to 00400-66514.

CHANGE NO. 6 applies to serial numbers 0950A10206 and above for the 400F and serial numbers 0950A10176 and above for the 400FL.

Page 6-4. Change A2C38, C39 from -hp- part number 0180-0393 to 0180-2795, C:Fxd Ta 39UF \pm 10% 10 VDC W.

CHANGE NO. 7 applies to all serial numbers.

Page 1-1. Add the following paragraph between 1-3 and 1-4.

Options.

Option 910. An additional Operating and Service Manual part number 00400-90016.

MANUAL CHANGES

Manual for Model Number	400F/FL
Manual printed on	July 1974
Manual Part Number	00400-90016

Make all ERRATA corrections.

Check the following table for your instrument serial prefix/serial number and make the listed changes to your manual.

▶ New Item

Serial Prefix or Serial Number		Manual Changes	Serial Prefix or Serial Number	Manual Changes
1212G01321	and above	1		
1202G01426	and above	1-2		
1202G01591	and above	1-3		
1641G01681	and above	1-4		

MODEL 400F/FL INDEX OF MANUAL CHANGES

MANUAL CHANGE	A1	A2	FRAME				
1	C1,2,3,6	C5,18,22, C41,6 CR22,03 R5,10,60 R69	NP24,30, MP31,32 DS1, S3				
2			MP5				
3			MP1,2,3,4 MP6,7,12, MP13,24 Binding - Post				
4			C2, S3,4 MP24				

MANUAL CHANGE 1

On Table 6-1, change the Table of Replaceable Parts to read:

A1C1	0160-2902	C:FXD CER 0.01UF + 20% 1000V
A1C2	0132-0003	C:VAR TRIMMER 3.0PF
A1C3,6	0160-2930	C:FXD CER 0.01UF +80 -20% 100V
A2C5	0160-2914	C:FXD CER 0.1UF +80 -20% 50V
A2C18,22	0160-2897	C:FXD CER 0.02UF +80 -20% 600V
A2C41	0160-2940	C:FXD MICA 470PF +5% 300V
A2C6	DELETE	
A2R10	DELETE	
A2CR22	1901-0535	DIODE HOT CARRIER
A2Q3	1854-0329	TRANSISTOR SI NPN
A2R5	0698-4125	R:FXD FILM 953 OHM + 1% 1/8W
A2R60*	0757-0392	VALUE SELECTED AT FACTORY, LOWEST VALUE 43.2 OHM.
A2R69	0757-1097	R:FXD FILM 1.2K + 1% 1/8W
MP24	00400-10006	PANEL REAR
MP30	00400-00102	PANEL FRONT
MP31	5020-7633	TRIM METER
MP32	5060-0703	BRACKET: COVER RETAINER
DS1	1450-0419	LAMP - PILOT
S3	3101-0030	SWITCH TOGGLE

For Instruments equipped with German "Schuko" Power cable change power cord to 8120-1689

MANUAL CHANGE 2

On Table 6-1, change the Holder Fuse 1400-0084 to the following Components:

MP5	2110-0470	FUSEHOLDER BODY
MP5	1400-0090	WASHER NEOPRENE
MP5	2190-0054	WASHER LOCK
MP5	2110-0467	NUT HEX (METALLIC)
MP5	2110-0465	FUSEHOLDER CAP

MANUAL CHANGE 3

On Table 6-1, change the Table of Replaceable Parts to read:

MP24	00400-60212	PANEL ASSY REAR
MP1,2,3,4,6,7,12,13	DELETE	
	0340-0732	INSULATOR BINDING POST
	1510-0084	BINDING POST
	1510-0087	BINDING POST
	1510-0090	BINDING POST
	1510-0091	BINDING POST
	1510-0107	BINDING POST
	2950-0144	NUT NYLON, 3/8 - 32

NOTE: The components listed above can be identified on the diagram shown below:

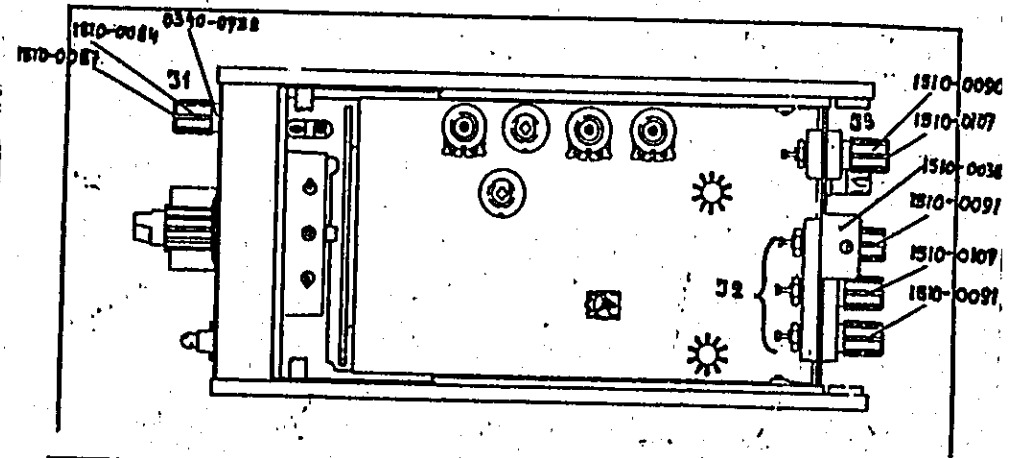

MANUAL CHANGE 4

On Table 6-1, change the Table of Replaceable Parts to read:

C2	0160-4048	C:FXD .022UF ACROSS J4
S3	3101-2147	SW SPST
S4	3101-1740	SW SLIDE
MP24	00400-00246	PANEL ASSY REAR
	1510-0038	BINDING POST

Free Manuals Download Website

<http://myh66.com>

<http://usermanuals.us>

<http://www.somanuals.com>

<http://www.4manuals.cc>

<http://www.manual-lib.com>

<http://www.404manual.com>

<http://www.luxmanual.com>

<http://aubethermostatmanual.com>

Golf course search by state

<http://golfingnear.com>

Email search by domain

<http://emailbydomain.com>

Auto manuals search

<http://auto.somanuals.com>

TV manuals search

<http://tv.somanuals.com>