

**HP**

**LaserJet**

**3150**

Getting  
Started  
Guide

HP  
**CUSTOMER  
CARE**



Store your LaserJet 3150 software CD here.



If you ever have to contact HP Customer Care, you will need the model and serial numbers (located on the back of the HP LaserJet 3150 product) and the date you purchased the product. Write the information here:

Model number: \_\_\_\_\_

Serial number: \_\_\_\_\_

Date of purchase: \_\_\_\_\_

---

Remove paper from the input tray before loading more paper to ensure proper paper feeding. Attach this label to the product as a reminder.

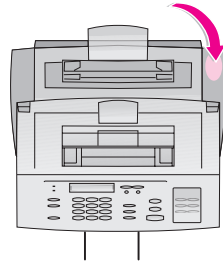



---

# HP LaserJet 3150 Product

## **Getting Started Guide**

## Copyright Information

© 1999 Hewlett-Packard Company

All Rights Reserved.  
Reproduction, adaptations, or translation without prior written permission is prohibited except as allowed under copyright laws.

Part Number: C4256-90922  
First Edition, February 2000

## Warranty

The information contained in this document is subject to change without notice.

Hewlett-Packard makes no warranty of any kind with respect to this information. HEWLETT-PACKARD SPECIFICALLY DISCLAIMS THE IMPLIED WARRANTY OF MERCHANTABILITY AND FITNESS FOR A PARTICULAR PURPOSE

Hewlett-Packard shall not be liable for any direct, indirect, incidental, consequential, or other damage alleged in connection with the furnishing or use of this information.

NOTICE TO U.S. GOVERNMENT USERS: RESTRICTED RIGHTS COMMERCIAL COMPUTER SOFTWARE: Use, duplication, or disclosure by the Government is subject to restrictions as set forth in subparagraph (c)(1)(ii) of the Rights in Technical Data Clause at DFARS 52.227-7013.

Material scanned by this product may be protected by governmental laws and other regulations, such as copyright laws. The customer is solely responsible for complying with all such laws and regulations.

Hewlett-Packard Company  
11311 Chinden Boulevard  
Boise, Idaho 83714 U.S.A.

## Trademark Credits

JetSuite is a trademark of eFax.com, Inc. Microsoft, Windows, and MS-DOS are U.S. registered trademarks of Microsoft Corporation. ENERGY STAR is a U.S. registered service mark of the U.S. EPA. CompuServe is a trademark of CompuServe, Inc. All other products mentioned herein may be trademarks of their respective companies.

### This product is approved for use in the following countries only:

**Australia, India, Ireland, Malaysia, Singapore, and South Africa.**

Local country laws may prohibit the use of this product outside of the countries specified. It is strictly forbidden by law in most countries to connect nonapproved telecommunications equipment (fax machines) to public telephone networks.



### Safety Information WARNING!

#### Potential Shock Hazard

Always follow basic safety precautions when using this product to reduce risk of injury from fire or electric shock.

- 1 Read and understand all instructions in the user guide.
- 2 Observe all warnings and instructions marked on the product.

- 3 Use only a grounded electrical outlet when connecting the HP LaserJet 3150 product to a power source. If you don't know whether the outlet is grounded, check with a qualified electrician.
- 4 Do not touch the contacts on the end of the telephone cord or any of the sockets on the HP LaserJet 3150 product. Replace damaged cords immediately.
- 5 Never install telephone wiring during a lightning storm.
- 6 Unplug this product from wall outlets and telephone jacks before cleaning.
- 7 Do not install or use this product near water or when you are wet.
- 8 Install the product securely on a stable surface.
- 9 Install the product in a protected location where no one can step on or trip over the line cord and the line cord will not be damaged.
- 10 If the product does not operate normally, see chapter 8 in the *user guide*.
- 11 Refer all servicing questions to qualified personnel.

Information regarding FCC Class B, Parts 15 and 68 requirements can be found in Appendix A in the *user guide*.

---

# Contents

Introduction . . . . .	7
Checking the box contents . . . . .	8
Recording important information. . . . .	9
Choosing an installation . . . . .	10
Checking the phone line and computer. . . . .	11

## 1 Installing hardware

Identifying parts. . . . .	15
Installing the toner cartridge . . . . .	18
Attaching supports. . . . .	20
Attaching the paper loading label . . . . .	21
Loading paper . . . . .	22
Connecting the product to the phone line . . . . .	23
Connecting only the HP LaserJet 3150 product . . . . .	23
Connecting the HP LaserJet 3150 product and other devices . . . . .	24
Connecting other devices to the phone line . . . . .	25
Deciding what else to connect . . . . .	25
Connecting other devices, overview. . . . .	27
Connecting the product power cord . . . . .	31
Testing the hardware . . . . .	33

## 2 Finishing the installation

Option A: Connecting directly to a computer. . . . .	35
Connecting to a computer. . . . .	36
Preparing for software installation . . . . .	37
a. Installing the software for a directly connected computer. . . . .	39
b. Printing a document as a test . . . . .	40
Sharing the product . . . . .	41
Option B: Connecting to a network . . . . .	42
Preparing for software installation . . . . .	43
a. Installing software for network computers . . . . .	44
b. Printing a document as a test . . . . .	45
Option C: Completing a standalone installation . . . . .	46
a. Setting the time and date . . . . .	47
b. Setting the fax header. . . . .	48
c. Setting answer mode and rings to answer . . . . .	50
d. Enabling distinctive ring detection . . . . .	52
e. Printing a self-test report . . . . .	54
Troubleshooting . . . . .	55
HP Customer Care . . . . .	58

---

### 3 Exploring the product and software

What you will learn . . . . .	60
Exploring the product . . . . .	61
Loading items to be faxed, copied, or scanned . . . . .	61
Sending a fax using the control panel . . . . .	62
Exploring the software. . . . .	63
Overview. . . . .	63
Sending a fax using the Document Assistant . . . . .	68
Making a copy using the Document Assistant . . . . .	69
Scanning an item . . . . .	70
Scanning to text using OCR . . . . .	72
Taking the next step . . . . .	73

### 4 Warranty

Warranty information. . . . .	74
Hewlett-Packard limited warranty statement . . . . .	74
Year 2000 warranty . . . . .	76

### Index



---

# Getting Started Guide

## Introduction

Thank you for purchasing the HP LaserJet 3150 product, a powerful business tool with the capabilities of a full range of office equipment: use it to print, fax, copy, and scan. Increase your productivity by doing more than one task at a time. Send an electronic fax while the HP LaserJet 3150 product makes copies, or scan a document while printing.

Using this guide, you will check the box contents and phone line and computer requirements. Then, the guide leads you through setting up the product and learning how to do the most basic tasks in three easy sections:

- 1 Installing hardware.** Connect parts such as cables and supports.
- 2 Finishing the installation.** Connect the product directly to a computer using a parallel cable, connect the product to the network using a HP JetDirect print server, or not to connect the product at all (standalone). If you can connect the product to a computer or network, HP strongly recommends doing so and installing the software. This gives you the maximum product functionality.
- 3 Exploring the product and software.** Discover how to do basic tasks and get up and running quickly with your new HP LaserJet 3150 product.

At the end of each procedure in this guide is this paragraph:

### **Check your work**

Use it to ensure that you completed the procedure successfully, or to find the next one you need.



## Checking the box contents

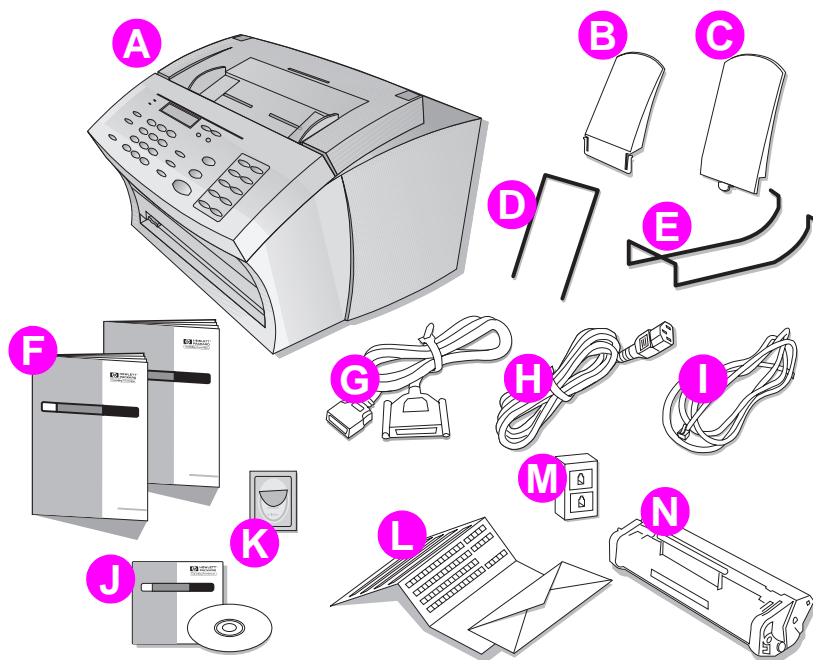

Unpack the box and check that it includes the following items:

- |  |                                      |
|--|--------------------------------------|
| <b>A</b> HP LaserJet 3150 product                                  | <b>H</b> Power Cord                  |
| <b>B</b> Paper Output Support                                      | <b>I</b> Telephone Cord              |
| <b>C</b> Paper Input Support                                       | <b>J</b> Software on CD-ROM          |
| <b>D</b> Document Feeder Support                                   | <b>K</b> Paper Loading Label         |
| <b>E</b> Document Output Support                                   | <b>L</b> Product Registration Packet |
| <b>F</b> Documentation (User Guide and this Getting Started Guide) | <b>M</b> Modular Double Adaptor      |
| <b>G</b> IEEE-1284 Compliant Parallel Cable (with a "C" Connector) | <b>N</b> HP LaserJet Toner Cartridge |

Save the box and packing material in case you need to move or ship the HP LaserJet 3150 product later.

---

## Check your work

Does the package contain all of the items?

**Yes.** Go to "Recording important information" below.

**No.** Do one of the following:

- Contact your dealer for instructions regarding obtaining the missing part or parts.
- If you are missing the software and have Internet access, visit the website at [www.hp.com/go/support/lj3150](http://www.hp.com/go/support/lj3150) and download the software from there.
- Gather this information: the product serial number and model number (on the back of the product), the item missing, and the purchase date. Then, call HP Customer Care at:

Australia: +61 3 8877 8000

India: 91 11 682 6035

Ireland: +353 (0)1 662 5525

Malaysia: +60 3 295 2566

Singapore: +65 272 5300

South Africa: +27 (0)11 8061030

When you are ready, go to "Recording important information" below.

## Recording important information

If you ever have to contact HP Customer Care, you will need the product model number and serial number, located on the back of the HP LaserJet 3150 product. Take a moment now to record the information on the inside front cover of this guide. Because you will also need the date of purchase, HP recommends storing your dated sales receipt or proof of purchase in the pocket on the inside back cover of this guide.

## Check your work

When you are ready, go to "Choosing an installation" on page 10.



## Choosing an installation

The HP LaserJet 3150 product can function in one of three installations: as a standalone fax and copier not connected to a computer, connected to a network using an HP JetDirect print server, or directly connected to a computer. If it is connected to a computer on the local area network (LAN), you can share the product with other network users.

The product works in any of these situations, but feature availability varies. This table shows which features are available depending on how you connect the product.

Feature or Function:	Connected directly to computer, local user*	Connected directly to computer (shared), other users**	Connected to network via HP JetDirect print server	Stand-alone fax and copier, no software
Faxing to and from the HP LaserJet 3150 product (walk-up)	✓	✓	✓	✓
Copying from the HP LaserJet 3150 product (walk-up)	✓	✓	✓	✓
Access through the control panel to HP LaserJet 3150 product setup options, fax and copy options, and setup for one-touch keys and speed-dial and group-dial codes (walk-up)	✓	✓	✓	✓
Printing from your computer to the HP LaserJet 3150 product	✓	✓	✓	
Access to PC Fax Phone Books	✓		✓	
Scanning from the HP LaserJet 3150 product to your computer	✓		✓	
Faxing electronic documents from your computer (PC faxing)	✓		✓	
Optical character recognition (OCR) software for converting scanned images to editable text documents	✓		✓	
Receiving faxes to your computer (PC faxing)	✓			
Access to special copying features, such as two or four pages per sheet (2 up and 4 up) and collation for very large documents	✓			
Quick access through the software to HP LaserJet 3150 product setup options, fax options, and setup for one-touch keys and speed-dial codes	✓			

\* Available to user of the computer directly connected to the product.

\*\* Available to other users on the network when Windows sharing is enabled from the computer directly connected to the product.



## Checking the phone line and computer

Before you begin connecting the hardware, make sure that you meet the requirements for the phone line. If you are installing software, also ensure that your computer or network meets the requirements.

### Checking phone line requirements

You can connect the HP LaserJet 3150 product to a phone line only for fax calls (a dedicated line) or a phone line for both voice calls and fax calls (a shared line). In most cases, you can choose either one. However, the HP LaserJet 3150 product cannot work with digital telephone lines (only with analog) and might not be able to work on a shared line with telephone system features such as the automatic answering systems often used in large companies, voice mail, call waiting, and some other advanced features provided by your local telephone company.

- **Important!** If you are trying to connect the product to a line for both fax and voice calls (a shared line) and have the types of telephone system features mentioned above, HP recommends getting a second phone line dedicated to fax calls.
- **Caution!** If you live in an area that is subject to frequent electrical storms or for other reasons experiences numerous blackouts, it is strongly recommended that you purchase and use a telephone line surge protector. Electrical surges and power interruptions can damage the HP LaserJet 3150 product.

### Check your work

Have you decided to get a telephone line surge protector or second phone line?

- No.** If you are going to install the software, go to “Checking computer or network requirements” on page 12. Otherwise, go to “Installing hardware” on page 15.
- Yes.** If you need a second phone line, contact your local phone company. If you need a telephone line surge protector, you can obtain one from your local computer or electronics retailer.

Once you resolve these issues, go to “Checking computer or network requirements” on page 12 if you are installing software. Otherwise, go to “Installing hardware” on page 15.

---

## Checking computer or network requirements

If you are installing software, your computer or network needs to meet the following minimum requirements.

### Connecting directly to a computer using a parallel cable

If you are connecting the product directly to a computer using a parallel cable, your computer:

- must be an IBM computer (or 100% compatible) with a 486 33 MHz processor or better (Pentium® 90 MHz processor or better for Microsoft® Windows NT 4.0 or 2000).
- must be running Windows 3.1x, 9x, NT 4.0, or 2000.
- must have 16 megabytes (MB) or more of random access memory (RAM) for Windows 3.1x or 9x; 32 MB or more of RAM for Windows NT 4.0 or 2000.
- must have 65 MB or more of free hard-disk space.
- should have a dedicated, IEEE-1284 bidirectional or ECP-compliant parallel port to which the HP LaserJet 3150 product can be connected directly. If you have a device such as an external disk drive or switch box connected to the computer's parallel port, you might have to unhook the device to connect and use the HP LaserJet 3150 product, or use two parallel ports on the computer.

### Connecting to a network using an HP JetDirect print server

The computers that will be using the product software need to meet the following requirements:

- must be an IBM computer (or 100% compatible) with a 486 33 MHz processor or better (Pentium 90 MHz processor or better for Windows NT 4.0 or 2000).
- must be running Windows 9x, NT 4.0, or 2000.
- must have 16 megabytes or more of RAM for Windows 9x; 32 MB or more of RAM for Windows NT 4.0 or 2000.
- must have 65 MB or more of free hard-disk space.

---

For the network, you need the following:

- You must have an installed network using the TCP/IP or IPX/SPX network protocol. Circle the one you have. If you do not know, ask the person who installed your network. (If you are using the IPX/SPX network protocol, you must configure the HP JetDirect print server using Direct mode, *not* Queue Server mode. Also, Novell servers are *not* supported.)
- You need a cable for your type of network connection (not included). This cable is used to connect the print server to a network jack. If you do not know what type you need, ask the person who installed your network.
- You need a supported HP JetDirect print server (not included). Which one you use depends on the type of network connection you have and how many devices you need to connect to the print server.
  - **HP JetDirect 170X (J3258B — J3258A is *not* supported).** You can use this model if you have a 10Base-T network connection and only need to connect the product to this print server.
  - **HP JetDirect 300X (J3263) with a firmware revision of H.08.00 or higher\*.** Use this model if you have a 10Base-T or 10/100Base-TX network connection and only need to connect the product to this print server.
  - **HP JetDirect 500X (J3265) with a firmware revision of J.08.00 or higher\*.** Use this model if you have a BNC, 10Base-T, or 10/100Base-TX network connection and need to connect the product and up to two other devices to this print server.
  - **HP JetDirect 500X (J3264) with a firmware revision of J.08.00 or higher\*.** Use this model if you have a Token Ring network connection. You can connect the product and up to two other devices to this print server.

Circle the one you have or you are buying.

\* You can check the firmware revision number by printing a configuration page for the print server. Instructions for printing the configuration page and checking and upgrading firmware appear later in the setup process in the "Option B: Connecting to a network" section.

---

## Check your work

Does your computer or network meet the requirements?

- Yes.** You are ready to begin. Go to “Installing hardware” on page 15.
- No.** Either you will not be able to install the software, or it might not work correctly. Do one of the following:
  - Install the software on a computer that meets the requirements. Use the software and product with that computer.
  - Use the HP LaserJet 3150 product without installing the software. The product will still work as a fax machine and convenience copier.
  - Upgrade your computer, network, or HP JetDirect print server to meet the requirements. If you need a new print server, see page 13 for a list of supported HP JetDirect print servers.

Once you resolve these issues, go to “Installing hardware” on page 15.



# 1 Installing hardware

In this section, you will connect or install all of the parts, such as cables and the toner cartridge. *Before beginning, make sure to place the product on a sturdy, level surface in a well-ventilated area.*



## Identifying parts

Before setting up the HP LaserJet 3150 product, make sure you can identify the following parts related to the scanner path and paper print path.

### Identifying scanner path parts

Items to be faxed, copied, or scanned use the scanner path, which consists of the following parts:

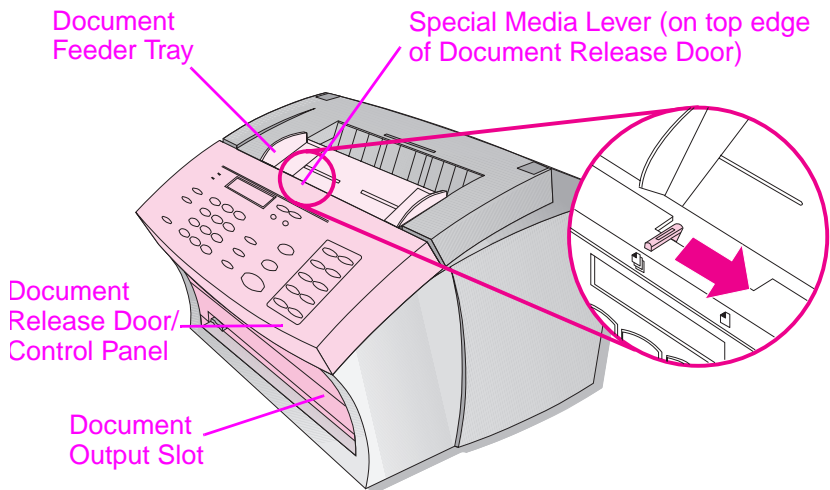

## Identifying printer path parts

Paper for printing, receiving faxes, and copy output follows the printer path. This path consists of the following parts:

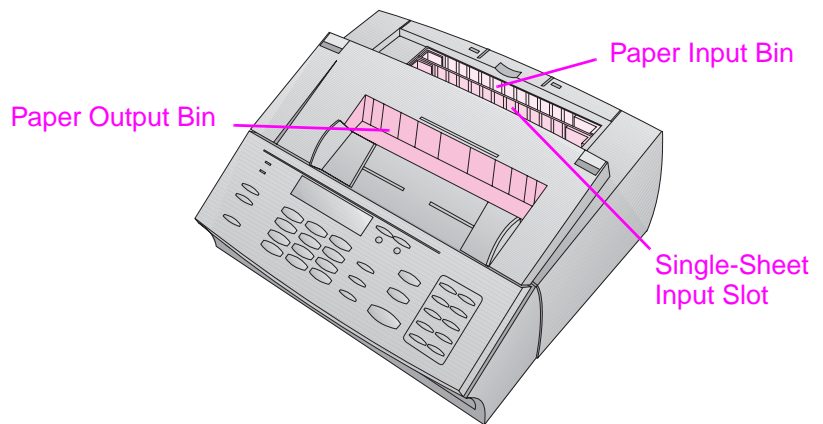
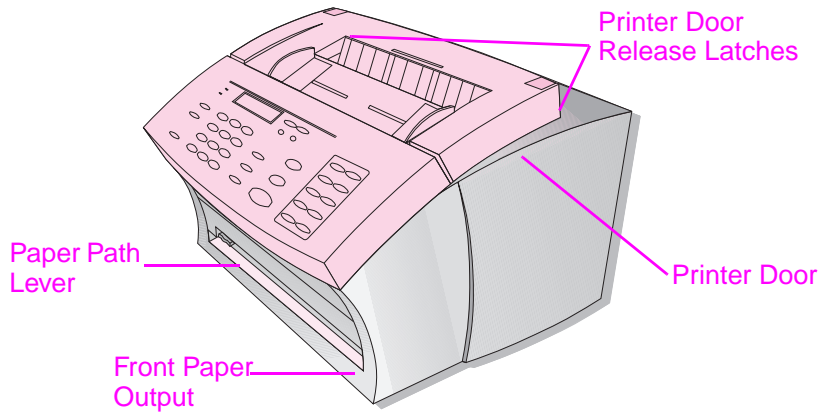

## Identifying control panel features

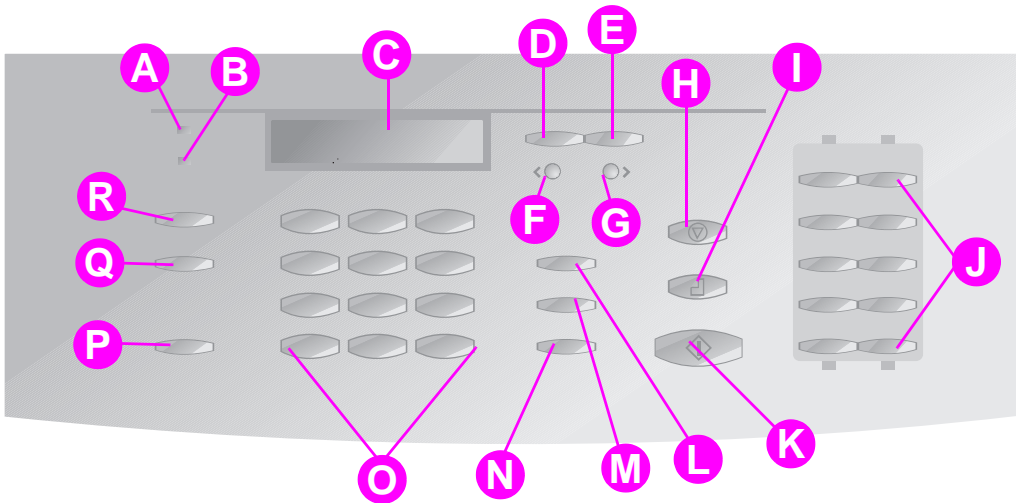

Look for the following keys and features on the control panel. They are used to fax paper-based documents, make copies, and adjust settings for the HP LaserJet 3150 product.

- |   |  |
|---|--|
| <b>A</b> <b>Ready Light</b> – When solid, indicates the HP LaserJet 3150 product is ready and has no error conditions.                            | <b>J</b> <b>One-touch keys</b> – Store frequently dialed fax numbers.  |
| <b>B</b> <b>Error light</b> – When solid, indicates an error condition.   | <b>K</b> <b>Start key</b> – Starts sending paper faxes. Also starts scans in network mode.   |
| <b>C</b> <b>Control Panel Display</b> – Displays messages or Menu settings.   | <b>L</b> <b>Manual Dial key</b> – Use to dial each digit as it is pressed. Often used for dialing with calling cards or international dialing.               |
| <b>D</b> <b>Enter/Menu key</b> – Use to gain access to the Menu, save a selection, or go down one level in the Menu settings.                     | <b>M</b> <b>Speed-Dial key</b> – Press this key plus a one-, two- or three-digit code to fax or e-mail to previously stored fax numbers or e-mail addresses. |
| <b>E</b> <b>Back Space key</b> – Use to go up one level in the Menu settings or to backspace when typing text.                                    | <b>N</b> <b>Redial/Pause key</b> – Press to redial the last fax number or use to insert a pause into a fax number.   |
| <b>F</b> <b>Back Arrow key</b> (<) – Use to scroll back through items at the same Menu level or move back through text.                           | <b>O</b> <b>Numeric keys</b> – Use to enter fax numbers. Also use to add letters when typing a name in the fax header or for speed-dials.                    |
| <b>G</b> <b>Forward Arrow key</b> (>) – Used to scroll forward through items at the same Menu level. Also use to insert a space when typing text. | <b>P</b> <b>Volume key</b> – Use to adjust the volume for incoming and outgoing fax connection sounds.   |
| <b>H</b> <b>Stop/Clear key</b> – Stops or clears any action in progress or exits the Menu settings.   | <b>Q</b> <b>Resolution key</b> – Use to adjust the resolution, or sharpness, for the current fax or copy job.  |
| <b>I</b> <b>Copy key</b> – Starts the copy function.  | <b>R</b> <b>Contrast key</b> – Use to adjust the contrast, or difference between light and dark areas, for the current fax or copy job.                      |

### Check your work

When you are ready, go to “Installing the toner cartridge” on page 18.



## Installing the toner cartridge

1

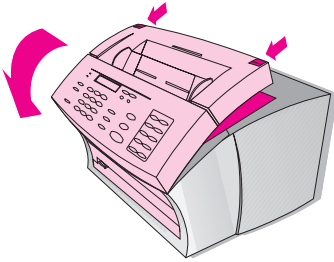

2

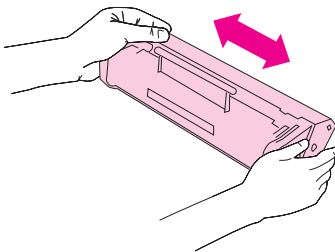

3

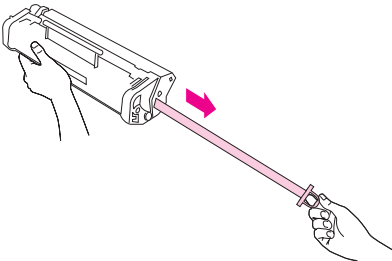

4

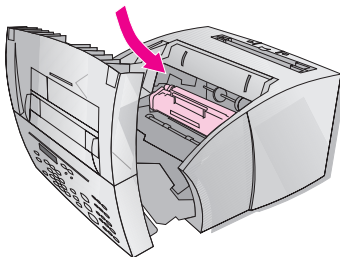

HP recommends using HP LaserJet toner cartridges, such as the one included in the box. HP has designed its HP LaserJet 3150 product and toner cartridges to work together to give you optimal image quality and reliability.

### CAUTION!

To prevent damage, do not expose the toner cartridge to light for more than a few minutes.

### To install the toner cartridge

- 1 Use the two printer door release latches to pull open the printer door.
- 2 Shake the toner cartridge several times from side to side (about two times per second) to distribute the toner evenly.
- 3 Grasp the end of the clear sealing tape on the side of the cartridge and pull firmly to remove the entire length of the tape (about twice as long as the cartridge).
- 4 Hold the cartridge by the handle (so that the arrows are facing the HP LaserJet 3150 product) and slide the cartridge into the black grooves in the product. Rotate the cartridge firmly into place and close the printer door.

### Note

If toner gets on your clothing, wipe it off with a dry cloth and wash clothing in cold water. Hot water and heat from the dryer set toner into fabric.

---

## Check your work

Did you remove the tape strip, and did the printer door latch securely?

**Yes.** Go to “Attaching supports” on page 20.

**No.** Do the following:

- Make sure to remove the tape strip.
- Open and close the printer door again. If it still does not latch, the toner cartridge may not be completely seated. Remove the toner cartridge and reinsert it.

## Recycling toner cartridges

To reduce landfill waste, HP has adopted a recycling program for toner cartridges. When you replace an empty HP LaserJet toner cartridge, follow the instructions in the box of the new toner cartridge to recycle the empty one. You can return the empty toner cartridge free of charge using a postage-paid shipping label found inside the new toner cartridge box.

Since 1990, the HP LaserJet Toner Cartridge Recycling Program has collected more than 25 million used HP LaserJet cartridges that otherwise may have been discarded in the world's landfills.



## Attaching supports

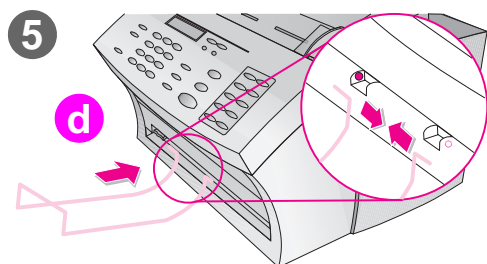
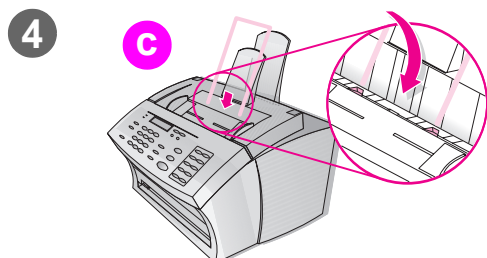
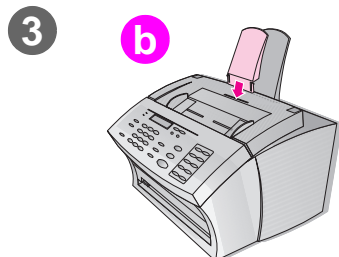
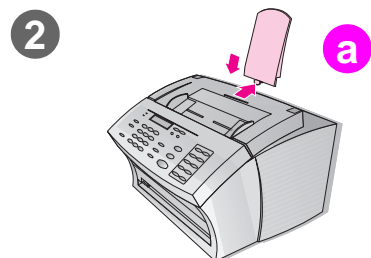
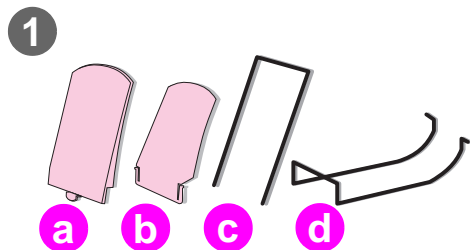

There are four supports you need to install to support media or items feeding into or coming out of the HP LaserJet 3150 product.

### To attach supports

- 1 Locate the:
  - paper input support (a),
  - paper output support (b),
  - document feeder support (c),
  - document output support (d).
- 2 Align the paper input support (a) with the groove on the paper input bin and push the guide straight back into the groove.
- 3 Insert the paper output support (b) into the groove on the paper output bin.
- 4 Insert the document feeder support (c) into the grooves on the back of the document feeder tray.
- 5 Squeeze the ends of the document output support (d), insert it into the holes on document output slot, and release the support.

### ✓ Check your work

When you have attached the supports, go to “Attaching the paper loading label” on page 21.



## Attaching the paper loading label

2



3

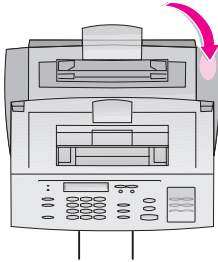

Attach the label titled “Remove Paper Before Reloading” to the HP LaserJet 3150 product.

### To attach the label

- 1 Locate the label that was shipped in the front of this guide.
- 2 Carefully remove the label from its backing sheet.
- 3 Attach the label to the HP LaserJet 3150 product near the paper input bin.

As the label indicates, always remove and realign all paper together before reloading. This reduces multiple feeds and jams.

### Check your work

When you have attached the label, go to “Loading paper” on page 22.



## Loading paper

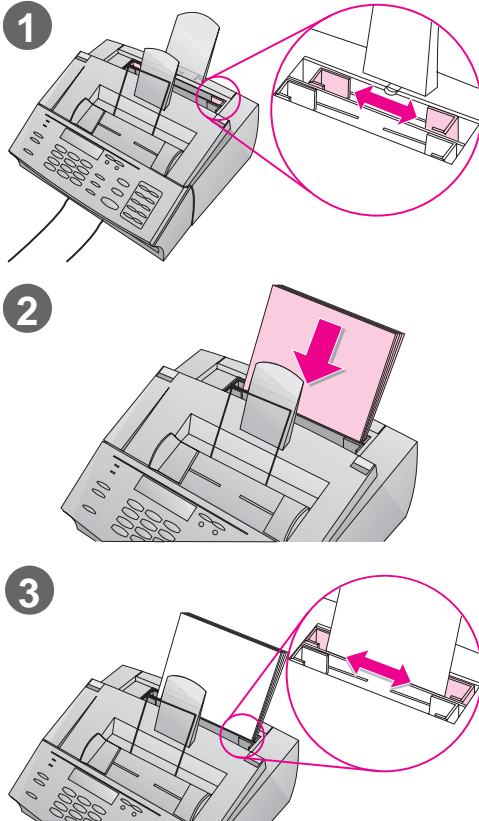

You can load up to 100 sheets of 20 lb (75 g/m<sup>2</sup>) paper into the paper input bin. The HP LaserJet 3150 product prints, copies, and prints received faxes using media from the paper input bin (or the single-sheet input slot).

### To load the paper input bin

- 1 Adjust the guides on the paper input bin to the size of media you are loading.
- 2 Insert up to 100 sheets of paper into the paper input bin. Be careful not to overfill the bin.

---

#### Note

When adding paper to an existing stack in the paper input bin, always remove the existing paper and realign it with the new paper before loading to reduce multiple feeds or jams.

---

- 3 Readjust the guides to fit snugly against the edges of the stack.

### Check your work

After you have loaded the paper, go to “Connecting the product to the phone line” on page 23.





## Connecting the product to the phone line

In order for the HP LaserJet 3150 product to fax properly, it must be the first device connected to the wall socket. Choose one of the following two ways to connect the product.

### CAUTION!

**For South Africa only:** External overvoltage protection must be installed if the HP LaserJet 3150 product is to be connected directly to a public telephone network terminal. Failure to do so can damage the product. For more information, contact your local HP dealer.

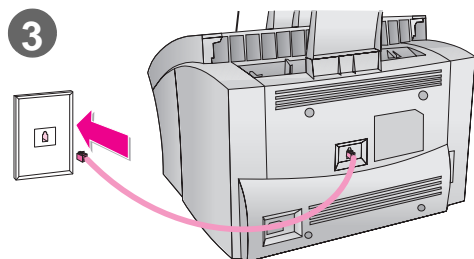
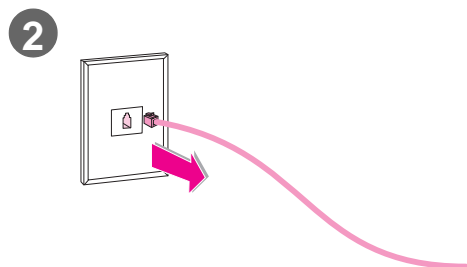
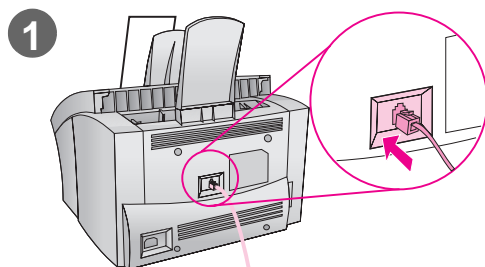

### Connecting only the HP LaserJet 3150 product

Use this procedure if you are only connecting the HP LaserJet 3150 product to this wall socket.

#### Note

If you do not have an RJ11 socket or an RJ11 adaptor did not come with the HP LaserJet 3150 product, you must buy and install an adaptor to convert the wall socket to an RJ11 socket.

### To connect only the HP LaserJet 3150 product

- 1 Plug the included telephone cord into the socket on the back of the HP LaserJet 3150 product.
- 2 If any telephone cord is plugged into the wall socket, unplug it and set it aside.
- 3 Plug the other end of the cord into the wall socket.

#### Check your work

Go to "Connecting the product power cord" on page 31.

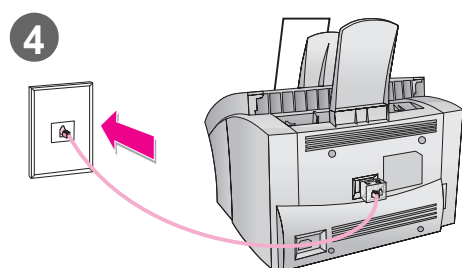
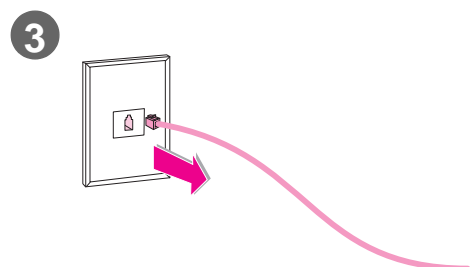
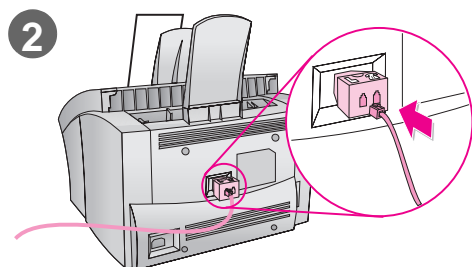
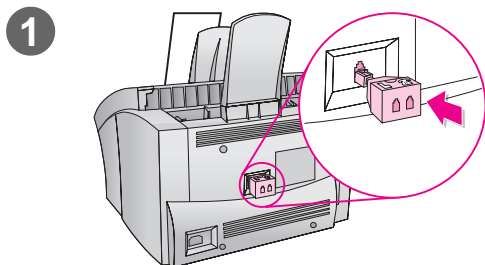

## Connecting the HP LaserJet 3150 product and other devices

Use this procedure if you are connecting the HP LaserJet 3150 product and other devices to this wall socket.

### Note

If you do not have an RJ11 socket or an RJ11 adaptor did not come with the HP LaserJet 3150 product, you must buy and install an adaptor to convert the wall socket to an RJ11 socket.

## To connect the HP LaserJet 3150 product

- 1 Plug the included modular double adaptor into the back of the HP LaserJet 3150 product.
- 2 Plug one end of the included telephone cord into the side of the modular double adaptor marked with an L or the word "Line."
- 3 If a telephone cord is plugged into the wall socket, unplug it and set it aside.
- 4 Plug the other end of the product cord into the wall socket.

### ✓ Check your work

Go to "Connecting other devices to the phone line" on page 25.



## Connecting other devices to the phone line

In this section, you will decide what (if any) other devices to connect to the same phone line as the HP LaserJet 3150 product and then connect those devices.

### Deciding what else to connect

In the previous step, you connected the HP LaserJet 3150 product to a wall socket for the phone line. Generally, there are only three other devices you might want or need to connect to the same phone line:

- a telephone
- an answering machine
- an external modem *or* a computer with an internal modem.

Which, if any, of these you connect to this phone line depends on your situation, which should be one of the following two situations.

#### **If you have a computer modem**

If you have an internal computer modem or an external modem please note that the HP LaserJet 3150 product **cannot** be used as a data modem to communicate with other computers, to send and receive e-mail, or to connect to the Internet. You must keep the computer modem connected to a phone line for these purposes.

---

## **Situation 1: You connected the HP LaserJet 3150 product to a wall socket with a phone line for fax calls only (a dedicated fax line).**

You do not need to connect any other devices. However:

- You can connect your external modem or computer with internal modem to this same phone line if you want to use the fax line to access the Internet or e-mail.
- You can connect an extra telephone to this wall socket if you would like to make *outgoing* voice calls on this phone line.

To connect these devices to the same wall socket as the HP LaserJet 3150 product, go to “Connecting other devices, overview” on page 27.

If you have another wall socket for this phone line, you can connect the extra phone and/or external modem or computer with internal modem to the other socket.

---

### **Note**

*Because this is a dedicated fax line, you should never have an answering machine or computer voicemail connected to it.*

If you are using computer voicemail, you *must* connect the computer with internal modem or the external modem to your dedicated *voice* line. You will connect to the Internet or e-mail using the dedicated voice line.

---

## **Situation 2: You connected the HP LaserJet 3150 product to a wall socket with a phone line for fax and voice calls (a shared line).**

Connect any other devices you have to this phone line. To connect the other devices you have to the same wall socket as the product, go to “Connecting other devices, overview” on page 27.

If you have another wall socket for this phone line, you can connect some of the devices to that socket. However, if you have an answering machine or computer with voicemail, make sure to connect it to the same socket as the HP LaserJet 3150 product.

### **Special situation (only for Australia)**

**You have one phone line with two phone numbers and distinctive ring service.**

Use the same guidelines in **Situation 2** above for connecting other devices. You will change settings for distinctive ring later in the setup.

## Connecting other devices, overview

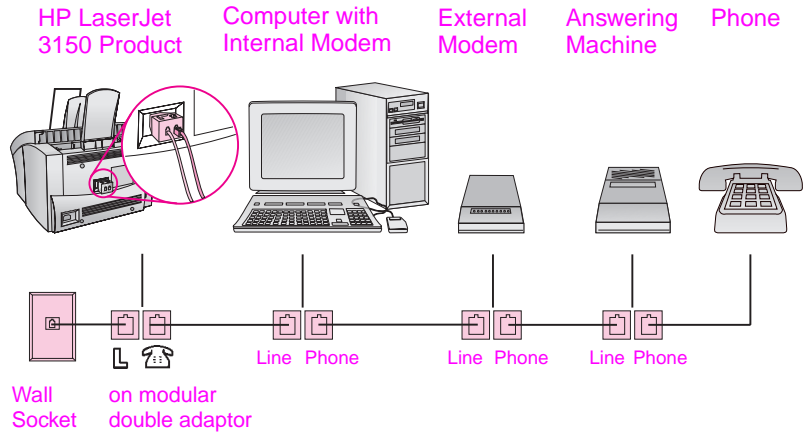

If you are not connecting one (or more) of the devices shown, just cross it out. Then, in the order indicated, you will connect the devices you do have to the HP LaserJet 3150 product. See “a. Preparing the product and other devices” on page 28 to begin step-by-step instructions.

Keep in mind these important points:

- The HP LaserJet 3150 product *must* be the device connected into the wall socket. If it isn't, it cannot answer incoming fax calls.
- As the drawing indicates, always plug between the “Line” jack on one device and the “Phone” jack on another device.
- Some computers have a second “Line” jack which is used to connect the computer to a dedicated *voice* line. If you have a second “Line” jack, check your computer's documentation to ensure you are connecting to the correct “Line” jack.

## a. Preparing the product and other devices

- 1 Unplug all devices from their power source.
- 2 Go to "b. Connecting a computer with an internal modem."

## b. Connecting a computer with an internal modem

Did you decide to connect a computer with an internal modem to the same phone line as the HP LaserJet 3150 product?

- No.** Go to "c. Connecting an external modem" on page 29.
- Yes.** Plug the computer's cord into the "Phone" jack on the HP LaserJet 3150 product.

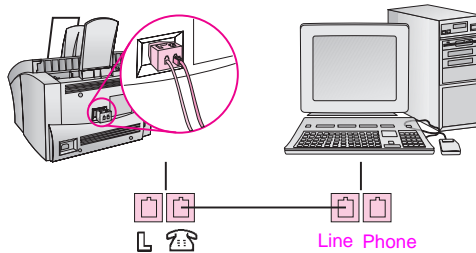

### c. Connecting an external modem

Did you decide to connect an external modem to the same line as the HP LaserJet 3150 product?

- No.** Go to "d. Connecting an answering machine."
- Yes.** Plug the external modem's cord to the "Phone" jack on the HP LaserJet 3150 product (or on the computer with internal modem).

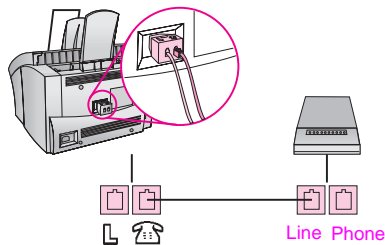

### d. Connecting an answering machine

Did you decide to connect an answering machine to the same phone line as the HP LaserJet 3150 product?

- No.** Go to "e. Connecting a telephone" on page 30.
- Yes.** Plug the answering machine's cord into the "Phone" jack on the HP LaserJet 3150 product or the last device you connected.

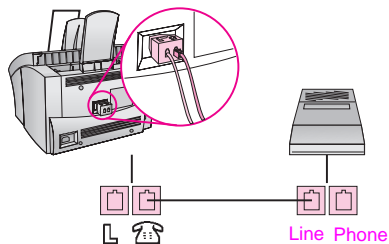

## e. Connecting a telephone

Did you decide to connect a telephone to the same line as the HP LaserJet 3150 product?

- No.** Go to "f. Reconnecting to the power source" below.
- Yes.** Plug the telephone's cord into the "Phone" jack on the HP LaserJet 3150 product or the last device you connected.

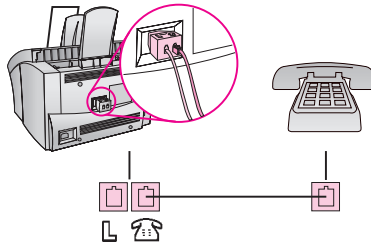

## f. Reconnecting to the power source

Plug all devices back into their power source.

### Check your work

After ensuring that all phone cords are securely connected, go to "Connecting the product power cord" on page 31.





## Connecting the product power cord

1

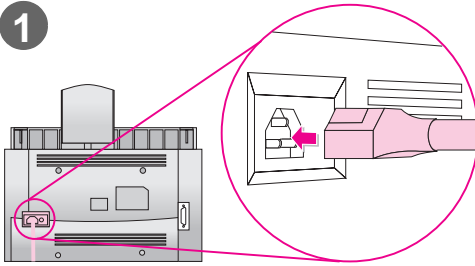

The HP LaserJet 3150 product does not have a power switch. It turns on when the power cord is connected.

---

### CAUTION!

HP does not recommend using battery backup or uninterruptible power supplies with this product. Using them could damage the product.

---

### To connect the product power cord

- 1 Connect the power cord to the connector on the back of the HP LaserJet 3150 product.
- 2 Plug the other end into a grounded power strip or wall outlet. Once the power is connected, the product turns on and runs an internal self-test.

---

### Note

---

If you have plugged the product into a power strip, keep the power strip turned on at all times. Otherwise, the product cannot receive faxes.

---

## Check your work

Does the control panel display say: Use MENU or Software to Set Fax Header or Ready?

**Yes.** Go to “Testing the hardware” on page 33.

**No.** Do the following:

- Unplug the power cord from the power source and the product. Then, replug it in.
- If you plugged the power cord into a surge protector, unplug the power cord and plug it directly into a working wall outlet.
- If you received the message Self Test: No Dial Tone, unplug the HP LaserJet 3150 product's *phone* cord from the wall and the product and then replug it in. Then, press and hold **STOP/CLEAR** for seven seconds so the product will check again for a dial tone.

If this still does not produce a dial tone, plug the product phone cord into another wall jack and test again, plug a telephone into the wall jack and try to make an outgoing call, or try using a different phone cord. This ensures that the wall jack and phone cord are working.

When you do see Use MENU or Software to Set Fax Header or Ready, go to “Testing the hardware” on page 33.

## Testing the hardware

After plugging in the power cord, you should be able to print the demonstration page and make a copy of it. This test ensures that the hardware is working properly.

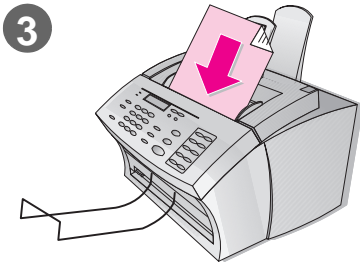
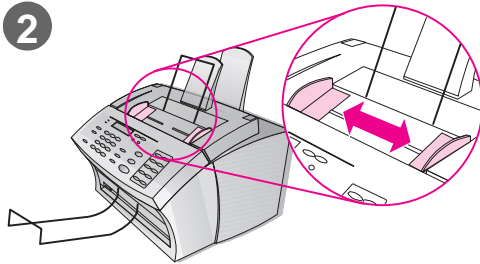

### To test the hardware

- 1 At the product control panel, press **VOLUME+CONTRAST** simultaneously. The demonstration page prints.
- 2 Adjust the guides in the document feeder tray to the size of the page.
- 3 Place the page top first, face down, into the document feeder tray. Wait for the HP LaserJet 3150 product to load it.
- 4 Press **COPY**.

The HP LaserJet 3150 product makes one copy and returns to the **READY** state.

### Check your work

Were you able to print and copy the demonstration page?

- Yes.** Great! You have finished the hardware installation. Save the demonstration page for use later in the setup, and go to “Finishing the installation” on page 34.
- No.** Try printing and copying the page again, making sure to press **COPY** (not **START**, which would try to send the page as a fax).

Once you have printed and copied the demonstration page, go to “Finishing the installation” on page 34.

---

# 2 Finishing the installation

In this section, you will connect the product directly to a computer using a parallel cable, connect the product to the network using a HP JetDirect print server, or not to connect the product at all (standalone). If you can connect the product to a computer or network, HP strongly recommends doing so and installing the software. This gives you the maximum product functionality.

## Check your work

Choose one of the following installations:

- I am connecting the product directly to a computer using a parallel cable.** See “Option A: Connecting directly to a computer” on page 35.
- I am connecting the product to the network using an HP JetDirect print server.** See “Option B: Connecting to a network” on page 42.
- I am not connecting the product to a computer or network.** See “Option C: Completing a standalone installation” on page 46.



## Option A: Connecting directly to a computer

In this section, you will do the following:

- Connect the product to a computer using a parallel cable.
- Install the software.
- If you want, share the product with other network users so they can print to it. Note that sharing the product may slow down your computer while other users are printing to the product.

*See the pages that follow for step-by-step instructions.*

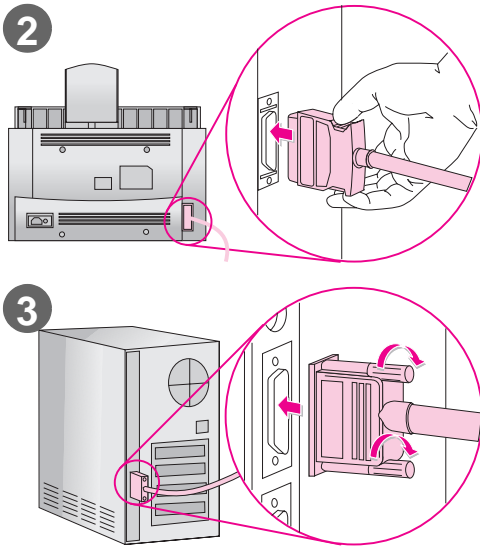

## Connecting to a computer

Use this procedure to connect the product to a computer using a parallel cable.

---

### Important!

The HP LaserJet 3150 product should be connected directly to a dedicated parallel port on the computer. See “Checking computer or network requirements” on page 12 for more information.

---

### To connect the product to a computer

- 1 Turn off the computer.
- 2 Squeeze the clips on the sides of the parallel cable and attach it to the connector on the back of the HP LaserJet 3150 product. Gently tug on the cable to ensure it is securely connected, and then push it back in.
- 3 Connect the other end of the cable to a parallel port on the computer. Secure the cable by tightening the screws.
- 4 Turn the computer on again.

---

### CAUTION!

Do not connect the parallel cable to a serial port on the computer. Doing so can damage the HP LaserJet 3150 product. If you need help locating the parallel port, see the documentation for the computer.

---

### Check your work

Go to “Preparing for software installation” on page 37.

---

## Preparing for software installation

This section contains instructions for installing the HP LaserJet 3150 software on a computer running Windows 3.1x, 9x, NT 4.0, or 2000 when the HP LaserJet 3150 product is directly connected to a computer. You will also set required fax settings during the installation.

When you install software, you will be asked if you want an Express or a Custom installation. The Express installation installs all of the software and is recommended for first-time users. If you choose the Express installation, the following items install:

- Installer software – installs all software.
- Configuration software – helps you configure and set up the HP LaserJet 3150 product.
- Driver software – allows you to print from your computer to the HP LaserJet 3150 product and scan from the HP LaserJet 3150 product to the computer.
- PC Fax software – allows you to send faxes from and receive faxes to your computer.
- Document Assistant software – allows you to use the software to fax, copy, scan, or e-mail a *paper* document.
- The JetSuite™ Pro software for Hewlett-Packard – allows you to print, fax, copy, and scan from your computer. Also lets you annotate, organize, and store scanned items.
- Optical character recognition (OCR) software – used to convert scanned images into text that can be edited in word-processing software.
- Software Help – provides help for using the software.
- Product registration – provides an easy way for you to register the product so you can be notified about software and firmware updates as they become available.

---

## **If you already have a PC fax program**

The JetSuite software that came with the HP LaserJet 3150 product includes a PC fax program. HP recommends using the included JetSuite PC fax program because it is designed to work with the HP LaserJet 3150 product, but you can continue using the PC fax program you already have. The only requirement is that you must choose one of the PC fax programs to answer incoming fax calls: both programs cannot try to answer fax calls coming to the same line.

Do one of the following:

- To use the JetSuite PC fax program, change the setup for your other PC fax program so that the other program doesn't answer incoming calls. Or, uninstall the other program.
- To continue using your PC fax program, see the Readme.txt file for a list of PC fax packages that have been tested for compatibility with the HP LaserJet 3150 product.

## **If you already have scanning software**

The HP LaserJet 3150 product comes with scanning software. You can use it or any other TWAIN-compliant scanning software that is compatible with the product. See the Readme.txt file for a list of programs that have been tested for compatibility.



---

## a. Installing the software for a directly connected computer

Follow the installation instructions for your operating system.

### To install software on Windows 9x, NT 4.0, or 2000

---

#### Note

---

To install the software on Windows NT 4.0 or 2000, you must have administrator privileges (on start and restart).

- 1 If the “New Hardware Found” screen has opened, click **Cancel**.
- 2 Quit all open programs using the **Close Programs** or **Task Manager** dialog box.
- 3 Insert the CD-ROM into the CD-ROM drive (usually D). When the welcome screen opens, follow the directions on screen. (If the welcome screen does not open, click **Start**, and then **Run**. Type `X:SETUP`, replacing “X” with the letter of your drive, and click **OK**.)
- 4 Follow the instructions on the screen. The setup takes a few minutes. When it is complete, remove the CD-ROM and store it in the pocket on the inside front cover of this getting started guide.

### To install the software on Windows 3.1x

- 1 Quit all open programs **except** Program Manager:
- 2 Insert the CD-ROM into the CD-ROM drive (usually D).
- 3 From the **File** menu in Program Manager, choose **Run**.
- 4 Type `X:SETUP`, replacing “X” with the letter of your drive, and click **OK**.

---

#### Note

---

Windows-32 Bit extensions (Win32s) are required. If prompted to install Win32s and Freecell, click **OK** and **Continue** to install these programs.

- 5 Follow the instructions on the screen. The setup takes a few minutes. When it is complete, remove the CD-ROM and store it in the pocket on the inside of the front cover.

## b. Printing a document as a test

Print an electronic document to ensure that the HP LaserJet 3150 product and software are working properly.

### To print a document as a test

- 1 Open a document created in a program such as Wordpad or Write.
- 2 On the **File** menu, select the **Print** command. Make sure the HP LaserJet 3150 product is selected and click **OK**.

### Check your work

Did the document print?

- Yes.** Great! You have finished installing the software and setting the required settings. If you want to share the product with other network users so they can print to the product, go to “Sharing the product” on page 41. Otherwise, go to “Exploring the product and software” on page 60 to begin a fast and easy tutorial to learn how to use the product and software.
- No.** Do the following:
  - Go to “Troubleshooting” on page 55 to check for messages and solutions to common installation issues.
  - If the troubleshooting section does not resolve the issue, see “HP Customer Care” on page 58.

Once you resolve the problem, go to “Sharing the product” on page 41. Otherwise, go to “Exploring the product and software” on page 60 to begin a fast and easy tutorial to learn how to use the product and software.

---

## Sharing the product

Using Windows sharing, the person using the computer directly connected to the HP LaserJet 3150 product can allow other users on the network to print to it. Computers running Windows 3.11 can use Windows sharing to print, but the computer directly connected to the product must be running Windows 9x, NT 4.0, or 2000. Also note that because printing using Windows sharing is unidirectional, network users do not receive printer status messages when they print to the product.

See the computer documentation to enable Windows sharing. Once the product is shared, install the printer drivers on all computers you want to allow to print to the product. For Windows 9x, NT 4.0, or 2000, the easiest way to do this is to use the following procedure, which does not require the CD-ROM. For Windows 3.1x, see the documentation for your computer to install printer drivers.

### To add the printer driver to network computers for 9x, NT 4.0, and 2000

- 1 On the **Start** menu, point to **Settings**, and click **Printers**.
- 2 Double-click **Add Printer** and click **Next**.
- 3 Follow the directions on screen. Also:
  - When asked if the product is a local or network printer, select **Network Printer**.
  - To find the printer, click **Browse**, locate the printer name, and click **OK**.
  - When prompted, print a test page to ensure the printer driver is installed properly.

### Check your work

When you are ready, go to “Exploring the product and software” on page 60 to begin a fast and easy tutorial to learn how to use the product and software.



## Option B: Connecting to a network

To connect the product to the network using an HP JetDirect print server, you need to do the following.

- a Purchase and install a supported HP JetDirect print server or check that the one you have is supported. (See page 13 for a list of supported print servers. See the documentation for the print server to install it.)
- b Test the hardware installation by printing a configuration page for the HP JetDirect print server. To do this, press **Test** on the print server. (*If the page does not print, use ASCII as the printer language.* See the documentation for the print server for further instructions.)
- c Check the model or firmware revision number, which is located in the first section of the configuration page you just printed.
  - If you have a 170X print server and the model number is *not* J3258B, you must get a new print server.
  - If you have a 300X or 500X print server and the firmware revision number is *not* H.08.00 or J.08.00 or higher, you must upgrade firmware before proceeding. (See “Upgrading firmware” below.)
- d Connect the HP LaserJet 3150 product to the print server. (See the documentation for the print server.)
- e **Important!** Unplug the power cord for the HP LaserJet 3150 product and replug it in. Otherwise, the product does not detect that it is on a network and will not work correctly.
- f Install the JetSuite™ Pro software for Hewlett-Packard on all computers that want to use it. (See “Preparing for software installation” on page 43.)

### Upgrading firmware

If you have a 300X or 500X print server and the firmware revision is not H.08.00 or J.08.00 or higher, you can download a firmware upgrade from the HP website at [http://www.hp.com/support/net\\_printing](http://www.hp.com/support/net_printing). Or, see the documentation that came with the HP JetDirect print server.

---

## Preparing for software installation

This section contains instructions for installing the HP LaserJet 3150 software. When you install the user software, you will be asked if you want an Express or a Custom installation. The Express installation installs all of the software and is recommended for first-time users. If you choose the Express installation, the following items install:

- Installer software – installs all software.
- Configuration software – helps you configure and set up the HP LaserJet 3150 product.
- Driver software – allows you to print from your computer to the HP LaserJet 3150 product and scan from the HP LaserJet 3150 product to the computer.
- PC Fax software – allows you to send faxes from your computer.
- The JetSuite Pro software – allows you to print, send faxes, and scan from your computer. Also lets you annotate, organize, and store scanned items.
- Optical character recognition (OCR) software – used to convert scanned images into text that can be edited in word-processing software.
- Software Help – provides help for using the software.
- Product registration – provides an easy way for you to register the product so you can be notified about software and firmware updates as they become available.

### If you already have a PC fax program

The JetSuite software that came with the HP LaserJet 3150 product includes a PC fax program. In a network installation, you must use this PC fax program to send faxes through the product.

### If you already have scanning software

The HP LaserJet 3150 product comes with scanning software. You can use it or any other TWAIN-compliant scanning software that is compatible with the product. (TWAIN is an industry standard.) See the Readme.txt file for a list of programs that have been tested for compatibility.

## a. Installing software for network computers

Use this procedure to do any network configuration and install software on network computers. In order to install the software, the computers must be running Windows 9x, NT 4.0, or 2000.

**For IPX/SPX users:** You must use the IPX/SPX protocol in Direct mode.

**For TCP/IP users:** It is not necessary to create a TCP/IP printing services port on client computers. The HP LaserJet 3150 product does not use this type of port.

**Important!** The HP LaserJet 3150 product may be assigned to the LPT1 port at installation. Do *not* redirect the product from the default installed port to another port, such as an HP JetDirect port, or the product will not work correctly.

### To install software

---

#### Note

---

To install the software on Windows NT 4.0 or 2000, you must have administrator privileges (on start and restart).

- 1 Quit all open programs using the **Close Programs or Task Manager** dialog box.
- 2 Insert the CD-ROM into the CD-ROM drive (usually D or E). When the welcome screen opens, follow the directions on screen. (If the welcome screen does not open, click **Start**, and then **Run**. Type `x:SETUP`, replacing "x" with the letter of your drive, and click **OK**.)
- 3 Follow the instructions on the screen.  
**Important!** Only one person should set the fax settings. When you reach the fax set up portion of the installation, choose **Skip** if you know someone else set the fax settings, or if the control panel display on the product says `READY`.
- 4 Remove the CD-ROM when the setup is finished.
- 5 Repeat steps 1-4 for all other computers on which you want to install software.
- 6 When finished, store the CD-ROM in the pocket on the inside of the front cover of this getting started guide.

---

## b. Printing a document as a test

Print an electronic document to ensure that you can use the software you installed to print to HP LaserJet 3150 product.

### To print a document as a test

- 1 Open a document created in a program such as Word or Wordpad.
- 2 On the **File** menu, select the **Print** command. Make sure the HP LaserJet 3150 product is selected and click **OK**.

### Check your work

Did the document print?

- Yes.** Great! The product is now ready to work on the network. Go to “Exploring the product and software” on page 60 to begin a fast and easy tutorial to learn how to use the product and software.
- No.** Do the following:
  - Go to “Troubleshooting” on page 55 to check for solutions to messages and common installation issues.
  - If the troubleshooting section does not resolve the issue, see “HP Customer Care” on page 58.



## Option C: Completing a standalone installation

Certain settings must be determined before using the HP LaserJet 3150 product as a standalone fax machine. If you have installed the software, you already set these features, and you can go “Exploring the product and software” on page 60.

If you do not intend to install the software now, you need to do the following (described in greater detail on the next few pages):

- a Set the correct time and date.
- b Enter the fax header information. *Filling it in is a legal requirement.* Most HP LaserJet 3150 product functions are not available until it is filled in.
- c Check the answer mode and number of rings-to-answer settings. Depending on your configuration, you may or may not have to alter these settings.
- d If you live in Australia and have distinctive ring service from your local telephone company, you need to enable distinctive ring detection. *The product only supports distinctive ring in Australia.*
- e Print a self-test report to ensure the product is working properly.

### Check your work

Go to “a. Setting the time and date” on page 47 to begin checking and changing these settings.

### To learn more

For information on changing other settings, such as adjusting the speaker volume or programming a key to store a special dialing code, see chapter 7, “Managing Basic Features,” in the user guide.



## a. Setting the time and date

The time and date information is included in the header that prints at the top of faxes you send. The time and date also show on the control panel display when the HP LaserJet 3150 product is idle.

### To set the time and date

- 1 Press **ENTER/MENU**.
- 2 Use the **<** and **>** keys to select **TIME/DATE: HEADER** and press **ENTER/MENU**.
- 3 Press **ENTER/MENU** to select **TIME/DATE**.
- 4 Use the **<** and **>** keys to select a 12-hour or 24-hour clock and press **ENTER/MENU**.
- 5 Enter the current time using the numeric keys.
- 6 If you chose the 24-hour clock, press **ENTER/MENU**.  
- Or -  
If you need to change the AM or PM designation, use the **<** and **>** keys to select the correct one, and then press **ENTER/MENU**.
- 7 Enter the current date using the numeric keys. Make sure to enter the month and day using both digits, such as "05" for May.

---

#### Note

---

If you enter a number incorrectly, press **BACK SPACE** until you reach the entry. Then re-enter the number.

- 8 Press **ENTER/MENU**.
- 9 Press **STOP/CLEAR** to exit the Menu settings.

### Check your work

Go to "b. Setting the fax header" on page 48.

---

## b. Setting the fax header

This information prints at the top of faxes you send. *Filling it in is a legal requirement.* Most HP LaserJet 3150 product functions are not available until it is filled in.

---

### Note

To use special dialing symbols, see chapter 7, “Managing Basic Features,” in the user guide.

### To set the fax header

- 1 Press **ENTER/MENU**.
- 2 Use the **<** and **>** keys to select **TIME/DATE**, **HEADER** and press **ENTER/MENU**.
- 3 Use the **<** and **>** keys to select **FAX HEADER** and press **ENTER/MENU**.
- 4 Enter your fax number and press **ENTER/MENU**. To separate numbers, press **>** to insert spaces. To add a plus sign, press **\***.
- 5 Use the numeric keys to add the name of your company (32 characters maximum). To do so, repeatedly press the numeric key for the letter you need until the letter appears. (For example, if the first letter you need is a “C,” press **2** repeatedly until a **C** appears.) Press **>** to go to the next space.

---

### Note

To insert punctuation, press **\*** repeatedly until the character you want appears, and then press **>** to go to the next space.  
To delete a letter, press **<** or **>** until you reach the space to the right of the letter, and then press **BACK SPACE**.

- 6 When you have finished, press **ENTER/MENU**.
- 7 Press **STOP/CLEAR** to exit the Menu settings.

---

## Check your work

Does the control panel display say `READY AUTO`, followed by the date and time you set?

**Yes.** Go to “c. Setting answer mode and rings to answer” on page 50.

**No.** Do the following:

- If the control panel display does not say `READY AUTO`, repeat step b.
- If the control panel display does not show the correct time and date, repeat step a to change them.

When you are ready, go to “c. Setting answer mode and rings to answer” on page 50.

## c. Setting answer mode and rings to answer

The answer mode is set to Automatic or Manual depending on your situation. In Automatic mode, the HP LaserJet 3150 product answers incoming calls after the number of rings to answer specified. Or, it “listens” for fax tones when an answering machine connected to the line answers first and then answers if it is a fax call. In Manual mode, the HP LaserJet 3150 product never answers calls. You must start the fax receiving process yourself, either by pressing **START** on the control panel or by picking up a phone connected to that line (and possibly pressing **\*\*\***).

If the HP LaserJet 3150 product is set to Automatic mode, you may need to adjust the rings-to-answer setting. This is especially important if the HP LaserJet 3150 product is connected to a line receiving both fax and voice calls (a shared line) with an answering machine. The rings to answer on the HP LaserJet 3150 product must be higher than the rings to answer on the answering machine. This allows the answering machine to answer the incoming call and record a message if it is a voice call. This also allows the HP LaserJet 3150 product to listen to the call, and if it detects fax tones, to take the call.

For the HP LaserJet 3150 product, the factory default answer mode is Automatic. The default number of rings to answer is 1 in Malaysia and Singapore and 5 in all other countries. Use the table below to determine what settings to use given your situation.

If you have:	Do this with the answer mode:	And do this with the number of rings to answer on the HP LaserJet 3150 product:
A line only receiving fax calls (a dedicated line).	Leave set to Automatic.	Australia: Change to 2 or 3 rings. Malaysia and Singapore: Leave at 1 or change to 2. All others: Change to 1 or 2 rings.
A line receiving both fax and voice calls (a shared line) and only a telephone.	Leave set to Automatic*.	Malaysia and Singapore: Set to 5. All others: Leave at 5.
A line receiving both fax and voice calls (a shared line) and an answering machine or computer voicemail.	Leave set to Automatic.	All: Set to 2 higher than answering machine or computer voicemail. For example, set to 6 if answering machine answers at 4. <i>Set the HP LaserJet 3150 product no higher than 9.</i>
One line with distinctive ring service (two separate phone numbers) (POSSIBLE IN AUSTRALIANEW ZEALAND ONLY).	Leave set to Automatic	Change to 1 or 2 rings. (If you have an answering machine or computer voicemail for the other phone number, make sure the product is set <i>lower</i> than the answering system.) Also see “d. Enabling distinctive ring detection” on page 52.

\*In Automatic, the HP LaserJet 3150 product automatically answers fax calls. However, people calling to speak to you hear fax tones if you do not answer or they do not hang up by the number of rings at which the product answers. Use Manual if you do not want voice callers ever to hear fax tones, but remember that fax calls are not received automatically.

## To set the answer mode

- 1 Press **ENTER/MENU**.
- 2 Use the **<** and **>** keys to select **FAX SETTINGS** and press **ENTER/MENU**.
- 3 Use the **<** and **>** keys to select **INCOMING FAXES** and press **ENTER/MENU**.
- 4 Press **ENTER/MENU** to select **ANSWER MODE**.
- 5 Use the **<** and **>** keys to select **AUTOMATIC** or **MANUAL** and press **ENTER/MENU**.
- 6 Press **STOP/CLEAR** to exit the Menu settings.

## To set the number of rings to answer

- 1 Press **ENTER/MENU**.
- 2 Use the **<** and **>** keys to select **FAX SETTINGS** and press **ENTER/MENU**.
- 3 Use the **<** and **>** keys to select **INCOMING FAXES** and press **ENTER/MENU**.
- 4 Use the **<** and **>** keys to select to select **RINGS TO ANSWER** and press **ENTER/MENU**.
- 5 Enter the number of rings to answer and press **ENTER/MENU**.
- 6 Press **STOP/CLEAR** to exit the Menu settings.

### Check your work

Does the upper right corner of the display show the answer mode setting (Automatic or Manual) that you chose?

- Yes.** If you have distinctive ring service, go to “d. Enabling distinctive ring detection” on page 52. Otherwise, go to “e. Printing a self-test report” on page 54.

- No.** Do the following:

Try setting the answer mode again. When you are ready, go to “d. Enabling distinctive ring detection” on page 52 (if you have distinctive ring service) or “e. Printing a self-test report” on page 54.

---

## d. Enabling distinctive ring detection

This procedure only applies to Australia. If you subscribe to distinctive ring service with your telephone company, use this procedure to enable the HP LaserJet 3150 product to detect distinctive ring patterns. *If you do not have distinctive ring service, do not change this setting, or the HP LaserJet 3150 product will not be able to receive faxes.*

### What is distinctive ring service?

Distinctive ring service is available from some local telephone companies. It allows you to have two or three phone numbers on one line. This costs less than paying for two or three separate lines. Each of the phone numbers will have a different ring pattern. In Australia, calls to the voice number ring with a double-ring pattern, and calls to the fax number ring with a triple-ring pattern. These distinctive ring patterns allow you to answer the call if it is a voice call and allow the product to answer if it is a fax call.

### How do I get it?

If you would like distinctive ring service, call your local telephone company to check availability and to subscribe. The service is called "FaxStream" in Australia. As of this printing, the service is only available in some areas.

If distinctive ring is available and you choose to subscribe to it, keep the following points in mind:

- Make sure the telephone company assigns the triple-ring pattern to the fax number. The HP LaserJet 3150 product ignores the others.
- While distinctive ring service may allow you to have up to three phone numbers on the same line, the HP LaserJet 3150 product only supports two numbers. The HP LaserJet 3150 product cannot detect the difference between the second and third ring patterns and would answer calls coming to both the second and third numbers.

## To enable distinctive ring detection

### Note

Only change this setting to Yes if you have distinctive ring service from your telephone company. *If you do not have distinctive ring service, do not change this setting or the HP LaserJet 3150 product will not be able to receive faxes.*

- 1 Call your local telephone company and subscribe to distinctive ring service.
- 2 Press **ENTER/MENU**.
- 3 Use the **<** and **>** keys to select **FAX SETTINGS** and press **ENTER/MENU**.
- 4 Use the **<** and **>** keys to select **INCOMING FAXES** and press **ENTER/MENU**.
- 5 Use the **<** and **>** keys to select **DISTINCTIVE RING** and press **ENTER/MENU**.
- 6 Use the **<** and **>** keys to select **YES** or **NO** and press **ENTER/MENU**.
- 7 Press **STOP/CLEAR** to exit the Menu settings.

### If you have an answering machine or computer voicemail on this line for the other phone number

Make sure the HP LaserJet 3150 product's rings to answer is set to a *lower* number than the rings to answer on the answering machine or voicemail. In the case of distinctive ring, the HP LaserJet 3150 product must answer calls first in order to be able to receive fax calls.

### Check your work

Does the control panel display say **DISTINCT** in the upper right corner?

- Yes.** Go to “e. Printing a self-test report” on page 54.
- No.** Repeat this step to try enabling distinctive ring. When you are ready, go to “e. Printing a self-test report” on page 54.

---

## e. Printing a self-test report

Print a self-test report from the product to ensure that the product is working correctly.

### To print a self-test report

- 1 Press **ENTER/MENU**.
- 2 Use the **<** and **>** keys to select **REPORTS** and press **ENTER/MENU**.
- 3 Use the **<** and **>** keys to select **SELF TEST** and press **ENTER/MENU**.

The HP LaserJet 3150 product exits the Menu settings and prints the report, which confirms the HP LaserJet 3150 product is working.

### Check your work

Check the report. In the Self Test Results section, do all tests have a **PASS** entry?

- Yes.** Great! You have finished setting the required settings. Go to “Exploring the product and software” on page 60 to begin a fast and easy tutorial on how to use the product.
- No.** See “HP Customer Care” on page 58.



# Troubleshooting

Use the following table to solve problems that might occur when installing the software or changing settings manually.

Problem	Cause	Solution
When installing software, you receive this message: "Setup has determined that you do not have enough disk space on the selected drive. Please reduce the set of install components or change the install drive."	The JetSuite software requires at least 65 MB of available disk space to be installed.	After you select the JetSuite software and data directories, the installation program checks that your computer has enough available disk space. Try deleting unnecessary files or archiving older data to floppy disks or some other medium.
The software did not install (Windows 9x, NT 4.0, or 2000)	All programs <i>except</i> Systray and Explorer should be closed.	To check in Windows 9x, press <b>CTRL+ALT+DELETE</b> . If other programs are open, click one and click <b>End Task</b> . Repeat for all other open programs. Then, reinstall the software. To check in Windows NT 4.0 or 2000, press <b>CTRL+ALT+DELETE</b> . On the <b>Applications</b> tab, if other programs are open, click one and click <b>End Task</b> . Repeat for all other open programs. Then, reinstall the software.
The computer cannot read the installation CD-ROM.	The correct drive may not have been specified.  The CD-ROM may be damaged.	Check for the proper disk drive letter. Often, it is <b>D</b> or <b>E</b> for the CD-ROM drive.  Contact HP Customer Care. See page 58.
You receive this message "There are not enough free COM ports on this system. You must have at least one available COM port to install this software."	The software needs at least one COM port. At least one COM port is not available.	See the documentation for your computer to free a COM port.

<b>Problem</b>	<b>Cause</b>	<b>Solution</b>
<p>When the product is directly connected to your computer, you receive this message: "JetSuite Fax has detected that the HP LaserJet 3150 is either switched off or is not connected to your computer."</p>	The parallel cable is loose or not directly connected.	Make sure the parallel cable between the computer and the HP LaserJet 3150 product is securely connected.
	The power cord is loose.	Make sure the power cord is securely connected between the HP LaserJet 3150 product and the power source.
	The parallel cable may be faulty.	If you have another "size C" parallel cable, try attaching it to the HP LaserJet 3150 product.
	The BIOS setting for your computer may not be set correctly.	Ensure that the computer has a parallel port with a bidirectional data bus. (EPP or unidirectional ports are not supported.) Change the parallel port mode setting in the computer's BIOS. HP recommends setting it to ECP or bidirectional, but other modes may also work. For instructions on changing the setting, see Appendix C in the user guide, see the computer documentation, or contact the computer manufacturer.
<p>When the product is connected to the network using an HP JetDirect print server, you receive this message: "JetSuite Fax has detected that the HP LaserJet 3150 is either switched off or is not connected to your computer."</p>	The power cord is loose.	Make sure the power cord is securely connected between the HP LaserJet 3150 product and the power source. Also, ensure the power cord for the HP JetDirect print server is securely connected to the power source.
	The network cord is loose.	Ensure the network cable is securely connect between the HP JetDirect print server and the wall outlet for the network. Also ensure the network cable between the computer and the wall is securely connected.
	The parallel cable is loose or not directly connected.	Make sure the parallel cable between the HP JetDirect print server and the HP LaserJet 3150 product is securely connected.
	The parallel cable may be faulty.	If you have another "size C" parallel cable, try connecting it between the HP LaserJet 3150 product and the HP JetDirect print server.
	The HP JetDirect print server may not be configured yet (TCP/IP).	Use the HP JetAdmin software, the HP WebJet Admin software, BOOTP, DHCP, or telnet to configure the HP JetDirect print server.
HP JetDirect print server is incorrectly configured (TCP/IP).	See the documentation that came with the HP JetDirect print server for troubleshooting information.	

Problem	Cause	Solution
When the product is connected to the network using an HP JetDirect print server, you receive this message: "All in One configuration cannot continue because the required protocols were not found on your computer."	The IPX/SPX or TCP/IP protocols are not installed on your computer.	Install an IPX/SPX protocol that is compatible with NW Link or a TCP/IP protocol on your computer.
When the product is connected to the network using an HP JetDirect print server, you receive one of these messages: <ul style="list-style-type: none"> <li>• "The configuration wizard did not find your HP LaserJet 3150 All in One on the network."</li> <li>• "The configuration wizard was unable to find an All in One at the specified address."</li> <li>• "The JetDirect model found at the specified address does not support All in One devices."</li> </ul>	<p>The print server you are using is not one of the HP JetDirect print servers that works with the product.</p> <p>The power cord is loose.</p> <p>The network cord is loose.</p> <p>The parallel cable is loose or not directly connected.</p> <p>The parallel cable may be faulty.</p> <p>The HP JetDirect print server may not be configured yet (TCP/IP).</p> <p>HP JetDirect print server is incorrectly configured (TCP/IP).</p>	<p>See "Connecting to a network using an HP JetDirect print server" on page 12 for a list of compatible HP JetDirect print servers.</p> <p>Make sure the power cord is securely connected between the HP LaserJet 3150 product and the power source. Also, ensure the power cord for the HP JetDirect print server is securely connected to the power source.</p> <p>Ensure the network cable is securely connect between the HP JetDirect print server and the wall outlet for the network. Also ensure the network cable between the computer and the wall is securely connected.</p> <p>Make sure the parallel cable between the HP JetDirect print server and the HP LaserJet 3150 product is securely connected.</p> <p>If you have another "size C" parallel cable, try connecting it between the HP LaserJet 3150 product and the HP JetDirect print server.</p> <p>If you installed the HP LaserJet 3150 software, uninstall it. Then, re-install the software and select the Network Install option.</p> <p>See the documentation that came with the HP JetDirect print server for troubleshooting information.</p>

---

# HP CUSTOMER CARE



## Online

Connect with HP! Whether you are a beginner or advanced user, HP Customer Care online is a great place to learn more about your product. Click your way to the answers, training, and software updates you need, 24 hours a day, 7 days a week, all at no charge to you. Visit <http://www.hp.com/support/lj3150>. (Site is in English.)



## E-mail

Get assistance conveniently and quickly with e-mail. E-mail your question to HP, and you will receive a reply within 24 hours on business days. It's that simple. E-mail questions via HP's website at <http://www.hp.com/support/lj3150>. (Site is in English.)



## User forums

Go online, anytime, to find other users with great ideas and usage suggestions at HP's online user forum for the HP LaserJet 3150 product. Visit HP's website at <http://www.hp.com/support/lj3150>. (Site is in English.)

---

Your purchase is backed by HP Customer Care — award-winning service and support. HP Customer Care is our promise to provide support solutions that keep you up and running...and learning how to do more with your HP LaserJet 3150 product.

## Proactive notification

When you sign up for Proactive Notification, we will send you e-mail about topics of your choice, like: updated software, product announcements, and other important news on your HP LaserJet 3150 product. Sign up online at <http://www.hp.com/support/lj3150>. (Site is in English.)



## By phone

Speak with a trained service technician who specializes in your HP LaserJet 3150 product. Call:

Australia: +61 3 8877 8000

India: 91 11 682 6035

Ireland: +353 (0)1 662 5525

Malaysia: +60 3 295 2566

Singapore: +65 272 5300

South Africa: +27 (0)11 8061030

Before calling, please have the purchase date and note the product model and serial numbers, which are on the back of the product, or you might have written them on the inside front cover.



---

# 3

## Exploring the product and software

### What you will learn

This section will help you learn the basics of the HP LaserJet 3150 product. It contains the most general information about how to do everyday tasks. You'll also find many pointers to more information and how to get help.

You will learn:

- how to use the control panel to send a fax and make a copy
- about the software features
- how to use the Document Assistant to send a fax, make a copy, and scan an item
- about how OCR software works



## Exploring the product

1

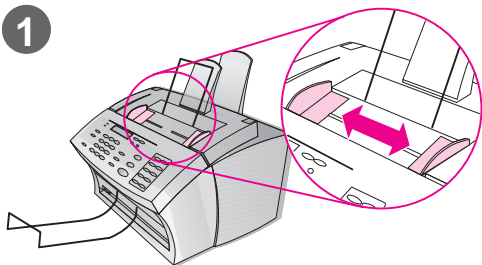

### Loading items to be faxed, copied, or scanned

Whether you are faxing, copying, or scanning using the software, the procedure for loading the item is the same.

#### To load an item

- 1 Adjust the guides in the document feeder tray to the size of the demonstration page you printed earlier in the setup.
- 2 Place the page top first, face down, into the document feeder tray.

Wait for the HP LaserJet 3150 product to load the page.

2

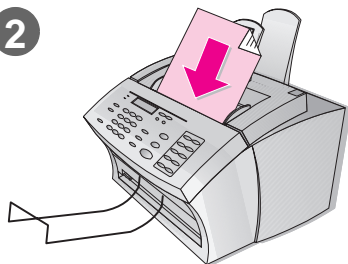

### Check your work

Does the control panel display say DOCUMENT LOADED PHONE# OR #COPIES?

- Yes.** Go to “Sending a fax using the control panel” on page 62.
- No.** Gently pull the top of the control panel toward you until it releases. Remove the document, close the control panel, and reinsert the document. When you are ready, go to “Sending a fax using the control panel” on page 62.

### Important!

Important, detailed guidelines regarding the size and type of items you can load and how to load special items (such as photographs and newspaper articles) appear in the “Faxing” chapter of the user guide. See these guidelines before loading any other items.

## Sending a fax using the control panel

You can send a fax using the control panel. If you installed the software and your computer is on, the Document Assistant appears on the computer screen when you load a document in the document feeder tray. As soon as you start the fax using the control panel, the Document Assistant disappears.

### To send a fax using the control panel

- 1 After the fax is loaded in the document feeder tray, dial the fax number using the numeric keys.

#### Note

Include any pauses or other needed numbers, such as an area code, an access code for numbers outside a PBX system (usually a 9 or 0), or a long distance prefix.

- 2 Press **START** to begin faxing.

### Check your work

Does the control panel display say 1 **PAGE SENT** and then return to the **READY** state?

**Yes.** Go to “Exploring the software” on page 63.

**No.** Do the following:

- If there is an error message on the control panel display, correct the problem indicated. Then, try resending the fax.
- Ask someone you know to send a fax to you to confirm you can receive faxes.
- See the Troubleshooting and Maintenance chapter of the user guide for more information.

When you are ready, Go to “Exploring the software” on page 63.

### If you normally dial a prefix

You can program a dialing prefix that is added to all outgoing numbers dialed at the control panel. See the “Managing Basic Features” chapter in the user guide.

### To learn more

For more information about sending faxes from the control panel, see the “Faxing” chapter in the user guide.





## Exploring the software

You must have installed the software on your computer to explore the features and do the tasks in this section. Once you read the overview, use the instructions later in this section to send a fax, make a copy, and scan using the software.

### Overview

The three, main parts of the software that you see and use regularly are the Document Assistant, the document viewer, and the desktop.

### Introducing the Document Assistant

To see and use the Document assistant, the product must be directly connected to your computer. The Document Assistant is a dialog box that appears on the computer screen when you load a document into the document feeder tray.

If you have a compatible e-mail program, four icons appear on this screen. Otherwise, only three appear. Click anywhere on the Document Assistant to activate it.



Click anywhere on this screen to activate it

Once activated, the Document Assistant displays buttons for the pc fax, pc copy, and scan functions. If you have a compatible e-mail program, a **Scan to E-mail** button also appears. Click the button for the function you want:

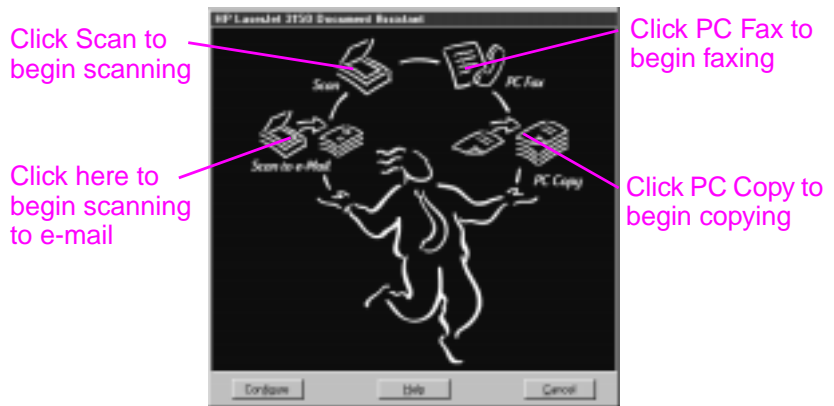

At the bottom of the Document Assistant are the **Configure**, **Help**, and **Cancel** buttons. Click **Configure** to use the software and HP LaserJet 3150 product configuration settings. **Help** takes you to the Help for the JetSuite Pro software and the HP LaserJet 3150 product. Clicking **Cancel** closes the Document Assistant.

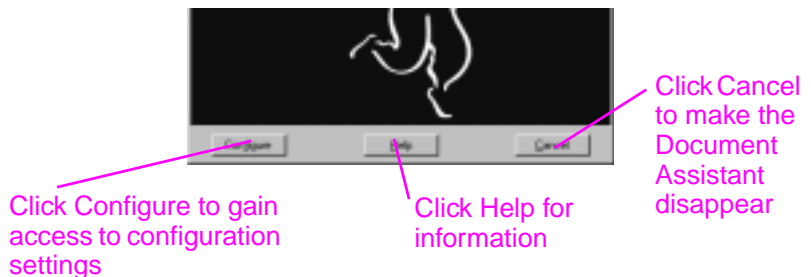

To fax or copy a document, you can use this Document Assistant or the product control panel. (If you choose the control panel, the Document Assistant closes.) If you are scanning (or scanning to e-mail), you must begin the task using the Document Assistant, the JetSuite Pro software, or another program (such as a TWAIN-compliant one). You *cannot* use the control panel.

## Introducing the document viewer

When you initiate a scan from the Document Assistant or the JetSuite Pro software, the scanned item appears as an unnamed file in the document viewer of the JetSuite Pro software. Identify the different parts of the document viewer window:

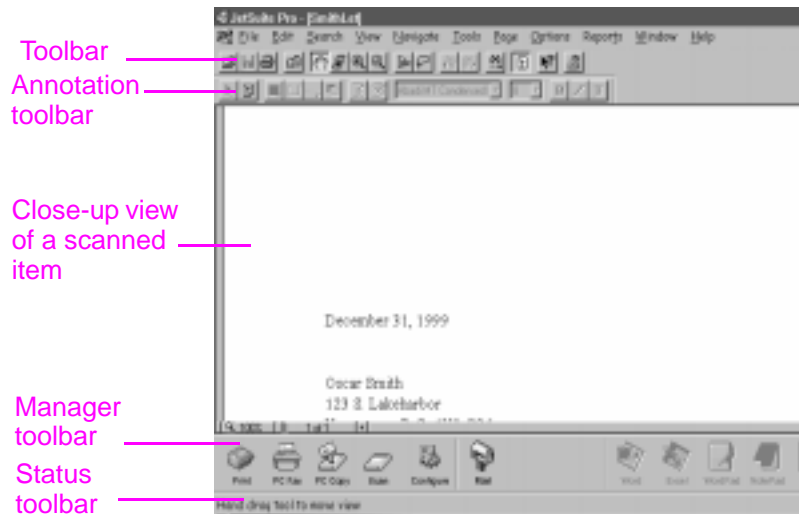

The document viewer allows you to work with the content of the scanned item. Use the document viewer to:

- highlight text or images or add electronic sticky notes using the annotation tools.
- clean up or adjust the scanned item.
- send the item to print or fax, or attach it to an e-mail message.

## Introducing the desktop

When you close a document in the document viewer, it appears as a thumbnail (a small image) or file name in the desktop of the JetSuite Pro software. Identify the following features on the desktop:

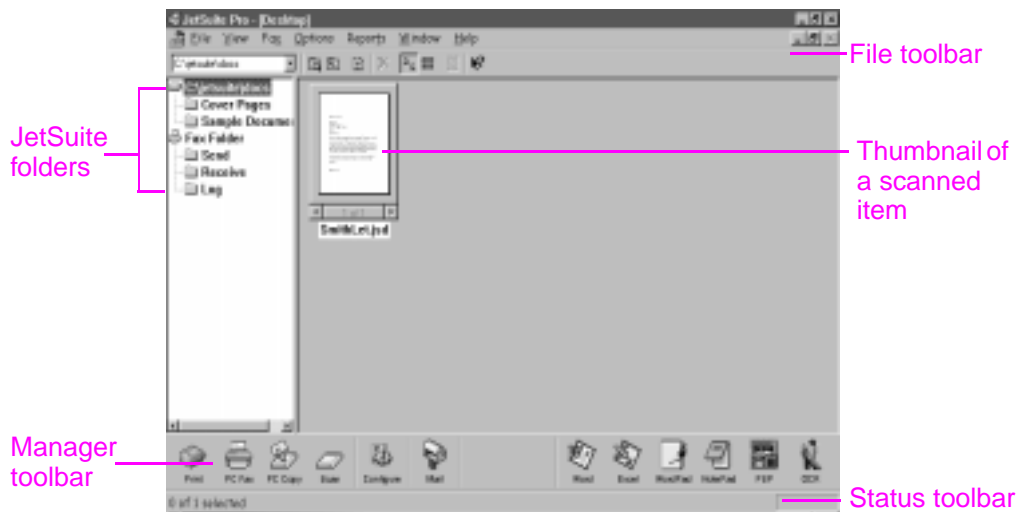

### Note

Network users do not see the Fax Receive folder or related features or options. They also do not see the PC Copy icon, features, or options.

The desktop shows thumbnails of .jsd documents and icons of documents in other graphics file formats or file formats for common word-processing, spreadsheet, and presentation programs. Use the desktop to:

- organize and file a saved, scanned item in a folder.
- send the scanned item to another program, such as a word-processing program.
- manage faxes sent from the computer and view fax logs for all faxes. A user whose computer is directly connected to the product can also manage faxes received to the computer.

To view a .jsd document again in the document viewer, double-click its thumbnail. If you double-click the thumbnail of a file on the desktop with a different format, the file opens in the program associated with that extension on your computer.

For more information about scanning and the JetSuite software, see chapter 5, "Scanning," in the user guide and the Help.

---

## Using Help

You installed the Help when you installed the JetSuite Pro software. Help contains detailed procedures that guide you through any task you want to perform from the software. It provides information that is specific to the current task. Help is also a troubleshooting tool. When questions arise or a problem occurs, the quickest way to find a solution is to access your Help.

Help contains the following general topics:

**Installation Help** — provides help for installing the software and determining required settings.

**General Information Help** — gives overview information for the print, fax, copy, and scan functions. Also gives overview information for the JetSuite Pro software.

**Troubleshooting** — gives solutions for common problems.

**How Do I** — provides step-by-step instructions for printing, faxing, copying, scanning, configuration, and other JetSuite Pro software tasks.

You can access Help by:

- clicking **Help** on the Document Assistant or any screen where the **Help** button appears.
- selecting **Contents** from the **Help** menu on the desktop or document viewer.
- pressing **F1** on the computer keyboard.

## Accessing the JetSuite Pro software

You can access the JetSuite Pro software by:

- using the Document Assistant, as described earlier
- using the Program Manager in Windows 3.1x or the **Start** menu in Windows 9x, NT 4.0, or 2000
- double-clicking the HP LaserJet 3150 product icon on the Windows 9x, NT 4.0, or 2000 taskbar (at the bottom, right of the screen)
- double-clicking the JetSuite Pro icon on the Windows desktop (for Windows 9x, NT 4.0, or 2000 only)

## Sending a fax using the Document Assistant

The product must be directly connected to your computer for you to see and use the Document Assistant. Then, you can send a fax by clicking **PC Fax** on the Document Assistant.

### To send a fax using the Document Assistant

- 1 After you load the document in the document feeder tray, the Document Assistant appears on the computer screen. Click anywhere on the Document Assistant to activate it.
- 2 Click **PC Fax**.

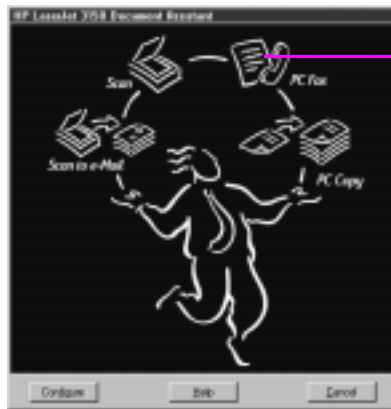

Click here

- 3 When the **JetSuite PC Send Fax** dialog box appears, type the recipient's name and fax number and add a cover page (optional).
- 4 Click **Send Fax** to begin sending the fax.

### To learn more

See the "Faxing" chapter in the user guide for more detail about when to fax from the control panel, the Document Assistant, the JetSuite Pro Desktop or another program such as a word-processing program.

For more information about using the Document Assistant and JetSuite Pro software, see the Help.

## Making a copy using the Document Assistant

The product must be directly connected to your computer for you to see and use the Document Assistant. Then, you can initiate a copy by clicking **PC Copy** on the Document Assistant.

### To make a copy using the Document Assistant

- 1 After you load the document in the document feeder tray, the Document Assistant appears on the computer screen. Click anywhere on the Document Assistant to activate it.
- 2 Click **PC Copy**.

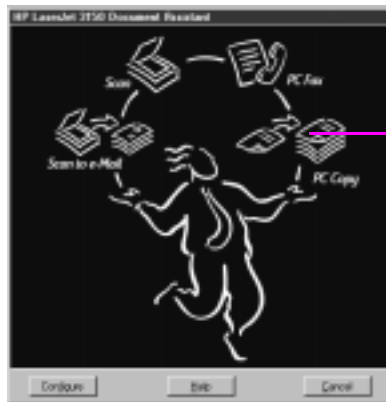

Click here

- 3 In the dialog box that appears, adjust options, such as contrast and pages per sheet.
- 4 Click **Start Copy** to begin copying.

### To learn more

See the “Copying” chapter in the user guide for more detail about when to choose to copy from the control panel or the Document Assistant.

For more information about using the Document Assistant, see the Help.

## Scanning an item

You must have installed the software to scan an item. You can start a scan from the Document Assistant or the JetSuite Pro software by clicking **Scan**. (To see and use the Document Assistant, the product must be directly connected to your computer.)

When the next dialog box opens, you have three destination options: **Scan to JetSuite Desktop Viewer**, **Scan to File**, or **Scan to Text**.

- Select **Scan to JetSuite Desktop Viewer** (the default) to place the item in the document viewer of the JetSuite Pro software. Using this program, you can annotate, organize, and store important documents.
- Select **Scan to File** to create a file of the item without viewing it now.
- Select **Scan to Text**, to convert the item to editable text and open it as an unnamed file in your word-processing program.

### To scan using the Document Assistant

- 1 Load the document into the document feeder tray.
- 2 When the Document Assistant appears, click anywhere on it to activate it.
- 3 Click **Scan**.

Click here



- 4 In the dialog box that appears, adjust any options, such as contrast, ensure **Scan to JetSuite Desktop Viewer** is selected, and click **Start Scan**.
- 5 After it has been scanned, the item appears in the document viewer. Explore the options: Add annotations and hyperlinks, and then send the item to fax, print, or another task.



---

## To scan using the JetSuite Pro software

- 1 In the JetSuite Pro desktop or document viewer, click the Scan icon on the **Manager** toolbar.
- 2 In the dialog box that appears, adjust any settings, such as scan mode or contrast.
- 3 Choose **Scan to JetSuite Desktop Viewer**, **Scan to File**, or **Scan to Text** as the destination.
- 4 Select the **Use Start button on device to begin scan** check box. The **Start Scan** button becomes unavailable, and the scanner path on the product is now unavailable to other users for the next three minutes.
- 5 At the HP LaserJet 3150 product, load the document into the document feeder tray.
- 6 Press **Start**. The document is scanned item goes to the destination you chose.

---

### Hint

You can also start a scan from the JetSuite Pro software by clicking the Scan icon on the **Manager** toolbar, loading the document, and returning to the computer to click **Start Scan**. In this case, make sure the **Use the Start button on device to begin scan** check box is cleared.

---

---

## Scanning to text using OCR

When you are scanning an item and choose **Scan** on the Document Assistant or in the JetSuite Pro software and then select **Scan to Text**, the JetSuite Pro software initiates the scan using the best settings for text. Then, the OCR software discards any graphics on the scanned item and converts the text to editable text. When the OCR software has finished, the converted text appears as an untitled file in your word-processing program.

*Because OCR conversions are never perfect, proof the converted text carefully.*

### To learn more

For more information about scanning and the OCR software, see the “Scanning” chapter in the user guide, and see the Help.

For more information about scanning to e-mail, see the “E-mailing Portable Documents” chapter in the user guide, and see the Help.

## Taking the next step

Congratulations! You have successfully set up the product and you can now put it to work helping you save time. Explore these additional sources of information:

- **See the user guide** for more information on how to do day-to-day tasks, adjust seldom-changed settings, use troubleshooting, order parts, and more.
- **See the Help** for more information on using the software for day-to-day tasks, changing settings, and troubleshooting.
- **Register your product!** Your name is never sold, and your privacy is protected. *And registering the product ensures that you are notified when software and firmware upgrades become available, so you can always have the most current features, fixes, and information.*
- **Use HP Customer Care, and not just when you have a problem.** On page page 58, find out how to obtain information in fast, convenient ways, such as visiting the HP LaserJet 3150 product website, e-mailing, and even talking to a real, live person.

### Do you know?

The HP LaserJet 3150 product still works like a regular fax machine and copier when you turn off the computer or the software is not working. Even if you normally receive faxes to your computer and you turn it off, faxes are received into the product memory and will upload to the computer when you turn it on again.

---

# 4 Warranty

## Warranty information

### Hewlett-Packard limited warranty statement

HP LaserJet 3150 product      ONE-YEAR LIMITED WARRANTY

- 1 HP warrants to you, the end-user customer, that HP hardware, accessories, and supplies, will be free from defects in materials and workmanship after the date of purchase, for the period specified above. If HP receives notice of such defects during the warranty period, HP will, at its option, either repair or replace products which prove to be defective. Replacement products may be either new or like-new.
- 2 HP warrants to you that HP software will not fail to execute its programming instructions after the date of purchase, for the period specified above, due to defects in material and workmanship when properly installed and used. If HP receives notice of such defects during the warranty period, HP will replace software media which does not execute its programming instructions due to such defects.
- 3 HP does not warrant that the operation of HP products will be uninterrupted or error free. If HP is unable, within a reasonable time, to repair or replace any product to a condition as warranted, you will be entitled to a refund of the purchase price upon prompt return of the product.
- 4 HP products may contain remanufactured parts equivalent to a new in performance or may have been subject to incidental use.
- 5 Warranty does not apply to defects resulting from (a) improper or inadequate maintenance or calibration, (b) software, interfacing, parts or supplies not supplied by HP, (c) unauthorized modification or misuse, (d) operation outside of the published environmental specifications for the product, or (d) improper site preparation or maintenance.

- 
- 6 HP MAKES NO OTHER EXPRESS WARRANTY OR CONDITION WHETHER WRITTEN OR ORAL.** TO THE EXTENT ALLOWED BY LOCAL LAW, ANY IMPLIED WARRANTY OR CONDITION OR MERCHANTABILITY, SATISFACTORY QUALITY, OR FITNESS FOR A PARTICULAR PURPOSE IS LIMITED TO THE DURATION OF THE EXPRESS WARRANTY SET FORTH ABOVE. Some countries, states or provinces do not allow limitations on the duration of an implied warranty, so the above limitation or exclusion might not apply to you. This warranty gives you specific legal rights and you might also have other rights that vary from country to country, state to state, or province to province.
  - 7 TO THE EXTENT ALLOWED BY LOCAL LAW, THE REMEDIES IN THIS WARRANTY STATEMENT ARE YOUR SOLE AND EXCLUSIVE REMEDIES.** EXCEPT AS INDICATED ABOVE, IN NO EVENT WILL HP OR ITS SUPPLIERS BE LIABLE FOR LOSS OF DATA OR FOR DIRECT, SPECIAL, INCIDENTAL, CONSEQUENTIAL (INCLUDING LOST PROFIT OR DATA), OR OTHER DAMAGE, WHETHER BASED IN CONTRACT, TORT, OR OTHERWISE. Some countries, states or provinces do not allow the exclusion or limitation of incidental or consequential damages, so the above limitation or exclusion may not apply to you.
  - 8 (AUSTRALIA AND NEW ZEALAND ONLY) THE WARRANTY TERMS CONTAINED IN THIS STATEMENT, EXCEPT TO THE EXTENT LAWFULLY PERMITTED, DO NOT EXCLUDE, RESTRICT OR MODIFY AND ARE IN ADDITION TO THE MANDATORY STATUTORY RIGHTS APPLICABLE TO THE SALE OF THIS PRODUCT TO YOU.**

---

## Year 2000 warranty

Subject to all of the terms and limitations of the HP Limited Warranty Statement provided with this HP Product, HP warrants that this HP product will be able to accurately process date data (including, but not limited to, calculating, comparing, and sequencing) from, into, and between the 20th and 21st centuries, and the year 1999 and 2000, including leap year calculations, when used in accordance with the Product documentation provided by HP (including any instructions for installing patches or upgrades), provided that all other products (e.g., hardware, software, firmware) used in combination with such HP product(s) properly exchange date data. The duration of the Year 2000 warranty extends through January 31, 2001.

HP makes no representation or warranty respecting the accuracy or reliability of information about non-HP products. Such information is provided by manufacturers of those products, and customers are urged to contact the manufacturer directly to verify Year 2000 readiness.

# Index

## Symbols

.jsd documents 66

## Numerics

10/100Base-TX connection 13

10Base-T connection 13

## A

adaptors

module double 8

RJ11 23, 24

adjusting speaker volume 46

analog telephone lines 11

Annotation toolbar 65

answer mode

default 50

description 50

setting 50

answering machine, connecting 27, 29

arrow keys on control panel 17

attaching

answering machine 27, 29

choosing what devices to connect 25

computer with internal modem 28

dedicated fax line 26

directly to a computer using a parallel cable 36

external modem 29

HP LaserJet 3150 product 23, 24

HP LaserJet 3150 product only 23

modem 27

other devices 27

paper loading label 21

shared line 26

supports 20

telephone 27, 30

telephone cord 11

to network using HP JetDirect print server 42

automatic answer mode. *See* answer mode 7

available disk space, not enough 55

avoiding jams 21, 22

## B

backup, battery 31

battery backup 31

bidirectional communication

not established 56, 57

requirements 12

bins

paper input 16

paper output 16

BNC connection 13

box contents 8

buttons

Cancel 64

Configure 64

control panel 17

Help 64, 67

Scan to E-mail 64

## C

cables

network 13

parallel 8, 36

call waiting 11

Cancel button 64

card for product registration 8

cartridges, toner

illustration 8

installing 18

preventing damage 18

recycling 19

CD-ROM

damaged 55

unable to read 55

checking

firmware revisions 13

hardware installation 33

cleaning toner from clothing 18

clearing actions using control panel 17

closing Document Assistant 64

clothing, cleaning toner from 18

COM ports not available 55

communication not established 56, 57

compact disc. *See* CD-ROM 7

compatible software 38, 43

Configure button 64

configuring

answer mode 50

dialing prefixes 62

fax header 48

rings-to-answer setting 50

connecting

answering machine 27, 29

choosing what devices to connect 25

computer with internal modem 28

dedicated fax line 26

connecting (continued)  
directly to a computer using a parallel cable 36  
external modem 29  
HP LaserJet 3150 product 23, 24  
HP LaserJet 3150 product only 23  
modem 27  
other devices 27  
shared line 26  
supports 20  
telephone 27, 30  
telephone cord 11  
to network using HP JetDirect print server 42  
to the Internet 25  
to wall jack 23  
connections  
10/100Base-TX 13  
10Base-T 13  
BNC 13  
network 13  
Token Ring 13  
contents of box 8  
contrast key on control panel 17  
control panel  
illustration 15  
keys and lights 17  
using to fax, copy, or scan 64  
copy key on control panel 17  
copying  
guidelines 69  
using the control panel 64  
using the Document Assistant 69  
cord, power  
connecting 31  
illustration 8  
cord, telephone  
connecting 11  
illustration 8  
Custom installation 37, 43  
customer support. *See* HP Customer Care

## D

data modem. *See* modem  
date  
setting for fax 47  
where displayed 17  
dedicated fax line 26  
dedicated lines  
connecting 26  
description 11  
defaults  
answer mode 50  
rings to answer 50  
demonstration page 33  
desktop. *See* JetSuite Pro desktop

destination options for scanning 70  
dial tone missing 32  
dialing prefixes 62  
digital telephone lines 11  
disk drive, external, connecting 12  
disk space  
not enough 55  
requirements 12  
distinctive ring  
description 52  
enabling 52  
Document Assistant  
closing 64  
description 63  
using to access JetSuite Pro software 67  
using to copy 69  
using to scan 70  
using to send faxes 68  
document feeder support  
attaching 20  
illustration 8  
document feeder tray 15  
document output slot 15  
document output support  
attaching 20  
illustration 8  
document release door 15  
document viewer  
purpose 65  
toolbars 65  
window description 65  
documentation  
included in box 8  
sources for help and information 73  
doors  
document release 15  
printer 16  
double adaptor 8  
downloading print servers 13

## E

electrical surges 11  
e-mail customer support 58  
enabling distinctive ring 52  
enter key on control panel 17  
EPP ports 56  
equipment testing 33  
error light on control panel 17  
error messages  
installation 55  
where displayed 17  
exiting menu settings 17  
Express installation 37, 43  
external disk drive, connecting 12  
external modem. *See* modem



## F

- fax
  - answer mode 50
  - date and time settings 47
  - required features 46
  - rings to answer 50
- fax header 48
- fax line, connecting 26
- fax logs 66
- fax software. *See* PC fax software 7
- faxing
  - guidelines 68
  - troubleshooting 62
  - using the control panel 62
  - using the Document Assistant 68
  - viewing logs 66
- features of the product 7, 10
- files
  - .jsd 66
  - graphics discarded by OCR 72
  - scanning to 70
- firmware revisions for print servers 13
- Freecell program 39
- front paper output slot 16

## G

- graphics discarded by OCR software 72

## H

- hard disk space requirements 12
- hardware
  - testing 33
  - troubleshooting 55
- header for faxes 48
- Help button 64, 67
- help, online
  - customer support 58
  - using 67
- HP Customer Care
  - contacting 58
  - e-mail support 58
  - online support 58
  - phone support 59
  - Proactive Notification 59
  - user forums 58
  - website 58
- HP JetDirect print servers
  - configuring 44
  - models 13
  - using to connect to product 42

## I

- information sources 73
- inserting a pause in a fax 17
- installation
  - components installed 37, 43
  - Custom 37, 43
  - Express 37, 43
  - messages 55
  - online help 67
  - requirements 12
  - sharing with other users 41
  - testing product and software 45
  - testing the hardware 33
  - troubleshooting 55
  - unpacking 8
- installing
  - software 37, 43
  - software in Windows 3.1x 39
  - software in Windows 95/NT 4.0 39, 44
- internal modem. *See* modem
- Internet, connecting to 25
- IPX/SPX
  - requirement 13
  - using to connect product 44
- item doesn't load 61

## J

- jack, connecting to 23
- jams, avoiding 21, 22
- JetDirect print servers
  - configuring 44
  - models 13
  - using to connect to product 42
- JetSuite Pro desktop
  - description 66
  - folders 66
  - toolbars 66
  - window description 66
- JetSuite Pro software
  - accessing 67
  - description 67
  - desktop 66
  - document viewer 65
  - using to scan 71

## K

- keys
  - on control panel 17
  - programming for special dialing codes 46

## L

- label, paper loading
  - attaching 21
  - illustration 8
- latches for releasing printer door 16
- lever, paper path 16
- lights on control panel 17
- lines
  - analog 11
  - dedicated 11
  - digital 11
  - shared 11
  - telephone 11
- loading
  - guidelines 61
  - items to be faxed, copied, or scanned 61
  - media 22
  - problem 61
  - special items 61
- logs for faxes 66

## M

- manual answer mode. *See* answer mode
- Manual Dial key on control panel 17
- media
  - jams 21, 22
  - loading 22
- memory requirements 12
- menu key on control panel 17
- menu settings
  - exiting 17
  - scrolling through 17
- messages
  - installation 55
  - where displayed 17
- modem
  - connecting 27
  - data 25
  - external 25, 26, 29
  - internal 25, 26, 28
  - using with HP LaserJet 3150 product 25
- modes
  - answer 50
  - automatic and manual answer 50
  - operating 10
- modular double adaptor 8

## N

- network
  - adding the printer driver 41
  - connecting using HP JetDirect print server 42
  - requirements 13
  - sharing with other users 41
- no dial tone 32
- not enough disk space 55

- Novell servers 13

## O

- OCR
  - graphics discarded during 72
  - using to scan text 72
- one-touch keys 17
- online help
  - customer support 58
  - using 67
- online user forum 58
- operating modes 10
- optical character recognition (OCR). *See* OCR
- overview of the product 7

## P

- paper
  - jams 22
  - loading 22
- paper input bin 16
  - illustration 16
  - loading 22
- paper input support
  - attaching 20
  - illustration 8
- paper loading label
  - attaching 21
  - illustration 8
- paper output bin 16
- paper output support
  - attaching 20
  - illustration 8
- paper path lever 16
- parallel cable
  - connecting directly to computer with 36
  - illustration 8
- parallel ports
  - areas of conflict 12
  - installation requirements 12
- parts
  - illustration for printer path 16
  - illustration for scanner path 15
  - unpacking 8
- path
  - printer 16
  - scanner 15
- pause key on control panel 17
- PBX systems 62
- PC fax software
  - included with HP LaserJet 3100 product 43
  - included with HP LaserJet 3150 product 38
  - using your own 38, 43
- phone lines
  - dedicated 26
- phone. *See* telephone

- ports
  - device conflicts 12
  - EPP 56
  - installation requirements 12
  - not available 55
  - serial 36
  - TCP/IP printing services 44
  - unidirectional 56
- power
  - interruptions 11
  - strip recommendation 31
  - supply backup 31
  - switch 31
- power cord
  - connecting 31
  - illustration 8
- print servers
  - adding to network computers 41
  - checking firmware revisions 13
  - downloading 13
  - HP JetDirect 42
  - models 13
  - upgrading 13
- printer 16
  - door 16
  - path 16
- printing
  - document test 40, 45
  - self-test report 54
- Proactive Notification 59
- problems. *See* troubleshooting
- product announcements 59
- product registration card 8
- product warranty 74
- programming keys for special dialing codes 46
- protectors, surge 11
- protocol requirement 13

## R

- RAM (random access memory) requirements 12
- random access memory (RAM) requirements 12
- ready light on control panel 17
- recycling toner cartridges 19
- redial key on control panel 17
- registration card 8
- release latches 16
- requirements for installation 12
- resolution key on control panel 17
- rings to answer
  - changing 50
  - default 50
- RJ11 socket and adaptor 23, 24

## S

- Scan to E-mail button 64
- scanner
  - parts 15
  - path 15
- scanning 70
  - description 70
  - destination options 70
  - guidelines 72
  - to document viewer 70
  - to file 70
  - to text 70
  - to text using OCR 72
  - using the Document Assistant 70
  - using the JetSuite Pro software 71
- scanning software, TWAIN-compliant 38, 43
- scans in network mode 17
- self-test report 54
- sending faxes. *See* faxing 73
- serial ports 36
- setting
  - fax answer mode 50
  - fax features 46
  - fax header information 48
- shared lines
  - connecting 26
  - description 11
  - rings-to-answer 50
- sharing the product 41
- single-sheet input 16
- single-sheet input slot 16
- socket for RJ11 23, 24
- software
  - compatible 38, 43
  - installing 37, 43
  - list of components installed 43
  - troubleshooting 55
  - TWAIN-compliant scanning 38, 43
  - updates 58, 59
- sound, controlling with control panel 17
- speaker volume 46
- special media lever 15
- speed dial key on control panel 17
- start key on control panel 17
- starting
  - copy function 17
  - paper faxes 17
- stop key on control panel 17
- stopping actions using control panel 17
- support. *See* HP Customer Care
- supports
  - attaching 20
  - illustration 8
  - unpacking 8

surge protectors 11  
switch box, connecting 12  
switch, power 31  
system requirements 12

**T**

TCP/IP  
  printing services port 44  
  requirement 13

technical support. *See* HP Customer Care 22

telephone  
  connecting 27, 30  
  lines. *See* phone lines  
  lists. *See online help*  
  lists. *See software help*

telephone cord  
  connecting 11  
  illustration 8

telephone customer support 59

testing  
  hardware 33  
  printing a self-test report 54  
  product and software 40, 45

text  
  scanning to 70  
  scanning to using OCR 72

thumbnails 66

time  
  setting for fax 47  
  where displayed 17

Token Ring connection 13

toner cartridges  
  illustration 8  
  installing 18  
  preventing damage 18  
  recycling 19

toner, cleaning from clothing 18

training 58

tray, document feeder 15

troubleshooting 61  
  fax delivery 62  
  installation 55  
  printing a self-test report 54  
  using online help 67

TWAIN-compliant software 38, 43, 64

**U**

unidirectional ports 56

uninterruptible power supply (UPS) 31

unpacking 8

updating software 58, 59

upgrading print servers 13

UPS (uninterruptible power supply) 31

user forum support 58

**V**

voicemail  
  description 11  
  using with dedicated fax lines 26

volume for speaker 46

volume key on control panel 17

**W**

wall jack, connecting to 23

warranty  
  product 74  
  year 2000 76

websites  
  HP Customer Care 58  
  HP website 13

Win32s program 39

Windows  
  installation requirements 12  
  installing HP LaserJet 3100 software in 43  
  installing HP LaserJet 3150 software in 37  
  installing software in Windows 3.1x 39  
  installing software in Windows 95/NT 4.0 39, 44  
  sharing 41

**Y**

year 2000 (Y2K) warranty 76

Store product documents and your sales receipt here.



**Register your product!** Your name is never sold, and your privacy is protected. And registering the product ensures that you are notified when software and firmware upgrades become available, so you can always have the most current features, fixes, and information.





Copyright© 2000  
Hewlett-Packard Co.  
Printed in Singapore

Manual Part No.  
C4256-90922



Printed on  
Recycled Paper



C4256-90922

## Free Manuals Download Website

<http://myh66.com>

<http://usermanuals.us>

<http://www.somanuals.com>

<http://www.4manuals.cc>

<http://www.manual-lib.com>

<http://www.404manual.com>

<http://www.luxmanual.com>

<http://aubethermostatmanual.com>

Golf course search by state

<http://golfingnear.com>

Email search by domain

<http://emailbydomain.com>

Auto manuals search

<http://auto.somanuals.com>

TV manuals search

<http://tv.somanuals.com>