

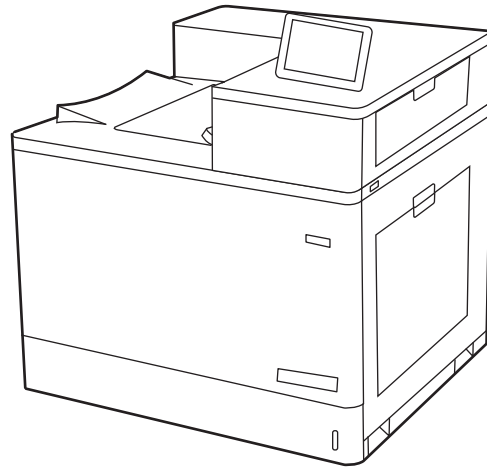

# HP Color LaserJet Managed E85055

## User Guide



[www.hp.com/videos/LaserJet](http://www.hp.com/videos/LaserJet)  
[www.hp.com/support/colorljE85055](http://www.hp.com/support/colorljE85055)





HP Color LaserJet Managed E85055

User Guide

## Copyright and License

© Copyright 2019 HP Development Company, L.P.

Reproduction, adaptation, or translation without prior written permission is prohibited, except as allowed under the copyright laws.

The information contained herein is subject to change without notice.

The only warranties for HP products and services are set forth in the express warranty statements accompanying such products and services. Nothing herein should be construed as constituting an additional warranty. HP shall not be liable for technical or editorial errors or omissions contained herein.

Edition 1, 10/2019

## Trademark Credits

Adobe®, Adobe Photoshop®, Acrobat®, and PostScript® are trademarks of Adobe Systems Incorporated.

Apple and the Apple logo are trademarks of Apple Inc., registered in the U.S. and other countries.

macOS is a trademark of Apple Inc., registered in the U.S. and other countries.

AirPrint is a trademark of Apple Inc., registered in the U.S. and other countries.

Google™ is a trademark of Google Inc.

Microsoft®, Windows®, Windows® XP, and Windows Vista® are U.S. registered trademarks of Microsoft Corporation.

UNIX® is a registered trademark of The Open Group.

---

# Table of contents

<b>1 Printer overview</b> .....	<b>1</b>
Warning icons .....	1
Potential shock hazard .....	2
Printer views .....	4
Printer front view .....	4
Printer back view .....	5
Interface ports .....	5
Control-panel view .....	7
How to use the touchscreen control panel .....	8
Printer specifications .....	10
Technical specifications .....	10
Supported operating systems .....	11
Printer dimensions .....	13
Power consumption, electrical specifications, and acoustic emissions .....	15
Operating-environment range .....	15
Printer hardware setup and software installation .....	15
<b>2 Paper trays</b> .....	<b>17</b>
Introduction .....	17
Load paper to Tray 1 (multipurpose tray) .....	19
Load Tray 1 (multipurpose tray) .....	19
Tray 1 paper orientation .....	20
Use alternative letterhead mode .....	26
Enable Alternative Letterhead Mode by using the printer control-panel menus .....	26
Load paper to Tray 2 .....	27
Load Tray 2 .....	27
Tray 2 paper orientation .....	29
Use alternative letterhead mode .....	33
Enable Alternative Letterhead Mode by using the printer control-panel menus .....	33
Load paper to the 550-sheet paper tray .....	34
Load paper to the 550-sheet paper tray .....	34
550-sheet paper tray paper orientation .....	36

Use alternative letterhead mode .....	40
Enable Alternative Letterhead Mode by using the printer control-panel menus .....	40
Load paper to the 2 x 550-sheet paper trays .....	41
Load paper to the 2 x 550-sheet paper trays .....	41
2 x 550-sheet paper tray paper orientation .....	43
Use alternative letterhead mode .....	47
Enable Alternative Letterhead Mode by using the printer control-panel menus .....	47
Load paper to the 2,700-sheet high-capacity input paper trays .....	48
Load paper to the 2,700-sheet high-capacity input paper trays .....	48
2,700-sheet HCI paper tray paper orientation .....	49
Use alternative letterhead mode .....	53
Enable Alternative Letterhead Mode by using the printer control-panel menus .....	53
Load and print envelopes .....	54
Print envelopes .....	54
Envelope orientation .....	54
Load and print labels .....	56
Manually feed labels .....	56
Label orientation .....	56
<b>3 Supplies, accessories, and parts .....</b>	<b>59</b>
Order supplies, accessories, and parts .....	60
Ordering .....	60
Replace the toner cartridges .....	61
Toner-cartridge information .....	61
Remove and replace the cartridges .....	62
Replace the toner-collection unit .....	64
Toner-collection unit information .....	64
Remove and replace the toner-collection unit .....	64
<b>4 Print .....</b>	<b>67</b>
Print tasks (Windows) .....	68
How to print (Windows) .....	68
Automatically print on both sides (Windows) .....	68
Manually print on both sides (Windows) .....	69
Print multiple pages per sheet (Windows) .....	69
Select the paper type (Windows) .....	70
Additional print tasks .....	71
Print tasks (macOS) .....	72
How to print (macOS) .....	72
Automatically print on both sides (macOS) .....	72
Manually print on both sides (macOS) .....	73

Print multiple pages per sheet (macOS) .....	73
Select the paper type (macOS) .....	73
Additional print tasks .....	74
Store print jobs on the printer to print later or print privately .....	75
Introduction .....	75
Create a stored job (Windows) .....	75
Create a stored job (macOS) .....	76
Print a stored job .....	77
Delete a stored job .....	78
Delete a job that is stored on the printer .....	78
Change the job storage limit .....	78
Information sent to printer for Job Accounting purposes .....	78
Mobile printing .....	79
Introduction .....	79
Wi-Fi, Wi-Fi Direct Print, NFC, and BLE printing .....	80
Enable wireless printing .....	80
Change the Wi-Fi Direct name .....	80
HP ePrint via email .....	81
AirPrint .....	81
Android embedded printing .....	82
Print from a USB flash drive .....	83
Enable the USB port for printing .....	84
Method one: Enable the USB port from the printer control panel .....	84
Method two: Enable the USB port from the HP Embedded Web Server (network-connected printers only) .....	84
Print USB documents .....	84
Print using high-speed USB 2.0 port (wired) .....	86
Method one: Enable the high-speed USB 2.0 port from the printer control panel menus .....	86
Method two: Enable the high-speed USB 2.0 port from the HP Embedded Web Server (network-connected printers only) .....	86

## 5 Manage the printer ..... 87

Advanced configuration with the HP Embedded Web Server (EWS) .....	88
Introduction .....	88
How to access the HP Embedded Web Server (EWS) .....	88
HP Embedded Web Server features .....	90
Information tab .....	90
General tab .....	90
Print tab .....	91
Supplies tab .....	92
Troubleshooting tab .....	92

Security tab .....	92
HP Web Services tab .....	93
Networking tab .....	93
Other Links list .....	95
Configure IP network settings .....	96
Printer sharing disclaimer .....	96
View or change network settings .....	96
Rename the printer on a network .....	96
Manually configure IPv4 TCP/IP parameters from the control panel .....	97
Manually configure IPv6 TCP/IP parameters from the control panel .....	97
Link speed and duplex settings .....	98
Printer security features .....	100
Introduction .....	100
Security statements .....	100
Assign an administrator password .....	101
Use the HP Embedded Web Server (EWS) to set the password .....	101
Provide user access credentials at the printer control panel .....	101
IP Security .....	102
Encryption support: HP High Performance Secure Hard Disks .....	102
Lock the formatter .....	102
Energy-conservation settings .....	103
Set the sleep timer and configure the printer to use 1 watt or less of power .....	103
Set the sleep schedule .....	103
Set the idle settings .....	104
HP Web Jetadmin .....	104
<b>6 Solve problems .....</b>	<b>105</b>
Customer support .....	105
Control panel help system .....	106
Reset factory settings .....	107
Introduction .....	107
Method one: Reset factory settings from the printer control panel .....	107
Method two: Reset factory settings from the HP Embedded Web Server (network-connected printers only) .....	107
A “Cartridge is low” or “Cartridge is very low” message displays on the printer control panel .....	107
Printer does not pick up paper or misfeeds .....	109
Introduction .....	109
The printer does not pick up paper .....	109
The printer picks up multiple sheets of paper .....	112
Clear paper jams .....	116
Introduction .....	116



Paper jam locations .....	116
Auto-navigation for clearing paper jams .....	117
Experiencing frequent or recurring paper jams? .....	117
Clear paper jams in Tray 1 (13.A1) .....	117
Clear paper jams in Tray 2 (13.A2) .....	122
Clear paper jams in the fuser (13.B9, 13.B2, 13.FF) .....	128
Clear paper jams in the output bin (13.E1) .....	133
Clear paper jams in the duplex area (13.D3) .....	135
Clear paper jams in the 550-sheet trays (13.A3, 13.A4) .....	140
Clear paper jams in the 2 x 550 paper trays (13.A4, 13.A5) .....	147
Clear paper jams in the 2,700-sheet high-capacity input paper trays (13.A3, 13.A4, 13.A5, 13.A7) .....	154
Resolving color print quality problems .....	162
Introduction .....	162
Troubleshoot print quality .....	163
Update the printer firmware .....	163
Print from a different software program .....	163
Check the paper-type setting for the print job .....	164
Check the paper type setting on the printer .....	164
Check the paper type setting (Windows) .....	164
Check the paper type setting (macOS) .....	164
Check toner-cartridge status .....	165
Step one: Print the Supplies Status Page .....	165
Step two: Check supplies status .....	165
Print a cleaning page .....	165
Visually inspect the toner cartridge or cartridges .....	166
Check paper and the printing environment .....	167
Step one: Use paper that meets HP specifications .....	167
Step two: Check the environment .....	167
Step three: Set the individual tray alignment .....	167
Try a different print driver .....	168
Solve wired network problems .....	169
Introduction .....	169
Poor physical connection .....	169
The computer is unable to communicate with the printer .....	169
The printer is using incorrect link and duplex settings for the network .....	170
New software programs might be causing compatibility problems .....	170
The computer or workstation might be set up incorrectly .....	170
The printer is disabled, or other network settings are incorrect .....	170



---

# 1 Printer overview

Review the location of features on the printer, the physical and technical specifications of the printer, and where to locate setup information.

- [Warning icons](#)
- [Potential shock hazard](#)
- [Printer views](#)
- [Printer specifications](#)
- [Printer hardware setup and software installation](#)

For video assistance, see [www.hp.com/videos/LaserJet](http://www.hp.com/videos/LaserJet).

The following information is correct at the time of publication. For current information, see [www.hp.com/support/colorljE85055](http://www.hp.com/support/colorljE85055).

## For more information:

HP's all-inclusive help for the printer includes the following information:

- Install and configure
- Learn and use
- Solve problems
- Download software and firmware updates
- Join support forums
- Find warranty and regulatory information

## Warning icons

Use caution if you see a warning icon on your HP printer, as indicated in the icon definitions.

- Caution: Electric shock



- Caution: Hot surface



- Caution: Keep body parts away from moving parts

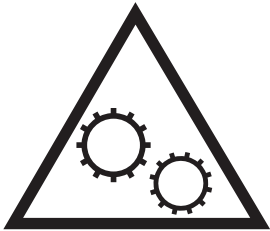

- Caution: Sharp edge in close proximity



- Warning



## Potential shock hazard

Review this important safety information.

- Read and understand these safety statements to avoid an electrical shock hazard.
- Always follow basic safety precautions when using this product to reduce risk of injury from fire or electric shock.
- Read and understand all instructions in the user guide.
- Observe all warnings and instructions marked on the product.
- Use only a grounded electrical outlet when connecting the product to a power source. If you do not know whether the outlet is grounded, check with a qualified electrician.
- Do not touch the contacts on any of the sockets on the product. Replace damaged cords immediately.
- Unplug this product from wall outlets before cleaning.
- Do not install or use this product near water or when you are wet.
- Install the product securely on a stable surface.
- Install the product in a protected location where no one can step on or trip over the power cord.

## Printer views

Identify certain parts of the printer and the control panel.

- [Printer front view](#)
- [Printer back view](#)
- [Interface ports](#)
- [Control-panel view](#)

### Printer front view

Locate features on the front of the printer.

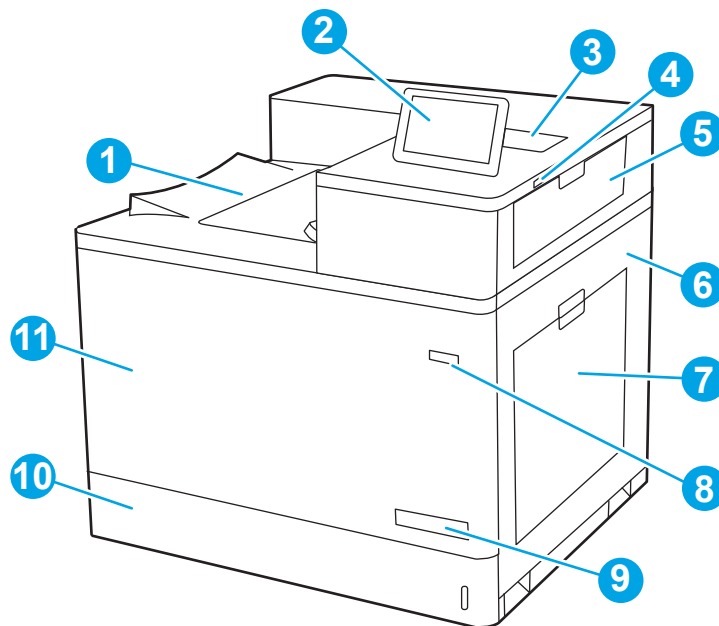

Number	Description
1	Output bin
2	Control panel
3	Hardware integration pocket for connecting accessory and third-party devices
4	Easy-access USB port Insert a USB flash drive for printing without a computer or to update the printer firmware. <b>NOTE:</b> An administrator must enable this port before use.
5	Upper-right door (access to clear jams)
6	Right door (access to the fuser and to clear jams)
7	Tray 1
8	On/off button
9	Model name

Number	Description
10	Tray 2
11	Front door (access to the toner cartridges, imaging drums, and waste toner collection unit)

## Printer back view

Locate features on the back of the printer.

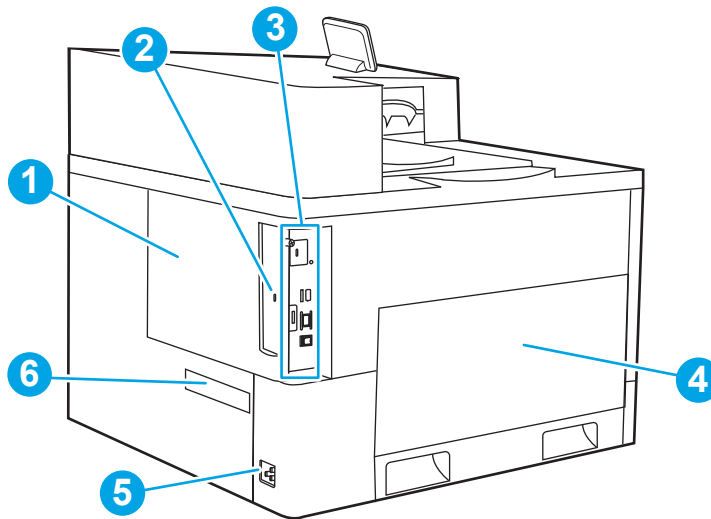

Number	Description
1	Formatter cover
2	Slot for a cable-type security lock
3	Formatter (contains the interface ports)
4	Left door (access to the toner-collection unit)
	<b>NOTE:</b> The front door also must be open in order to access the toner-collection unit.
5	Power connection
6	Serial number and product number label

## Interface ports

Locate the interface ports on the printer formatter.

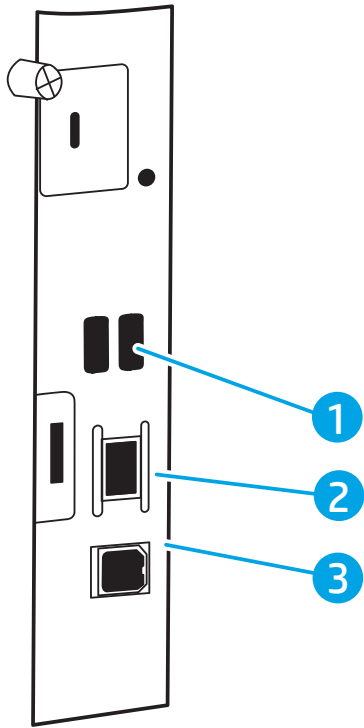

Number	Description
1	USB ports for connecting external USB devices (these ports might be covered) <b>NOTE:</b> For easy-access USB printing, use the USB port near the control panel.
2	Local area network (LAN) Ethernet 10/100/1000 network port
3	Hi-Speed USB 2.0 printing port



## Control-panel view

Use the touchscreen control panel to obtain printer and job status information and to configure the printer.

- [How to use the touchscreen control panel](#)

 **NOTE:** Tilt the control panel for easier viewing.





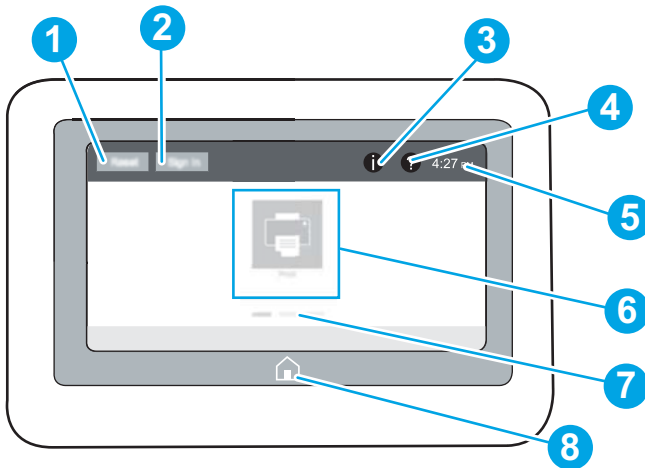

Return to the Home screen at any time by selecting the Home  button at the bottom of the printer control panel.

 **NOTE:** For more information about the printer-control-panel features, go to [www.hp.com/support/colorljE85055](http://www.hp.com/support/colorljE85055). Select **Manuals**, and then select **General reference**.

 **NOTE:** The features that appear on the Home screen can vary, depending on the printer configuration.



Number	Item	Description
1	<a href="#">Reset</a> button	Select the <a href="#">Reset</a> button to clear changes, release the printer from a paused state, display hidden errors, and restore the default settings (including the language and keyboard layout).
2	<a href="#">Sign In</a> or <a href="#">Sign Out</a> button	Select the <a href="#">Sign In</a> button to open the Sign In screen.  Select the <a href="#">Sign Out</a> button to sign out of the printer. The printer restores all options to the default settings.  <b>NOTE:</b> This button displays only if the administrator has configured the printer to require permission for access to features.

Number	Item	Description
3	Information  button	Select the Information  button to access a screen that provides access to several types of printer information. Select the buttons at the bottom of the screen for the following information: <ul style="list-style-type: none"> <li>• <a href="#">Display Language</a>: Change the language setting for the current user session.</li> <li>• <a href="#">Sleep Mode</a>: Place the printer into sleep mode.</li> <li>• <a href="#">Wi-Fi Direct</a>: View information for how to connect directly to the printer using a phone, tablet, or other device with Wi-Fi.</li> <li>• <a href="#">Wireless</a>: View or change wireless connection settings (some models require an optional wireless accessory).</li> <li>• <a href="#">Ethernet</a>: View or change Ethernet connection settings.</li> <li>• <a href="#">HP Web Services</a>: View information to connect and print to the printer using HP Web Services (ePrint).</li> </ul>
4	Help  button	Select the Help  button to open the embedded help system.  The system provides a list of help topics or information about a topic when using the Home screen, an app, an option, or a feature.
5	Current time	Displays the current time.
6	Applications area	Select any of the icons to open the application. Swipe the screen sideways to access more applications.  <b>NOTE:</b> The available applications vary by printer. The administrator can configure which applications appear and the order in which they appear.
7	Home-screen page indicator	Indicates the number of pages on the Home screen or in an application. The current page is highlighted. Swipe the screen sideways to scroll between pages.
8	Home  button	Select the Home  button to return to the Home screen.

## How to use the touchscreen control panel

Perform the following actions to use the printer touchscreen control panel.

**Table 1-1** Touchscreen control panel actions

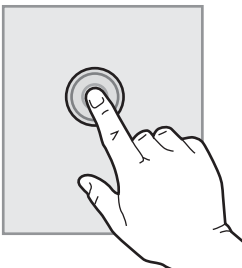
Action	Description	Example
Touch	Touch an item on the screen to select that item or open that menu. Also, when scrolling through menus, briefly touch the screen to stop the scrolling.	Touch the <a href="#">Settings</a> icon to open the <a href="#">Settings</a> app.
		

**Table 1-1** Touchscreen control panel actions (continued)

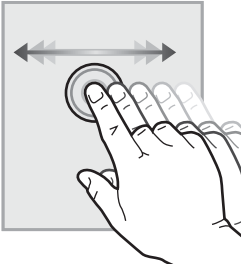
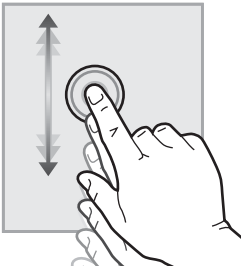
Action	Description	Example
Swipe	Touch the screen and then move your finger horizontally to scroll the screen sideways.	Swipe until the <a href="#">Settings</a> app displays.
		
Scroll	Touch the screen and then move your finger vertically to scroll the screen up and down. When scrolling through menus, briefly touch the screen to stop the scrolling.	Scroll through the <a href="#">Settings</a> app.
		

# Printer specifications

Determine the specifications for your printer model.

- [Technical specifications](#)
- [Supported operating systems](#)
- [Printer dimensions](#)
- [Power consumption, electrical specifications, and acoustic emissions](#)
- [Operating-environment range](#)



**IMPORTANT:** The following specifications are correct at the time of publication, but they are subject to change. For current information, see [www.hp.com/support/colorljE85055](http://www.hp.com/support/colorljE85055).

## Technical specifications

Review the printer technical specifications.

See [www.hp.com/support/colorljE85055](http://www.hp.com/support/colorljE85055) for current information.

### Product numbers for each model

- E85055dn - #T3U66A

**Table 1-2** Paper handling specifications

Paper handling features	E85055dn
Tray 1 (100-sheet capacity)	Included
Tray 2 (550-sheet capacity)	Included
550-sheet paper tray	Optional
<b>NOTE:</b> The E85055 models accept up to two optional 550-sheet trays.	
2 x 550-sheet paper tray and stand	Optional
<b>NOTE:</b> The E85055 models accept up to two optional 550-sheet trays that may be installed on top of the stand.	
2,700-sheet high-capacity input (HCI) paper tray and stand	Optional
<b>NOTE:</b> The E85055 models accept up to two optional 550-sheet trays that may be installed on top of the stand.	
Printer stand	Optional
<b>NOTE:</b> The E85055 models accept up to two optional 550-sheet trays that may be installed on top of the stand.	
Automatic duplex printing	Included

**Table 1-3** Connectivity specifications

Connectivity features	E85055dn
10/100/1000 Ethernet LAN connection with IPv4 and IPv6	Included

**Table 1-3 Connectivity specifications (continued)**

Connectivity features	E85055dn
Hi-Speed USB 2.0	Included
Easy-access USB port for printing from a USB flash drive or upgrading the firmware	Included
Hardware Integration Pocket for connecting accessory and third-party devices	Included
HP Internal USB Ports	Included
HP Jetdirect 2900nw Print Server accessory for Wi-Fi connectivity and an additional Ethernet port	Optional
HP Jetdirect 3100w accessory for Wi-Fi, BLE, NFC, and proximity badge reading	Optional

**Table 1-4 Print specifications**

Print features	E85055dn
Prints 55 pages per minute (ppm) on Letter-size paper and 56 ppm on A4-size paper	Included
Easy-access USB printing for printing from a USB flash drive	Included
Store jobs in the printer memory to print later or print privately	Included

**Table 1-5 Other specifications**

Other features	E85055dn
Memory: 1.5 GB base memory	Included
<b>NOTE:</b> Memory reported on configuration page will change from 1.5 GB to 2 GB with optional 1 GB SODIMM installed.	
Mass storage: 16 GB embedded Multi-Media Controller (eMMC)	Included
Security: HP Trusted Platform Module (TPM)	Included
Control panel: 4.3-inch color touchscreen	Included

## Supported operating systems

Use the following information to ensure printer compatibility with your computer operating system.

**Linux:** For information and print drivers for Linux, go to [www.hp.com/go/linuxprinting](http://www.hp.com/go/linuxprinting).

**UNIX:** For information and print drivers for UNIX®, go to [www.hp.com/go/unixmodelscripts](http://www.hp.com/go/unixmodelscripts).

The following information applies to the printer-specific Windows HP PCL 6 print drivers, HP print drivers for macOS, and to the software installer.

**Windows:** Download HP Easy Start from [123.hp.com/LaserJet](http://123.hp.com/LaserJet) to install the HP print driver. Or, go to the printer-support website for this printer: [www.hp.com/support/colorljE85055](http://www.hp.com/support/colorljE85055) to download the print driver or the software installer to install the HP print driver.

**macOS:** Mac computers are supported with this printer. Download HP Easy Start either from [123.hp.com/LaserJet](http://123.hp.com/LaserJet) or from the Printer Support page, and then use HP Easy Start to install the HP print driver.

1. Go to [123.hp.com/LaserJet](https://123.hp.com/LaserJet).
2. Follow the steps provided to download the printer software.

**Table 1-6 Supported operating systems and print drivers**

Operating system	Print driver (for Windows, or the installer on the web for macOS)
Windows 7, 32-bit and 64-bit	The “HP PCL 6” printer-specific print driver is installed for this operating system as part of the software installation.
Windows 8.1, 32-bit and 64-bit	The “HP PCL-6” V4 printer-specific print driver is installed for this operating system as part of the software installation.
Windows 10, 32-bit and 64-bit	The “HP PCL-6” V4 printer-specific print driver is installed for this operating system as part of the software installation.
Windows Server 2008 R2, SP 1, 64-bit	The PCL 6 printer-specific print driver is available for download from the printer-support website. Download the driver, and then use the Microsoft Add Printer tool to install it.
Windows Server 2012, 64-bit	The PCL 6 printer-specific print driver is available for download from the printer-support website. Download the driver, and then use the Microsoft Add Printer tool to install it.
Windows Server 2012 R2, 64-bit	The PCL 6 printer-specific print driver is available for download from the printer-support website. Download the driver, and then use the Microsoft Add Printer tool to install it.
Windows Server 2016, 64-bit	The PCL 6 printer-specific print driver is available for download from the printer-support website. Download the driver, and then use the Microsoft Add Printer tool to install it.
Windows Server 2019, 64-bit	The PCL 6 printer-specific print driver is available for download from the printer-support website. Download the driver, and then use the Microsoft Add Printer tool to install it.
macOS 10.13 High Sierra, macOS 10.14 Mojave	Download HP Easy Start from <a href="https://123.hp.com/LaserJet">123.hp.com/LaserJet</a> , and then use it to install the print driver.

 **NOTE:** Supported operating systems can change.

 **NOTE:** For a current list of supported operating systems and HP’s all-inclusive help for the printer, go to [www.hp.com/support/colorljE85055](https://www.hp.com/support/colorljE85055).

 **NOTE:** For details on client and server operating systems and for HP UPD driver support for this printer, go to [www.hp.com/go/upd](https://www.hp.com/go/upd). Under **Additional information**, click **Specifications**.

**Table 1-7 Minimum system requirements**

Windows	macOS
<ul style="list-style-type: none"> <li>• Internet connection</li> </ul>	<ul style="list-style-type: none"> <li>• Internet connection</li> </ul>
<ul style="list-style-type: none"> <li>• Dedicated USB 1.1 or 2.0 connection or a network connection</li> </ul>	<ul style="list-style-type: none"> <li>• Dedicated USB 1.1 or 2.0 connection or a network connection</li> </ul>
<ul style="list-style-type: none"> <li>• 2 GB of available hard-disk space</li> </ul>	<ul style="list-style-type: none"> <li>• 1.5 GB of available hard-disk space</li> </ul>
<ul style="list-style-type: none"> <li>• 1 GB RAM (32-bit) or 2 GB RAM (64-bit)</li> </ul>	



**NOTE:** The Windows software installer installs the HP Smart Device Agent Base service. The file size is less than 100 kb. Its only function is to check for printers connected via USB hourly. No data is collected. If a USB printer is found, it then tries to locate a JetAdvantage Management Connector (JAMc) instance on the network. If a JAMc is found, the HP Smart Device Agent Base is securely upgraded to a full Smart Device Agent from JAMc, which will then allow printed pages to be accounted for in a Managed Print Services (MPS) account. The driver-only web packs downloaded from [www.hp.com](http://www.hp.com) for the printer and installed through the Add Printer wizard do not install this service.

To uninstall the service, open the **Control Panel**, select **Programs** or **Programs and Features**, and then select **Add/Remove Programs** or **Uninstall a Program** to remove the service. The file name is **HPSmartDeviceAgentBase**.

## Printer dimensions

Make sure your printer environment is large enough to accommodate the printer.

**Table 1-8** Dimensions for the base printer—E85055dn

Dimension	Printer fully closed	Printer fully opened
Height	520 mm (20.5 in)	592 mm (23.3 in)
Depth	610 mm (24.0 in)	1018 mm (40.1 in)
Width	556 mm (21.9 in)	1051 mm (41.4 in)
Weight (with toner cartridges)	52.3 kg (115.3 lb)	52.3 kg (115.3 lb)

**Table 1-9** Dimensions for the 550-sheet paper tray

Dimension	Accessory fully closed	Accessory fully open
Height	150 mm (5.9 in) (includes alignment pins)	150 mm (5.9 in) (includes alignment pins)
Depth	584 mm (23 in)	1003 mm (39.5 in)
Width	556 mm (21.9 in)	640 mm (25.2 in)
Weight	10.2 kg (22.5 lb)	10.2 kg (22.5 lb)

**Table 1-10** Dimensions for the printer with one 550-sheet paper tray

Dimension	Printer fully closed	Printer fully opened
Height	646 mm (25.4 in)	718 mm (28.3 in)
Depth	610 mm (24.0 in)	1034 mm (40.7 in)
Width	556 mm (21.9 in)	1051 mm (41.4 in)
Weight	62.5 kg (137.8 lb)	62.5 kg (137.8 lb)

**Table 1-11** Dimensions for the 2 x 550-sheet paper tray and stand

Dimension	Accessory fully closed	Accessory fully open
Height	347 mm (13.7 in) (includes alignment pins)	347 mm (13.7 in) (includes alignment pins)
Depth <sup>1</sup>	659 mm (25.9 in)	1074 mm (42.3 in)
Width <sup>1</sup>	556 mm (21.9 in)	771 mm (30.4 in)
Weight <sup>1</sup>	22.9 kg (50.5 lb)	22.9 kg (50.5 lb)

<sup>1</sup> Does not include stability feet.

**Table 1-12** Dimensions for the printer with the 2 x 550-sheet paper tray and stand

Dimension	Printer and accessories fully closed	Printer and accessories fully opened
Height	844 mm (33.2 in)	916 mm (36.1 in)
Depth <sup>1</sup>	659 mm (25.9 in)	1074 mm (42.3 in)
Width <sup>1</sup>	556 mm (21.9 in)	1051 mm (41.4 in)
Weight <sup>1</sup>	75.2 kg (165.8 lb)	75.2 kg (165.8 lb)

<sup>1</sup> Does not include stability feet.

**Table 1-13** Dimensions for the high-capacity input paper tray and stand

Dimension	Accessory fully closed	Accessory fully open
Height	347 mm (13.7 in)	347 mm (13.7 in)
Depth <sup>1</sup>	659 mm (25.9 in)	1064 mm (41.9 in)
Width <sup>1</sup>	556 mm (21.9 in)	Door open: 771 mm (30.4 in)
Weight <sup>1</sup>	28.2 kg (62.2 lb)	28.2 kg (62.2 lb)

<sup>1</sup> Does not include stability feet.

**Table 1-14** Dimensions for the printer with the high-capacity input paper tray and stand

Dimension	Printer and accessories fully closed	Printer and accessories fully opened
Height	844 mm (33.2 in)	916 mm (36.1 in)
Depth <sup>1</sup>	663 mm (26.1 in)	1064 mm (41.9 in)
Width <sup>1</sup>	585 mm (23 in)	1051 mm (41.4 in)
Weight <sup>1</sup>	80.5 kg (177.5 lb)	80.5 kg (177.5 lb)

<sup>1</sup> Does not include stability feet.

**Table 1-15** Dimensions for the stand

Dimension	Accessory fully closed	Accessory fully open
Height	347 mm (13.7 in)	347 mm (13.7 in)



**Table 1-15** Dimensions for the stand (continued)

Dimension	Accessory fully closed	Accessory fully open
Depth <sup>1</sup>	659 mm (25.9 in)	1185 mm (46.7 in)
Width <sup>1</sup>	556 mm (21.9 in)	556 mm (21.9 in)
Weight <sup>1</sup>	19 kg (41.9 lb)	19 kg (41.9 lb)

<sup>1</sup> Does not include stability feet.

**Table 1-16** Dimensions for the printer with the stand

	Printer and accessories fully closed	Printer and accessories fully opened
Height	844 mm (33.2 in)	916 mm (36.1 in)
Depth <sup>1</sup>	659 mm (25.9 in)	1185 mm (46.7 in)
Width <sup>1</sup>	556 mm (21.9 in)	1051 mm (41.4 in)
Weight <sup>1</sup>	68.1 kg (150.2 lb)	68.1 kg (150.2 lb)

<sup>1</sup> Does not include stability feet.

## Power consumption, electrical specifications, and acoustic emissions

In order to operate properly, the printer must be in an environment that meets certain power specifications.

See [www.hp.com/support/colorljE85055](http://www.hp.com/support/colorljE85055) for current information.

**CAUTION:** Power requirements are based on the country/region where the printer is sold. Do not convert operating voltages. This will damage the printer and void the printer warranty.

## Operating-environment range

In order to operate properly, the printer must be in an environment that meets certain specifications.

**Table 1-17** Operating-environment specifications

Environment	Recommended	Allowed
Temperature	15° to 27°C (59° to 80.6°F)	10° to 32.5°C (50° to 90.5°F)
Relative humidity	30% to 70% relative humidity (RH)	10% to 80% RH

## Printer hardware setup and software installation

For basic setup instructions, see the Hardware Installation Guide that came with the printer. For additional instructions, go to HP support on the web.

Go to [www.hp.com/support/colorljE85055](http://www.hp.com/support/colorljE85055) for HP's all-inclusive help for the printer, which includes the following information:

- Install and configure
- Learn and use

- Solve problems
- Download software and firmware updates
- Join support forums
- Find warranty and regulatory information
- Find instructions about how to use the Microsoft Add Printer tool

---

## 2 Paper trays

Discover how to load and use the paper trays, including how to load special items such as envelopes and labels.

- [Introduction](#)
- [Load paper to Tray 1 \(multipurpose tray\)](#)
- [Load paper to Tray 2](#)
- [Load paper to the 550-sheet paper tray](#)
- [Load paper to the 2 x 550-sheet paper trays](#)
- [Load paper to the 2,700-sheet high-capacity input paper trays](#)
- [Load and print envelopes](#)
- [Load and print labels](#)

For video assistance, see [www.hp.com/videos/LaserJet](http://www.hp.com/videos/LaserJet).

The following information is correct at the time of publication. For current information, see [www.hp.com/support/colorljE85055](http://www.hp.com/support/colorljE85055).

### For more information:

HP's all-inclusive help for the printer includes the following information:

- Install and configure
- Learn and use
- Solve problems
- Download software and firmware updates
- Join support forums
- Find warranty and regulatory information

## Introduction

Use caution when loading the paper trays.

---

 **CAUTION:** Do not extend more than one paper tray at a time.

Do not use paper tray as a step.

Keep hands out of paper trays when closing.

All trays must be closed when moving the printer.

---

## Load paper to Tray 1 (multipurpose tray)

The following information describes how to load paper into Tray 1.

- [Load Tray 1 \(multipurpose tray\)](#)
- [Tray 1 paper orientation](#)
- [Use alternative letterhead mode](#)

### Load Tray 1 (multipurpose tray)

Use the following process to load paper into Tray 1.

1. Open Tray 1.

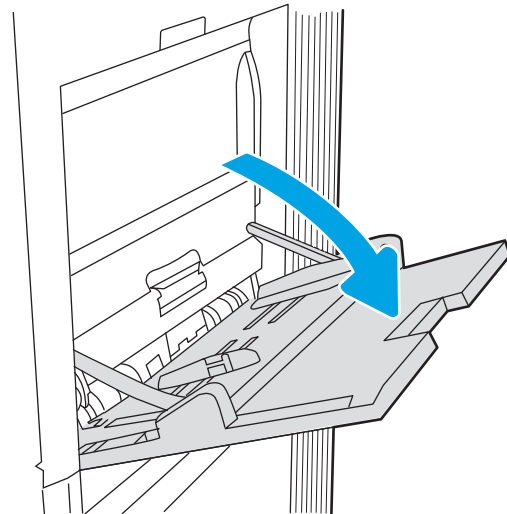

2. Pull out the tray extension to support the paper.

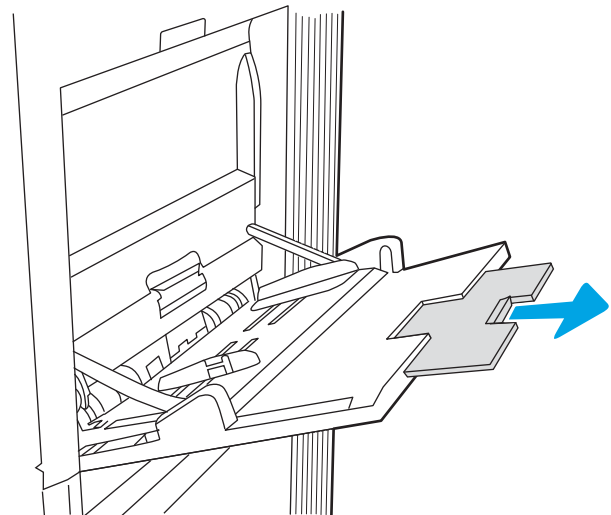

- Use the blue adjustment latch to spread the paper guides to the correct size, and then load paper in the tray. For information about how to orient the paper, see [Tray 1 paper orientation on page 20](#).

Make sure that the paper fits under the fill line on the paper guides.

**NOTE:** The maximum stack height is 10 mm (0.4 in), or approximately 100 sheets of 75 g/m<sup>2</sup> (20 lb) paper.

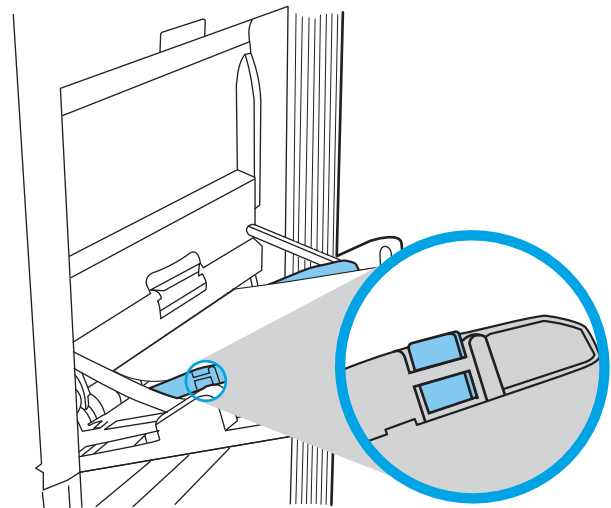

- Using the blue adjustment latch, adjust the side guides so that they lightly touch the paper stack, but do not bend it.

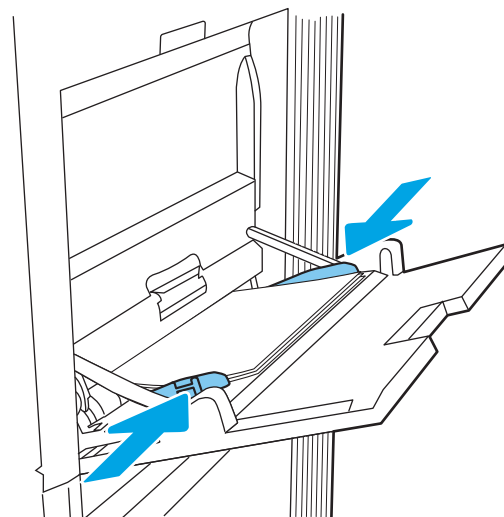

## Tray 1 paper orientation

Position paper correctly in Tray 1 to ensure the best print quality.

**Table 2-1** Letterhead or preprinted—portrait

Duplex mode	Paper size	How to load paper
1-sided printing	12x18, 11x17, RA3, SRA3, A3, 8K (273x394 mm), 8K (270x390 mm), 8K (260x368 mm), B4 (JIS), Legal, Oficio (8.5x13), Oficio (216x340 mm), SRA4, RA4, A4, Letter	Face-down Bottom edge leading into the printer

**Table 2-1 Letterhead or preprinted—portrait (continued)**

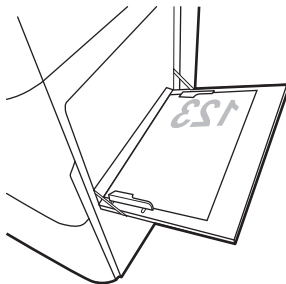
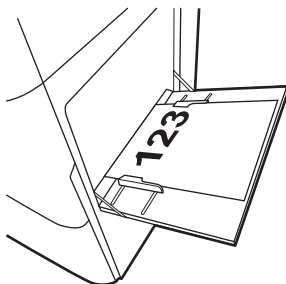
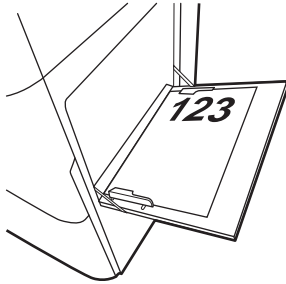
Duplex mode	Paper size	How to load paper
1-sided printing	A4, Letter, Executive, A5, 16K (197x273 mm) 16K (195x270 mm), 16K (184x260 mm), B5 (JIS), Double Japan Postcard (148x200 mm)	<p>Face-down</p> <p>Left side of pre-printed image leading into the printer</p> <p><b>NOTE:</b> This is the preferred orientation when printing on A4 or Letter.</p> 
Automatic 2-sided printing or with Alternative Letterhead Mode enabled	12x18, 11x17, RA3, SRA3, A3, 8K (273x394 mm), 8K (270x390 mm), 8K (260x368 mm), B4 (JIS), Legal, Oficio (8.5x13), Oficio (216x340 mm), SRA4, RA4, A4, Letter	<p>Face-up</p> <p>Top edge leading into the printer</p> 
Automatic 2-sided printing or with Alternative Letterhead Mode enabled	A4, Letter, Executive, A5, 16K (197x273 mm) 16K (195x270 mm), 16K (184x260 mm), B5 (JIS), Double Japan Postcard (148x200 mm)	<p>Face-up</p> <p>Right side of pre-printed image leading into the printer</p> <p><b>NOTE:</b> This is the preferred orientation when printing on A4 or Letter.</p> 

**Table 2-2 Letterhead or preprinted—landscape**

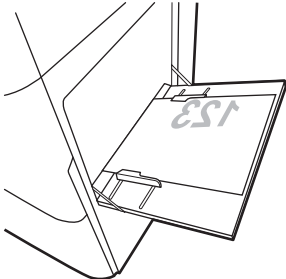
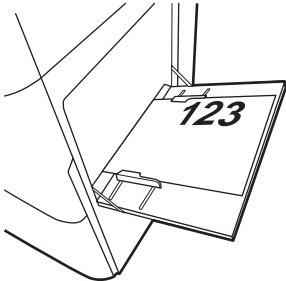
Duplex mode	Paper size	How to load paper
1-sided printing	12x18, 11x17, RA3, SRA3, A3, 8K (273x394 mm), 8K (270x390 mm), 8K (260x368 mm), B4 (JIS), Legal, Oficio (8.5x13), Oficio (216x340 mm), SRA4, RA4, A4, Letter	<p>Face-down</p> <p>Left side of pre-printed image leading into the printer</p> 
Automatic 2-sided printing or with Alternative Letterhead Mode enabled	12x18, 11x17, RA3, SRA3, A3, 8K (273x394 mm), 8K (270x390 mm), 8K (260x368 mm), B4 (JIS), Legal, Oficio (8.5x13), Oficio (216x340 mm), SRA4, RA4, A4, Letter	<p>Face-up</p> <p>Right side of the pre-printed image leading into the printer</p> 



**Table 2-2 Letterhead or preprinted—landscape (continued)**

Duplex mode	Paper size	How to load paper
1-sided printing	A4, Letter, Executive, A5, 16K (197x273 mm) 16K (195x270 mm), 16K (184x260 mm), B5 (JIS), Double Japan Postcard (148x200 mm)	<p>Face-down</p> <p>Bottom edge leading into the printer</p> <p><b>NOTE:</b> This is the preferred orientation when printing on A4 or Letter.</p>
Automatic 2-sided printing or with Alternative Letterhead Mode enabled	A4, Letter, Executive, A5, 16K (197x273 mm) 16K (195x270 mm), 16K (184x260 mm), B5 (JIS), Double Japan Postcard (148x200 mm)	<p>Face-up</p> <p>Top edge leading into the printer</p> <p><b>NOTE:</b> This is the preferred orientation when printing on A4 or Letter.</p>

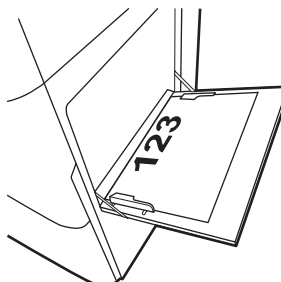
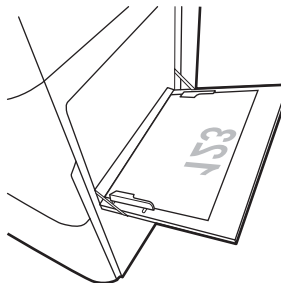

**Table 2-3** Prepunched—portrait

Duplex mode	Paper size	How to load paper
1-sided printing	12x18, 11x17, RA3, SRA3, A3, 8K (273x394 mm), 8K (270x390 mm), 8K (260x368 mm), B4 (JIS), Legal, Oficio (8.5x13), Oficio (216x340 mm), SRA4, RA4, A4, Letter	Face-down Holes toward the back of the printer 
Automatic 2-sided printing or with Alternative Letterhead Mode enabled	12x18, 11x17, RA3, SRA3, A3, 8K (273x394 mm), 8K (270x390 mm), 8K (260x368 mm), B4 (JIS), Legal, Oficio (8.5x13), Oficio (216x340 mm), SRA4, RA4, A4, Letter	Face-up Holes toward the back of the printer 

Table 2-4 Prepunched—landscape

Duplex mode	Paper size	How to load paper
1-sided printing	A4, Letter, Executive, A5, 16K (197x273 mm) 16K (195x270 mm), 16K (184x260 mm), B5 (JIS), Double Japan Postcard (148x200 mm)	Face-down Holes away from the printer <b>NOTE:</b> This is the preferred orientation when printing on A4 or Letter. 
Automatic 2-sided printing or with Alternative Letterhead Mode enabled	A4, Letter, Executive, A5, 16K (197x273 mm) 16K (195x270 mm), 16K (184x260 mm), B5 (JIS), Double Japan Postcard (148x200 mm)	Face-up Holes towards the printer <b>NOTE:</b> This is the preferred orientation when printing on A4 or Letter. 

## Use alternative letterhead mode

Use the [Alternative Letterhead Mode](#) feature to load letterhead or preprinted paper into the tray the same way for all jobs, whether printing to one side of the sheet of paper or to both sides. When using this mode, load paper as for automatic duplex printing.

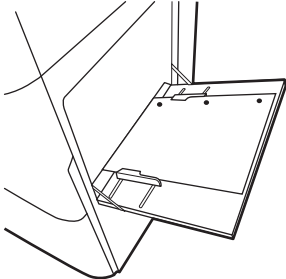
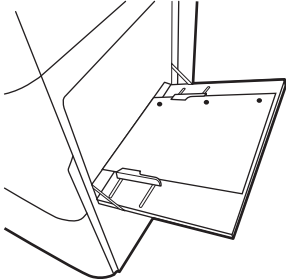
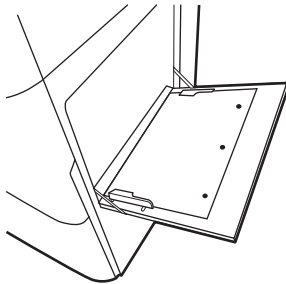
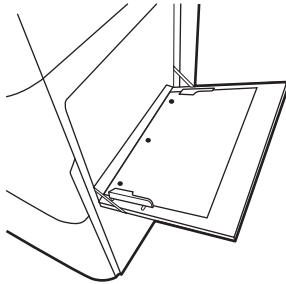
- [Enable Alternative Letterhead Mode by using the printer control-panel menus](#)

### Enable Alternative Letterhead Mode by using the printer control-panel menus

Use the [Settings](#) menu to set the [Alternative Letterhead Mode](#) setting.

1. From the Home screen on the printer control panel, navigate to and open the [Settings](#) menu.
2. Open the following menus:
  - a. [Copy/Print](#) or [Print](#)
  - b. [Manage Trays](#)
  - c. [Alternative Letterhead Mode](#)
3. Select [On](#).

## Load paper to Tray 2

The following information describes how to load paper into Tray 2.

- [Load Tray 2](#)
- [Tray 2 paper orientation](#)
- [Use alternative letterhead mode](#)

### Load Tray 2

Use the following process to load paper into Tray 2.

 **NOTE:** The tray paper guides might be locked before use and might not be adjustable.

1. Open the tray.

**NOTE:** Do not open this tray while the printer is printing.

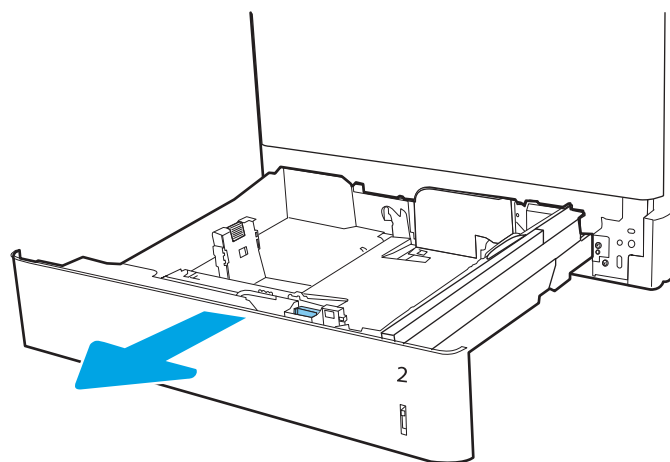

2. Before loading paper, adjust the paper-width guides by squeezing the blue adjustment latches and sliding the guides to the size of the paper being used.

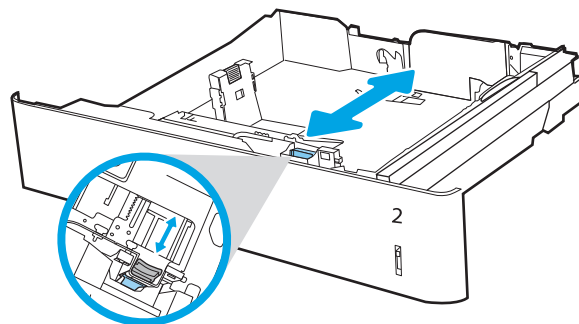

3. Adjust the paper-length guide by squeezing the adjustment latch and sliding the guide to the size of the paper being used.

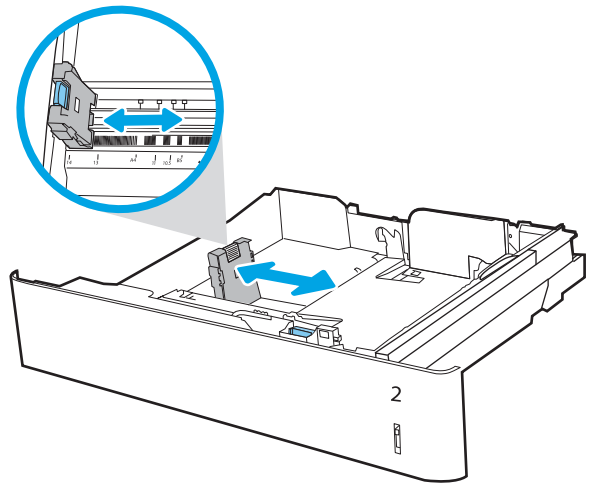

4. Load paper into the tray. For information about how to orient the paper, see [Tray 2 paper orientation on page 29](#).

**NOTE:** To prevent jams, do not overfill the tray. Be sure that the top of the stack is below the tray full indicator.

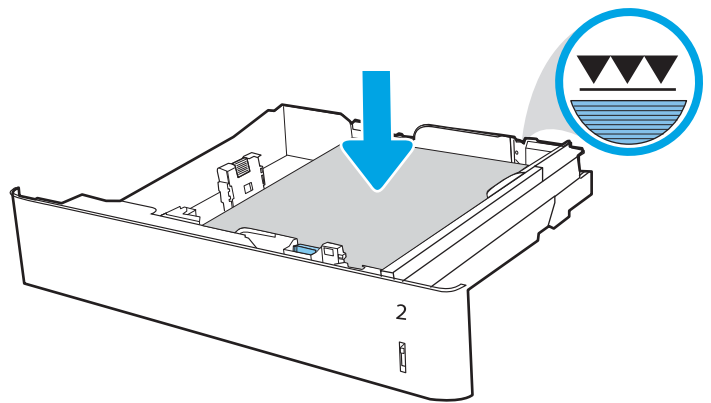

5. Check the paper to verify the guides lightly touch the stack, but do not bend it.

**NOTE:** Do not adjust the paper guides tightly against the paper stack. Adjust them to the indentations or markings in the tray.

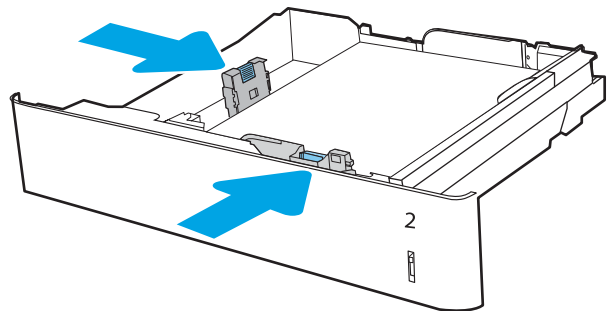

6. Close the tray.

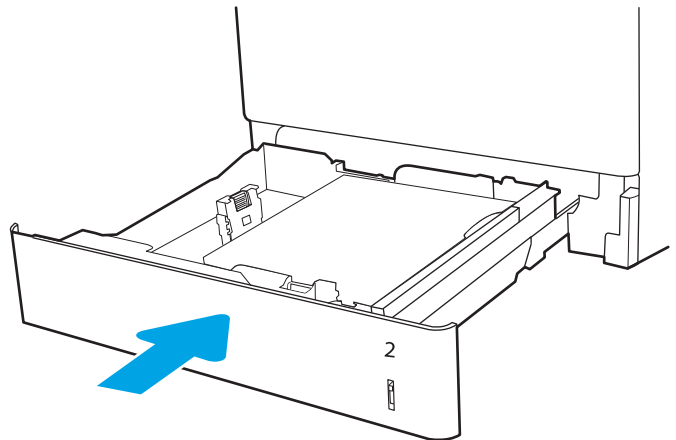

7. The tray configuration message displays on the printer control panel.
8. Press the **OK** button to accept the detected type and size, or select **Modify** to choose a different paper size or type.

For custom-size paper, specify the **X** and **Y** dimensions for the paper when the prompt displays on the printer control panel.

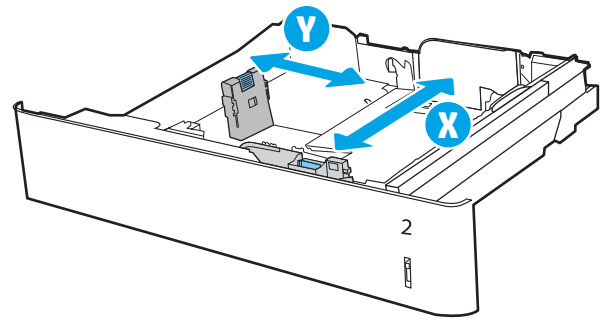

## Tray 2 paper orientation

Position paper correctly in Tray 2 to ensure the best print quality.

**Table 2-5** Letterhead or preprinted—portrait

Duplex mode	Paper size	How to load paper
1-sided printing	A4, Letter, 16K (197x273 mm) 16K (195x270 mm), Executive, A5, 16K (184x260 mm), B5 (JIS), Double Japan Postcard (148x200 mm)	Face-up Top edge at the back of the tray  <b>NOTE:</b> This is the preferred orientation when printing on A4 or Letter.
1-sided printing	11x17, A3, 8K (273x397 mm), 8K (270x390 mm), 8K (260x368 mm), B4 (JIS), Legal, Oficio (8.5x13), Oficio (216x340 mm), SRA4, RA4, A4, Letter	Face-up Top edge at the right side of the tray

**Table 2-5 Letterhead or preprinted—portrait (continued)**

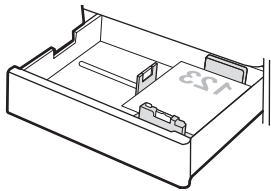
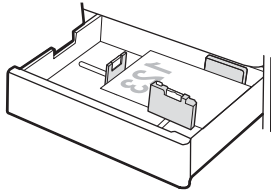
Duplex mode	Paper size	How to load paper
Automatic 2-sided printing or with Alternative Letterhead Mode enabled	A4, Letter, 16K (197x273 mm) 16K (195x270 mm), Executive, A5, 16K (184x260 mm), B5 (JIS), Double Japan Postcard (148x200 mm)	<p>Face-down</p> <p>Top edge at the back of the tray</p> <p><b>NOTE:</b> This is the preferred orientation when printing on A4 or Letter.</p> 
Automatic 2-sided printing or with Alternative Letterhead Mode enabled	11x17, A3, 8K (273x397 mm), 8K (270x390 mm), 8K (260x368 mm), B4 (JIS), Legal, Oficio (8.5x13), Oficio (216x340 mm), SRA4, RA4, A4, Letter	<p>Face-down</p> <p>Top edge at the left side of the tray</p> 

**Table 2-6 Letterhead or preprinted—landscape**

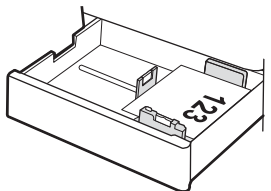
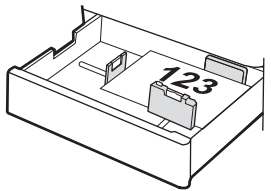
Duplex mode	Paper size	How to load paper
1-sided printing	A4, Letter, 16K (197x273 mm) 16K (195x270 mm), Executive, A5, 16K (184x260 mm), B5 (JIS), Double Japan Postcard (148x200 mm)	<p>Face-up</p> <p>Top edge at the right side of the tray</p> <p><b>NOTE:</b> This is the preferred orientation when printing on A4 or Letter.</p> 
1-sided printing	11x17, A3, 8K (273x397 mm), 8K (270x390 mm), 8K (260x368 mm), B4 (JIS), Legal, Oficio (8.5x13), Oficio (216x340 mm), SRA4, RA4, A4, Letter	<p>Face-up</p> <p>Top edge at the back of the tray</p> 

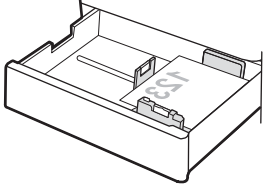
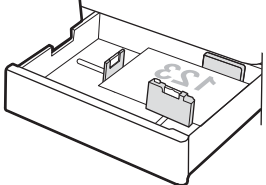

**Table 2-6 Letterhead or preprinted—landscape (continued)**

Duplex mode	Paper size	How to load paper
Automatic 2-sided printing or with Alternative Letterhead Mode enabled	A4, Letter, 16K (197x273 mm) 16K (195x270 mm), Executive, A5, 16K (184x260 mm), B5 (JIS), Double Japan Postcard (148x200 mm)	<p>Face-down</p> <p>Top edge at the left side of the tray</p> <p><b>NOTE:</b> This is the preferred orientation when printing on A4 or Letter.</p> 
Automatic 2-sided printing or with Alternative Letterhead Mode enabled	11x17, A3, 8K (273x397 mm), 8K (270x390 mm), 8K (260x368 mm), B4 (JIS), Legal, Oficio (8.5x13), Oficio (216x340 mm), SRA4, RA4, A4, Letter	<p>Face-down</p> <p>Top edge at the back of the tray</p> 

**Table 2-7 Prepunched—portrait**

Duplex mode	Paper size	How to load paper
1-sided printing	A4, Letter, 16K (197x273 mm) 16K (195x270 mm), Executive, A5, 16K (184x260 mm), B5 (JIS), Double Japan Postcard (148x200 mm)	<p>Face-up</p> <p>Holes at the left side of the tray, with the top of the form at the rear of the printer</p> <p><b>NOTE:</b> This is the preferred orientation when printing on A4 or Letter.</p> 
1-sided printing	11x17, A3, 8K (273x397 mm), 8K (270x390 mm), 8K (260x368 mm), B4 (JIS), Legal, Oficio (8.5x13), Oficio (216x340 mm), SRA4, RA4, A4, Letter	<p>Face-up</p> <p>Holes at the back of the tray</p> 

Table 2-7 Prepunched—portrait (continued)

Duplex mode	Paper size	How to load paper
Automatic 2-sided printing or with Alternative Letterhead Mode enabled	A4, Letter, 16K (197x273 mm) 16K (195x270 mm), Executive, A5, 16K (184x260 mm), B5 (JIS), Double Japan Postcard (148x200 mm)	Face-down Holes at the right side of the tray  <b>NOTE:</b> This is the preferred orientation when printing on A4 or Letter.  
Automatic 2-sided printing or with Alternative Letterhead Mode enabled	11x17, A3, 8K (273x397 mm), 8K (270x390 mm), 8K (260x368 mm), B4 (JIS), Legal, Oficio (8.5x13), Oficio (216x340 mm), SRA4, RA4, A4, Letter	Face-down Holes at the back of the tray  

## Use alternative letterhead mode

Use the [Alternative Letterhead Mode](#) feature to load letterhead or preprinted paper into the tray the same way for all jobs, whether printing to one side of the sheet of paper or to both sides. When using this mode, load paper as for automatic duplex printing.

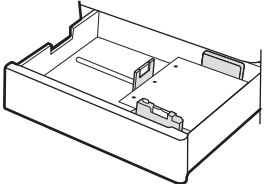
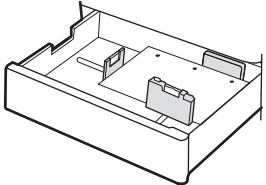
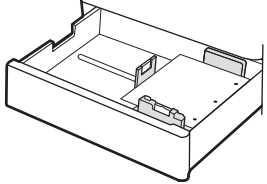
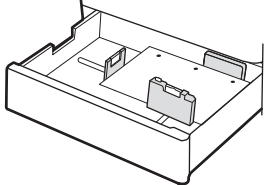
- [Enable Alternative Letterhead Mode by using the printer control-panel menus](#)

### Enable Alternative Letterhead Mode by using the printer control-panel menus

Use the [Settings](#) menu to set the [Alternative Letterhead Mode](#) setting.

1. From the Home screen on the printer control panel, navigate to and open the [Settings](#) menu.
2. Open the following menus:
  - a. [Copy/Print or Print](#)
  - b. [Manage Trays](#)
  - c. [Alternative Letterhead Mode](#)
3. Select [On](#).

# Load paper to the 550-sheet paper tray

The following information describes how to load paper into the 550-sheet paper tray.

- [Load paper to the 550-sheet paper tray](#)
- [550-sheet paper tray paper orientation](#)
- [Use alternative letterhead mode](#)

## Load paper to the 550-sheet paper tray

Use the following process to load paper into the 550-sheet paper tray.

1. Open the tray.

**NOTE:** Do not open this tray while the printer is printing.

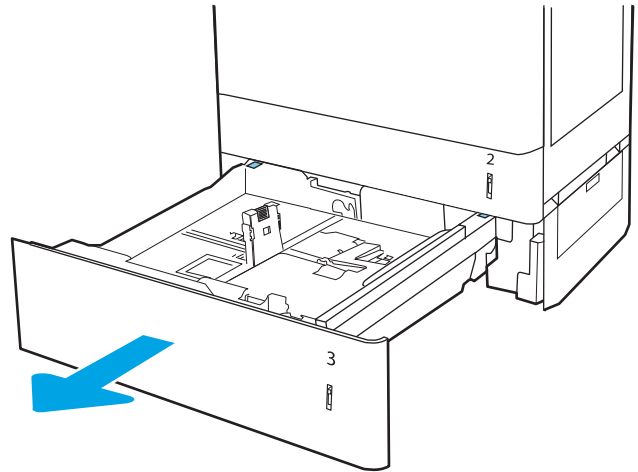

2. Before loading paper, adjust the paper-width guides by squeezing the blue adjustment latches and sliding the guides to the size of the paper being used.

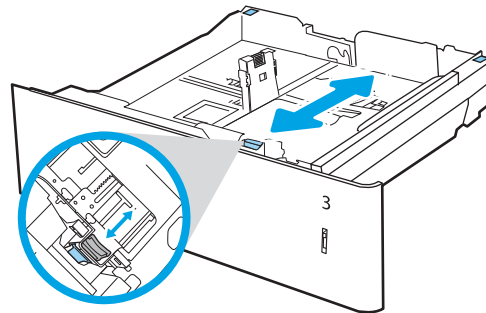

3. Adjust the paper-length guide by squeezing the adjustment latch and sliding the guide to the size of the paper being used.

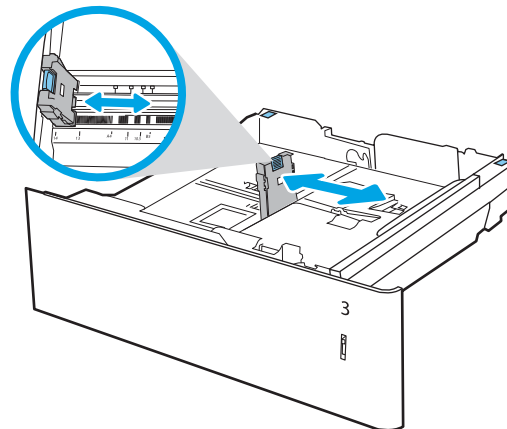

4. For any of the following paper sizes, also adjust the blue paper-stop lever in the left rear corner of the tray to the correct position, as indicated by the label in the tray:

- 12 x 18
- RA3
- 11 x 17
- A3
- SRA3

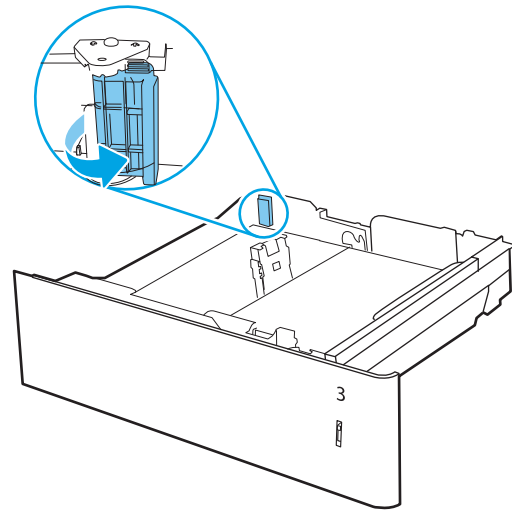

5. Load paper into the tray. For information about how to orient the paper, see [550-sheet paper tray paper orientation on page 36](#).

**NOTE:** To prevent jams, do not overfill the tray. Be sure that the top of the stack is below the tray full indicator.

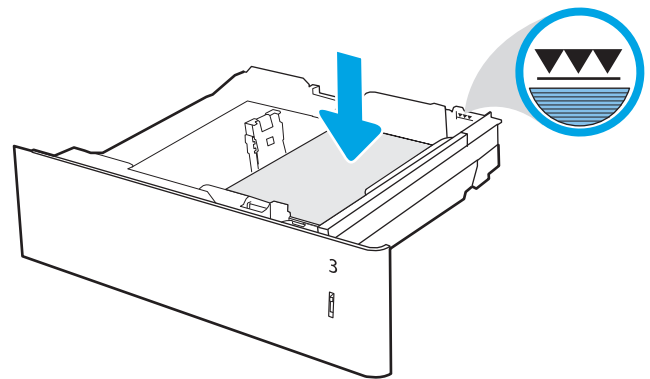

6. Check the paper to verify the guides lightly touch the stack, but do not bend it.

**NOTE:** Do not adjust the paper guides tightly against the paper stack. Adjust them to the indentations or markings in the tray.

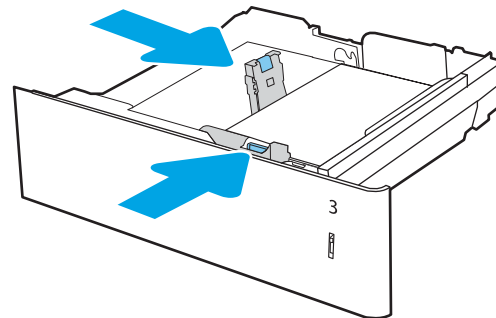

7. Close the tray.

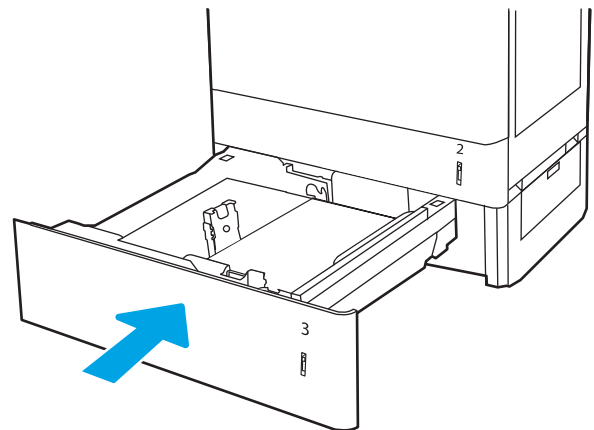

8. The tray configuration message displays on the printer control panel.
9. Press the **OK** button to accept the detected type and size, or select **Modify** to choose a different paper size or type.

For custom-size paper, specify the **X** and **Y** dimensions for the paper when the prompt displays on the printer control panel.

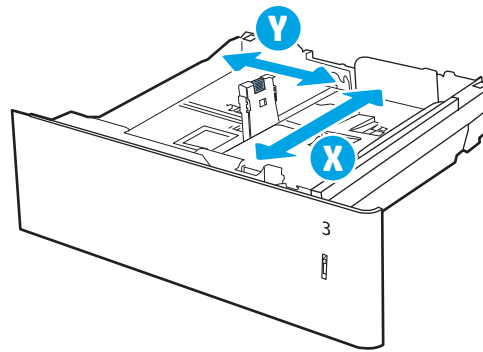

## 550-sheet paper tray paper orientation

Position paper correctly in the 550-sheet tray to ensure the best print quality.

**Table 2-8** Letterhead or preprinted—portrait

Duplex mode	Paper size	How to load paper
1-sided printing	A4, Letter, 16K (197x273 mm) 16K (195x270 mm), Executive, A5, 16K (184x260 mm), B5 (JIS), Double Japan Postcard (148x200 mm)	Face-up Top edge at the back of the tray  <b>NOTE:</b> This is the preferred orientation when printing on A4 or Letter.
1-sided printing	12x18, 11x17, A3, 8K (273x397 mm), 8K (270x390 mm), 8K (260x368 mm), B4 (JIS), Legal, Oficio (8.5x13), Oficio (216x340 mm), SRA3, RA3, SRA4, RA4, A4, Letter	Face-up Top edge at the right side of the tray

**Table 2-8 Letterhead or preprinted—portrait (continued)**

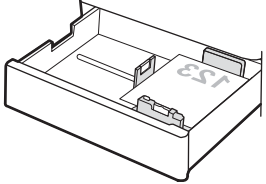
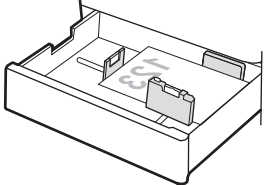
Duplex mode	Paper size	How to load paper
Automatic 2-sided printing or with Alternative Letterhead Mode enabled	A4, Letter, 16K (197x273 mm) 16K (195x270 mm), Executive, A5, 16K (184x260 mm), B5 (JIS), Double Japan Postcard (148x200 mm)	<p>Face-down</p> <p>Top edge at the back of the tray</p> <p><b>NOTE:</b> This is the preferred orientation when printing on A4 or Letter.</p> 
Automatic 2-sided printing or with Alternative Letterhead Mode enabled	12x18, 11x17, A3, 8K (273x397 mm), 8K (270x390 mm), 8K (260x368 mm), B4 (JIS), Legal, Oficio (8.5x13), Oficio (216x340 mm), SRA3, RA3, SRA4, RA4, A4, Letter	<p>Face-down</p> <p>Top edge at the left side of the tray</p> 

**Table 2-9 Letterhead or preprinted—landscape**

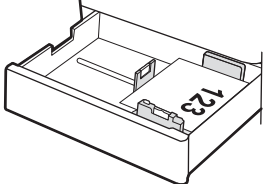
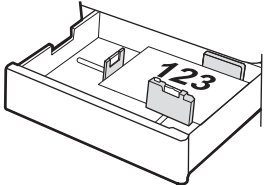
Duplex mode	Paper size	How to load paper
1-sided printing	A4, Letter, 16K (197x273 mm) 16K (195x270 mm), Executive, A5, 16K (184x260 mm), B5 (JIS), Double Japan Postcard (148x200 mm)	<p>Face-up</p> <p>Top edge at the right side of the tray</p> <p><b>NOTE:</b> This is the preferred orientation when printing on A4 or Letter.</p> 
1-sided printing	12x18, 11x17, A3, 8K (273x397 mm), 8K (270x390 mm), 8K (260x368 mm), B4 (JIS), Legal, Oficio (8.5x13), Oficio (216x340 mm), SRA3, RA3, SRA4, RA4, A4, Letter	<p>Face-up</p> <p>Top edge at the back of the tray</p> 

**Table 2-9 Letterhead or preprinted—landscape (continued)**

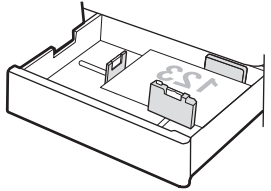
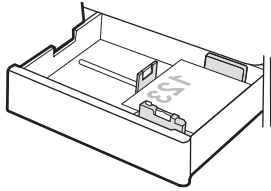
Duplex mode	Paper size	How to load paper
Automatic 2-sided printing or with Alternative Letterhead Mode enabled	12x18, 11x17, A3, 8K (273x397 mm), 8K (270x390 mm), 8K (260x368 mm), B4 (JIS), Legal, Oficio (8.5x13), Oficio (216x340 mm), SRA3, RA3, SRA4, RA4, A4, Letter	Face-down Top edge at the back of the tray 
Automatic 2-sided printing or with Alternative Letterhead Mode enabled	A4, Letter, 16K (197x273 mm) 16K (195x270 mm), Executive, A5, 16K (184x260 mm), B5 (JIS), Double Japan Postcard (148x200 mm)	Face-down Top edge at the left side of the tray <b>NOTE:</b> This is the preferred orientation when printing on A4 or Letter. 

**Table 2-10 Prepunched—portrait**

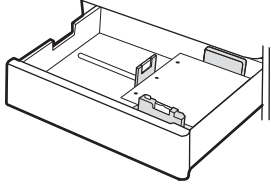
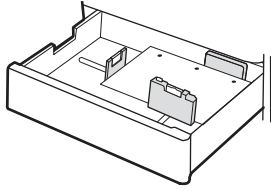
Duplex mode	Paper size	How to load paper
1-sided printing	A4, Letter, 16K (197x273 mm) 16K (195x270 mm), Executive, A5, 16K (184x260 mm), B5 (JIS), Double Japan Postcard (148x200 mm)	Face-up Holes at the left side of the tray, with the top of the form at the rear of the printer <b>NOTE:</b> This is the preferred orientation when printing on A4 or Letter. 
1-sided printing	12x18, 11x17, A3, 8K (273x397 mm), 8K (270x390 mm), 8K (260x368 mm), B4 (JIS), Legal, Oficio (8.5x13), Oficio (216x340 mm), SRA3, RA3, SRA4, RA4, A4, Letter	Face-up Holes at the back of the tray 



**Table 2-10** Prepunched—portrait (continued)

Duplex mode	Paper size	How to load paper
Automatic 2-sided printing or with Alternative Letterhead Mode enabled	A4, Letter, 16K (197x273 mm) 16K (195x270 mm), Executive, A5, 16K (184x260 mm), B5 (JIS), Double Japan Postcard (148x200 mm)	<p>Face-down</p> <p>Holes at the right side of the tray</p> <p><b>NOTE:</b> This is the preferred orientation when printing on A4 or Letter.</p>
Automatic 2-sided printing or with Alternative Letterhead Mode enabled	12x18, 11x17, A3, 8K (273x397 mm), 8K (270x390 mm), 8K (260x368 mm), B4 (JIS), Legal, Oficio (8.5x13), Oficio (216x340 mm), SRA3, RA3, SRA4, RA4, A4, Letter	<p>Face-down</p> <p>Holes at the back of the tray</p>

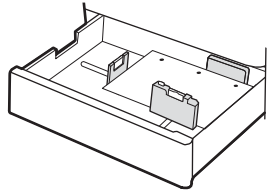
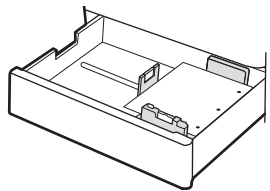

## Use alternative letterhead mode

Use the [Alternative Letterhead Mode](#) feature to load letterhead or preprinted paper into the tray the same way for all jobs, whether printing to one side of the sheet of paper or to both sides. When using this mode, load paper as for automatic duplex printing.

- [Enable Alternative Letterhead Mode by using the printer control-panel menus](#)

### Enable Alternative Letterhead Mode by using the printer control-panel menus

Use the [Settings](#) menu to set the [Alternative Letterhead Mode](#) setting.

1. From the Home screen on the printer control panel, navigate to and open the [Settings](#) menu.
2. Open the following menus:
  - a. [Copy/Print](#) or [Print](#)
  - b. [Manage Trays](#)
  - c. [Alternative Letterhead Mode](#)
3. Select [On](#).

# Load paper to the 2 x 550-sheet paper trays

The following information describes how to load paper into the 2 x 550-sheet paper trays.

- [Load paper to the 2 x 550-sheet paper trays](#)
- [2 x 550-sheet paper tray paper orientation](#)
- [Use alternative letterhead mode](#)

## Load paper to the 2 x 550-sheet paper trays

Use the following process to load paper into the 2 x 550-sheet paper trays.

1. Open the tray.

**NOTE:** Do not open this tray while the printer is printing.

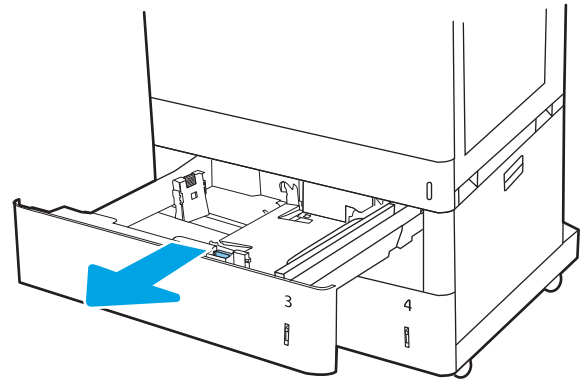

2. Before loading paper, adjust the paper-width guides by squeezing the blue adjustment latches and sliding the guides to the size of the paper being used.

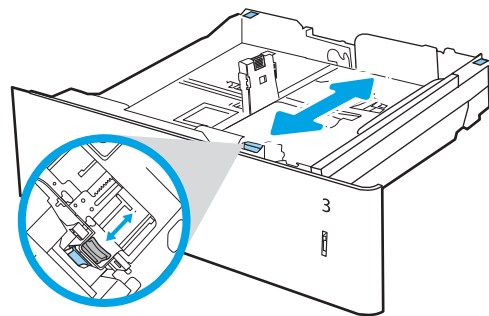

3. Adjust the paper-length guide by squeezing the adjustment latch and sliding the guide to the size of the paper being used.

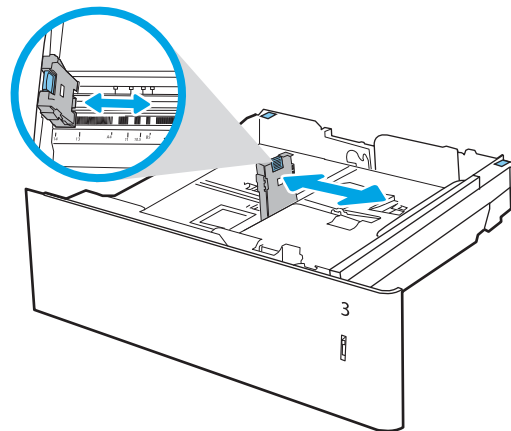

4. For any of the following paper sizes, also adjust the blue paper-stop lever in the left rear corner of the tray to the correct position, as indicated by the label in the tray:

- 12 x 18
- RA3
- 11 x 17
- A3
- SRA3

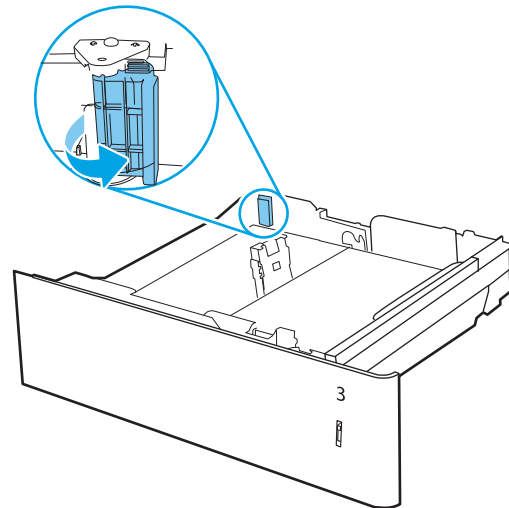

5. Load paper into the tray. For information about how to orient the paper, see [2 x 550-sheet paper tray paper orientation on page 43](#).

**NOTE:** To prevent jams, do not overfill the tray. Be sure that the top of the stack is below the tray full indicator.

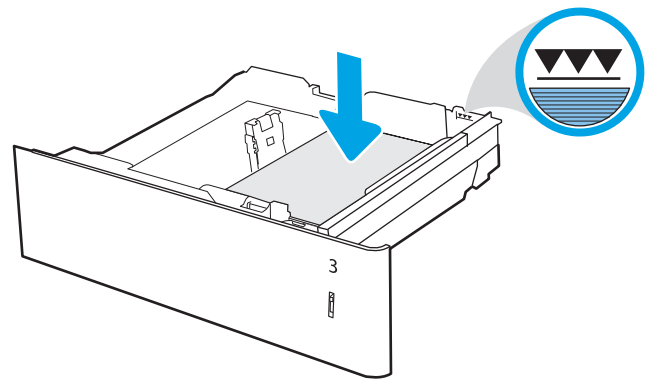

6. Check the paper to verify the guides lightly touch the stack, but do not bend it.

**NOTE:** Do not adjust the paper guides tightly against the paper stack. Adjust them to the indentations or markings in the tray.

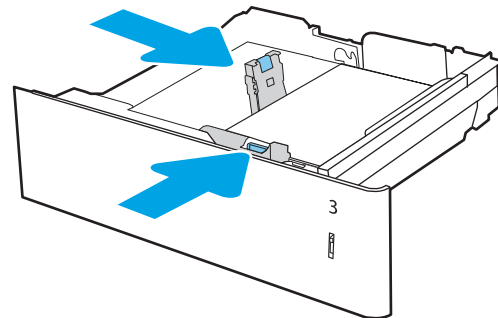

7. Close the tray.

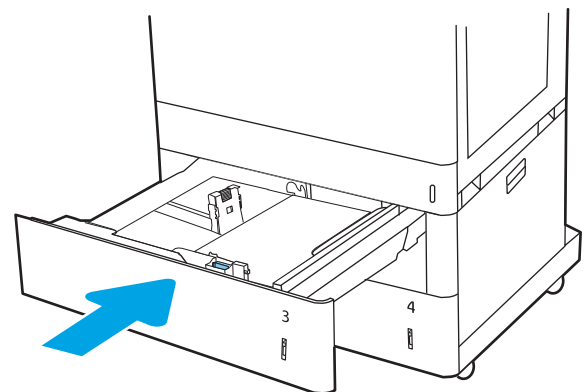

8. The tray configuration message displays on the printer control panel.
9. Press the **OK** button to accept the detected type and size, or select **Modify** to choose a different paper size or type.

For custom-size paper, specify the **X** and **Y** dimensions for the paper when the prompt displays on the printer control panel.

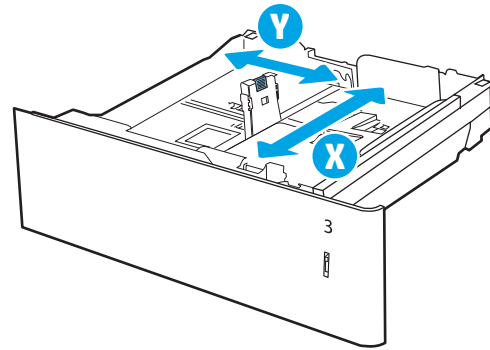

## 2 x 550-sheet paper tray paper orientation

Position paper correctly in the 2 x 550-sheet trays to ensure the best print quality.

**Table 2-11** Letterhead or preprinted—portrait

Duplex mode	Paper size	How to load paper
1-sided printing	A4, Letter, 16K (197x273 mm) 16K (195x270 mm), Executive, A5, 16K (184x260 mm), B5 (JIS), Double Japan Postcard (148x200 mm)	Face-up Top edge at the back of the tray  <b>NOTE:</b> This is the preferred orientation when printing on A4 or Letter.
1-sided printing	12x18, 11x17, A3, 8K (273x397 mm), 8K (270x390 mm), 8K (260x368 mm), B4 (JIS), Legal, Oficio (8.5x13), Oficio (216x340 mm), SRA3, RA3, SRA4, RA4, A4, Letter	Face-up Top edge at the right side of the tray

**Table 2-11 Letterhead or preprinted—portrait (continued)**

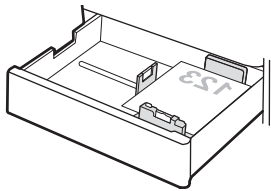
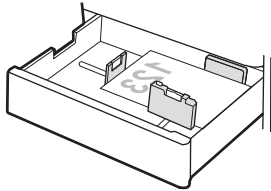
Duplex mode	Paper size	How to load paper
Automatic 2-sided printing or with Alternative Letterhead Mode enabled	A4, Letter, 16K (197x273 mm) 16K (195x270 mm), Executive, A5, 16K (184x260 mm), B5 (JIS), Double Japan Postcard (148x200 mm)	<p>Face-down</p> <p>Top edge at the back of the tray</p> <p><b>NOTE:</b> This is the preferred orientation when printing on A4 or Letter.</p> 
Automatic 2-sided printing or with Alternative Letterhead Mode enabled	12x18, 11x17, A3, 8K (273x397 mm), 8K (270x390 mm), B4 (JIS), Legal, Oficio (8.5x13), Oficio (216x340 mm), SRA3, RA3, SRA4, RA4, A4, Letter	<p>Face-down</p> <p>Top edge at the left side of the tray</p> 

**Table 2-12 Letterhead or preprinted—landscape**

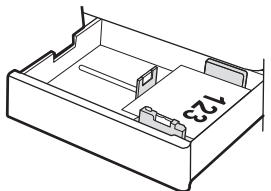
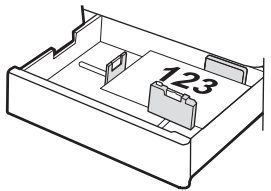
Duplex mode	Paper size	How to load paper
1-sided printing	A4, Letter, 16K (197x273 mm) 16K (195x270 mm), Executive, A5, 16K (184x260 mm), B5 (JIS), Double Japan Postcard (148x200 mm)	<p>Face-up</p> <p>Top edge at the right side of the tray</p> <p><b>NOTE:</b> This is the preferred orientation when printing on A4 or Letter.</p> 
1-sided printing	12x18, 11x17, A3, 8K (273x397 mm), 8K (270x390 mm), B4 (JIS), Legal, Oficio (8.5x13), Oficio (216x340 mm), SRA3, RA3, SRA4, RA4, A4, Letter	<p>Face-up</p> <p>Top edge at the back of the tray</p> 

**Table 2-12 Letterhead or preprinted—landscape (continued)**

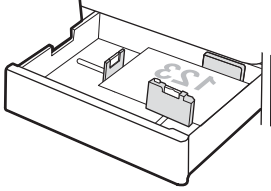
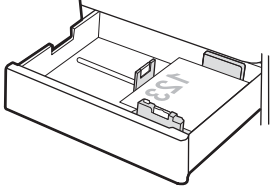
Duplex mode	Paper size	How to load paper
Automatic 2-sided printing or with Alternative Letterhead Mode enabled	12x18, 11x17, A3, 8K (273x397 mm), 8K (270x390 mm), 8K (260x368 mm), B4 (JIS), Legal, Oficio (8.5x13), Oficio (216x340 mm), SRA3, RA3, SRA4, RA4, A4, Letter	<p>Face-down</p> <p>Top edge at the back of the tray</p> 
Automatic 2-sided printing or with Alternative Letterhead Mode enabled	A4, Letter, 16K (197x273 mm) 16K (195x270 mm), Executive, A5, 16K (184x260 mm), B5 (JIS), Double Japan Postcard (148x200 mm)	<p>Face-down</p> <p>Top edge at the left side of the tray</p> <p><b>NOTE:</b> This is the preferred orientation when printing on A4 or Letter.</p> 

**Table 2-13 Prepunched—portrait**

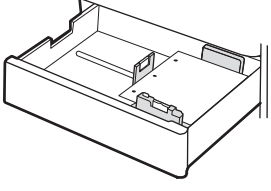
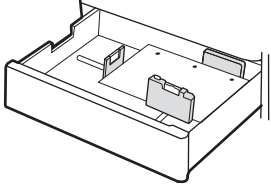
Duplex mode	Paper size	How to load paper
1-sided printing	A4, Letter, 16K (197x273 mm) 16K (195x270 mm), Executive, A5, 16K (184x260 mm), B5 (JIS), Double Japan Postcard (148x200 mm)	<p>Face-up</p> <p>Holes at the left side of the tray, with the top of the form at the rear of the printer</p> <p><b>NOTE:</b> This is the preferred orientation when printing on A4 or Letter.</p> 
1-sided printing	12x18, 11x17, A3, 8K (273x397 mm), 8K (270x390 mm), 8K (260x368 mm), B4 (JIS), Legal, Oficio (8.5x13), Oficio (216x340 mm), SRA3, RA3, SRA4, RA4, A4, Letter	<p>Face-up</p> <p>Holes at the back of the tray</p> 

**Table 2-13** Prepunched—portrait (continued)

Duplex mode	Paper size	How to load paper
Automatic 2-sided printing or with Alternative Letterhead Mode enabled	A4, Letter, 16K (197x273 mm) 16K (195x270 mm), Executive, A5, 16K (184x260 mm), B5 (JIS), Double Japan Postcard (148x200 mm)	<p>Face-down</p> <p>Holes at the right side of the tray</p> <p><b>NOTE:</b> This is the preferred orientation when printing on A4 or Letter.</p>
Automatic 2-sided printing or with Alternative Letterhead Mode enabled	12x18, 11x17, A3, 8K (273x397 mm), 8K (270x390 mm), 8K (260x368 mm), B4 (JIS), Legal, Oficio (8.5x13), Oficio (216x340 mm), SRA3, RA3, SRA4, RA4, A4, Letter	<p>Face-down</p> <p>Holes at the back of the tray</p>

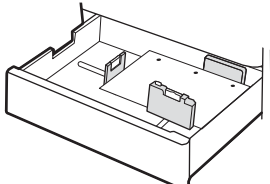
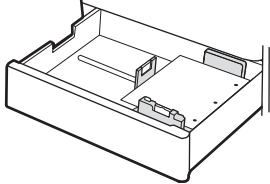



## Use alternative letterhead mode

Use the [Alternative Letterhead Mode](#) feature to load letterhead or preprinted paper into the tray the same way for all jobs, whether printing to one side of the sheet of paper or to both sides. When using this mode, load paper as for automatic duplex printing.

- [Enable Alternative Letterhead Mode by using the printer control-panel menus](#)

### Enable Alternative Letterhead Mode by using the printer control-panel menus

Use the [Settings](#) menu to set the [Alternative Letterhead Mode](#) setting.

1. From the Home screen on the printer control panel, navigate to and open the [Settings](#) menu.
2. Open the following menus:
  - a. [Copy/Print or Print](#)
  - b. [Manage Trays](#)
  - c. [Alternative Letterhead Mode](#)
3. Select [On](#).

# Load paper to the 2,700-sheet high-capacity input paper trays

The following information describes how to load paper into the HCI paper trays.

- [Load paper to the 2,700-sheet high-capacity input paper trays](#)
- [2,700-sheet HCI paper tray paper orientation](#)
- [Use alternative letterhead mode](#)

## Load paper to the 2,700-sheet high-capacity input paper trays

Use the following process to load paper into the HCI paper trays.

1. Release the tray latch, and then slide the tray away from the printer to open it.

**NOTE:** Do not open this tray while the printer is printing.

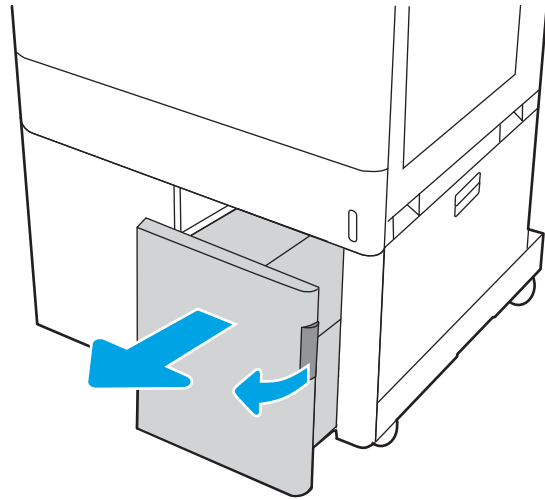

2. Adjust the paper-size guide to the correct position for the paper.

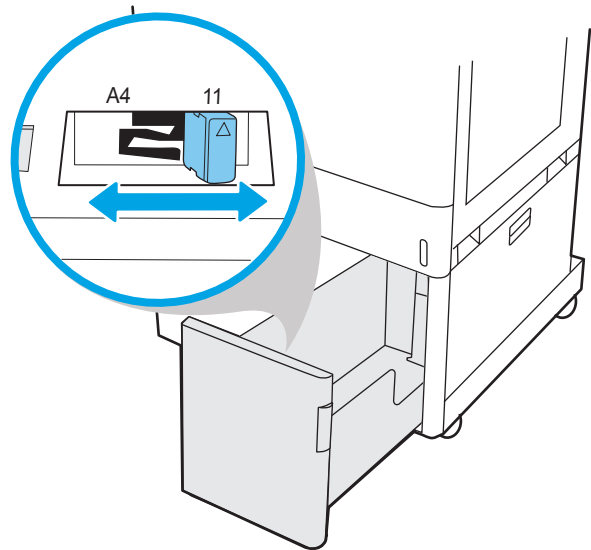

3. Load paper into the tray. Check the paper to verify the guides lightly touch the stack, but do not bend it. For information about how to orient the paper, see [2,700-sheet HCl paper tray paper orientation on page 49](#).

**NOTE:** To prevent jams, do not overfill the tray. Be sure that the top of the stack is below the tray full indicator.

**NOTE:** If the tray is not adjusted correctly, an error message might appear during printing or the paper might jam.

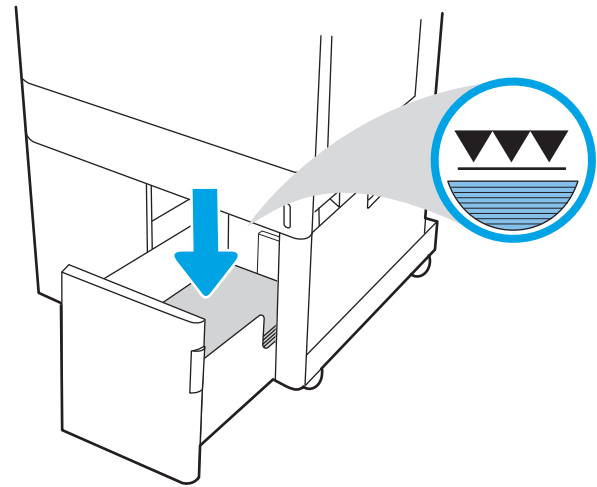

4. Close the tray.

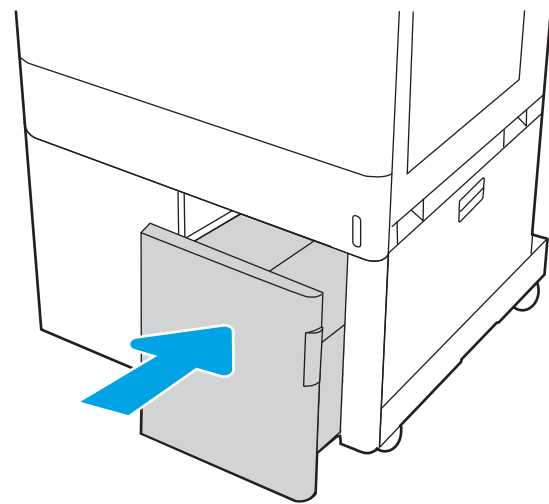

5. The tray configuration message displays on the printer control panel.
6. Press the **OK** button to accept the detected type and size, or select **Modify** to choose a different paper size or type.

## 2,700-sheet HCl paper tray paper orientation

Position paper correctly in the HCl trays to ensure the best print quality.

**Table 2-14** Letterhead or preprinted—portrait

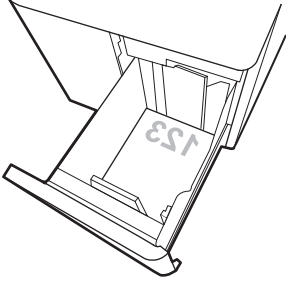
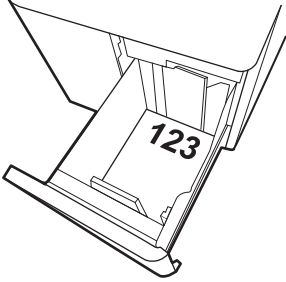
Duplex mode	Paper size	How to load paper
1-sided printing	A4, Letter	Face-down Top edge at the back of the tray 
Automatic 2-sided printing or with Alternative Letterhead Mode enabled	A4, Letter	Face-up Top edge at the back of the tray 

**Table 2-15** Letterhead or preprinted—landscape

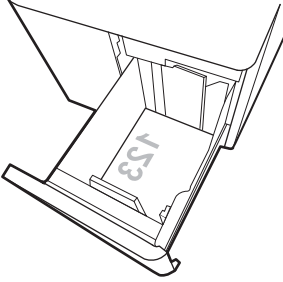
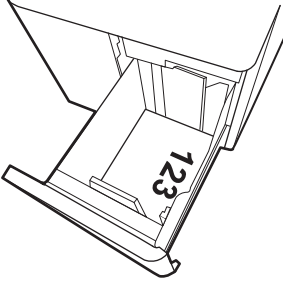
Duplex mode	Paper size	How to load paper
1-sided printing	A4, Letter	Face-down Top edge at the left side of the tray 
Automatic 2-sided printing or with Alternative Letterhead Mode enabled	A4, Letter	Face-up Top edge at the right side of the tray 

**Table 2-16** Prepunched-landscape

Duplex mode	Paper size	How to load paper
1-sided printing	A4, Letter	Face-down Holes at the left side of the tray
Automatic 2-sided printing or with Alternative Letterhead Mode enabled	A4, Letter	Face-up Holes at the right side of the tray, with the top of the form to the right side

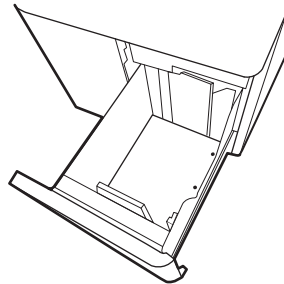
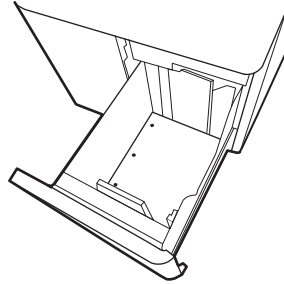

## Use alternative letterhead mode

Use the [Alternative Letterhead Mode](#) feature to load letterhead or preprinted paper into the tray the same way for all jobs, whether printing to one side of the sheet of paper or to both sides. When using this mode, load paper as for automatic duplex printing.

- [Enable Alternative Letterhead Mode by using the printer control-panel menus](#)

### Enable Alternative Letterhead Mode by using the printer control-panel menus

Use the [Settings](#) menu to set the [Alternative Letterhead Mode](#) setting.

1. From the Home screen on the printer control panel, navigate to and open the [Settings](#) menu.
2. Open the following menus:
  - a. [Copy/Print or Print](#)
  - b. [Manage Trays](#)
  - c. [Alternative Letterhead Mode](#)
3. Select [On](#).

## Load and print envelopes

Use only Tray 1 to print on envelopes. Tray 1 holds up to 10 envelopes.

- [Print envelopes](#)
- [Envelope orientation](#)

### Print envelopes

To print envelopes using the manual feed option, follow these steps to select the correct settings in the print driver, and then load the envelopes into the tray after sending the print job to the printer.

1. From the software program, select the **Print** option.
2. Select the printer from the list of printers, and then click the **Properties** or **Preferences** button to open the print driver.

---

 **NOTE:** The name of the button varies for different software programs.

 **NOTE:** To access these features from a Windows 8.1 Start screen app, select **Devices**, select **Print**, and then select the printer.

 **NOTE:** To access these features from Windows 10, select **Print**, and then select the printer.

---

3. Click the **Paper/Quality** tab.
4. In the **Paper size** drop-down list, select the correct size for the envelopes.
5. In the **Paper type** drop-down list, select **Envelope**.
6. In the **Paper source** drop-down list, select **Manual feed**.
7. Click the **OK** button to close the **Document Properties** dialog box.
8. In the **Print** dialog box, click the **OK** button to print the job.

### Envelope orientation

Envelopes need to be loaded in a specific manner in order to print correctly.

---

 **NOTE:** The printer does not support duplex printing on envelopes.

---

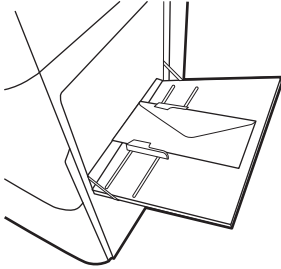
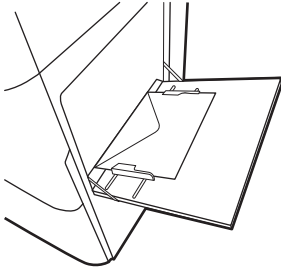

**Table 2-17 Envelope orientation**

Tray	Envelope size	How to load
Tray 1	Envelope #9, Envelope #10, Envelope Monarch, Envelope DL, Envelope B5, Envelope C5 (wallet), Envelope C6	Face-down Top edge toward the back of the printer
	Tray 1	Envelope B5, Envelope C5 (pocket)
	Face-down	Top edge leading into the printer

## Load and print labels

To print on sheets of labels, use Tray 1 or the 550-sheet trays.

- [Manually feed labels](#)
- [Label orientation](#)

### Manually feed labels

Use the manual feed mode to print sheets of labels.

1. From the software program, select the **Print** option.
2. Select the printer from the list of printers, and then click the **Properties** or **Preferences** button to open the print driver.

---

 **NOTE:** The name of the button varies for different software programs.

 **NOTE:** To access these features from a Windows 8.1 Start screen app, select **Devices**, select **Print**, and then select the printer.

 **NOTE:** To access these features from Windows 10, select **Print**, and then select the printer.

---

3. Click the **Paper/Quality** tab.
4. In the **Paper size** drop-down list, select the correct size for the sheets of labels.
5. In the **Paper type** drop-down list, select **Labels**.
6. In the **Paper source** drop-down list, select **Manual feed**.

---

 **NOTE:** When using manual feed, the printer prints from the lowest-numbered tray that is configured for the correct size of paper, so it is not necessary to specify a particular tray. For example, if Tray 2 is configured for labels, the printer will print from Tray 2. If Tray 3 is installed and configured for labels, but Tray 2 is not configured for labels, the printer will print from Tray 3.

---

7. Click the **OK** button to close the **Document Properties** dialog box.
8. In the **Print** dialog box, click the **Print** button to print the job.

### Label orientation

Labels need to be loaded in a specific manner in order to print correctly.

**Table 2-18** Label orientation

Tray	How to load labels
Tray 1	Face-down Bottom edge leading into the printer
550-sheet trays	Face-up Top edge at the back of the tray

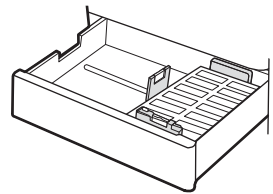
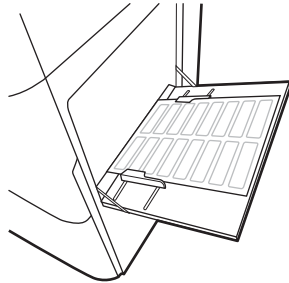



---

## 3 Supplies, accessories, and parts

Order supplies or accessories, replace the toner cartridges, or remove and replace another part.

- [Order supplies, accessories, and parts](#)
- [Replace the toner cartridges](#)
- [Replace the toner-collection unit](#)

For video assistance, see [www.hp.com/videos/LaserJet](http://www.hp.com/videos/LaserJet).

The following information is correct at the time of publication. For current information, see [www.hp.com/support/colorljE85055](http://www.hp.com/support/colorljE85055).

### For more information:

HP's all-inclusive help for the printer includes the following information:

- Install and configure
- Learn and use
- Solve problems
- Download software and firmware updates
- Join support forums
- Find warranty and regulatory information

## Order supplies, accessories, and parts

Find out how to order replacement supplies, accessories, and parts for the printer.

- [Ordering](#)

### Ordering

Contact the managed service representative. Make sure to have the product model number, which appears on the product label on the back of the printer.

# Replace the toner cartridges

Replace the toner cartridge if you receive a message on the printer, or if you have print quality problems.

- [Toner-cartridge information](#)
- [Remove and replace the cartridges](#)

## Toner-cartridge information

This printer indicates when the toner cartridge level is low and very low. The actual toner cartridge life remaining can vary. Consider having a replacement cartridge available to install when print quality is no longer acceptable.

To acquire cartridges, contact the managed service representative. Make sure to have the product model number, which appears on the product label on the back of the printer.

The printer uses four colors and has a different toner cartridge for each color: yellow (Y), magenta (M), cyan (C), and black (K). The toner cartridges are inside the front door.

Do not remove the toner cartridge from its package until it is time to replace it.

**CAUTION:** To prevent damage to the toner cartridge, do not expose it to light for more than a few minutes. Cover the green imaging drum if the toner cartridge must be removed from the printer for an extended period of time.

**CAUTION:** Do not touch the developer roller. Fingerprints on the developer roller can cause print-quality problems.

The following illustration shows the toner-cartridge components.

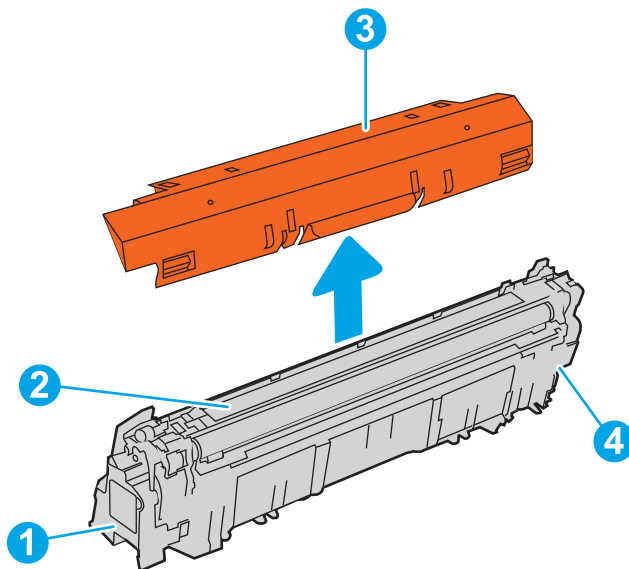

Number	Description
1	Handle
2	Developer roller
3	Protective shield
4	Memory chip

**⚠ CAUTION:** If toner gets on clothing, wipe it off by using a dry cloth and wash the clothes in cold water. Hot water sets toner into fabric.

**📄 NOTE:** Information about recycling used toner cartridges is in the toner-cartridge box.

## Remove and replace the cartridges

Follow these steps to replace a toner cartridge.

1. Open the front door.

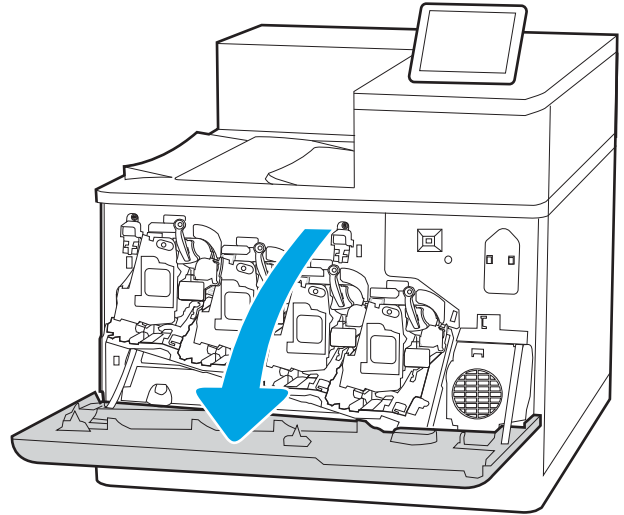

2. Grasp the handle of the used toner cartridge and pull out to remove it.

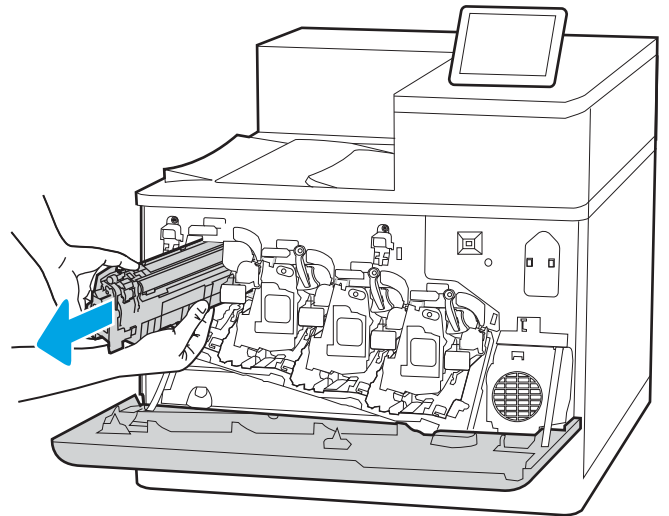



3. Remove the new toner cartridge from its packaging by removing the end caps (callout 1), removing the cartridge from the plastic bag (callout 2), and then removing the orange protective shield (callout 3).

**NOTE:** Do not touch the developer roller. Fingerprints on the developer roller can cause print-quality problems.

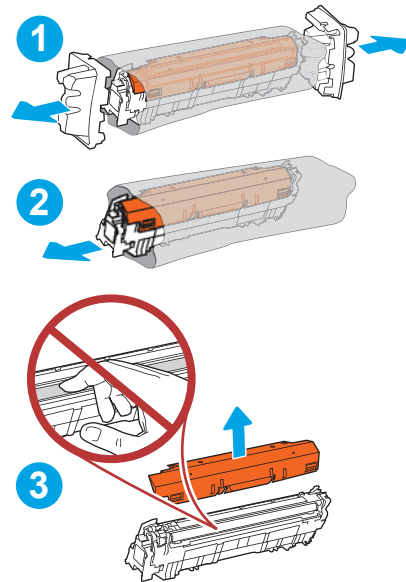

4. Support the toner cartridge underneath with one hand while holding the cartridge handle with the other. Align the toner cartridge with its slot on the shelf, and then insert the toner cartridge into the printer.

**NOTE:** Avoid touching the developer roller. Fingerprints on the developer roller can cause print defects.

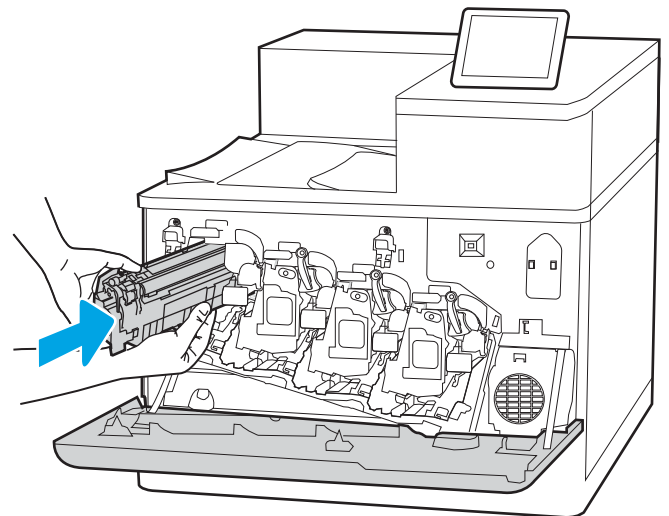

5. Close the front door.

Save all packaging for recycling the used toner cartridge. To recycle the used cartridge, follow the instructions included with the new cartridge.

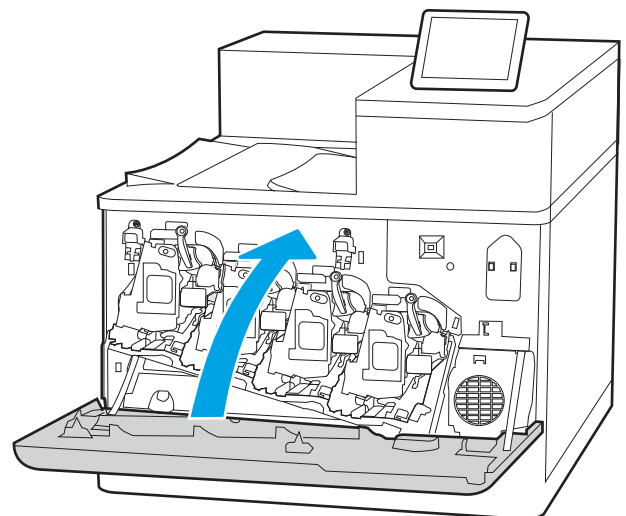

## Replace the toner-collection unit

Replace the toner-collection unit if you receive a message on the printer, or if you have print quality problems.

- [Toner-collection unit information](#)
- [Remove and replace the toner-collection unit](#)

### Toner-collection unit information

This printer indicates when the toner-collection unit (TCU) is almost full. When the TCU is full, the printer will no longer print until the TCU is replaced. Consider having a replacement TCU available to install when the current unit needs to be replaced.

To acquire a TCU, contact the managed service representative. Make sure to have the product model number, which appears on the product label on the back of the printer.

Do not remove the TCU from its package until it is time to replace it.

---

**CAUTION:** If toner gets on clothing, wipe it off by using a dry cloth and wash the clothes in cold water. Hot water sets toner into fabric.

**NOTE:** Information about recycling used TCUs is in the TCU box.

---

### Remove and replace the toner-collection unit

Follow these steps to replace the toner-collection unit.

1. Open the front door.

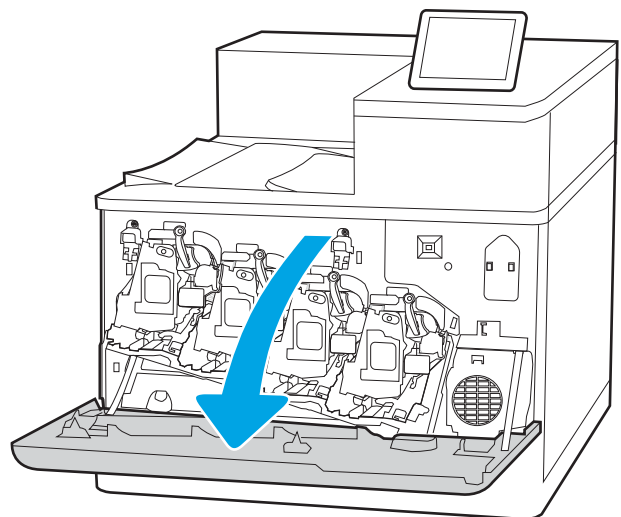

2. Open the left door.

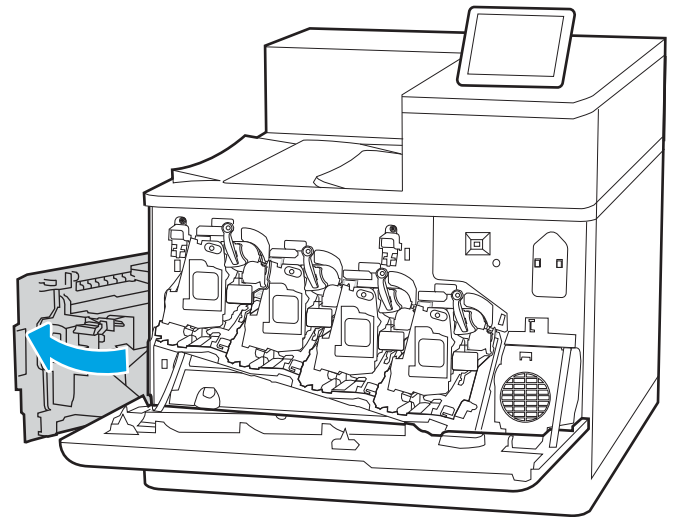

3. Grasp the front of the toner-collection unit and remove it from the printer.

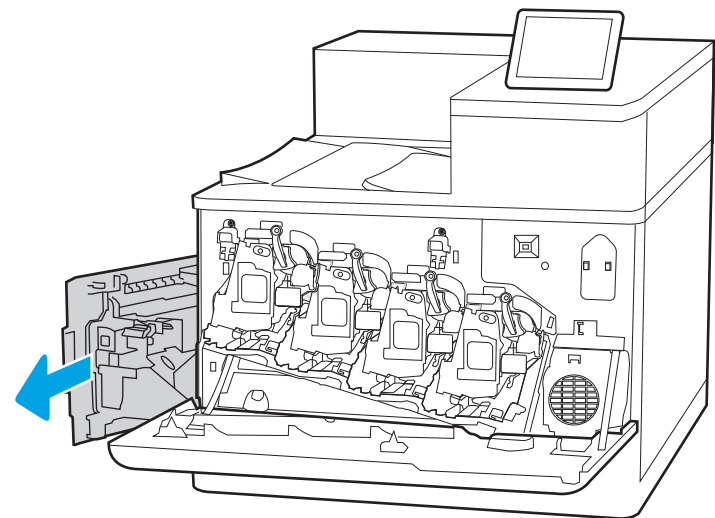

4. Remove the new toner-collection unit from its packaging.

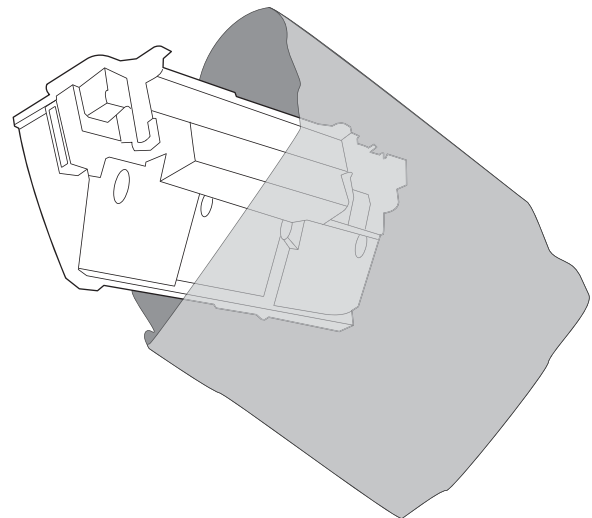

5. Install the new unit into the printer. Make sure the toner-collection unit is firmly in place.

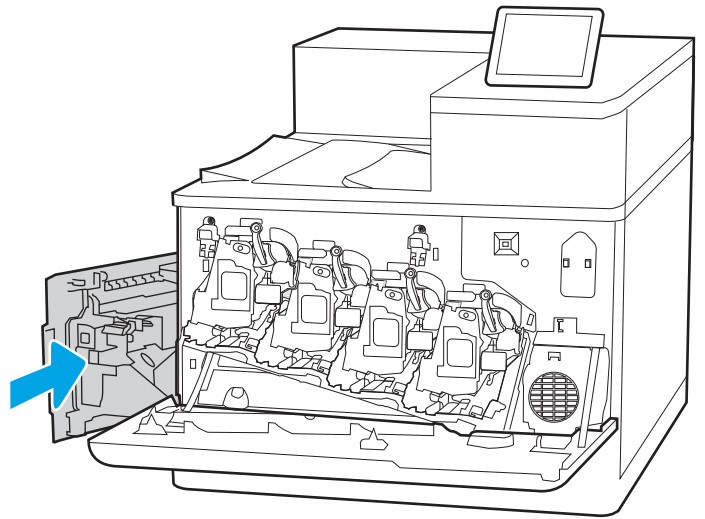

6. Close the left door.

**NOTE:** If the toner-collection unit is not installed correctly, the left door does not close completely.

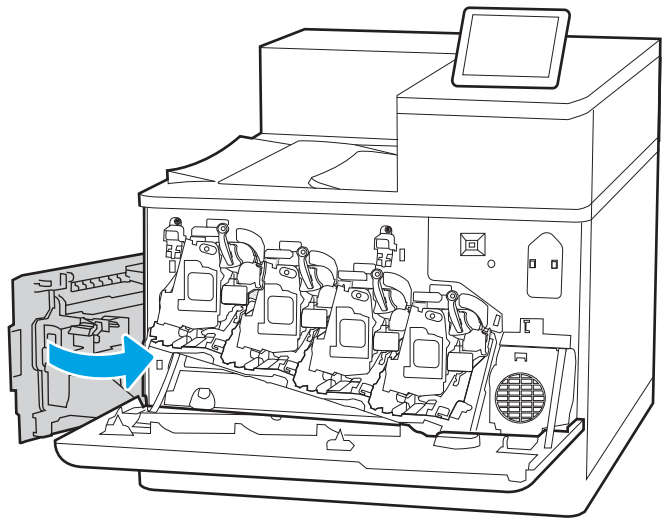

7. Close the front door.

Save all packaging for recycling the used toner-collection unit. To recycle the used toner-collection unit, follow the instructions included with the new toner-collection unit.

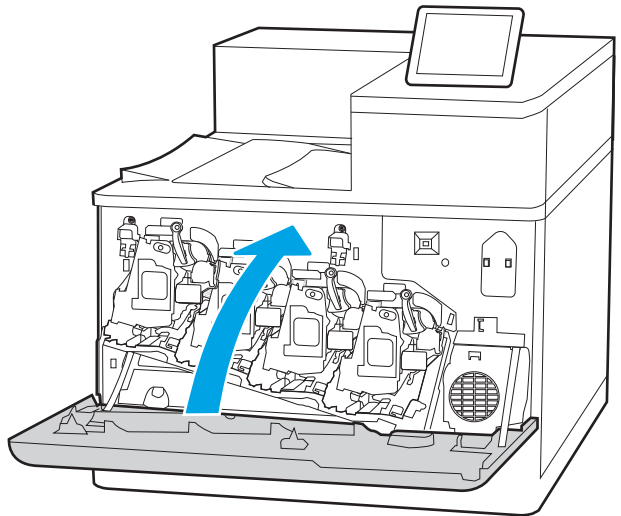

---

# 4 Print

Print using the software, or print from a mobile device or USB flash drive.

- [Print tasks \(Windows\)](#)
- [Print tasks \(macOS\)](#)
- [Store print jobs on the printer to print later or print privately](#)
- [Mobile printing](#)
- [Print from a USB flash drive](#)
- [Print using high-speed USB 2.0 port \(wired\)](#)

For video assistance, see [www.hp.com/videos/LaserJet](http://www.hp.com/videos/LaserJet).

The following information is correct at the time of publication. For current information, see [www.hp.com/support/colorljE85055](http://www.hp.com/support/colorljE85055).

## For more information:

HP's all-inclusive help for the printer includes the following information:

- Install and configure
- Learn and use
- Solve problems
- Download software and firmware updates
- Join support forums
- Find warranty and regulatory information

## Print tasks (Windows)

Learn about common printing tasks for Windows users.

- [How to print \(Windows\)](#)
- [Automatically print on both sides \(Windows\)](#)
- [Manually print on both sides \(Windows\)](#)
- [Print multiple pages per sheet \(Windows\)](#)
- [Select the paper type \(Windows\)](#)
- [Additional print tasks](#)

### How to print (Windows)

Use the **Print** option from a software application to select the printer and basic options for your print job.

The following procedure describes the basic printing process for Windows.

1. From the software program, select the **Print** option.
2. Select the printer from the list of printers. To change settings, click the **Properties** or **Preferences** button to open the print driver.

---

 **NOTE:** The name of the button varies for different software programs.

In Windows 10, 8.1, and 8, these applications will have a different layout with different features from what is described below for desktop applications. To access the print feature from a Start screen app, complete the following steps:

- **Windows 10:** Select **Print**, and then select the printer.
- **Windows 8.1 or 8:** Select **Devices**, select **Print**, and then select the printer.

For the HP PCL-6 V4 driver, the HP AiO Printer Remote application downloads additional driver features when **More settings** is selected.

---

 **NOTE:** For more information, click the Help (?) button in the print driver.

3. Click the tabs in the print driver to configure the available options. For example, set the paper orientation on the **Finishing** tab, and set the paper source, paper type, paper size, and quality settings on the **Paper/Quality** tab.
4. Click the **OK** button to return to the **Print** dialog box. Select the number of copies to print from this screen.
5. Click the **Print** button to print the job.

### Automatically print on both sides (Windows)

If your printer has an automatic duplexer installed, you can automatically print on both sides of the paper. Use a paper size and type supported by the duplexer.

1. From the software program, select the **Print** option.
2. Select the printer from the list of printers, and then click the **Properties** or **Preferences** button to open the print driver.

---

 **NOTE:** The name of the button varies for different software programs.

In Windows 10, 8.1, and 8, these applications will have a different layout with different features from what is described below for desktop applications. To access the print feature from a Start screen app, complete the following steps:

- **Windows 10:** Select **Print**, and then select the printer.
- **Windows 8.1 or 8:** Select **Devices**, select **Print**, and then select the printer.

For the HP PCL-6 V4 driver, the HP AiO Printer Remote application downloads additional driver features when **More settings** is selected.

---

3. Click the **Finishing** tab.
4. Select **Print on both sides**. Click **OK** to close the **Document Properties** dialog.
5. In the **Print** dialog, click **Print** to print the job.

## Manually print on both sides (Windows)

Use this procedure for printers that do not have an automatic duplexer installed or to print on paper that the duplexer does not support.

1. From the software program, select the **Print** option.
2. Select the printer from the list of printers, and then click the **Properties** or **Preferences** button to open the print driver.

---

 **NOTE:** The name of the button varies for different software programs.

In Windows 10, 8.1, and 8, these applications will have a different layout with different features from what is described below for desktop applications. To access the print feature from a Start screen app, complete the following steps:

- **Windows 10:** Select **Print**, and then select the printer.
- **Windows 8.1 or 8:** Select **Devices**, select **Print**, and then select the printer.

For the HP PCL-6 V4 driver, the HP AiO Printer Remote application downloads additional driver features when **More settings** is selected.

---

3. Click the **Finishing** tab.
4. Select **Print on both sides (manually)**, and then click **OK** to close the **Document Properties** dialog.
5. In the **Print** dialog, click **Print** to print the first side of the job.
6. Retrieve the printed stack from the output bin, and place it in Tray 1.
7. If prompted, select the appropriate control panel button to continue.

## Print multiple pages per sheet (Windows)

When you print from a software application using the **Print** option, you can select an option to print multiple pages on a single sheet of paper. For example, you might want to do this if you are printing a very large document and want to save paper.

1. From the software program, select the **Print** option.
2. Select the printer from the list of printers, and then click the **Properties** or **Preferences** button to open the print driver.

---

 **NOTE:** The name of the button varies for different software programs.

In Windows 10, 8.1, and 8, these applications will have a different layout with different features from what is described below for desktop applications. To access the print feature from a Start screen app, complete the following steps:

- **Windows 10:** Select **Print**, and then select the printer.
- **Windows 8.1 or 8:** Select **Devices**, select **Print**, and then select the printer.

For the HP PCL-6 V4 driver, the HP AiO Printer Remote application downloads additional driver features when **More settings** is selected.

---

3. Click the **Finishing** tab.
4. Select the number of pages per sheet from the **Pages per sheet** drop-down.
5. Select the correct **Print page borders**, **Page order**, and **Orientation** options. Click **OK** to close the **Document Properties** dialog.
6. In the **Print** dialog, click **Print** to print the job.

## Select the paper type (Windows)

When you print from a software application using the **Print** option, you can set the paper type you are using for your print job. For example, if your default paper type is Letter, but you are using a different paper type for a print job, select that specific paper type.

1. From the software program, select the **Print** option.
2. Select the printer from the list of printers, and then click the **Properties** or **Preferences** button to open the print driver.

---

 **NOTE:** The name of the button varies for different software programs.

In Windows 10, 8.1, and 8, these applications will have a different layout with different features from what is described below for desktop applications. To access the print feature from a Start screen app, complete the following steps:

- **Windows 10:** Select **Print**, and then select the printer.
- **Windows 8.1 or 8:** Select **Devices**, select **Print**, and then select the printer.

For the HP PCL-6 V4 driver, the HP AiO Printer Remote application downloads additional driver features when **More settings** is selected.

---

3. Click the **Paper/Quality** tab.
4. Select the paper type from the **Paper type** drop-down list.
5. Click **OK** to close the **Document Properties** dialog. In the **Print** dialog, click **Print** to print the job.

If the tray needs to be configured, a tray configuration message displays on the printer control panel.



6. Load the tray with the specified type and size of paper, and then close the tray.
7. Touch the **OK** button to accept the detected type and size, or touch the **Modify** button to choose a different paper size or type.
8. Select the correct type and size, and then touch the **OK** button.

## Additional print tasks

Locate information on the Web for performing common printing tasks.

Go to [www.hp.com/support/colorljE85055](http://www.hp.com/support/colorljE85055).

Instructions are available for print tasks, such as the following:

- Create and use printing shortcuts or presets
- Select the paper size, or use a custom paper size
- Select the page orientation
- Create a booklet
- Scale a document to fit a specific paper size
- Print the first or last pages of the document on different paper
- Print watermarks on a document

## Print tasks (macOS)

Print using the HP printing software for macOS, including how to print on both sides or print multiple pages per sheet.

- [How to print \(macOS\)](#)
- [Automatically print on both sides \(macOS\)](#)
- [Manually print on both sides \(macOS\)](#)
- [Print multiple pages per sheet \(macOS\)](#)
- [Select the paper type \(macOS\)](#)
- [Additional print tasks](#)

### How to print (macOS)

Use the **Print** option from a software application to select the printer and basic options for your print job.

The following procedure describes the basic printing process for macOS.

1. Click the **File** menu, and then click the **Print** option.
2. Select the printer.
3. Click **Show Details** or **Copies & Pages**, and then select other menus to adjust the print settings.

---

 **NOTE:** The name of the item varies for different software programs.

---

4. Click the **Print** button.

### Automatically print on both sides (macOS)

If your printer has an automatic duplexer installed, you can automatically print on both sides of the paper. Use a paper size and type supported by the duplexer.

---

 **NOTE:** This information applies to printers that include an automatic duplexer.

---

 **NOTE:** This feature is available if you install the HP print driver. It might not be available if you are using AirPrint®.

---

1. Click the **File** menu, and then click the **Print** option.
2. Select the printer.
3. Click **Show Details** or **Copies & Pages**, and then click the **Layout** menu.

**macOS 10.14 Mojave and later:** Click **Show Details**, click **Two-Sided**, and then click the **Layout** menu.

---

 **NOTE:** The name of the item varies for different software programs.

---

4. Select a binding option from the **Two-Sided** drop-down list.
5. Click the **Print** button.

## Manually print on both sides (macOS)

Use this procedure for printers that do not have an automatic duplexer installed or to print on paper that the duplexer does not support.

---

 **NOTE:** This feature is available if you install the HP print driver. It might not be available if you are using AirPrint.

---

1. Click the **File** menu, and then click the **Print** option.
2. Select the printer.
3. Click **Show Details** or **Copies & Pages**, and then click the **Manual Duplex** menu.

---

 **NOTE:** The name of the item varies for different software programs.

---

4. Click the **Manual Duplex** box, and select a binding option.
5. Click the **Print** button.
6. Go to the printer and remove any blank paper that is in Tray 1.
7. Retrieve the printed stack from the output bin and place it with the printed-side facing down in the input tray.
8. If prompted, touch the appropriate control panel button to continue.

## Print multiple pages per sheet (macOS)

When you print from a software application using the **Print** option, you can select an option to print multiple pages on a single sheet of paper. For example, you might want to do this if you are printing a very large document and want to save paper.

1. Click the **File** menu, and then click the **Print** option.
2. Select the printer.
3. Click **Show Details** or **Copies & Pages**, and then click the **Layout** menu.

---

 **NOTE:** The name of the item varies for different software programs.

---

4. From the **Pages per Sheet** drop-down list, select the number of pages that you want to print on each sheet.
5. In the **Layout Direction** area, select the order and placement of the pages on the sheet.
6. From the **Borders** menu, select the type of border to print around each page on the sheet.
7. Click the **Print** button.

## Select the paper type (macOS)

When you print from a software application using the **Print** option, you can set the paper type you are using for your print job. For example, if your default paper type is Letter, but you are using a different paper type for a print job, select that specific paper type.

1. Click the **File** menu, and then click the **Print** option.
2. Select the printer.
3. Click **Show Details** or **Copies & Pages**, and then click the **Media & Quality** menu or the **Paper/Quality** menu.

---

 **NOTE:** The name of the item varies for different software programs.

---

4. Select from the **Media & Quality** or **Paper/Quality** options.

---

 **NOTE:** This list contains the master set of options available. Some options are not available on all printers.

---

- **Media Type:** Select the option for the type of paper for the print job.
  - **Print Quality or Quality:** Select the resolution level for the print job.
  - **Edge-To-Edge Printing:** Select this option to print close to the paper edges.
5. Click the **Print** button.

## Additional print tasks

Locate information on the Web for performing common printing tasks.

Go to [www.hp.com/support/colorljE85055](http://www.hp.com/support/colorljE85055).

Instructions are available for print tasks, such as the following:

- Create and use printing shortcuts or presets
- Select the paper size, or use a custom paper size
- Select the page orientation
- Create a booklet
- Scale a document to fit a specific paper size
- Print the first or last pages of the document on different paper
- Print watermarks on a document

# Store print jobs on the printer to print later or print privately

Store print jobs in the printer memory for printing at a later time.

- [Introduction](#)
- [Create a stored job \(Windows\)](#)
- [Create a stored job \(macOS\)](#)
- [Print a stored job](#)
- [Delete a stored job](#)
- [Information sent to printer for Job Accounting purposes](#)

## Introduction

The following information provides procedures for creating and printing documents that are stored on the USB flash drive. These jobs can be printed at a later time or printed privately.

## Create a stored job (Windows)

Store jobs on the USB flash drive for private or delayed printing.

1. From the software program, select the **Print** option.
2. Select the printer from the list of printers, and then select **Properties** or **Preferences**.



**NOTE:** The name of the button varies for different software programs.

In Windows 10, 8.1, and 8, these applications will have a different layout with different features from what is described below for desktop applications. To access the print feature from a Start screen app, complete the following steps:

- **Windows 10:** Select **Print**, and then select the printer.
- **Windows 8.1 or 8:** Select **Devices**, select **Print**, and then select the printer.

For the HP PCL-6 V4 driver, the HP AiO Printer Remote application downloads additional driver features when **More settings** is selected.

3. Click the **Job Storage** tab.
4. Select a **Job Storage Mode** option:
  - **Proof and Hold:** Print and proof one copy of a job, and then print more copies.
  - **Personal Job:** The job does not print until you request it at the printer control panel. For this job-storage mode, you can select one of the **Make Job Private/Secure** options. If you assign a personal identification number (PIN) to the job, you must provide the required PIN at the control panel. If you encrypt the job, you must provide the required password at the control panel. The print job is deleted from memory after it prints and is lost if the printer loses power.

- **Quick Copy:** Print the requested number of copies of a job and store a copy of the job in the printer memory so you can print it again later.
  - **Stored Job:** Store a job on the printer and allow other users to print the job at any time. For this job-storage mode, you can select one of the **Make Job Private/Secure** options. If you assign a personal identification number (PIN) to the job, the person who prints the job must provide the required PIN at the control panel. If you encrypt the job, the person who prints the job must provide the required password at the control panel.
5. To use a custom user name or job name, click the **Custom** button, and then enter the user name or the job name.
- Select which option to use if another stored job already has that name:
- **Use Job Name + (1-99):** Append a unique number to the end of the job name.
  - **Replace Existing File:** Overwrite the existing stored job with the new one.
6. Click the **OK** button to close the **Document Properties** dialog box. In the **Print** dialog box, click the **Print** button to print the job.

## Create a stored job (macOS)

Store jobs on the USB flash drive for private or delayed printing.

1. Click the **File** menu, and then click the **Print** option.
2. In the **Printer** menu, select the printer.
3. Click **Show Details** or **Copies & Pages**, and then click the **Job Storage** menu.



**NOTE:** If the **Job Storage** menu is not showing, follow the instructions in the "Disable or enable job storage feature" section to activate the menu.

---

4. In the **Mode** drop-down list, select the type of stored job.
  - **Proof and Hold:** Print and proof one copy of a job, and then print more copies. The first copy prints immediately. Printing of the subsequent copies must be initiated from the device's front control panel. For example, if 10 copies are sent, one copy prints immediately, and the other nine copies will print when the job is retrieved. The job is deleted after all copies are printed.
  - **Personal Job:** The job does not print until someone requests it at the printer control panel. If the job has a personal identification number (PIN), provide the required PIN at the control panel. The print job is deleted from memory after it prints.
  - **Quick Copy:** Print the requested number of copies of a job and store a copy of the job in the printer memory to print it again later. The job is deleted manually or by the job retention schedule.
  - **Stored Job:** Store a job on the printer and allow other users to print the job at any time. If the job has a personal identification number (PIN), the person who prints the job must provide the required PIN at the control panel. The job is deleted manually or by the job retention schedule.
5. To use a custom user name or job name, click the **Custom** button, and then enter the user name or the job name.



**NOTE:** **macOS 10.14 Mojave and later:** The print driver no longer includes the **Custom** button. Use the options below the **Mode** drop-down list to set up the saved job.

---

Select which option to use if another stored job already has that name.

- **Use Job Name + (1-99):** Append a unique number to the end of the job name.
  - **Replace Existing File:** Overwrite the existing stored job with the new one.
6. If you selected the **Stored Job** or **Personal Job** option in the **Mode** drop-down list, you can protect the job with a PIN. Type a 4-digit number in the **Use PIN to Print** field. When other people attempt to print this job, the printer prompts them to enter this PIN.
  7. Click the **Print** button to process the job.

## Print a stored job

Use the following procedure to print a job that is stored in the printer memory.

1. From the Home screen on the printer control panel, select [Print from Job Storage](#).
2. Select [Choose](#), and then select the name of the folder where the job is stored.
3. Select the name of the job. If the job is private or encrypted, enter the PIN or password.
4. To adjust the number of copies, select the number of copies field. Use the keypad to enter the number of copies to print.
5. Select Start  or [Print](#) to print the job.

## Delete a stored job

You can delete documents that have been saved to the printer when they are no longer needed. You can also adjust the maximum number of jobs for the printer to store.

- [Delete a job that is stored on the printer](#)
- [Change the job storage limit](#)

### Delete a job that is stored on the printer

Use the control panel to delete a job that is stored in the printer memory.

1. From the Home screen on the printer control panel, select the [Print from Job Storage](#) icon.
2. Select [Choose](#), and then select the name of the folder where the job is stored.
3. Select the name of the job. If the job is private or encrypted, enter the PIN or password.
4. Select the Trash button  to delete the job.

### Change the job storage limit

When a new job is stored in the printer memory, the printer overwrites any previous jobs with the same user and job name. If a job is not already stored under the same user and job name, and the printer needs additional space, the printer might delete other stored jobs starting with the oldest.

To change the number of jobs that the printer can store, complete the following procedure:

1. From the Home screen on the printer control panel, navigate to the [Settings](#) application, and then select the [Settings](#) icon.
2. Open the following menus:
  - a. [Copy/Print](#) or [Print](#)
  - b. [Manage Stored Jobs](#)
  - c. [Temporary Job Storage Limit](#)
3. Use the keypad to enter the number of jobs that the printer stores.
4. Select [OK](#) or [Done](#) to save the setting.

## Information sent to printer for Job Accounting purposes

Printing jobs sent from drivers on the client (e.g., PC) may send personally identifiable information to HP's Printing and Imaging devices. This information may include, but is not limited to, user name and client name from which the job originated that may be used for job accounting purposes, as determined by the Administrator of the printing device. This same information may also be stored with the job on the mass storage device (e.g., disk drive) of the printing device when using the job storage feature.



# Mobile printing

Mobile and ePrint solutions enable easy printing to an HP printer from a laptop, tablet, smartphone, or other mobile device.

- [Introduction](#)
- [Wi-Fi, Wi-Fi Direct Print, NFC, and BLE printing](#)
- [HP ePrint via email](#)
- [AirPrint](#)
- [Android embedded printing](#)

## Introduction

HP offers multiple mobile printing solutions to enable easy printing to an HP printer from a laptop, tablet, smartphone, or other mobile device.

To see the full list and to determine the best choice, go to [www.hp.com/go/LaserJetMobilePrinting](http://www.hp.com/go/LaserJetMobilePrinting).

## Wi-Fi, Wi-Fi Direct Print, NFC, and BLE printing

HP provides Wi-Fi Direct Print, Near Field Communication (NFC), and Bluetooth Low Energy (BLE) printing for printers with a supported HP Jetdirect 3100w BLE/NFC/Wireless Accessory. This accessory is available as an option for HP printers that include a hardware-integration pocket (HIP).

- [Enable wireless printing](#)
- [Change the Wi-Fi Direct name](#)

These features enable Wi-Fi capable (mobile) devices to make a wireless network connection directly to the printer without using a wireless router.

The printer does not need to be connected to the network for this mobile walk-up printing to work.

Use Wi-Fi Direct Print to print wirelessly from the following devices:

- iPhone, iPad, or iPod touch using Apple AirPrint
- Android mobile devices using the Android embedded print solution

For more information on wireless printing, go to [www.hp.com/go/LaserJetMobilePrinting](http://www.hp.com/go/LaserJetMobilePrinting).

NFC, BLE, and Wi-Fi Direct Print capabilities can be enabled or disabled from the printer control panel.

### Enable wireless printing



To print wirelessly from mobile devices, Wi-Fi Direct must be turned on.

1. From the Home screen on the printer control panel, select the [Settings](#) menu.
2. Select the following menus:
  - a. [Networking](#)
  - b. [Wi-Fi Direct](#)
  - c. [Status](#)
3. Select [On](#), and then select [OK](#) to enable wireless printing.

### Change the Wi-Fi Direct name

Change the printer Wi-Fi Direct name using the HP Embedded Web Server (EWS).

---

 **NOTE:** In environments where more than one model of the same printer is installed, it might be helpful to provide each printer a unique Wi-Fi Direct Name for easier printer identification for HP Wi-Fi Direct printing. The Wireless network names, e.g., Wireless, Wi-Fi Direct, etc. are available on the Information screen by selecting the Information icon , and then selecting the Wi-Fi Direct icon .

---

Complete the following procedure to change the printer Wi-Fi Direct name:

1. From the Home screen on the printer control panel, select the [Settings](#) icon.
2. Open the following menus:

- a. [Networking](#)
  - b. [Wi-Fi Direct](#)
  - c. [Wi-Fi Direct Name](#)
3. Use the keypad to change the name in the [Wi-Fi Direct Name](#) text field, and then select **OK**.



## HP ePrint via email

Use HP ePrint via email to print documents by sending them as an email attachment to the printer's email address from any email enabled device.

To use HP ePrint via email, the printer must meet these requirements:

- The printer must be connected to a wired or wireless network and have Internet access.
- HP Web Services must be enabled on the printer, and the printer must be registered with HP Connected.

Follow this procedure to enable HP Web Services and register with HP Connected:

1. Open the HP Embedded Web Server (EWS):
  - a. From the Home screen on the printer control panel, touch the Information icon , and then touch the Ethernet icon  to display the IP address or host name.
  - b. From a computer on the same network as the printer, open a web browser. In the address line, type the IP address or host name exactly as it displays on the printer control panel. Press the **Enter** key on the computer keyboard. The EWS opens.

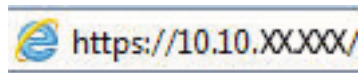

 **NOTE:** If the web browser displays a message indicating that accessing the website might not be safe, select the option to continue to the website. Accessing this website will not harm the computer.

2. Click the **HP Web Services** tab.
3. Select the option to enable Web Services.

 **NOTE:** Enabling Web Services might take several minutes.
4. Go to [www.hpconnected.com](http://www.hpconnected.com) to create an HP ePrint account and complete the setup process.

## AirPrint

Direct printing using Apple's AirPrint is supported for iOS and from Mac computers running macOS 10.7 Lion and newer.

Use AirPrint to print directly to the printer from an iPad, iPhone (3GS or later), or iPod touch (third generation or later) in the following mobile applications:

- Mail
- Photos
- Safari

- iBooks
- Select third-party applications

To use AirPrint, the printer must be connected to the same network (sub-net) as the Apple device. For more information about using AirPrint and about which HP printers are compatible with AirPrint, go to [www.hp.com/go/MobilePrinting](http://www.hp.com/go/MobilePrinting).



**NOTE:** Before using AirPrint with a USB connection, verify the version number. AirPrint versions 1.3 and earlier do not support USB connections.

---

## Android embedded printing

HP's built-in print solution for Android and Kindle enables mobile devices to automatically find and print to HP printers that are either on a network or within wireless range for Wi-Fi Direct printing.

The print solution is built into many versions of the operating system.



**NOTE:** If printing is not available on your device, go to the [Google Play > Android apps](#) and install the HP Print Service Plugin.

---

For more information on how to use Android embedded printing and which Android devices are supported, go to [www.hp.com/go/MobilePrinting](http://www.hp.com/go/MobilePrinting).

## Print from a USB flash drive

This printer features easy-access USB printing to print files without a computer.

- [Enable the USB port for printing](#)
- [Print USB documents](#)

The printer accepts standard USB flash drives in the USB port near the control panel. It supports the following types of files:

- .pdf
- .prn
- .pcl
- .ps
- .cht

## Enable the USB port for printing

The USB port is disabled by default. Before using this feature, enable the USB port.

- [Method one: Enable the USB port from the printer control panel](#)
- [Method two: Enable the USB port from the HP Embedded Web Server \(network-connected printers only\)](#)

Use one of the following methods to enable the port:



### Method one: Enable the USB port from the printer control panel

Use the printer control panel to enable the USB port for printing.

1. From the Home screen on the printer control panel, navigate to the **Settings** application, and then select the **Settings** icon.
2. Open the following menus:
  - a. **Copy/Print** or **Print**
  - b. **Enable Device USB**
3. Select **Enable Print from USB Drive**.

### Method two: Enable the USB port from the HP Embedded Web Server (network-connected printers only)

Use the HP Embedded Web Server to enable the USB port for printing.

1. From the Home screen on the printer control panel, touch the Information icon , and then touch the Ethernet icon  to display the IP address or host name.
2. Open a web browser, and in the address line, type the IP address exactly as it displays on the printer control panel. Press the **ENTER** key on the computer keyboard. The EWS opens.

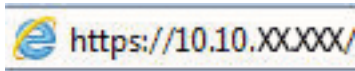

 **NOTE:** If the web browser displays a message indicating that accessing the website might not be safe, select the option to continue to the website. Accessing this website will not harm the computer.

3. Select the **Copy/Print** tab for MFP models or the **Print** tab for SFP models.
4. In the left menu, select **Print from USB Drive Settings**.
5. Select **Enable Print from USB Drive**.
6. Click **Apply**.

## Print USB documents

Print documents from a USB flash drive.

1. Insert the USB flash drive into the easy-access USB port.

---

 **NOTE:** The port might be covered. For some printers, the cover flips open. For other printers, pull the cover straight out to remove it.

---

2. From the Home screen on the printer control panel, navigate to the **Print** application, and then select the **Print** icon.
3. Select **Print from USB Drive**.
4. Select **Choose**, select the name of the document to print, and then select **Select**.

---

 **NOTE:** The document might be in a folder. Open folders as necessary.

---

5. To adjust the number of copies, touch the box to the left of the **Print** button, and then select the number of copies from the keypad that opens. To close the keypad, select the Close button .
6. Select **Print** to print the document.

## Print using high-speed USB 2.0 port (wired)

Enable the high-speed USB 2.0 port for wired USB printing. The port is located in the interface ports area and is disabled by default.

- [Method one: Enable the high-speed USB 2.0 port from the printer control panel menus](#)
- [Method two: Enable the high-speed USB 2.0 port from the HP Embedded Web Server \(network-connected printers only\)](#)

Use one of the following methods to enable the high-speed USB 2.0 port. Once the port is enabled, install the product software in order to print using this port.



### Method one: Enable the high-speed USB 2.0 port from the printer control panel menus

Use the control panel to enable the port.

1. From the Home screen on the printer control panel, navigate to the [Settings](#) application, and then select the [Settings](#) icon.
2. Open the following menus:
  - a. [General](#)
  - b. [Enable Device USB](#)
3. Select the [Enabled](#) option.

### Method two: Enable the high-speed USB 2.0 port from the HP Embedded Web Server (network-connected printers only)

Use the HP EWS to enable the port.

1. Find the printer IP address. On the printer control panel, select the Information button , and then select the Network icon  to display the IP address or host name.
2. Open a web browser, and in the address line, type the IP address exactly as it displays on the printer control panel. Press the **ENTER** key on the computer keyboard. The EWS opens.

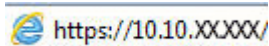

 **NOTE:** If the web browser displays a message indicating that accessing the website might not be safe, select the option to continue to the website. Accessing this website will not harm the computer.

3. Select the **Security** tab.
4. On the left side of the screen, select **General Security**.
5. Scroll down to the **Hardware Ports** and select the following check boxes:
  - a. **Enable Device USB**
  - b. **Enable Host USB plug and play**
6. Click **Apply**.



---

# 5 Manage the printer

Utilize management tools, configure security and energy-conservation settings, and manage firmware updates for the printer.

- [Advanced configuration with the HP Embedded Web Server \(EWS\)](#)
- [Configure IP network settings](#)
- [Printer security features](#)
- [Energy-conservation settings](#)
- [HP Web Jetadmin](#)

For video assistance, see [www.hp.com/videos/LaserJet](http://www.hp.com/videos/LaserJet).

The following information is correct at the time of publication. For current information, see [www.hp.com/support/colorljE85055](http://www.hp.com/support/colorljE85055).

## For more information:

HP's all-inclusive help for the printer includes the following information:

- Install and configure
- Learn and use
- Solve problems
- Download software and firmware updates
- Join support forums
- Find warranty and regulatory information

# Advanced configuration with the HP Embedded Web Server (EWS)

Use the HP Embedded Web Server to manage advanced printing functions.

- [Introduction](#)
- [How to access the HP Embedded Web Server \(EWS\)](#)
- [HP Embedded Web Server features](#)

## Introduction

Use the HP Embedded Web Server to manage printing functions from a computer instead of the printer control panel.

- View printer status information
- Determine the remaining life for all supplies and order new ones
- View and change tray configurations
- View and change the printer control-panel menu configuration
- View and print internal pages
- Receive notification of printer and supplies events
- View and change network configuration

The HP Embedded Web Server works when the printer is connected to an IP-based network. The HP Embedded Web Server does not support IPX-based printer connections. Internet access is not needed to open and use the HP Embedded Web Server.

When the printer is connected to the network, the HP Embedded Web Server is automatically available.



---

 **NOTE:** The HP Embedded Web Server is not accessible beyond the network firewall.

---

## How to access the HP Embedded Web Server (EWS)

Use the following steps to open the EWS.

1. On the printer control panel, press the Information button , and then use the arrow keys to select the Ethernet menu . Press the **OK** button to open the menu and display the IP address or host name.
2. Open a web browser, and in the address line, type the IP address or host name exactly as it displays on the printer control panel. Press the **Enter** key on the computer keyboard. The EWS opens.

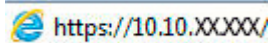
 <https://10.10.XXXXX/>

---

 **NOTE:** If the web browser displays a message indicating that accessing the website might not be safe, select the option to continue to the website. Accessing this website will not harm the computer.

---

To use the HP Embedded Web Server, the browser must meet the following requirements:

### Windows® 7

- Internet Explorer (version 8.x or greater)
- Google Chrome (version 34.x or greater)
- Firefox (version 20.x or greater)

### Windows® 8 or greater

- Internet Explorer (version 9.x or greater)
- Google Chrome (version 34.x or greater)
- Firefox (version 20.x or greater)

### macOS

- Safari (version 5.x or greater)
- Google Chrome (version 34.x or greater)

### Linux

- Google Chrome (version 34.x or greater)
- Firefox (version 20.x or greater)

## HP Embedded Web Server features

Learn about the HP Embedded Web Server (EWS) features available on each tab.

- [Information tab](#)
- [General tab](#)
- [Print tab](#)
- [Supplies tab](#)
- [Troubleshooting tab](#)
- [Security tab](#)
- [HP Web Services tab](#)
- [Networking tab](#)
- [Other Links list](#)

### Information tab

Refer to the table for settings in the **Information** tab.

**Table 5-1** HP Embedded Web Server Information tab

Menu	Description
<b>Device Status</b>	Shows the printer status and shows the estimated life remaining of HP supplies. The page also shows the type and size of paper set for each tray. To change the default settings, click the <b>Change Settings</b> link.
<b>Configuration Page</b>	Shows the information found on the configuration page.
<b>Supplies Status Page</b>	Shows the status of the supplies for the printer.
<b>Event Log Page</b>	Shows a list of all printer events and errors. Use the <b>HP Instant Support</b> link (in the <b>Other Links</b> area on all HP Embedded Web Server pages) to connect to a set of dynamic web pages that help solve problems. These pages also show additional services available for the printer.
<b>Usage Page</b>	Shows a summary of the number of pages the printer has printed, grouped by size, type, and paper print path.
<b>Device Information</b>	Shows the printer network name, address, and model information. To customize these entries, click the <b>Device Information</b> menu on the <b>General</b> tab.
<b>Control Panel Snapshot</b>	Shows an image of the current screen on the control panel display.
<b>Printable Reports and Pages</b>	Lists the internal reports and pages for the printer. Select one or more items to print or view.
<b>Open Source Licenses</b>	Shows a summary of the licenses for open source software programs that can be used with the printer.

### General tab

Refer to the table for settings in the **General** tab.

**Table 5-2 HP Embedded Web Server General tab**

Menu	Description
Display Settings	Configure settings for sound, timeout for inactivity, clearable warnings, and continuable events.
Control Panel Language and Keyboard Layouts	Select the default language for control panel messages and the default keyboard layout for each language.
Alerts	Set up email alerts for various printer and supplies events.
Control Panel Settings App	Shows Settings app options that are available on the printer control panel.
General Settings	Configure how the printer recovers from jams and whether copy jobs initiated at the printer control panel take priority over print jobs.
AutoSend	Configure the printer to send automated emails regarding printer configuration and supplies to specific email addresses.
Edit Other Links	Add or customize a link to another website. This link displays in the footer area on all HP Embedded Web Server pages.
Ordering Information	Enter information about ordering replacement cartridges. This information displays on the supplies status page.
Device Information	Name the printer and assign an asset number to it. Enter the name of the primary contact who will receive information about the printer.
Language	Set the language in which to display the HP Embedded Web Server information.
Firmware Upgrade	Download and install printer firmware upgrade files.
Date/Time Settings	Set the date and time or synchronize with a network time server.
Energy Settings	Set or edit sleep settings that affect how much power the printer uses, the wake/sleep time, how quickly the printer enters sleep mode, and how quickly the printer wakes up from sleep mode.
Backup and Restore	Create a backup file that contains printer and user data. If necessary, use this file to restore data to the printer.
Reset Factory Settings	Restore printer settings to the factory defaults.
Solution Installer	Install third-party software packages that extend or modify the functionality of the printer.
Job Statistics Settings	Provides connection information about third-party job-statistics services.
Quota Settings	Provides connection information about third-party job-quota services.

## Print tab

Refer to the table for settings in the **Print** tab.

**Table 5-3 HP Embedded Web Server Print tab**

Menu	Description
Print from USB drive settings	Enable or disable the <a href="#">Print from USB Drive</a> menu on the control panel.
Manage Stored Jobs	Enable or disable the ability to store jobs in the printer memory. Configure job-storage options.
Default Print Options	Configure the default options for print jobs.

**Table 5-3** HP Embedded Web Server Print tab (continued)

Menu	Description
<b>Restrict Color</b>  (Color printers only)	Permit or restrict color printing.  Specify permissions for individual users or for jobs that are sent from specific software programs.
<b>PCL and PostScript Settings</b>	Adjust the PCL and PostScript settings for all print jobs.
<b>Print Quality</b>	Configure the print quality settings, including color adjustment, image registration, and allowed paper types.
<b>Manage Trays</b>	Configure settings for paper trays.

## Supplies tab

Refer to the table for settings in the **Supplies** tab.

**Table 5-4** HP Embedded Web Server Supplies tab

Menu	Description
<b>Manage Supplies</b>	Configure how the printer reacts when supplies reach a Very Low state.

## Troubleshooting tab

Refer to the table for settings in the **Troubleshooting** tab.

**Table 5-5** HP Embedded Web Server Troubleshooting tab

Menu	Description
<b>General Troubleshooting</b>	Select from a variety of reports and tests to help solve problems with the printer.
<b>Online Help</b>	Link to HP cloud-based online help to assist in troubleshooting printing issues.
<b>Diagnostic Data</b>	Export printer information to a file that can be useful for detailed problem analysis.  <b>NOTE:</b> This item is available only if an administrator password is set from the <b>Security</b> tab.
<b>Calibration/Cleaning</b>	Set cleaning and calibration settings, print a cleaning page, and perform a full or partial calibration.
<b>Reset Factory Settings</b>	Restore printer settings to factory defaults.
<b>Firmware Upgrade</b>	Download and install printer firmware upgrade files.

## Security tab

Refer to the table for settings in the **Security** tab.

**Table 5-6 HP Embedded Web Server Security tab**

Menu	Description
General Security	Settings for general security, including the following: <ul style="list-style-type: none"> <li>• Configure an administrator password to restrict access to certain features on the printer.</li> <li>• Set PJL password for processing PJL commands.</li> <li>• Set file system access and firmware upgrade security.</li> <li>• Enable or disable the Host USB port on the control panel or the USB connectivity port on the formatter for printing directly from a computer.</li> <li>• View the status of all security settings.</li> </ul>
Account Policy	Enable administrator account settings.
Access Control	Configure access to printer functions for specific individuals or groups, and select the method individuals use to sign in to the printer.
Protect Stored Data	Configure and manage the internal hard drive for the printer. This printer includes an encrypted hard drive for maximum security.  Configure settings for jobs that are stored on the printer hard drive.
Manage Remote Apps	Manage or whitelist remote apps by importing or deleting certificates that allow devices to use this product.
Certificate Management	Install and manage security certificates for access to the printer and the network.
Web Service Security	Allow resources on this printer to be accessed by web pages from different domains. If no sites are added to the list, then all sites are trusted.
Self Test	Verify that the security functions are running according to expected system parameters.

## HP Web Services tab

Use the **HP Web Services** tab to configure and enable HP Web Services for this printer. It is necessary to enable HP Web Services to use the HP ePrint feature.

**Table 5-7 HP Embedded Web Server HP Web Services tab**

Menu	Description
Web Services Setup	Connect this printer to HP Connected on the web by enabling HP Web Services.
Web Proxy	Configure a proxy server if there are issues enabling HP Web Services or connecting the printer to the Internet.
Smart Cloud Print	Enable Smart Cloud Print , which allows access to web-based apps that extend the capabilities of the printer.

## Networking tab

Use the **Networking** tab to configure and secure network settings for the printer when it is connected to an IP-based network. This tab does not display if the printer is connected to other types of networks.

**Table 5-8 HP Embedded Web Server Networking tab > Configuration settings**

Menu	Description
Wi-Fi Direct	Configure Wi-Fi Direct settings for printers that include embedded Wi-Fi Direct Print and NFC printing or that have a wireless accessory installed.  <b>NOTE:</b> The configuration options available depend on the print server model.
TCP/IP Settings	Configure TCP/IP settings for IPv4 and IPv6 networks.  <b>NOTE:</b> The configuration options available depend on the print server model.
Network Settings	Configure IPX/SPX, AppleTalk, DLC/LLC, and SNMP settings, depending on the print server model.
Other Settings	Configure general printing protocols and services supported by the print server. The available options depend on the print server model, but can include firmware update, LPD queues, USB settings, support information, and refresh rate.
AirPrint	Enable, set up, or disable network printing from Apple-supported printers.
Select Language	Change the language displayed by the HP Embedded Web Server. This page displays if the web pages support multiple languages. Optionally, select supported languages through language-preference settings in the browser.
Select Location	Select a country/region for the printer.

**Table 5-9 HP Embedded Web Server Networking tab > Google Cloud Print settings**

Menu	Description
Setup	Set up Google Cloud Print options.
Web Proxy	Configure proxy settings.

**Table 5-10 HP Embedded Web Server Networking tab > Security settings**

Menu	Description
Settings	View and restore current security settings to factory-default values.  Configure security settings using the Security Configuration Wizard.  <b>NOTE:</b> Do not use the Security Configuration Wizard to configure security settings using network-management applications, such as HP Web Jetadmin.
Authorization	Control configuration management and use of this printer, including the following: <ul style="list-style-type: none"> <li>Set or change the administrator password to control access to configuration parameters.</li> <li>Request, install, and manage digital certificates on the HP Jetdirect print server.</li> <li>Limit host access to this printer through an Access Control List (ACL) (for selected print servers on IPv4 networks only).</li> </ul>
Secure Communication	Configure security settings.



**Table 5-10 HP Embedded Web Server Networking tab > Security settings (continued)**

Menu	Description
Mgmt. Protocols	Configure and manage security protocols for this printer, including the following: <ul style="list-style-type: none"> <li>Set the security management level for the HP Embedded Web Server, and control traffic over HTTP and HTTPS.</li> <li>Configure the SNMP (Simple Network Management Protocol) operation. Enable or disable the SNMP v1/v2c or SNMP v3 agents on the print server.</li> <li>Control access through protocols that may not be secure, such as printing protocols, print services, discovery protocols, name resolution services, and configuration-management protocols.</li> </ul>
802.1X Authentication	Configure 802.1X authentication settings on the Jetdirect print server as required for client authentication on the network, and reset the 802.1X authentication settings to factory-default values. <p><b>CAUTION:</b> When changing the 802.1X authentication settings; the printer might lose its connection. To reconnect, it might be necessary to reset the print server to a factory-default state and reinstall the printer.</p>
IPsec/Firewall	View or configure a Firewall policy or an IPsec/Firewall policy.
Announcement Agent	Enable or disable the HP Device Announcement Agent, set the configuration server, and configure mutual authentication using certificates.

**Table 5-11 HP Embedded Web Server Networking tab > Diagnostics settings**

Menu	Description
Network Statistics	Display network statistics that are collected and stored on the HP Jetdirect print server.
Protocol Info	View a list of network-configuration settings on the HP Jetdirect print server for each protocol.
Configuration Page	View the HP Jetdirect configuration page, which contains status and configuration information.

## Other Links list

Configure which links display in the footer of the HP Embedded Web Server by using the **Edit Other Links** menu on the **General** tab.

 **NOTE:** Configure which links display in the footer of the HP Embedded Web Server by using the **Edit Other Links** menu on the **General** tab. The following are the default links.

**Table 5-12 HP Embedded Web Server Other Links list**

Menu	Description
HP Instant Support	Connect to the HP website to find solutions to printer problems.
Shop for Supplies	Connect to the HP SureSupply website for information on purchasing original HP supplies, such as cartridges and paper.
Product Support	Connect to the support site for the printer to search for help on various topics.

# Configure IP network settings

Use the EWS to configure the printer network settings.

- [Printer sharing disclaimer](#)
- [View or change network settings](#)
- [Rename the printer on a network](#)
- [Manually configure IPv4 TCP/IP parameters from the control panel](#)
- [Manually configure IPv6 TCP/IP parameters from the control panel](#)
- [Link speed and duplex settings](#)



## Printer sharing disclaimer

Review the following disclaimer.

HP does not support peer-to-peer networking, as the feature is a function of Microsoft operating systems and not of the HP printer drivers. Go to Microsoft at [www.microsoft.com](http://www.microsoft.com).

## View or change network settings

Use the HP Embedded Web Server to view or change IP configuration settings.

1. Open the HP Embedded Web Server (EWS):
  - a. From the Home screen on the printer control panel, touch the Information icon , and then touch the Ethernet icon  to display the IP address or host name.
  - b. Open a web browser, and in the address line, type the IP address or host name exactly as it displays on the printer control panel. Press the **Enter** key on the computer keyboard. The EWS opens.

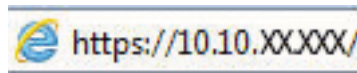



 **NOTE:** If the web browser displays a message indicating that accessing the website might not be safe, select the option to continue to the website. Accessing this website will not harm the computer.

2. Click the **Networking** tab to obtain network information. Change settings as needed.

## Rename the printer on a network

To rename the printer on a network so that it can be uniquely identified, use the HP Embedded Web Server.

1. Open the HP Embedded Web Server (EWS):
  - a. From the Home screen on the printer control panel, touch the Information icon , and then touch the Ethernet icon  to display the IP address or host name.

- b. Open a web browser, and in the address line, type the IP address or host name exactly as it displays on the printer control panel. Press the **Enter** key on the computer keyboard. The EWS opens.

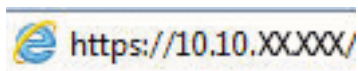

 **NOTE:** If the web browser displays a message indicating that accessing the website might not be safe, select the option to continue to the website. Accessing this website will not harm the computer.

2. Open the **General** tab.
3. On the Device Information page, the default printer name is in the **Device Name** field. You can change this name to uniquely identify this printer.

 **NOTE:** Completing the other fields on this page is optional.

4. Click the **Apply** button to save the changes.

## Manually configure IPv4 TCP/IP parameters from the control panel

Use the control-panel [Settings](#) menus to manually set an IPv4 address, subnet mask, and default gateway.

1. From the Home screen on the printer control panel, navigate to the [Settings](#) application, and then select the [Settings](#) icon.
2. Open the following menus:
  - a. [Networking](#)
  - b. [Ethernet](#)
  - c. [TCP/IP](#)
  - d. [IPV 4 Settings](#)
  - e. [Config Method](#)
3. Select the [Manual](#) option, and then touch the [Save](#) button.
4. Open the [Manual Settings](#) menu.
5. Touch the [IP Address](#), [Subnet Mask](#), or [Default Gateway](#) option.
6. Touch the first field to open a keypad. Enter the correct digits for the field, and then touch the [OK](#) button.  
Repeat the process for each field, and then touch the [Save](#) button.

## Manually configure IPv6 TCP/IP parameters from the control panel

Use the control-panel [Settings](#) menus to manually set an IPv6 address.

1. From the Home screen on the printer control panel, navigate to the [Settings](#) application, and then select the [Settings](#) icon.
2. To enable manual configuration, open the following menus:
  - a. [Networking](#)
  - b. [Ethernet](#)

- c. [TCP/IP](#)
  - d. [IPV6 Settings](#)
3. Select [Enable](#), and then select [On](#).
4. Select the [Enable Manual Settings](#) option, and then touch the [Done](#) button.
5. To configure the address, open the [Address](#) menu, and then touch the field to open a keypad.
6. Use the keypad to enter the address, and then touch the [OK](#) button.
7. Touch [Save](#).

## Link speed and duplex settings

Use the following steps to make changes to link speed and duplex settings.

---

 **NOTE:** This information applies only to Ethernet networks. It does not apply to wireless networks.

---

The link speed and communication mode of the print server must match the network hub. For most situations, leave the printer in automatic mode. Incorrect changes to the link speed and duplex settings might prevent the printer from communicating with other network devices. To make changes, use the printer control panel.

---

 **NOTE:** The printer setting must match the setting for the network device (a network hub, switch, gateway, router, or computer).

---

 **NOTE:** Making changes to these settings causes the printer to turn off and then on. Make changes only when the printer is idle.

---

1. From the Home screen on the printer control panel, navigate to the [Settings](#) application, and then select the [Settings](#) icon.
2. Open the following menus:
  - a. [Networking](#)
  - b. [Ethernet](#)
  - c. [Link Speed](#)
3. Select one of the following options:
  - [Auto](#): The print server automatically configures itself for the highest link speed and communication mode allowed on the network.
  - [10T Half](#): 10 megabytes per second (Mbps), half-duplex operation
  - [10T Full](#): 10 Mbps, full-duplex operation
  - [10T Auto](#): 10 Mbps, automatic-duplex operation
  - [100TX Half](#): 100 Mbps, half-duplex operation
  - [100TX Full](#): 100 Mbps, full-duplex operation

- [100TX Auto](#): 100 Mbps, automatic-duplex operation
  - [1000T Full](#): 1000 Mbps, full-duplex operation
4. Touch the [Save](#) button. The printer turns off and then on.

# Printer security features

Restrict who has access to configuration settings, secure data, and prevent access to valuable hardware components.

- [Introduction](#)
- [Security statements](#)
- [Assign an administrator password](#)
- [IP Security](#)
- [Encryption support: HP High Performance Secure Hard Disks](#)
- [Lock the formatter](#)

## Introduction

The printer includes several security features to restrict who has access to configuration settings, to secure data, and to prevent access to valuable hardware components.

## Security statements

Review this important security statement.

The printer supports security standards and recommended protocols that help you keep the printer secure, protect critical information on your network, and simplify the way you monitor and maintain the printer.



## Assign an administrator password

Assign an administrator password for access to the printer and the HP Embedded Web Server so that unauthorized users cannot change the printer settings.

- [Use the HP Embedded Web Server \(EWS\) to set the password](#)
- [Provide user access credentials at the printer control panel](#)

### Use the HP Embedded Web Server (EWS) to set the password

Use the following steps to set a password for the printer.

1. Open the HP Embedded Web Server (EWS):
  - a. From the Home screen on the printer control panel, touch the Information icon , and then touch the Ethernet icon  to display the IP address or host name.
  - b. Open a web browser, and in the address line, type the IP address or host name exactly as it displays on the printer control panel. Press the Enter key on the computer keyboard. The EWS opens.

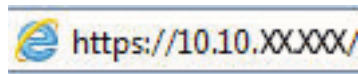

 **NOTE:** If the web browser displays a message indicating that accessing the website might not be safe, select the option to continue to the website. Accessing this website will not harm the computer.

2. Click the **Security** tab.
3. Open the **General Security** menu.
4. In the area labeled **Set the Local Administrator Password**, enter the name to associate with the password in the **Username** field.
5. Enter the password in the **New Password** field, and then enter it again in the **Verify Password** field.

 **NOTE:** To change an existing password, first enter the existing password in the **Old Password** field.

6. Click the **Apply** button.

 **IMPORTANT:** Make note of the password and store it in a safe place. The administrator password cannot be recovered. If the administrator password is lost or forgotten, contact HP Support for the assistance required to completely reset the printer.

[Click here to contact HP Support about resetting the printer password.](#)

### Provide user access credentials at the printer control panel

Use the following steps to sign into the control panel.

Some features on the printer control panel can be secured so that unauthorized people cannot use them. When a feature is secured, the printer prompts you to sign in before you can use it. You can also sign in without waiting for a prompt by selecting [Sign In](#) from the printer control panel.

Typically, the credentials for signing in to the printer are the same as for signing in to the network. Consult the network administrator for this printer if you have questions about which credentials to use.

1. From the Home screen on the printer control panel, select [Sign In](#).
2. Follow the prompts to enter the credentials.



---

**NOTE:** To maintain security for the printer, select [Sign Out](#) when you have finished using the printer.

---

## IP Security

IP Security (IPsec) is a set of protocols that control IP-based network traffic to and from the printer. IPsec provides host-to-host authentication, data integrity, and encryption of network communications.

For printers that are connected to the network and have an HP Jetdirect print server, you can configure IPsec by using the **Networking** tab in the HP Embedded Web Server.

## Encryption support: HP High Performance Secure Hard Disks

The hard disk provides hardware-based encryption so you can securely store sensitive data without impacting printer performance. This hard disk uses the latest Advanced Encryption Standard (AES) and has versatile time-saving features and robust functionality.

Use the **Security** menu in the HP Embedded Web Server to configure the disk.

## Lock the formatter

The formatter has a slot that you can use to attach a security cable.

Locking the formatter prevents someone from removing valuable components from it.



# Energy-conservation settings

Learn about the energy-conservation settings that are available for the printer.

- [Set the sleep timer and configure the printer to use 1 watt or less of power](#)
- [Set the sleep schedule](#)
- [Set the idle settings](#)

## Set the sleep timer and configure the printer to use 1 watt or less of power

The sleep settings affect how much power the printer uses, the wake/sleep time, how quickly the printer enters sleep mode, and how quickly the printer wakes up from sleep mode.

To configure the printer to use 1 watt or less of power while in sleep mode, enter times for both the [Sleep after Inactivity](#) and [Auto Off after sleep](#) settings.

---

 **NOTE:** HP does not recommend using deep sleep settings if you have Security Solutions installed. In some situations, the printer does not wake from deep sleep. For additional information, contact your HP representative.

---

1. From the Home screen on the printer control panel, navigate to the [Settings](#) application, and then select the [Settings](#) icon.
2. Open the following menus:
  - a. [General](#)
  - b. [Energy Settings](#)
  - c. [Sleep Settings](#)
3. Select [Sleep after Inactivity](#) to specify the number of minutes the printer is inactive before it enters sleep mode. Enter the appropriate time period.
4. Select [Auto Off after sleep](#) to put the printer into a deeper power save mode after a period of sleep. Enter the appropriate time period.

---

 **NOTE:** By default, the printer will wake from Auto Off in response to any activity other than USB or Wi-Fi. For greater energy settings, you can set it to wake only to the power button by selecting [Shut down \(wake on power button only\)](#).

---

5. Select [Done](#) to save the settings.

## Set the sleep schedule

Use the [Sleep Schedule](#) feature to configure the printer to automatically wake or go into Sleep mode at specific times on specific days of the week.

1. From the Home screen on the printer control panel, navigate to the [Settings](#) application, and then select the [Settings](#) icon.
2. Open the following menus:

- a. [General](#)
  - b. [Energy Settings](#)
  - c. [Sleep Schedule](#)
3. Select the [New Event](#) button, and then select the type of event to schedule: [Wake Event](#) or [Sleep Event](#).
4. For a wake or sleep event, configure the time and the days of the week for the event. Select [Save](#) to save the setting.

## Set the idle settings

This setting affects energy use while the product is idle, not while in Sleep Mode. [Start faster](#) results in a quicker first-page-out time, but uses more power. [Save energy](#) conserves power, but could result in a slower first-page-out time.

1. From the Home screen on the printer control panel, open the [Settings](#) menu.
2. Open the following menus:
  - a. [General](#)
  - b. [Energy Settings](#)
  - c. [Idle Settings](#)
3. Adjust the slider, and then select [Done](#) to save the setting.

## HP Web Jetadmin

HP Web Jetadmin is an award-winning, industry-leading tool for efficiently managing a wide variety of networked HP products, including printers, multifunction printers, and digital senders. This single solution allows you to remotely install, monitor, maintain, troubleshoot, and secure your printing and imaging environment — ultimately increasing business productivity by helping you save time, control costs, and protect your investment.

HP Web Jetadmin upgrades are periodically made available to provide support for specific product features. Go to [www.hp.com/go/webjetadmin](http://www.hp.com/go/webjetadmin) for more information.

---

# 6 Solve problems

Troubleshoot problems with the printer. Locate additional resources for help and technical support.

- [Customer support](#)
- [Control panel help system](#)
- [Reset factory settings](#)
- [A “Cartridge is low” or “Cartridge is very low” message displays on the printer control panel](#)
- [Printer does not pick up paper or misfeeds](#)
- [Clear paper jams](#)
- [Resolving color print quality problems](#)
- [Solve wired network problems](#)

For video assistance, see [www.hp.com/videos/LaserJet](http://www.hp.com/videos/LaserJet).

The following information is correct at the time of publication. For current information, see [www.hp.com/support/colorljE85055](http://www.hp.com/support/colorljE85055).

## For more information:

HP's all-inclusive help for the printer includes the following information:

- Install and configure
- Learn and use
- Solve problems
- Download software and firmware updates
- Join support forums
- Find warranty and regulatory information

## Customer support

Find support contact options for your HP printer.

**Table 6-1** Customer support options

Support option	Location
Get telephone support for your country/region.  Have the printer name, serial number, date of purchase, and problem description ready.	Country/region phone numbers are on the flyer that was in the box with the printer or at <a href="http://support.hp.com">support.hp.com</a> .
Get 24-hour Internet support, and download software utilities and drivers.	<a href="http://www.hp.com/support/colorliE85055">www.hp.com/support/colorliE85055</a>
Order additional HP service or maintenance agreements.	<a href="http://www.hp.com/go/carepack">www.hp.com/go/carepack</a>
Register the printer.	<a href="http://www.register.hp.com">www.register.hp.com</a>

## Control panel help system

The printer has a built-in Help system that explains how to use each screen. To open the Help system, touch the Help button  in the upper-right corner of the screen.



For some screens, the Help opens to a global menu where you can search for specific topics. You can browse through the menu structure by touching the buttons in the menu.

Some Help screens include animations that show specific procedures, such as clearing paper jams.

If the printer alerts of an error or warning, touch the Help button  to open a message that describes the problem. The message also contains instructions to help solve the problem.

# Reset factory settings

Resetting the printer settings to the factory-set defaults can help resolve problems.

- [Introduction](#)
- [Method one: Reset factory settings from the printer control panel](#)
- [Method two: Reset factory settings from the HP Embedded Web Server \(network-connected printers only\)](#)

## Introduction

Use one of the following methods to reset the printer settings to the original settings from the factory.

### Method one: Reset factory settings from the printer control panel

Use the printer control panel to restore the settings to their original values.

1. From the Home screen on the printer control panel, navigate to the [Settings](#) application, and then select the [Settings](#) icon.
2. Open the following menus:
  - a. [General](#)
  - b. [Reset Factory Settings](#)
3. Select [Reset](#).

A verification message advises that completing the reset function might result in loss of data.

4. Select [Reset](#) to complete the process.





---

**NOTE:** The printer restarts automatically after the reset operation completes.

---

### Method two: Reset factory settings from the HP Embedded Web Server (network-connected printers only)

Use the HP EWS to reset the printer settings to the original settings.

1. On the printer control panel, select the Information button , and then select the Network icon  to display the IP address or host name.
2. Open the **General** tab.
3. On the left side of the screen, click **Reset Factory Settings**.
4. Click the **Reset** button.



---

**NOTE:** The printer restarts automatically after the reset operation completes.

---

## A “Cartridge is low” or “Cartridge is very low” message displays on the printer control panel

Review the possible solutions to this issue.

**Cartridge is low:** The printer indicates when a toner cartridge level is low. Actual toner cartridge life remaining may vary. Consider having a replacement available to install when print quality is no longer acceptable. The toner cartridge does not need to be replaced now.

**Cartridge is very low:** The printer indicates when the toner cartridge level is very low. Actual toner cartridge life remaining may vary. Consider having a replacement available to install when print quality is no longer acceptable. The toner cartridge does not need to be replaced now unless the print quality is no longer acceptable.

HP's Premium Protection Warranty expires near the end of useable cartridge life. Check the Supplies Status Page or the HP Embedded Web Server (EWS) for the status.

# Printer does not pick up paper or misfeeds

Use this information if the printer is not picking up paper from the tray or is picking up multiple sheets of paper at one time.

- [Introduction](#)
- [The printer does not pick up paper](#)
- [The printer picks up multiple sheets of paper](#)

## Introduction

The following solutions can help solve problems if the printer is not picking up paper from the tray or is picking up multiple sheets of paper at one time. Either of these situations can result in paper jams.

## The printer does not pick up paper

If the printer does not pick up paper from the tray, try these solutions:

1. Open the printer and remove any jammed sheets of paper. Verify that no torn remnants of paper remain inside the printer.
2. Load the tray with the correct size of paper for the job.
3. Make sure the paper size and type are set correctly on the printer control panel.

4. Make sure the paper guides in the tray are adjusted correctly for the size of paper. Adjust the guides to the appropriate indentation in the tray. The arrow on the tray guide should line up exactly with the marking on the tray.

 **NOTE:** Do not adjust the paper guides tightly against the paper stack. Adjust them to the indentations or markings in the tray.

The following images show examples of the paper-size indentations in the trays for various printers. Most HP printers have markings similar to these.

**Figure 6-1** Size markings for Tray 1 or the multipurpose tray

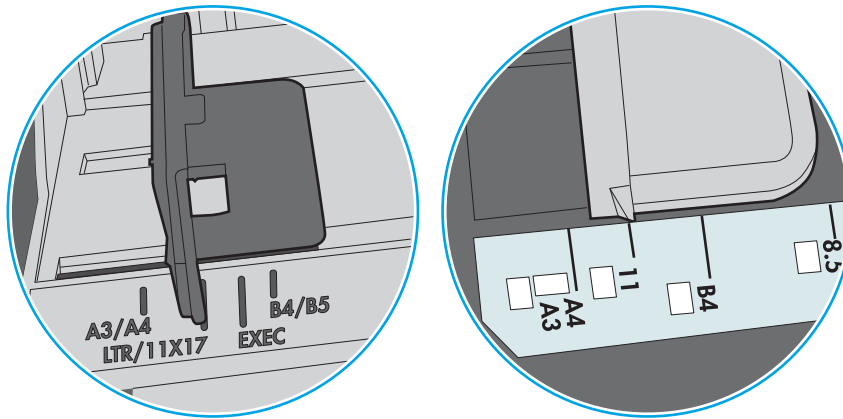

**Figure 6-2** Size markings for cassette trays

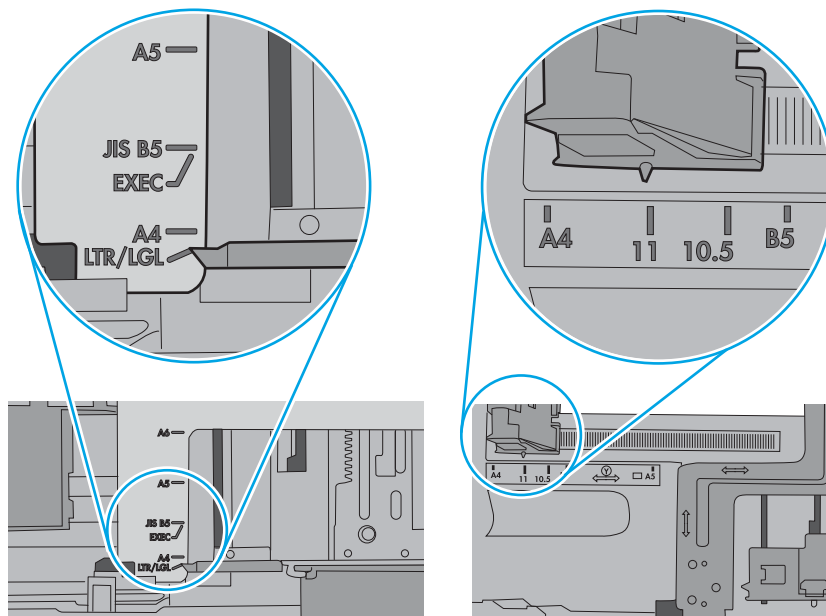



5. Verify that the humidity in the room is within specifications for this printer and that paper is being stored in unopened packages. Most reams of paper are sold in moisture-proof wrapping to keep paper dry.

In high-humidity environments, paper at the top of the stack in the tray can absorb moisture, and it might have a wavy or uneven appearance. If this happens, remove the top 5 to 10 sheets of paper from the stack.

In low-humidity environments, excess static electricity can cause sheets of paper to stick together. If this happens, remove the paper from the tray, and flex the stack by holding it at each end and bringing the ends up to form a U shape. Then, rotate the ends down to reverse the U shape. Next, hold each side of the stack of paper and repeat this process. This process releases individual sheets without introducing static electricity. Straighten the paper stack against a table before returning it to the tray.

**Figure 6-3** Technique for flexing the paper stack

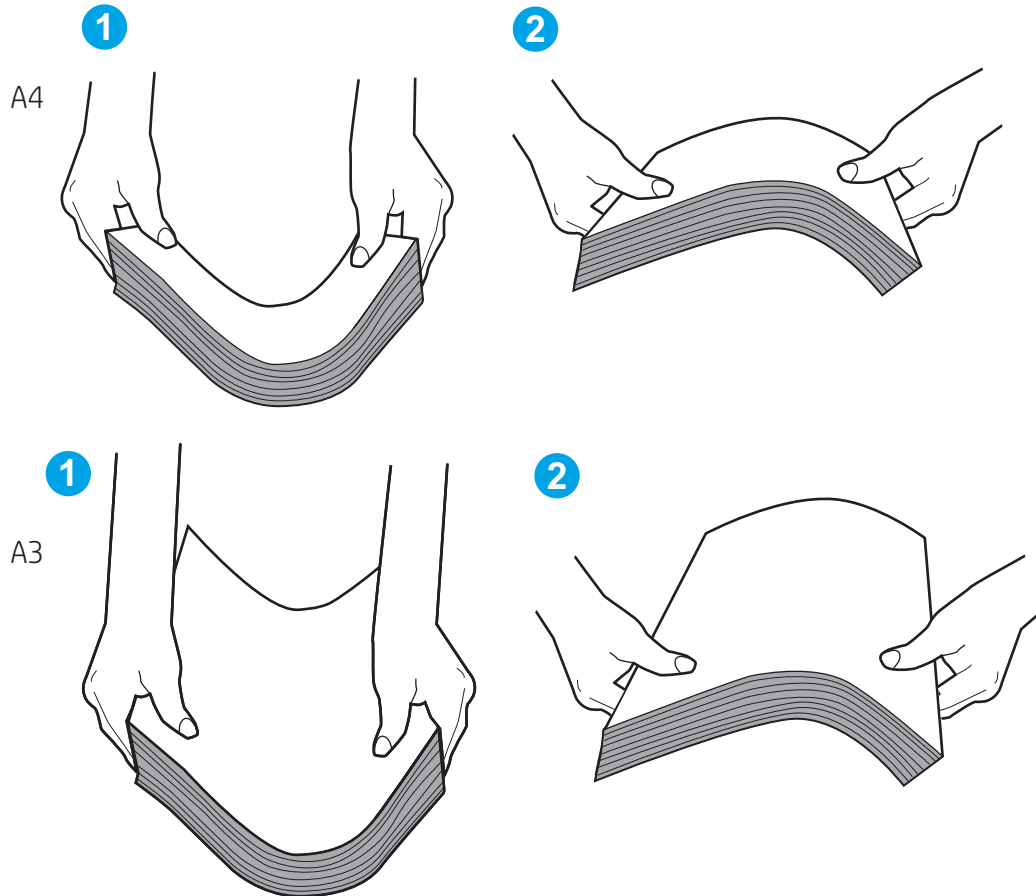

6. Check the printer control panel to see if it is displaying a prompt to feed the paper manually. Load paper, and continue.

7. The rollers above the tray might be contaminated. Clean the rollers with a lint-free cloth dampened with warm water. Use distilled water, if it is available.

---

**⚠ CAUTION:** Do not spray water directly onto the printer. Instead, spray water on the cloth or dab the cloth in water and wring it out before cleaning the rollers.

---

The following image shows examples of the roller location for various printers.

**Figure 6-4** Roller locations for Tray 1 or the multipurpose tray

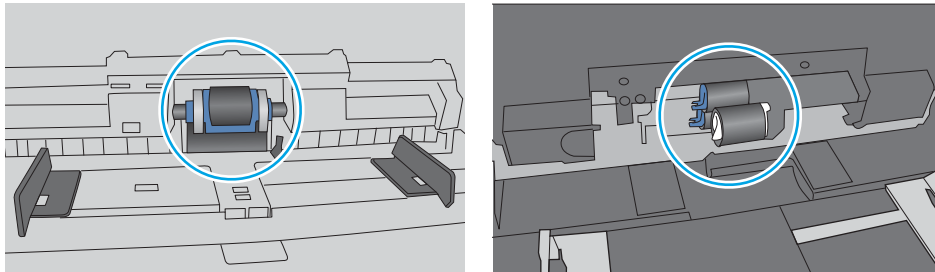

## The printer picks up multiple sheets of paper

If the printer picks up multiple sheets of paper from the tray, try these solutions:

1. Remove the stack of paper from the tray and flex it, rotate it 180 degrees, and flip it over. *Do not fan the paper.* Return the stack of paper to the tray.

---

**📝 NOTE:** Fanning the paper introduces static electricity. Instead of fanning the paper, flex the stack by holding it at each end and bringing the ends up to form a U shape. Then, rotate the ends down to reverse the U shape. Next, hold each side of the stack of paper and repeat this process. This process releases individual sheets without introducing static electricity. Straighten the paper stack against a table before returning it to the tray.

---

Figure 6-5 Technique for flexing the paper stack

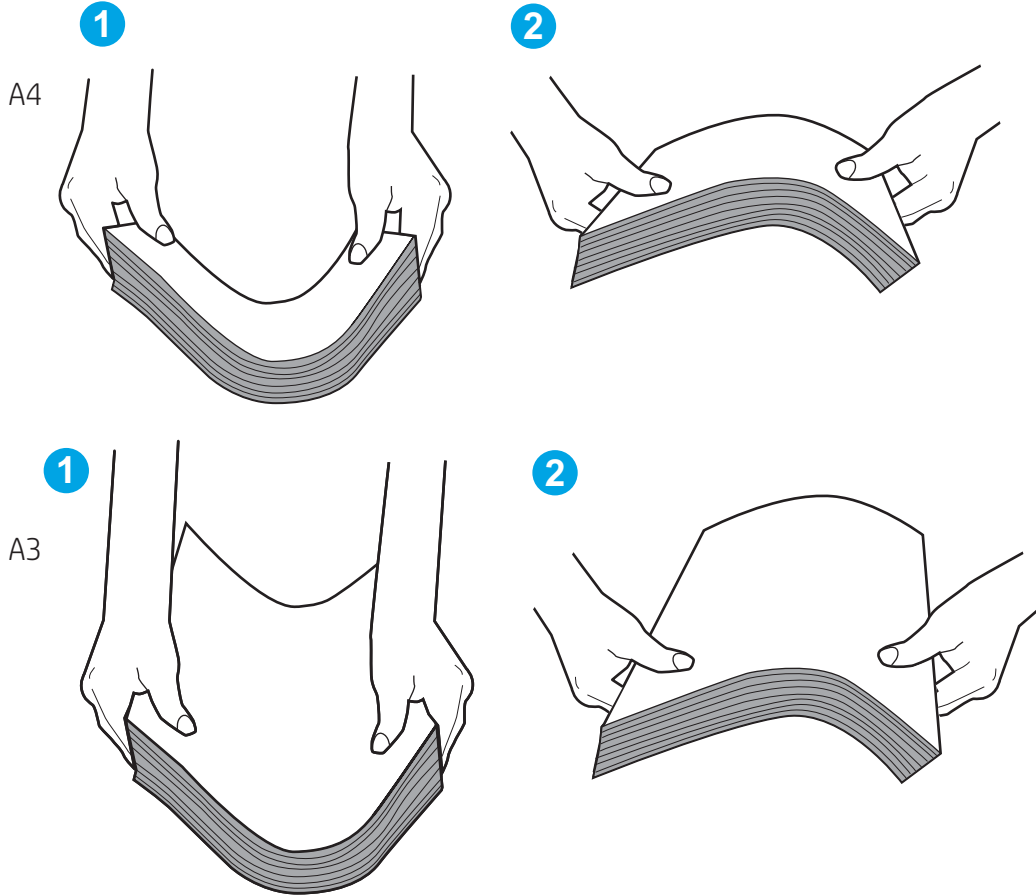

2. Use only paper that meets HP specifications for this printer.
3. Verify that the humidity in the room is within specifications for this printer, and that paper is being stored in unopened packages. Most reams of paper are sold in moisture-proof wrapping to keep paper dry.

In high-humidity environments, paper at the top of the stack in the tray can absorb moisture, and it might have a wavy or uneven appearance. If this happens, remove the top 5 to 10 sheets of paper from the stack.

In low-humidity environments, excess static electricity can cause sheets of paper to stick together. If this happens, remove the paper from the tray and flex the stack as described above.

4. Use paper that is not wrinkled, folded, or damaged. If necessary, use paper from a different package.

5. Make sure the tray is not overfilled by checking the stack-height markings inside the tray. If it is overfilled, remove the entire stack of paper from the tray, straighten the stack, and then return some of the paper to the tray.

The following examples show the stack-height markings in the trays for various printers. Most HP printers have markings similar to these. Also make sure that all sheets of paper are below the tabs near the stack-height marks. These tabs help hold the paper in the correct position as it enters the printer.

**Figure 6-6** Stack-height markings

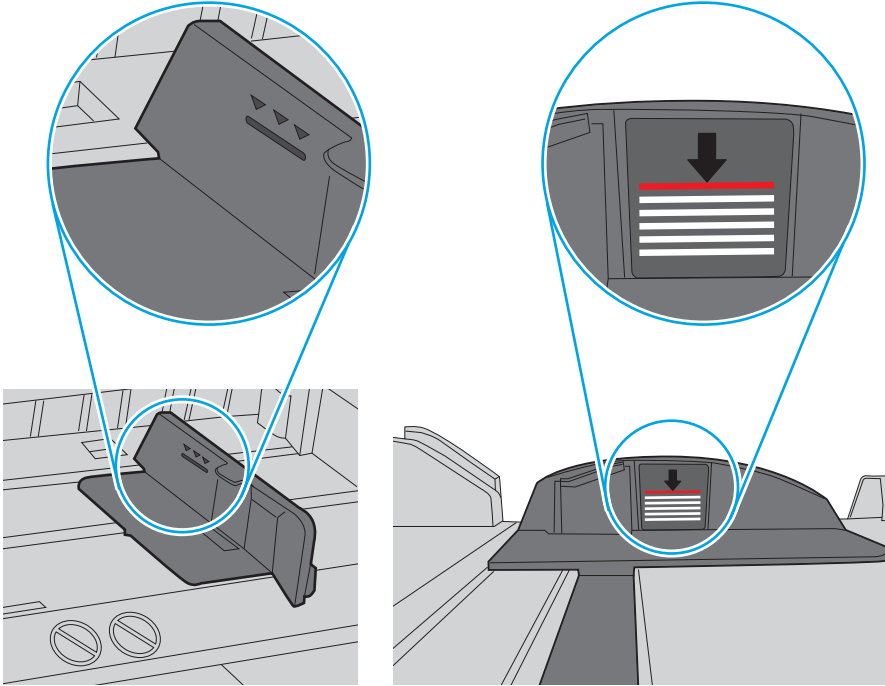

**Figure 6-7** Tab for the paper stack

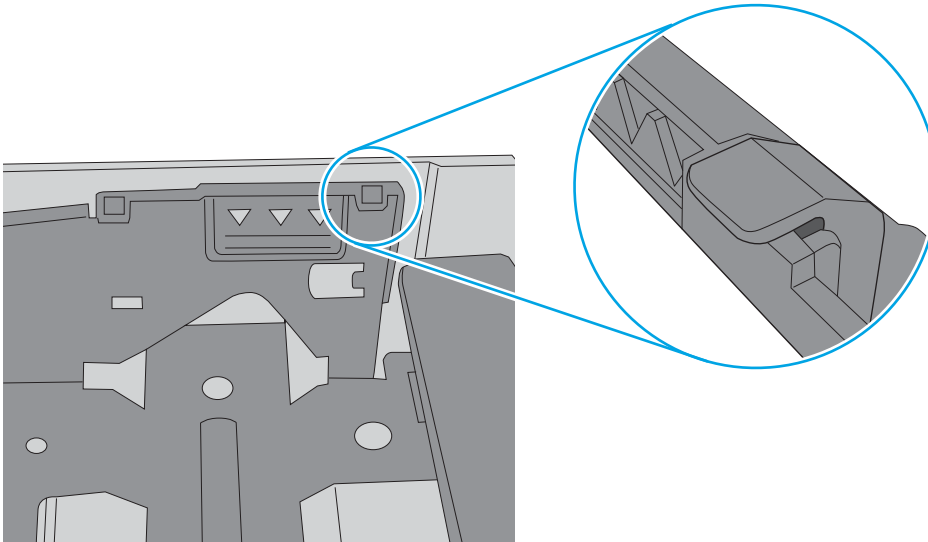

6. Make sure the paper guides in the tray are adjusted correctly for the size of paper. Adjust the guides to the appropriate indentation in the tray. The arrow on the tray guide should line up exactly with the marking on the tray.

 **NOTE:** Do not adjust the paper guides tightly against the paper stack. Adjust them to the indentations or markings in the tray.

The following images show examples of the paper-size indentations in the trays for various printers. Most HP printers have markings similar to these.

**Figure 6-8** Size markings for Tray 1 or the multipurpose tray

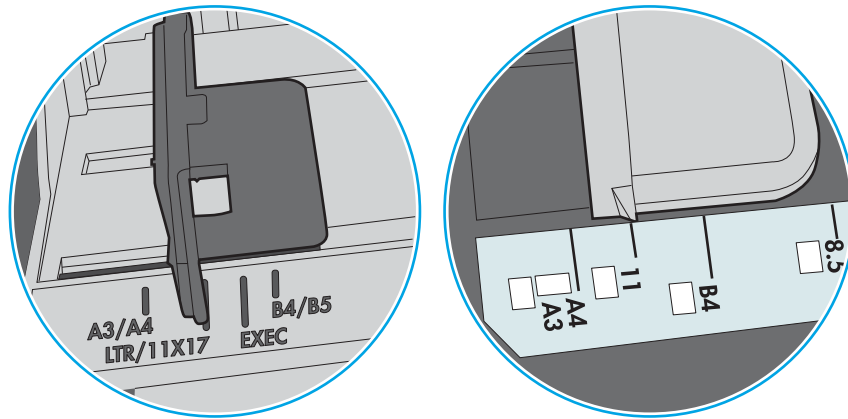

**Figure 6-9** Size markings for cassette trays

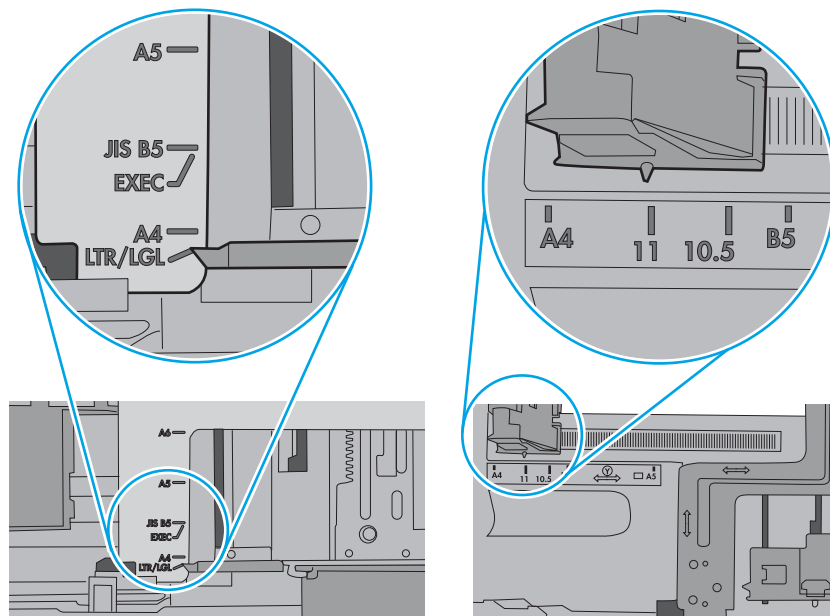

7. Make sure the printing environment is within recommended specifications.

# Clear paper jams

Use the procedures in this section to clear jammed paper from the printer paper path.

- [Introduction](#)
- [Paper jam locations](#)
- [Auto-navigation for clearing paper jams](#)
- [Experiencing frequent or recurring paper jams?](#)
- [Clear paper jams in Tray 1 \(13.A1\)](#)
- [Clear paper jams in Tray 2 \(13.A2\)](#)
- [Clear paper jams in the fuser \(13.B9, 13.B2, 13.FF\)](#)
- [Clear paper jams in the output bin \(13.E1\)](#)
- [Clear paper jams in the duplex area \(13.D3\)](#)
- [Clear paper jams in the 550-sheet trays \(13.A3, 13.A4\)](#)
- [Clear paper jams in the 2 x 550 paper trays \(13.A4, 13.A5\)](#)
- [Clear paper jams in the 2,700-sheet high-capacity input paper trays \(13.A3, 13.A4, 13.A5, 13.A7\)](#)

## Introduction

The following information includes instructions for clearing paper jams from the printer.

## Paper jam locations

Jams can occur in these locations.

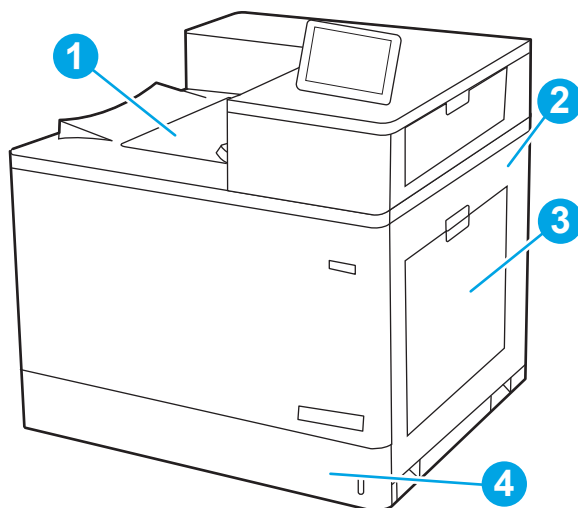

Number	Description
1	Output bin
2	Right door and fuser area

Number	Description
3	Tray 1
4	Tray 2

## Auto-navigation for clearing paper jams

The auto-navigation feature assists in clearing jams by providing step-by-step instructions on the control panel.

When you complete a step, the printer displays instructions for the next step until you have completed all steps in the procedure.

## Experiencing frequent or recurring paper jams?

To reduce the number of paper jams, try these solutions.



**NOTE:** [View a video that demonstrates how to load paper in a way that reduces the number of paper jams.](#)

1. Use only paper that meets HP specifications for this printer.
2. Use paper that is not wrinkled, folded, or damaged. If necessary, use paper from a different package.
3. Use paper that has not previously been printed or copied on.
4. Make sure the tray is not overfilled. If it is, remove the entire stack of paper from the tray, straighten the stack, and then return some of the paper to the tray.
5. Make sure the paper guides in the tray are adjusted correctly for the size of paper. Adjust the guides so they are touching the paper stack without bending it.
6. Make sure that the tray is fully inserted in the printer.
7. If you are printing on heavy, embossed, or perforated paper, use the manual feed feature and feed sheets one at a time.
8. Open the [Trays](#) menu on the printer control panel. Verify that the tray is configured correctly for the paper type and size.
9. Make sure the printing environment is within recommended specifications.

## Clear paper jams in Tray 1 (13.A1)

Use the following procedure to check for paper in all possible jam locations related to Tray 1 and inside the right door.

When a jam occurs, the control panel might display a message and an animation that assists in clearing the jam.

- **13.A1.XX Jam in Tray 1**

1. If jammed paper is visible in Tray 1, clear the jam by gently pulling the paper straight out.

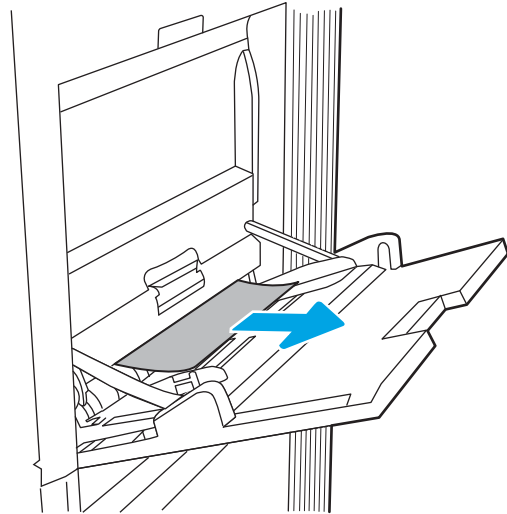

2. If you cannot remove the paper, or if no jammed paper is visible in Tray 1, close Tray 1 and open the right door.

**CAUTION:** Do not touch the transfer roller. Contaminants can affect print quality.

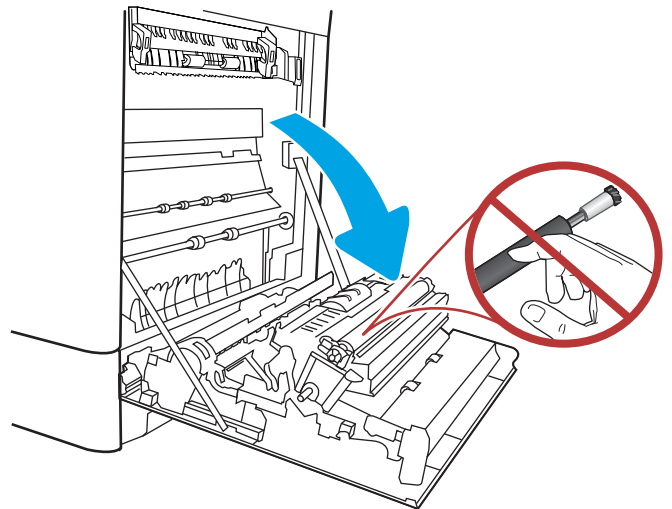

3. Gently pull out any jammed paper.

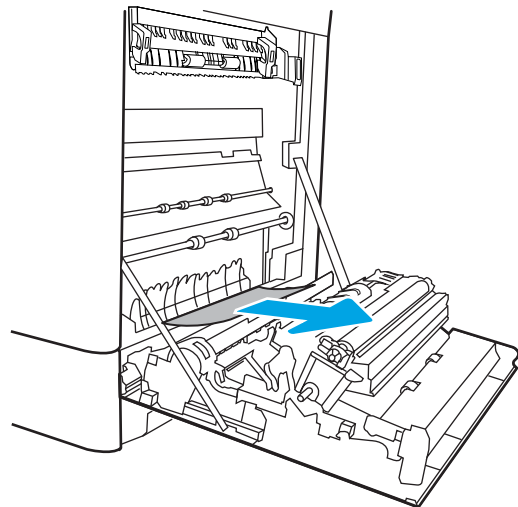



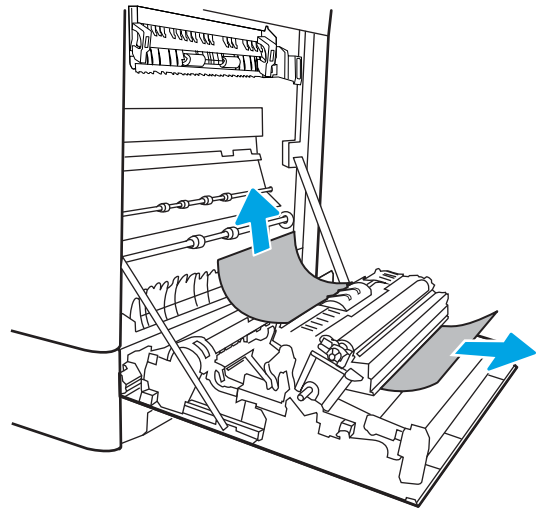

4. Gently pull out any jammed paper in the duplex area on the right door.

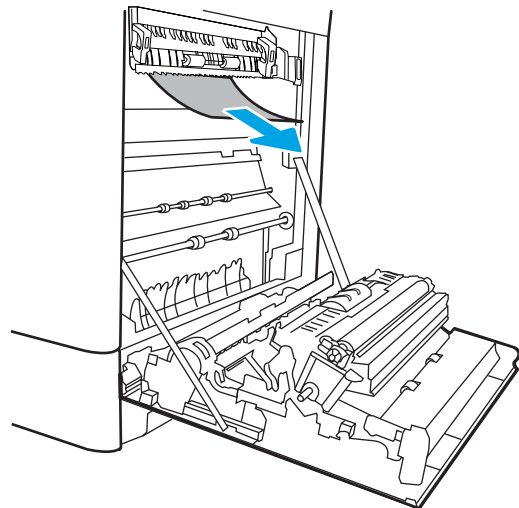

5. If paper is visible entering the bottom of the fuser, gently pull downward to remove it.



6. Paper could be jammed inside the fuser where it would not be visible. Grasp the fuser handles, squeeze the release levers, lift up slightly, and then pull straight out to remove the fuser.

**NOTE:**  The fuser can be hot while the printer is in use. Wait for the fuser to cool before handling it.

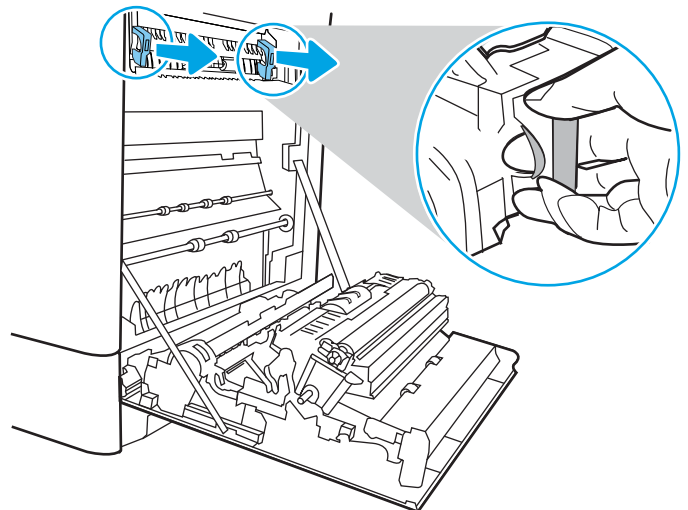

7. Open the jam-access door on the fuser. If paper is jammed inside the fuser, gently pull it straight up to remove it. If the paper tears, remove all paper fragments.

**CAUTION:**  Even if the body of the fuser has cooled, the rollers that are inside could still be hot. Do not touch the fuser rollers.

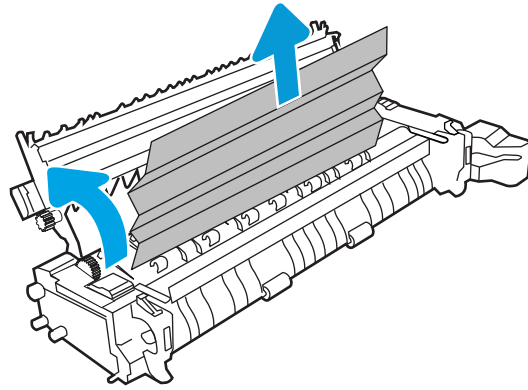

8. If paper is jammed as it enters the output bin, gently pull the paper out to remove it.

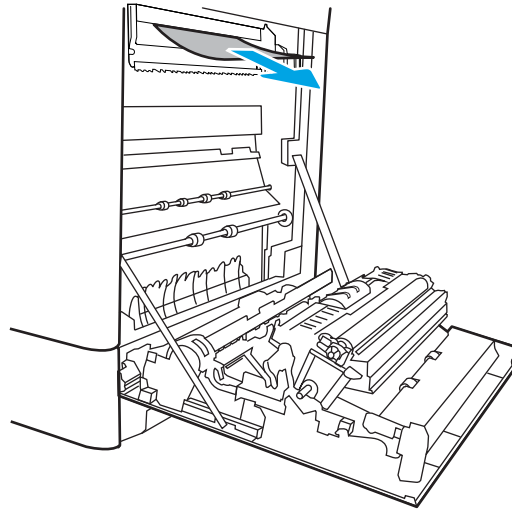

9. Close the jam-access door on the fuser, and push the fuser completely into the printer until it clicks into place.

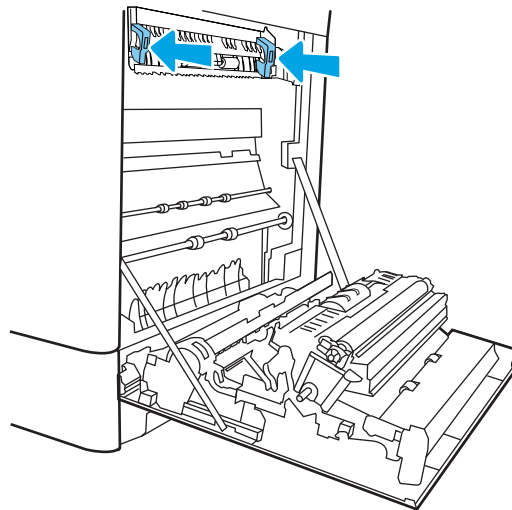

10. Close the right door.

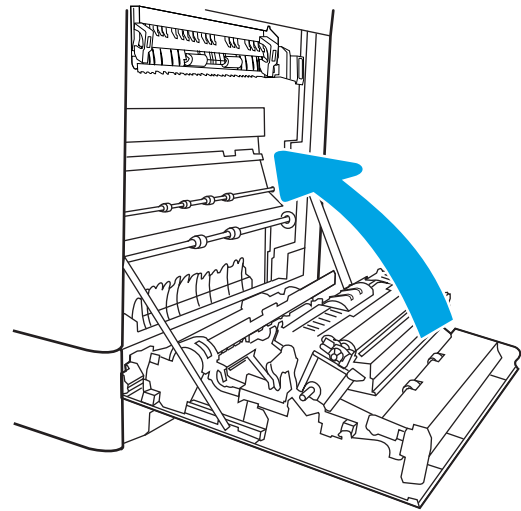

11. Open the upper-right door.

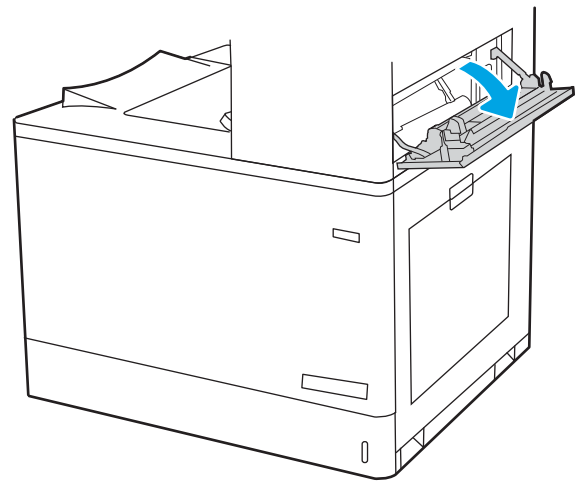

12. Gently pull out any jammed paper.

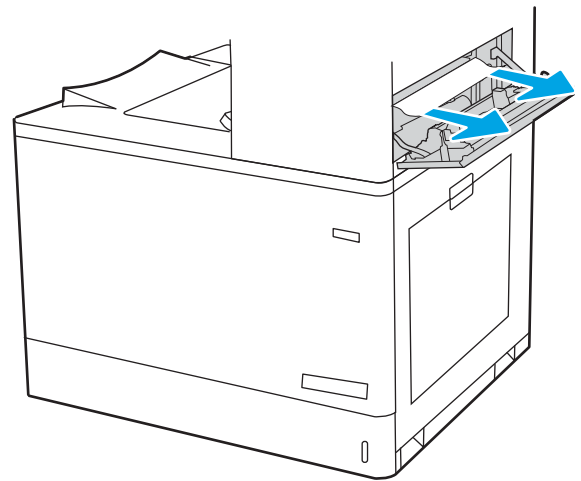

13. Close the upper-right door.

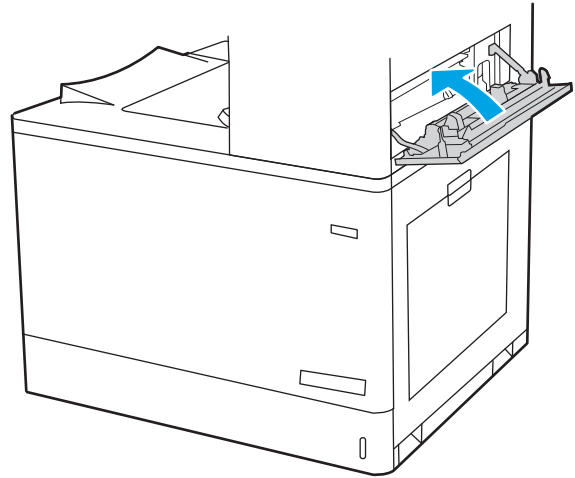

14. If paper is visible in the output bin, grasp the leading edge and gently remove it.

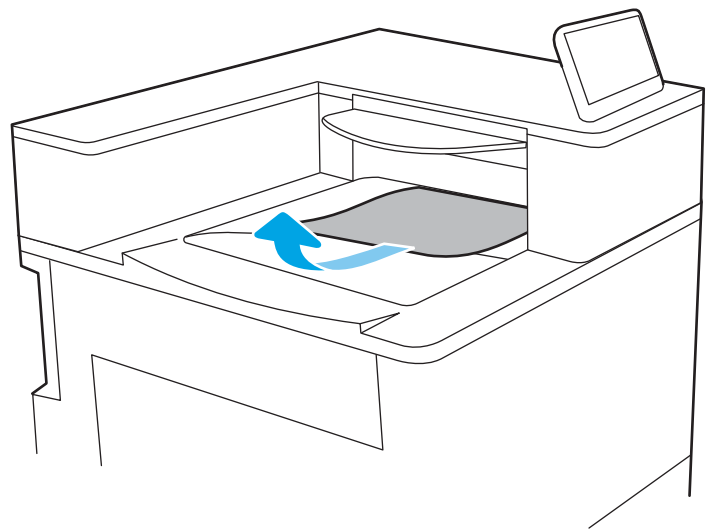

## Clear paper jams in Tray 2 (13.A2)

Use the following procedure to check for paper in all possible jam locations related to Tray 2 and inside the right door.

When a jam occurs, the control panel might display a message and an animation that assists in clearing the jam.

- 13.A2.XX Jam in tray 2

1. Open the tray and remove any jammed or damaged sheets of paper. Verify that the tray is not overfilled and that the paper guides are adjusted correctly.

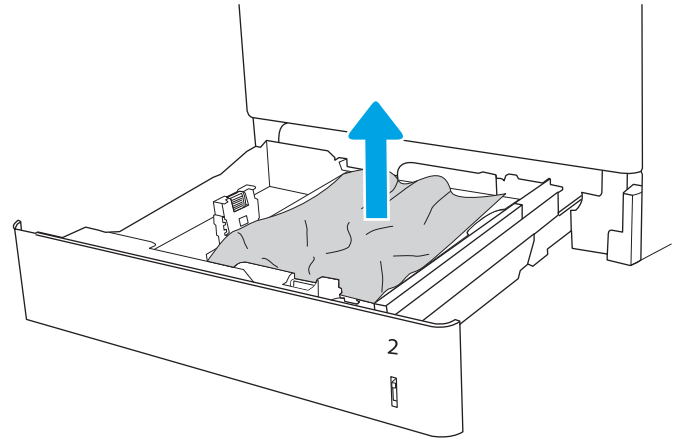

2. Pull the tray completely out of the printer by pulling and lifting it up slightly.

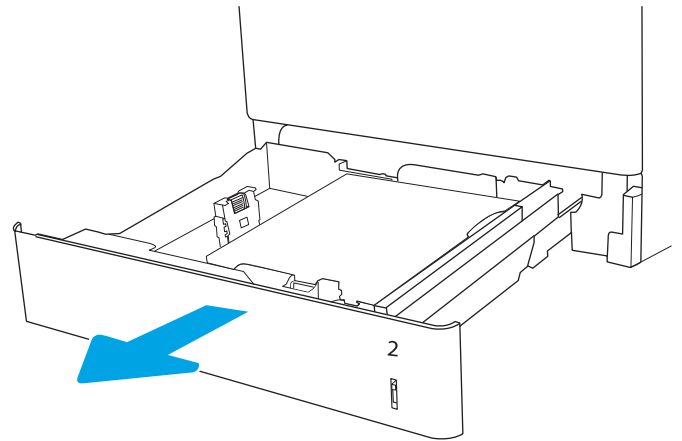

3. Gently remove any paper from the feed rollers inside the printer. First pull the paper to the left to release it, and then pull it forward to remove it.

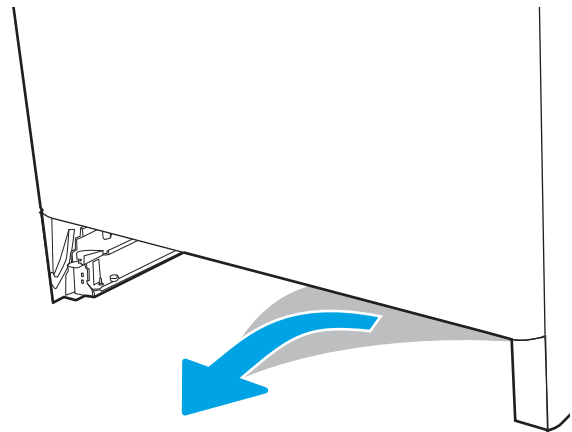

4. Install and close the tray.

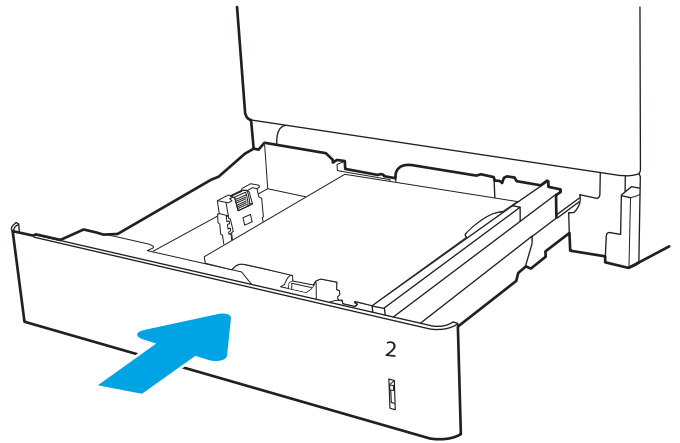

5. Open the right door.

**CAUTION:** Do not touch the transfer roller. Contaminants can affect print quality.

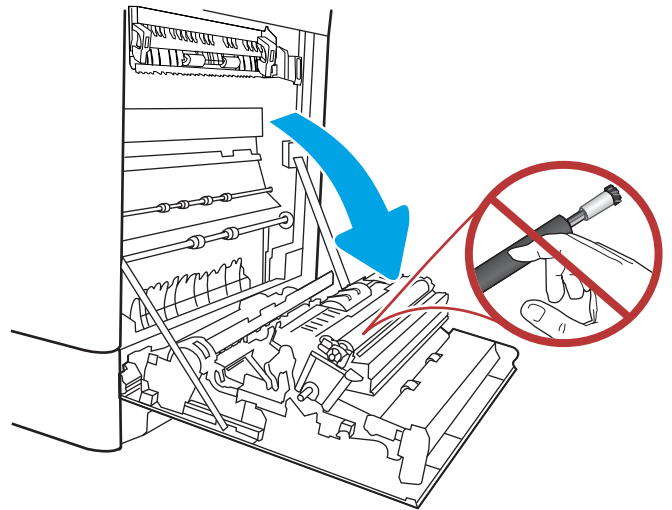

6. Gently pull out any jammed paper.

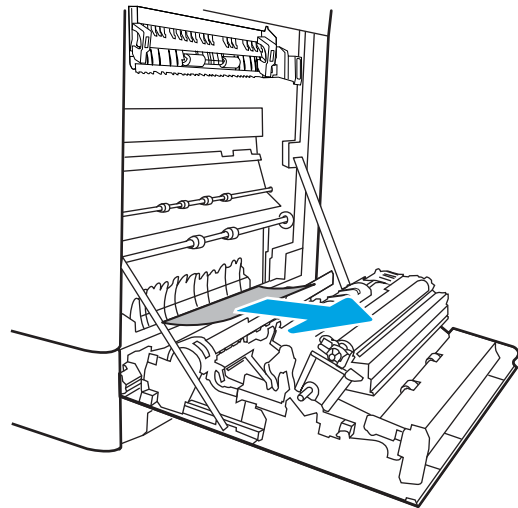

7. Gently pull out any jammed paper in the duplex area on the right door.

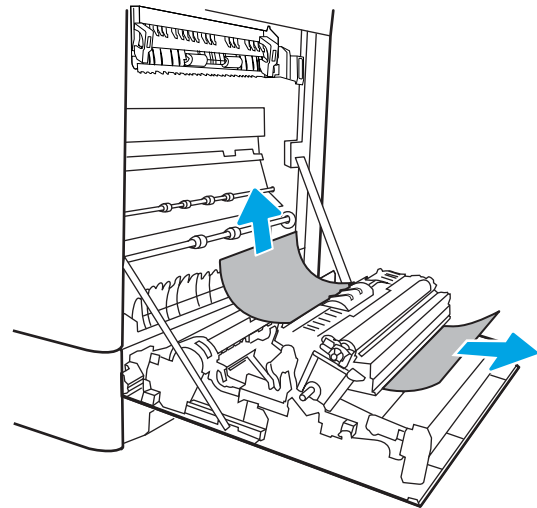

8. If paper is visible entering the bottom of the fuser, gently pull downward to remove it.

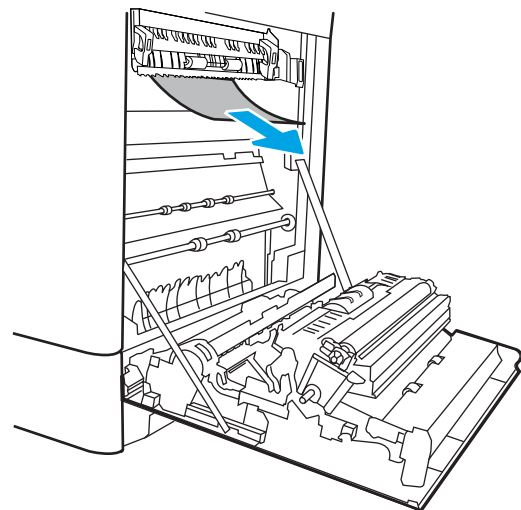

9. Paper could be jammed inside the fuser where it would not be visible. Grasp the fuser handles, squeeze the release levers, lift up slightly, and then pull straight out to remove the fuser.

**CAUTION:**  The fuser can be hot while the printer is in use. Wait for the fuser to cool before handling it.

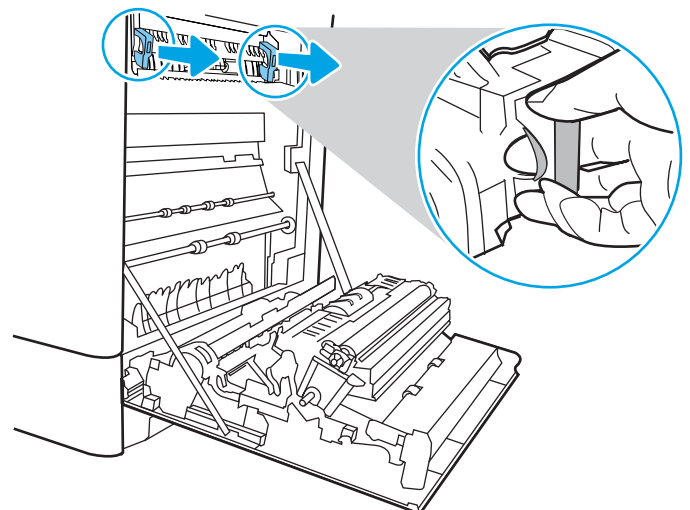

10. Open the jam-access door on the fuser. If paper is jammed inside the fuser, gently pull it straight up to remove it. If the paper tears, remove all paper fragments.

**NOTE:**  Even if the body of the fuser has cooled, the rollers that are inside could still be hot. Do not touch the fuser rollers.

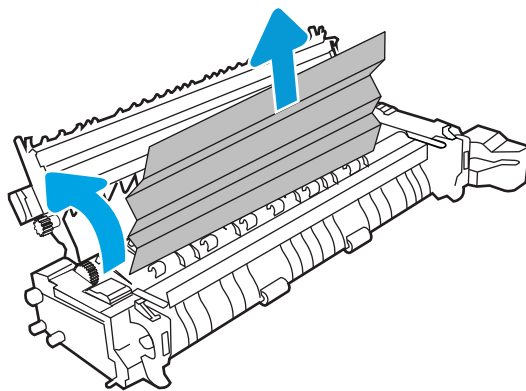

11. If paper is jammed as it enters the output bin, gently pull the paper out to remove it.

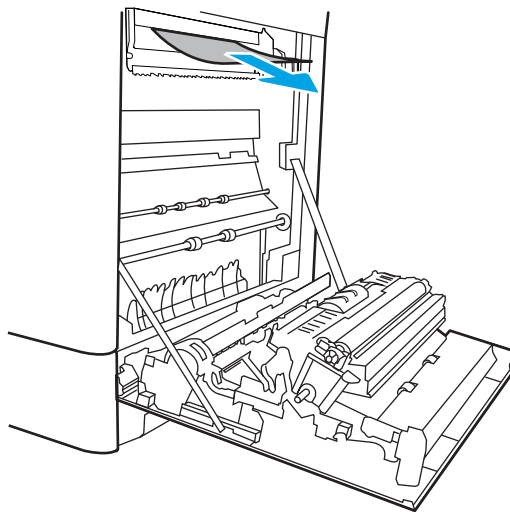

12. Close the jam-access door on the fuser, and push the fuser completely into the printer until it clicks into place.

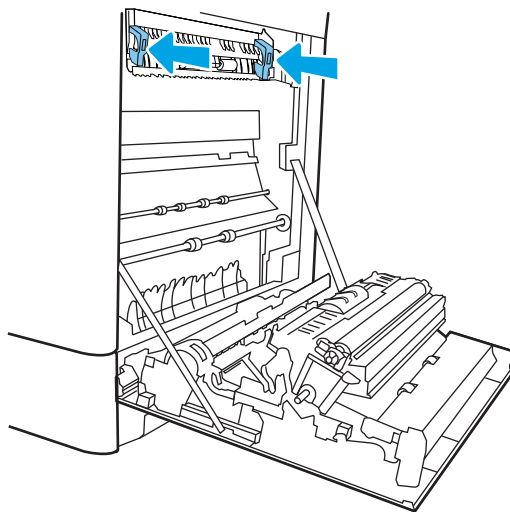



13. Close the right door.

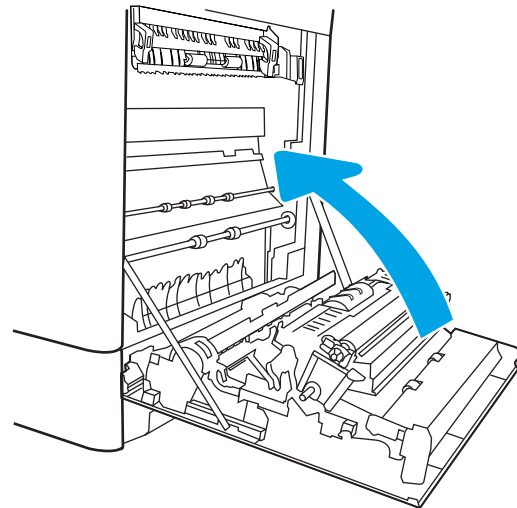

14. Open the upper-right door.

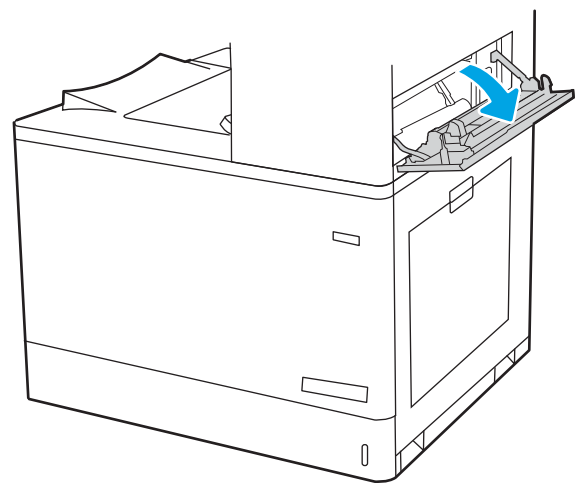

15. Gently pull out any jammed paper.

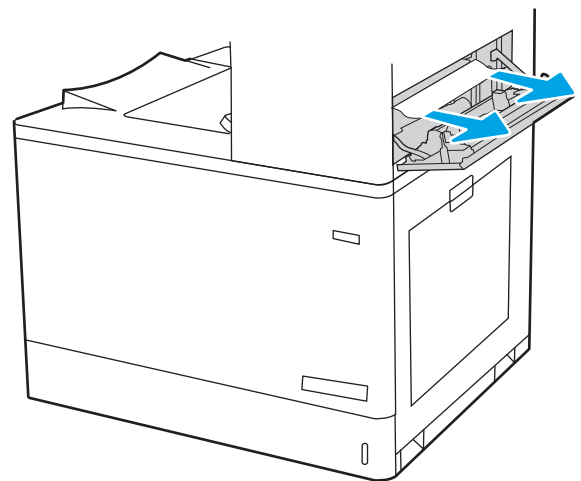

16. Close the upper-right door.

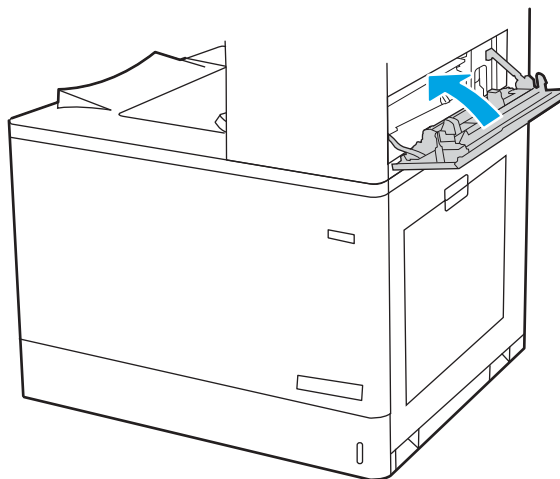

17. If paper is visible in the output bin, grasp the leading edge and gently remove it.

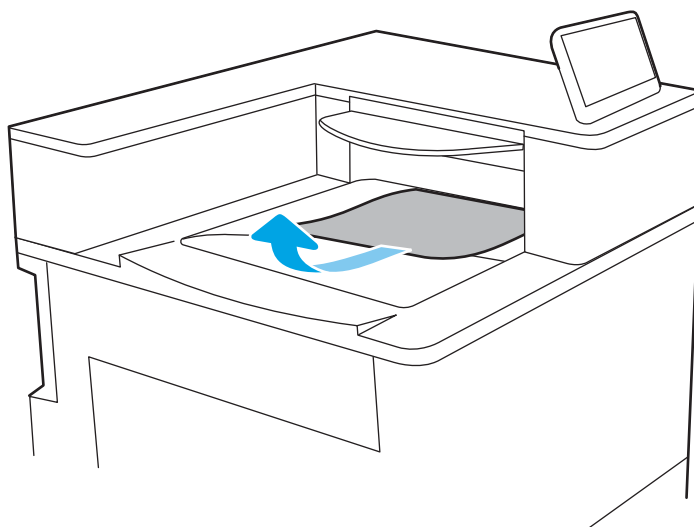

## Clear paper jams in the fuser (13.B9, 13.B2, 13.FF)

Use the following procedure to check for paper in all possible jam locations inside the right door.

When a jam occurs, the control panel might display a message and an animation that assists in clearing the jam.

- 13.B9.XX Jam in fuser
- 13.B2.XX Jam in <Cover or Door>.
- 13.FFEE Door Open Jam



**CAUTION:**



The fuser can be hot while the printer is in use. Wait for the fuser to cool before handling it.

1. Open the right door.

**CAUTION:** Do not touch the transfer roller. Contaminants can affect print quality.

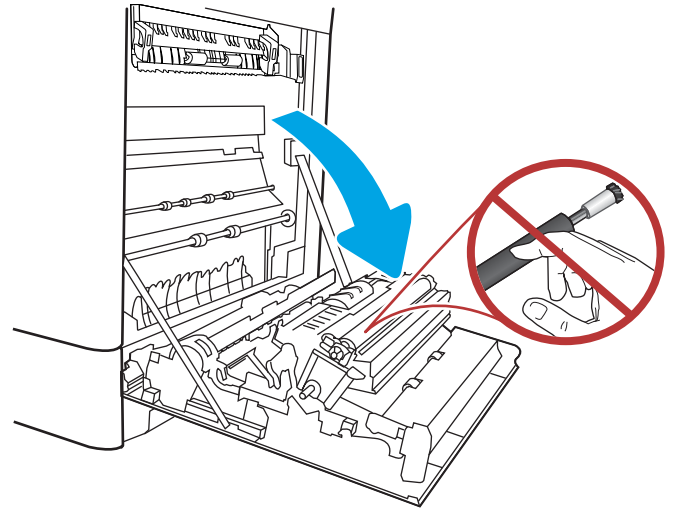

2. Gently pull out any jammed paper.

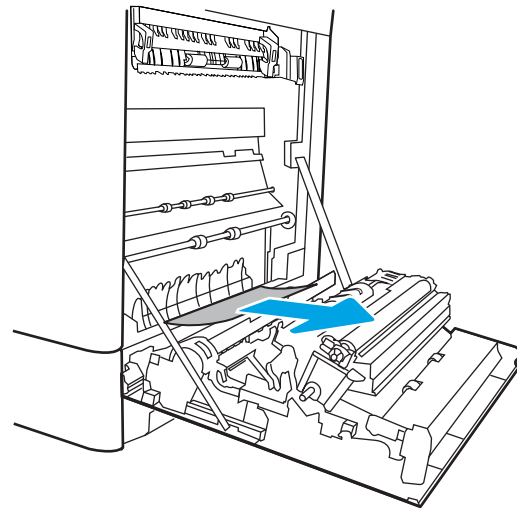

3. Gently pull out any jammed paper in the duplex area on the right door.

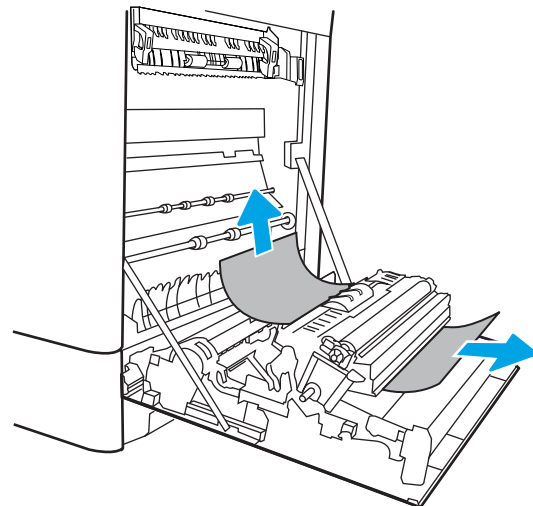

4. If paper is visible entering the bottom of the fuser, gently pull downward to remove it.

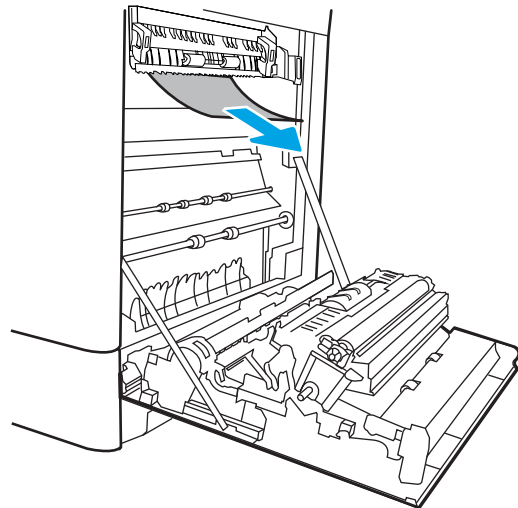

5. Paper could be jammed inside the fuser where it would not be visible. Grasp the fuser handles, squeeze the release levers, lift up slightly, and then pull straight out to remove the fuser.

**CAUTION:**  The fuser can be hot while the printer is in use. Wait for the fuser to cool before handling it.

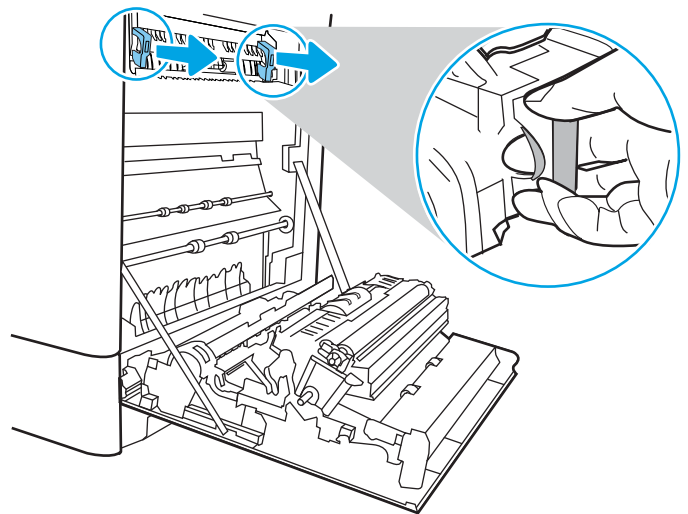

6. Open the jam-access door on the fuser. If paper is jammed inside the fuser, gently pull it straight up to remove it. If the paper tears, remove all paper fragments.

**CAUTION:**  Even if the body of the fuser has cooled, the rollers that are inside could still be hot. Do not touch the fuser rollers.

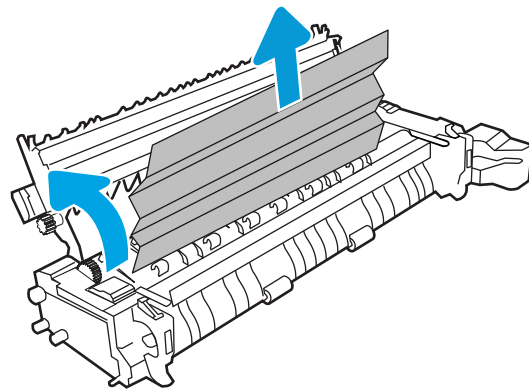

7. If paper is jammed as it enters the output bin, gently pull the paper out to remove it.

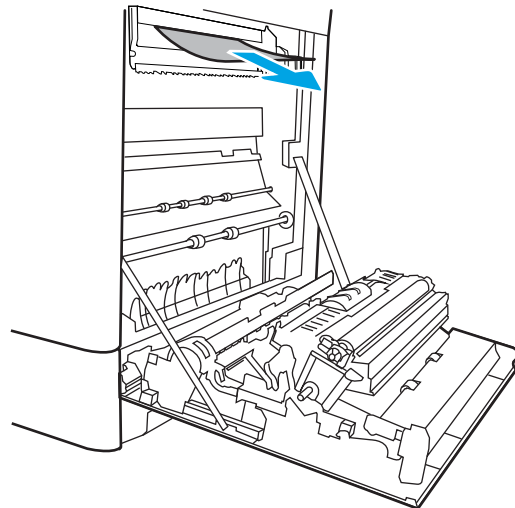

8. Close the jam-access door on the fuser, and push the fuser completely into the printer until it clicks into place.

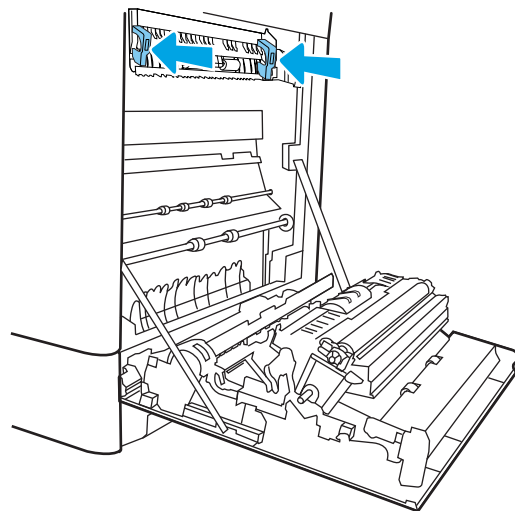

9. Close the right door.

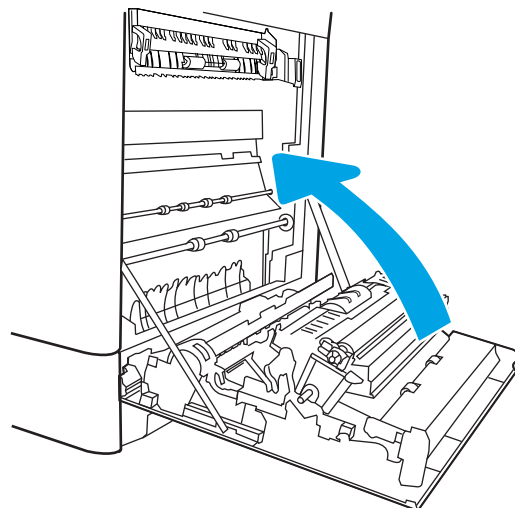

10. Open the upper-right door.

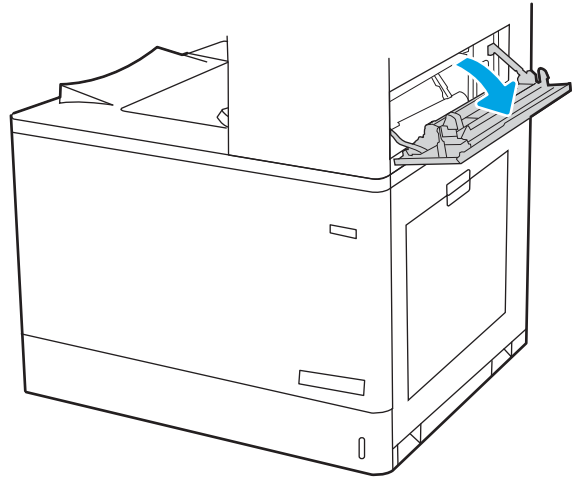

11. Gently pull out any jammed paper.

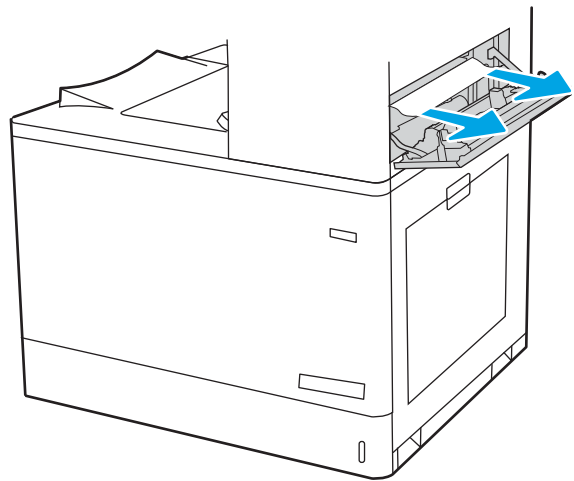

12. Close the upper-right door.

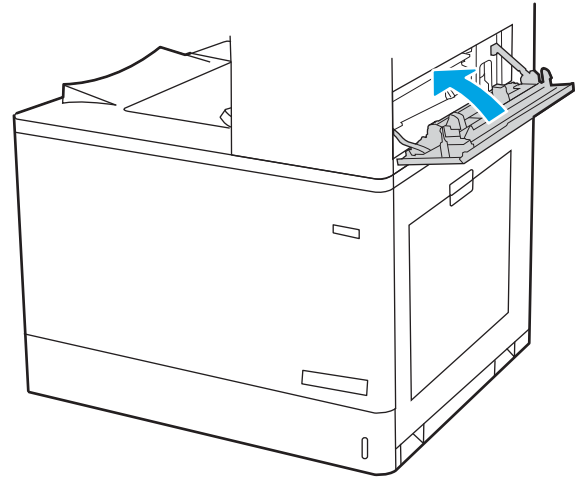

13. If paper is visible in the output bin, grasp the leading edge and gently remove it.

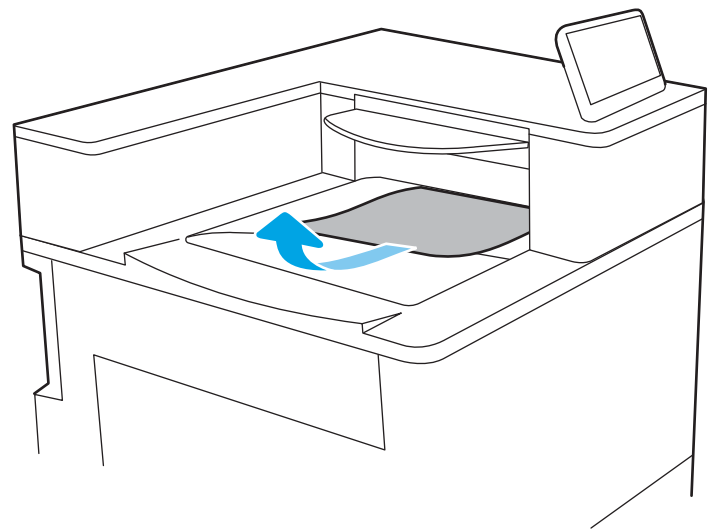

## Clear paper jams in the output bin (13.E1)

Use the following procedure to clear jams in the output bin.

When a jam occurs, the control panel might display a message and an animation that assists in clearing the jam.

- **13.E1.XX Jam at standard output bin**

1. If paper is visible in the output bin, grasp the leading edge and gently remove it.

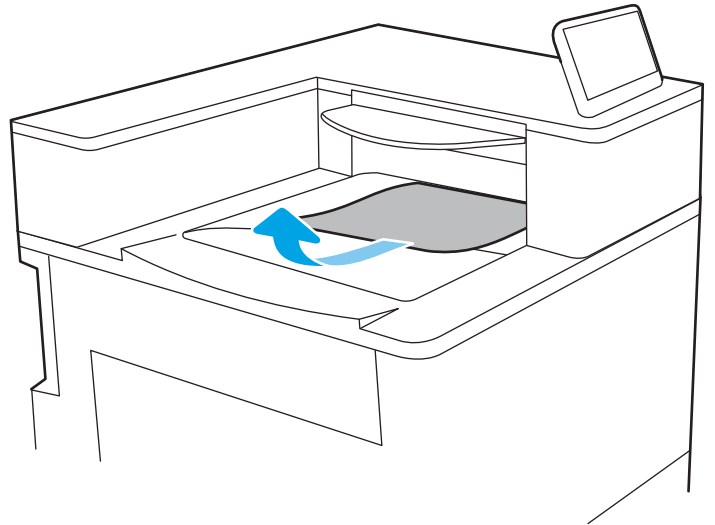

2. Open the upper-right door.

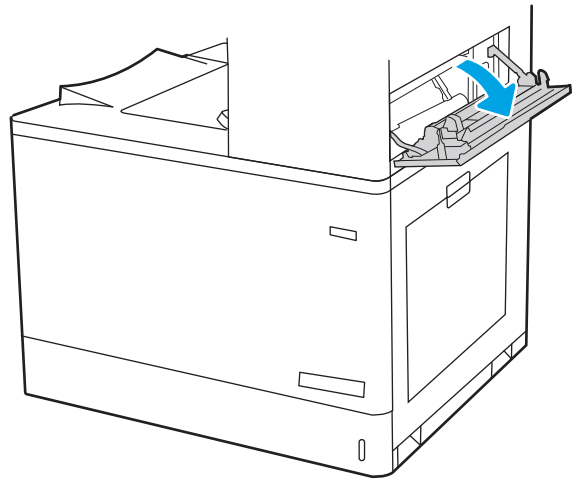



3. Gently pull out any jammed paper.

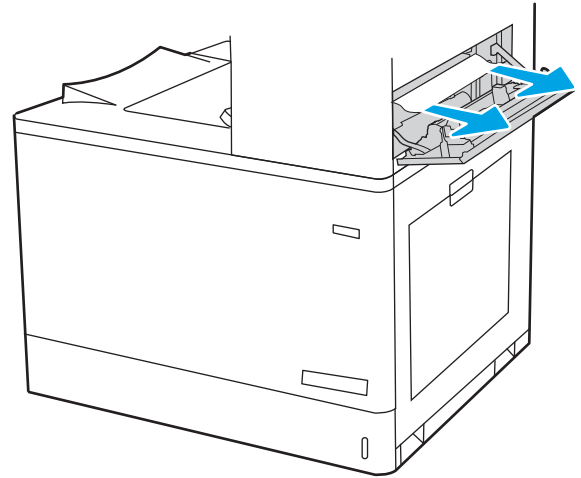

4. Close the upper-right door.

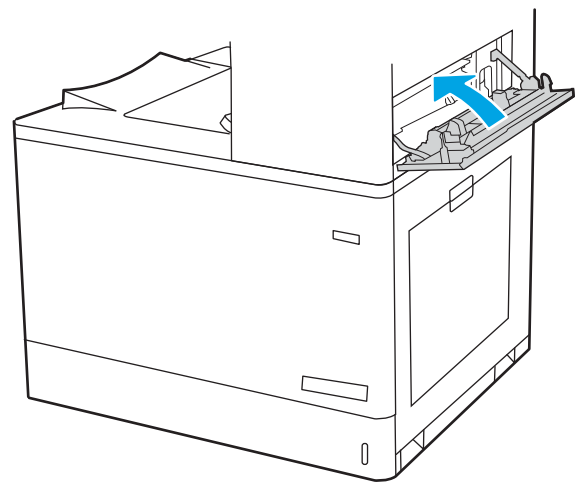

## Clear paper jams in the duplex area (13.D3)

Use the following procedure to check for paper in all possible jam locations inside the right door.

When a jam occurs, the control panel might display a message and an animation that assists in clearing the jam.

- 13.D3.XX Jam in duplex area

1. Open the right door.

**CAUTION:** Do not touch the transfer roller. Contaminants can affect print quality.

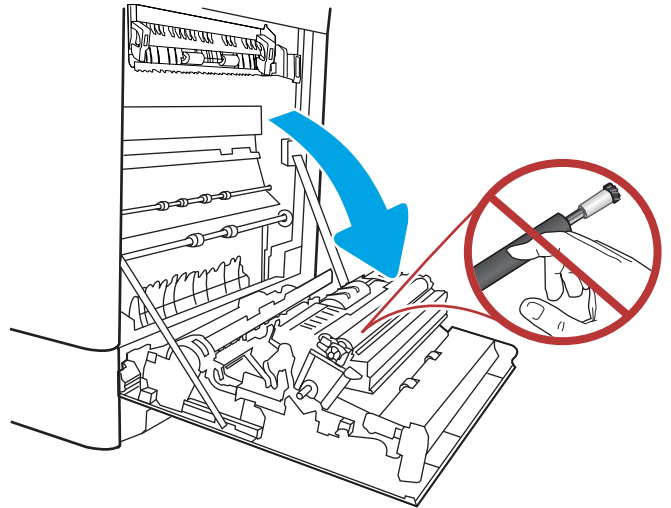

2. Gently pull out any jammed paper.

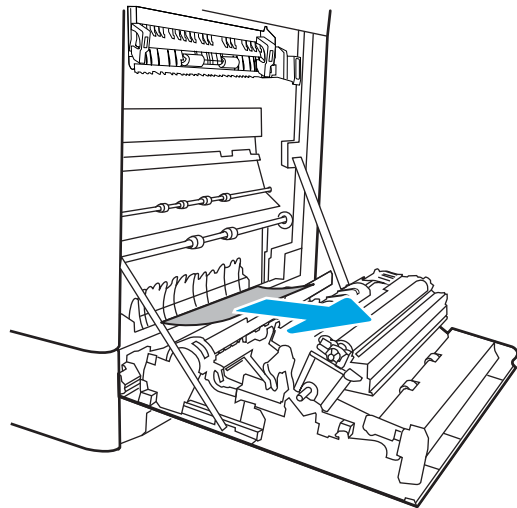

3. Gently pull out any jammed paper in the duplex area on the right door.

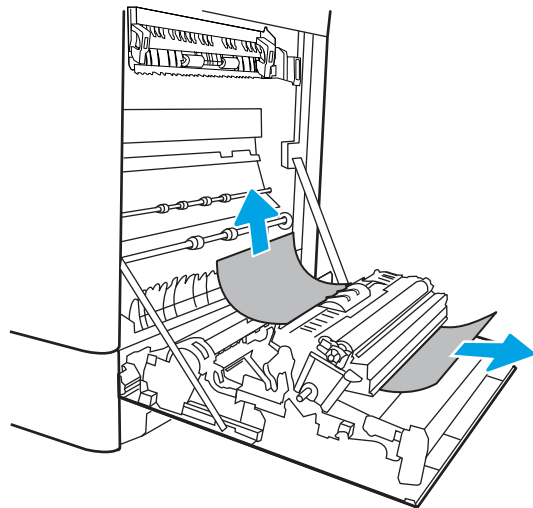

4. If paper is visible entering the bottom of the fuser, gently pull downward to remove it.

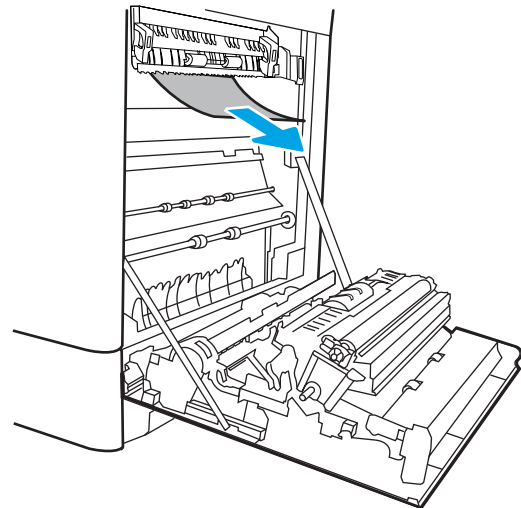

5. Paper could be jammed inside the fuser where it would not be visible. Grasp the fuser handles, squeeze the release levers, lift up slightly, and then pull straight out to remove the fuser.

**CAUTION:**  The fuser can be hot while the printer is in use. Wait for the fuser to cool before handling it.

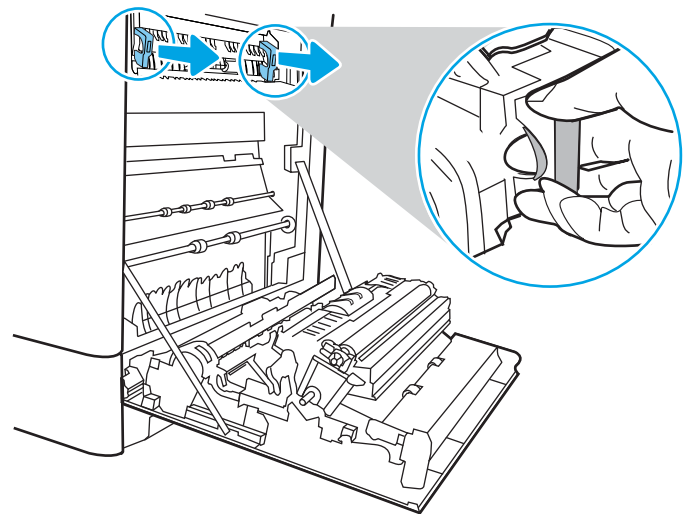

6. Open the jam-access door on the fuser. If paper is jammed inside the fuser, gently pull it straight up to remove it. If the paper tears, remove all paper fragments.

**CAUTION:**  Even if the body of the fuser has cooled, the rollers that are inside could still be hot. Do not touch the fuser rollers.

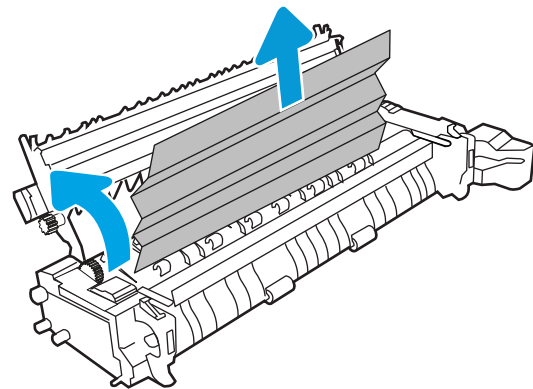

7. If paper is jammed as it enters the output bin, gently pull the paper out to remove it.

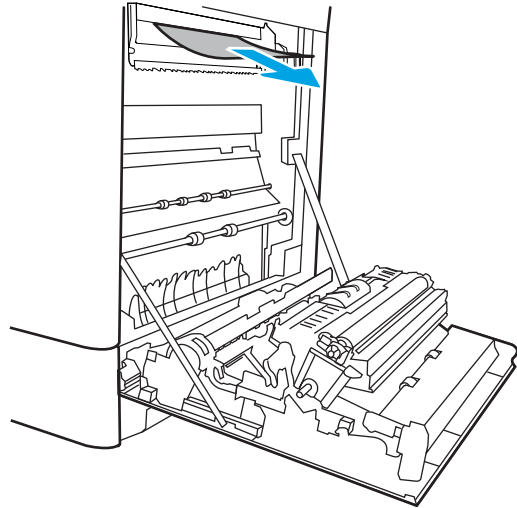

8. Close the jam-access door on the fuser, and push the fuser completely into the printer until it clicks into place.

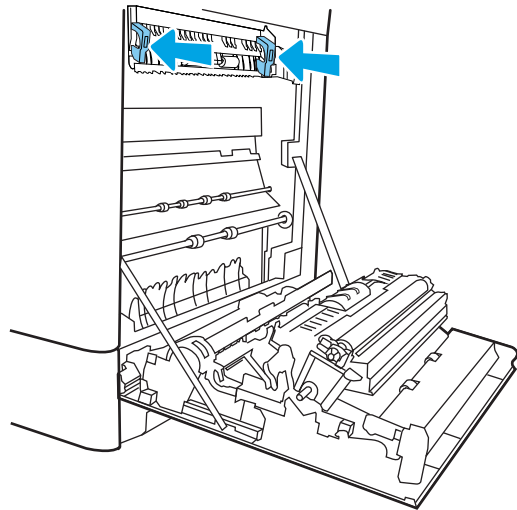

9. Close the right door.

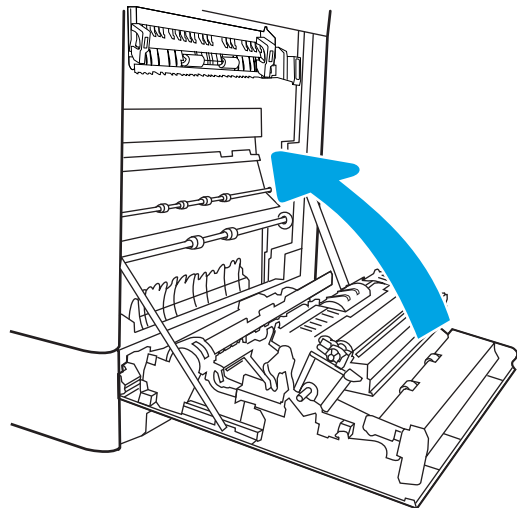

10. Open the upper-right door.

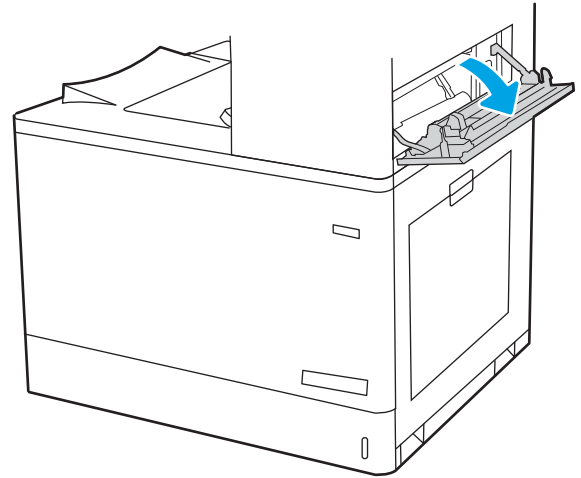

11. Gently pull out any jammed paper.

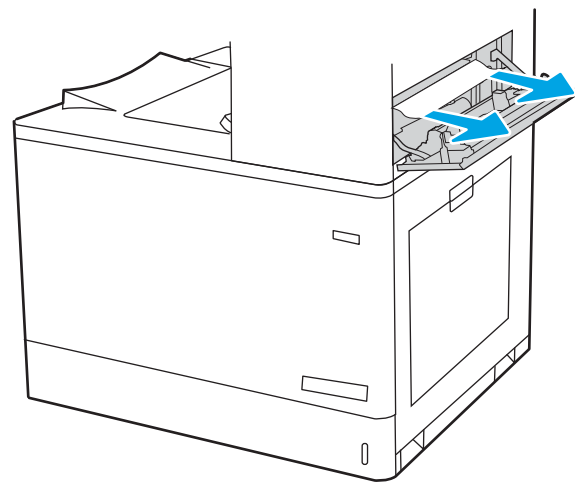

12. Close the upper-right door.

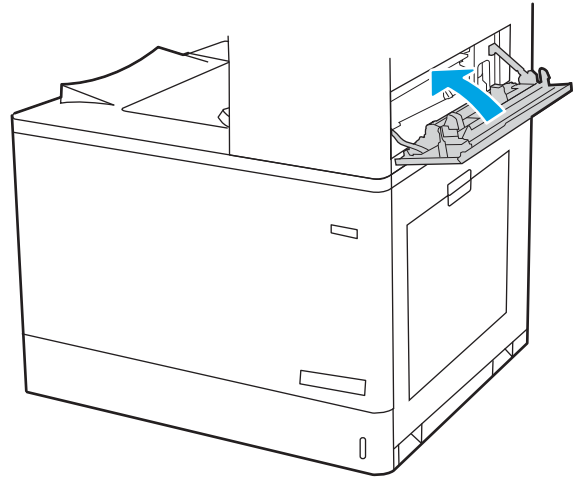

13. If paper is visible in the output bin, grasp the leading edge and gently remove it.

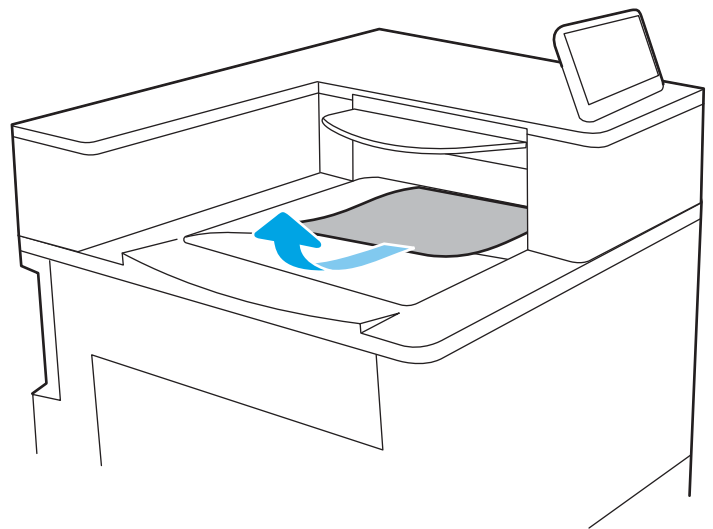

## Clear paper jams in the 550-sheet trays (13.A3, 13.A4)

Use the following procedure to check for paper in all possible jam locations related to the 550-sheet trays and inside the right door.

When a jam occurs, the control panel might display a message and an animation that assists in clearing the jam.

- 13.A3.XX Jam in tray 3
- 13.A4.XX Jam in tray 4

1. Open the tray and remove any jammed or damaged sheets of paper. Verify that the tray is not overfilled and that the paper guides are adjusted correctly.

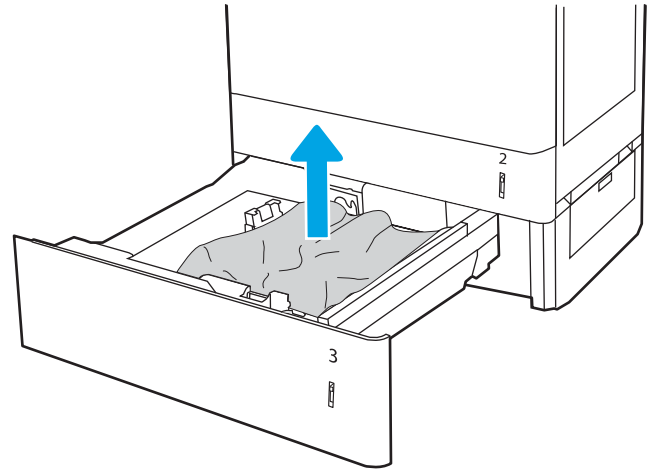

2. Release two tabs at the back of the tray, and then pull the tray completely out of the printer.

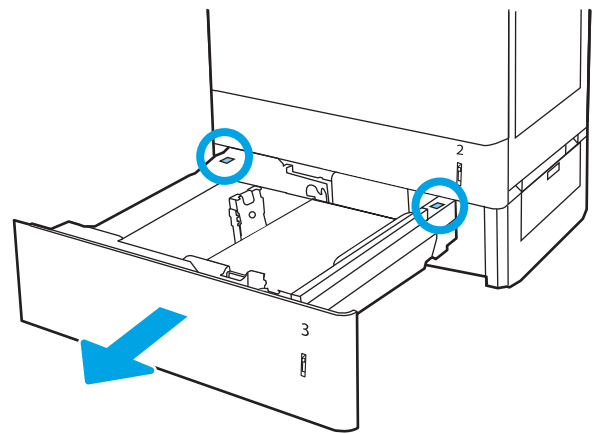

3. Remove any paper from the feed rollers inside the printer. First pull the paper to the left to release it, and then pull it forward to remove it.

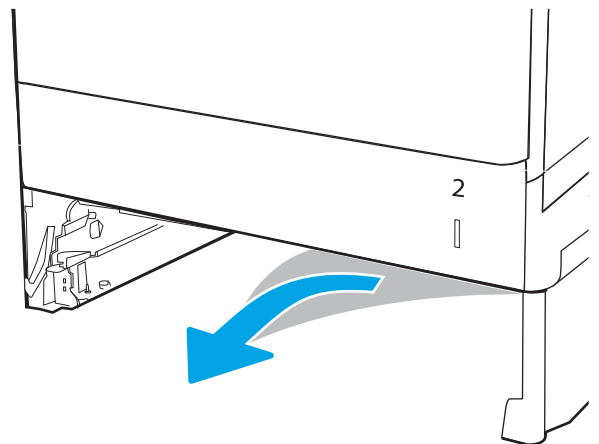

- 4. Install and close the tray.

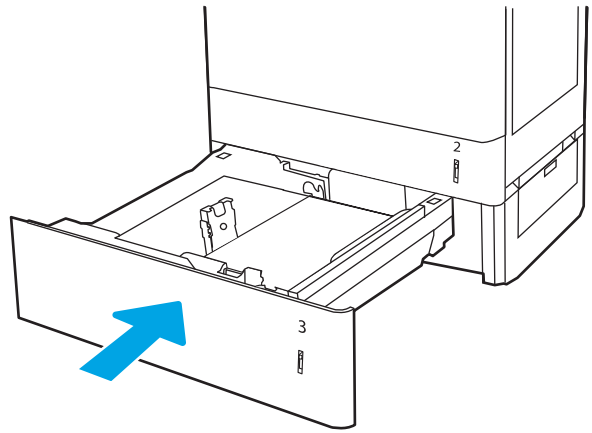

- 5. Open the lower-right door.

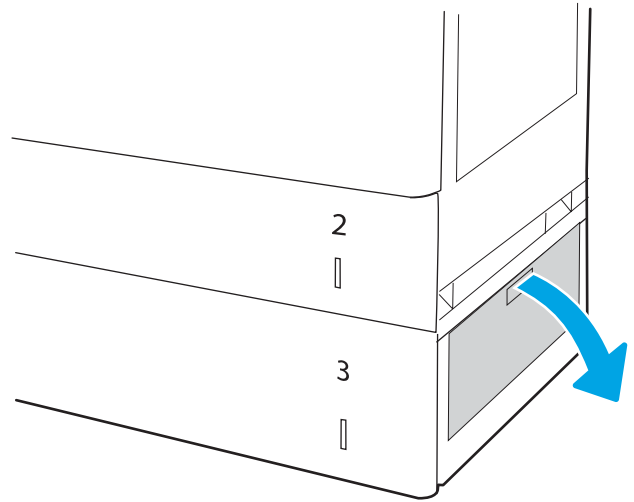

- 6. Gently pull out any jammed paper.

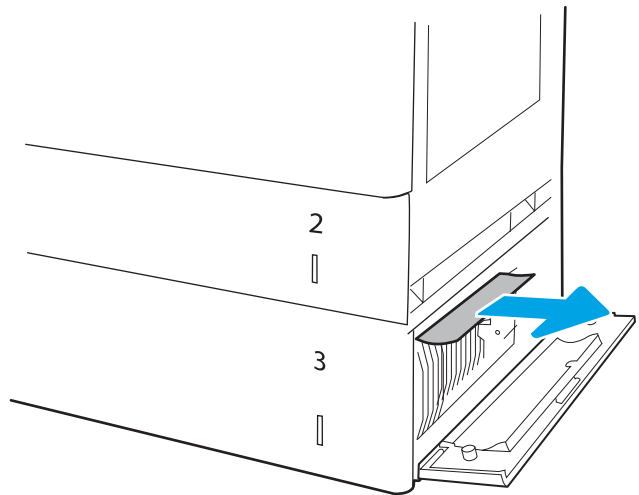



7. Close the lower-right door.

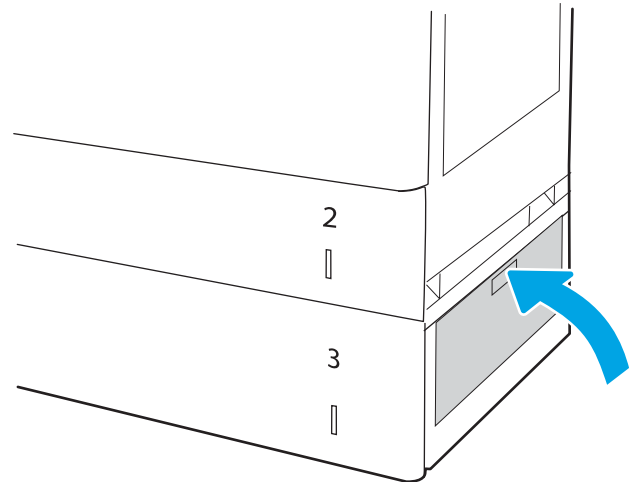

8. Open the right door.

**CAUTION:** Do not touch the transfer roller. Contaminants can affect print quality.

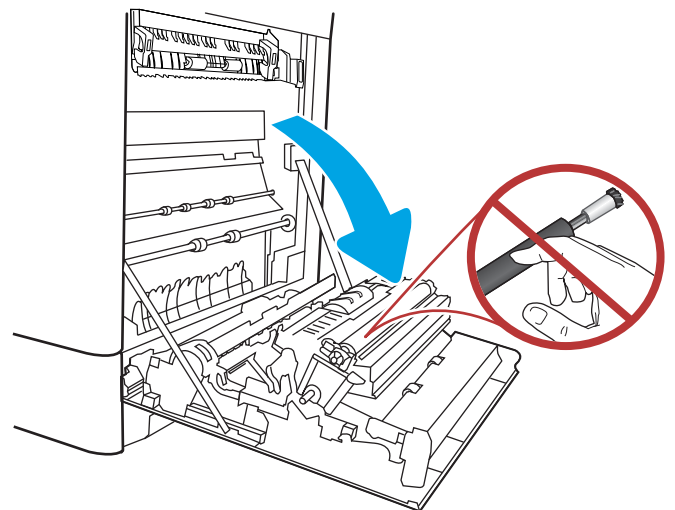

9. Gently pull out any jammed paper.

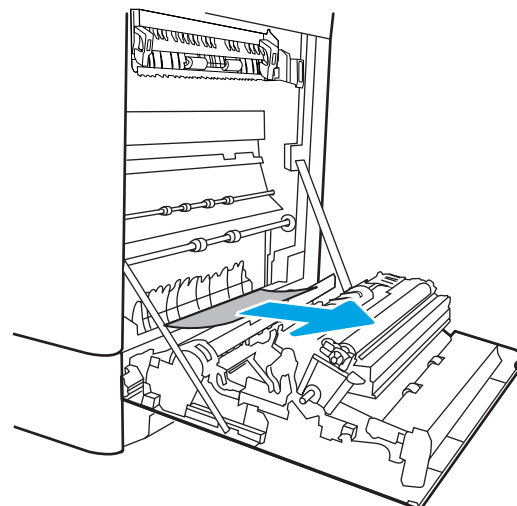

10. Gently pull out any jammed paper in the duplex area on the right door.

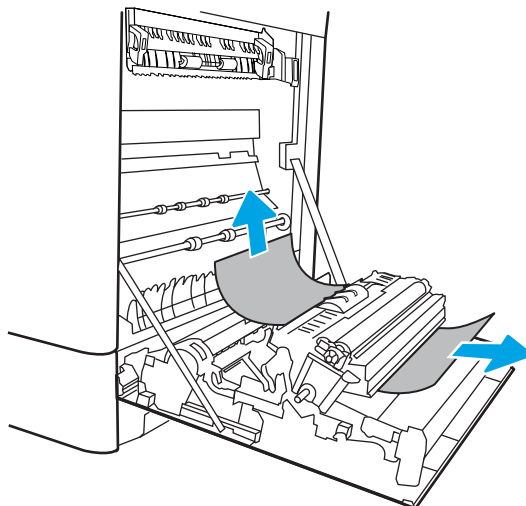

11. If paper is visible entering the bottom of the fuser, gently pull downward to remove it.

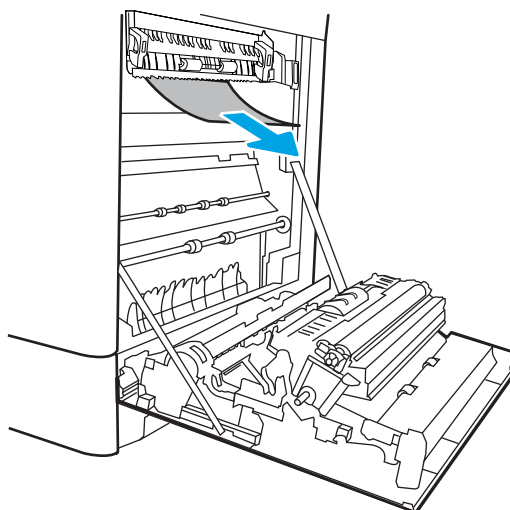

12. Paper could be jammed inside the fuser where it would not be visible. Grasp the fuser handles, squeeze the release levers, lift up slightly, and then pull straight out to remove the fuser.

**CAUTION:**  The fuser can be hot while the printer is in use. Wait for the fuser to cool before handling it.

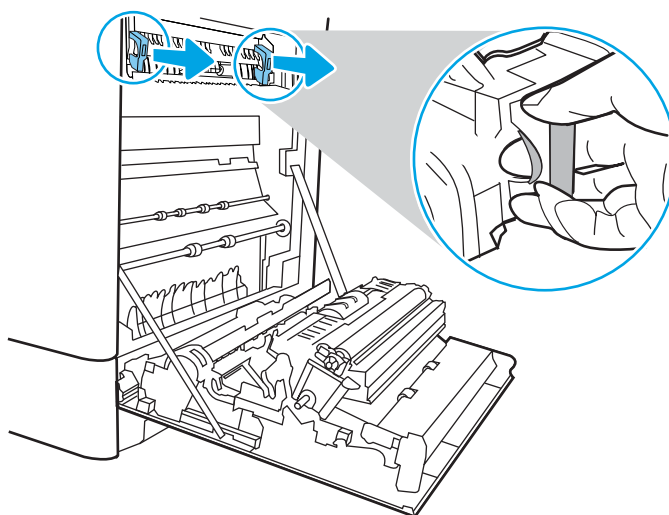

13. Open the jam-access door on the fuser. If paper is jammed inside the fuser, gently pull it straight up to remove it. If the paper tears, remove all paper fragments.

**NOTE:**  Even if the body of the fuser has cooled, the rollers that are inside could still be hot. Do not touch the fuser rollers.

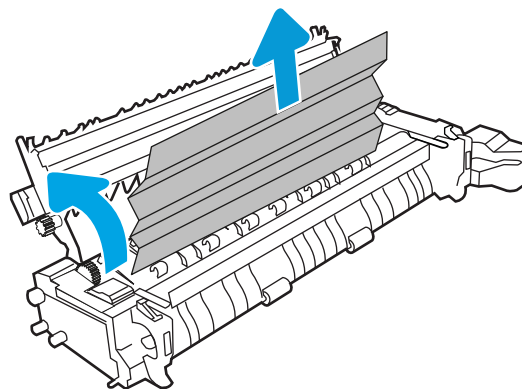

14. If paper is jammed as it enters the output bin, gently pull the paper out to remove it.

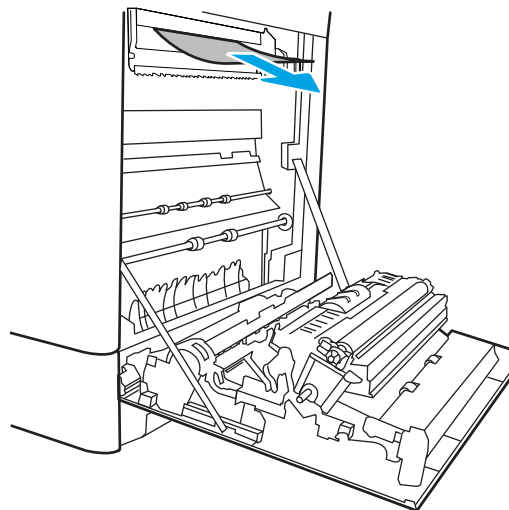

15. Close the jam-access door on the fuser, and push the fuser completely into the printer until it clicks into place.

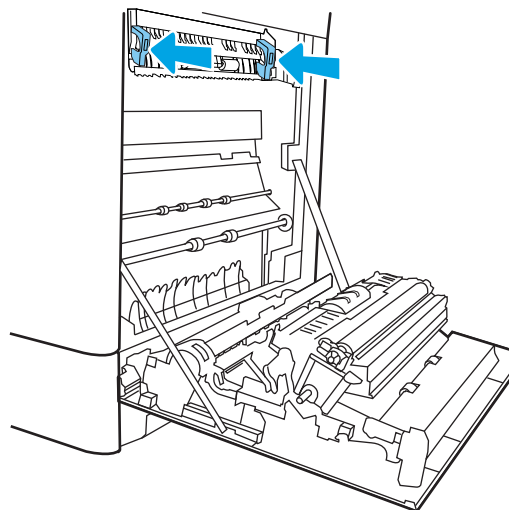

16. Close the right door.

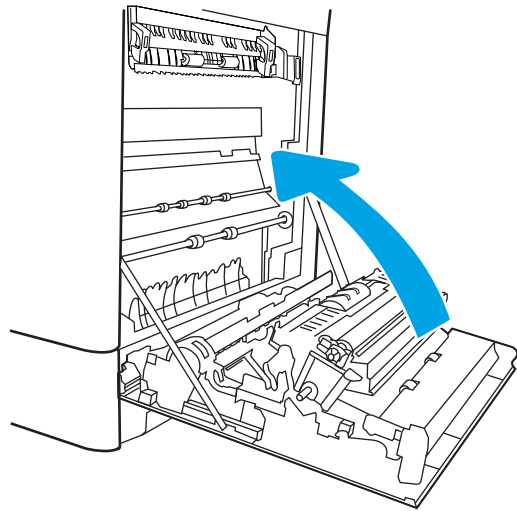

17. Open the upper-right door.

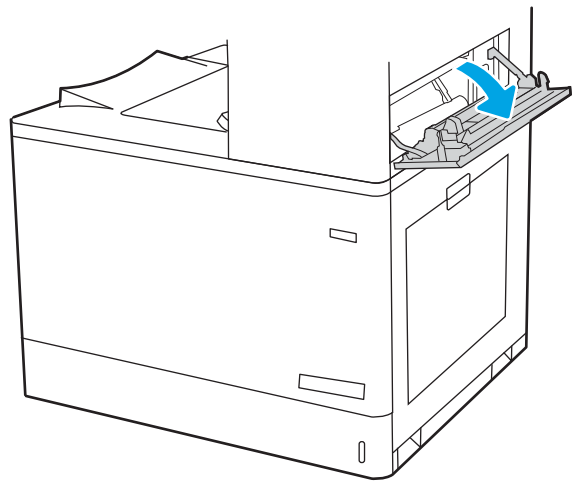

18. Gently pull out any jammed paper.

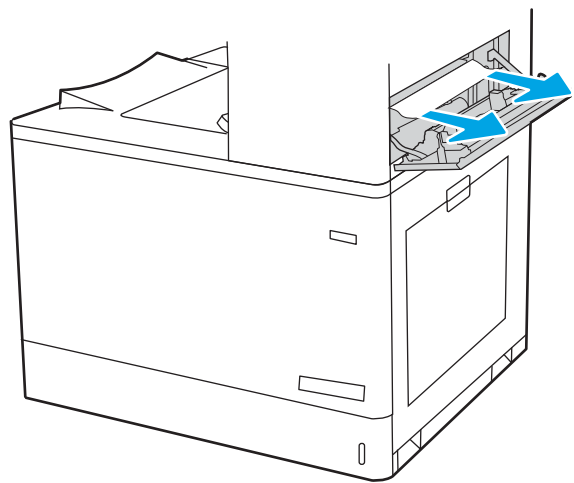

19. Close the upper-right door.

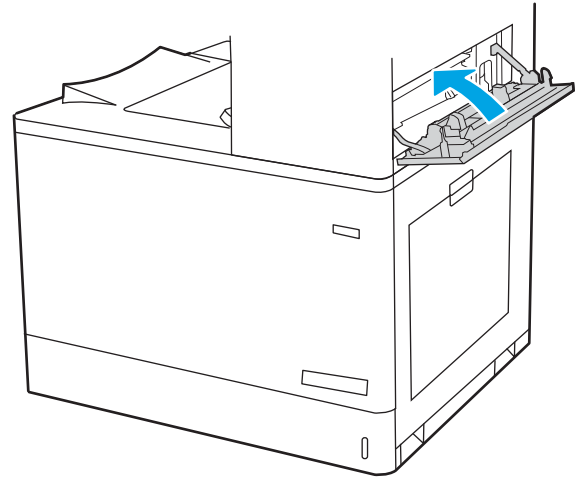

20. If paper is visible in the output bin, grasp the leading edge and gently remove it.

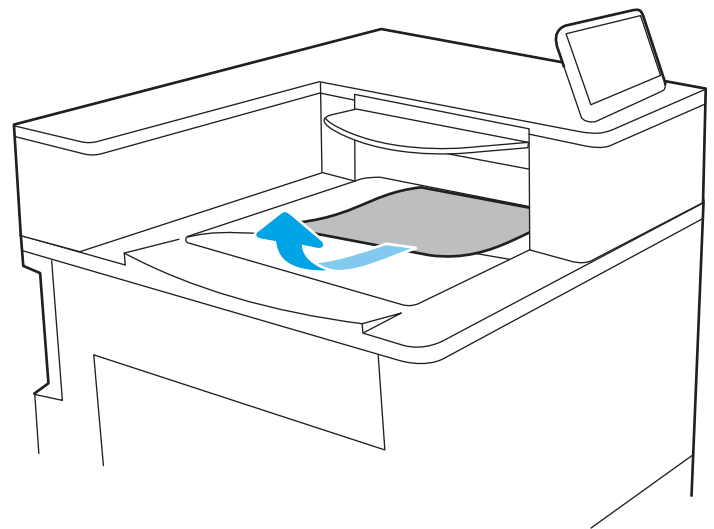

## Clear paper jams in the 2 x 550 paper trays (13.A4, 13.A5)

Use the following procedure to check for paper in all possible jam locations related to the 2 x 550-sheet trays and inside the right door.

When a jam occurs, the control panel might display a message and an animation that assists in clearing the jam.

- 13.A4.XX Jam in tray 4
- 13.A5.XX Jam in tray 5

1. Open the tray and remove any jammed or damaged sheets of paper. Verify that the tray is not overfilled and that the paper guides are adjusted correctly.

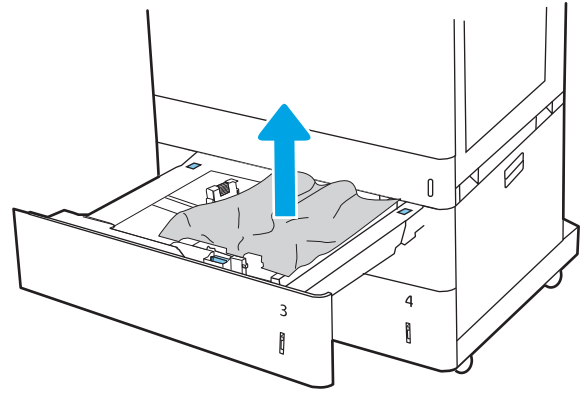

2. Release two tabs at the back of the tray, and then pull the tray completely out of the printer.

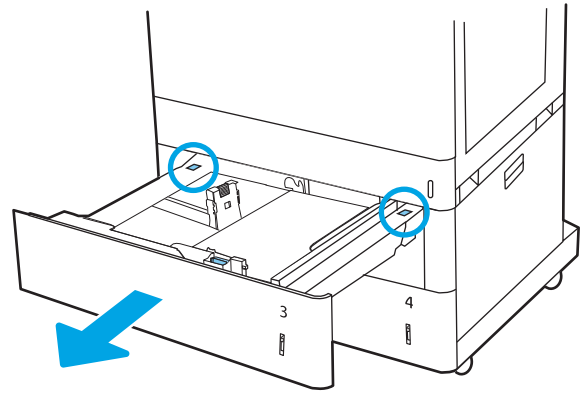

3. Remove the jammed paper from the feed rollers inside the printer. First pull the paper to the left, and then pull it forward to remove it.

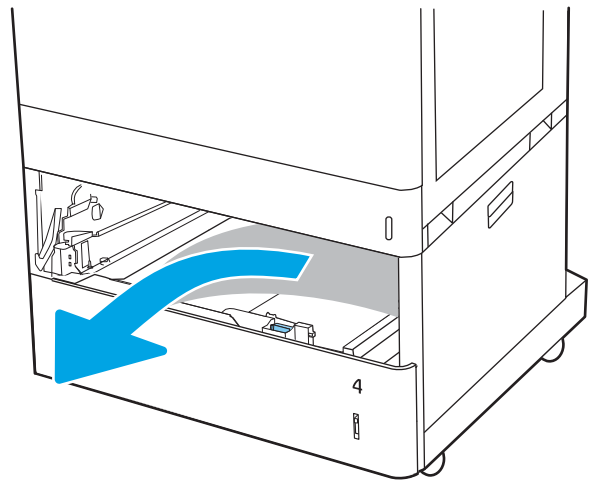

4. Open the lower-right door.

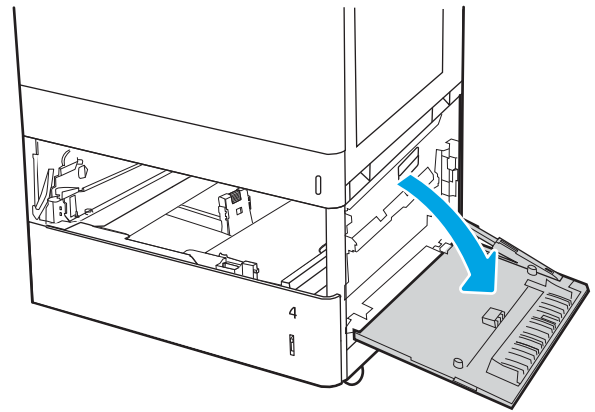

5. Gently pull out any jammed paper.

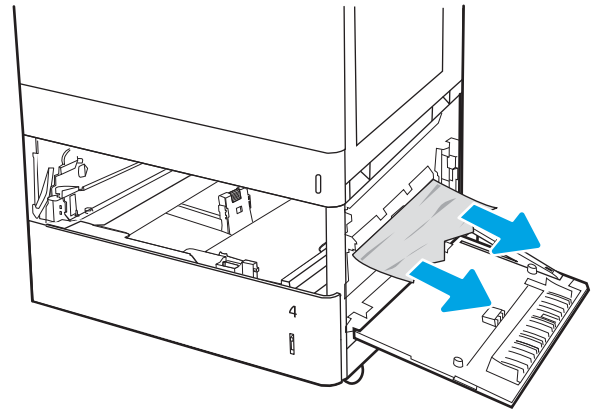

6. Close the lower-right door, and then install and close the tray.

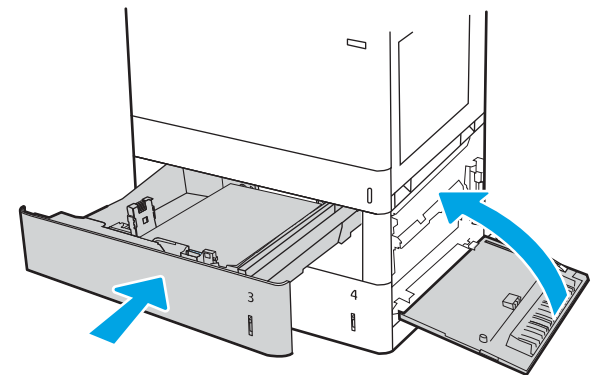

7. Open the right door.

**CAUTION:** Do not touch the transfer roller. Contaminants can affect print quality.

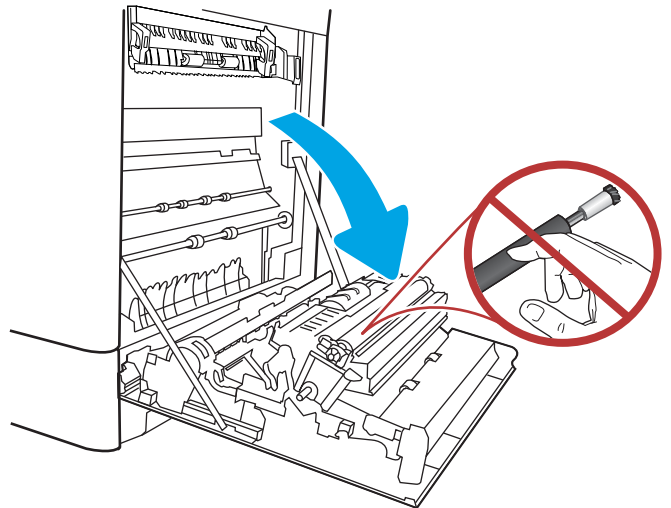

8. Gently pull out any jammed paper.

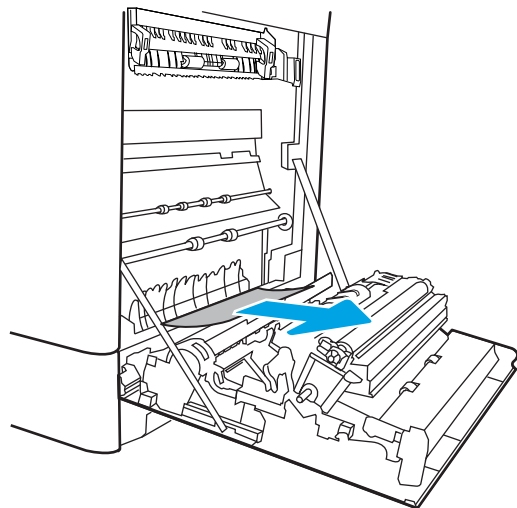

9. Gently pull out any jammed paper in the duplex area on the right door.

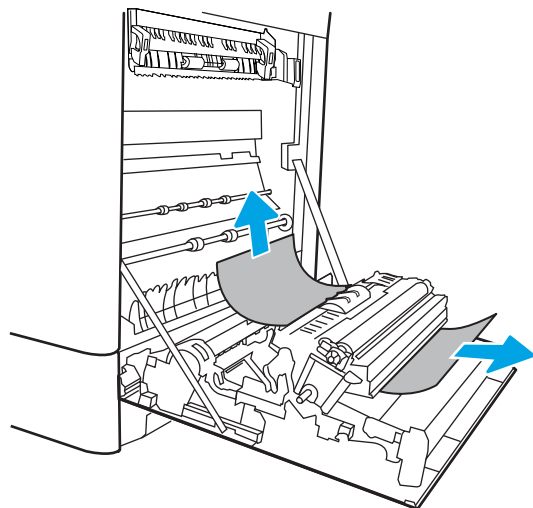



10. If paper is visible entering the bottom of the fuser, gently pull downward to remove it.

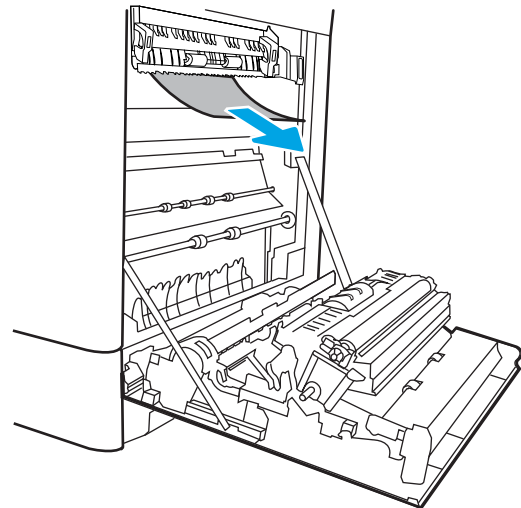

11. Paper could be jammed inside the fuser where it would not be visible. Grasp the fuser handles, squeeze the release levers, lift up slightly, and then pull straight out to remove the fuser.

**CAUTION:**  The fuser can be hot while the printer is in use. Wait for the fuser to cool before handling it.

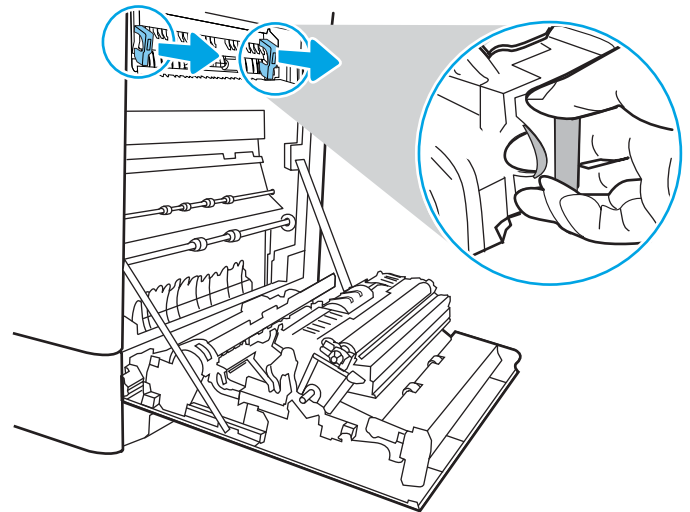

12. Open the jam-access door on the fuser. If paper is jammed inside the fuser, gently pull it straight up to remove it. If the paper tears, remove all paper fragments.

**CAUTION:**  Even if the body of the fuser has cooled, the rollers that are inside could still be hot. Do not touch the fuser rollers.

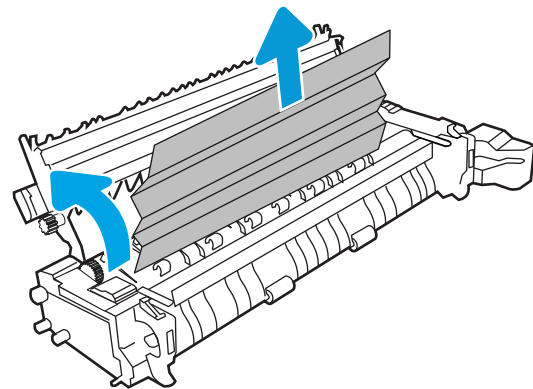

13. If paper is jammed as it enters the output bin, gently pull the paper out to remove it.

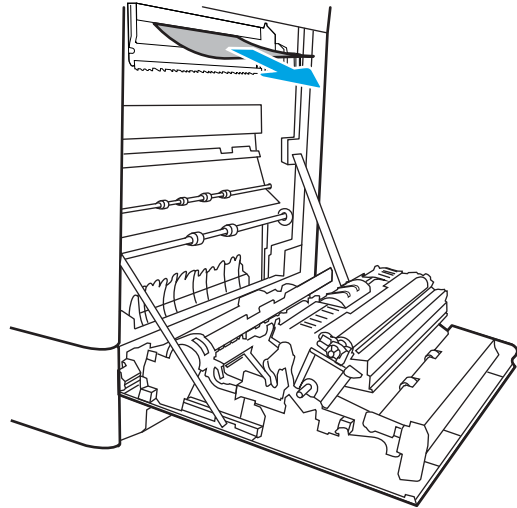

14. Close the jam-access door on the fuser, and push the fuser completely into the printer until it clicks into place.

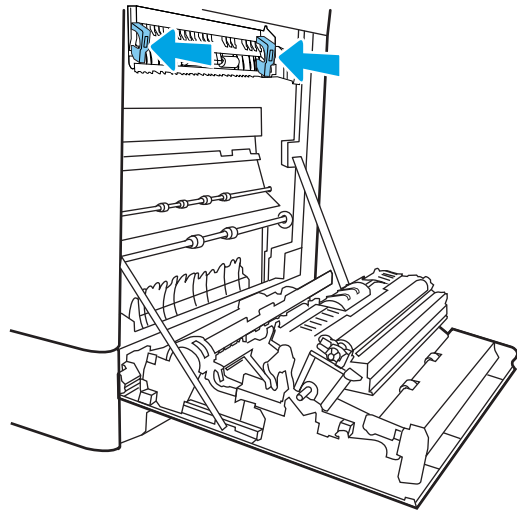

15. Close the right door.

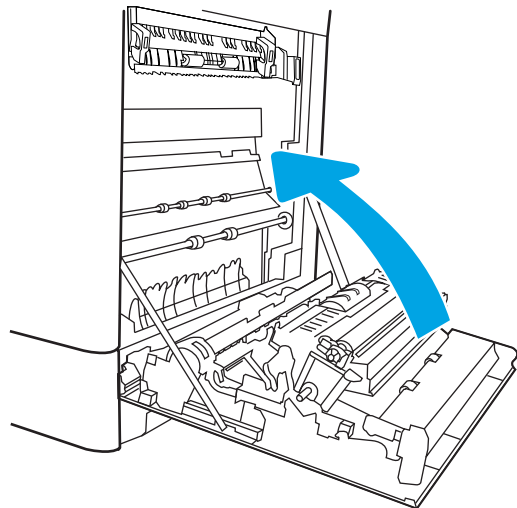

16. Open the upper-right door.

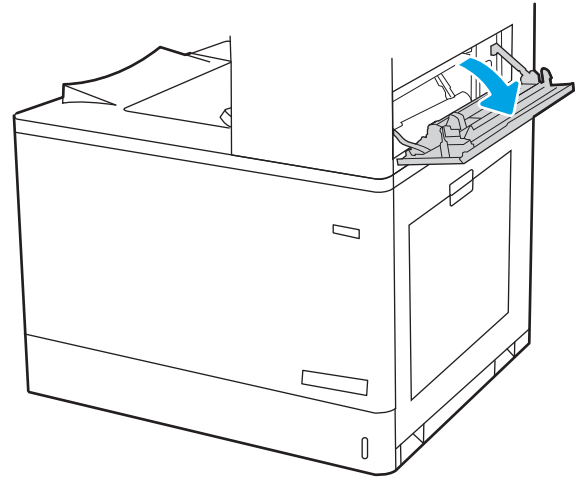

17. Gently pull out any jammed paper.

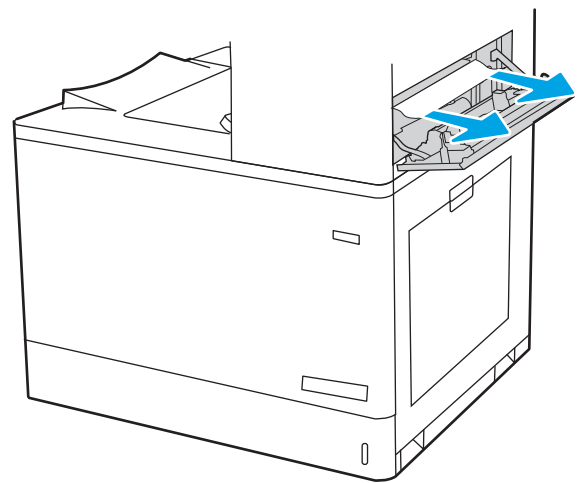

18. Close the upper-right door.

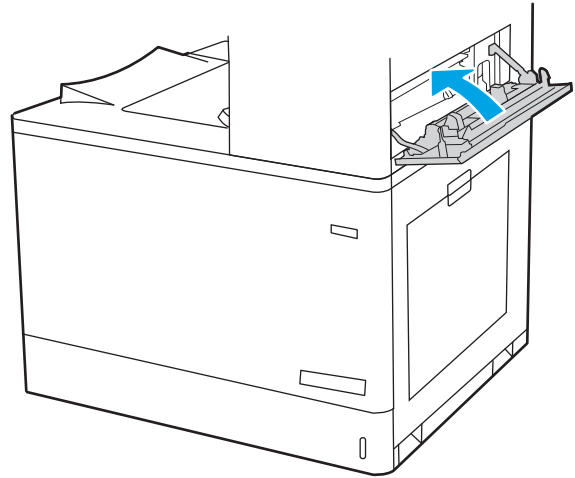

19. If paper is visible in the output bin, grasp the leading edge and gently remove it.

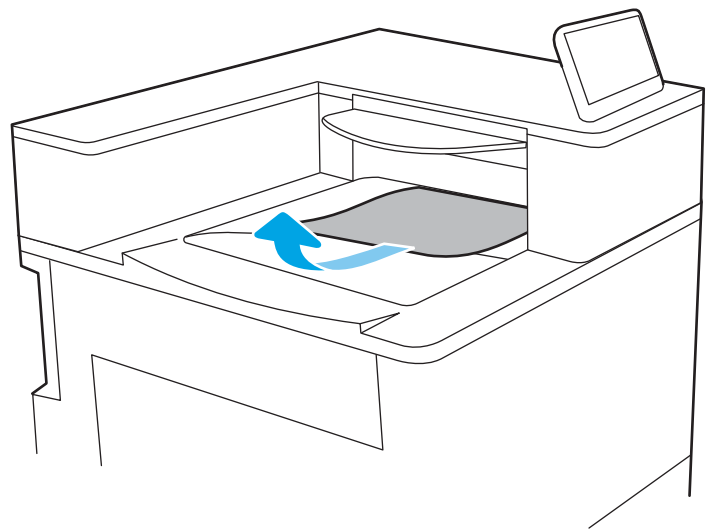

### Clear paper jams in the 2,700-sheet high-capacity input paper trays (13.A3, 13.A4, 13.A5, 13.A7)

Use the following procedure to check for paper in all possible jam locations related to the 2,700-sheet high-capacity input (HCI) paper tray and inside the right door.

When a jam occurs, the control panel might display a message and an animation that assists in clearing the jam.

1. Release the tray latch on the left HCl tray. Slide the tray away from the printer until it stops, and then lift it up and away from the printer to remove it.

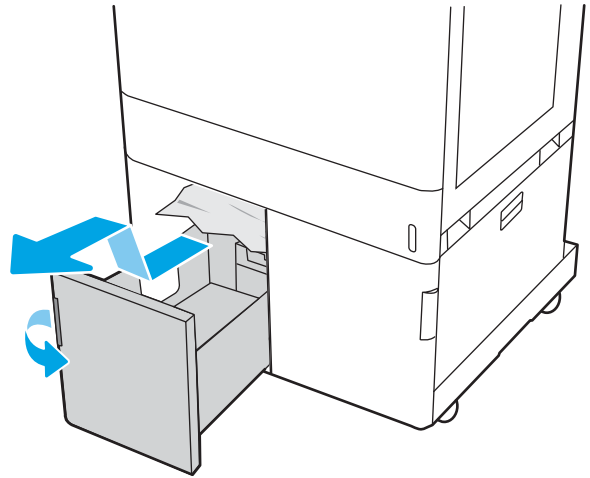

2. Remove any jammed paper from the feed rollers inside the printer. First pull the paper to the left, and then pull it forward to remove it.

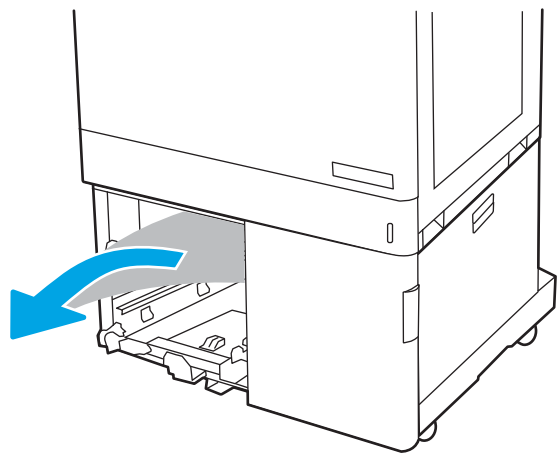

3. Install and close the left HCl tray.

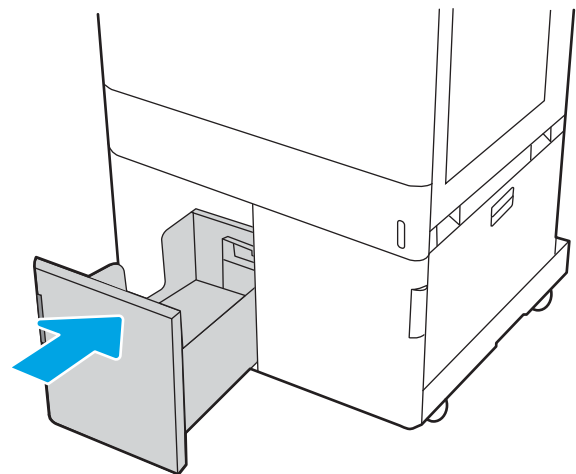

4. Release the tray latch on the right HCl tray. Slide the tray away from the printer until it stops, and then lift it up and away from the printer to remove it.

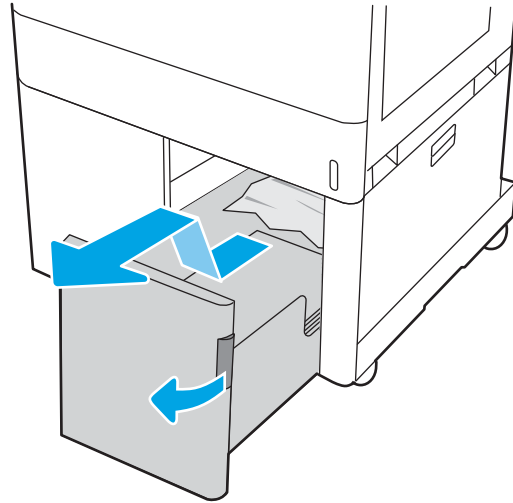

5. Remove any jammed paper from the feed rollers inside the printer. First pull the paper to the left, and then pull it forward to remove it.

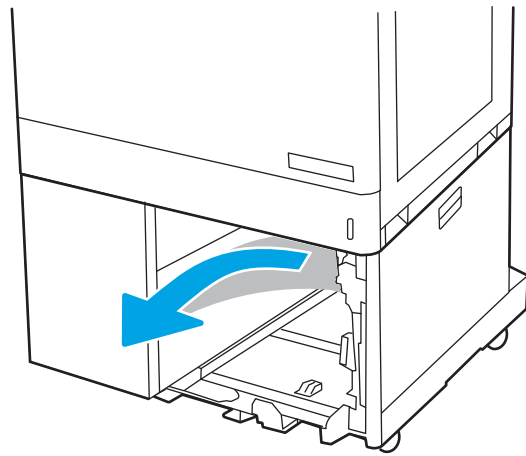

6. Open the lower-right door.

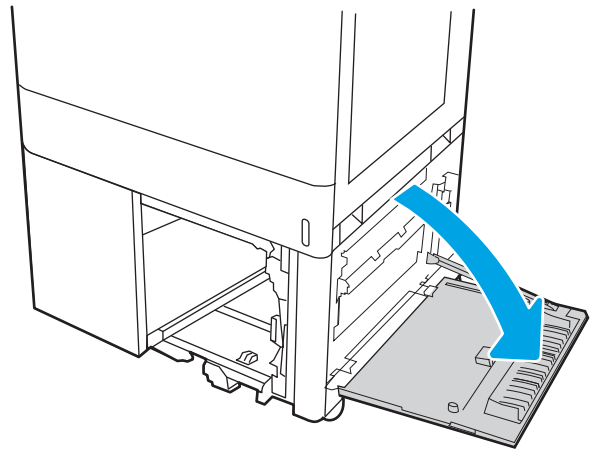

7. Remove any damaged sheets.

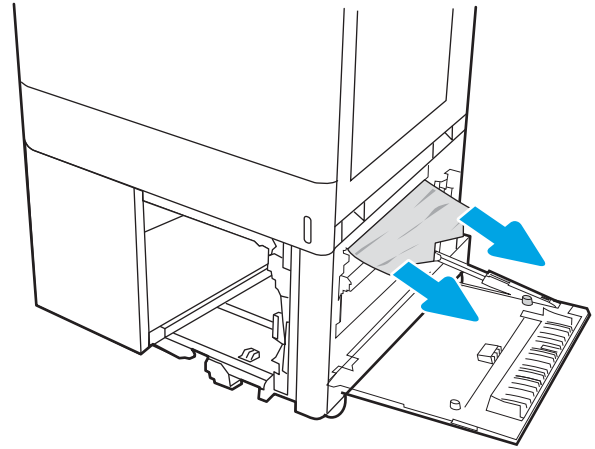

8. Close the lower-right door, and then install and close the right HCL tray.

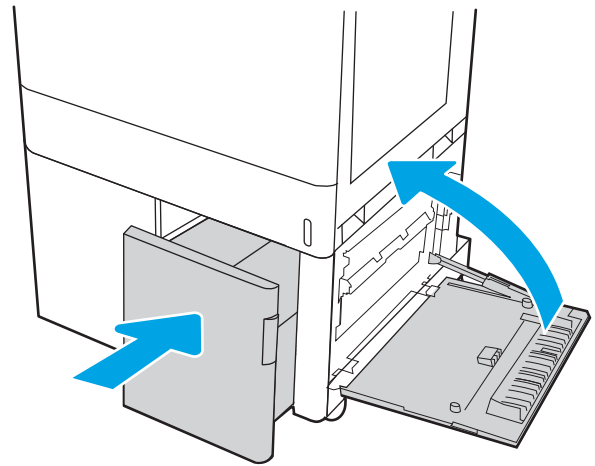

9. Open the right door.

**CAUTION:** Do not touch the transfer roller. Contaminants can affect print quality.

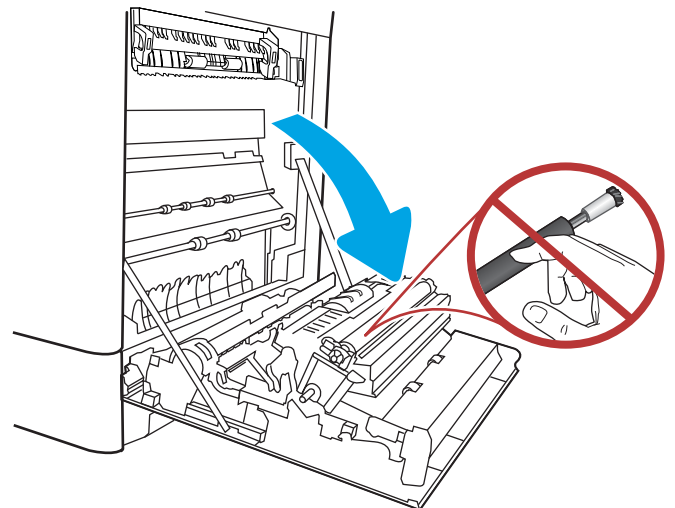

10. Gently pull out any jammed paper.

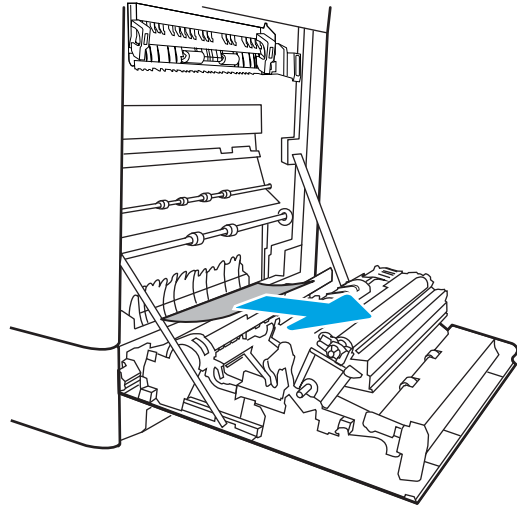

11. Gently pull out any jammed paper in the duplex area on the right door.

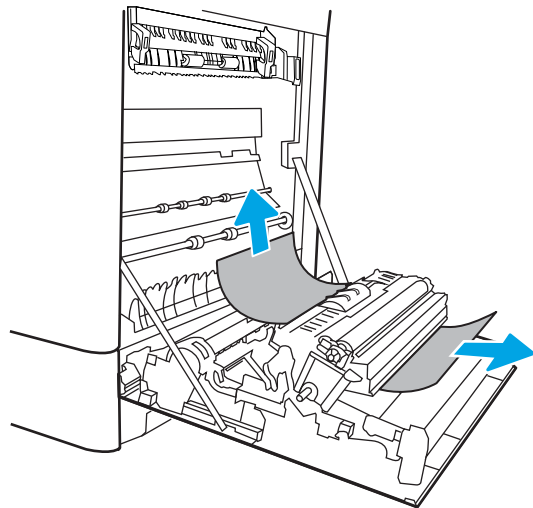

12. If paper is visible entering the bottom of the fuser, gently pull downward to remove it.

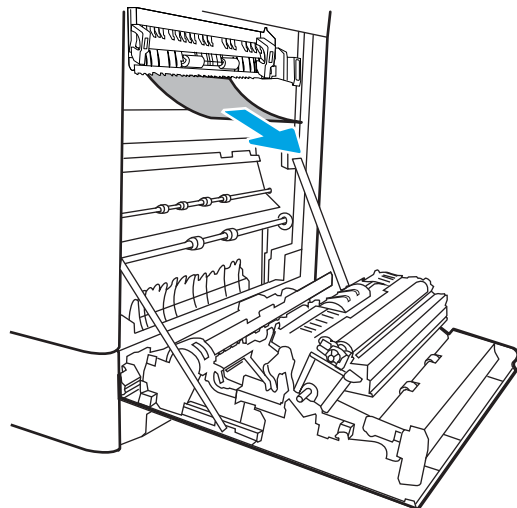



13. Paper could be jammed inside the fuser where it would not be visible. Grasp the fuser handles, squeeze the release levers, lift up slightly, and then pull straight out to remove the fuser.

**CAUTION:**  The fuser can be hot while the printer is in use. Wait for the fuser to cool before handling it.

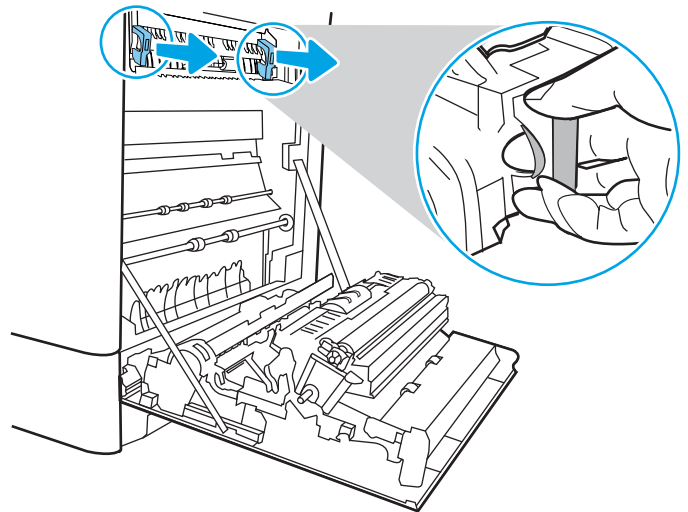

14. Open the jam-access door on the fuser. If paper is jammed inside the fuser, gently pull it straight up to remove it. If the paper tears, remove all paper fragments.

**CAUTION:**  Even if the body of the fuser has cooled, the rollers that are inside could still be hot. Do not touch the fuser rollers.

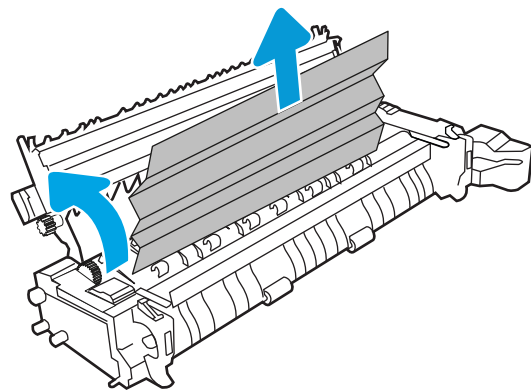

15. If paper is jammed as it enters the output bin, gently pull the paper out to remove it.

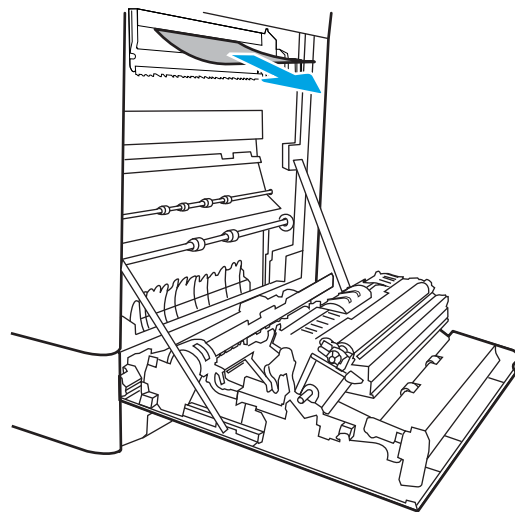

16. Close the jam-access door on the fuser, and push the fuser completely into the printer until it clicks into place.

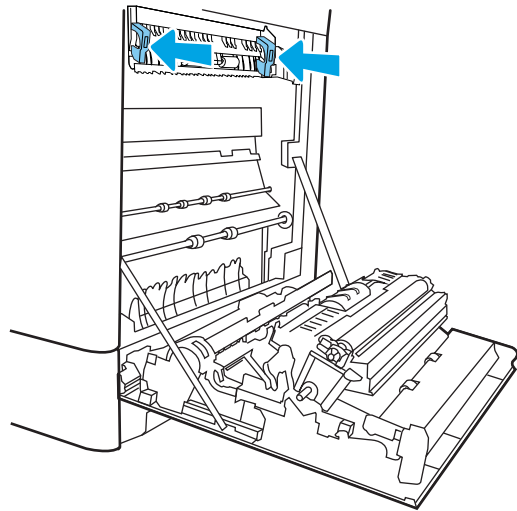

17. Close the right door.

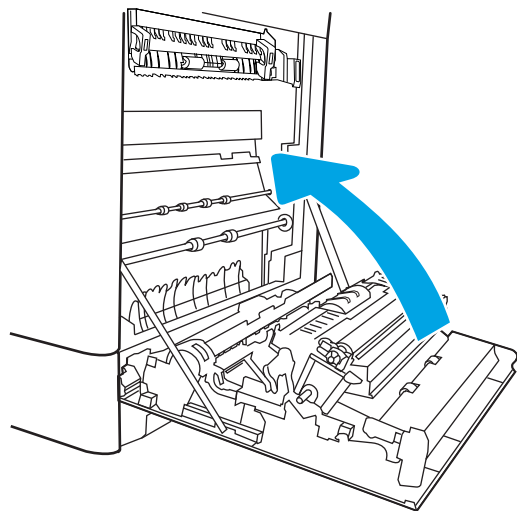

18. Open the upper-right door.

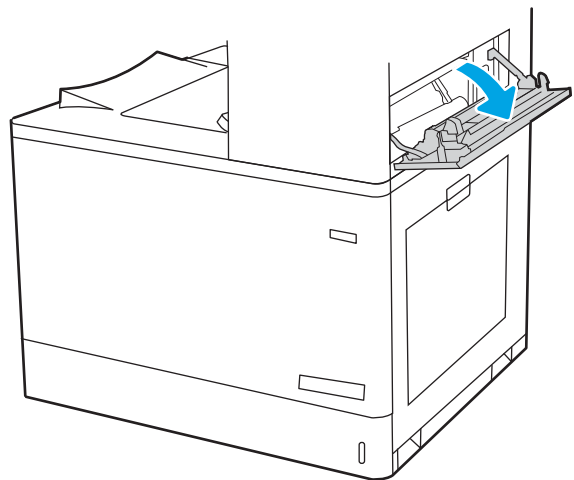

19. Gently pull out any jammed paper.

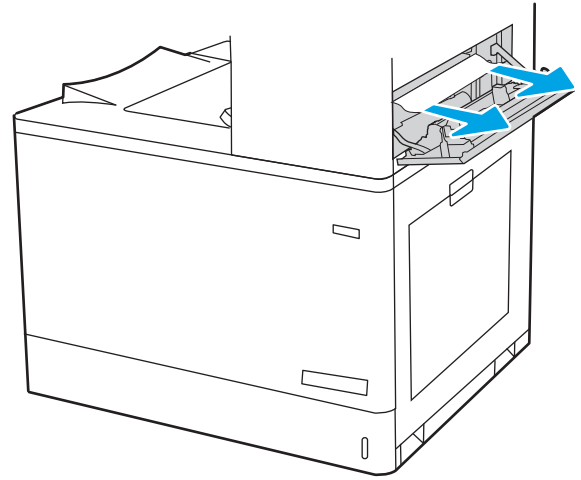

20. Close the upper-right door.

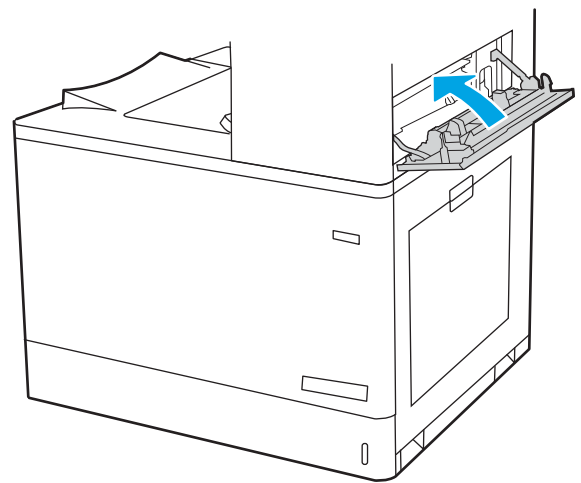

21. If paper is visible in the output bin, grasp the leading edge and gently remove it.

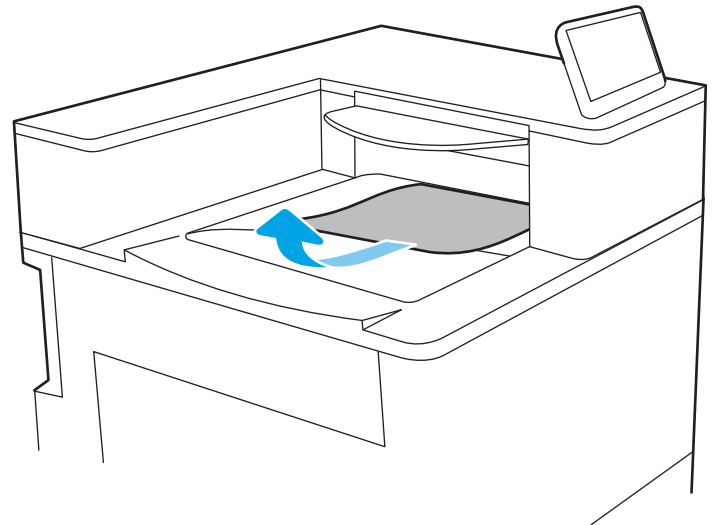

# Resolving color print quality problems

Use the information below to troubleshoot print-quality, color-quality, and image-quality problems on HP Color LaserJet Enterprise printers.

- [Introduction](#)
- [Troubleshoot print quality](#)

## Introduction

The troubleshooting steps can help resolve the following defects:

- Blank pages
- Black pages
- Colors that do not align
- Curled paper
- Dark or light bands
- Dark or light streaks
- Fuzzy print
- Gray background or dark print
- Light print
- Loose toner
- Missing toner
- Scattered dots of toner
- Skewed images
- Smears
- Streaks

## Troubleshoot print quality

To resolve print-quality issues, try these steps in the order presented.

- [Update the printer firmware](#)
- [Print from a different software program](#)
- [Check the paper-type setting for the print job](#)
- [Check toner-cartridge status](#)
- [Print a cleaning page](#)
- [Visually inspect the toner cartridge or cartridges](#)
- [Check paper and the printing environment](#)
- [Try a different print driver](#)

To troubleshoot specific image defects, see [Troubleshoot image defects](#).

### Update the printer firmware

Try upgrading the printer firmware.

For instructions, go to [www.hp.com/support](http://www.hp.com/support).

### Print from a different software program

Try printing from a different software program.

If the page prints correctly, the problem is with the software program from which you were printing.

## Check the paper-type setting for the print job

Check the paper type setting when printing from a software program and the printed pages have smears, fuzzy or dark print, curled paper, scattered dots of toner, loose toner, or small areas of missing toner.

- [Check the paper type setting on the printer](#)
- [Check the paper type setting \(Windows\)](#)
- [Check the paper type setting \(macOS\)](#)

### Check the paper type setting on the printer

Check the paper type setting on the printer control panel, and change the setting as needed.

1. Open the tray.
2. Verify that the tray is loaded with the correct type of paper.
3. Close the tray.
4. Follow the control panel instructions to confirm or modify the paper type settings for the tray.

### Check the paper type setting (Windows)

Check the paper type setting for Windows, and change the setting as needed.

1. From the software program, select the **Print** option.
2. Select the printer, and then click the **Properties** or **Preferences** button.
3. Click the **Paper/Quality** tab.
4. From the **Paper Type** drop-down list, click the **More...** option.
5. Expand the list of **Type is:** options.
6. Expand the category of paper types that best describes your paper.
7. Select the option for the type of paper you are using, and click the **OK** button.
8. Click the **OK** button to close the **Document Properties** dialog box. In the **Print** dialog box, click the **OK** button to print the job.

### Check the paper type setting (macOS)

Check the paper type setting for macOS, and change the setting as needed.

1. Click the **File** menu, and then click the **Print** option.
2. In the **Printer** menu, select the printer.
3. By default, the print driver displays the **Copies & Pages** menu. Open the menus drop-down list, and then click the **Finishing** menu.
4. Select a type from the **Media Type** drop-down list.
5. Click the **Print** button.

## Check toner-cartridge status

Follow these steps to check the estimated life remaining in the toner cartridges and if applicable, the status of other replaceable maintenance parts.

- [Step one: Print the Supplies Status Page](#)
- [Step two: Check supplies status](#)

### Step one: Print the Supplies Status Page

The supplies status page indicates the cartridge status.

1. From the Home screen on the printer control panel, select the [Reports](#) menu.
2. Select the [Configuration/Status Pages](#) menu.
3. Select [Supplies Status Page](#), and then select [Print](#) to print the page.

### Step two: Check supplies status

Check the supplies status report as follows.

1. Look at the supplies status report to check the percent of life remaining for the toner cartridges and, if applicable, the status of other replaceable maintenance parts.

Print quality problems can occur when using a toner cartridge that is at its estimated end of life. The supplies status page indicates when a supply level is very low. After an HP supply has reached the very low threshold, HP's premium protection warranty on that supply has ended.

The toner cartridge does not need to be replaced now unless the print quality is no longer acceptable. Consider having a replacement available to install when print quality is no longer acceptable.

If you determine that you need to replace a toner cartridge or other replaceable maintenance parts, the supplies status page lists the genuine HP part numbers.

2. Check to see if you are using a genuine HP cartridge.

A genuine HP toner cartridge has the word "HP" on it, or has the HP logo on it. For more information on identifying HP cartridges go to [www.hp.com/go/learnaboutequipment](http://www.hp.com/go/learnaboutequipment).

## Print a cleaning page

During the printing process paper, toner, and dust particles can accumulate inside the printer and can cause print-quality issues such as toner specks or spatter, smears, streaks, lines, or repeating marks.

Follow these steps to clean the printer paper path:

1. From the Home screen on the printer control panel, select the [Support Tools](#) menu.
2. Select the following menus:

- a. [Maintenance](#)
  - b. [Calibration/Cleaning](#)
  - c. [Cleaning Page](#)
3. Select [Print](#) to print the page.

A **Cleaning...** message displays on the printer control panel. The cleaning process takes a few minutes to complete. Do not turn the printer off until the cleaning process has finished. When it is finished, discard the printed page.

## Visually inspect the toner cartridge or cartridges

Follow these steps to inspect each toner cartridge:

1. Remove the toner cartridge from the printer, and verify that the sealing tape has been removed.
2. Check the memory chip for damage.
3. Examine the surface of the green imaging drum.

---

 **CAUTION:** Do not touch the imaging drum. Fingerprints on the imaging drum can cause print-quality problems.

---

4. If you see any scratches, fingerprints, or other damage on the imaging drum, replace the toner cartridge.
5. Reinstall the toner cartridge and print a few pages to see if the problem has resolved.



## Check paper and the printing environment

Use the following information to check the paper selection and the printing environment.

- [Step one: Use paper that meets HP specifications](#)
- [Step two: Check the environment](#)
- [Step three: Set the individual tray alignment](#)

### Step one: Use paper that meets HP specifications

Some print-quality problems arise from using paper that does not meet HP specifications.

- Always use a paper type and weight that this printer supports.
- Use paper that is of good quality and free of cuts, nicks, tears, spots, loose particles, dust, wrinkles, voids, staples, and curled or bent edges.
- Use paper that has not been previously printed on.
- Use paper that does not contain metallic material, such as glitter.
- Use paper that is designed for use in laser printers. Do not use paper that is designed only for use in Inkjet printers.
- Use paper that is not too rough. Using smoother paper generally results in better print quality.

### Step two: Check the environment

The environment can directly affect print quality and is a common cause of print-quality or paper-feeding issues. Try the following solutions:

- Move the printer away from drafty locations, such as open windows or doors, or air-conditioning vents.
- Make sure the printer is not exposed to temperatures or humidity outside of printer specifications.
- Do not place the printer in a confined space, such as a cabinet.
- Place the printer on a sturdy, level surface.
- Remove anything that is blocking the vents on the printer. The printer requires good air flow on all sides, including the top.
- Protect the printer from airborne debris, dust, steam, grease, or other elements that can leave residue inside the printer.

### Step three: Set the individual tray alignment

Follow these steps when text or images are not centered or aligned correctly on the printed page when printing from specific trays.

1. From the Home screen on the printer control panel, select the [Settings](#) menu.
2. Select the following menus:

- a. [Copy/Print](#) or [Print](#)
  - b. [Print Quality](#)
  - c. [Image Registration](#)
3. Select [Tray](#), and then select the tray to adjust.
  4. Select [Print Test Page](#), and then follow the instructions on the printed pages.
  5. Select [Print Test Page](#) again to verify the results, and then make further adjustments if necessary.
  6. Select [Done](#) to save the new settings.

## Try a different print driver

Try a different print driver when printing from a software program and the printed pages have unexpected lines in graphics, missing text, missing graphics, incorrect formatting, or substituted fonts.

Download any of the following drivers from the HP Web site: [www.hp.com/support/colorljE85055](http://www.hp.com/support/colorljE85055).

**Table 6-2** Print drivers

Driver	Description
HP PCL.6 driver	If available, this printer-specific print driver supports older operating systems like Windows XP and Windows Vista. For a list of supported operating systems, go to <a href="http://www.hp.com/go/support">www.hp.com/go/support</a> .
HP PCL 6 driver	This printer-specific print driver supports Windows 7 and newer operating systems that support version 3 drivers. For a list of supported operating systems, go to <a href="http://www.hp.com/go/support">www.hp.com/go/support</a> .
HP PCL-6 driver	This product-specific print driver supports Windows 8 and newer operating systems that support version 4 drivers. For a list of supported operating systems, go to <a href="http://www.hp.com/go/support">www.hp.com/go/support</a> .
HP UPD PS driver	<ul style="list-style-type: none"> <li>• Recommended for printing with Adobe software programs or with other highly graphics-intensive software programs</li> <li>• Provides support for printing from Postscript emulation needs, or for Postscript flash font support</li> </ul>
HP UPD PCL 6	<ul style="list-style-type: none"> <li>• Recommended for printing in all Windows environments</li> <li>• Provides the overall best speed, print quality, and printer feature support for most users</li> <li>• Developed to align with Windows Graphic Device Interface (GDI) for best speed in Windows environments</li> <li>• Might not be fully compatible with third-party and custom software programs that are based on PCL 5</li> </ul>

# Solve wired network problems

Check the following information to resolve wired network issues.

- [Introduction](#)
- [Poor physical connection](#)
- [The computer is unable to communicate with the printer](#)
- [The printer is using incorrect link and duplex settings for the network](#)
- [New software programs might be causing compatibility problems](#)
- [The computer or workstation might be set up incorrectly](#)
- [The printer is disabled, or other network settings are incorrect](#)

## Introduction

Certain types of problems can indicate there is a network communication problem. These problems include the following issues:

## Poor physical connection

Check the cable connections.

1. Verify that the printer is attached to the correct network port using a cable of the correct length.
2. Verify that cable connections are secure.
3. Look at the network port connection on the back of the printer, and verify that the amber activity light flashes indicating network traffic, and the green link-status light is continuously lit indicating a network link.
4. If the problem continues, try a different cable or port on the hub.

## The computer is unable to communicate with the printer

Verify that the printer is communicating with the network and your computer.

1. Test network communication by pinging the network.
  - a. Open a command-line prompt on your computer.
    - For Windows, click **Start**, click **Run**, type `cmd`, and then press `Enter`.
    - For macOS, go to **Applications**, then **Utilities**, and open **Terminal**.
  - b. Type `ping` followed by the IP address for your printer.
  - c. If the window displays round-trip times, the network is working.
2. If the ping command failed, verify that the network hubs are on, and then verify that the network settings, the printer, and the computer are all configured for the same network (also known as subnet).
3. Open the printer properties and click the **Ports** tab. Verify that the current IP address for the printer is selected. The printer IP address is listed on the printer configuration page.

4. If you installed the printer using the HP standard TCP/IP port, select the box labeled **Always print to this printer, even if its IP address changes**.
5. If you installed the printer using a Microsoft standard TCP/IP port, use the printer's hostname instead of the IP address.
6. If the IP address is correct, delete the printer and then add it again.
7. Reinstall the printer software and driver.

## The printer is using incorrect link and duplex settings for the network

HP recommends leaving these settings in automatic mode (the default setting). If you change these settings, you must also change them for your network.

## New software programs might be causing compatibility problems

Verify that any new software programs are correctly installed and that they use the correct print driver.

## The computer or workstation might be set up incorrectly

An incorrectly configured computer can cause issues with printing.

1. Check the network drivers, print drivers, and the network redirection settings.
2. Verify that the operating system is configured correctly.

## The printer is disabled, or other network settings are incorrect

Check the network settings.

1. Review the printer's configuration/networking pages to check the status of the network settings and protocols.
2. Reconfigure the network settings if necessary.

# Index

## Symbols/Numerics

- 2 x 550-sheet trays
  - loading 41
- 2,700-sheet HCl paper trays
  - loading 48
- 550-sheet trays
  - jams 116
  - loading 34

## A

- accessories
  - ordering 60
- acoustic specifications 10, 15
- AirPrint 79, 81
- alternative letterhead mode 19, 26, 27, 33, 34, 40, 41, 47, 48, 53
- Android devices
  - printing from 79, 82

## B

- bin, output
  - locating 4
- Bonjour
  - identifying 88
- browser requirements
  - HP embedded Web Server 88

## C

- cartridge
  - replacing 62
- cleaning
  - paper path 163
- control panel
  - help 106
  - locating 4
  - locating features on the touchscreen control panel 7
- customer support
  - online 105

## D

- default gateway, setting 96
- deleting
  - stored jobs 75, 78
- dimensions, printer 10, 13
- document feeder
  - paper-feeding problems 109
- double-sided printing
  - Mac 72
  - Windows 68
- drivers, supported 10
- duplex printing
  - Mac 72
- duplex printing (double-sided)
  - settings (Windows) 68
  - Windows 68
- duplexer
  - jams 116
- duplexing
  - manually (Mac) 72
  - manually (Windows) 68

## E

- easy-access USB printing 83
- electrical specifications 10, 15
- Embedded Web Server
  - changing network settings 96
  - changing printer name 96
  - opening 96
- Embedded Web Server (EWS)
  - assigning passwords 100, 101
  - features 88
  - network connection 88
- energy use, optimizing 103
- envelopes
  - orientation 19, 20
- envelopes, loading 54
- Ethernet (RJ-45)
  - locating 5

- Explorer, versions supported
  - HP Embedded Web Server 88

## F

- formatter
  - locating 5
- fuser
  - jams 116

## G

- gateway, setting default 96
- general configuration
  - HP Embedded Web Server 88, 90

## H

- hard disks
  - encrypted 100, 102
- HCl. *See* high-capacity input paper trays
- Help button
  - locating 7
- help, control panel 106
- Hi-Speed USB 2.0 printing port
  - locating 5
- Home button
  - locating 7
- HP Customer Care 105
- HP Embedded Web Server
  - changing network settings 96
  - changing printer name 96
  - general configuration 88, 90
  - HP Web Services 88, 90, 93
  - information pages 88, 90
  - network settings 88, 90, 93
  - opening 96
  - other links list 88, 90, 95
  - print settings 88, 90, 91
  - security settings 88, 90, 92

- supplies settings 88, 90, 92
- troubleshooting tools 88, 90, 92
- HP Embedded Web Server (EWS)
  - features 88
  - network connection 88
- HP ePrint 79
- HP ePrint software 79
- HP Web Jetadmin 104
- HP Web Services
  - enabling 88, 90, 93

- I**
- image quality
  - check toner-cartridge status 163, 165
- Information button
  - locating 7
- information pages
  - HP Embedded Web Server 88, 90
- interface ports
  - locating 5
- Internet Explorer, versions supported
  - HP Embedded Web Server 88
- IP Security 100, 102
- IPsec 100, 102
- IPv4 address 96
- IPv6 address 96

- J**
- jams
  - 2 x 550 paper trays 116
  - 550-sheet trays 116
  - auto-navigation 116, 117
  - causes of 116, 117
  - duplexer 116
  - fuser 116
  - high-capacity input paper trays 116
  - locations 116
  - output bin 116
  - right door 116
  - Tray 1 116
  - Tray 2 116
- Jetadmin, HP Web 104
- jobs, stored
  - creating (Windows) 75
  - deleting 75, 78
  - Mac settings 75
  - printing 75

- L**
- label, orientation 56
- labels
  - printing (Windows) 68
  - printing on 56
- labels, loading 56
- LAN port
  - locating 5
- left door
  - locating 5
- loading
  - paper in the 2 x 550-sheet trays 41
  - paper in the 2,700-sheet HCl paper trays 48
  - paper in the 550-sheet trays 34
  - paper in Tray 1 19
  - paper in Tray 2 27
- local area network (LAN)
  - locating 5
- lock
  - formatter 100, 102

- M**
- Mac driver settings
  - Job Storage 75
- managing network 96
- manual duplex
  - Mac 72
  - Windows 68
- memory
  - included 10
- memory chip (toner)
  - locating 61
- minimum system requirements
  - macOS 11
  - Windows 11
- mobile printing
  - Android devices 79, 82
- mobile printing, software supported 10
- multiple pages per sheet
  - printing (Mac) 72
  - printing (Windows) 68

- N**
- Near Field Communication printing 79, 80

- Netscape Navigator, versions supported
  - HP embedded Web Server 88
- network
  - printer name, changing 96
  - settings, changing 96
  - settings, viewing 96
- network duplex settings, changing 96
- network link speed settings, changing 96
- network settings
  - HP Embedded Web Server 88, 90, 93
- networks
  - default gateway 96
  - HP Web Jetadmin 104
  - IPv4 address 96
  - IPv6 address 96
  - subnet mask 96
  - supported 10
- NFC connect and print 79, 80

- O**
- on/off button
  - locating 4
- online help, control panel 106
- online support 105
- operating systems, supported 10, 11
- ordering
  - supplies and accessories 60
- other links list
  - HP Embedded Web Server 88, 90, 95
- output bin
  - clear jams 116
  - locating 4

- P**
- pages per minute 10
- pages per sheet
  - selecting (Mac) 72
  - selecting (Windows) 68
- paper
  - jams 116, 117
  - loading the 2 x 550-sheet trays 41
  - loading the 2,700-sheet HCl paper trays 48

- loading the 550-sheet trays 34
- loading Tray 1 19
- loading Tray 2 27
- selecting 163, 167
- Tray 1 orientation 19, 20
- paper jams
  - 2 x 550 paper trays 116
  - 550-sheet trays 116
  - duplexer 116
  - fuser 116
  - high-capacity input paper trays 116
  - locations 116
  - output bin 116
  - right door 116
  - Tray 1 116
  - Tray 2 116
- paper pickup problems
  - solving 109, 112
- paper type
  - selecting (Windows) 68
- paper types
  - selecting (Mac) 72
- paper, ordering 60
- ports
  - locating 5
- potential shock hazard 2
- power
  - consumption 10, 15
- power connection
  - locating 5
- power switch
  - locating 4
- power usage
  - 1 watts or less 103
- print drivers
  - Linux 11
  - macOS 11
  - UNIX 11
  - Windows 11
- print drivers, supported 10
- print media
  - loading in Tray 1 19
- print on both sides
  - Mac 72
  - manually, Windows 68
  - Windows 68
- print settings
  - HP Embedded Web Server 88, 90, 91
- printing
  - from USB storage accessories 83
  - stored jobs 75
- printing on both sides
  - settings (Windows) 68
- private printing 75
- product number
  - locating 5
- R**
- replacing
  - toner cartridges 62
  - toner-collection unit 64
- reset factory settings 107
- right door
  - jams 116
- RJ-45 port
  - locating 5
- S**
- security settings
  - HP Embedded Web Server 88, 90, 92
- security
  - encrypted hard disk 100, 102
- serial number
  - locating 5
- settings
  - reset to factory (default) settings 107
- Sign In button
  - locating 7
- Sign Out button
  - locating 7
- sleep delay
  - setting 103
- special paper
  - printing (Windows) 68
- specifications
  - electrical and acoustic 10, 15
- speed, optimizing 103
- storage, job
  - Mac settings 75
- store print jobs 75
- stored jobs
  - creating (Mac) 75
  - creating (Windows) 75
  - deleting 75, 78
  - printing 75
- storing jobs
  - with Windows 75
- subnet mask 96
- supplies
  - low threshold settings 107
  - ordering 60
  - replacing toner cartridges 62
  - replacing toner-collection unit 64
  - using when low 107
- supplies settings
  - HP Embedded Web Server 88, 90, 92
- support
  - online 105
- supported operating systems 11
- system requirements
  - HP Embedded Web Server 88
  - minimum 10
- T**
- TCP/IP
  - manually configuring IPv4
    - parameters 96
  - manually configuring IPv6
    - parameters 96
- technical support
  - online 105
- toner cartridge
  - components 61
  - low threshold settings 107
  - using when low 107
- toner cartridges
  - replacing 62
- toner-collection unit
  - information 64
  - replacing 64
- touchscreen
  - locating features 7
- transparencies
  - printing (Windows) 68
- Tray 1
  - jams 116
  - loading envelopes 54
  - paper orientation 19, 20
- Tray 2
  - jams 116
  - loading 27
- trays
  - capacity 10
  - included 10

- locating 4
- use alternative letterhead mode  
26, 33, 40, 47, 53
- troubleshooting
  - check toner-cartridge status 163,  
165
  - jams 116, 117
  - network problems 169
  - paper feed problems 109
  - wired network 169
- troubleshooting tools
  - HP Embedded Web Server 88,  
90, 92
- two-sided printing
  - settings (Windows) 68

## U

- USB port
  - enabling 83, 84, 86
  - locating 5
- USB storage accessories
  - printing from 83

## W

- web browser requirements
  - HP Embedded Web Server 88
- websites
  - customer support 105
  - HP Web Jetadmin, downloading  
104
- weight, printer 10, 13
- Wi-Fi Direct Print 10, 79, 80



## Free Manuals Download Website

<http://myh66.com>

<http://usermanuals.us>

<http://www.somanuals.com>

<http://www.4manuals.cc>

<http://www.manual-lib.com>

<http://www.404manual.com>

<http://www.luxmanual.com>

<http://aubethermostatmanual.com>

Golf course search by state

<http://golfingnear.com>

Email search by domain

<http://emailbydomain.com>

Auto manuals search

<http://auto.somanuals.com>

TV manuals search

<http://tv.somanuals.com>