

Operating Manual

for

Husqvarna

Domestic Sewing Machine

Class 12 (CB-N)



Husqvarna Vapenfabriks Aktiebolag
Husqvarna

Sw

This little handbook is intended to teach you how your Husqvarna sewing-machine works, how it should best be looked after, and also how the various attachments, which accompany the machine, or, which can be obtained, can best be employed.

It is of importance for you to study the handbook so that your sewing-machine will, as we hope, be both a pleasure and a help — a loyal and valuable assistant for many years.

Your sewing-machine is a capital which if rightly used will give you good interest. But incorrect treatment or lack of care not only diminishes the pleasure and the help it can give you, but even contributes to shortening the life of the machine.

You should, therefore, try to become really familiar with your machine's function and employment by a thorough study of the handbook. It will undoubtedly be well worth while.

**The thread, needle, and shuttle form
the stitches.**

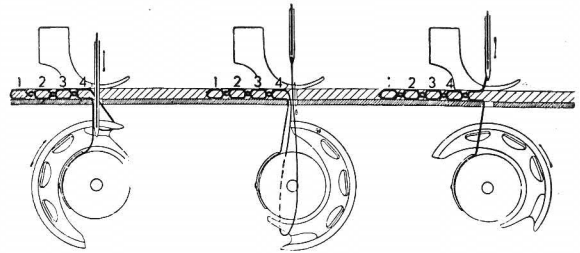

A seam sewn by machine is a series of firm interlacements of the upper and under threads (stitches) which are formed by the needle pushing the upper thread through the material and down through the hole in the throat plate. When the needle has reached its lowest point it rises again, whereupon the upper thread forms a loop sufficiently large for the shuttle to catch in, widen, and pass through together with the under thread. As soon as the shuttle has passed through the loop, the upper thread is tightened, and the stitch has been formed.

For this type of machine only needles of class 705 should be used; for sewing fur class 705 L, with cutting edge. Both the class number and size are usually stamped on the butt of the needle. On one side of the needle there is a

lengthwise depression or groove in which the thread goes when the needle works up and down in the material; on the opposite side, where the butt is flattened, the groove is quite short and on this side of the needle the loop is formed through which the shuttle should pass.

On inserting the needle the needle bar is raised to its highest point, the thumb screw at the bottom of the needle bar is loosened and the butt of the needle with its flat side turned towards the balance wheel is pushed up as far as it will go, after which the thumb screw is tightened securely.

It is essential for forming stitches, amongst other things, that the needle is correctly inserted in the machine. Never use crooked or blunt needles and do not keep discarded needles.

Choose thread suitable for the material and a needle suitable for the thread.

A seam sewn by machine should, as much as possible, blend in with the weave of the material and the thread should, therefore, not be so coarse that the seam stitches do not sink into the surface of the material. The under thread should preferably be one number finer than the upper; in any case it should not be thicker. The coarseness of the needle should be determined by the thread; neither so coarse that it makes marks in the material, nor so fine that the thread cannot easily pass through the eye of the needle.

Table of materials, thread, and needles.

Description of material and class of work	Size of respective threads	Needle No
Very fine work on very thin materials	200 cotton thread 200 embroidery and darning thread	60
Thin nainsook, muslin, fine linen and silk stockinette	90-150 cotton thread 32 machine silk 80-200 embroidery and darning thread	70
Silk stockinette, table linen, finer madapolams, nainsook, silk and woollen fabrics	60-80 cotton thread 28-30 machine silk and spool silk 30-60 embroidery and darning thread	80
Heavier silk, closer woven madapolams and woollen fabrics	50 cotton thread 24-26 machine silk and spool silk 16-20 embroidery and darning thread	90
Sheetings, woollen and cotton fabrics	40 cotton thread 18-22 machine silk 12 embroidery and darning thread	100
Canvas, khaki, and heavier coatings	30 cotton thread 14-16 machine silk	110
Thickings and heavier work	26 cotton thread 60-80 linen thread	120
Extra heavy work	16-20 cotton thread 50 linen thread	130

Winding the bobbin.

The bobbin can be wound either when sewing is in progress or after disconnecting the sewing mechanism. In the latter case, the balance wheel is disconnected by turning the coupling disc on the right-hand side of the wheel towards you, by means of the grip shown in the

illustration beneath. The balance wheel now revolves without operating the mechanism. From the reel on the right-hand spool-pin the thread is passed through the thread guide (1) (see illustration on the next page) downwards between the tension discs (2) from left to right, after which the bobbin is placed on the spindle (3) of the bobbin winder, so that the little pin on

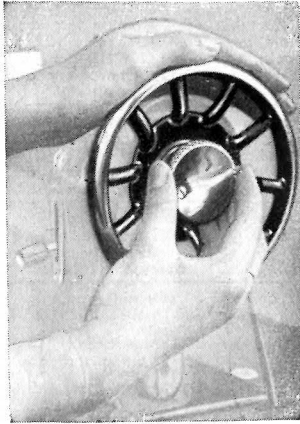

the same engages in the hole in the right-hand side of the bobbin. The thread is then threaded from inside outwards through the tracer or one of the holes in the sides of the bobbin, and is drawn out about two inches and held fast. The thread end should be held until a few turns have been wound and then it is cut off. The winder disconnects automatically as soon as the bobbin is full.

If when winding, the thread winds more on one side than the other, this may be regulated by shifting the thread guide (5) on the table in the direction in which there is least thread.

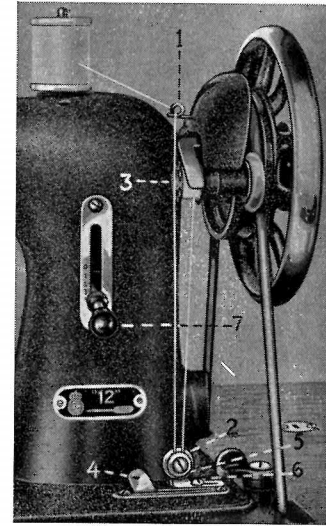

Setting in and removing the bobbin from the shuttle.

The bobbin is placed in the bobbin case as is shown in the illustration on the next page so that when the thread is pulled the bobbin will move in the direction of the arrow. The thread is passed down into the slot in the edge of the

case, under the tension spring on the outside and under the hook, which projects down into the oblong hole of the case, and then into the thread-guide-hole of the spring. The thread is drawn out to a length of about 3 inches, after which the bobbin and bobbin case are inserted in the shuttle. In order to keep the bobbin from falling out of the case, the hinged flap (1) on the front of the bobbin case should be kept un-

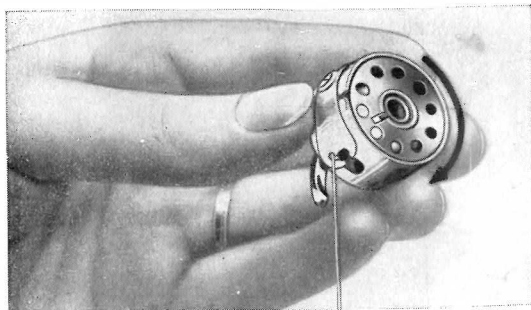

clasped. On placing the bobbin and bobbin case in the shuttle, the needlebar should be raised to the highest point and the slide over the shuttle on the machine table drawn out, so that the shuttle mechanism is visible. The bobbin case should be held firmly with the same grip that is shown in the adjoining illustration, and pressed as far as it will go on to the pin which is provided with a button and is to be found in the centre of the shuttle, making certain that the finger-like projection of the bobbin

case fits into the recess in the upper part of the shuttle frame (2), after which the flap (1) is closed down. By pressing on the front of the bobbin case, it can be seen if it has been pushed in sufficiently.

Allow the end of the thread from the bobbin case to hang loosely and close the slide in the machine table.

In the case of machines with folding

upper part, the bobbin case can most conveniently be inserted in the shuttle from below through the flap for this purpose, which can be found in the protective tray.

The bobbin case can be removed from the shuttle after the needle bar has been raised to its highest point, and the hinged flap (1) has been opened with the thumb and forefinger of the left hand.

Tension on the lower thread.

The tension on the lower thread can be regulated by means of a so-called tension spring

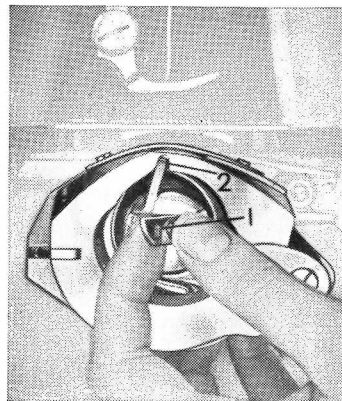

on the outside of the bobbin case. If the tension is to be regulated, this is done with the aid of the little screw-driver which should be carefully inserted in the screw in the middle of the spring. If the screw is turned in a clockwise direction, the tension on the under thread is increased, and it is decreased on being turned in the opposite direction. Adjustment should

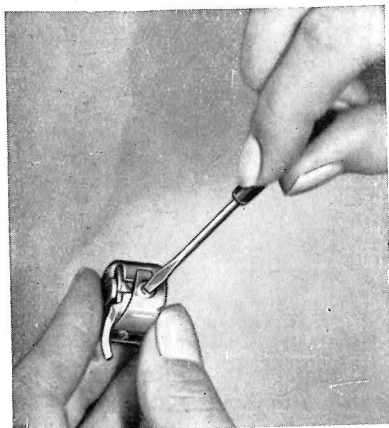

consist of a $\frac{1}{4}$ or a $\frac{1}{2}$ turn, which usually is sufficient.

On delivery the under thread is adjusted for normal tension, which need only be changed if very thin or particularly thick material is used. If it is necessary to change very often from thread to silk, it would be advisable to procure an extra bobbin case so that each bobbin case can be kept at its own tension.

Threading and tension in the upper thread.

When threading the upper thread, the take-up lever (5 on the illustration beneath) should be raised to its highest point. The thread is passed from the reel through the thread-guide (1) down between the tension discs (2) into the hook of the slack thread regulating spring (3) under the thread guide (4), then upwards to the take-up lever (5), through which the thread passes from right to left, down through the eyelet (6) and into the thread-guide on the needle bar (7), after which the thread is threaded from left to right through the eye of the needle and is drawn out to a length of about 3 inches.

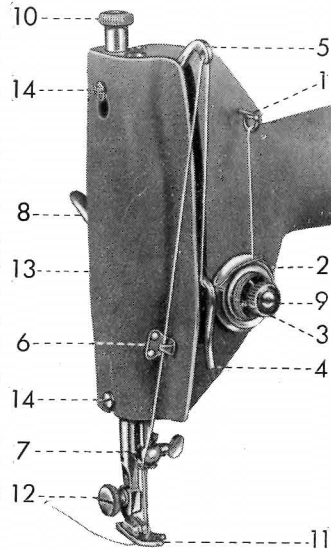

The tension in the upper thread is regulated by the grooved screw (9) on the tension discs of the tension regulator. There are no graduations marked on the screw but correct tension can be judged by the appearance of the stitches; the red mark on the screw, however, can

serve as a basis when regulating the tension. Tension on the thread is increased when the nut (9) is turned in a clockwise direction and lessened, when it is turned in the opposite direction.

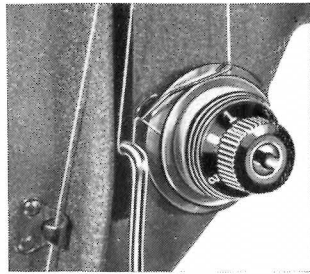

Tension in the thread is an important detail when sewing. For thick or hard materials tight tension in the upper thread is required, in order to draw the under thread up into the fabric; whilst too tight tension on thin or loosely woven material causes puckering and sometimes can even cut the material. On the other hand too slack tension on thick materials causes seams to »gape«.

How correct and incorrect tension affect the stitching is shown by the diagrams below:



Diagram 1.

Diagram 1. shows correct relations between the upper and lower thread.

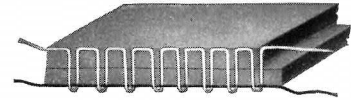

Diagram 2.

Diagram 2. shows that the tension in the upper thread has been too slack, or that in the under thread too tight.

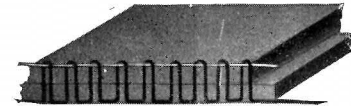

Diagram 3.

Diagram 3. shows the opposite. The under thread has been so loose, that it has been drawn right up through the material so that the stitches interlock on the upper surface.

Presser foot, throat plate and feed motion.

The design of the presser foot varies according to the work, for which it is intended. Two different presser feet are supplied with the machine; one with a jointed foot, mounted on the machine, and a narrower one in the attachment box, intended for fine pleating, quilting, etc., where it is necessary to be able to see the seam while sewing with a straight guide.

There are, as well, special presser feet for hemming, for chain stitch, for braiding, for sewing rugs (rya), etc.

The same rule applies to all of them, that the pressure of the presser foot on the material towards the feed should be adjusted according to the type of the material; a hard fabric requires greater pressure of the pressure foot, a loosely woven or thin material requires less pressure so that feeding is carried out correctly. Thin, soft fabrics can, as well, be injured by the teeth of the feed motion if the pressure is too heavy.

The pressure on the presser foot is regulated by tightening or loosening the grooved nut on the presser bar (see 10 in the illustration on page 11).

The throat plate is the plate through which the needle goes up and down in the so-called needle-hole. It is important that the sides of the needle-hole are kept smooth and even, so

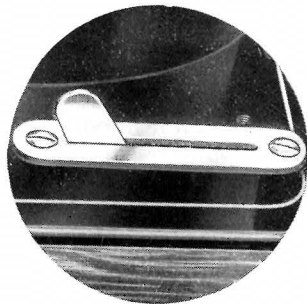

that neither the needle nor the thread are injured. Never drag the material when sewing, because that bends the needle and can even injure the edges of the needle-hole in the throat plate.

The feed motion works in the recess in the throat plate and feeds the material forward. When darning or embroidering the feed motion must be lowered by pushing the lever, which is on the right of the machine table, to the right.

Length of stitches.

The length of the stitch and the direction of the feed is regulated by the lever with a knob, which is on the right of the machine. At the bottom behind the knob is a scale indicating lengths of stitches for ordinary sewing.

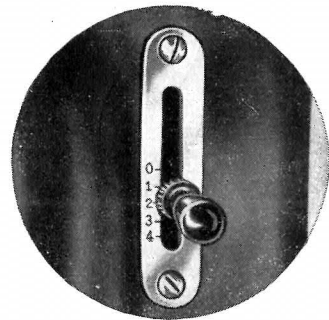

The stitches should be longer for thick material than for thin but never shorter than that the stitch covers at least two threads of the material; through it should be mentioned that the same length of stitch looks shorter in thick material than in thin.

Treadling and sewing.

To be able to sew it is first necessary to acquire complete command of the treadling movement, so that even stitching can be made

with the feet, and the machine stopped or started again in the right direction, no matter what the position.

To acquire this familiarity beginners are recommended to disconnect the balance wheel (see the upper illustration on page 6) and to

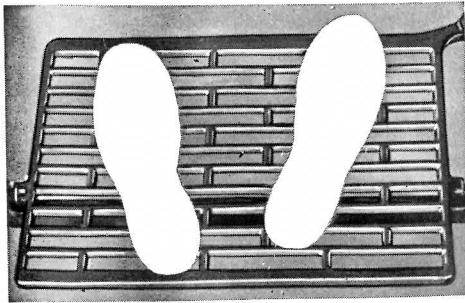

practise treading. The feet should be placed on the treadle so that they can easily follow the movements of the treadle with alternate heel and toe pressure. It is necessary to practise until the machine can be kept in uniform motion and treading is thoroughly mastered.

It may be advisable, before beginning to sew, for beginners to practise on a piece of material but without needle and thread in the machine. The material is placed under the presser foot, which is carefully lowered, and the machine is started by turning the balance wheel towards you and continuing with treading. By turning the stuff to right or left, necessary pro-

ficiency in guiding the material in the desired direction is acquired.

Before threading the needle, it should be ascertained that the take-up lever (5 in the illustration on page 11) is raised to its highest point, the needle is then threaded and the free end of the upper thread is held loosely in the left hand while the right turns the balance wheel towards

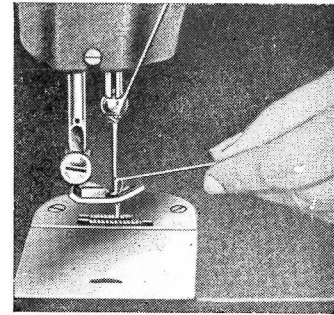

you until the needle has descended and ascended again. The upper thread has then caught up the lower thread. The cloth is placed under the presser foot, the needle is brought down into the material, the upper and lower threads are pushed backwards, the presser bar is carefully lowered, and the seam can be commenced.

When the sewing is finished and the material is to be taken out of the machine, it should be done when the needle bar and take-up lever are raised to their highest point. The material is

moved to the left and the thread cut off against the cutter, at the back of the face plate.

Never allow the machine to be in action with the presser foot down, without having first placed some material under it.

Cleaning and lubricating.

Head.

If the machine is to be kept in good condition, it must be cleaned and oiled about once a month when used moderately and more often, if it is used daily.

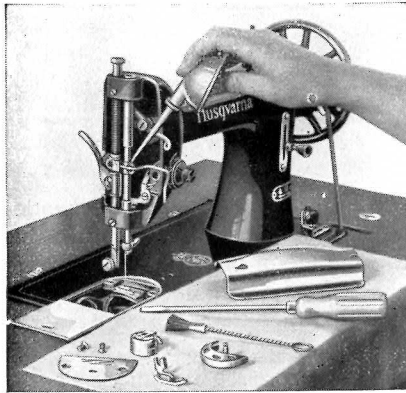

Only first-class sewing-machine oil should be used. Vegetable oils, such as salad oil, castor oil, etc., should therefore not be used, as they clog the bearings and are not easily dissolved.

Before oiling it is advisable to test the oil-can on a rag. It should emit a drop at a time on being lightly pressed, no more is needed at each lubricating hole.

Cleaning and oiling are best done in a definite order, so that there is less risk of any place being forgotten. The face plate is un-

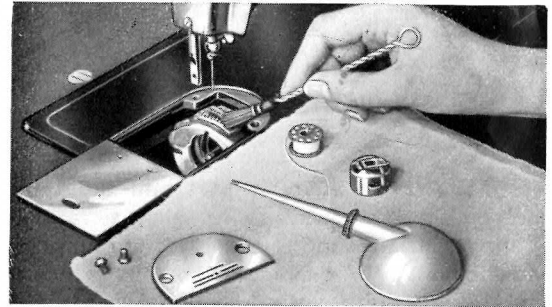

screwed, taken away and wiped clean from dust and fluff. All machine parts inside the plate are brushed clean with the little brush, which is to be found in the attachment box, and the needle bar, pressure foot and take-up lever are then oiled.

It is easiest to get at the feed mechanism by unscrewing and removing the throat plate, whereupon the teeth of the feed mechanism are cleaned with the brush. No oil should be used here.

Afterwards it is the turn of the shuttle race and shuttle. In order to clean these, it is neces-

sary to raise the upper part of the machine, which can be done after the belt has been



loosened from the upper part and the table knob pushed sideways. The shuttle race is opened with the knob attached for the purpose, and the shuttle is removed. The shuttle race is first cleaned with the brush, and afterwards with a match or other object, which is not too sharp, and round which a rag or piece of cotton is wound. The shuttle is cleaned, after the bobbin case has been removed, and oiled by rubbing the shuttle's gliding surface with a rag, on which there is a drop of oil. In order to avoid oil on the thread or material, it is important that lubricating is not carried out in any other way. The centre peg on the shuttle should, on the other hand, be given a drop of oil.

It sometimes happens that the tension in the under thread changes through dust or fluff collecting on the tension springs. It is then

necessary to unscrew the spring and clean it with a rag, brush, or match, but not with the

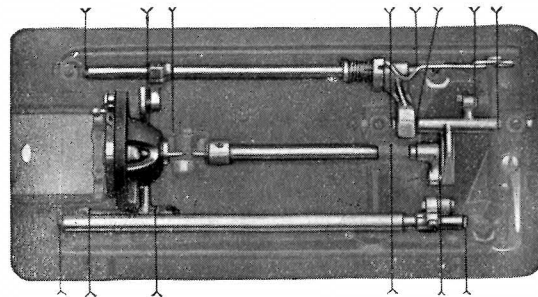

screw-driver. Do this carefully and place all the parts on a piece of white stuff, so that they do not get lost.

As the upper part of the machine is now raised, the other movable parts under the ma-

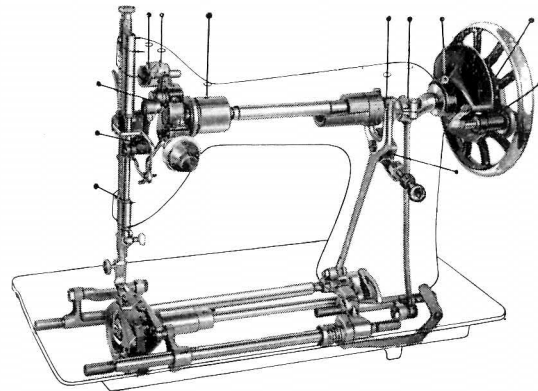

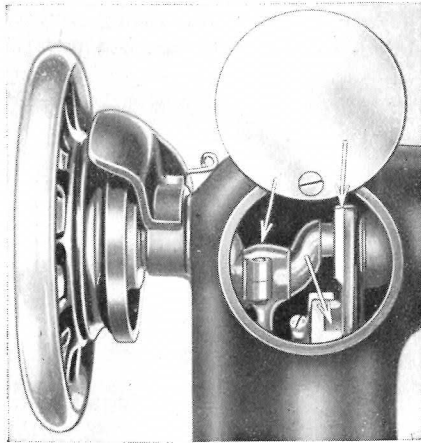

chine table should be oiled. The arrows on the illustration on page 21 show where this should take place.

The upper part of the machine is put back into position, and oiling is continued in the lubricating holes, which are indicated by the arrows on the illustration on page 21.

The round flap on the back of the upper part is unscrewed with the screw-driver, so that the three points inside can also be oiled.

Adjusting and lubricating the stand.

In the event of either of the pitman rod bearings working loose, it should be adjusted in the following manner:

In case of undue play in the bearings this

refers usually to the lower bearing, and consequently this bearing is to be adjusted. This is done by means of the nut, which is placed under the treadle, being loosened by a spanner. The bearing screw in the nut is then tightened so much that the bearing is no longer working loose, but the bearing must, of course, run quite smoothly. Then the nut is again tightened up.

For the upper pitman rod bearing loosen the nut on the rod, after which the rod, which forms a set screw for the bearing cups, should be loosened a little. One of the bearing cups is quite lightly tightened on the balls, after which tighten up again first the rod and then the nut.

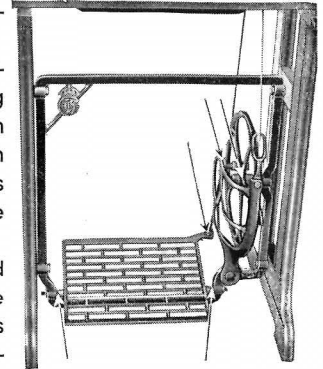

Afterwards the band wheel and treadle remain, which should be oiled at the places indicated by the arrows and the same applies to the upper and lower bearings of the pitman rod.

After cleaning and oiling the machine, it is advisable to let it run rapidly for a few minutes, the superfluous oil is then wiped off, and the machine is perfectly ready for continued sewing.

Sewing-machine motor.

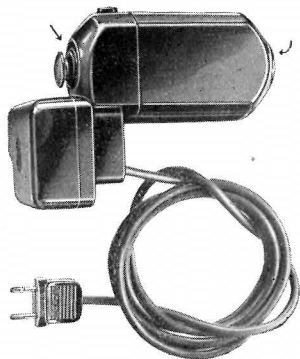

Universal motor 1/20 h. p. for a sewing speed of up to approximately 1,000 stitches per minute with regulator resistance.

Instructions for motor sewing-machines.

The speed of the sewing-machine is regulated by means of a knee regulating arm, with the exception of treadle machines fitted with motors, when the speed is regulated by the pressure of the foot on the treadle. In the case of machines with a foot, the arm is mounted on the axis which projects from the regulating device.

The motor belt must not be too tight, as in that case it will brake the motor which thereby increases the difficulty of starting at low speeds.

The belt may be made tighter or looser by raising or lowering the motor bracket. In this way the screw is loosened, which fixes the bracket to the arm of the sewing-machine. After regulating the belt tension, the screw should be tightened.

Treatment and care of the sewing-machine motor.

Oiling. If the motor is used regularly, it should be oiled sparingly once a year with sewing-machine oil in the lubricating holes, which are to be found at each bearing. When the motor leaves the factory, the bearings are filled with oil.

If there is too little oil in the bearings, the motor does not run silently but rattles and the bearings get hot. If there is too much oil, it is easily driven into the motor, and can injure its windings and commutator.

The carbon brushes. The carbon brushes are the parts of the motor which are most subject to wear. At least once a year they should be examined to see whether they are in order. This is done by unscrewing the insulating cap, which covers the outer end of the brush holders, (the motor having been disconnected from the mains), whereupon the carbon brush and the adhering spiral spring are removed from the brush holder. If the brush is worn down so far, that only about $\frac{1}{4}$ of an inch is left of the square part, it should be replaced by a new one. When a used brush is put in again, care should be taken that the rounded-off part of the surface in contact with the commutator is in the same position as before and that the spiral spring is pulled out sufficiently far (when the brush is inserted it should project about $\frac{3}{8}$ of an inch outside the brush holder, before the cap is

screwed on again), so that the pressure of the brush on the commutator is sufficient. If the motor does not run well, although the brushes have been adjusted in the way described, expert advice should be obtained.

How simple faults arise and how they can be remedied easily.

If the machine does not work satisfactorily, do not immediately think that it is the fault of the machine. Use the following list of faults as an aid to discovering the cause of the trouble, afterwards you can, in most cases, remedy it yourself.

If you are unable with the aid of these directions to remedy the fault, we would recommend you to consult the nearest Husqvarna depot, or one of their authorised agents. We warn you very seriously not to consult any other, possibly not sufficiently experienced, sewing-machine mechanics, who are not responsible for the make, and who often charge too much for both repairs and spare parts. Nor does our guarantee for the sewing-machine apply if any other than our mechanics, and authorised agents carry out repairs, or adjust the machine.

If it is necessary to send the machine to the depot, the upper part should be detached from the table, and well packed in a box, so as to avoid injury. If straw or shavings are used, the machine must first be thoroughly protected with paper. Write to the depot when the machine is despatched, and enclose, if possible, a specimen of sewing, showing the faulty action of the machine; the defect can then be detected more rapidly.

When ordering parts or attachments, the broken part should be enclosed or details given of the machine's specification (which are given on the front of the upper part of the machine under the stitch regulator) and the production number. Our agents have the most of the common parts in stock, or can obtain them.

Machine working heavily.

1. Belt too tight. Stretch it, or procure a new one, if it is too short.
2. Shuttle race clogged with fluff, which must be removed. See under the heading »Skip stitches», page 30.
3. Machine lubricated with inferior, or unsuitable oil, which has dried hard. The oil can be dissolved by pouring a few drops of paraffin in each lubricating hole, and allowing the machine to run for a few minutes before lubricating it with proper sewing-machine oil. If this treatment does no good, the machine must be sent to our depot, or our agent, for cleaning.

4. The bobbin winder is not disconnected, but is in engagement with the wheel during sewing.
5. The thread has become entangled in some way.
6. The treadle or the balance wheel's bearings are too tightly adjusted and must be loosened with a spanner.

Bobbin winding irregularly.

1. The thread has come out of the tension discs.
2. The fastener of the tension discs has worked out of its right position.

The machine not feeding material.

1. See that the stitch regulator is at the zero mark. See page 15, «Length of stitches».
2. See that the feed motion is not lowered for darning.
3. The presser foot is pressing too lightly. Increase pressure by screwing up the grooved nut on the presser bar. (No. 10 on page 11).

Sewing mechanism ceasing to operate whilst sewing.

1. The coupling discs is not screwed sufficiently tightly. See pages 5—6.
2. The belt is too slack. Should be shortened somewhat. Keep the belt free from oil.

The upper thread will not pick up the under thread.

1. The needle is turned the wrong way. The flat side of the butt should be turned to the right. See page 4.

The upper thread breaking.

1. The needle is incorrectly inserted. The flat side of the butt should be turned to the right. See page 4.
2. Incorrectly threaded upper thread. See page 11.
3. Tension in the thread too tight. See page 11.
4. Bent, blunt, or otherwise defective needle. Change the needle!
5. The point of the shuttle damaged. If the damage is slight, the shuttle point can be ground. If the damage is considerable, the shuttle must be changed for a new one.
6. The needle hole in the throat plate damaged, so that sharp edges, or «burrs» have been formed. Have the throat plate repaired, or, if it is very much damaged, replace it with a new one.
7. The thread is too coarse for the needle. See page 5.

The under thread breaking.

1. The thread tension spring on the bobbin case is too tight. See page 9.

2. The needle hole in the throat plate is damaged, so that sharp edges, or »burrs« have been formed. Have the throat plate repaired or, if it is very much damaged, replace it with a new one.
3. Inferior (brittle) thread. A good thread must be strong and free from knots and other irregularities, so that it resists normal thread tension.

The upper thread looping on under side of material.

1. The upper thread is incorrectly threaded.
2. The front tension disc sticks.
3. Dirt has penetrated between the tension discs.
4. The tension in the upper thread is too slack. See pages 11—12.

The under thread looping on top of material.

1. The tension in the under thread is too slack or that in the upper thread is too tight. See pages 9—13.

The tension in under thread not sufficiently tight.

1. There is dirt under the tension spring of the bobbin case. Clean this.
2. The tension spring has been injured. Replace it.

Skip stitches.

1. The needle is not properly fixed.

2. The needle is incorrectly set. The flat side of the needle butt must be turned to the right. See page 4.
3. Bent or blunt needle. Change the needle.
4. The needle and thread are not suited to one another. See needle-and-thread table on page 5.
5. Knotted or uneven thread. Use only first-class thread.
6. The pressure of the presser foot ineffective. With regard to the regulation of this pressure see page 14.
7. Dirt in the tension mechanism of the upper or lower thread. Clean these.
8. Dirt or thread ends have got into the shuttle mechanism and penetrated in under the spring ring cover, causing the shuttle to wobble. Directions for cleaning the shuttle mechanism on page 20.

Ugly stitches — ugly seams.

1. Unevenly wound bobbin. See pages 6—7.
2. Too tight or too slack tension in the thread. The tension in the under thread should always be somewhat slacker than that in the upper. See page 9.
3. Incorrect proportions between the upper and under threads. The under thread should never be coarser than the upper thread, but should instead be somewhat finer. Page 4.
4. The thread is too coarse in relation to the material. See pages 4—5.

5. The needle is too fine or too coarse in relation to the thread. See pages 4—5.
6. Blunt or otherwise damaged needle. Change the needle. Never try to repair a blunt needle by grinding it.
7. Fluff and dirt between the upper tension discs or under the tension spring of the bobbin case. Remove fluff and dirt.

Irregular tension.

1. The bobbin has been unevenly wound. It should therefore be changed.

The stitches are uneven.

1. The feed motion is clogged with dirt. Clean it.
2. The teeth of the feed motion are worn. Replace with a new feed motion.
3. Pressure of presser foot too weak. See page 14.

The material puckering.

1. The tension in the upper thread, or possibly both tensions, too tight in relation to the material.
2. Pressure of presser foot is too heavy. See page 14.

The seams failing to hold the material together.

1. Both tensions of the threads are too slack in relation to the material. See pages 9—13.

Material tearing.

1. Too heavy pressure on presser foot. See page 14.

Needle striking against the throat plate or breaking.

1. The needle is bent, which may be due to pulling the material when sewing. Exchange the damaged needle for a new one. Never pull the material when sewing.

Adjustment and use of the attachments.

The foot hemmer

is attached after the presser foot has been removed. Where the hem is to be commenced, $\frac{1}{8}$ of an inch of the corner of the material should be clipped off and about $\frac{1}{2}$ an inch of the material folded by hand to the width of hem suited to the hemmer. Sew a stitch where the hem is to begin and, holding the thread ends in the right hand, with the help of the left hand guide the folded material into the spiral spring, at the same time as the presser bar is raised a little. The material is then drawn carefully back until the commencement of the hem is under

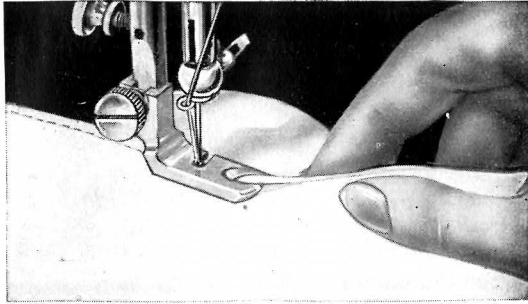

the needle of the machine and hemming can commence.

When hemming, the material is run into the spiral spring on the hemmer by holding up the outer edge of the material, in order to obtain an even hem. By lifting the material to the right, more material is run in; by sinking the hand and, at the same time, moving it to the left, less stuff is run into the hemmer. Hemmers

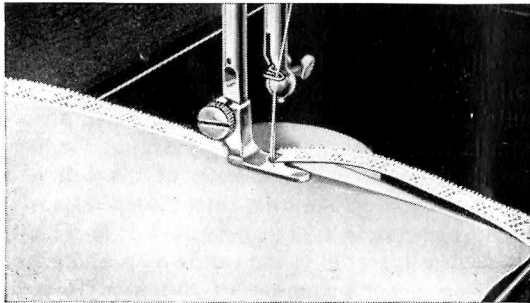

of different widths are used for the hemming of thin, medium, or thicker materials.

Hemming and sewing on lace at the same time with the hemmer (see illustration on page 34) is done by the material being inserted into the attachment in the manner described, and the lace being placed in the slot running from the needle hole. Be sure that the needle passes through both the lace and the hem.

Felling is done in two stages. At the first stage, the two pieces of material are placed with their right sides together, and the under

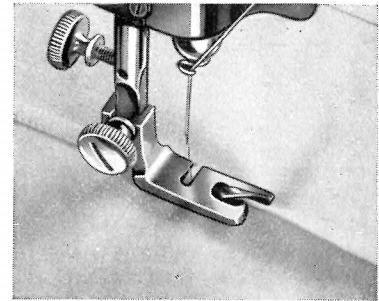

material projecting $\frac{1}{4}$ of an inch more to the right than the upper material. The two pieces of material are then inserted in the hemmer, in the same way as for ordinary hemming, but on folding care must be taken that the under material is felled singly without being folded.

At the second stage the material is spread out on both sides of the seam, which should be turned straight up. The seam is then inserted

once more into the hemmer, so that it falls to the left and is felled again with yet another seam.

The straight guide

is used when it is necessary to sew a seam parallel to the edge of the material. It can be

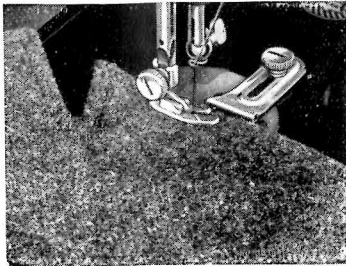

used for different types of work, such as sewing pin tucks, and other tucks, French seams, etc.

The straight guide is screwed to the machine table with the screw provided for the purpose.

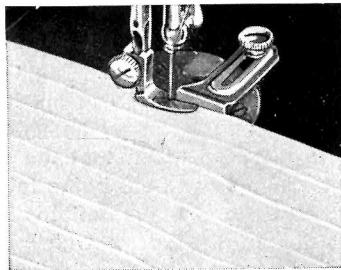

When sewing, the edge of the material should follow the guide closely. When sewing pin tucks, etc., the narrow presser foot should be used.

The presser foot.

Ordinary gathers are sewn on the machine by loosening the tension on the upper thread con-

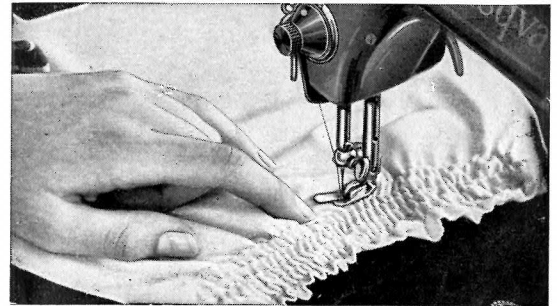
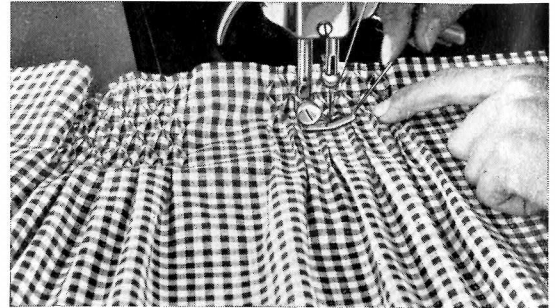

siderably. It is best to sew two rows of gathering with a small space between them. Both threads should then be drawn simultaneously to form gathers.

The length of the stitches must be in proportion to the material, somewhat longer stitches for ordinary sewing, but for thinner fabrics it looks best with shorter stitches.

Gathering with Lastex thread. Gathering which can be stretched is obtained by using Lastex thread as the under thread, which causes the material to be gathered while sewing.

When sewing matelassé the plain presser foot, without joint, should be used. As it would perhaps take too

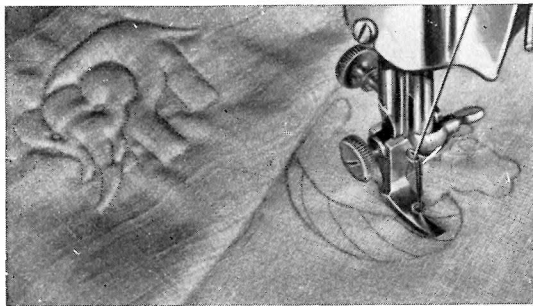

long time to describe this work in detail here, we recommend you to our shops and sewing courses, where tuition is given free of charge.

The ruffler

gathers while sewing. Firm gathers can be obtained by having the same tension on the upper and under threads, and adjustable gathers by

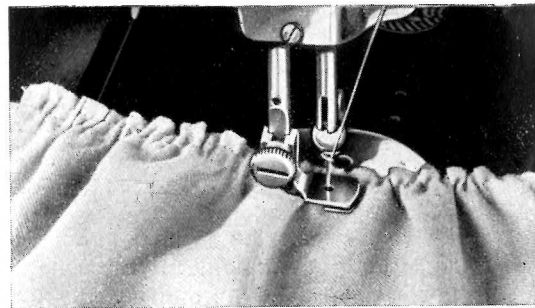
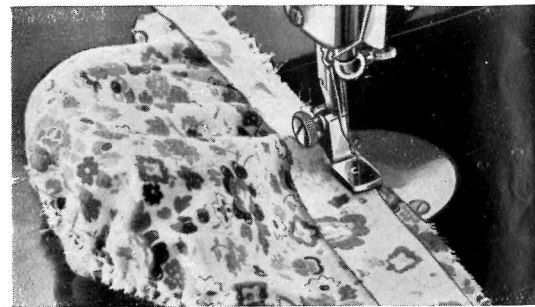

slightly loosening the tension on the upper thread.

The size of the gathers can be changed by setting the machine for longer or shorter stitches.

It can be seen in the adjoining illustrations how a wristband or a bias-band is placed from the left in the slot in the ruffler, and is sewn fast at the same time as the material is gathered, and also how gathering is done with two rows of gathering.

The darning foot.

When darning it is usual to use an embroidery frame, the inner hoop of which should be bound with cotton tape so that the material does not

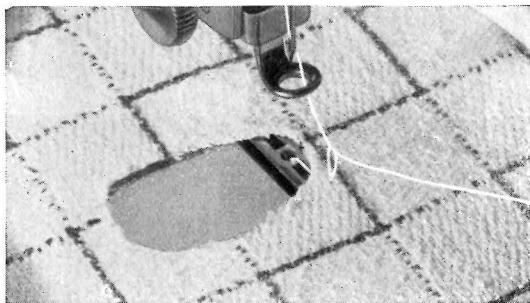

slip, and also for fastening tacking threads to when mending edges and corners. The material should be stretched tightly in the frame.

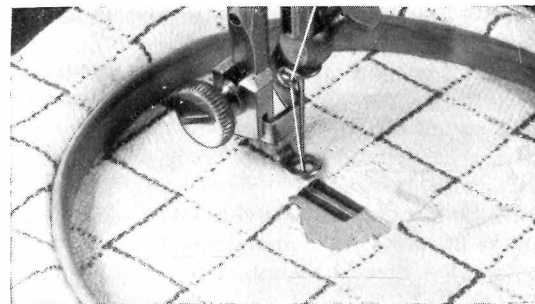

The darning foot should be attached at such a height that it only presses lightly on the material.

It is best to use mending cotton on reels for darning, No. 30 for coarser towels, No. 50 for toilet towels, and coarser table linen, and No. 200 for finer table linen, and darning patterns. Cotton stockinette should be darned with mending cotton, and for patching woollen ma-

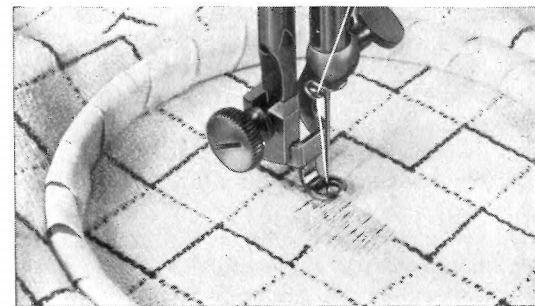

material a suitable shade of mending cotton or mercerised thread is used.

When commencing darning, the under thread is drawn up on the right side of the material, after which the presser bar is lowered. Both the threads should be held firmly while making the first four stitches.

The hole is first sewn over in the same direction as the weft in the material with long stitches, so that the darn shall not be too hard, the second time in the direction of the warp threads,

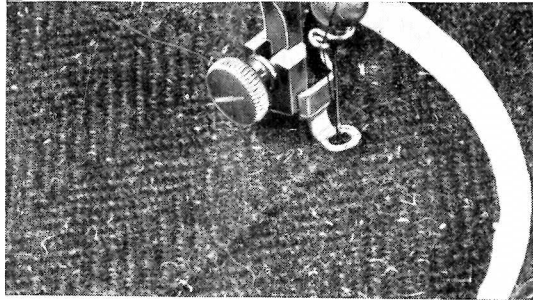

but this time with short stitches, so that the darn, after washing, shall be as invisible as possible. Long stitches can be made by treading rather slowly, and guiding the frame slowly.

Double gauze should be placed over larger holes, which is sewn down round the hole and cut off with a $\frac{1}{4}$ inch turning, after which the hole should be sewn over only once and in the direction of the warp threads.

When patching cotton fabrics, stockinette, or woollen fabrics a patch should be laid over the worn part and sewn fast with a $\frac{1}{4}$ inch turning, after which the torn material should be cut away, and the patch darned fast with fine stitches over the edge.

Appliqué and drawn-thread work, darning and stem stitch in various patterns can be done on

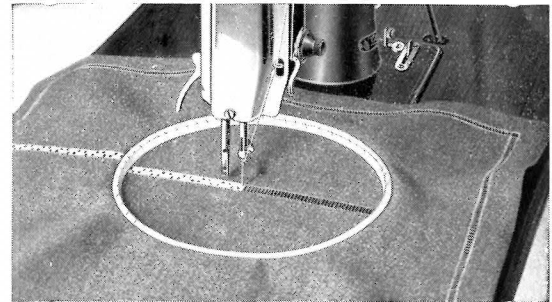
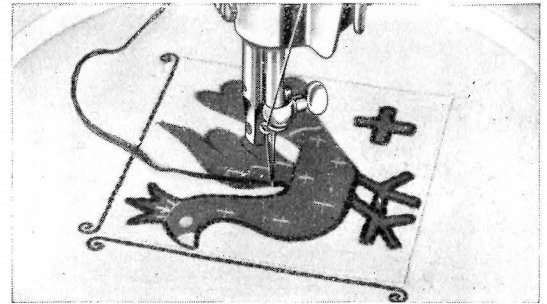

the sewing machine, but such sewing as marking requires good practise in treading to be able to treadle the machine slowly, and, at the same time, guide the frame with the work under the needle in the desired direction.

Smocking can be done with the aid of the straight guide, and the quilting guide.

Pleats of the desired width are sewn at regular intervals, with the help of the straight

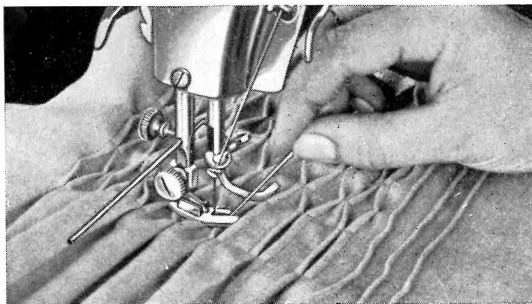
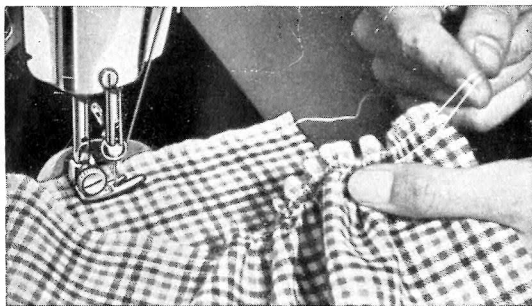

guide. The pleats are arranged two and two facing each other. With the aid of the quilting guide, rows of stitches are then sewn at equal distances right over the pleats so that box-pleats are formed. Afterwards the box-pleats are opened so that »diamonds» are formed by sewing a row of stitches between two previous rows of stitches and at the same time the pleats

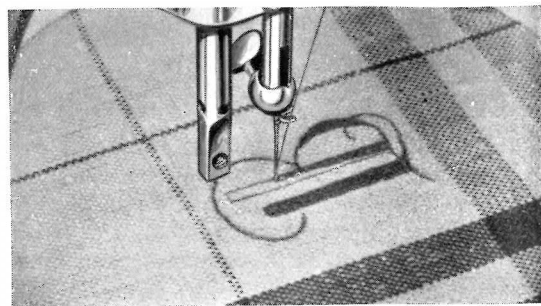

are guided with a needle in the opposite direction.

Quick marking. For this type of machine marking, as shown in the illustration, mending cotton or embroidery thread, of the type intended for sewing-machines, is used. The work is done without a presser foot, and with the feed motion lowered.

The monogram is drawn, the garment stretched on an embroidery frame, and the contour should then first be outlined with fine stitches, after

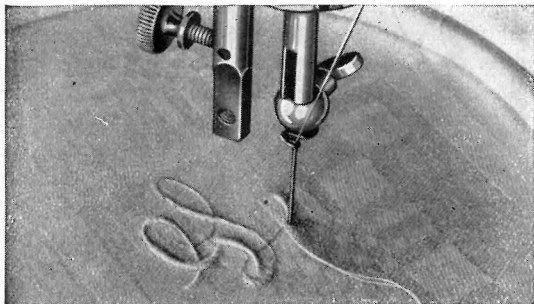

which the necessary parts are filled in with close rows of stitches.

With satin stitch the contours are first outlined, and are then filled in with shadow stitch, that is to say, rows of fine stitches backwards and forwards, touching each other. When an even padding has been obtained, satin stitch is sewn in the same way as by hand, straight over the lines.

The quilting guide.

By quilting is meant the sewing together of lining, wadding, and upper material; this stitching can be done in different patterns, straight lines, or round figures.

The quilting guide is used to obtain even spacing between the rows of stitches, no matter whether they are straight or curved.

The quilting guide is inserted in the hole on the presser bar and is screwed fast with the

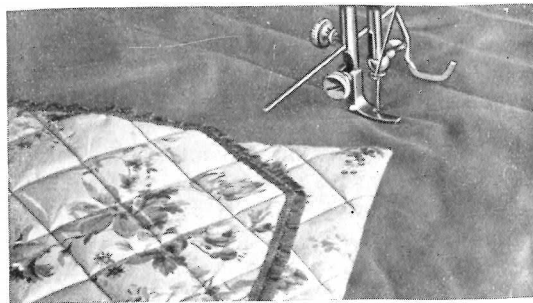

attachment screw after it has been adjusted for the desired spacing between the rows of stitches.

The binder.

The appliance is screwed fast to the machine table by means of the screw-hole provided, as shown in the illustration below, taking care that

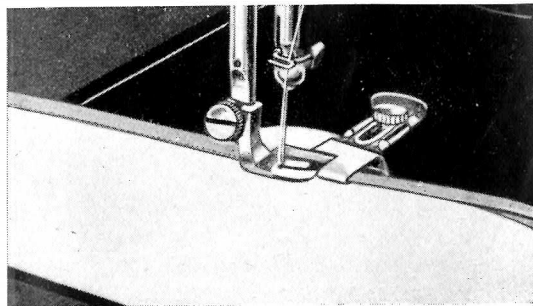

the turned-up part outside the slot points upwards and that the wide front part of the attachment is parallel with the presser foot.

The binding, which is to be sewn to the material, is folded over the edge of the latter, after which they are both inserted between the hooked portions of the binder. Care should be taken that the binding is sewn to the same width on both the upper and under sides of the material.

The braider

resembles an ordinary presser foot, but is provided with a bar in front, on which the braid is carried. When sewing, the braid should first be inserted so far that it reaches under the needle, the presser foot is then lowered and the braid sewn fast in the pattern desired, which can vary from the simplest rows on »sailors' collars» to artistic Greek key patterns.

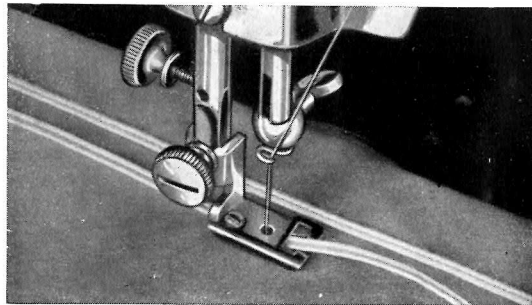

The adjustable hemmer

with which the width of the hem can be varied from $\frac{1}{4}$ to 1 inch is used with the usual presser foot still attached to the machine. The appliance is fixed just in front of the presser foot by inserting the pin on the hemmer in the furthest hole on the machine table; the hemmer is screwed fast in the other hole.

By loosening the screw and adjusting the pointer on the scale, the desired width of hem can be obtained. Fold the beginning of the

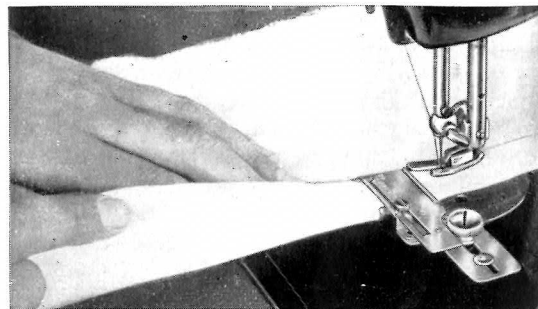

hem for $\frac{1}{2}$ an inch, and guide in the material from the left, allow it to follow the curve until the folded hem, which is formed, completely fills the space provided, and lower the presser foot. Take care that the stitching comes at the right place in the edge of the hem. If this is not the case, loosen the attachment screw and adjust the hemmer better.

Sewing is then commenced, whereby the edge of the material should be held up with the right hand, care being taken that sufficient material is fed into the hemmer for the width of the hem to remain constant.

The hemstitcher,



with which it is possible to sew a hemstitch which serves as decoration and for jointing.

Introduce the hemstitcher between two pieces of cloth so that the needle of the sewing machine when sewing operates between the legs of attachment. The eye should point to the right. Adjust the machine for short or long stitches according as the spacing between the rows of loop-sef the hemstitch is desired narrow or wide. The tension of the upper thread should be very loose — the looser the tension the wider the hemstich.

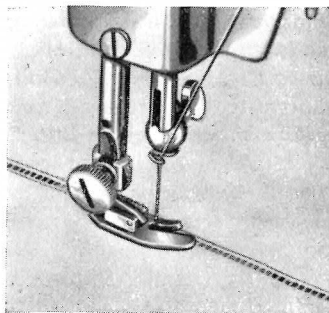
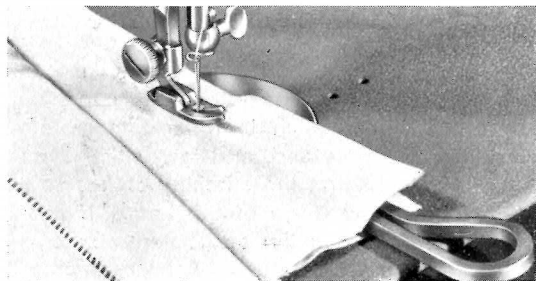

Lower the presser foot and sew the two pieces together. When the eye is almost reached, pull the hemstitcher towards yourself and continue sewing. Pull but the hemstitcher when the seam

is finished. Adjust the length of stitch and the tension of the upper thread for ordinary sewing. Pull the pieces of cloth apart so that the hemstitch becomes visible. Fold down the edges on either side of the hem and stitch quite close by, tuck in the edges of the hemstitch and hem them, if desired.

Combined ruffling and pleating attachment.

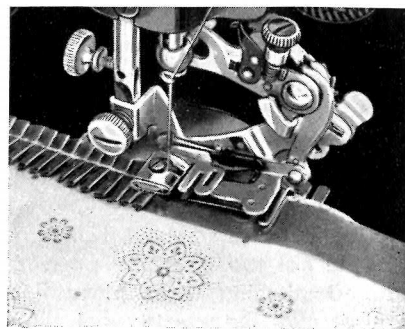

This appliance gathers, and, at the same time, opens out the gathers in closer-woven materials, and makes pleats up to $\frac{1}{4}$ of an inch in width. A band can simultaneously be gathered, and sewn on to a piece of material with this attachment, or a decorative braid or a bias tape can be sewn on.

Rug-making (rya technique).

When sewing rugs on the sewing-machine a so called weaver's reed is used, provided with a slot in the blade, and a loop for locking the smaller part of the reed, after the wool has been

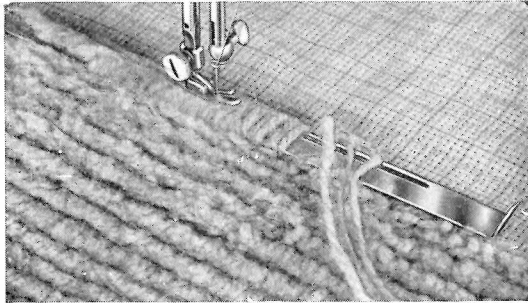

wound round it. As a foundation squared canvas or jute should be used.

The wool should be wound a few turns round the reed, but not too tight, the presser foot is lowered and stitching takes place backwards and forwards over the wound wool, through the

slot in the reed. After this has been done, the loop is unclamped, the reed is pushed forward, and more wool is wound on it. When wool has been sewn on for the whole length of the reed, it should be cut with a pair of scissors, without removing the work from the machine, and sewing is then continued, row upon row, until the required design is finished, whereupon the threads are secured with stitching backwards and forwards.

Our depots supply both designs and materials for mat-making.

The stocking darning

consists of a darning frame with a detachable spiral spring.

When the stocking is inserted in the darning frame the spiral spring should be removed, the

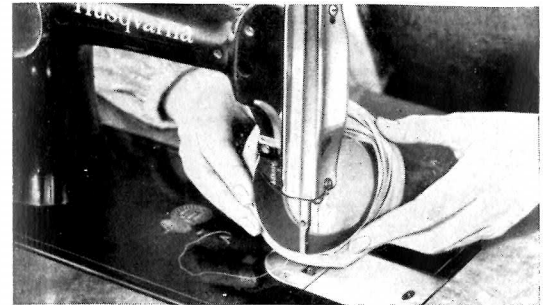

frame is placed with its narrowest side downwards against the right side of the stocking, so

that the hole comes exactly in the middle, and the stocking pushed up so that it lies round the darning frame. The spiral spring is attached so that the fabric is stretched. If the stocking is a very fine quality a piece of elastic should be used instead of the spiral spring.

In order to be able to be unhampered in the darning frame, the pr esser and screw should be removed. The darning frame is then placed under the needle bar, the under thread is drawn up with a stitch, and a row of stitching is sewn round the hole to hold it together, and darning takes place in the manner previously described. The thread ends should be cut off after the first row, so that they are not in the way.

The piping attachment

resembles an ordinary presser foot and replaces it when sewing, which should only be done on material, which is double, or with a lining.



An ordinary seam should be sewn first, after which the piping cord is placed between the layers of material close up to the stitching, and sewing continues with a new row of stitching, as near the first seam as possible, with the piping cord going under the left slot in the presser foot to be transferred to the other slot in the presser foot at the next seam, etc.

It can be seen in the above illustration that piping can be done in both straight or curved lines, and with one or more piping cords.

The tuckmarker

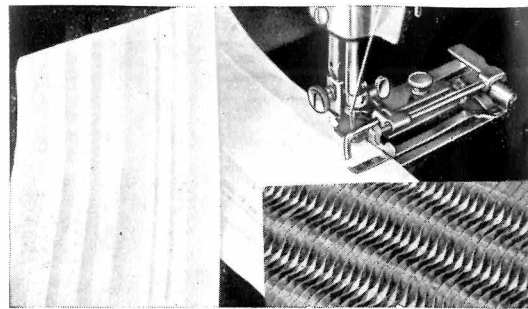

indicates the necessary distance between the tucks on the material, and is adjustable for tucks of different widths. Directions for use accompany each tuckmarker.

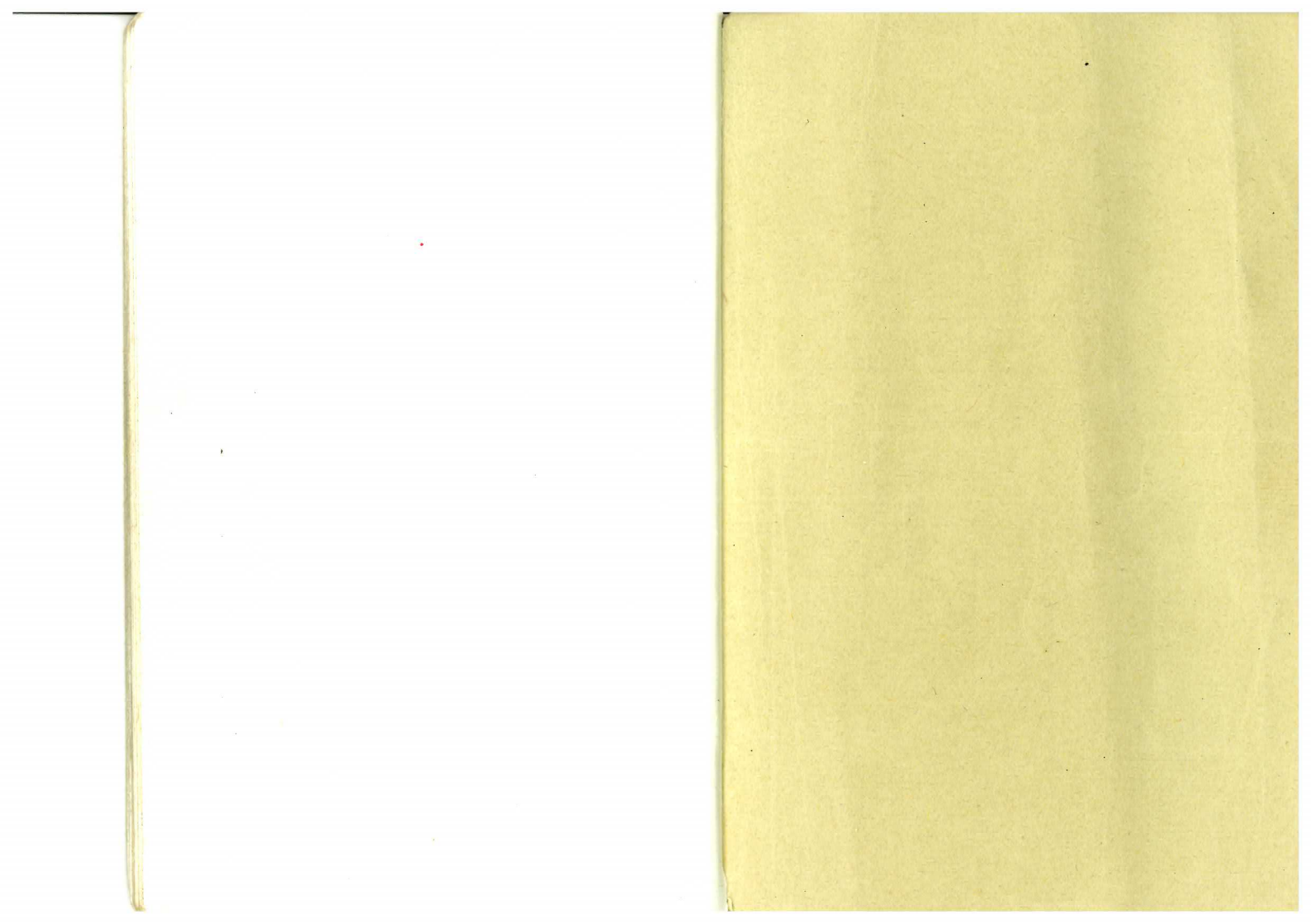



Sym. 7622-4.

5. 4-54.

Engelsk.

Printed in Sweden.

STROKIRKS BOKINDUSTRI A.-B., SKÖVDE

Free Manuals Download Website

<http://myh66.com>

<http://usermanuals.us>

<http://www.somanuals.com>

<http://www.4manuals.cc>

<http://www.manual-lib.com>

<http://www.404manual.com>

<http://www.luxmanual.com>

<http://aubethermostatmanual.com>

Golf course search by state

<http://golfingnear.com>

Email search by domain

<http://emailbydomain.com>

Auto manuals search

<http://auto.somanuals.com>

TV manuals search

<http://tv.somanuals.com>