

Model #HDC302000



USE AND CARE GUIDE

30-GALLON STATIONARY AIR COMPRESSOR

Questions, problems, missing parts?
Before returning to the store, call
Husky Customer Service
8 a.m. - 7 p.m., EST, Monday - Friday
9 a.m. - 6 p.m., EST, Saturday

1-888-HD-HUSKY

HUSKYTOOLS.COM

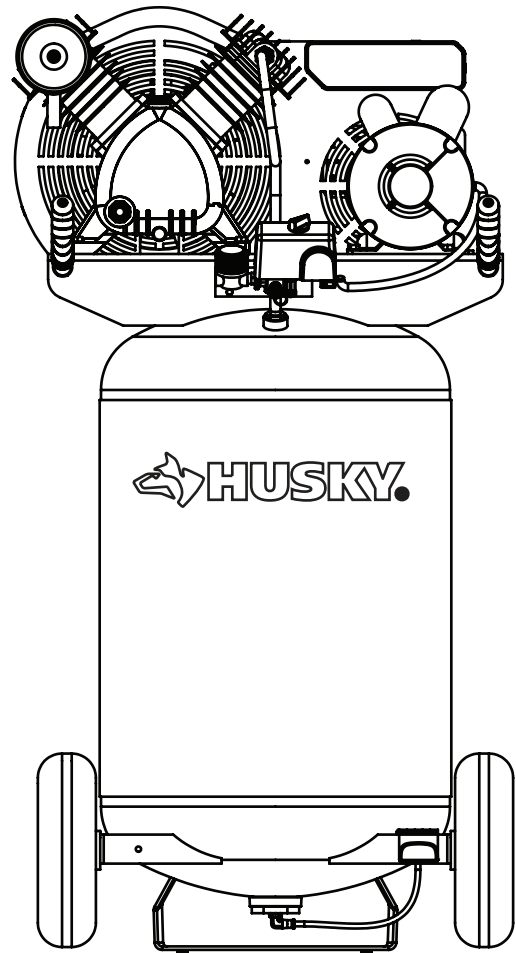

THANK YOU

We appreciate the trust and confidence you have placed in Husky through the purchase of this air compressor. We strive to continually create quality products designed to enhance your home. Visit us online to see our full line of products available for your home improvement needs. Thank you for choosing Husky!

Table of Contents

Safety Information 2
 California Proposition 65 2
 General Safety 3
 Work Area Safety 4
 Personal Safety 5
 Electrical Safety 5
 Spraying Precautions 5
Warranty 6
Pre-Installation 7
 Tools Required 7
 Hardware Required 7
 Package Contents 8
 Specifications 9
 Compressor Components 10



Pre-Assembly 12
Assembly 13
Pre-Operation - Electrical 14
Operation 15
Maintenance 17
Care and Cleaning 19
Troubleshooting 22
Service Parts 24

Safety Information

This manual contains information that is very important to know and understand. This information relates to protecting YOUR SAFETY and PREVENTING EQUIPMENT PROBLEMS. To help you recognize this information, we use the symbols below. Please read the manual and pay attention to these symbols.

	DANGER: Indicates an imminently hazardous situation which, if not avoided, WILL result in death or serious injury .
	WARNING: Indicates a potentially hazardous situation which, if not avoided, COULD result in death or serious injury .
	CAUTION: Indicates a potentially hazardous situation which, if not avoided, MAY result in minor or moderate injury .
	IMPORTANT: Indicates important information, that if not followed, MAY cause damage to equipment.
	NOTE: Information that requires special attention.

CALIFORNIA PROPOSITION 65

	WARNING: This product can expose you to chemicals, including lead, which are known to the state of California to cause cancer and birth defects or other reproductive harm. For more information go to www.P65Warnings.ca.gov
 	WARNING: Wear eye and mask protection. You can create dust when you cut, sand, drill or grind materials such as wood, paint, metal, concrete, cement, or other masonry. This dust often contains chemicals known to cause cancer, birth defects, or other reproductive harm. Wear protective gear.

GENERAL SAFETY

	DANGER: Breathable Air Warning: This compressor/pump is NOT equipped and should NOT be used “as is” to supply breathing quality air. For any application of air for human consumption, you must fit the air compressor/pump with suitable in-line safety and alarm equipment. This additional equipment is necessary to properly filter and purify the air to meet minimal specifications for Grade D breathing as described in Compressed Gas Association Commodity Specification G 7.1, OSHA 29 CFR 1910.134, and/or the Canadian Standards Associations (CSA).
Disclaimer of Warranties: In the event the compressor is used for the purpose of breathing air application and proper in-line safety and alarm equipment is not simultaneously used, existing warranties are void, and the Manufacturer disclaims and liability whatsoever for any loss, personal injury, or damage.	

Safety Information (continued)

GENERAL SAFETY

- Read all manuals included with this product carefully. Be thoroughly familiar with the controls and the proper use of the equipment.
- Only persons well acquainted with these rules of safe operation should be allowed to use the compressor.
- Tanks rust from moisture build-up, which weakens the tank. Make sure to drain the tank regularly and inspect periodically for unsafe conditions, such as rust formation and corrosion.
- Fast moving air will stir up dust and debris which may be harmful. Release air slowly when draining moisture or depressurizing the compressor system.

WORK SAFETY AREA

- Keep visitors away from the compressor, and NEVER allow children in the work area.
- Before each use, inspect the compressed air system and electrical components for signs of damage, deterioration, weakness, or leakage. Repair or replace defective items before using.
- Check all fasteners at frequent intervals for proper tightness.
- If the equipment should start to vibrate abnormally, STOP the engine/motor and check immediately for the cause. Vibration is generally a warning of trouble.
- To reduce fire hazard, keep the engine/motor exterior free of oil, solvent, or excessive grease.
- Never attempt to adjust the ASME safety valve. Keep the safety valve free from paint and other accumulations.



DANGER: Never attempt to repair or modify a tank! Welding, drilling, or any other modification will weaken the tank, resulting in damage from rupture or explosion. Always replace worn, cracked, or damaged tanks.



CAUTION: See the compressor specification decal for maximum operating pressure. Do not operate with pressure switch or pilot valves set higher than the maximum operating pressure.



IMPORTANT: Drain liquid from the tank daily.



NOTE: The **DANGER, WARNING, CAUTION, IMPORTANT** and **NOTE** notifications and instructions in this manual cannot cover all possible conditions and situations that may occur. It must be understood by the operator that caution is a factor which cannot be built into this product, but must be supplied by the operator.



WARNING: Motors, electrical equipment, and controls can cause electrical arcs that will ignite a flammable gas or vapor. Never operate or repair in or near a flammable gas or vapor. Never store flammable liquids or gases in the vicinity of the compressor.



WARNING: An ASME code safety relief valve with a setting no higher than the maximum allowable working pressure (MAWP) MUST be installed in the tank for this compressor. The ASME safety valve must have sufficient flow and pressure ratings to protect the pressurized components from bursting.



WARNING: Never use plastic (PVC) pipe for compressed air. Serious injury or death could result.



WARNING: This compressor is extremely top heavy. The unit must be bolted to the floor with isolation pads before operating to prevent equipment damage, injury, or death.



WARNING: Do not modify this compressor. Do not use or create accessories not recommended for use with this compressor. Alterations and/or modifications are a form of misuse, which could result in a hazardous condition leading to possible personal injury or equipment damage.



CAUTION: Do not use this compressor in an environment where the air is contaminated or dusty. Using the compressor in such an environment may cause equipment damage.

Safety Information (continued)

PERSONAL SAFETY



- Wear safety glasses and use hearing protection when operating the unit.
- Do not stand on or use the unit as a hand hold.
- Do not wear loose clothing or jewelry that will get caught in the moving parts of the unit.
- Keep fingers away from a running compressor; fast moving and hot parts will cause injury and/or burns. Compressor parts may be hot even if the unit is stopped.



WARNING: Never operate the compressor without a beltguard. This unit can start automatically without warning. Personal injury or property damage could occur from contact with moving parts.



CAUTION: Compressor parts may be hot even if the unit is stopped.

ELECTRICAL SAFETY



- Follow all local electrical and safety codes as well as in the United States, the National Electrical Codes (NEC), and Occupational Safety and Health Act (OSHA).
- Avoid body contact with grounded surfaces such as pipes, radiators, ranges, and refrigerators. There is an increased risk of electric shock if your body is grounded.
- Do not expose power equipment to rain or wet conditions. Water entering the power equipment will increase the risk of electric shock.
- Replace damaged cords/wiring immediately. Damaged cords/wiring increase the risk of electric shock.



WARNING: Improper electrical grounding can result in electrical shock. The wiring should be done by a qualified electrician.



CAUTION: Improper electrical installation of this product may void its warranty. Have circuit wiring performed by qualified personnel, such as a licensed electrician who is familiar with the current national and local electrical codes.

SPRAYING PRECAUTIONS



- Do not smoke when spraying paint, insecticides, or other flammable substances.
- Use a face mask/respirator when spraying and spray in a well ventilated area to prevent health and fire hazards.
- Do not direct paint or other sprayed material at the compressor. Locate the compressor as far away from the spraying area as possible to minimize overspray accumulation on the compressor.
- When spraying or cleaning with solvents or toxic chemicals, follow the instructions provided by the chemical manufacturer.



WARNING: Do not spray flammable materials in the vicinity of an open flame or near ignition sources including the compressor unit.

Warranty

LIMITED TWO-YEAR WARRANTY

WHAT IS COVERED

From the date of purchase, parts and labor are covered to remedy substantial defects due to material and workmanship during the first year of ownership with the exceptions noted below. From the date of purchase, parts only are covered to remedy substantial defects due to material and workmanship during the second year of coverage with exceptions noted below.

This warranty applies only to the original retail purchaser and may not be transferred. If the compressor is used for commercial, industrial, or rental purposes, the warranty will apply for ninety (90) days from the date of purchase. Two-stage compressors are not limited to a ninety (90) day warranty when used in commercial or industrial applications. Some states do not allow limitations on how long an implied warranty lasts, so the above limitations may not apply to you.

WARRANTOR: Campbell Hausfeld a Marmon/Berkshire Hathaway Company, 225 Pictoria Drive, Suite 210, Cincinnati, Ohio, 45246.

The responsibilities of the warrantor under this warranty is to repair or replace, at the warrantor's option, this compressor or components which are defective, have malfunctioned, and/or have failed to conform within the duration of the specific warranty period. Repair or replacement will be scheduled and serviced according to the normal work-flow at the servicing location and will depend on the availability of replacement parts.

The responsibilities of the purchaser under this warranty are as follows: a) provide dated proof of purchase and maintenance records; b) call to obtain your warranty service options (freight costs must be borne by the purchaser); c) use reasonable care in the operation and maintenance of the products as described in the owner's manual(s); d) repairs requiring overtime, weekend rates, or anything beyond the standard manufacturer warranty repair labor reimbursement rate; e) time required for any security checks, safety training, or similar for service personnel to gain access to facility; and f) location of unit must have adequate clearance for service personnel to perform repairs and be easily accessible.

WHAT IS NOT COVERED

This warranty does not cover normal wear and tear or any malfunction, failure, or defect resulting from misuse, abuse, neglect, alteration, modification, or repair by other than a service center authorized by the manufacturer to repair this air compressor. Expendable materials, such as motor brushes, seals, etc., are not covered by this warranty. This warranty does not apply to this compressor used in industrial applications or for rental purposes. Husky makes no warranties, representations, or promises as to the quality or performance of its air compressors other than those specifically stated in this warranty.

Implied warranties, including those of merchantability and fitness for a particular purpose, are limited to two years from the date of original purchase by the consumer. Any incidental, indirect, or consequential loss, damage, or expense that may result from any defect, failure, or malfunction of the manufacturer's product is not covered by this warranty. Some states do not allow the exclusion or limitations of incidental or consequential damages, so the above limitation or exclusion may not apply to you. The warranty does not cover any failure that results from an accident, purchaser's abuse, neglect, or failure to operate products in accordance with instructions provided in the owner's manual(s) supplied with compressor.

This warranty does not cover pre-delivery service, i.e. assembly, oil or lubricants, and adjustment. This warranty does not cover items or service that is normally required to maintain the product, i.e. lubricants, filters, gaskets, etc.

Gasoline engines and components are expressly excluded from coverage under this limited warranty. The purchaser must comply with the warranty given by the engine manufacturer which is supplied with the product.

The following items are not covered under this warranty. This warranty excludes these items (pertaining to all compressors) as follows: a) any component damaged in shipment or any failure caused by installing or operating unit under conditions not in accordance with installation and operation guidelines or damaged by contact with tools or surroundings; b) pump or valve failure caused by rain, excessive humidity, corrosive environments, or other contaminants; c) cosmetic defects that do not interfere with compressor functionality; d) rusted tanks, including but not limited to rust due to improper drainage or corrosive environments; e) any components that are considered normal wear items and are not covered after the first year of ownership (the electric motor, check valve, pressure switch, regulator, pressure gauges, hose, tubing, pipe, fittings and couplers, screws, nuts, hardware items, belts, pulleys, flywheel, air filter and housing, gaskets, seals, oil leaks, air leaks, oil consumption or usage, piston rings); f) the tank drain valves; g) damage due to incorrect voltage or improper wiring; h) other items not listed but considered general wear parts; i) pressure switches, air governors, load/unload devices, throttle control devices, and safety valves modified from factory settings; j) damage from inadequate filter maintenance; and k) induction motors operated with electricity produced by a generator.

The following items are not covered under this warranty. This warranty excludes these items (specific to lubricated compressors) as follows: a) pump wear or valve damage caused by using oil not specified; b) pump wear or damage caused by any oil contamination; and c) pump wear or damage caused by failure to follow proper oil maintenance guidelines, operation below proper oil level, or operation without oil.

Labor, service calls, or transportation charges after the first year of ownership are not covered on stationary air compressors. Stationary air compressors are defined as those units not including a handle or wheels.

This Limited Warranty applies in the U.S., Canada, and Mexico only. This warranty gives you specific legal rights, and you may also have other rights which vary from state to state.

How to get service: Call 1-888-43-HUSKY or visit www.HUSKYTOOLS.com.

Pre-Installation

PLANNING INSTALLATION

It is extremely important to use the compressor in a clean, well ventilated area where the surrounding air temperature will not be more than 100°F. Provide a minimum clearance of 18 in. between the compressor flywheel or fan and the wall, and ensure clear access to the drain valve to facilitate condensate drainage. Do not locate the compressor air inlet near steam, paint spray, sandblast areas, or any other source of contamination.

 **IMPORTANT:** This compressor is not intended for outdoor installation.

TOOLS REQUIRED

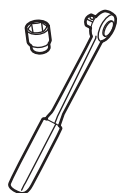

Ratchet and
1/2 in. Socket
9/16 in. Socket



Safety Goggles



Work Gloves



Adjustable
Wrench

HARDWARE INCLUDED

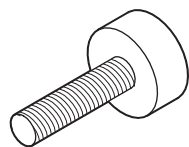

AA

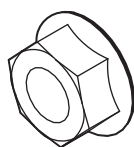

BB

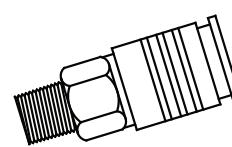

CC

Part	Description	Quantity
AA	Isolater Foot bolt	2
BB	Locknut - 5/16 - 18 Spinlock Nut Bolt	2
CC	Coupler - 1/4 in. I/M Steel Coupler	1

 **NOTE:** Hardware not shown to actual size.

Pre-Installation

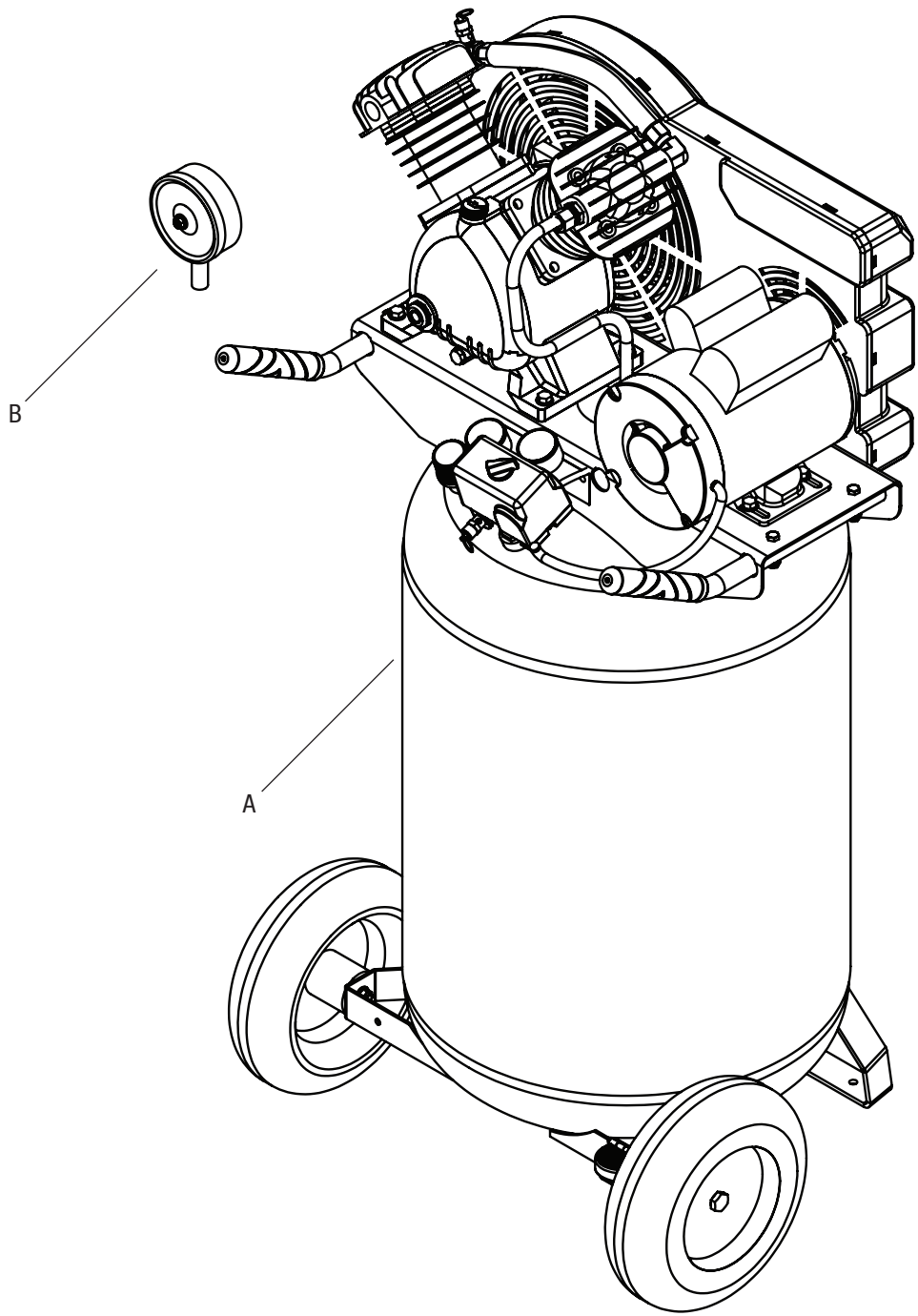

Part	Description	Quantity
A	Air Compressor Unit	1
B	Air Filter Assembly	1

Pre-Installation

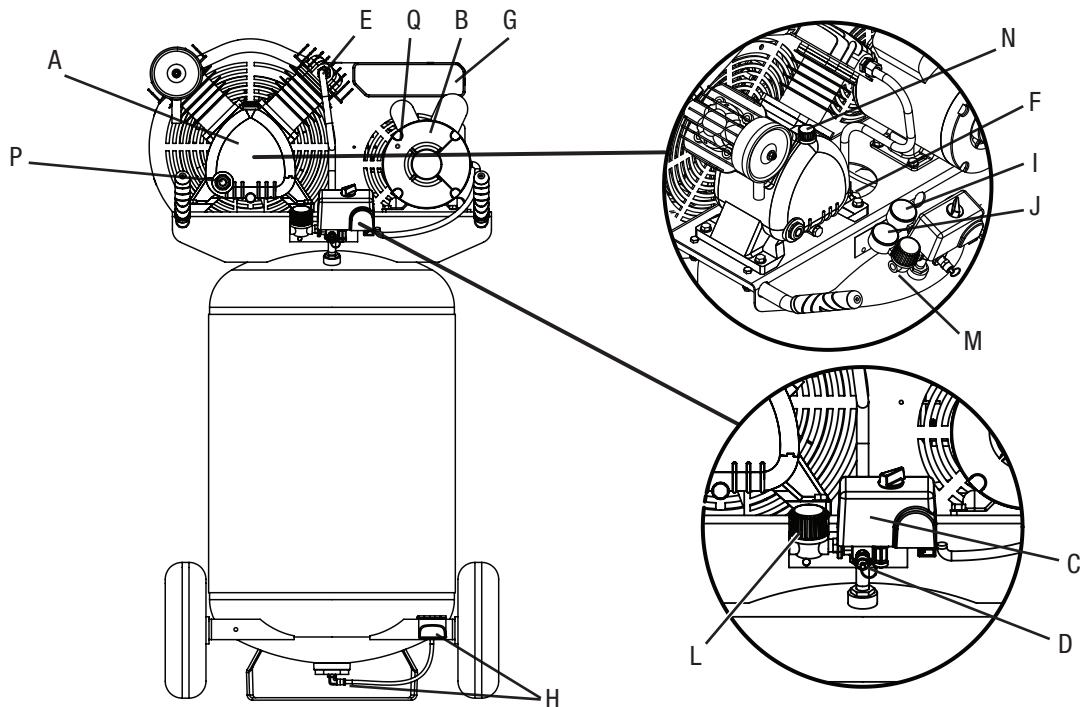

Part	Description
A	Pump - 2-stage compressor efficiently generates compressed air.
B	Motor - Electric induction drive that provides the power to spin the pump.
C	Pressure Switch (AUTO/OFF Switch) - In the AUTO position, the compressor shuts off automatically when the tank pressure reaches the maximum preset pressure. After air is used from the tank and drops to a preset low level, the pressure switch automatically turns the motor back on. In the OFF position, the compressor will not operate. This switch should be in the OFF position when connecting or disconnecting the power from the unit. When the pressure switch turns the motor off you will hear air leaking out of the pressure switch unloader valve for a short time. This releases the air pressure from the discharge tube and allows the compressor to restart easier.
D	ASME Safety Valve - This valve automatically releases air if the tank pressure exceeds the preset maximum.
E	Discharge Tube - This tube carries compressed air from the pump to the check valve. This tube becomes very hot during use. To avoid the risk of severe burns, never touch the discharge tube.
F	Check Valve - One-way valve that allows air to enter the tank, but prevents air in the tank from flowing back into the compressor pump.
G	Belt Guard - Covers the belt, motor pulley, and flywheel.
H	Drain Valve - Use this valve to drain moisture from the tank daily to reduce the risk of corrosion.
I	Tank Pressure Gauge - Indicates the amount of air pressure stored in the tank.
J	Outlet Pressure Gauge - Indicates the amount of air pressure being delivered out the discharge port.
K	Air Filter - Keeps large particulates out of the air flowing into the compressor.
L	Regulator - Controls the amount of air pressure released at the discharge port.
M	Discharge Port - Air delivery port for transfer of compressed air.
N	Oil Fill - This is where oil is added to the crankcase.
O	Oil Drain - This is where the oil is drained from the crankcase to change the oil.
P	Sight Glass - This is where the oil level is checked.
Q	Motor Thermal Overload - This device protects the motor from overheating by shutting it off if it gets too hot. When the motor is completely cool, the protector can be reset if it has tripped, by pushing the reset button.

Pre-Installation

SPECIFICATIONS

Horsepower (HP)	2.0
Pump Type	2-Stage Oil Lubricated
Voltage	120 Volts, 15 Amps 60 Hz, 1 Phase
Air Delivery @ 175 psi	5.1 CFM
Air Delivery @ 90 psi	5.3 CFM
Air Delivery @ 40 psi	5.6 CFM
Max. Air Pressure	175 psi
Pump-up Time (0-175 psi)	9 Minutes, 30 Seconds
Recovery Time (145-175 psi)	About 75 Seconds

Tank Outlet Size	1/4 in. NPT
Oil Capacity	Approximately 24 ounces
Depth	23 in.
Width	24 in.
Height	46 in.
Shipping Weight	178 lbs

PREPARING FOR INSTALLATION

- Remove box.
- Unbolt the air compressor unit (A) from the shipping skid. Using a ratchet with a 1/2 in. socket.
- Remove the bolts holding the rear leg in place.
- Remove the bolt holding the shipping plate (1) in place at the front of the air compressor unit (A).
- Remove the air compressor unit (A) from the skid. This may require at least two people - one person to carefully roll the unit off the skid and one to help maintain balance so the unit does not topple.
- While firmly holding both handles slowly tilt compressor toward you. Once the compressor is fully off the skid, carefully place the unit on the ground taking caution to not scrape or mark the floor.

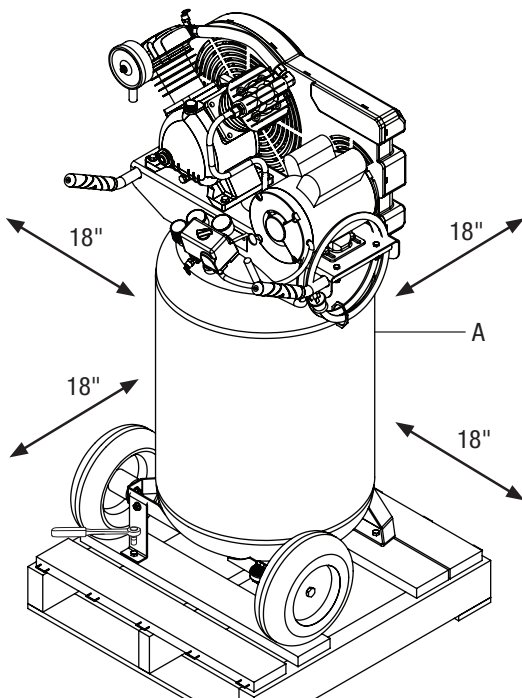

WARNING: Disconnect, tag, and lock out power source, and then release all pressure from the system before attempting to install, service, relocate, or perform any maintenance.

WARNING: This compressor is extremely top heavy. Enlist additional help to remove it from the shipping skid.

CAUTION: Never use the shipping skid for mounting the compressor.

IMPORTANT: Provide a minimum clearance of 18 in. between the compressor flywheel or fan and the wall, and ensure clear access to the drain valve to facilitate condensate drainage.

IMPORTANT: It is extremely important to install the compressor in a clean, well ventilated area where the surrounding air temperature will not be more than 100 °F.

IMPORTANT: Do not locate the compressor air inlet near steam, paint spray, sandblast areas, or any other source of contamination.

IMPORTANT: This compressor is not intended for outdoor installation.

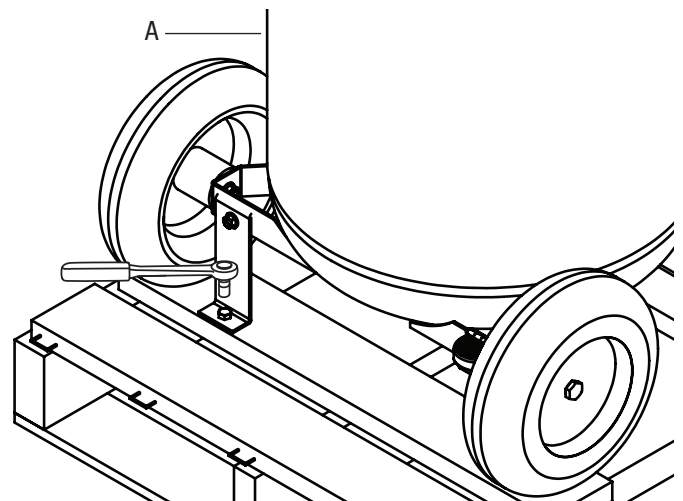

Assembly

1 Installing the foot bolts

- Have one person tilt the air compressor unit (A) forward slightly to allow access to the foot bar. Secure the air compressor unit (A) properly to ensure the air compressor unit (A) does not tip over or fall forward on the person installing the foot bolts.
- Insert the foot bolt (AA) through the foot bar (1). The foot bolt pad should be on the lower side of the foot bar.
- Use the ratchet and 9/16 in. socket to tightly secure the locknut (BB). Repeat with the other foot (AA).

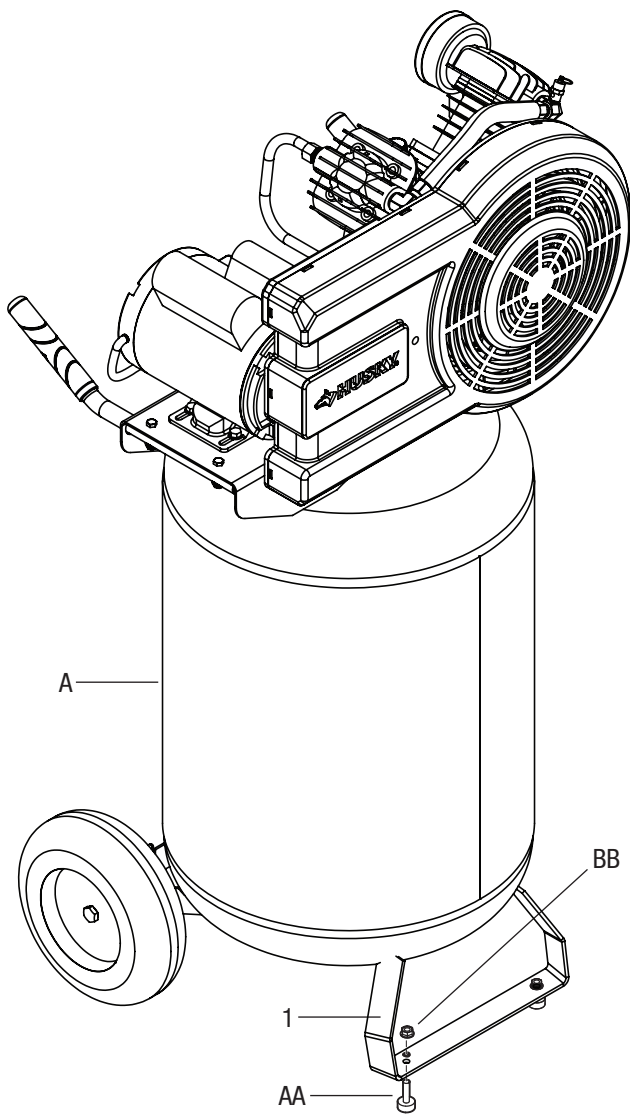

2 Installing the air filter

- Screw the air filter (B) onto the pump air intake.



NOTE: Do not overtighten the filter. Over the life of the unit, you will clean or replace the filter as needed.

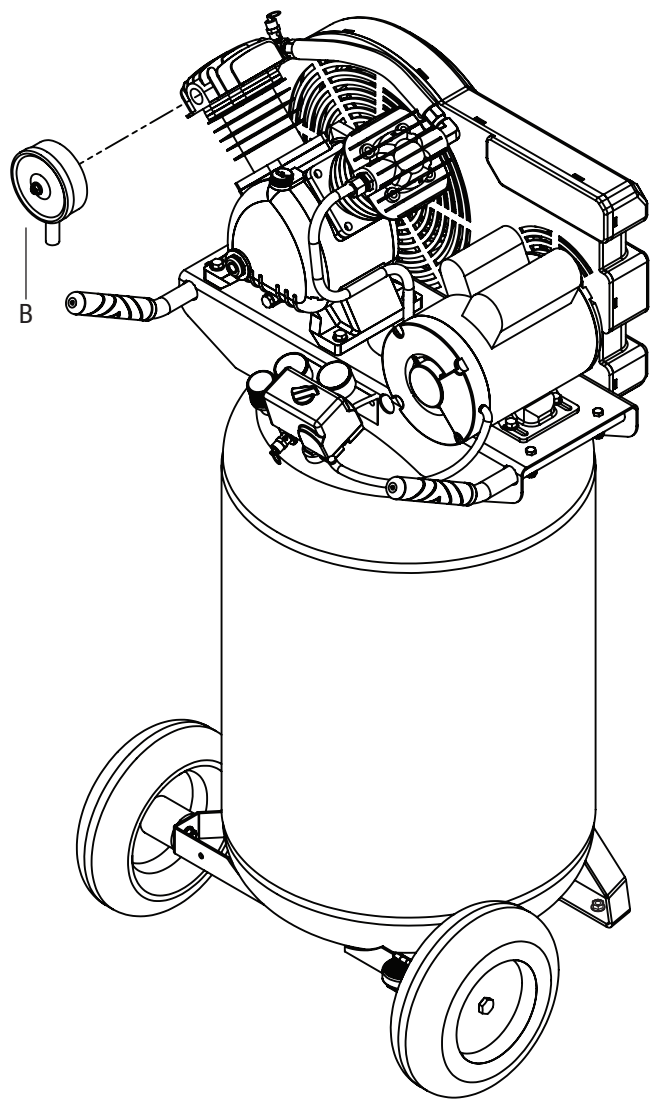

Pre-Operation - Electrical Requirements

1 Preparing for use

Local electrical wiring codes differ from area to area. Source wiring and protector must be rated for at least the amperage and voltage indicated on the motor nameplate, and meet all electrical codes for this minimum. The minimum wire size should also meet all electrical codes.

Make sure that the outlet being used is connected to a slow blow fuse type T or a 120V/20 amp circuit breaker (1).

This product must be grounded. This product is equipped with a cord having a grounding wire with an appropriate grounding plug(2).

Check with a qualified electrician or serviceman when the grounding instructions are not completely understood, or when in doubt as to whether the product is properly grounded. Do not modify the plug provided; if it does not fit the outlet, have the proper outlet installed by a qualified electrician. plug the cord into a properly sized, grounded outlet - 120V, 15 amp (3).

In the event of an electrical short circuit, grounding reduces the risk of electric shock by providing an escape wire for the electric current. The plug must be plugged into an outlet that is properly installed and grounded in accordance with all local codes and ordinances.

Although extension cord is not recommended, if you must use only a 3 wire extension cord that has a 3 blade grounding plug and a 3 slot receptacle that accepts the plug on the product. When using an extension cord be sure to use one heavy enough to carry the current the product draws.

The distance of the outlet from the electrical box must also be considered. Outlets being used must be wired under the following specifications: the outlet's wiring must be 14 AWG for a distance up to 40 ft. long or must be 12 AWG for a distance up to 70 ft. long.

If the above conditions cannot be met or if nuisance tripping of the current protection device occurs, it may not be possible to operate the compressor from a 120 volt 20 amp circuit (4).

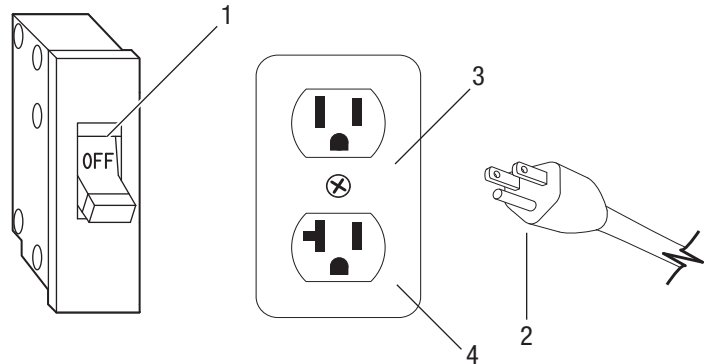

Amp Rating Range	Voltage									
	120V	25 ft	50 ft	100 ft	150 ft	200 ft	250 ft	300 ft	400 ft	500 ft
14-16 AMP	16 AWG	12 AWG	10 AWG	8 AWG	6 AWG	6 AWG	4 AWG	4 AWG	4 AWG	2 AWG



DANGER: Improperly grounded motors are shock hazards. Make sure all the equipment is properly grounded.



WARNING: All wiring and electrical connections must be performed by a qualified electrician familiar with industrial motor controls. Installation must be in accordance with local and national codes.



WARNING: Disconnect, tag, and lock out the power source, and then release all pressure from the system before attempting to install, service, relocate, or perform any maintenance.



WARNING: Overheating, short circuiting, and fire damage will result from inadequate wiring.



IMPORTANT: Damage to the motor from improper electrical voltage or connection will void the warranty.



WARNING: Improper installation of the grounding plug is able to result in a risk of electric shock. When repair or replacement of the cord or plug is required, do not connect the grounding wire to either flat blade terminal. The wire with insulation having an outer surface that is green with or without yellow stripes is the grounding wire. This product is for use on a nominal 120V circuit and has a grounding plug similar to the plug illustrated in sketch A in Figure 69.1. Only connect the product to an outlet having the same configuration as the plug. Do not use an adapter with this product.

Operation

1 Preparing for use

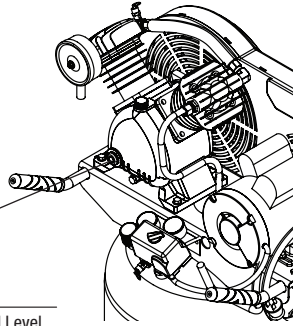
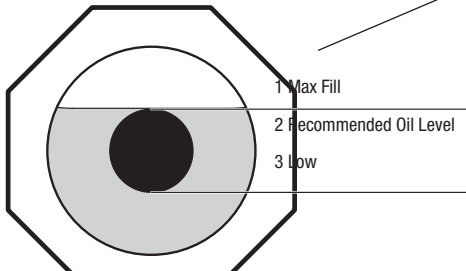

- Use the sight glass on the pump to determine the oil level.
- Add oil to the pump if the oil level is low (3).



CAUTION: Check for proper oil level before operating!



NOTE: The pump oil level is max oil level (1), and the middle of circle is recommended oil level (2).



NOTE: Use SAE 30 industrial grade full synthetic motor oil like Mobil 1® 10W30.



NOTE: Do not exceed the maximum oil capacity of approximately 24 ounces.



NOTE: Do not use regular automotive oil. Additives in regular motor oil can cause valve deposits and reduce pump life.



NOTE: For maximum pump life, drain and replace oil after the first 50 hours of run time.

2 Starting up and breaking in the compressor

- Before the first use it is important to break your compressor in to maximize its performance and life.
- Plug the air compressor unit (A) into an appropriate electrical outlet.
- Open the regulator valve fully.
- The tank will not readily build up any pressure once turned on because the coupler is not installed.
- Moving the pressure switch (1) to the AUTO position to run the air compressor unit (A).
- Run the air compressor unit (A) for thirty (30) minutes at zero (0) psi (under no load) to break in the pump parts.
- After 30 minutes move the pressure switch (1) to the OFF position, and turn the regulator valve to shut off air flow. Install the coupler into the 1/4" NPT threads on the regulator. The air compressor unit (A) is now ready for use.

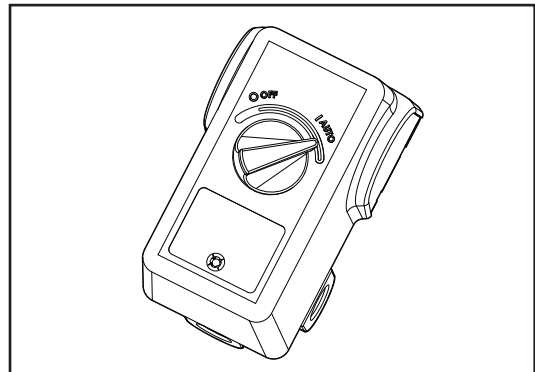
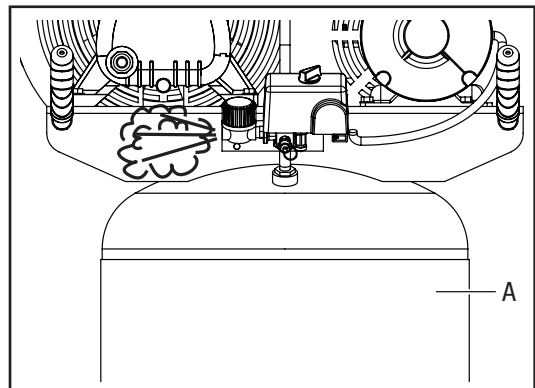

WARNING: Do not attach air tools to the open end of the hose until start-up is completed and the unit checks okay.



WARNING: Never disconnect threaded joints with pressure in the tank!

Operation

ON/OFF CYCLING OF THE COMPRESSOR

The air compressor unit (A) is designed to cycle on and off. With the pressure switch knob in the AUTO position, the compressor pumps air into the tank. When the shut-off (preset “cut-out”) pressure is reached, the compressor automatically shuts off.

If the compressor is left in the AUTO position and air is depleted from the tank by use of a tire chuck, tool, etc., the compressor will restart automatically at its preset “cut-in” pressure. When a tool is in use, the compressor will cycle on and off automatically as needed to maintain air pressure in the tank.

MOISTURE IN COMPRESSED AIR

Moisture in compressed air will form into droplets as it comes from an air compressor pump. When humidity is high or when a compressor is in continuous use for an extended period of time, this moisture will collect in the tank. When using a paint spray or sandblast gun, this water will be carried from the tank through the hose, and out of the gun as droplets mixed with the spray material.

Follow the tank draining instructions in the Maintenance section of this manual.



WARNING: Drain the tank every day to prevent corrosion and possible injury due to tank damage.

For optimal performance of the manual tank drain, the tank pressure should be between 40-50 psi. Do not operate the manual drain with more than 40 psi in the tank or the drain valve may be damaged. Drain the tank of moisture daily using the manual drain valve or by installing the electric drain at the bottom of the tank.



IMPORTANT: This condensation will cause water spots in a paint job, especially when spraying other than water based paints. If sandblasting, it will cause the sand to cake and clog the gun, rendering it ineffective. A filter in the air line, located as near to the gun as possible, will help eliminate this moisture.



IMPORTANT: Drain liquid from the tank daily.

Maintenance

All repairs should be performed by an authorized service representative.

1 Checking and changing the oil

Maintain proper oil level by checking the oil sight glass (1) daily. Change the oil in the pump every 3 months. Use the following procedure to change (or add) oil. Remove the oil drain plug from the base of the pump and install the oil drain extension. Some models include an oil drain extension and cap (found with the owner's manual). Install the oil drain extension and cap before adding oil to the pump. To avoid oil leaks, apply pipe thread sealant or thread tape to the threads on each end of the oil drain extension. Screw the cap onto one end of the extension. Drain extension part number is ST083800AV and drain extension cap part number is ST150100AV.

- Run the compressor for ten minutes to warm up the oil if the unit has not been in use for an extended period of time.
- Turn the compressor off and disconnect the compressor from the power source.
- Position a pan under the pump drain plug (2) to catch the oil.
- Remove the pump drain plug (2) and allow the oil to collect in the pan.
- Reinsert the oil drain plug. Remove the oil fill plug (3) from the pump. Pour new, unused oil into the pump. Do not overfill.
- Reinsert the oil fill plug (3) into position. Return power to the compressor for use.



WARNING: Disconnect, tag, and lock out power source, and then release all pressure from the system before attempting to install, service, relocate, or perform any maintenance.

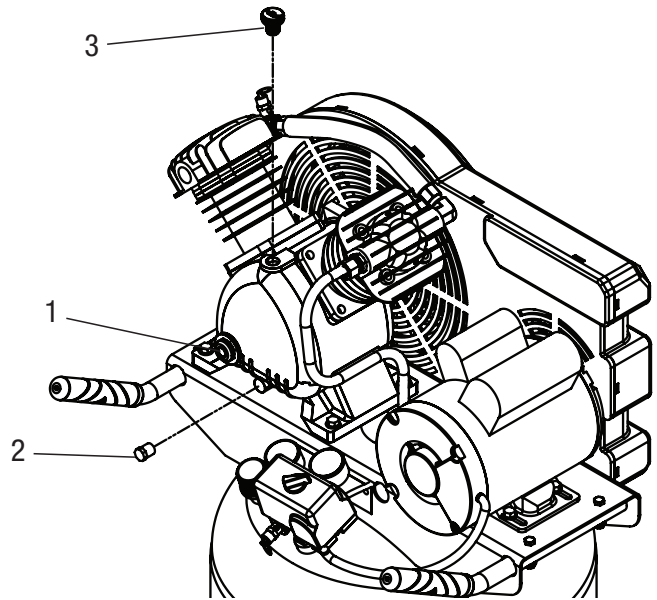

2 Checking the ASME safety valve

- Run the air compressor until it reaches cut-out pressure.
- Turn the compressor off and disconnect the compressor from the power source.
- Put on safety glasses. Protect yourself from fast moving air.
- Pull on the ring of the ASME safety valve (1). This releases pressure from the tank. The safety valve should automatically close at approximately 40 - 50 psi.

If the safety valve does not allow air to be released when you pull on the ring, or if it does not close automatically, it **MUST** be replaced.

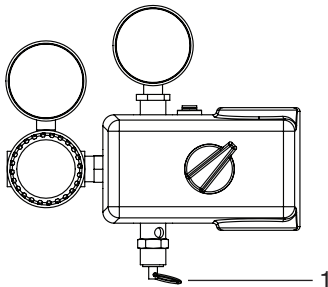

3 Draining the tank of moisture

- Turn the compressor off and disconnect it from the power source.
- Release the pressure from the compressor by pulling on the ASME safety valve. The ASME safety valve should close at approximately 40 - 50 psi.
- Step on the drain pedal (1) on the tank foot bracket. Remaining air pressure will assist in removing moisture from the tank.

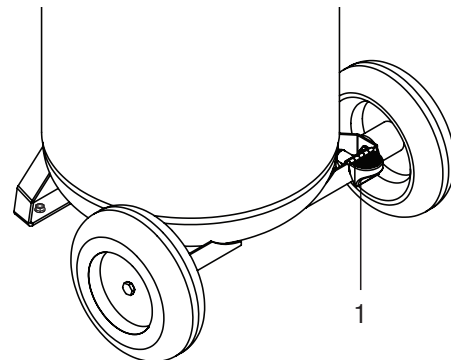

Maintenance (continued)

4 Checking the belt

- Remove the beltguard screw (1).
- Remove the front beltguard (2). The beltguards are held together by pressure snap-latches (3). Wedge a flathead screwdriver between the beltguards at the snap-latches.
- Wedge a screwdriver at the other snap-latch junctions. Twist and separate the snap-latches until the front beltguard comes completely off.
- If the belt appears to be in working order and has no signs of damage, return the front beltguard to the original position and snap it back in place. Tighten the beltguard screw.
- If the belt needs to be replaced, move on to the next step.
- If the belt does not need to be replaced, move to step 6

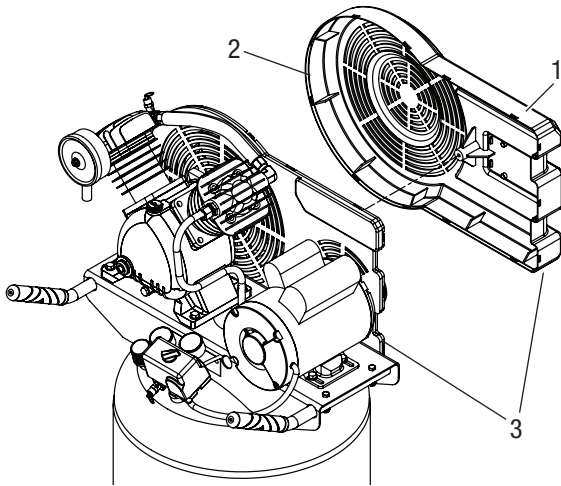

5 Removing the belt

- Loosen (but do not remove) the four bolts (1) holding the motor in place.
- Shift the motor towards the pump. The belt should be slack and easily removable.
- Replace the belt.
- Move the motor back to the original position to create belt tension.
- Tighten the motor bolts.

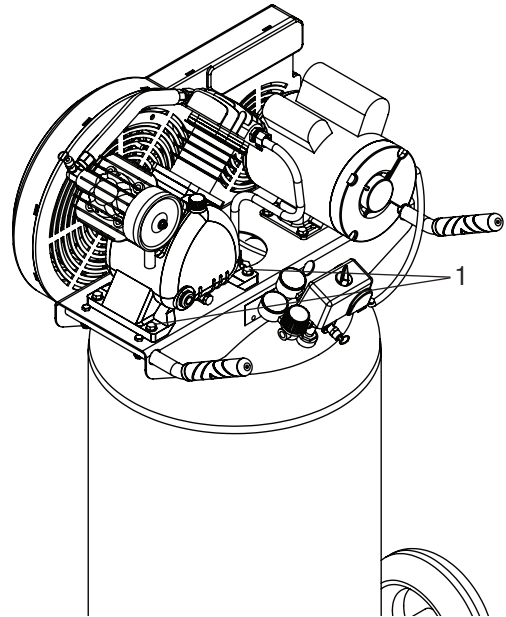

6 Aligning/tensioning the belt

- Lay a straightedge (1) against the face of the flywheel touching the rim at two places (2,3).
- Adjust the flywheel or motor pulley so that the belt (4) runs parallel to the straightedge. Use a gear puller to move the pulley on the motor shaft. Tighten the setscrew after the pulley is positioned.
- Adjust the motor's distance from the pump if needed.
- Belt tension is determined by how much the belt moves when weight is applied. The belt should move no more than 3/8 to 1/2 in. downward if normal thumb pressure is placed on it.
- Tighten the motor bolts once the proper belt tension is achieved.
- Reattach the belt guard.

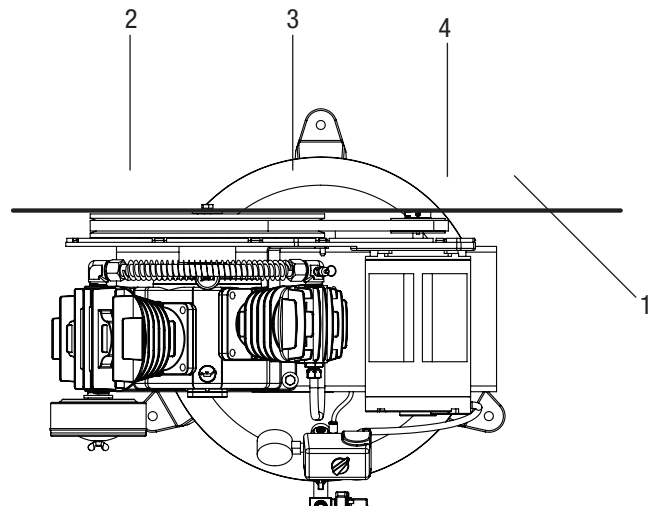

	Bolt Torque
Flywheel	320-350 in. lbs.
Pulley	70-100 in. lbs.

Maintenance (continued)

7 Checking the air filter

- Remove the wing nut (1) and the washer (2).
- Remove the air filter cover (3) from the air filter base (5).
- Remove and inspect the air filter element (4).
- If the air filter element is dirty, replace it. Install a new filter element. If the air filter element is clean, reinstall it.
- Reattach the air filter cover (3).
- Reattach the washer (2) and the wing nut (1). Do not overtighten the wing nut as this maintenance process will be repeated regularly. The wing nut (1) should be snug enough to hold the air filter cover (3) in place.

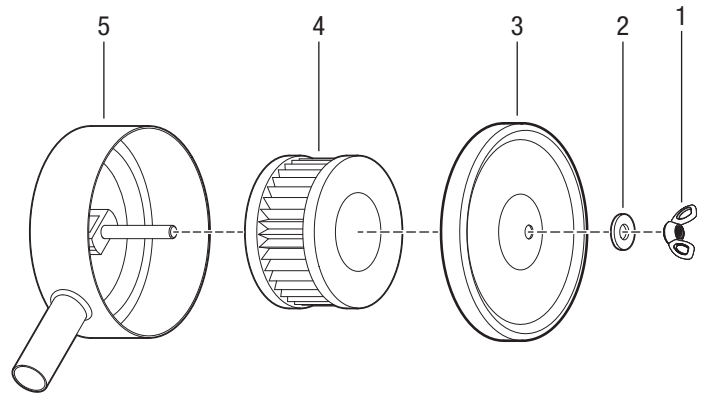

MAINTENANCE SCHEDULE

Operation	Daily	Weekly	Monthly	Every 3 Months
Check Oil Level	X			
Drain Tank	X			
Check Air Filter		X		
Check Safety Valve		X		
Clean Unit			X	
Check Belt Tension			X	
Change Oil				X

Care and Cleaning

- Keep all surfaces clear of debris and dirt.
- Do not attempt to clean the unit while running. Turn off the unit, disconnect it from the mains, and allow the unit to cool down.
- Check the air filter weekly to see if it needs to be cleaned. Remove the filter element. Use hot, soapy water to clean the filter and allow the filter to dry before reinstalling and returning the unit to active duty. Replace a filter that cannot be cleaned.



WARNING: Disconnect, tag, and lock out the power source, and then release all pressure from the system before attempting to install, service, relocate, or perform any maintenance.



IMPORTANT: Change the oil after the first fifty (50) hours of operation. Then perform oil changes every three (3) months.

Troubleshooting

Problem	Possible Cause	Solution
The discharge pressure is low.	<ul style="list-style-type: none"> <input type="checkbox"/> The air demand exceeds the pump capacity. <input type="checkbox"/> The air intake is restricted. <input type="checkbox"/> There are air leaks in the fittings, tubing on the compressor, or the plumbing outside the unit. <input type="checkbox"/> There are blown gaskets. <input type="checkbox"/> There are leaking or damaged valves. 	<ul style="list-style-type: none"> <input type="checkbox"/> Reduce the air demand or use a compressor with more capacity. <input type="checkbox"/> Clean or replace the air filter element. <input type="checkbox"/> Listen for escaping air. Apply soap solution to all fittings and connections. Bubbles will appear at points of leakage. Tighten or replace leaking fittings or connections. Use pipe thread sealant. <input type="checkbox"/> Replace any gaskets proven faulty on inspection. <input type="checkbox"/> Remove the head and inspect for valve breakage, misaligned valves, damaged valve seats, etc. Replace defective parts and reassemble. Install a new head gasket each time the head is removed.
The air compressor unit is making excessive noise (a knocking sound).	<ul style="list-style-type: none"> <input type="checkbox"/> The motor pulley or the flywheel is loose. <input type="checkbox"/> The fasteners on the pump or the motor are loose. <input type="checkbox"/> There is no oil in the crankcase. <input type="checkbox"/> The connecting rod is worn. <input type="checkbox"/> The piston pin bores are worn. <input type="checkbox"/> The piston is hitting the valve plate. <input type="checkbox"/> There is a noisy check valve in the compressor system. 	<ul style="list-style-type: none"> <input type="checkbox"/> Tighten the pulley / flywheel clamp bolts and the setscrews. <input type="checkbox"/> Tighten the fasteners. <input type="checkbox"/> Check for proper oil level; if the oil level is low, check for possible damage to the bearings. Dirty oil can cause excessive wear. <input type="checkbox"/> Replace the connecting rod. Maintain the oil level and change the oil more frequently. <input type="checkbox"/> Remove the piston assemblies from the compressor and inspect for excess wear. Replace the excessively worn piston pin or pistons, as required. Maintain the oil level and change the oil more frequently. <input type="checkbox"/> Remove the compressor head and the valve plate and inspect for carbon deposits or other foreign matter on the top of the piston. Replace the head and the valve plate using the new gasket. See the Lubrication section for the recommended oil type. <input type="checkbox"/> Replace the check valve. Do not disassemble the check valve with air pressure in the tank.
There is a large quantity of oil in the discharge air. In an oil lubricated compressor there will always be a small amount of oil in the air stream.	<ul style="list-style-type: none"> <input type="checkbox"/> The piston rings are worn. <input type="checkbox"/> The compressor's air intake is restricted. <input type="checkbox"/> There is excessive oil in the compressor. <input type="checkbox"/> The oil viscosity is wrong. 	<ul style="list-style-type: none"> <input type="checkbox"/> Replace with new rings. Maintain the oil level and change the oil more frequently. <input type="checkbox"/> Clean or replace the filter. Check for other restrictions in the intake system. <input type="checkbox"/> Drain oil down to the correct full level. <input type="checkbox"/> Only use Mobil 1® 10W-30 or SAE 30 industrial grade compressor oil.
There is water in the discharge air/tank.	<ul style="list-style-type: none"> <input type="checkbox"/> This is normal during operation. The amount of water increases with humid weather. 	<ul style="list-style-type: none"> <input type="checkbox"/> Drain the tank more often. At least daily during use. <input type="checkbox"/> Add a filter to reduce the amount of water in the air line.
The pressure switch does not release air when the unit shuts off.	<ul style="list-style-type: none"> <input type="checkbox"/> The unloader valve on the pressure switch is malfunctioning. <input type="checkbox"/> The hole to the unloader line on the check valve is plugged. 	<ul style="list-style-type: none"> <input type="checkbox"/> Replace the unloader valve if it does not release the pressure for a short period of time when the unit shuts off. Do not disassemble the check valve with air pressure in the tank. <input type="checkbox"/> Check for debris in the unloader line or check the valve that could block air flow. Do not disassemble the exhaust tube or unloader tube with air pressure in the tank.

Troubleshooting (continued)

Problem	Possible Cause	Solution
The motor hums and runs slowly, or the motor does not run at all.	<ul style="list-style-type: none"> <input type="checkbox"/> The voltage is low. <input type="checkbox"/> There are too many devices on same the circuit. <input type="checkbox"/> The electrical connections are loose. <input type="checkbox"/> The pressure switch is malfunctioning - the contacts will not close. <input type="checkbox"/> The check valve is malfunctioning. <input type="checkbox"/> The unloader valve on the pressure switch is defective. <input type="checkbox"/> The motor capacitor(s) are defective. <input type="checkbox"/> The motor is defective. <input type="checkbox"/> Use of an extension cord 	<ul style="list-style-type: none"> <input type="checkbox"/> Check incoming voltage. It should be approximately 120 volts. <input type="checkbox"/> Limit the circuit to the use of the compressor only. <input type="checkbox"/> Check all the electrical connections. <input type="checkbox"/> Replace the pressure switch. <input type="checkbox"/> Replace the check valve. Do not disassemble the check valve with air pressure in the tank. <input type="checkbox"/> Replace the unloader valve. <input type="checkbox"/> Replace the capacitor(s). <input type="checkbox"/> Replace the motor. <input type="checkbox"/> Do not use an extension cord. Use a longer air hose with a larger diameter.
The reset mechanism cuts out repeatedly or the circuit breaker trips repeatedly.	<ul style="list-style-type: none"> <input type="checkbox"/> There is not proper ventilation for the air compressor unit, or the room temperature too high. <input type="checkbox"/> There are too many devices on the same circuit. <input type="checkbox"/> The air intake is restricted. <input type="checkbox"/> The electrical connections are loose. <input type="checkbox"/> The pressure switch shut-off pressure is set too high. <input type="checkbox"/> The check valve is malfunctioning. <input type="checkbox"/> The unloader valve on the pressure switch is defective. <input type="checkbox"/> The motor capacitor(s) are defective. <input type="checkbox"/> The motor is defective. <input type="checkbox"/> Use of an extension cord 	<ul style="list-style-type: none"> <input type="checkbox"/> Move the compressor to a well-ventilated area. <input type="checkbox"/> Limit the circuit to the use of only the air compressor. <input type="checkbox"/> Clean or replace the air filter element. <input type="checkbox"/> Check all the electrical connections. <input type="checkbox"/> Replace the pressure switch. <input type="checkbox"/> Replace the check valve. Do not disassemble the check valve with air pressure in the tank. <input type="checkbox"/> Replace the unloader valve. <input type="checkbox"/> Replace the capacitor(s). <input type="checkbox"/> Replace the motor. <input type="checkbox"/> Do not use an extension cord. Use a longer air hose with a larger diameter.
The tank does not hold pressure when the compressor is off and the shut off valve is closed.	<ul style="list-style-type: none"> <input type="checkbox"/> There are air leaks in the fittings, tubing on the compressor, or the plumbing outside the unit. <input type="checkbox"/> The check valve is worn. <input type="checkbox"/> Check the tank for cracks or pin holes. 	<ul style="list-style-type: none"> <input type="checkbox"/> Listen for escaping air. Apply soap solution to all fittings and connections. Bubbles will appear at points of leakage. Tighten or replace leaking fittings or connections. Use pipe thread sealant. <input type="checkbox"/> Replace the check valve. Do not disassemble the check valve with air pressure in the tank. <input type="checkbox"/> Replace the tank. Never try to repair a damaged tank.
The pressure switch continuously blows air out the unloader valve.	<ul style="list-style-type: none"> <input type="checkbox"/> The check valve is malfunctioning. 	<ul style="list-style-type: none"> <input type="checkbox"/> Replace the check valve if the unloader valve on the pressure switch bleeds off constantly when the unit shuts off. Do not disassemble the check valve with air pressure in the tank.
There is excessive vibration.	<ul style="list-style-type: none"> <input type="checkbox"/> The fasteners on the pump or the motor are loose. <input type="checkbox"/> The belt needs to be replaced. <input type="checkbox"/> The belt needs to be aligned. 	<ul style="list-style-type: none"> <input type="checkbox"/> Tighten the fasteners. <input type="checkbox"/> Replace the belt. Make sure to use the correct size. <input type="checkbox"/> Align the flywheel and the pulley.

Service Parts - Compressor

MODEL HDC302000

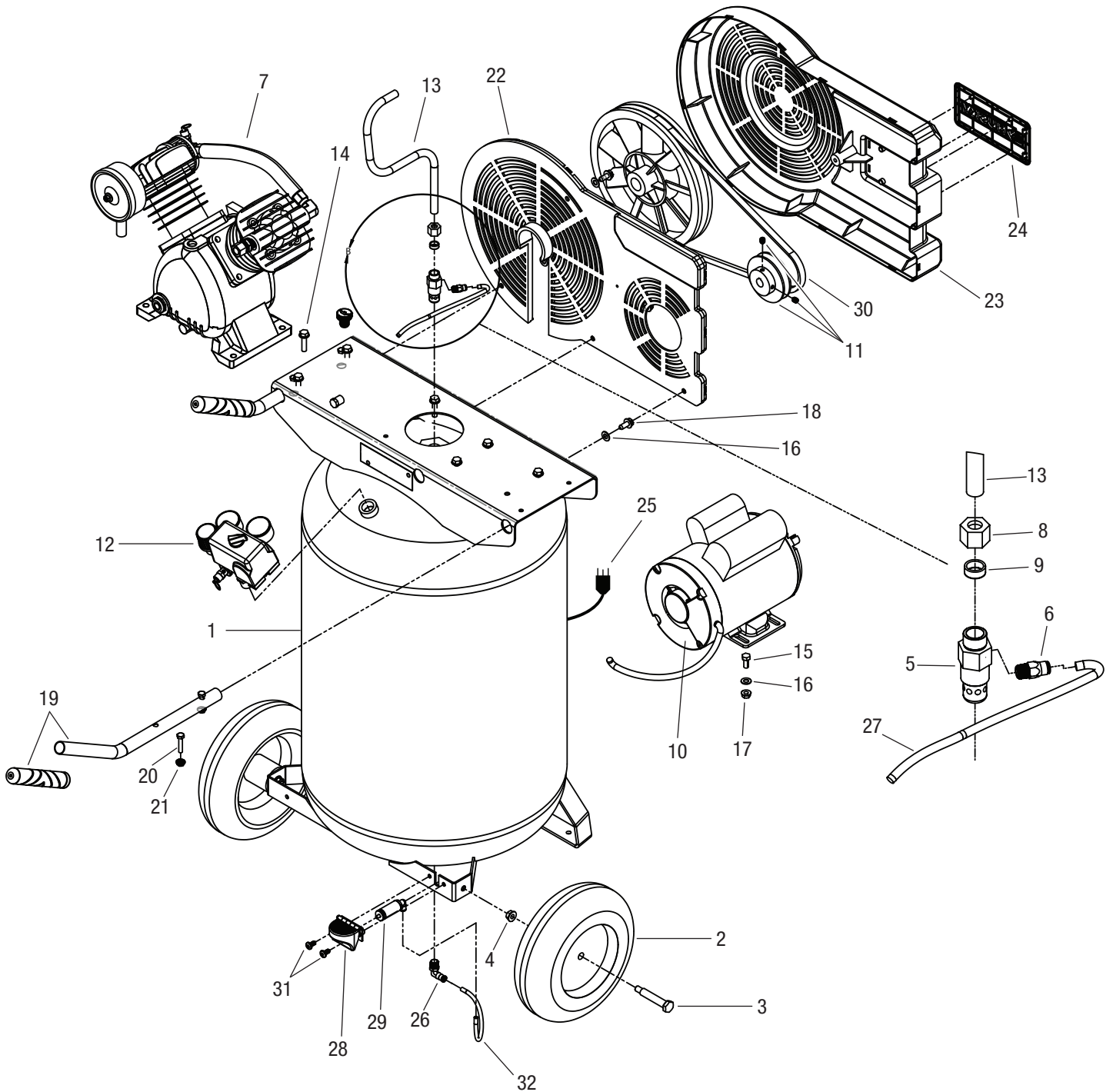

Service Parts - Compressor (continued)

AVAILABLE KITS

WA900000SV

Wheel Kit

Description	Location ID	Qty in Kit
Pneumatic Wheel	2	2
Axle Bolt	3	2
Flange Nut	4	2

XC000800SV

Check Valve Kit

Description	Location ID	Qty in Kit
Check Valve	5	1
Fitting Tube	6	1
Compression Nut	8	1
Ferrule	9	1
Exhaust Tube	13	1
Unloader Tube	27	1

HL570600SV

Handle Kit

Description	Location ID	Qty in Kit
Handle	19	2
1/4 in. Hex Bolt	20	4
1/4 in. Flange Nut	21	4

BG023600SV

Belt Guard Kit

Description	Location ID	Qty in Kit
5/16 in. Flat Washer	16	4
5/16 in. Self Tapping Screw	18	4
Composite Belt Guard (Back)	22	1
Composite Belt Guard (Front)	23	1
Composite Belt Guard (Name Plate)	24	1

D-141000AV

Foot Pedal Drain Kit

Description	Location ID	Qty in Kit
Elbow Push Connect	26	1
Foot Pedal	28	1
Foot Pedal Drain Valve	29	1
1/14 in. Torx Screw	31	1
Drain Tube	32	1

PU019200AV

Replacement Motor Pulley

Description	Location ID	Qty in Kit
Pulley and Set Screws	11	3

AVAILABLE KITS

MY000900SV

Pressure Switch Kit

Description	Location ID	Qty in Kit
Pressure Switch Kit	12	1

BT009500AV

Replacement V-Belt

Description	Location ID	Qty in Kit
Belt	30	1

AR237300CG

Replacement Tank

Description	Location ID	Qty in Kit
Tank	1	1

MC036001IP

Replacement Motor

Description	Location ID	Qty in Kit
Motor	10	1

XC002200IP

Replacement Pump

Description	Location ID	Qty in Kit
Pump	7	1

EC012601AV

Replacement Power Cord

Description	Location ID	Qty in Kit
Power Cord (120V)	25	1

SR060513SV

Manual Drain (Not Pictured)

Description	Location ID	Qty in Kit
Manual Quarter Turn Drain Valve (Optional)	Not Pictured	1

Fastener Sizes:

1/4 in. Pulley, Handle, Drain Valve

5/16 in. Pump, Motor, Belt Guard

3/8 in. Wheel Axle

Service Parts - Pump

MODEL XC002200AV

Items marked with an asterisk (*) are available in kits only.

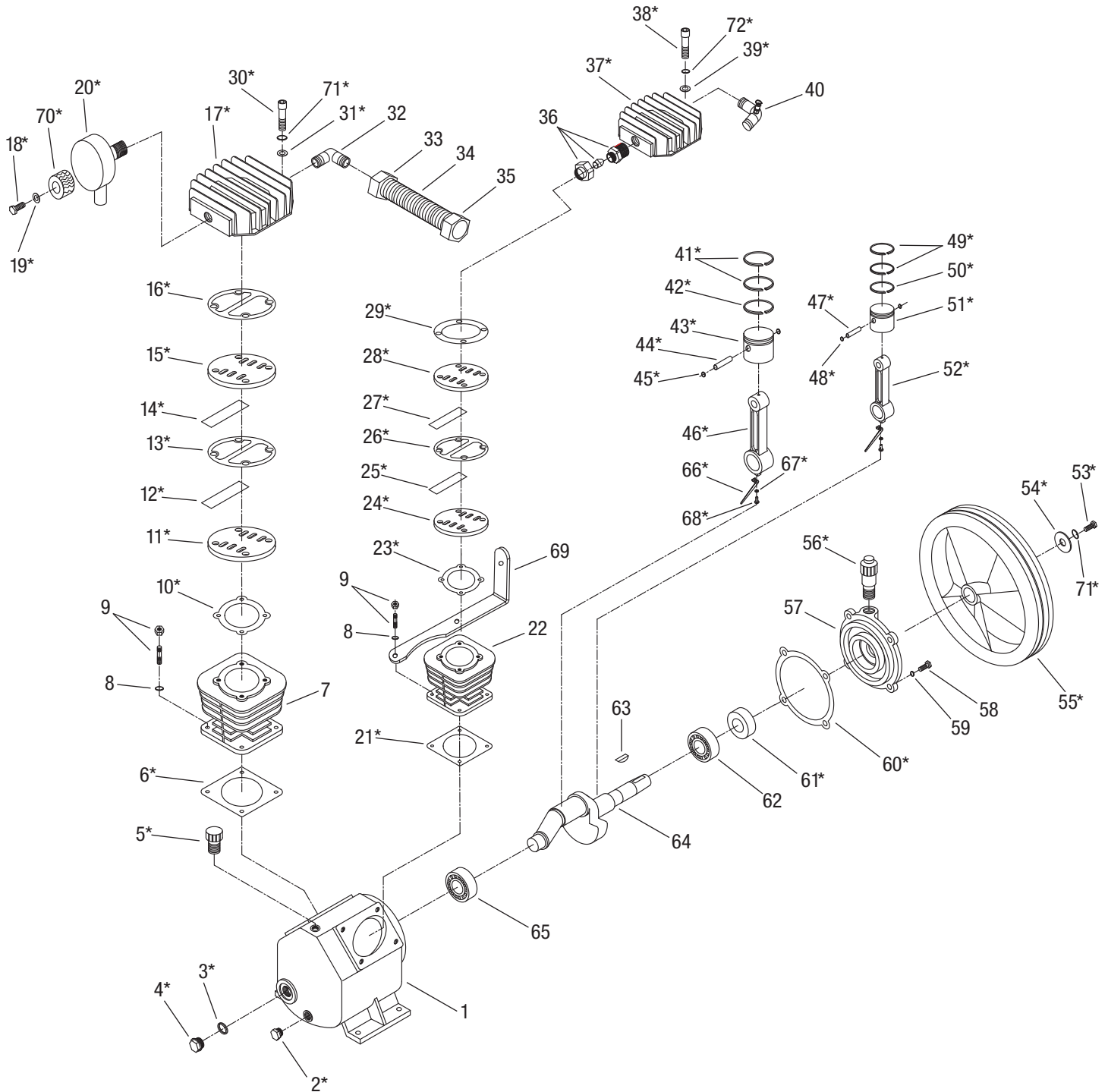

Service Parts - Pump (continued)

AVAILABLE KITS

XC000100AV

Cylinder Head & Fasteners Kit

Description	Location ID	Qty in Kit
Cylinder Head	17, 37	2
Hex Bolt	30, 38	8
Washer	31, 39	8
Spring Washer	71, 72	8

XC000200AV

Valve Plate Assemblies

Description	Location ID	Qty in Kit
Valve Plate	11, 15, 24, 28	4
Valve	12, 14, 25, 27	4

XC000300AV

Ring Replacement Kit

Description	Location ID	Qty in Kit
Compression Rings	41, 49	4
Wiping Ring	42, 50	2

XC000400AV

Piston/Connecting Rod Assembly

Description	Location ID	Qty in Kit
Piston	43, 51	2
Wrist Pin	44, 47	2
Retaining Ring	45, 48	4
Connecting Rod	46, 52	2
Oil Dipper	66	1
Lock Washer	67	1
Screw	68	1

XC000500AV

Gasket Kit

Description	Location ID	Qty in Kit
Sight Glass Gasket	3	1
Cylinder Gasket	6, 21	2
Valve Plate Gasket	10, 23	2
Valve Gasket	13, 26	2
Head Gasket	16, 29	2
Bearing Cap Gasket	60	1
Crankshaft Oil Seal	61	1

AVAILABLE KITS

XC000600AV

Flywheel Kit

Description	Location ID	Qty in Kit
Flywheel Bolt	53	1
Flywheel Washer	54	1
Flywheel	55	1
Crankshaft Key	63	1
Spring Washer	71	1

XC000700AV

Pump Accessory Kit

Description	Location ID	Qty in Kit
Oil Plug	2	1
Sight Glass Gasket	3	1
Sight Glass	4	1
Oil Fill Cap	5	1
Wing Nut	18	1
Washer	19	1
Air Filter Assembly	20	1
Crankcase Breather	56	1

VH901800AV

Air Filter Element

Description	Location ID	Qty in Kit
Air Filter Element	70	1

Available in Belt Guard Kit (Compressor Service Parts)

Belt Guard Bracket	69
--------------------	----

Reference Only - Not Available

Description	Location ID
Crankcase	1
Cylinder	7, 22
Washer	8, 59
Hex Head Cap Screw	9, 58
Elbow	32
Nut	33, 35
Inter Cooler	34
Compression Fitting	36
Elbow with Safety Valve	40
Bearing Cap	57
Ball Bearing	62, 65
Crankshaft	64



Questions, problems, missing parts? Before returning to the store,
call Husky Customer Service
8 a.m.- 7 p.m., EST, Monday-Friday, 9 a.m. - 6 p.m., EST, Saturday

1-888-43-HUSKY

HUSKYTOOLS.COM

Retain this manual for future use.

Document Number IN574600 12/19

Free Manuals Download Website

<http://myh66.com>

<http://usermanuals.us>

<http://www.somanuals.com>

<http://www.4manuals.cc>

<http://www.manual-lib.com>

<http://www.404manual.com>

<http://www.luxmanual.com>

<http://aubethermostatmanual.com>

Golf course search by state

<http://golfingnear.com>

Email search by domain

<http://emailbydomain.com>

Auto manuals search

<http://auto.somanuals.com>

TV manuals search

<http://tv.somanuals.com>