

0311400

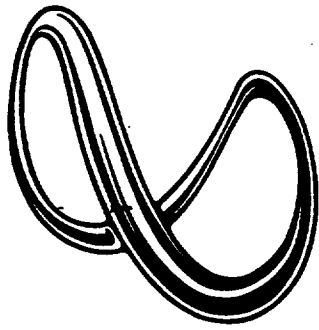

Infinity®

BU-2

POWERED SUBWOOFER

Owner's Manual

Notice D' Emploi

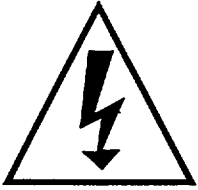

CAUTION

RISK OF ELECTRIC SHOCK DO NOT OPEN

**WARNING: SHOCK HAZARD, DO NOT OPEN.
AVIS: RISQUE DE CHOC ELECTRIQUE – NE PAS OUVRIR.**

**CAUTION: TO REDUCE THE RISK OF ELECTRIC SHOCK
DO NOT REMOVE COVER (OR BACK)
NO USER SERVICEABLE PARTS INSIDE
REFER SERVICING TO QUALIFIED PERSONNEL**

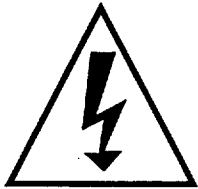

The lightning flash with arrowhead symbol, within an equilateral triangle, is intended to alert the user to the presence of uninsulated “dangerous voltage” within the product’s enclosure that may be of sufficient magnitude to constitute a risk of electric shock to persons.

The exclamation point within an equilateral triangle is intended to alert the user to the presence of important operating and maintenance (servicing) instructions in the literature accompanying the product.

**CAUTION: TO PREVENT ELECTRIC SHOCK, MATCH WIDE BLADE OF
PLUG TO WIDE SLOT, FULLY INSERTED.**

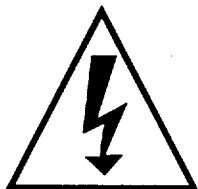

L'éclair avec le symbole de la flèche, placé dans les limites d'un triangle équilatéral est prévu pour avertir l'utilisateur de la présence de “tension dangereuse” non isolée dans l'enceinte du produit qui pourrait être d'une importance suffisante pour présenter un risque d'électrocution aux personnes.

Le point d'exclamation dans un triangle équilatéral est prévu pour avertir l'utilisateur de la présence d'instructions importantes pour les opérations et l'entretien (service) dans les manuels fournis avec l'appareil.

**ATTENTION: POUR EVITER LES CHOCs ELECTRIQUES, INTRODUIRE
LA LAME LA PLUS LARGE DE LA FICHE DANS LA BORNE
CORRESPONDANTE DE LA PRISE ET POUSSER JUSQU'AU FOND.**





BU-2 POWERED SUBWOOFER

ATTENTION!

PLEASE READ THESE INSTRUCTIONS THOROUGHLY BEFORE ATTEMPTING TO OPERATE YOUR INFINITY SUBWOOFER. BE SURE TO SAVE THIS MANUAL FOR FUTURE REFERENCE. ALSO SAVE YOUR BILL OF SALE, AS IT IS REQUIRED FOR WARRANTY SERVICE.

UNPACKING

Check your subwoofer carefully. If it has been damaged in transit, report the damage immediately by calling your dealer and/or the trucking firm that delivered it.

To prevent fire or shock hazard, DO NOT EXPOSE

THIS SUBWOOFER SYSTEM TO RAIN OR EXCESSIVE MOISTURE. To avoid electrical shock, DO NOT OPEN THE SUBWOOFER! There are no user serviceable parts inside. Observe all warnings and cautions.

A FEW SUGGESTIONS

We recommend that you not operate your speakers or subwoofer with the bass, treble and loudness controls set to full boost. This will place undue strain on your electronics and speakers and could damage them.

The volume control setting on your preamplifier or stereo receiver is not a specific indication of the overall loudness level of the speakers. The only important consideration is the loudness level at which the system can be played regardless of where the volume control is set.

Always turn down the volume control setting on your preamplifier or stereo when changing a cassette or CD, or switching inputs to AM or FM operation. Excessively loud transients (clicks or popping sounds) can damage the satellite speakers and possibly the subwoofer.

Whenever changing cables, pulling plugs, etc., ALWAYS TURN OFF ALL EQUIPMENT including the Subwoofer. This prevents transients from entering the speakers and prevents electrical energy from reaching you. Keep all connections out of the reach of children.

ABOUT THIS PRODUCT

The Infinity BU-2 Powered Subwoofer has been designed to enhance the bass frequencies of any audio system. This subwoofer may be used with speakers of any size. Obviously, the greatest bass enhancement will be achieved when the subwoofer is connected with speakers which do not have the capability to create deep bass. This subwoofer may be used individually, or combined with another BU-2 for even more impressive reproduction of bass frequencies (i.e., one subwoofer

near the satellite speakers and a second subwoofer behind the primary listening area or both subwoofers up front).

The BU-2 is a self-powered system utilizing a solid state, low frequency monophonic amplifier driving a specially designed woofer mounted within a structurally rigid, tuned port enclosure.

SPECIFICATIONS

FREQUENCY RESPONSE.....	30 to 150 Hz, \pm 3dB	OUTPUT	100 W _{rms}
CROSSOVER FREQUENCY.....	50 to 200 Hz,	DRIVER	12" Woofer
.....	Continuously Variable	CABINET FINISH.....	Ebony Pica
INPUT SENSITIVITY.....	Low Level: 70 mV	DIMENSIONS.....	14 ¹ / ₂ " W x 14 ¹ / ₂ " H* x 14 ¹ / ₂ " D
.....	High Level: 1.7 V	(36.8 cm W x 36.8 cm H* x 36.8 cm D)
INPUT IMPEDANCE.....	Low Level: 12 k Ω	*Does not include 1 ³ / ₄ " (4.5 cm) for feet
.....	High Level: 5 k Ω		

POSITIONING

Since the installation of a subwoofer is somewhat more complicated than installing full range speakers, it is essential you read this section very carefully prior to connecting the subwoofer to your system. Should you have questions relating to your installation, it is advisable to call either your dealer or Infinity's Customer Service Department for advice.

The performance of the subwoofer is directly related to its placement in the listening room and how you align the subwoofer with its satellite speakers. Setting the volume of the subwoofer in relationship to the left and right speakers is also of critical importance because it is essential that the subwoofer integrates smoothly with the entire system. Setting the subwoofer's volume level too high will result in an overpowering, boomy bass. Setting the volume level too low will negate the effect of the subwoofer.

The metal plate acts as the heat sink for the subwoofer's internal amplifier. Do not place pillows or other objects against it.

We recommend placing the BU-2 at least 2 to 3 feet away from a television or a computer's disc drive system to prevent smearing the colors of the TV picture or erasure of the magnetic drive.

Here are several additional facts on installation which may prove useful. It is generally believed by most audio authorities that low frequencies (below 125 Hz) are non-directional and, therefore, placement of a subwoofer within any listening room is not critical. While in theory it is true that extremely low frequencies because of their larger wave lengths are basically non-directional, the fact is when installing a subwoofer within the limited confines of a room, reflections, standing waves and absorptions generated within the room will strongly influence the performance of any subwoofer system. As a result, specific location of the subwoofer becomes important, and we strongly recommend that you experiment with room placement before choosing a final location.

Placement will depend upon your room and the amount and quality of bass required. For example, if your room permits placement of the subwoofer near either satellite. Never place the port too close to a wall or piece of furniture, as this will prevent the port from operating properly. Since the port is an integral part of the subwoofer's design, it should always be permitted free access to the listening room without obstruction to the pressure emerging from it. Careful experimentation will enable you to determine the best position for the subwoofer.

Here are some useful hints:

1. Experimentation with the port direction may be useful. At times directing the port away from the listening area (to the side) may be advantageous because this may create a better blend of bass within the listening room.
2. If bass response seems inadequate, move it closer to a wall or corner. If bass becomes too heavy, try turning the subwoofer with the port facing away from the wall. This will tend to diminish bass output.

It will take time and patience to find the most pleasing acoustic location for your subwoofer. Testing for sonic balance and blending should always be made for your normal listening position using a wide range of source material. As a starting point, initially place the subwoofer behind your right channel satellite speaker, about 3 or 4 inches from the wall. (We suggest trying this location first because in an orchestra, the bass instruments are usually located in the back and to the right.) Refer to Figure 1.

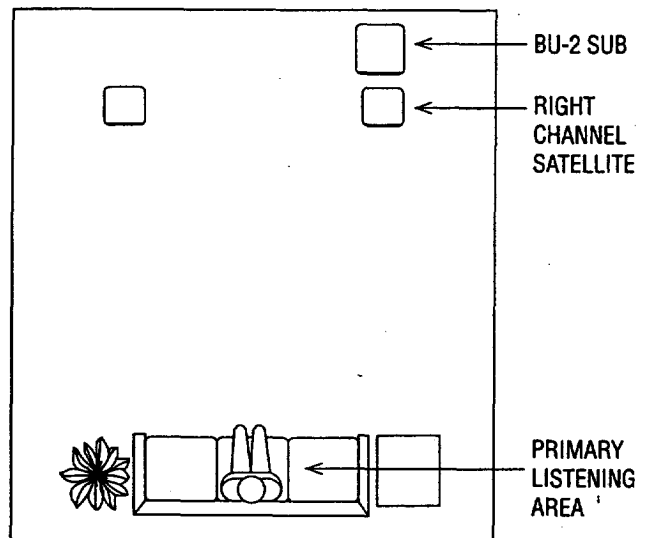

Figure 1

IDENTIFICATION OF CONTROLS AND CONNECTING AC POWER

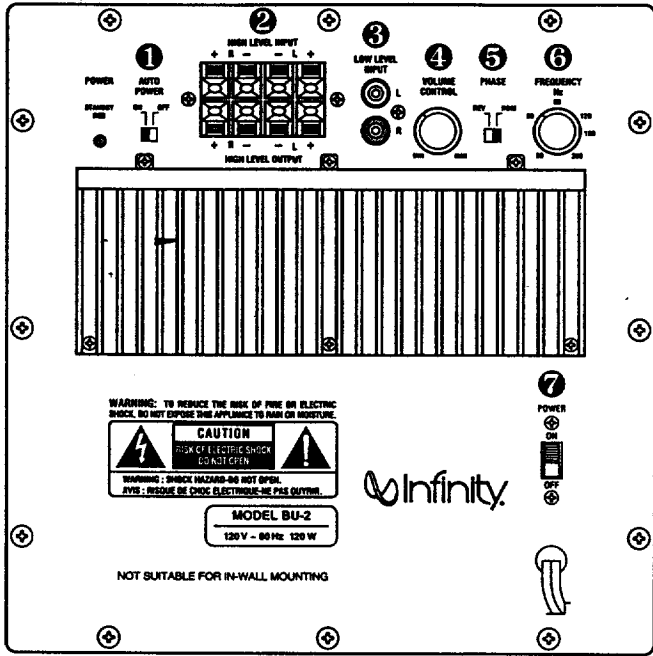

Figure 2

Refer to *Figure 2* to identify the controls of your subwoofer's internal amplifier:

- ❶ Auto Power: on/off switch for auto-sensing of audio signal
- ❷ High Level Input and Output terminal strips
- ❸ Low Level Input jacks: connect to preamplifier outputs
- ❹ Volume Control: controls volume of subwoofer
- ❺ Phase: reverse/normal switch to flip audio signal polarity
- ❻ Frequency: controls upper corner roll-off point
- ❼ AC Power: on/off switch for ac power to amplifier

Turn off your entire audio system prior to connecting your subwoofer. Make sure the subwoofer's ON/OFF switch is in the "OFF" position. If using an unswitched ac outlet on your receiver or amplifier is not possible, connect your subwoofer to an unswitched ac wall outlet.

When the Auto Power switch is set to ON (and AC Power is also ON), the BU-2's auto-sensing circuit will automatically turn the subwoofer on when music or voice signals are detected. When audio is absent, the BU-2 will stay in the "on" mode (as indicated by a green LED) for approximately 8 minutes before the auto-sensing circuit shuts down the system (as indicated by a red LED). To defeat this feature, set Auto Power to OFF and use the AC Power switch to turn on/off the BU-2.

CONNECTING YOUR SUBWOOFER

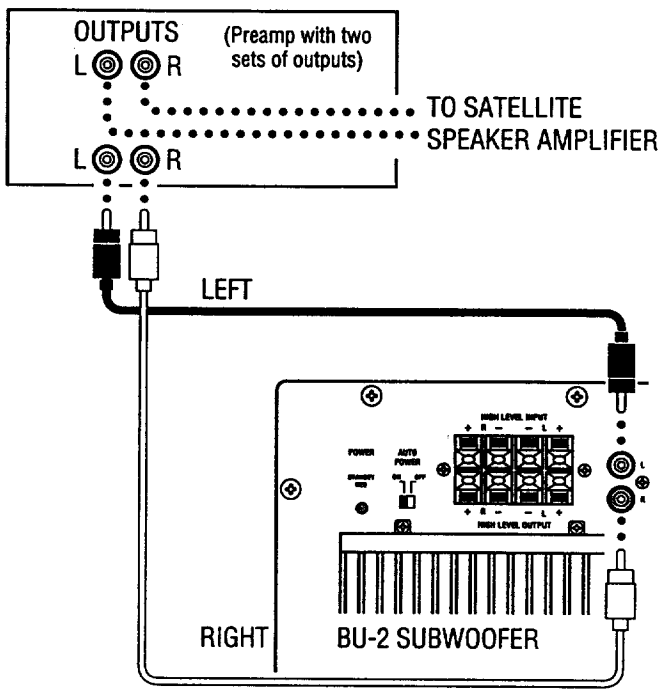

Figure 3a

There are several ways to connect your BU-2 subwoofer. Read this section carefully to determine which method is best suited for your installation.

The BU-2 may be fed directly with a low-level signal taken from your preamplifier's output by using the second set of output jacks on the rear of your preamplifier (see *Figure 3a*). If your preamplifier has only one set of outputs you may use two (2) "Y" connectors (see *Figure 3b*) to connect your subwoofer. Use standard shielded leads terminated at each end with male RCA connectors. Connect one end of each stereo pair of leads to your preamplifier's left and right outputs and connect the other end to the corresponding left and right LOW LEVEL INPUTS (1) on the subwoofer.

NOTE: If you are using a tube preamplifier and the connecting leads will be longer than 10 feet (3 meters), we recommend not using the above connection method. A tube preamplifier may not be able to handle the capacitance introduced by leads over 10 feet in length. Instead, try using the high-level connection methods listed on page 5.

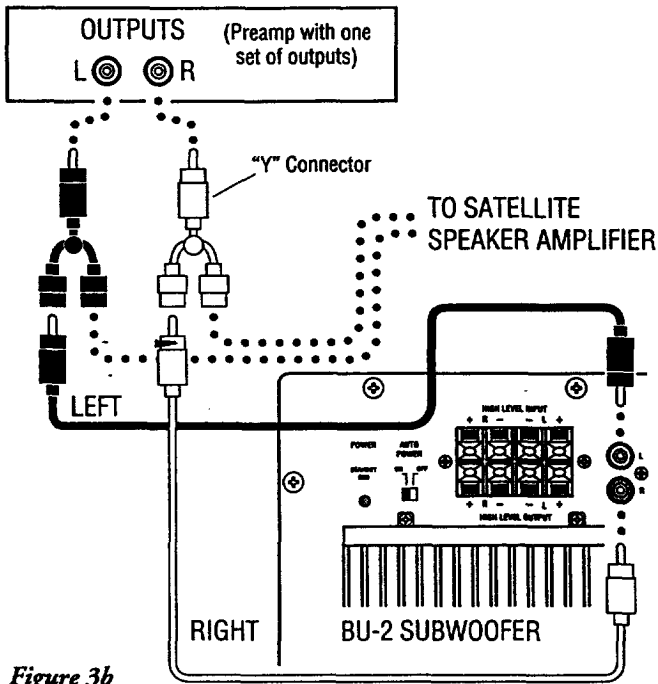

Figure 3b

When using a single subwoofer, you **MUST** use a pair of stereo low-level leads from your preamplifier's outputs. When using two subwoofers, one for the left and another for the right channel, connect the left preamplifier output to **BOTH** the left and right **LOW LEVEL INPUTS** of the subwoofer used for the left channel by using a Female-to-Male "Y" connector at the subwoofer's input and the right channel preamplifier output to both jacks of the right channel subwoofer in the same manner (see Figure 4). If the preamplifier has a mono subwoofer output, you'll also need a Male-to-Female "Y" connector to split the mono signal to the subwoofer pair (see Figure 4).

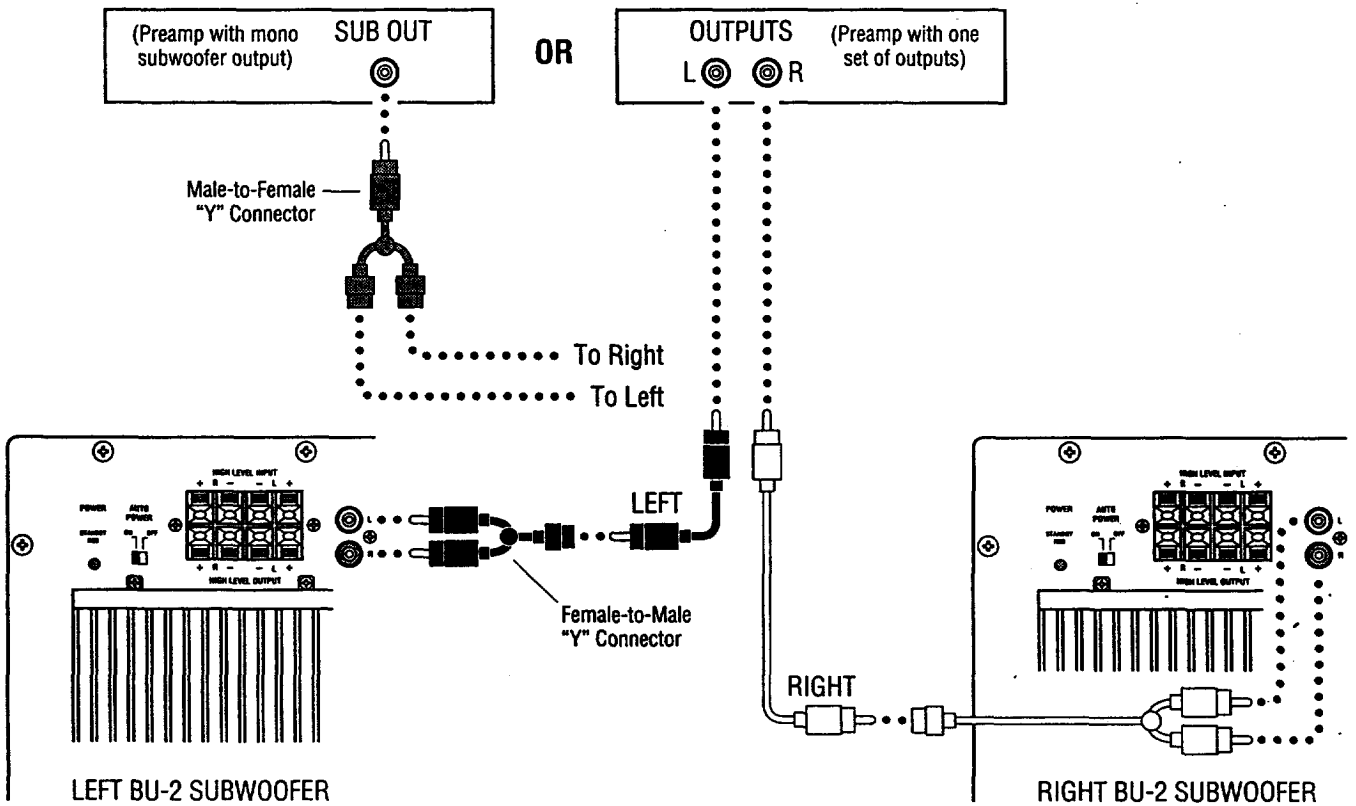

Figure 4

The BU-2 subwoofer may be connected to your system using the HIGH LEVEL INPUTS (4) on the plate located on the rear panel of the subwoofer. Use ordinary lamp cord maintaining proper polarity (+ to + and - to -). Attach the lamp cord to the left and right HIGH LEVEL INPUTS on the subwoofer and the other ends to the proper left and right OUTPUTS on your amplifier or receiver (see Figure 5).

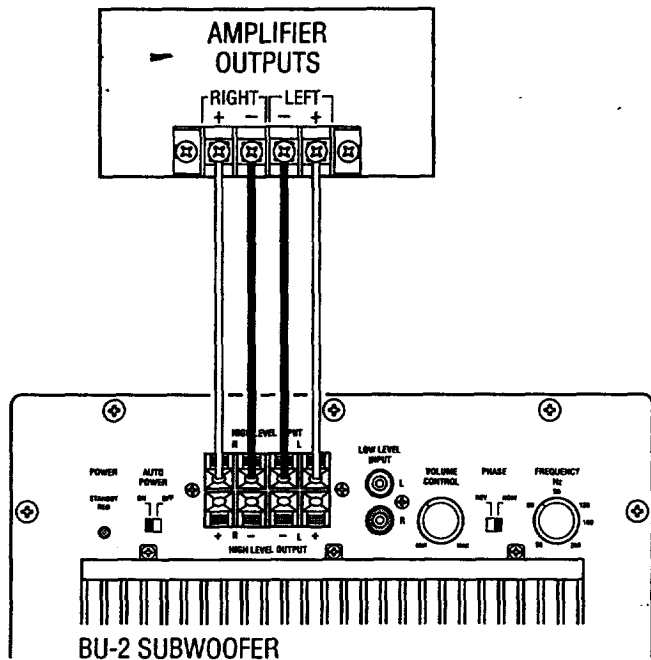

Figure 5

If you plan to use two subwoofers (one for the left and the other for the right channel) connect wires from the left and right OUTPUT on your power amplifier or receiver and attach the other ends to the corresponding HIGH LEVEL INPUTS on each subwoofer. Observe polarity (see Figure 6).

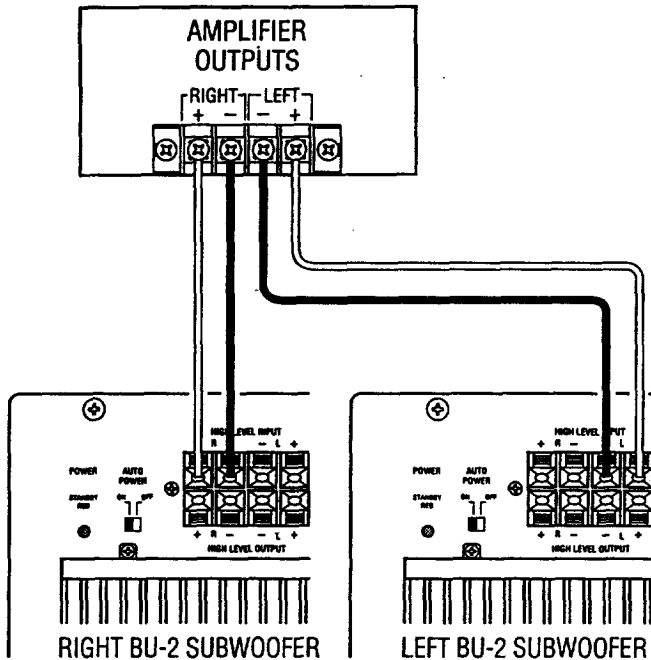

Figure 6

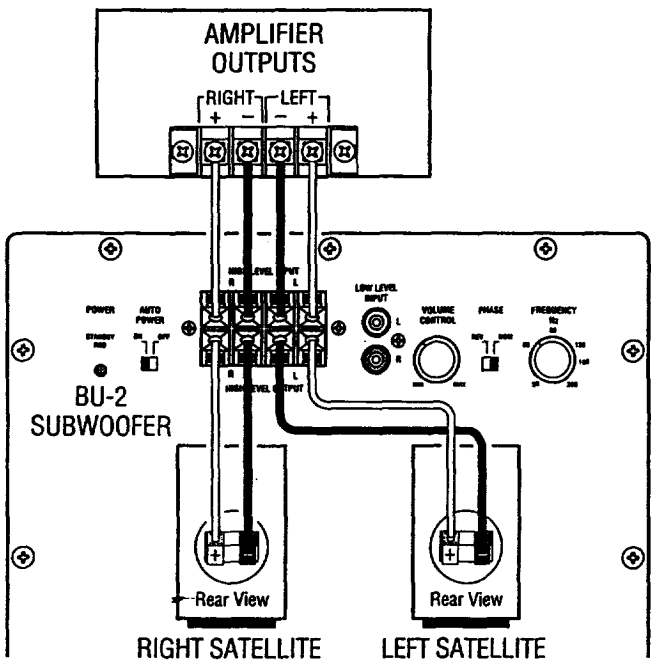
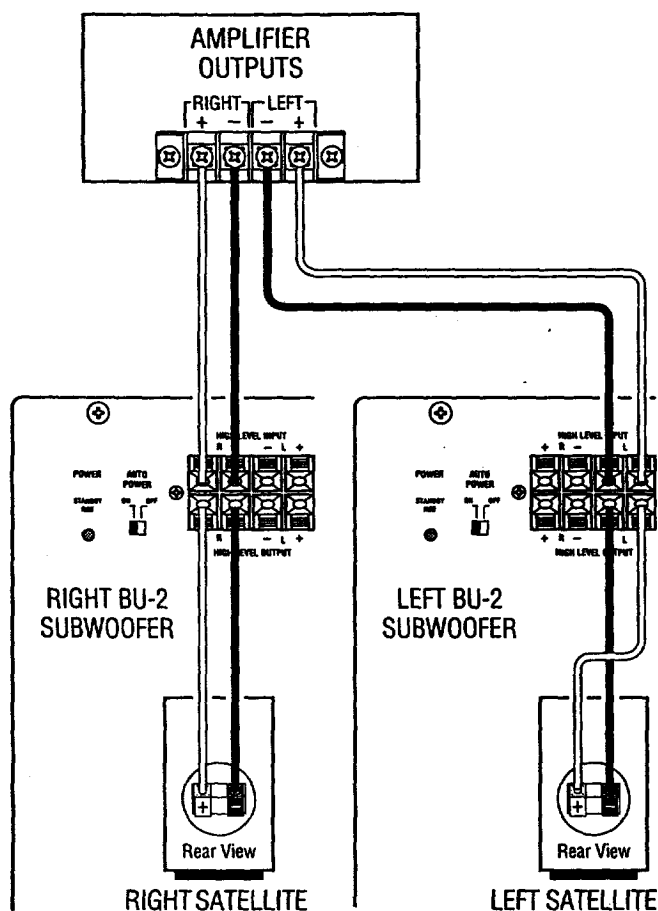

Figure 7

Depending on whether you are using one or two BU-2 subwoofers, connecting your satellites can be accomplished in one of two ways. If you are using a single BU-2 with a pair of satellites, connect them as shown in Figure 7.



If you are using two BU-2 subwoofers as a stereo pair with a pair of satellites, connect them as shown in *Figure 8*.

NOTE: The BU-2 subwoofer does not have a built-in passive crossover which would roll off your satellites' lower frequencies. However, the BU-2 does have a variable frequency control that can be used to block unwanted frequencies (between 50 - 200 Hz) from being reproduced by the subwoofer. Where you set this control depends on the low frequency capabilities of your satellite speakers. Adjust this knob to the lowest frequency that your satellite speakers were designed to reproduce (*refer to Operation, step 8*).

Figure 8

OPERATION

1. Initially set the BU-2's Volume control ④ (*Fig. 2*) to 12 o'clock.
2. Initially set the BU-2's Frequency control ⑥ (*Fig. 2*) to 12 o'clock.
3. Slide the BU-2's Phase switch ⑤ (*Fig. 2*) to the "NOM" position (for normal polarity).
4. (Optional) Slide the BU-2's Auto Power switch ① (*Fig. 2*) to the "ON" position (otherwise "OFF" defeats auto-sensing).
5. Turn on your entire audio system.
6. Turn the Volume control ④ (*Fig. 2*) to its mid position. If no sound emanates from the subwoofer after the auto-sensing system turns it on (i.e., LED goes from red to green), check the ac line cord and input cables. Are the connectors on the cables making proper contact? Is the ac plug connected to a "live" receptacle? Once you have confirmed that the subwoofer is active, proceed by playing a CD, record, or cassette. Use a selection that has ample bass information.
7. Set the overall volume control of the preamplifier or stereo to a comfortable level. Adjust the subwoofer's Volume control ④ (*Fig. 2*) until you obtain a pleasing blend of bass. Bass response should not overpower the room, but rather be adjusted so there is a harmonious blend across the entire musical range. Many users have a tendency to set the

subwoofer volume too loud following the belief that a subwoofer is there to produce lots of bass. This is not entirely true. A subwoofer is there to enhance bass, extending the response of the entire system so the bass can be felt as well as heard. However, overall balance must be maintained; otherwise, the music will not sound natural. An experienced listener will set the volume of the subwoofer so its impact on bass response is always there but is never obtrusive.

8. The Frequency control ⑥ (*Fig. 2*) sets the high frequency roll-off, adjustable from 50 to 200 Hz. Where you set this control depends on the low frequency capabilities of your satellite speakers, system placement, and other factors affecting the mid-bass region. Turn the control UP (clockwise) until you feel there is too much mid-bass information (around 100Hz) then back the control down a bit until that area sounds more natural. To hear more low bass, turn the Frequency control DOWN a bit and the Volume control UP by about the same amount. This will increase low bass while leaving the mid-bass sounding the same as it did before the adjustment. To reduce low bass without changing mid-bass, turn the Frequency control UP and the Volume control DOWN. Alternately slide the Phase switch between "NOM" and "REV" positions while listening to music. The selection that sounds the best is the correct adjustment for your system.

9. Room placement of the subwoofer is the most critical aspect of its installation. It will be necessary for you to try various locations in your listening room before you choose the final location. Some possible starting points include: behind the right channel satellite speaker, along the back wall between the satellites, along a side wall (but not too close to a corner), or behind a couch or a chair.

In general, the closer the subwoofer is to walls and corners, the greater the effect of low frequency enhancement. Experiment with the Frequency and Volume controls in different locations until you are pleased with the result you obtain from your particular application.

A WORD OF ADVICE

The low Frequency rolloff and Volume controls may be set anywhere within their rotation. However, it will be a most unusual circumstance if you have to set the Volume control completely clockwise. This may indicate an unbalanced condition in your system (too much bass) or an especially large room, or room placement may not be correct. Try several other locations before concluding that the Volume control must be set at maximum.

If the subwoofer is located so far from the listening area that its effect is not as prominent as desired, try reversing the audio signal polarity by sliding the Phase switch from NOM to REV.

OVERDRIVE PROTECTION

Automatic limiting circuitry helps prevent overdriving a connected subwoofer by softly clipping the input signal if it exceeds a predetermined threshold. Depending on the level, you may or may not hear slight distortion on musical peaks. This protection is completely automatic, with no user

adjustments. However, if you do hear distortion continuously while playing music, the input signal level (feeding the BU-2) may be too high and should be lowered. If this doesn't solve the problem, verify the connections and check for proper operation of other components in the audio chain.

A WORD ABOUT TONE CONTROLS

The tone controls on your electronic components (preamplifier, receiver, etc.) should be used with the utmost discretion. Excessive boost can create severe power demands on your power amplifier. Maximum bass boost can create a demand for literally hundreds of watts in the bass region,

whereas, in the "flat" position, or with the tone controls switched out of the system, your average listening level may be impressively and realistically loud at less than 10 watts. The remaining power capacity required is on reserve for power peaks on sharp transients and powerful crescendos.

CARE OF YOUR SUBWOOFER

Your Infinity subwoofer cabinet is finished with a heavy duty, high quality vinyl which requires very little maintenance. Keep the cabinet clean by dusting it occasionally with a damp cloth or use a good quality furniture polish to maintain its

original luster. (When using aerosol products, always spray the cloth, not the speaker, to prevent any of the product from drifting onto the electronics of the unit.)

FEEDBACK

If the bass seems boomy, or you notice a rumbling sound when listening to record albums, the cause may be acoustic feedback. This means that low frequency vibrations from your speakers are reaching the turntable. To help isolate the turntable from these vibrations, place the turntable on a heavy, solid support, as far away as possible from the

subwoofer. If you continue to experience difficulties after experimenting with placement, consult your Infinity dealer.

NOTE: CD players are also susceptible to acoustic feedback and should be placed on solid supports to isolate them acoustically. Another method to isolate the CD player is to place it on four isolation feet available at your local dealer.

IN CASE OF TROUBLE WITH YOUR SUBWOOFER

If the subwoofer sound is distorted, stops playing, or otherwise seems to be malfunctioning, first determine if the problem is in the subwoofer or the wiring and/or other audio components. If the problem also affects the satellite speakers, the cause is most likely in your electronics. If it is only noticed in the subwoofer, make sure that all connecting cables are correct and in proper working condition. Make sure the subwoofer is plugged in and turned on.

If everything seems to be in good working order and the subwoofer still malfunctions, **DO NOT ATTEMPT ANY**

REPAIRS! Contact your Infinity dealer and get the name of the authorized Infinity service center near you. If there is no facility near you, contact Infinity's Customer Service Department at (818)407-0228, or write:

Infinity Systems, Inc. – CUSTOMER SERVICE
20630 Nordhoff St., Chatsworth, CA 91311 U.S.A.

NOTE: Do not ship your subwoofer for service without prior approval (RETURN AUTHORIZATION), and do not ship without enclosing a copy of your original bill-of-sale.

LIMITED WARRANTY

Who is protected by the warranty?

Your Infinity warranty protects the original retail purchaser and all subsequent owners, during the stated warranty period, from any failure as a result of an original manufacturing defect so long as: (1) your Infinity product was purchased within the fifty United States, or purchased by military personnel from an authorized military outlet, and (2) the original dated bill of sale is presented whenever service is required during the warranty period. This warranty does not apply to products purchased elsewhere; other purchasers should contact their local Infinity distributor for warranty information.

How long is the warranty period?

Speaker components are covered for parts and labor for a period of five (5) years. Electronic assemblies are covered for parts and labor for a period of one (1) year.

What does the Infinity warranty cover?

Except as specified below, this warranty covers all defects in original materials and workmanship. The following are not covered: damage caused by accident, misuse, abuse, neglect, product modification; damage occurring during shipment; damage caused by failure to follow instructions in the owner's manual, including failure to perform recommended periodic or routine maintenance; damage resulting from repairs by someone not authorized by Infinity; claims based upon any misrepresentations by the seller; and any Infinity product on which the serial number has been altered, defaced or removed.

Who pays for what?

During the period that both parts and labor are covered by this warranty, Infinity will pay all of the labor and material expenses to repair a warrantable defect; during the period that parts **ONLY** are covered by this warranty, Infinity will pay for all materials to correct warranted defect, but you must pay for the labor charges.

How can warranty service be obtained?

In the event that your Infinity product requires service, you should first contact the Infinity dealer from whom the product was purchased or if this is not practical, contact Infinity directly (ATTN: Customer Service) at 20630 Nordhoff St., Chatsworth, CA 91311 U.S.A.; (818) 407-0228. We may direct you to an authorized service center for Infinity products or ask you to send them to us for repair. In either case, you must present your original dated bill-of-sale to establish warranty coverage. Do not send your product to us without prior authorization from our Customer Service Department.

You are responsible for transporting your product for repair and for payment of all shipping charges; however, Infinity will pay the return shipping charges (in the event you return the product to us) if the repairs are covered by warranty. If you experience difficulty in transporting your product or are in need of packing materials, please advise us and we may be able to suggest alternative procedures and/or provide adequate packing materials.

Limitation of Implied Warranties:

All implied warranties, including fitness for a particular purpose and merchantability are limited in duration and length to the warranty period for your product.

Limitation of Incidental or Consequential Damages:

Infinity is not responsible for any incidental or consequential damage of any kind. Our liability is limited to the repair or replacement, at our option, of a defective product. Some states do not allow limitations on how an implied warranty lasts and/or do not allow the exclusion of incidental or consequential damage, so the above limitations or exclusions may not apply to you. This warranty gives you specific legal rights and you may also have other rights which vary from state to state.

NOTE: In the event that there is a difference between this warranty and the provisions in any advertisements, product brochures or packaging cartons, the terms of this warranty will prevail.

IMPORTANT SAFETY INSTRUCTIONS

1) **Read Instructions** – All the safety and operating instructions should be read before the product is operated.

2) **Retain Instructions** – The safety and operating instructions should be retained for future reference.

3) **Heed Warnings** – All warnings on the product and in the operating instructions should be adhered to.

4) **Follow Instructions** – All operating and use instructions should be followed.

5) **Cleaning** – Unplug this product from the wall outlet before cleaning. Do not use liquid cleaners or aerosol cleaners. Use a damp cloth for cleaning.

Exception: A product that is meant for uninterrupted service and that for some specific reason, such as the possibility of the loss of an authorization code for a CATV Converter, is not intended to be unplugged by the user for cleaning or any other purpose, may exclude the reference to unplugging the product in the product in the cleaning description otherwise required in above 5).

6) **Attachments** – Do not use attachments not recommended by the product manufacturer as they may cause hazards.

7) **Water and Moisture** – Do not use this product near water – for example, near a bath tub, wash bowl, kitchen sink, or laundry tub; in a wet basement; or near a swimming pool; and the like.

8) **Accessories** – Do not place this product on an unstable cart, stand, tripod, bracket, or table. The product may fall, causing serious injury to a child or adult, and serious damage to the product. Use only with a cart, stand, tripod, bracket, or table recommended by the manufacturer, or sold with the product. Any mounting of the product should follow the manufacturer's instructions, and should use a mounting accessory recommended by the manufacturer.

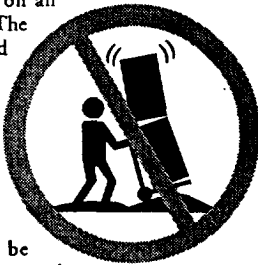

9) A product and cart combination should be moved with care. Quick stop, excessive force, and uneven surfaces may cause the product and cart combination to overturn.

10) **Ventilation** – Slots and openings in the cabinet are provided for ventilation and to ensure reliable operation of the product and to protect it from overheating, and these openings must not be blocked or covered. The openings should never be blocked by placing the product on a bed, sofa, rug, or other similar surface. This product should not be placed in a built-in installation such as a bookcase or rack unless proper ventilation is provided or the manufacturer's instructions have been adhered to.

11) **Power Sources** – This product should be operated only from the type of power source indicated on the marking label. If you are not sure of the type of power supply to your home, consult your product dealer or local power company. For products intended to operate from battery power, or other sources, refer to the operating instructions.

12) **Grounding or Polarization** – This product may be equipped with a polarized alternating-current line plug (a plug having one blade wider than the other). This plug will fit into the power outlet only one way. This is a safety feature. If you are unable to insert the plug fully into the outlet, try reversing the plug. If the plug should still fail to fit, contact your electrician to replace your obsolete outlet. Do not defeat the safety purpose of the polarized plug.

13) **Power-Cord Protection** – Power-supply cords should be routed so that they are not likely to be walked on or pinched by items placed upon or against them, paying particular attention to cords at plugs, convenience receptacles, and the point where they exit from the product.

14) **Outdoor Antenna Grounding** – If an outside antenna or cable system is connected to the product, be sure the antenna or cable system is grounded so as to provide some protection against voltage surges and built-up static charges. Article 810 of the National Electrical Code, ANSI/NFPA 70, provides information with regard to proper grounding of the mast and supporting structure, grounding of the lead-in wire to an antenna discharge unit, size for grounding conductors, location of antenna-discharge unit, connection to grounding electrodes, and requirements for the grounding electrode. See Figure A.

Figure A

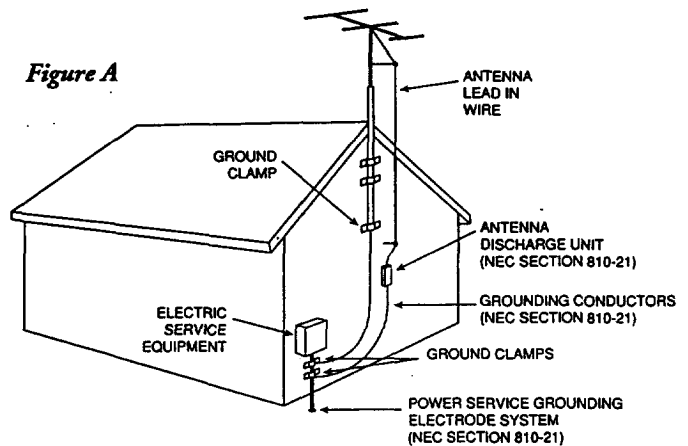

15) **Lightning** – For added protection for this product during a lightning storm, or when it is left unattended and unused for long periods of time, unplug it from the wall outlet and disconnect the antenna or cable system. This will prevent damage to the product due to lightning and power-line surges.

16) **Power Lines** – An outside antenna system should not be located in the vicinity of overhead power lines or other electric light or power circuits, or where it can fall into such power lines or circuits. When installing an outside antenna system, extreme care should be taken to keep from touching such power lines or circuits as contact with them might be fatal.

17) **Overloading** – Do not overload wall outlets, extension cords, or integral convenience receptacles as this can result in a risk of fire or electric shock.

18) **Object and Liquid Entry** – Never push objects of any kind into this product through openings as they may touch dangerous voltage points or short-out parts that could result in a fire or electric shock. Never spill liquid of any kind on the product.

19) **Servicing** – Do not attempt to service this product yourself as opening or removing covers may expose you to dangerous voltage or other hazards. Refer all servicing to qualified service personnel.

20) **Damage Requiring Service** – Unplug this product from the wall outlet and refer servicing to qualified service personnel under the following conditions:

- a) When the power-supply cord or plug is damaged.
- b) If liquid has been spilled, or objects have fallen into the product.
- c) If the product has been exposed to rain or water.
- d) If the product does not operate normally by following the operating instructions. Adjust only those controls that are covered by the operating instructions as an improper adjustment of other controls may result in damage and will often require extensive work by a qualified technician to restore the product to its normal operation.
- e) If the product has been dropped or damaged in any way.
- f) When the product exhibits a distinct change in performance – this indicated a need for service.

21) **Replacement Parts** – When replacement parts are required, be sure the service technician has used replacement parts specified by the manufacturer or have the same characteristics as the original part. Unauthorized substitutions may result in fire, electric shock, or other hazards.

22) **Safety Check** – Upon completion of any service or repairs to this product, ask the service technician to perform safety checks to determine that the product is in proper operating condition.

23) **Wall or Ceiling Mounting** – The product should be mounted to a wall or ceiling only as recommended by the manufacturer.

24) **Heat** – The product should be situated away from heat sources such as radiators, heat registers, stoves, or other products (including amplifiers) that produce heat.

Free Manuals Download Website

<http://myh66.com>

<http://usermanuals.us>

<http://www.somanuals.com>

<http://www.4manuals.cc>

<http://www.manual-lib.com>

<http://www.404manual.com>

<http://www.luxmanual.com>

<http://aubethermostatmanual.com>

Golf course search by state

<http://golfingnear.com>

Email search by domain

<http://emailbydomain.com>

Auto manuals search

<http://auto.somanuals.com>

TV manuals search

<http://tv.somanuals.com>