

JVC

SERVICE MANUAL

DIGITAL VIDEO CAMERA

GR-D20EK, GR-D20Ex, GR-D20Ey, GR-D20Ez, GR-D21EK, GR-D40EK, GR-D40Ex, GR-D40Ey, GR-D40Ez

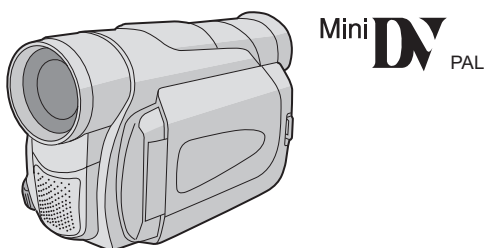

For disassembling and assembling of MECHANISM ASSEMBLY, refer to the SERVICE MANUAL No.86700 (MECHANISM ASSEMBLY).

SPECIFICATION

Camcorder		Connectors	
General		S-Video Output	
Power supply	: DC 11.0 V $\overline{\text{---}}$ (Using AC Adapter) DC 7.2 V $\overline{\text{---}}$ (Using battery pack)	Output	: Y : 1 V (p-p), 75 Ω , analogue C : 0.29 V (p-p), 75 Ω , analogue
Power consumption		Input*	: Y : 0.8 V (p-p) -1.2 V (p-p), 75 Ω , analogue C : 0.2 V (p-p) -0.4 V (p-p), 75 Ω , analogue
LCD monitor off, viewfinder on:	Approx. 3.4 W	AV Video output	: 1 V (p-p), 75 Ω , analogue
LCD monitor on, viewfinder off:	Approx. 4.7 W	Video input*	: 0.8 V (p-p) -1.2 V (p-p), 75 Ω , analogue
Dimensions (W x H x D)	: 69 mm x 94 mm x 143 mm (with the LCD monitor closed and the viewfinder pushed back in)	Audio output	: 300 mV (rms), 1 k Ω , analogue, stereo
Weight	: Approx. 525 g	Audio input*	: 300 mV (rms), 50 k Ω , analogue, stereo
Operating temperature	: 0°C to 40°C	DV Output	: 4-pin, IEEE 1394 compliant
Operating humidity	: 35% to 80%	Input*	: 4-pin, IEEE 1394 compliant
Storage temperature	: -20°C to 50°C	USB**	: 5-pin
Pickup	: 1/6" CCD	EDIT	: \varnothing 3.5 mm, 2-pole
Lens	: F 1.6, f = 2.7 mm to 43.2 mm, 16:1 power zoom lens		
Filter diameter	: \varnothing 37 mm		
LCD monitor	: 2.5" diagonally measured, LCD panel/TFT active matrix system		
Viewfinder	: Electronic viewfinder with 0.24" black/white LCD		
Speaker	: Monaural		
Digital Video Camera		AC Adapter	
Format	: DV format (SD mode)	Power requirement	: AC 110 V to 240 V \sim , 50 Hz/60 Hz
Signal format	: PAL standard	Output	: DC 11 V $\overline{\text{---}}$, 1 A
Recording/Playback format	: Video: Digital component recording Audio: PCM digital recording, 32 kHz 4-channel (12-bit), 48 kHz 2-channel (16-bit)		
Cassette	: Mini DV cassette		
Tape speed	: SP : 18.8 mm/s LP : 12.5 mm/s		
Maximum recording time (using 80 min. cassette)	: SP : 80 min. LP : 120 min.		

Specifications shown are for SP mode unless otherwise indicated. E & O.E. Design and specifications subject to change without notice.

TABLE OF CONTENTS

1 PRECAUTIONS	1-3
1.1 SAFTY PRECAUTIONS	1-3
2 SPECIFIC SERVICE INSTRUCTIONS	1-5
2.1 BEFORE ASSEMBLY AND DISASSEMBLY	1-5
2.2 ASSEMBLY AND DISASSEMBLY OF CABINET PARTS	1-6
2.3 ASSEMBLY AND DISASSEMBLY OF CAMERA SECTION AND BOARD ASSEMBLY	1-10
2.4 ASSEMBLY AND DISASSEMBLY OF [8]VF ASSEMBLY	1-12
2.5 ASSEMBLY AND DISASSEMBLY OF [10]MONITOR ASSEMBLY (CABINET PARTS)	1-13
2.6 ASSEMBLY AND DISASSEMBLY OF [2]OP BLOCK ASSEMBLY / CCD BOARD ASSEMBLY (CAMERA SECTION AND BOARD ASSEMBLY)	1-14
2.7 SERVICE NOTE	1-15
2.8 TAKE OUT CASSETTE TAPE	1-16
2.9 EMERGENCY DISPLAY	1-17
3 ADJUSTMENT	1-18
3.1 PREPARATION	1-18
3.2 TOOLS REQUIRED FOR ADJUSTMENT	1-18
3.3 JIG CONNECTOR CABLE	1-20
3.4 MECHANISM ADJUSTMENT	1-21
3.5 ELECTRICAL ADJUSTMENT	1-22

CHARTS AND DIAGRAMS

BOARD INTERCONNECTIONS	2-3
MAIN IF SCHEMATIC DIAGRAM	2-5
CPU SCHEMATIC DIAGRAM	2-7
AUDIO SCHEMATIC DIAGRAM	2-9
DV MAIN SCHEMATIC DIAGRAM	2-11
VIDEO I/O SCHEMATIC DIAGRAM	2-13
CAMERA DSP SCHEMATIC DIAGRAM	2-15
OP DRIVER SCHEMATIC DIAGRAM	2-17
TG SCHEMATIC DIAGRAM	2-19
REG SCHEMATIC DIAGRAM	2-21
AV STRM SCHEMATIC DIAGRAM	2-23
MONI-BW SCHEMATIC DIAGRAM	2-25
BL-2.5 SCHEMATIC DIAGRAM	2-27
CCD SCHEMATIC DIAGRAM	2-28
JACK SCHEMATIC DIAGRAM	2-29
PREMDA IF SCHEMATIC DIAGRAM	2-30
MDA SCHEMATIC DIAGRAM	2-31
PRE/REC SCHEMATIC DIAGRAM	2-33
B/W-VF SCHEMATIC DIAGRAM	2-35
ZOOM UNIT SCHEMATIC DIAGRAM	2-36
MAIN CIRCUIT BOARD	2-37
COMPONENT PARTS LOCATION GUIDE <MAIN>	2-41
COMPONENT PARTS LOCATION GUIDE <PREMDA>	2-42
PREMDA CIRCUIT BOARD	2-43
MONI-BW CIRCUIT BOARD	2-47
BL-2.5 CIRCUIT BOARD	2-48
JACK CIRCUIT BOARD	2-49
CCD CIRCUIT BOARD	2-50
B/W-VF CIRCUIT BOARD	2-50
POWER SYSTEM BLOCK DIAGRAM	2-51
VIDEO BLOCK DIAGRAM	2-53
VOLTAGE CHARTS	2-57

PARTS LIST

1. EXPLODED VIEW	3-1
1.1 PACKING AND ACCESSORY ASSEMBLY <M1>	3-1
1.2 FINAL ASSEMBLY <M2>	3-2
1.3 MECHANISM ASSEMBLY <M3>	3-4
1.4 ELECTRONIC VIEWFINDER ASSEMBLY <M4>	3-5
1.5 MONITOR ASSEMBLY (2.5 INCH) <M5>	3-6
2. PARTS LIST	3-7

MODEL	GR-D20EK	GR-D20EX	GR-D20EY	GR-D20EZ	GR-D21EK	GR-D40EK	GR-D40EX	GR-D40EY	GR-D40EZ
DIGITAL INTERFACE	NO	NO	NO	NO	NO	USB	USB	USB	USB
POWER CORD	BS TYPE	CEE TYPE	CEE TYPE	CEE TYPE	BS TYPE	BS TYPE	CEE TYPE	CEE TYPE	CEE TYPE
USB CABLE	NO	NO	NO	NO	NO	YES	YES	YES	YES
CD-ROM	NO	NO	NO	NO	NO	YES	YES	YES	YES

SECTION 1 PRECAUTIONS

1.1 SAFTY PRECAUTIONS

Prior to shipment from the factory, JVC products are strictly inspected to conform with the recognized product safety and electrical codes of the countries in which they are to be sold. However, in order to maintain such compliance, it is equally important to implement the following precautions when a set is being serviced.

1.1.1 Precautions during Servicing

(1) Locations requiring special caution are denoted by labels and inscriptions on the cabinet, chassis and certain parts of the product. When performing service, be sure to read and comply with these and other cautionary notices appearing in the operation and service manuals.

(2) Parts identified by the Δ symbol and shaded () parts are critical for safety.

Replace only with specified part numbers.

NOTE :

Parts in this category also include those specified to comply with X-ray emission standards for products using cathode ray tubes and those specified for compliance with various regulations regarding spurious radiation emission.

(3) Fuse replacement caution notice.
Caution for continued protection against fire hazard.
Replace only with same type and rated fuse(s) as specified.

(4) Use specified internal wiring. Note especially:

- Wires covered with PVC tubing
- Double insulated wires
- High voltage leads

(5) Use specified insulating materials for hazardous live parts.
Note especially:

- Insulation Tape
- PVC tubing
- Spacers
- Insulation sheets for transistors
- Barrier

(6) When replacing AC primary side components (transformers, power cords, noise blocking capacitors, etc.) wrap ends of wires securely about the terminals before soldering.

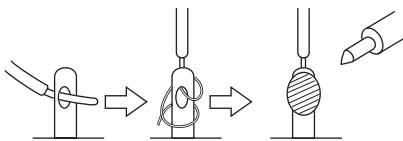

Fig.1-1-1

(7) Observe that wires do not contact heat producing parts (heatsinks, oxide metal film resistors, fusible resistors, etc.)

(8) Check that replaced wires do not contact sharp edged or pointed parts.

(9) When a power cord has been replaced, check that 10-15 kg of force in any direction will not loosen it.

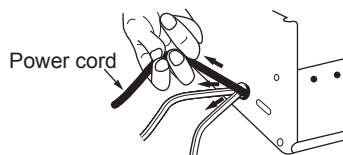

Fig.1-1-2

(10) Also check areas surrounding repaired locations.

(11) Products using cathode ray tubes (CRTs) In regard to such products, the cathode ray tubes themselves, the high voltage circuits, and related circuits are specified for compliance with recognized codes pertaining to X-ray emission. Conse-

quently, when servicing these products, replace the cathode ray tubes and other parts with only the specified parts. Under no circumstances attempt to modify these circuits. Unauthorized modification can increase the high voltage value and cause X-ray emission from the cathode ray tube.

(12) Crimp type wire connector

In such cases as when replacing the power transformer in sets where the connections between the power cord and power transformer primary lead wires are performed using crimp type connectors, if replacing the connectors is unavoidable, in order to prevent safety hazards, perform carefully and precisely according to the following steps.

• **Connector part number** :E03830-001

• **Required tool** : Connector crimping tool of the proper type which will not damage insulated parts.

• **Replacement procedure**

a) Remove the old connector by cutting the wires at a point close to the connector.

Important : Do not reuse a connector (discard it).

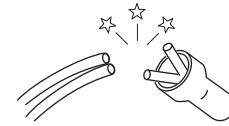

Fig.1-1-3

b) Strip about 15 mm of the insulation from the ends of the wires. If the wires are stranded, twist the strands to avoid frayed conductors.

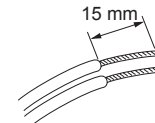

Fig.1-1-4

c) Align the lengths of the wires to be connected. Insert the wires fully into the connector.

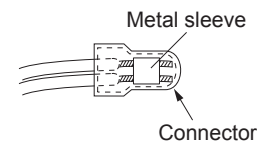

Fig.1-1-5

d) As shown in Fig.1-1-6, use the crimping tool to crimp the metal sleeve at the center position. Be sure to crimp fully to the complete closure of the tool.

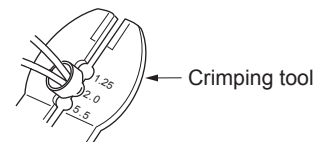

Fig.1-1-6

e) Check the four points noted in Fig.1-1-7.

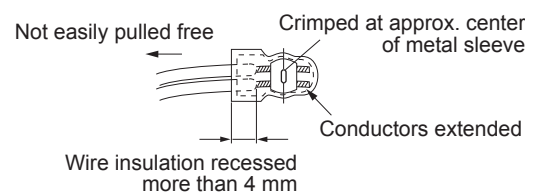

Fig.1-1-7

1.1.2 Safety Check after Servicing

Examine the area surrounding the repaired location for damage or deterioration. Observe that screws, parts and wires have been returned to original positions. Afterwards, perform the following tests and confirm the specified values in order to verify compliance with safety standards.

(1) Insulation resistance test

Confirm the specified insulation resistance or greater between power cord plug prongs and externally exposed parts of the set (RF terminals, antenna terminals, video and audio input and output terminals, microphone jacks, earphone jacks, etc.).

See table 1 below.

(2) Dielectric strength test

Confirm specified dielectric strength or greater between power cord plug prongs and exposed accessible parts of the set (RF terminals, antenna terminals, video and audio input and output terminals, microphone jacks, earphone jacks, etc.). See Fig.1-1-11 below.

(3) Clearance distance

When replacing primary circuit components, confirm specified clearance distance (d), (d') between soldered terminals, and between terminals and surrounding metallic parts. See Fig.1-1-11 below.

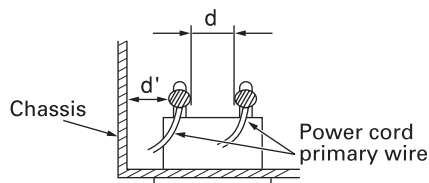

Fig.1-1-8

(4) Leakage current test

Confirm specified or lower leakage current between earth ground/power cord plug prongs and externally exposed accessible parts (RF terminals, antenna terminals, video and audio input and output terminals, microphone jacks, earphone jacks, etc.).

Measuring Method : (Power ON)

Insert load Z between earth ground/power cord plug prongs and externally exposed accessible parts. Use an AC voltmeter to measure across both terminals of load Z. See Fig.1-1-9 and following Fig.1-1-12.

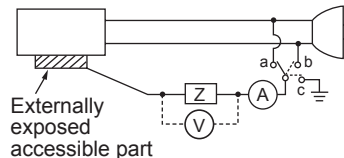

Fig.1-1-9

(5) Grounding (Class 1 model only)

Confirm specified or lower grounding impedance between earth pin in AC inlet and externally exposed accessible parts (Video in, Video out, Audio in, Audio out or Fixing screw etc.).

Measuring Method:

Connect milli ohm meter between earth pin in AC inlet and exposed accessible parts. See Fig.1-1-10 and grounding specifications.

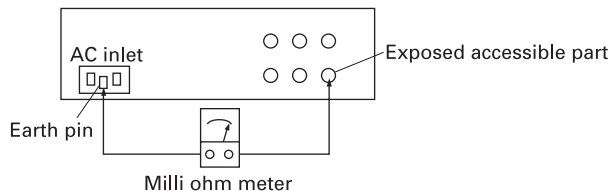

Grounding Specifications

Region	Grounding Impedance (Z)
USA & Canada	$Z \leq 0.1 \text{ ohm}$
Europe & Australia	$Z \leq 0.5 \text{ ohm}$

Fig.1-1-10

AC Line Voltage	Region	Insulation Resistance (R)	Dielectric Strength	Clearance Distance (d), (d')
100 V	Japan	$R \geq 1 \text{ M}\Omega/500 \text{ V DC}$	AC 1 kV 1 minute	$d, d' \geq 3 \text{ mm}$
100 to 240 V			AC 1.5 kV 1 minute	$d, d' \geq 4 \text{ mm}$
110 to 130 V	USA & Canada	$1 \text{ M}\Omega \leq R \leq 12 \text{ M}\Omega/500 \text{ V DC}$	AC 1 kV 1 minute	$d, d' \geq 3.2 \text{ mm}$
110 to 130 V	Europe & Australia	$R \geq 10 \text{ M}\Omega/500 \text{ V DC}$	AC 3 kV 1 minute (Class II)	$d \geq 4 \text{ mm}$
200 to 240 V			AC 1.5 kV 1 minute (Class I)	$d' \geq 8 \text{ mm (Power cord)}$ $d' \geq 6 \text{ mm (Primary wire)}$

Fig.1-1-11

AC Line Voltage	Region	Load Z	Leakage Current (i)	a, b, c
100 V	Japan		$i \leq 1 \text{ mA rms}$	Exposed accessible parts
110 to 130 V	USA & Canada		$i \leq 0.5 \text{ mA rms}$	Exposed accessible parts
110 to 130 V 220 to 240 V	Europe & Australia		$i \leq 0.7 \text{ mA peak}$ $i \leq 2 \text{ mA dc}$	Antenna earth terminals
			$i \leq 0.7 \text{ mA peak}$ $i \leq 2 \text{ mA dc}$	Other terminals

Fig.1-1-12

NOTE :

These tables are unofficial and for reference only. Be sure to confirm the precise values for your particular country and locality.

SECTION 2 SPECIFIC SERVICE INSTRUCTIONS

2.1 BEFORE ASSEMBLY AND DISASSEMBLY

2.1.1 Precautions

1. Be sure to disconnect the power supply unit prior to mounting and soldering of parts.
2. Prior to removing a component part that needs to disconnect its connector(s) and its screw(s), first disconnect the wire(s) from the connector(s), and then remove the screw(s).
3. When connecting/disconnecting wires, pay enough attention not to damage the connectors.
4. Be careful in removing or handling the part to which some spacer or shield is attached for reinforcement or insulation.
5. When replacing chip parts (especially IC parts), first remove the solder completely to prevent peeling of the pattern.
6. Tighten screws properly during the procedures. Unless specified otherwise, tighten screws at a torque of 0.088N•m (0.9kgf•cm).

2.1.2 Assembly and disassembly

[Example]

STEP No.	PART	Fig. No.	POINT	NOTE
[1]	TOP COVER ASSEMBLY	Fig.C1	S1,2(L1)	-
[2]	UPPER ASSEMBLY (Inc. VF ASSEMBLY, SPEAKER/MONITOR)	Fig.C2-1	S2a,2(S2b),3(S2c) 2(S2d),S2e,S2c L2,CN2a,b	-
[8]	VF ASSEMBLY	Fig.C2-2	2(S8),L8,CN8a	NOTE 8a NOTE 8b

↑ (1) ↑ (2) ↑ (3) ↑ (4) ↑ (5)

(1) Order of steps in Procedure

When reassembling, preform the step(s) in the reverse order. These numbers are also used as the identification (location) No. of parts Figures.

(2) Part to be removed or installed.

(3) Fig. No. showing Procedure or Part Location.

C = CABINET
D = CAMERA AND BOARD ASSEMBLY

(4) Identification of part to be removed, unhooked, unlocked, released, unplugged, unclamped or unsoldered.

P = Spring
W = Washer
S = Screw
* = Unhook, unlock, release, unplug or unsolder.
2(S3) = 2 Screws (S3)
CN = Connector

(5) Adjustment information for installation.

2.1.3 Destination of connectors

Two kinds of double-arrows in connection tables respectively show kinds of connector/wires.

⇔ : Flat wire
↔ : Wire

[Example]

CONN. No.	CONNECTOR				Pin No.
CN2a	MAIN	CN101	⇔	MONIBW	CN761 40
CN2b	MAIN	CN103	⇔	MINIBW	CN762 10

Remove the parts marked in .

2.1.4 Disconnection of connectors (Wires)

Pull both ends of the connector in the arrow direction, remove the lock and disconnect the flat wire.

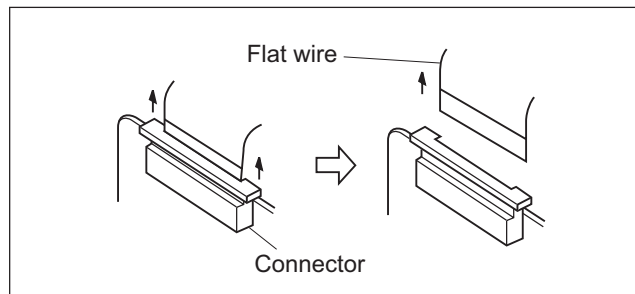

Fig.2-1-1

Extend the locks in the direction of the arrow for unlocking and then pull out the wire. After removing the wire, immediately restore the locks to their original positions because the locks are apt to come off the connector.

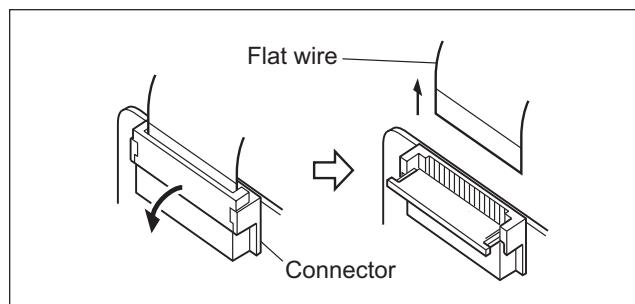

Fig.2-1-2

2.1.5 Tools required for disassembly and assembly

1	Torque driver YTU94088	2	Bit YTU94088-003
			
3	Tweezers P-895	4	Chip IC replacement jig PTS40844-2
			
5	Cleaning cloth KSMM-01		
			

Fig.2-1-3

1.Torque driver

Be sure to use to fastening the mechanism and exterior parts because those parts must strictly be controlled for tightening torque.

2.Bit

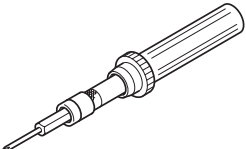
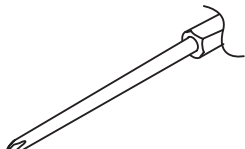
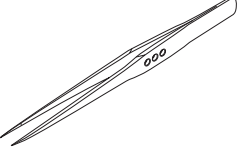
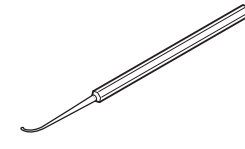
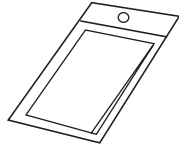
This bit is slightly longer than those set in conventional torque drivers.

3.Tweezers

To be used for removing and installing parts and wires.

4.Chip IC replacement jig

To be used for replacement of IC.

5.Cleaning cloth

Recommended cleaning cloth to wipe down the video heads, mechanism (tape transport system), optical lens surface.

2.2 ASSEMBLY AND DISASSEMBLY OF CABINET PARTS

2.2.1 Disassembly flow chart

This flowchart indicates the disassembly step for the cabinet parts and board assembly in order to gain access to item(s) to be serviced. When reassembling, perform the step(s) in reverse order.

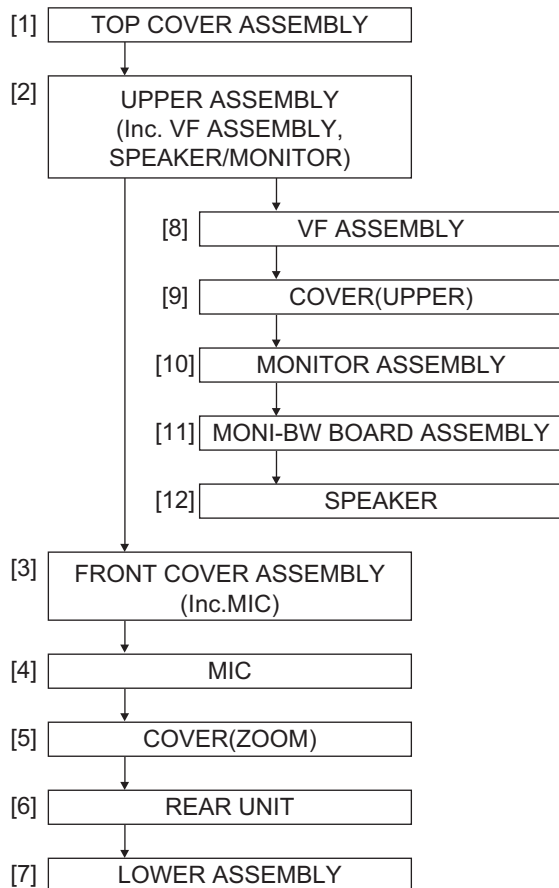

2.2.2 Disassembly method

STEP No.	PART	Fig. No.	POINT	NOTE
[1]	TOP COVER ASSEMBLY	Fig.C1	S1,2(L1)	-
[2]	UPPER ASSEMBLY (Inc. VF ASSEMBLY, SPEAKER/MONITOR)	Fig.C2-1	S2a,2(S2b),3(S2c) 2(S2d),S2e,S2c L2,CN2a,b	-
[8]	VF ASSEMBLY	Fig.C2-2	2(S8),L8,CN8a	NOTE 8a NOTE 8b
[9]	COVER(UPPER)	Fig.C2-3	2(S9),L9	-
/[10]	MONITOR ASSEMBLY		2(S10a),CN10a,2(S10b),L10	NOTE 10a NOTE 10b
[11]	MONI-BW BOARD ASSEMBLY	Fig.C2-4	2(S11a),2(S11b),4(S11c)	NOTE 11a
/[12]	SPEAKER		BKT(HINGE),KNOB(SLIDE)	NOTE 11b NOTE 11c
[3]	FRONT COVER ASSEMBLY / (Inc.MIC)	Fig.C3	COVER(JACK),S3,L3a,L3b CN4	NOTE 3
[4]	MIC		S4	
[5]	COVER(ZOOM)	Fig.C4	S5a,3(S5b),2(L5)	-
/[6]	REAR UNIT		CN6,S6	
/[7]	LOWER ASSEMBLY		CN7a,b,S7a,3(S7b)	

CONN. No.	CONNECTOR				Pin No.	
CN2a	MAIN	CN101	↔	MONI-BW	CN761	40
CN2b	MAIN	CN103	↔	MONI-BW	CN762	10
CN8a	MONI-BW	CN763	↔	VF ASSEMBLY	-	20
CN10a	MONI-BW	CN765	↔	BL-2.5/3.5	-	32
CN4	MAIN	CN106	↔	MIC	-	5
CN6	MAIN	CN104	↔	REAR UNIT	-	11
CN7a	MAIN	CN102	↔	JACK	CN501	22
CN7b	MAIN	CN109	↔	ZOOM UNIT	-	16

Remove the parts marked in .

NOTE 8a:

Take care not to cut the FPC wire when and after removing the VF ASSEMBLY.

NOTE 8b:

As for disassembly/assembly of [8]VF ASSEMBLY, see 2.4 ASSEMBLY AND DISASSEMBLY OF [8] VF ASSEMBLY.

NOTE 10a:

Take care not to cut the FPC when and after removing the MONITOR ASSEMBLY.

NOTE 10b:

As for disassembly/assembly of [10] MONITOR ASSEMBLY, see 2.5 ASSEMBLY AND DISASSEMBLY OF [10] MONITOR ASSEMBLY.

NOTE 11a:

Before removing the MONI-BW BOARD ASSEMBLY, check whether MEMORY CARD is inserted or not. If MEMORY CARD is inserted, pull out the MEMORY CARD before removing the MONI-BW BOARD ASSEMBLY.

NOTE 11b:

Since the SPEAKER is soldered to the MONI-BW BOARD ASSEMBLY, the SPEAKER should not be separated from the MONI-BW BOARD ASSEMBLY except when replacing the SPEAKER.

NOTE 11c:

Take care not to lose the KNOB(SLIDE). When attaching the KNOB(SLIDE), attach the KNOB(SLIDE) in a proper position.

NOTE 3:

After removing the FRONT COVER ASSEMBLY, OP BLOCK ASSEMBLY is not covered with anything. Take care not to damage the OP BLOCK ASSEMBLY when and after removing the FRONT COVER ASSEMBLY.

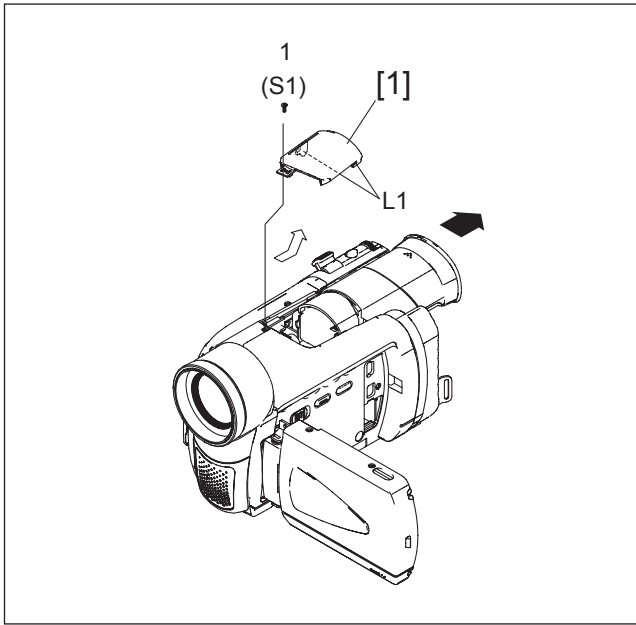

Fig.C1

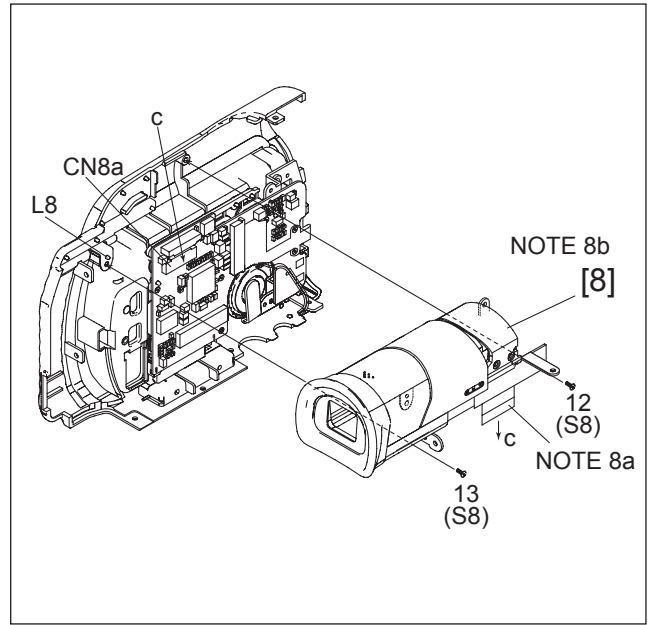

Fig.C2-2

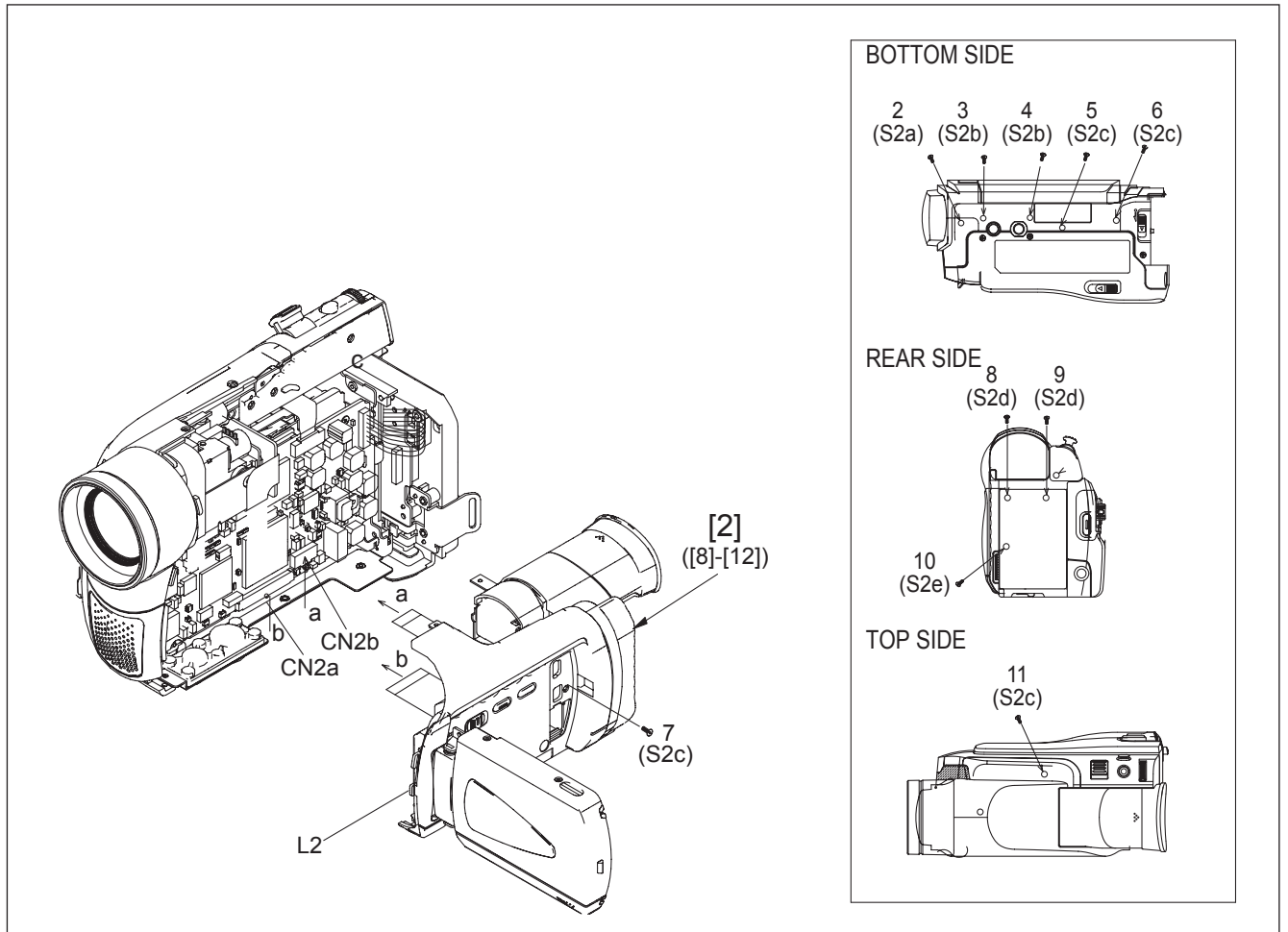

Fig.C2-1

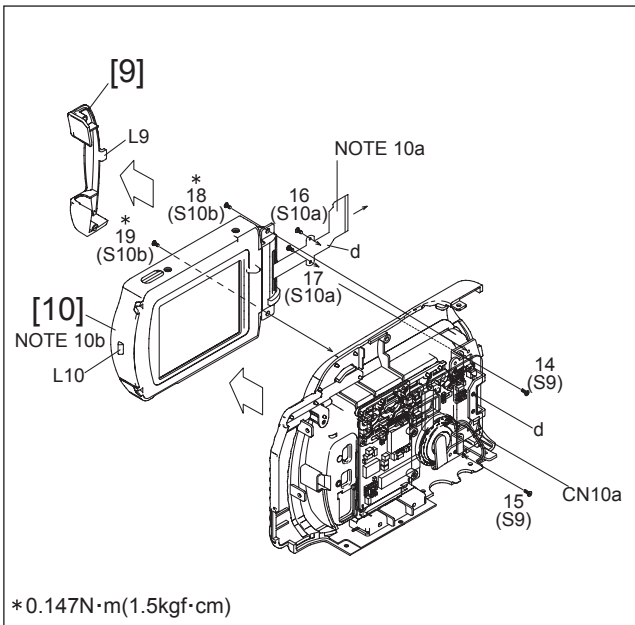

Fig.C2-3

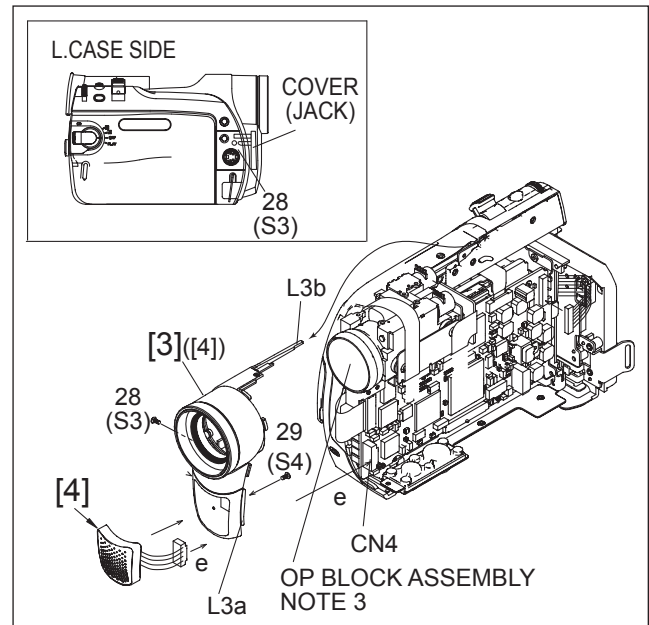

Fig.C3

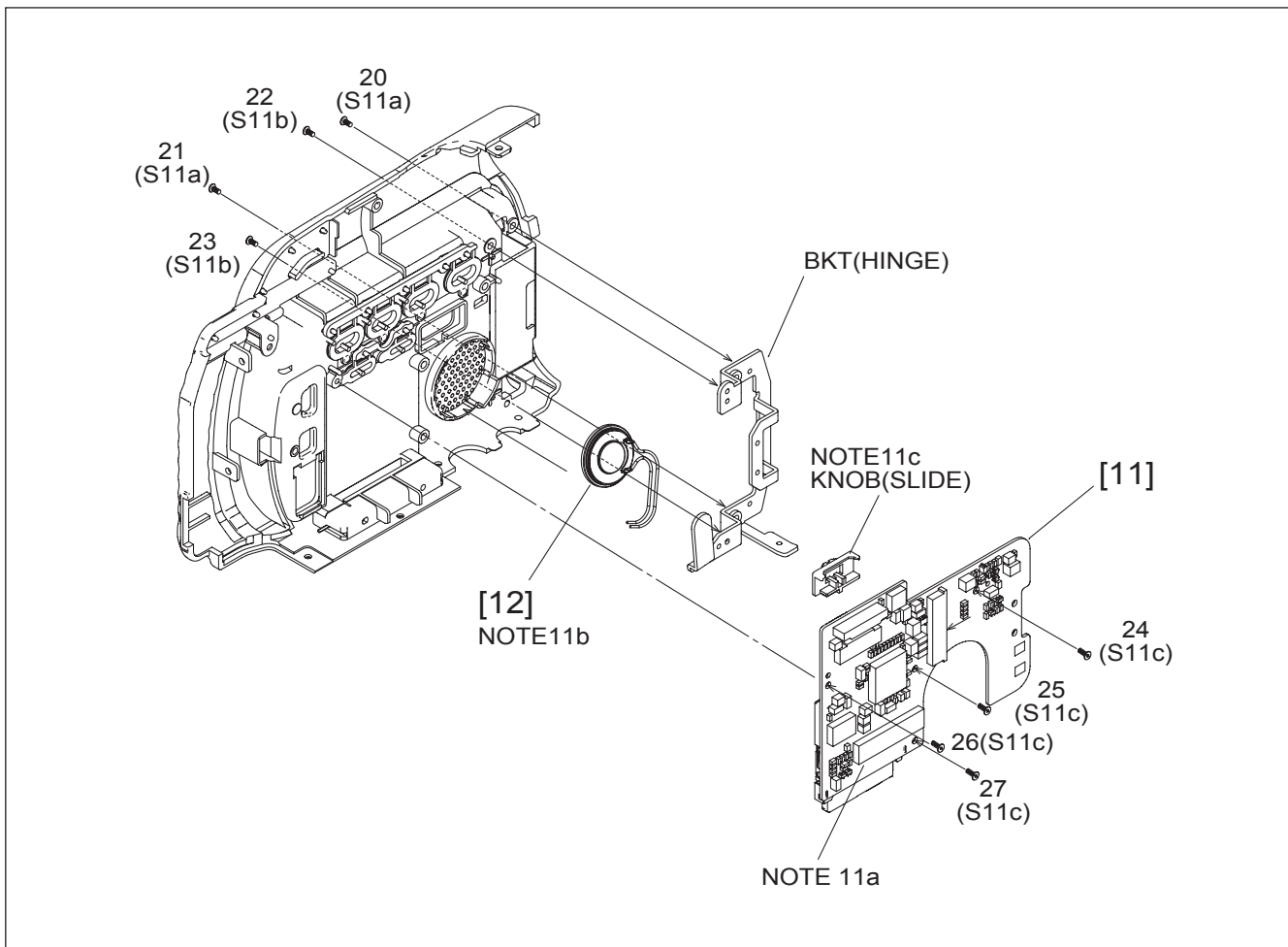

Fig.C2-4

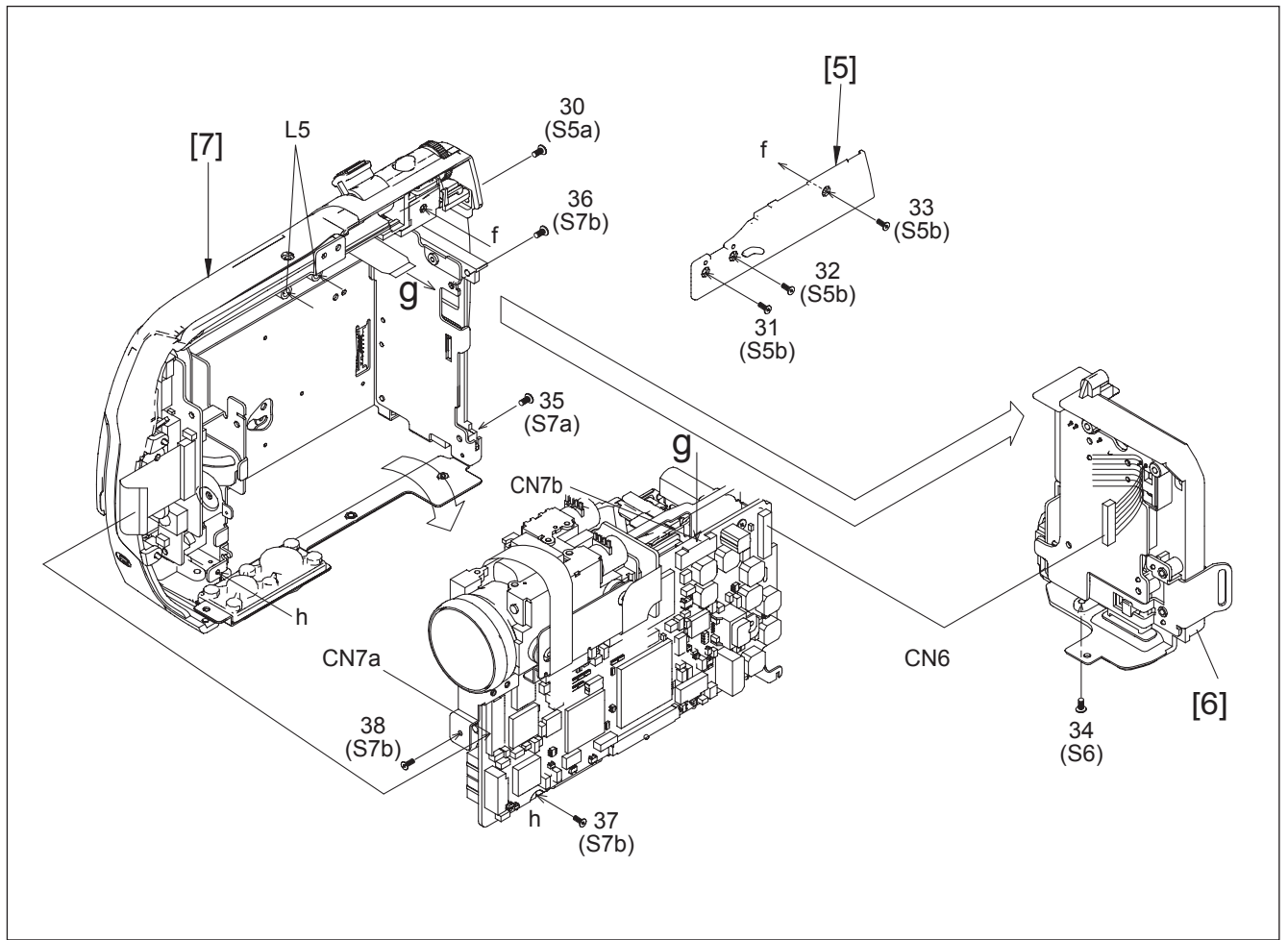

Fig.C4

2.3 ASSEMBLY AND DISASSEMBLY OF CAMERA SECTION AND BOARD ASSEMBLY

2.3.1 Disassembly flow chart

This flowchart indicates the disassembly step for the cabinet parts and board assembly in order to gain access to item(s) to be serviced. When reassembling, perform the step(s) in reverse order.

NOTE:

Please see Service Manual No. 86700 (MECHANISM ASSY).

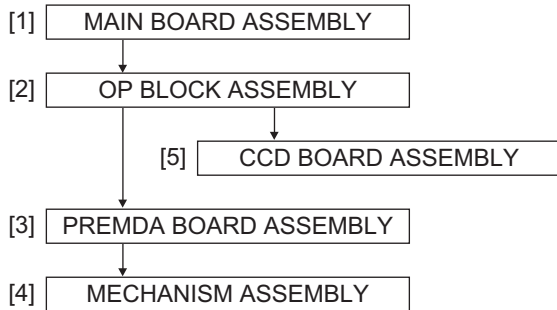

2.3.2 Disassembly method

STEP No.	PART	Fig. No.	POINT	NOTE
[1]	MAIN BOARD ASSEMBLY	Fig.D1	CN1a,b,2(S1),CN1c,d	-
[2]/[5]	OP BLOCK ASSEMBLY / CCD BOARD ASSEMBLY	Fig.D2	S2,L2	NOTE 2
[3]	PREMDA BOARD ASSEMBLY	Fig.D3	2(S3a),L3,SHIELD COVER(PR) CN3a,b,c,d,e,f,2(S3b)	-
[4]	MECHANISM ASSEMBLY		3(S4),BKT(MECHA)	-

CONN. No.	CONNECTOR		Pin No.
CN1a	MAIN	CN108 ⇄ OP BLOCK ASSEMBLY CN501	24
CN1b	MAIN	CN107 ⇄ CCD CN5001	20
CN1c	MAIN	CN111 ⇄ PREMDA CN408	40
CN1d	MAIN	CN110 ⇄ PREMDA CN401	40
CN3a	PREMDA	CN406 ⇄ SENSOR	- 16
CN3b	PREMDA	CN405 ⇄ CAPSTAN MOTOR	- 18
CN3c	PREMDA	CN404 ⇄ DRUM MOTOR	- 11
CN3d	PREMDA	CN402 ⇄ HEAD	- 8
CN3e	PREMDA	CN403 ⇄ LOADING MOTOR	- 6
CN3f	PREMDA	CN407 ⇄ ROTARY ENCODER	- 6

Remove the parts marked in .

NOTE 2:

As for disassembly/assembly of [2] OP BLOCK ASSEMBLY, see 2.6 ASSEMBLY AND DISASSEMBLY OF [2] OP BLOCK ASSEMBLY.

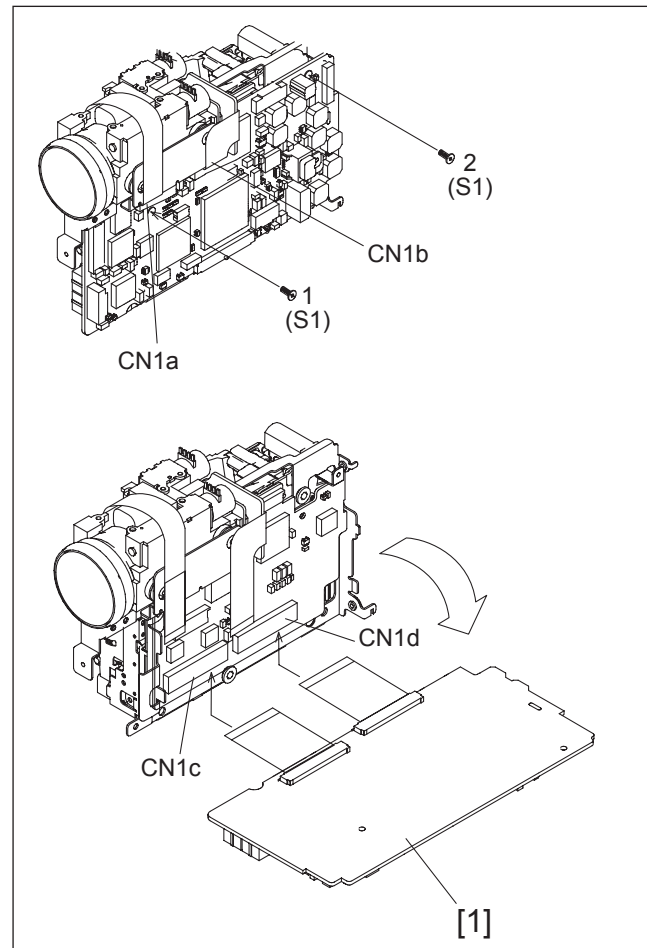

Fig.D1

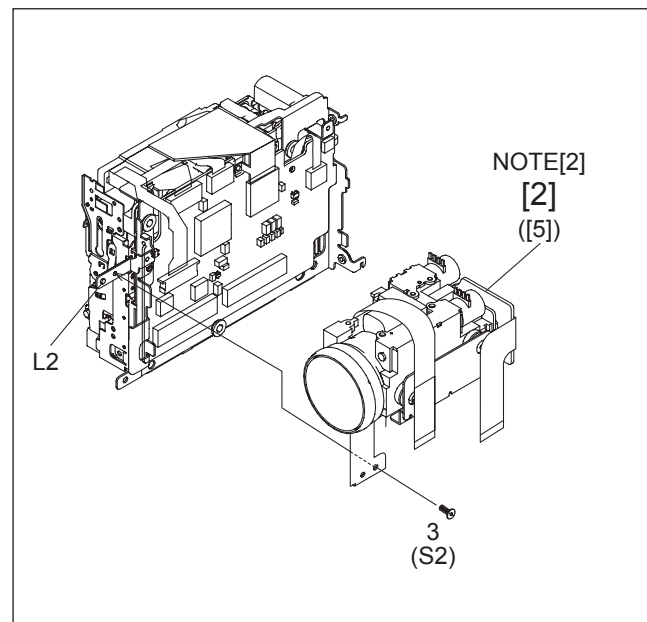

Fig.D2

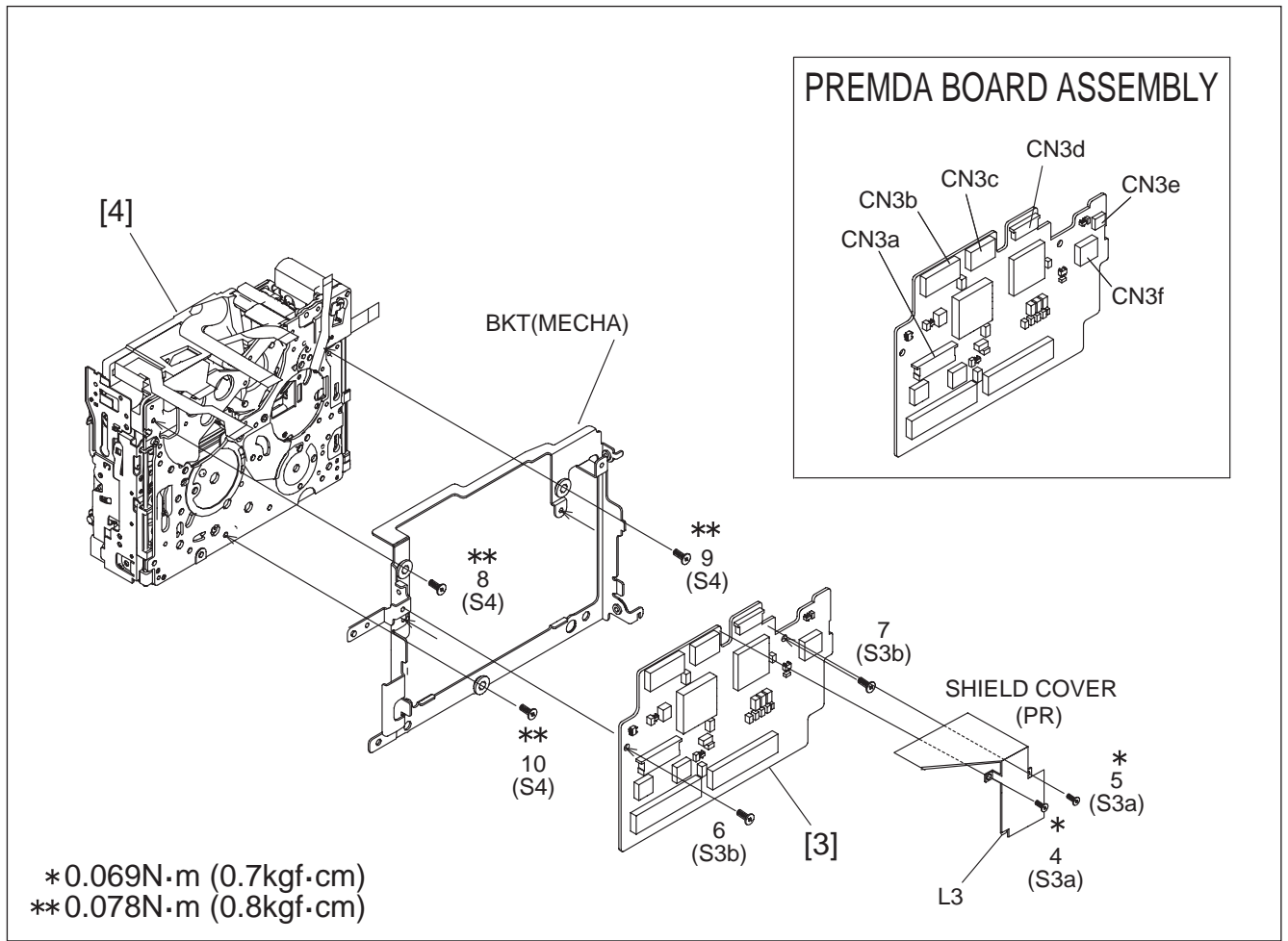

Fig.D3

2.4 ASSEMBLY AND DISASSEMBLY OF [8]VF ASSEMBLY

2.4.1 Disassembly of VF ASSEMBLY

- (1) Remove the EYE CUP.
- (2) Remove the four screws (1 to 4) and then remove the COVER (VF).
- (3) Remove the two screws (5 and 6) and then remove the FPC BOARD from the hook attaching the FPC BOARD.

NOTE 8a:

During the procedure, be careful not to damage the FPC. When attaching the SW BOARD ASSEMBLY, attach the SW BOARD ASSEMBLY so that the SW BOARD ASSEMBLY comes upwards.

- (4) Remove the four screws (7 to 10), and then pull out and remove the FPC from the VF HINGE ASSEMBLY.

NOTE 8b:

During the procedure, be careful not to damage the FPC and the SWITCH.

- (5) Remove the five screws (11 to 15).
- (6) Remove the UPPER CASE(VF) R.
- (7) Remove the UPPER CASE(VF) F and then pull out the LENS SA and the LCD UNIT ASSEMBLY with the FPC.

NOTE 8c:

In attaching the LCD UNIT ASSEMBLY, put the projections of the LCD UNIT ASSEMBLY in the slots of the BOTTOM CASE(VF). Put the STOPPER of the FPC inside the BOTTOM CASE(VF). In attaching the UPPER CASE(VF) F and the UPPER CASE(VF) R, attach the UPPER CASE(VF) F first and then the UPPER CASE(VF) R and be careful to keep the FPC inside the BOTTOM CASE(VF).

2.4.2 Disassembly of the LENS SA

- (1) Remove the LEVER(LENS).
- (2) Remove the SHEET(LENS).
- (3) Remove the LENS ASSEMBLY from the GUIDE LENS(VF).

NOTE 8d:

Be careful not to lose the SPRING(LENS).

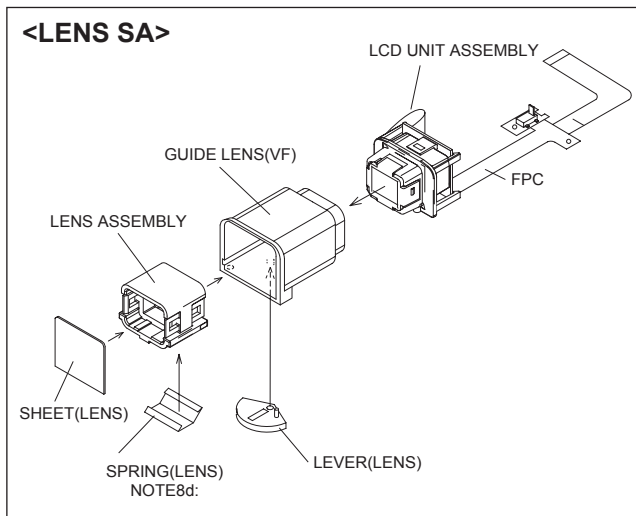

Fig.2-4-2

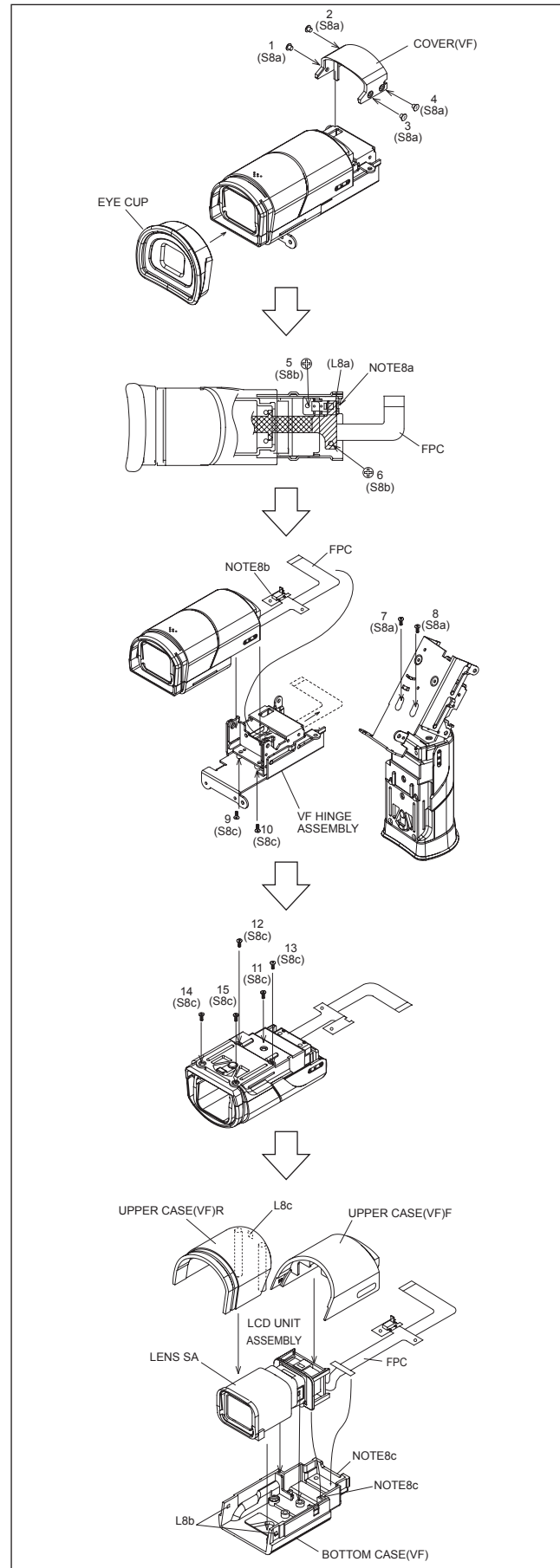

Fig.2-4-1

2.5 ASSEMBLY AND DISASSEMBLY OF [10]MONITOR ASSEMBLY (CABINET PARTS)

2.5.1 Disassembly of MONITOR ASSEMBLY (2.5 INCH)

NOTE:

Be careful in removing or handling the monitor assembly, especially not to soil or scratch the monitor screen during the disassembly procedure.

- (1) While removing the four screws (1 to 4) in numerical order and then disengaging the four hooks (L10a-L10d) in alphabetical order, open and remove the MONITOR COVER ASSEMBLY.
- (2) Remove the SENSOR BOARD ASSEMBLY from the MONITOR CASE.
- (3) Disconnect the FPC in the connectors CN10a and CN10b in this order, and then remove the MONI.HINGE ASSEMBLY.
- (4) Disconnect the FPC of the LCD MODULE from the connector CN10c.
- (5) Remove one screw (5) and then remove the BL BOARD ASSEMBLY together with the BACK LIGHT ASSEMBLY.

NOTE 10a:

It depends on the inch size of the monitor assembly whether the backlight is supplied as an assembly or as separated parts.

In replacing the backlight assembly, see the Parts List.

NOTE 10b:

Since the BACK LIGHT ASSEMBLY is soldered to the BL BOARD ASSEMBLY, the BACK LIGHT should not be separated from the BL BOARD ASSEMBLY except when replacing them.

- (6) Remove the DIFF.SHEET.
- (7) Remove the LCD FRAME together with the LCD MODULE.
- (8) Remove the SHIELD CASE.

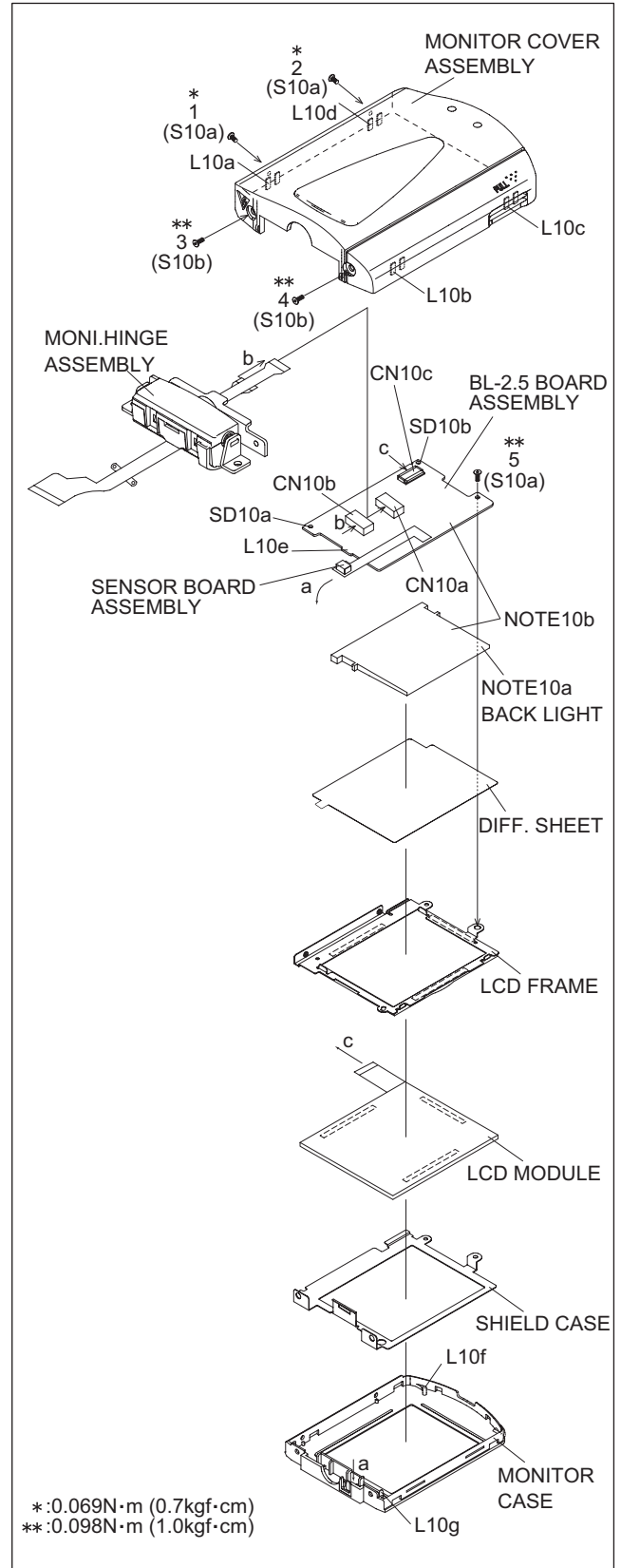

Fig.2-5-1

2.6 ASSEMBLY AND DISASSEMBLY OF [2]OP BLOCK ASSEMBLY / CCD BOARD ASSEMBLY (CAMERA SECTION AND BOARD ASSEMBLY)

2.6.1 Precautions

- (1) Take care in handling the CCD IMAGE SENSOR, OP LPF and lens components when performing maintenance etc., especially with regard to surface contamination, attached dust or scratching. If fingerprints are present on the surface they should be wiped away using either a silicon paper, clean chamois or the cleaning cloth.
- (2) The CCD IMAGE SENSOR may have been shipped with a protective sheet attached to the transmitting glass. When replacing the CCD IMAGE SENSOR, do not peel off this sheet from the new part until immediately before it is mounted in the OP BLOCK ASSEMBLY.
- (3) The orientation of the OP LPF is an important factor for installation. If there is some marking on the OP LPF, be sure to note it down before removing and to reassemble it very carefully as it was referring to the marking.

2.6.2 Disassembly of CCD BOARD ASSEMBLY and CCD BASE ASSEMBLY

- (1) Unsolder the CCD BOARD ASSEMBLY by the 14 points (SD2) and then remove it.
- (2) Remove the two screws (1, 2) and remove the CCD BASE ASSEMBLY.
- (3) Remove the SPACER.
- (4) Remove the SHEET.
- (5) Remove the OP LPF.

2.6.3 Assembly of CCD BASE ASSEMBLY and CCD BOARD ASSEMBLY

- (1) Set the OP LPF to the OP BLOCK ASSEMBLY so that the OP side touches the OP BLOCK ASSEMBLY.

NOTE 2a:

- Pay careful attention to the orientation of the OP LPF.
- (2) Set the SHEET to the OP LPF not to come off the right position.
- (3) Attach the SPACER to the OP BLOCK ASSEMBLY.
- (4) Fasten them together with the two screws (1, 2).
- (5) Set the CCD BOARD ASSEMBLY in the CCD BASE ASSEMBLY, and then solder it by the 14 points (SD2).

2.6.4 Replacement of service repair parts

The service repair parts for the OP BLOCK ASSEMBLY are as listed below.

Before replacement of these parts, remove the BRACKET (OP BLOCK ASSEMBLY) as required.

Take special care not to disconnect any of the FPC wires or cause any damage due to soldering (excessive heating).

- (1) FOCUS MOTOR
- (2) ZOOM MOTOR
- (3) IRIS MOTOR UNIT

NOTE 2b:

When replacing the FOCUS MOTOR or the ZOOM MOTOR, solder the FPC at a space of about 1 mm above the terminal pin.

NOTE 2c:

The IRIS MOTOR UNIT includes the FPC ASSEMBLY and two sensors.

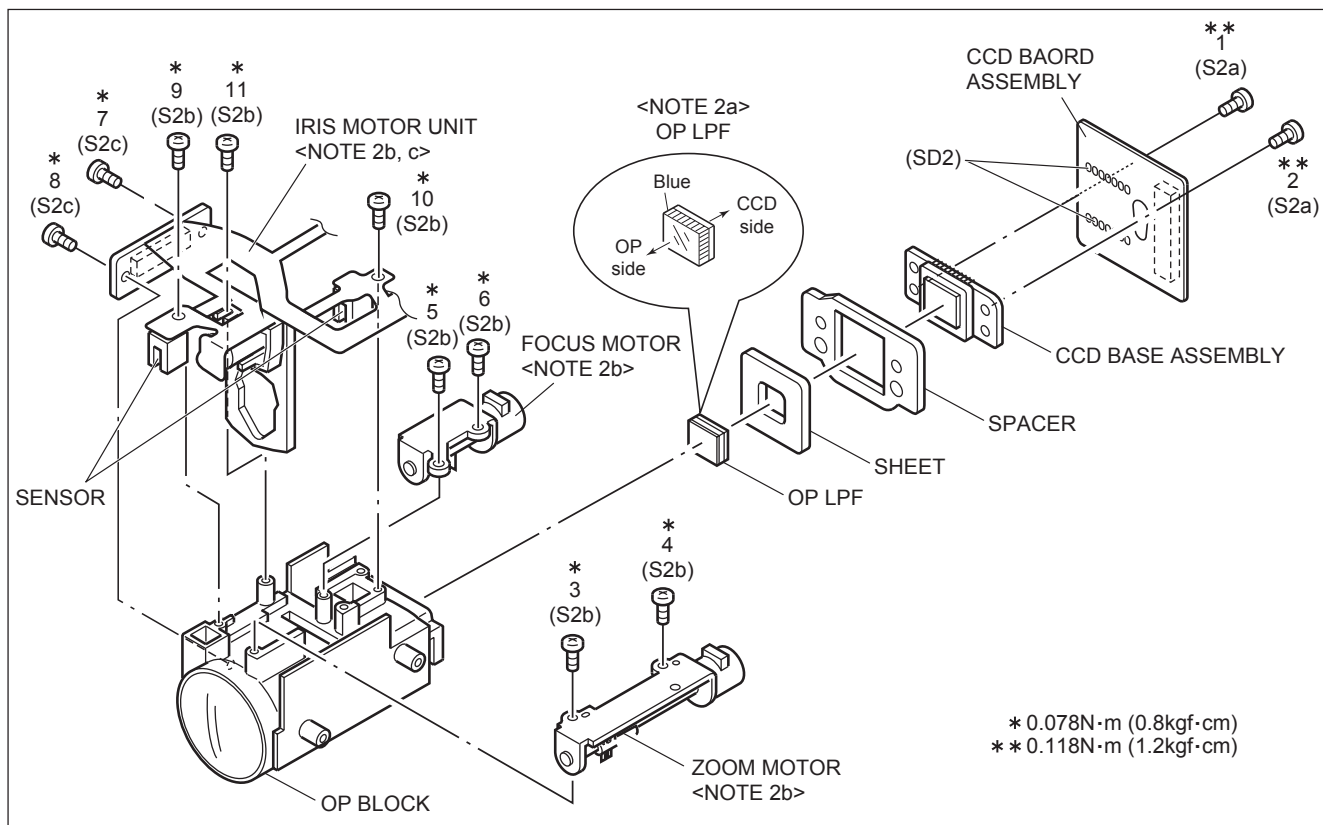

Fig.2-6-1

2.7 SERVICE NOTE

Use the following chart to manage screws

<CABINET PART>

Symbol No.	[1]	[2]	[3]	[4]	[5]	[6]	[7]	[8]	[9]	[10]	[11]	[12]	
Removing order of screw	1	2	3	4	5	6	7	8	9	10	11	12	
Place to stick screw													
Reference drawing (Fig.No.)	C1	C2-1						C2-2		C2-3		C2-4	
Screw tightening torque	I						II						

<CAMERA AND BOARD ASSEMBLY>

Symbol No.	[3]	[4]	[5]	[6]	[7]
Removing order of screw	28	29	30	31	32
Place to stick screw					
Reference drawing (Fig.No.)	C4				
Screw tightening torque	I				

<VF ASSEMBLY>

Symbol No.	[1]	[2]	[3]	[4]	[5]	[6]	[7]	[8]
Removing order of screw	1	2	3	4	5	6	7	8
Place to stick screw				*	*			
Reference drawing (Fig.No.)	2-4-1							
Screw tightening torque	IV							

<OP BLOCK ASSEMBLY>

Symbol No.	[1]	[2]	[3]	[4]	[5]	[6]	[7]	[8]	[9]	[10]	[11]
Removing order of screw	1	2	3	4	5	6	7	8	9	10	11
Place to stick screw											
Reference drawing (Fig.No.)	2-6-1										
Screw tightening torque	IV										

<NOTE>

* : Don't reuse the screw, because screw lock bond was applied to them.

·Pay careful attention to tightening torque for each screw.

I : 0.088N·m (0.9kgf·cm)

II : 0.147N·m (1.5kgf·cm)

III : 0.069N·m (0.7kgf·cm)

IV : 0.078N·m (0.8kgf·cm)

V : 0.098N·m (1.0kgf·cm)

VI : 0.118N·m (1.2kgf·cm)

<MONITOR ASSEMBLY>

Symbol No.	[1]	[2]	[3]	[4]
Removing order of screw	1	2	3	4
Place to stick screw				
Reference drawing (Fig.No.)	2-5-1			
Screw tightening torque	III			

2.8 TAKE OUT CASSETTE TAPE

NOTE :

The following procedure describes a simplified method of ejecting the cassette tape in case it is not possible to eject it, due to an electrical failure.

Be careful not to damage any of the parts or the tape when performing repairs or maintenance work.

- (1) Remove the Power Unit (battery, DC code, etc.) from the set.
- (2) Open the CASSETTE COVER.
- (3) Attach a piece of PVC TAPE at the front of the CASSETTE HOUSING ASSEMBLY.

NOTE:

This helps prevent the tape from being damaged when the CASSETTE HOUSING ASSEMBLY is moved upward at the unloading end.

- (4) Apply DC 3V to the electrode on the top surface of the LOADING MOTOR ASSEMBLY to set the MECHANISM ASSEMBLY to the EJECT mode.
Unloading end is EJECT mode.
- (5) If there is any slack tape in the tape transport system, wind it inside the DVC CASSETTE TAPE by turning the REEL DISK ASSEMBLY (SUP) from the backside of the SLIDE DECK ASSEMBLY.
- (6) Peel off the PVC TAPE and take out the DVC CASSETTE TAPE from the CASSETTE HOUSING ASSEMBLY.

NOTE:

Make sure that grease or a similar substance is not attached to the surface of the tape.

Similarly, also make sure that grease or a similar substance is not attached on the MECHANISM ASSEMBLY.

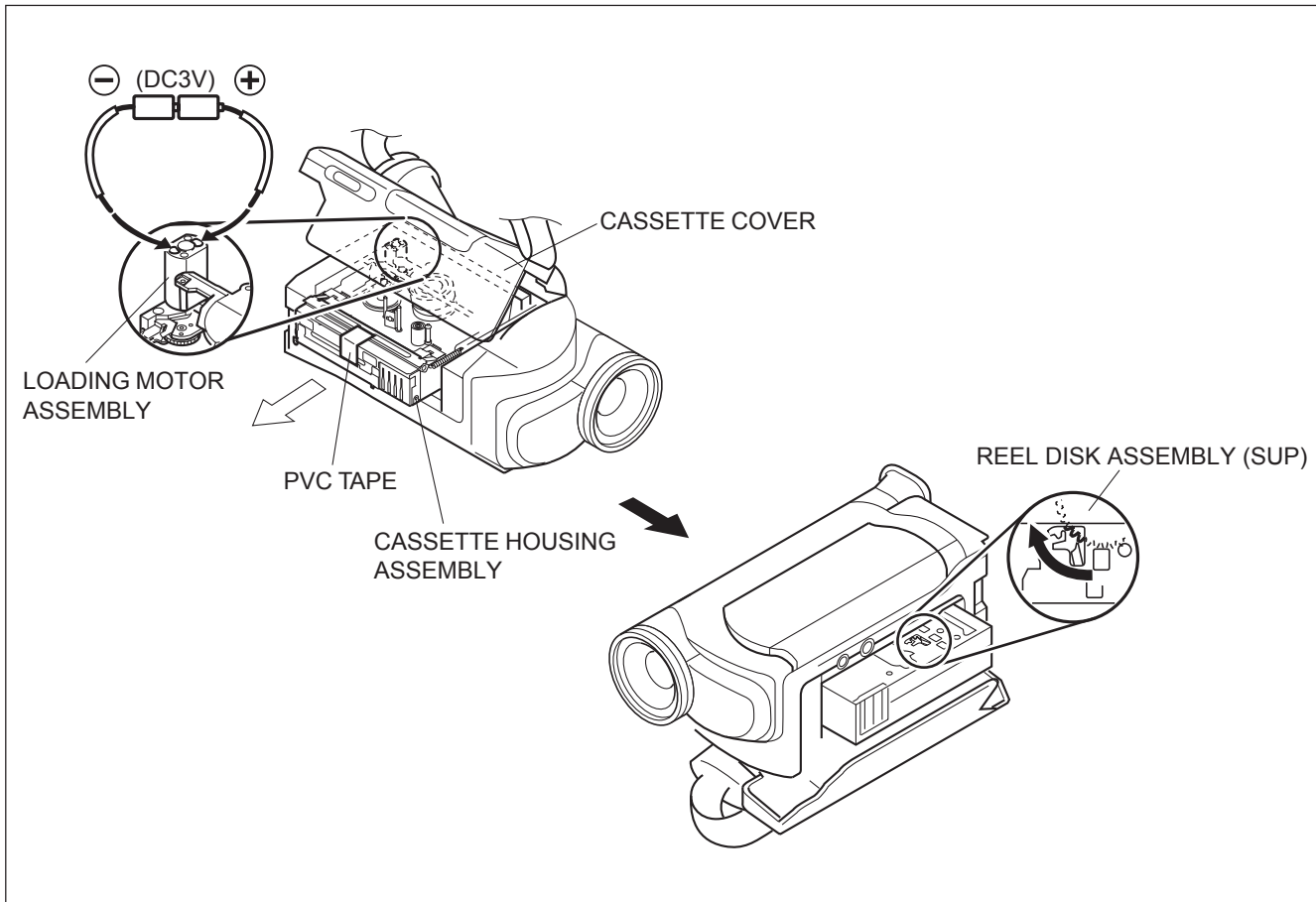

Fig.2-8-1

2.9 EMERGENCY DISPLAY

Whenever some abnormal signal is input to the syscon CPU, an error number (E01, as an example) is displayed on the LCD monitor or (in the electronic view finder).

In every error status, such the message as shown below alternately appear over and over.

- In an emergency mode, all operations except turning on/off the POWER switch are ineffectual.

Example (in case of the error number E01):

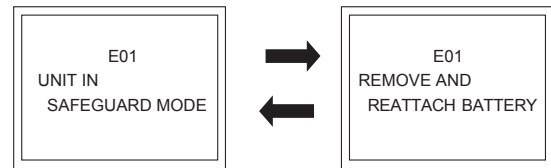

LCD display	Emergency mode	Details	Possible cause
E01	LOADING	In the case the encoder position is not shifted to the next point though the loading motor has rotated in the loading direction for 4 seconds or more. This error is defined as [E01].	<ol style="list-style-type: none"> 1. The mechanism is locked during mode shift. 2. The mechanism is locked at the mechanism loading end, because the encoder position is skipped during mechanism mode shift. 3. No power is supplied to the loading MDA.
E02	UNLOADING	In the case the encoder position is not shifted to the next point though the loading motor has rotated in the unloading direction for 4 seconds or more. This error is defined as [E02].	<ol style="list-style-type: none"> 1. The mechanism is locked during mode shift. 2. The mechanism is locked at the mechanism loading end, because the encoder position is skipped during mechanism mode shift.
E03	TU & SUP REEL FG	In the case no REEL FG is produced for 4 seconds or more in the capstan rotation mode after loading was complete, the mechanism mode is shifted to STOP with the pinch roller set off. This error is defined as [E03]. However, no REEL EMG is detected in the SLW/STILL mode.	<ol style="list-style-type: none"> 1. The idler gear does not engage with the reel disk well. 2. Though the idler gear and reel disk are engaged with each other, the tape is not wound because of overload to the mechanism. 3. No FG pulse is output from the reel sensor. 4. No power is supplied to the reel sensor. 5. Tape transport operation takes place with a cassette having no tape inside. 6. The tape slackens and no pulse is produced until the slack is taken up and the tape comes into the normal status.
E04	DRUM FG	In the case there is no DRUM FG input in the drum rotation mode for 4 seconds or more. This error is defined as [E04], and the mechanism mode is shifted to STOP with the pinch roller set off.	<ol style="list-style-type: none"> 1. The drum cannot be started or drum rotation is stopped because tape transport load is too high. <ol style="list-style-type: none"> 1) Tape tension is extremely high. 2) The tape is damaged or soiled with grease, etc. 2. The DRUM FG signal is not received by the syscon CPU. <ol style="list-style-type: none"> 1) Disconnection in the middle of the signal line. 2) Failure of the DRUM FG pulse generator (hall element). 3. No drum control voltage is supplied to the MDA. 4. No power is supplied to the DRUM MDA.
E05	-	-	-
E06	CAPSTAN FG	In the case no CAPSTAN FG is produced in the capstan rotation mode for 2 seconds or more. This error is defined as [E06], and the mechanism mode is shifted to STOP with the pinch roller set off. However, no CAPSTAN EMG is detected in the STILL/FF/REW mode.	<ol style="list-style-type: none"> 1. The CAPSTAN FG signal is not received by the syscon CPU. <ol style="list-style-type: none"> 1) Disconnection in the middle of the signal line. 2) Failure of the CAPSTAN FG pulse generator (MR element). 2. No capstan control voltage is supplied to the MDA. 4. The capstan cannot be started or capstan rotation is stopped because tape transport load is too high. <ol style="list-style-type: none"> 1) Tape tension is extremely high. (Mechanical locking) 2) The tape is damaged or soiled with grease, etc. (Tape tangling occurs, etc.)

Fig.2-9-1

SECTION 3 ADJUSTMENT

3.1 PREPARATION

(1) Precaution

This model does not contain adjustment controls (VR). General deck system, camera system and monitor system adjustment are not required. However, if MAIN board need replacement, please use original EEP ROM on to new board. Then adjustment are not required. And if parts such as the following need replacement, special computerized adjustment are required. 3.5.1 Electrical adjustment with personal computer is setup and it adjusts using a service support system. Please contact to JVC Service for detail information.

- OP BLOCK ASSEMBLY
- EEP ROM (IC1005 of MAIN board)
- MONITOR / VF ASSEMBLY

In the event of malfunction with electrical circuits, troubleshooting with the aid of proper test instruments most be done first, and then commence necessary repair, replacement and adjustment, etc.

- a) In case of wiring to chip test points for measurement, use IC clips, etc. to avoid any stress.
- b) Since connectors are fragile, carefully handle them in disconnecting and connecting.
- c) Short circuit between operation unit and DECK chassis.

(2) Required test equipment

- a) Color TV monitor.
- b) AC power adapter
- c) Oscilloscope (dual-trace type, observable 100 MHz or higher frequency)
 - It is recommended to use one observable 300 MHz or higher frequency.
- d) Digital voltmeter
- e) Frequency counter (with threshold level adjuster)
- f) Personal computer

3.2 TOOLS REQUIRED FOR ADJUSTMENT



1	Alignment tape MC-2	2	Guide driver (Hexagonal) D-770-1.27
			
3	INF adjustment lens YTU92001B	4	INF lens holder YTU94087
			
5	Camera stand YTU93079	6	Light box assembly YTU93096A
			
7	Gray scale chart YTU94133A	8	Color bar chart YTU94133C
			
9	Jig connector cable YTU93106B	10	Extension connector YTU94145C-30
			
11	Communication cable YTU93107A	12	PC cable QAM0099-005
			
13	Service support system YTU94057-67	14	Cleaning cloth KSMM-01
			

Fig.3-2-1

1. Alignment tape

To be used for check and adjustment of interchangeability of the mechanism.

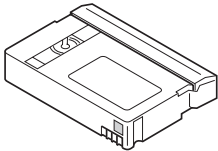
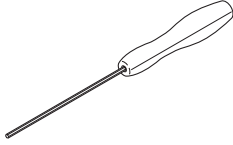
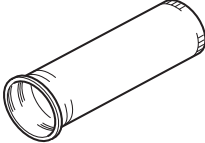
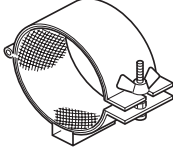
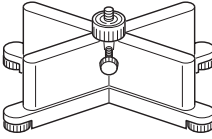
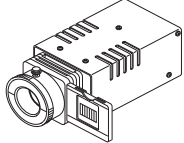
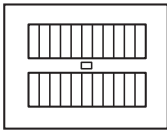
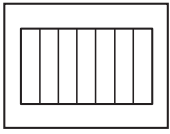
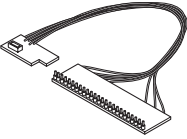
2. Guide driver (Hexagonal)

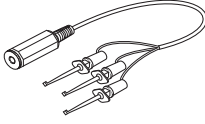
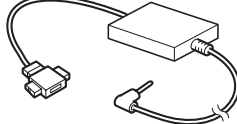
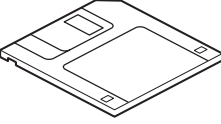
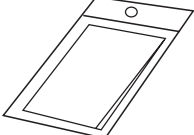
To be used to turn the guide roller to adjustment of the linearity of playback envelope.

3. INF adjustment lens

To be used for adjustment of the camera system. For the usage of the INF adjustment lens, refer to the Service Bulletin No. YA-SB-10035.

4. INF lens holder

To be used together with the Camera stand (6) for operating the Videocamera in the stripped-down condition such as the status without the exterior parts or for using commodities that are not yet conformable to the interchangeable ring. For the usage of the INF lens holder, refer to the Service Bulletin No. YA-SB-10035.

5. Camera stand

To be used together with the INF adjustment lens holder. For the usage of the Camera stand, refer to the Service Bulletin No. YA-SB-10035.

6. Light box assembly

To be used for adjustment of the camera system. For the usage of the Light box assembly, refer to the Service Bulletin No. YA-SB-10035.

7. Gray scale chart

To be used for adjustment of the camera system. For the usage of the INF adjustment lens, refer to the Service Bulletin No. YA-SB-10035.

8. Color bar chart

To be used for adjustment of the camera system. For the usage of the INF adjustment lens, refer to the Service Bulletin No. YA-SB-10035.

9. Jig connector cable

Connected to CN105 of the main board and used for electrical adjustment, etc.

NOTE:

Only some of the connectors in the JIG connector (YTU93106B) are soldered to wires.

It is desirable that you solder all the connectors to wires before using the JIG connector (YTU93106B), but you should solder only the connectors shown in the following JIG connector schematic diagram to wires because they are used in this model.

As for the details, see 3.3 JIG CONNECTOR CABLE.

10. Extension connector

Connect this extension connector to the connector of the jig connector cable for extending the cable connector.

NOTE:

removing the cover (for jig), use this extension connector triple for connecting the jig connector cable.

11. Communication Cable

Connect the Communication cable between the PC cable and Jig connector cable when performing a PC adjustment.

12. PC cable

To be used to connect the Videocamera and a personal computer with each other when a personal computer issued for adjustment.

13. Service support system

To be used for adjustment with a personal computer. Software can be downloaded also from JS-net.

14. Cleaning cloth

Recommended the Cleaning cloth to wipe down the video heads, mechanism (tape transport system), optical lens surface.

3.3 JIG CONNECTOR CABLE

Nine wires have been soldered to the JIG CONNECTOR CABLE (YTU93106B).

Solder another nine wires to the JIG CONNECTOR CABLE (YTU93106B) to use in this set.

See the JIG CONNECTOR SCHEMATIC DIAGRAM and JIG CONNECTOR BOARD to solder the nine wires.

3.3.1 JIG CONNECTOR SCHEMATIC DIAGRAM

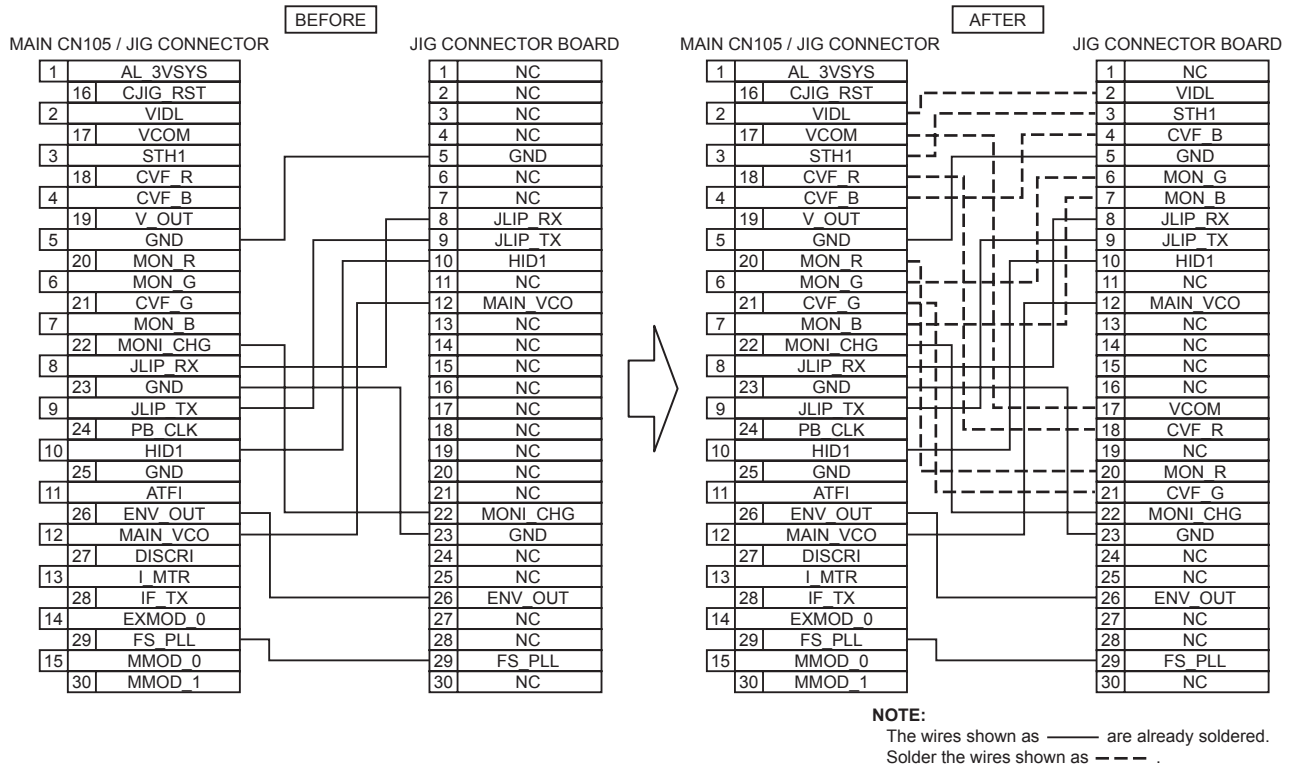

Fig.3-3-1

3.3.2 JIG CONNECTOR BOARD

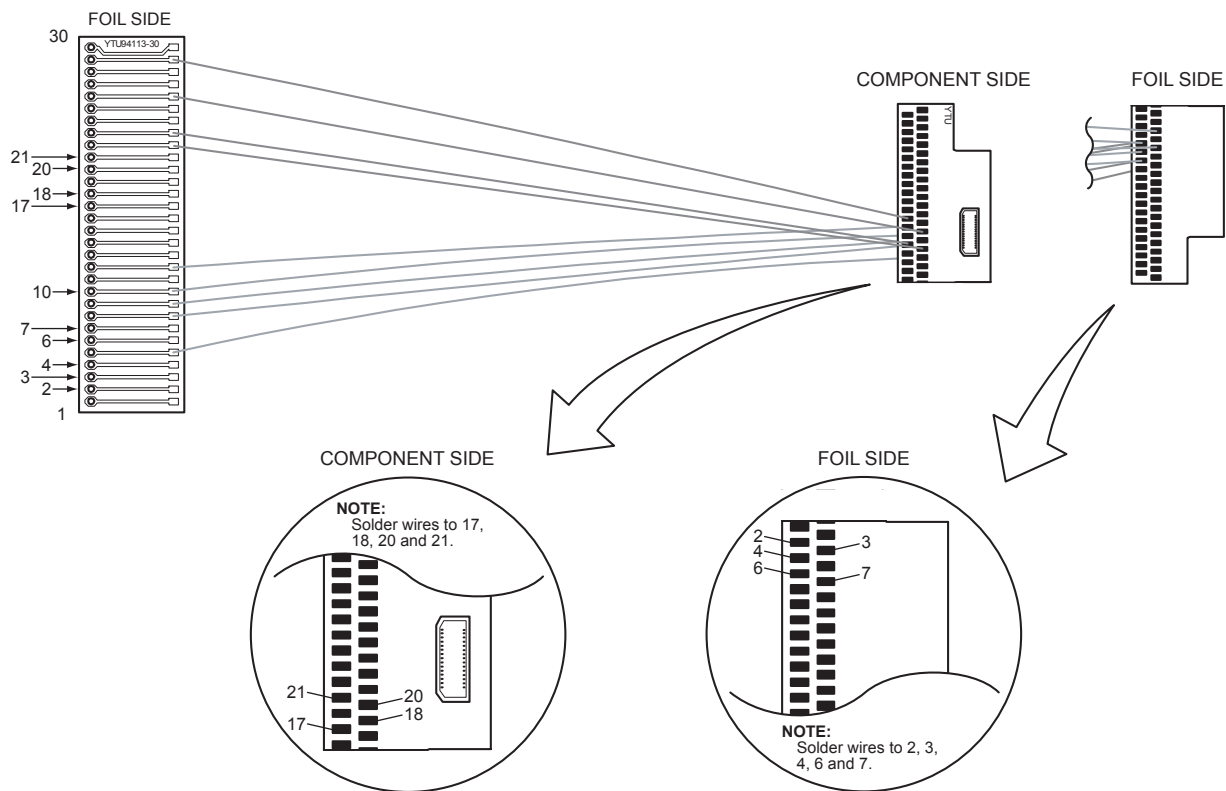

Fig.3-3-2

3.4 MECHANISM COMPATIBILITY ADJUSTMENT

3.4.1 Tape pattern check

- (1) Connect the JIG CONNECTOR CABLE to the set.
As for the connection procedure, JIG CONNECTOR BOARD and see 3.5 ELECTRICAL ADJUSTMENT.
- (2) Remove the COVER(ADJUST)
- (3) Play back the compatibility adjustment tape.
- (4) While triggering the HID1, observe the waveform of ENV_OUT.
- (5) Confirm that the waveform is free from remarkable level-down, and entirely parallel and straight.
- (6) In case any level-down is observed on the left hand side, straighten the level by turning the GUIDE ROLLER (SUP) of the POLE BASE ASSEMBLY.
In case any level-down is observed on the right hand side, however, straighten the level by turning the GUIDE ROLLER (TU) of the POLE BASE ASSEMBLY.
- (7) After adjustment, try the unloading motion once, and confirm that the waveform is flat (straight) when the tape has been played back again.
Moreover, perform readjustment as required.
- (8) When the recording has been played back again, play back the self-recording to confirm that the waveform is flat.

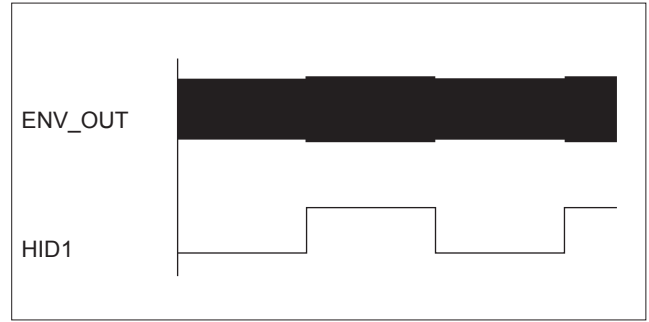

Fig.3-4-1

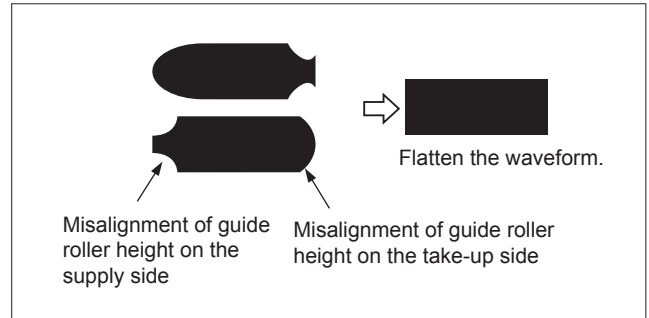

Fig.3-4-2

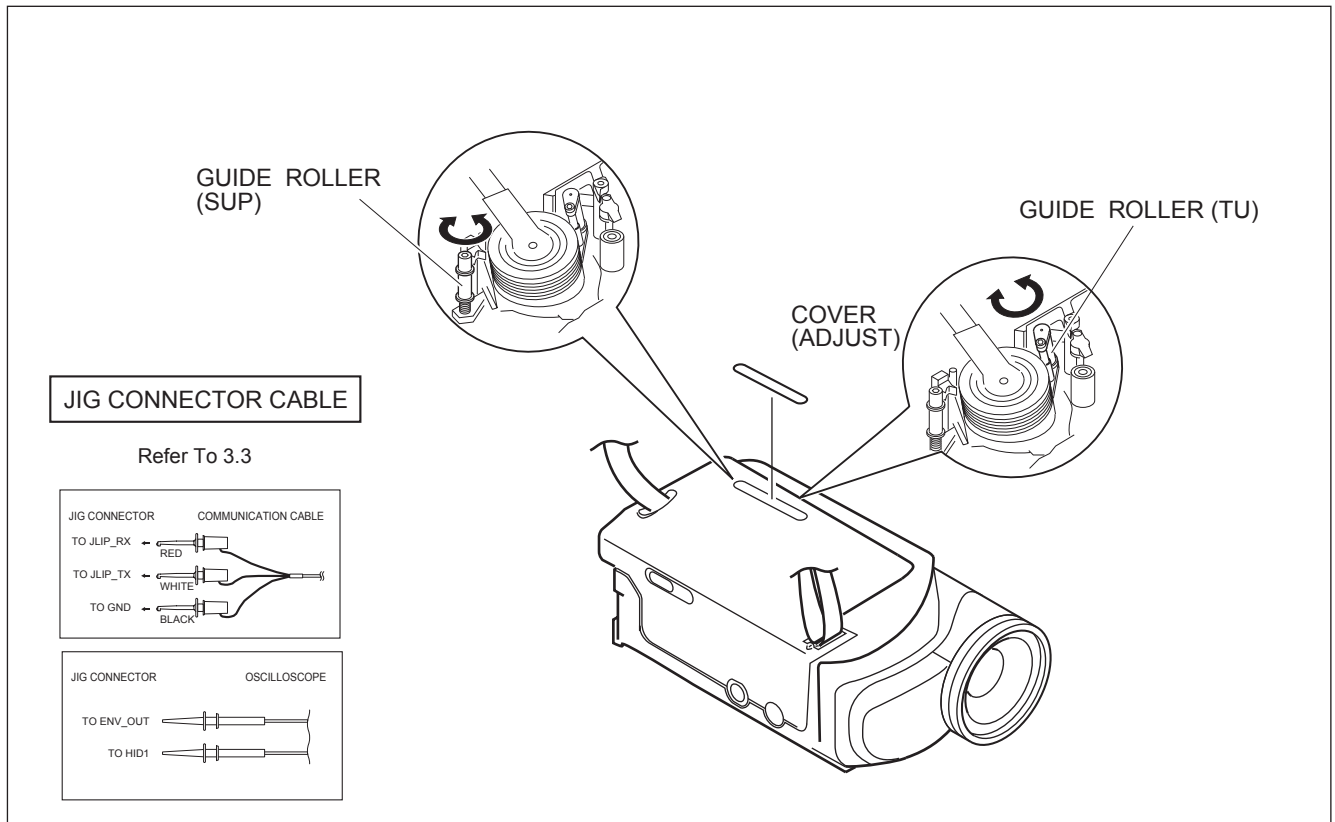

Fig.3-4-3

3.5 ELECTRICAL ADJUSTMENT

3.5.1 Electrical adjustment with personal computer

- Electrical adjustment is performed by using PERSONAL COMPUTER. As for the connection of cables, see Fig. 3-5-1. Read README.TXT file to use the software for SERVICE SUPPORT SYSTEM properly.
- Remove the COVER (JIG) to perform adjustment.

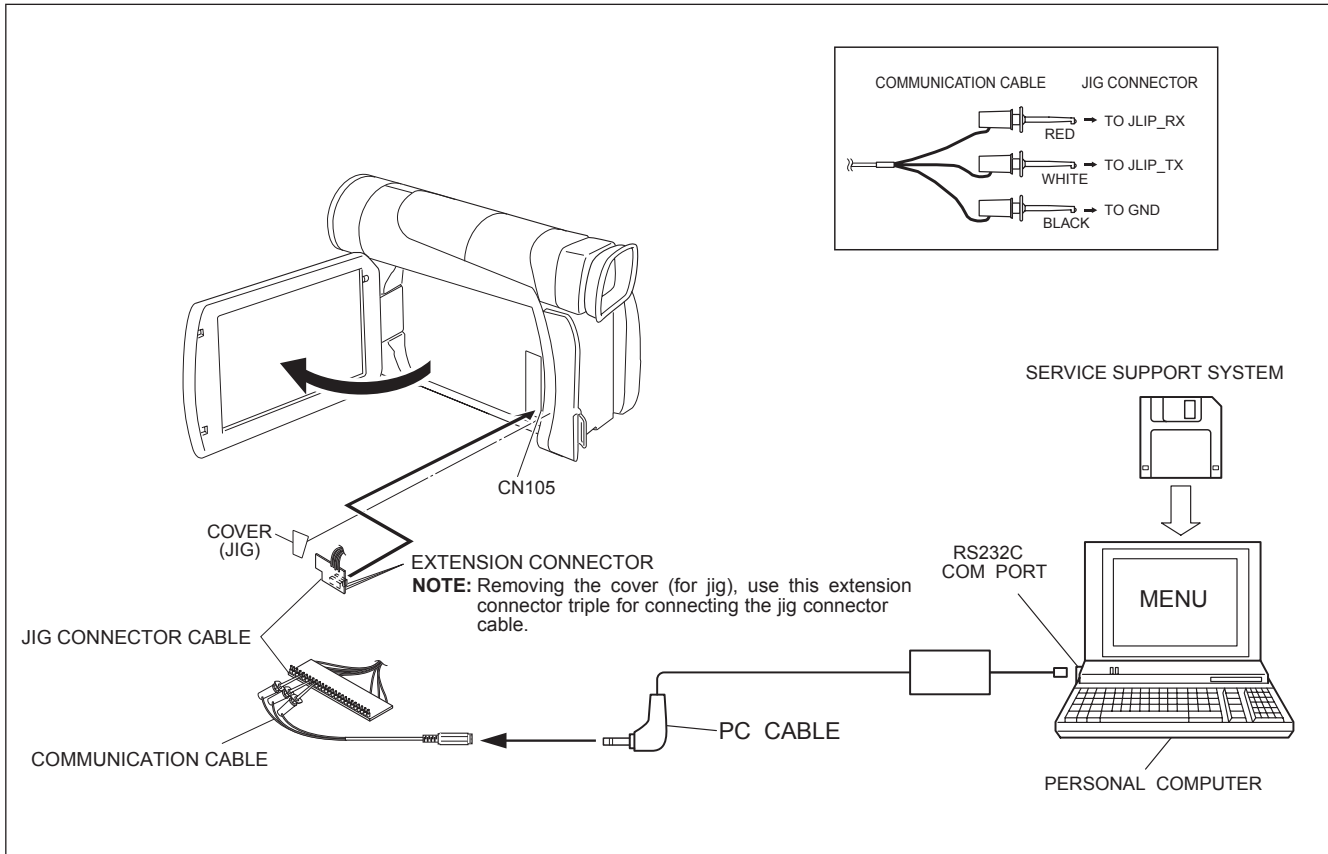

Fig.3-5-1

JVC

VICTOR COMPANY OF JAPAN, LIMITED

AV & MULTIMEDIA COMPANY CAMCORDER CATEGORY 12, 3-chome, Moriya-cho, kanagawa-ku, Yokohama, kanagawa-prefecture, 221-8528, Japan

(No.86730)



Printed in Japan
200304WPC

Free Manuals Download Website

<http://myh66.com>

<http://usermanuals.us>

<http://www.somanuals.com>

<http://www.4manuals.cc>

<http://www.manual-lib.com>

<http://www.404manual.com>

<http://www.luxmanual.com>

<http://aubethermostatmanual.com>

Golf course search by state

<http://golfingnear.com>

Email search by domain

<http://emailbydomain.com>

Auto manuals search

<http://auto.somanuals.com>

TV manuals search

<http://tv.somanuals.com>