

# JVC

## SERVICE MANUAL

### CD RECEIVER

## KD-G501, KD-G507

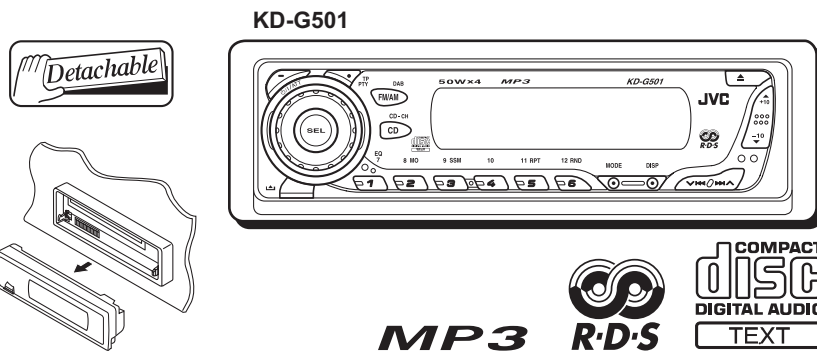

Area Suffix	
<b>KD-G501</b>	
E -----	Continental Europe
EX -----	Central Europe
<b>KD-G507</b>	
EE -----	Russian Federation

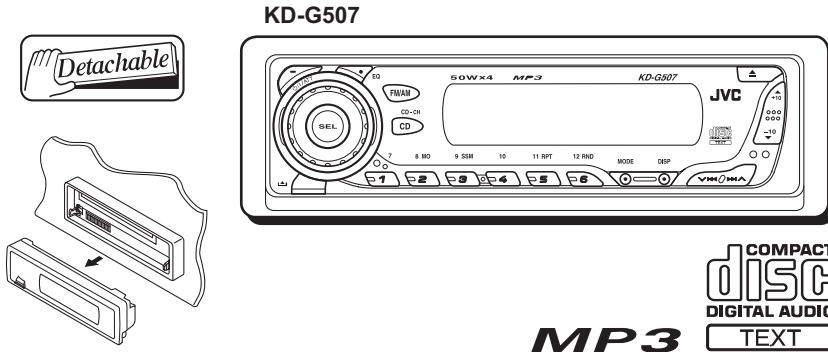

### TABLE OF CONTENTS

1	PRECAUTION.....	1-4
2	SPECIFIC SERVICE INSTRUCTIONS.....	1-6
3	DISASSEMBLY .....	1-7
4	ADJUSTMENT .....	1-25
5	TROUBLE SHOOTING.....	1-26

# SPECIFICATION

<b>AUDIO AMPLIFIER SECTION (KD-G501)</b>		
Maximum Power Output	Front	50 W per channel
	Rear	50 W per channel
Continuous Power Output (RMS)	Front	19 W per channel into 4 $\Omega$ , 40 Hz to 20 000 Hz at no more than 0.8% total harmonic distortion.
	Rear	19 W per channel into 4 $\Omega$ , 40 Hz to 20 000 Hz at no more than 0.8% total harmonic distortion.
Load Impedance		4 $\Omega$ (4 $\Omega$ to 8 $\Omega$ allowance)
Tone Control Range	Bass	$\pm 10$ dB at 100 Hz
	Treble	$\pm 10$ dB at 10 kHz
Frequency Response		40 Hz to 20 000 Hz
Signal-to-Noise Ratio		70 dB
Line-Out Level/Impedance		2.0 V/20 k $\Omega$ load (full scale)
Output Impedance		1 k $\Omega$
<b>TUNER SECTION</b>		
Frequency Range	FM	87.5 MHz to 108.0 MHz
	AM	(MW) 522 kHz to 1 620 kHz
		(LW) 144 kHz to 279 kHz
[FM Tuner]	Usable Sensitivity	11.3 dBf (1.0 $\mu$ V/75 $\Omega$ )
	50 dB Quieting Sensitivity	16.3 dBf (1.8 $\mu$ V/75 $\Omega$ )
	Alternate Channel Selectivity (400 kHz)	65 dB
	Frequency Response	40 Hz to 15 000 Hz
	Stereo Separation	30 dB
	Capture Ratio	1.5 dB
[MW Tuner]	Sensitivity	20 $\mu$ V
	Selectivity	35 dB
[LW Tuner]	Selectivity	50 $\mu$ V
<b>CD PLAYER SECTION</b>		
Type		Compact disc player
Signal Detection System		Non-contact optical pickup (semiconductor laser)
Number of channels		2 channels (stereo)
Frequency Response		5 Hz to 20 000 Hz
Dynamic Range		96 dB
Signal-to-Noise Ratio		98 dB
Wow and Flutter		Less than measurable limit
MP3 decoding format		MPEG 1/2 Audio Layer 3 Max. Bit Rate:320 Kbps
<b>GENERAL</b>		
Power Requirement	Operating Voltage	DC 14.4 V (11 V to 16 V allowance)
Grounding System		Negative ground
Allowable Operating Temperature		0°C to +40°C
Dimensions (W $\times$ H $\times$ D)	Installation Size (approx.)	182 mm $\times$ 52 mm $\times$ 150 mm
	Panel Size (approx.)	188 mm $\times$ 58 mm $\times$ 12 mm
Mass (approx.)		1.4 kg (excluding accessories)

<b>AUDIO AMPLIFIER SECTION (KD-G507)</b>		
Maximum Power Output	Front	50 W per channel
	Rear	50 W per channel
Continuous Power Output (RMS)	Front	19 W per channel into 4 $\Omega$ , 40 Hz to 20 000 Hz at no more than 0.8% total harmonic distortion.
	Rear	19 W per channel into 4 $\Omega$ , 40 Hz to 20 000 Hz at no more than 0.8% total harmonic distortion.
Load Impedance		4 $\Omega$ (4 $\Omega$ to 8 $\Omega$ allowance)
Tone Control Range	Bass	$\pm$ 10 dB at 100 Hz
	Treble	$\pm$ 10 dB at 10 kHz
Frequency Response		40 Hz to 20 000 Hz
Signal-to-Noise Ratio		70 dB
Line-Out Level/Impedance		2.0 V/20 k $\Omega$ load (full scale)
Output Impedance		1 k $\Omega$
<b>TUNER SECTION</b>		
Frequency Range	FM1/FM2	87.5 MHz to 108.0 MHz
	FM3	65.00 MHz to 74.00 MHz
	AM	(MW) 522 kHz to 1 620 kHz (LW) 144 kHz to 279 kHz
[FM Tuner]	Usable Sensitivity	11.3 dBf (1.0 $\mu$ V/75 $\Omega$ )
	50 dB Quieting Sensitivity	16.3 dBf (1.8 $\mu$ V/75 $\Omega$ )
	Alternate Channel Selectivity (400 kHz)	65 dB
	Frequency Response	40 Hz to 15 000 Hz
	Stereo Separation	30 dB
	Capture Ratio	1.5 dB
[MW Tuner]	Sensitivity	20 $\mu$ V
	Selectivity	35 dB
[LW Tuner]	Selectivity	50 $\mu$ V
<b>CD PLAYER SECTION</b>		
Type		Compact disc player
Signal Detection System		Non-contact optical pickup (semiconductor laser)
Number of channels		2 channels (stereo)
Frequency Response		5 Hz to 20 000 Hz
Dynamic Range		96 dB
Signal-to-Noise Ratio		98 dB
Wow and Flutter		Less than measurable limit
MP3 decoding format		MPEG 1/2 Audio Layer 3 Max. Bit Rate:320 Kbps
<b>GENERAL</b>		
Power Requirement	Operating Voltage	DC 14.4 V (11 V to 16 V allowance)
Grounding System		Negative ground
Allowable Operating Temperature		0°C to +40°C
Dimensions (W $\times$ H $\times$ D)	Installation Size (approx.)	182 mm $\times$ 52 mm $\times$ 150 mm
	Panel Size (approx.)	188 mm $\times$ 58 mm $\times$ 12 mm
Mass (approx.)		1.4 kg (excluding accessories)

Design and specifications are subject to change without notice.

# SECTION 1 PRECAUTION

## 1.1 Safety Precautions

 **CAUTION** Burrs formed during molding may be left over on some parts of the chassis. Therefore, pay attention to such burrs in the case of performing repair of this system.

 **CAUTION** Please use enough caution not to see the beam directly or touch it in case of an adjustment or operation check.

## 1.2 Preventing static electricity

Electrostatic discharge (ESD), which occurs when static electricity stored in the body, fabric, etc. is discharged, can destroy the laser diode in the traverse unit (optical pickup). Take care to prevent this when performing repairs.

### 1.2.1 Grounding to prevent damage by static electricity

Static electricity in the work area can destroy the optical pickup (laser diode) in devices such as CD players.

Be careful to use proper grounding in the area where repairs are being performed.

(1) Ground the workbench

Ground the workbench by laying conductive material (such as a conductive sheet) or an iron plate over it before placing the traverse unit (optical pickup) on it.

(2) Ground yourself

Use an anti-static wrist strap to release any static electricity built up in your body.

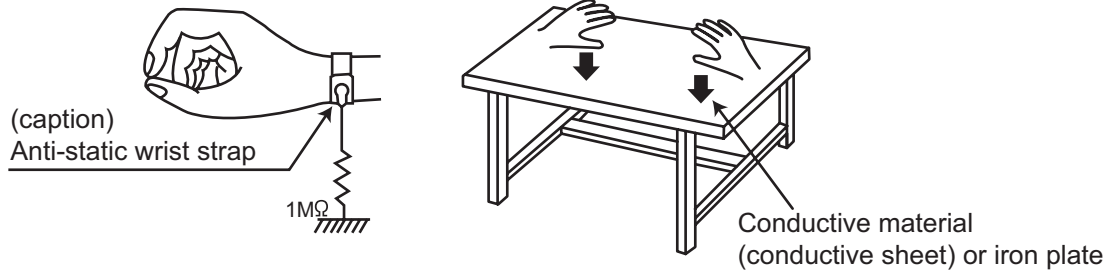

(3) Handling the optical pickup

- In order to maintain quality during transport and before installation, both sides of the laser diode on the replacement optical pickup are shorted. After replacement, return the shorted parts to their original condition. (Refer to the text.)
- Do not use a tester to check the condition of the laser diode in the optical pickup. The tester's internal power source can easily destroy the laser diode.

## 1.3 Handling the traverse unit (optical pickup)

- (1) Do not subject the traverse unit (optical pickup) to strong shocks, as it is a sensitive, complex unit.
- (2) Cut off the shorted part of the flexible cable using nippers, etc. after replacing the optical pickup. For specific details, refer to the replacement procedure in the text. Remove the anti-static pin when replacing the traverse unit. Be careful not to take too long a time when attaching it to the connector.
- (3) Handle the flexible cable carefully as it may break when subjected to strong force.
- (4) It is not possible to adjust the semi-fixed resistor that adjusts the laser power. Do not turn it.

## 1.4 Attention when traverse unit is decomposed

**\*Please refer to "Disassembly method" in the text for the CD pickup unit.**

- Apply solder to the short land before the flexible wire is disconnected from the connector on the CD pickup unit. (If the flexible wire is disconnected without applying solder, the CD pickup may be destroyed by static electricity.)
- In the assembly, be sure to remove solder from the short land after connecting the flexible wire.

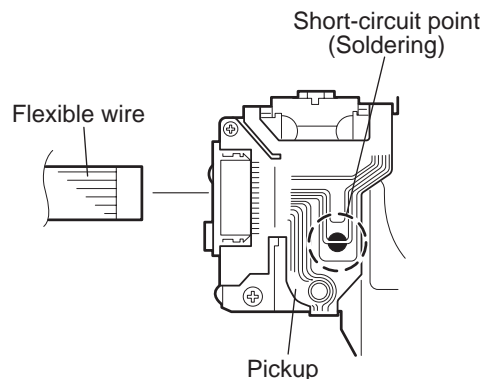

**SECTION 2**  
**SPECIFIC SERVICE INSTRUCTIONS**

This service manual does not describe SPECIFIC SERVICE INSTRUCTIONS.

## SECTION 3 DISASSEMBLY

### 3.1 Main body

#### 3.1.1 Removing the front panel assembly (See Fig.1)

- (1) Push the detach button in the lower right part of the front panel assembly and remove the front panel assembly.

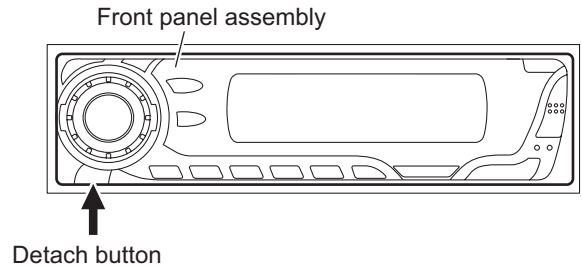

Fig.1

#### 3.1.2 Removing the bottom cover (See Fig.2)

- (1) Turn the main body up side down.
- (2) Insert a screwdriver under the joints to release the two joints **a** on the left side, two joints **b** on the right side and joint **c** on the back side of the main body, then remove the bottom cover from the main body.

#### CAUTION:

When releasing the joints using a screwdriver, do not damage the main board.

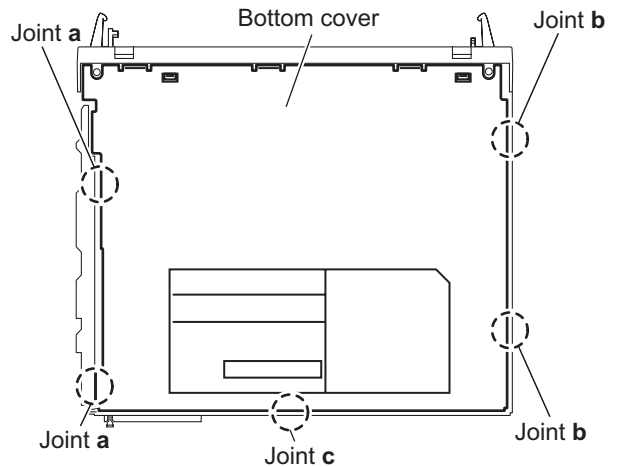

Fig.2

#### 3.1.3 Removing the front chassis assembly (See Figs.3 and 4)

- Prior to performing the following procedures, remove the front panel assembly and bottom cover.
- (1) From the both sides of the main body, remove the two screws **A** attaching the front chassis assembly. (See Fig.3.)
  - (2) From the front side of the main body, remove the two screws **B** attaching the front chassis assembly. (See Fig.4.)
  - (3) Release the two joints **d** and two joints **e** from the both sides of the main body, then remove the front chassis assembly toward the front. (See Fig.3.)

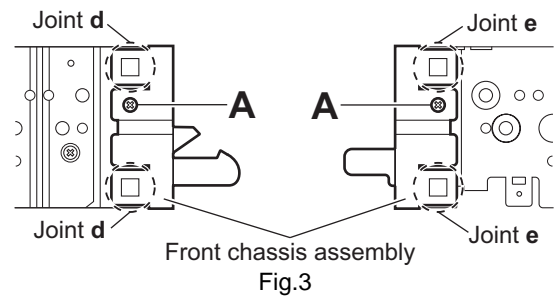

Fig.3

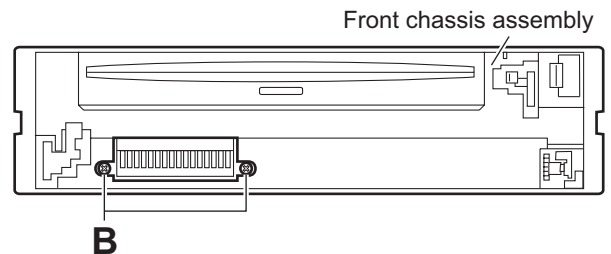

Fig.4

### 3.1.4 Removing the side panel (See Fig.5)

- Prior to performing the following procedure, remove the front panel assembly as required.
  - (1) Remove the screw **C** and two screws **D** attaching the side panel on the left side of the main body, and remove the side panel.

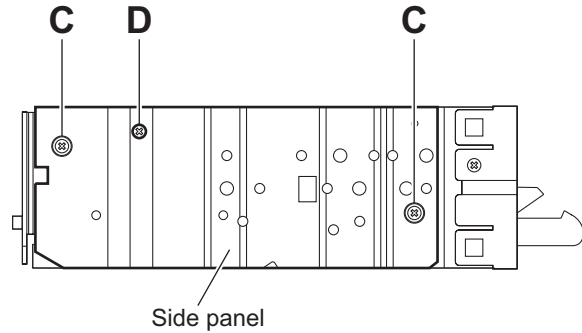

Fig.5

### 3.1.5 Removing the rear bracket (See Fig.6)

- Prior to performing the following procedure, remove the bottom cover.
  - (1) Remove the three screws **E**, screw **F** and three screws **G** attaching the rear bracket on the back side of the main body.
  - (2) Remove the rear bracket.

#### Reference:

During reassembly, before fixing the rear bracket onto the main body, insert the steering cable.(KD-G501 E)

### 3.1.6 Removing the main board (See Figs.6 and 7)

- Prior to performing the following procedure, remove the front panel assembly, bottom cover, front chassis assembly and side panel.
- Remove the rear bracket as required.
  - (1) Remove the three screws **E** attaching the rear bracket on the back side of the main board. (See fig.6.)
  - (2) Remove the two screws **H** attaching the main board. (See fig.7.)
  - (3) Disconnect the connector [CN501](#) and remove the main board. (See fig.7.)

#### Reference:

Remove the rear bracket from the main body as required. (See "3.1.5 Removing the rear bracket".)

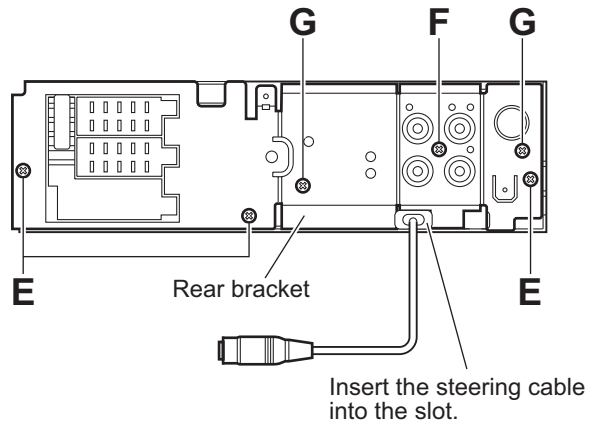

Fig.6

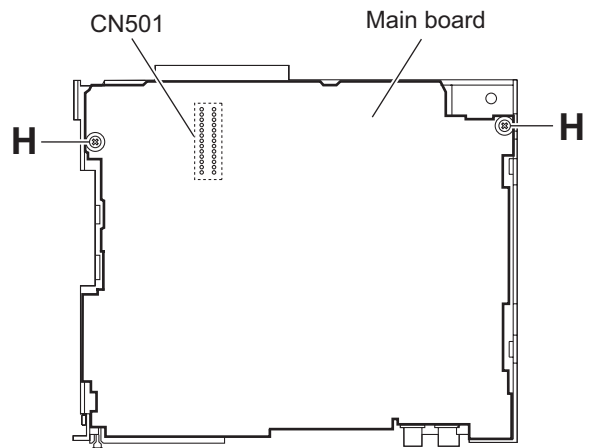

Fig.7



### 3.1.7 Removing the CD mechanism assembly (See Fig. 8)

- Prior to performing the following procedure, remove the front panel assembly, bottom cover, front chassis assembly, side panel, rear bracket and main board .
  - (1) Remove the three screws **J** attaching the CD mechanism assembly.
  - (2) Take out the CD mechanism assembly.

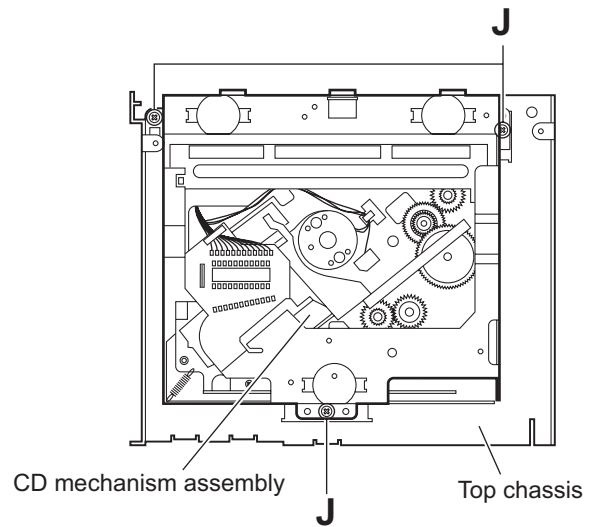

Fig.8

### 3.1.8 Removing the front board (See Figs.9 to 11)

- Prior to performing the following procedure, remove the front panel assembly.
  - (1) Remove the four screws **K** on the back side of the front panel assembly. (See Fig.9.)
  - (2) Release the ten joints **f**. (See Fig.10.)
  - (3) Release the joint **g** and take out the front board. (See Fig.11.)

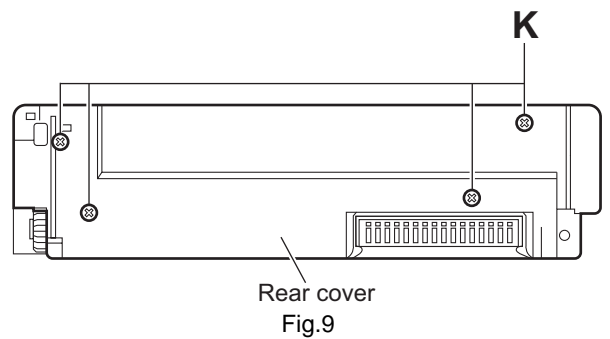

Fig.9

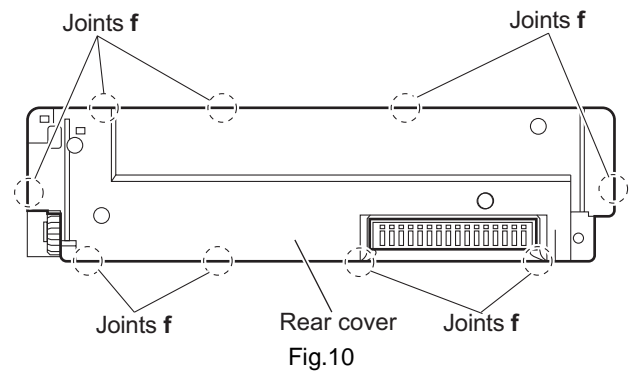

Fig.10

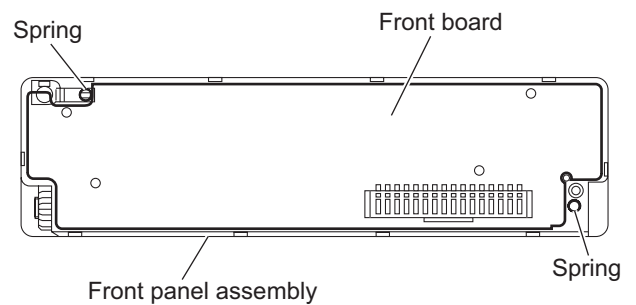

Fig.11

## 3.2 CD Mechanism Assembly

### 3.2.1 Removing the top cover (See Figs.1 and 2)

- (1) Remove the two screws **A** on the both side of the body.
- (2) Lift the front side of the top cover and move the top cover backward to release the two joints **a**.

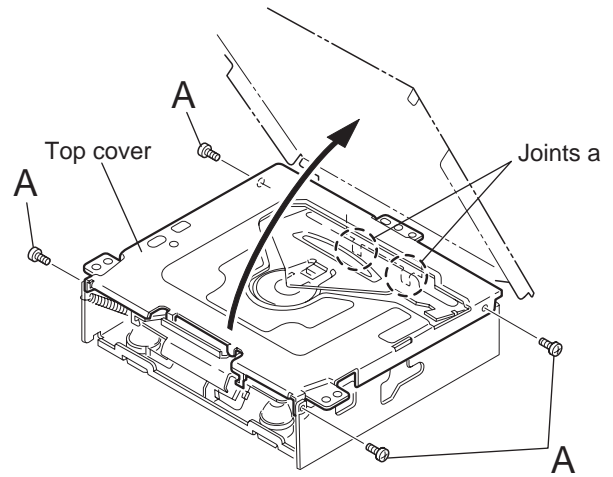

Fig.1

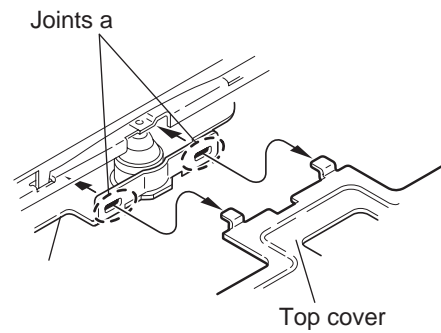

Fig.2

### 3.2.2 Removing the connector board (See Figs.3 to 5)

#### CAUTION:

Before disconnecting the flexible wire from the pickup, solder the short-circuit point on the pickup. No observance of this instruction may cause damage of the pickup.

- (1) Remove the screw **B** fixing the connector board.
- (2) Solder the short-circuit point on the connector board.
- (3) Disconnect the flexible wire from the pickup.
- (4) Move the connector board in the direction of the arrow to release the two joints **b**.
- (5) Unsolder the wire on the connector board if necessary.

#### CAUTION:

Unsolder the short-circuit point after reassembling.

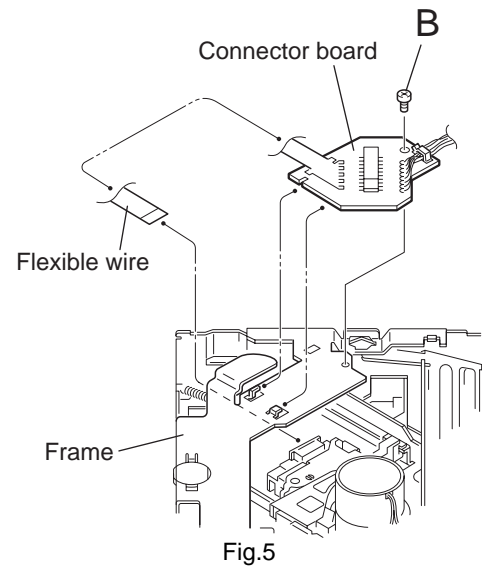
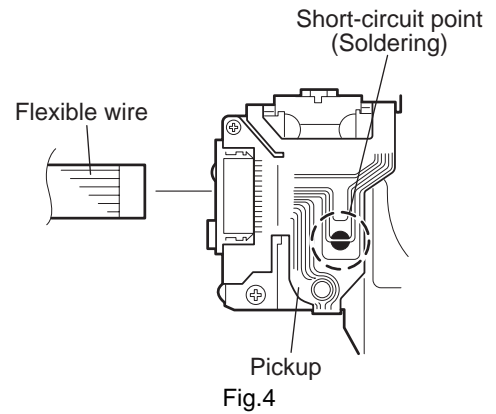
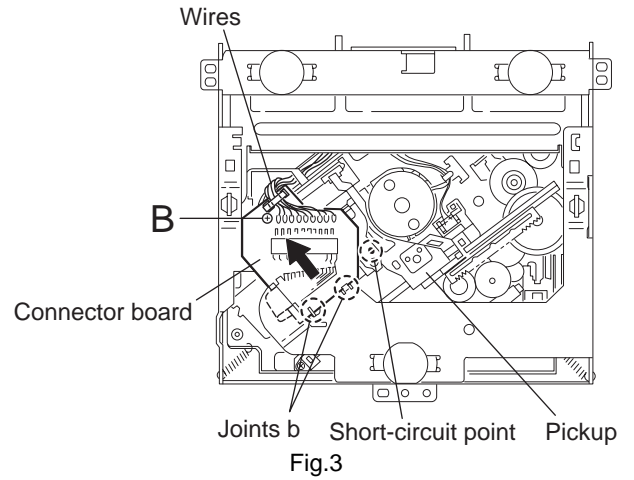

### 3.2.3 Removing the DET switch (See Figs.6 and 7)

- (1) Extend the two tabs **c** of the feed sw. holder and pull out the switch.
- (2) Unsolder the DET switch wire if necessary.

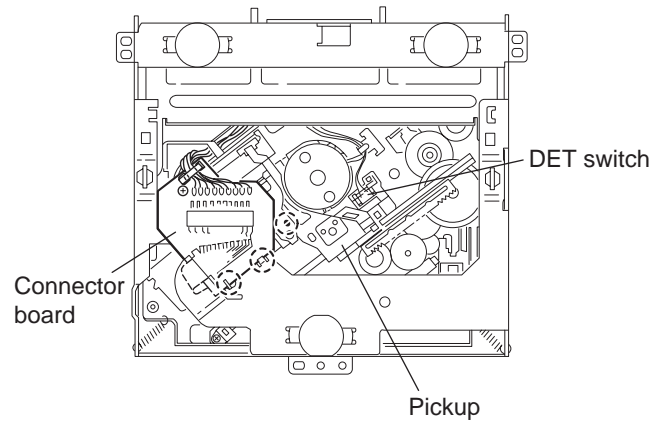

Fig.6

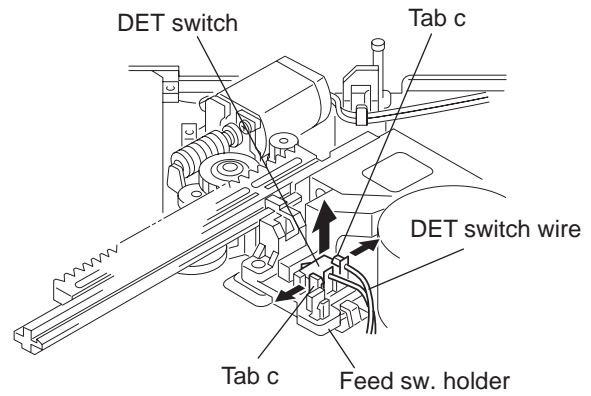

Fig.7

### 3.2.4 Removing the chassis unit (See Figs.8 and 9)

- Prior to performing the following procedure, remove the top cover and connector board.  
(1) Remove the two suspension springs (L) and (R) attaching the chassis unit to the frame.

**CAUTION:**

- The shape of the suspension spring (L) and (R) are different. Handle them with care.
- When reassembling, make sure that the three shafts on the underside of the chassis unit are inserted to the dampers certainly.

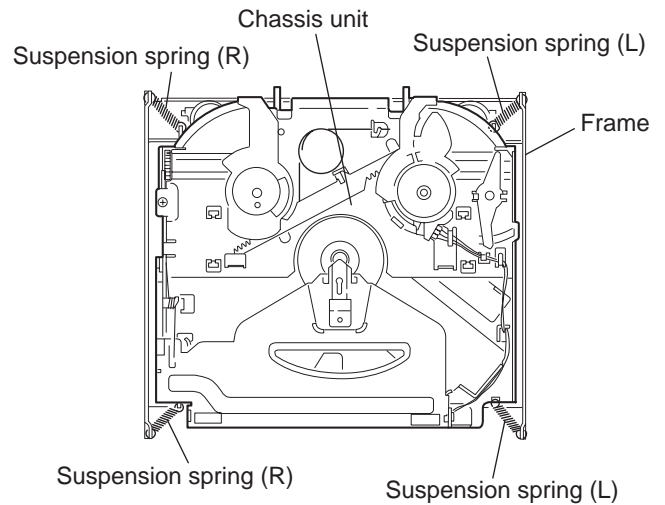

Fig.8

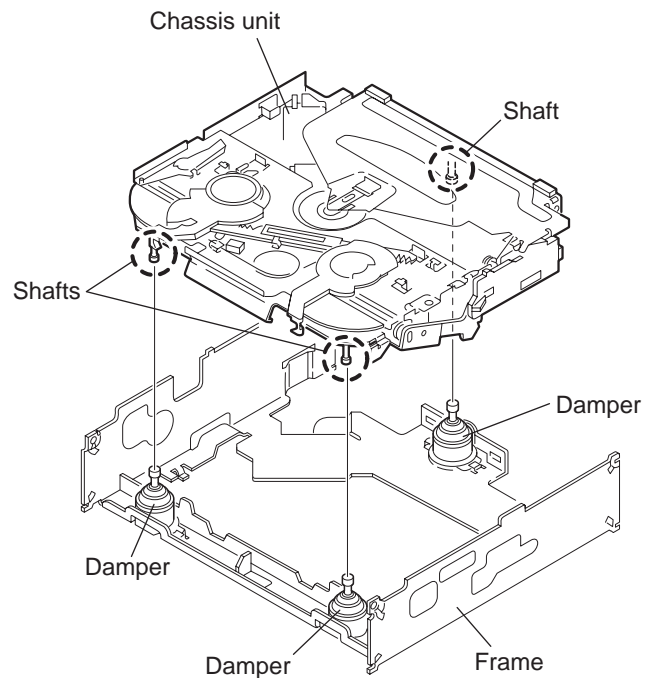
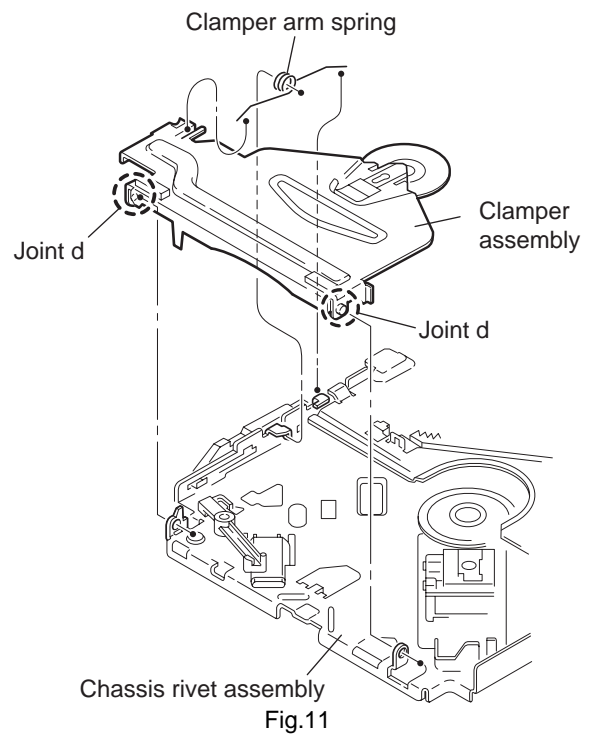
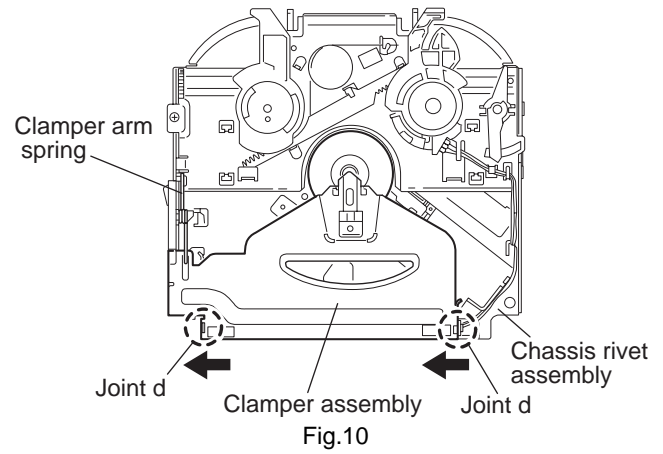

Fig.9

### 3.2.5 Removing the clamper assembly (See Figs.10 and 11)

- Prior to performing the following procedure, remove the top cover.
  - (1) Remove the clamper arm spring.
  - (2) Move the clamper assembly in the direction of the arrow to release the two joints **d**.



### 3.2.6 Removing the loading / feed motor assembly (See Figs.12 and 13)

- Prior to performing the following procedure, remove the top cover, connector board and chassis unit.
  - (1) Remove the screw **C** and move the loading / feed motor assembly in the direction of the arrow to remove it from the chassis rivet assembly.
  - (2) Disconnect the wire from the loading / feed motor assembly if necessary.

**CAUTION:**

When reassembling, connect the wire from the loading / feed motor assembly to the flame as shown in Fig.12.

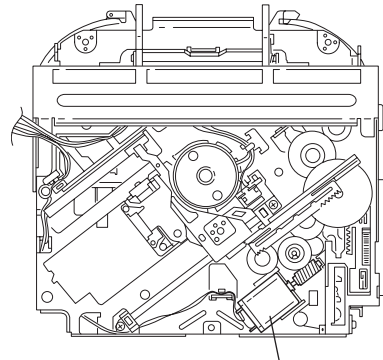

Loading / feed motor assembly  
Fig.12

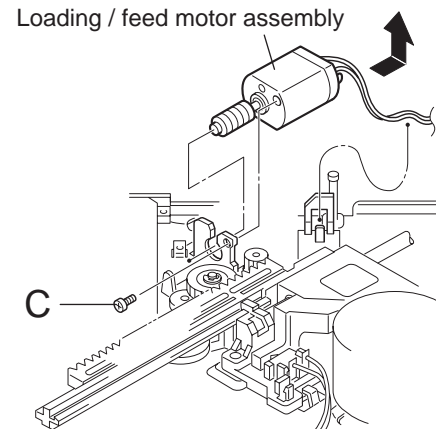

Fig.13

### 3.2.7 Removing the pickup unit (See Figs.14 to 18)

- Prior to performing the following procedure, remove the top cover, connector board and chassis unit.
  - (1) Remove the screw **D** and pull out the pu. shaft holder from the pu. shaft.
  - (2) Remove the screw **E** attaching the feed sw. holder.
  - (3) Move the part **e** of the pickup unit upward with the pu. shaft and the feed sw. holder, then release the joint **f** of the feed sw. holder in the direction of the arrow. The joint **g** of the pickup unit and the feed rack is released, and the feed sw. holder comes off.
  - (4) Remove the pu. shaft from the pickup unit.
  - (5) Remove the screw **F** attaching the feed rack to the pickup unit.

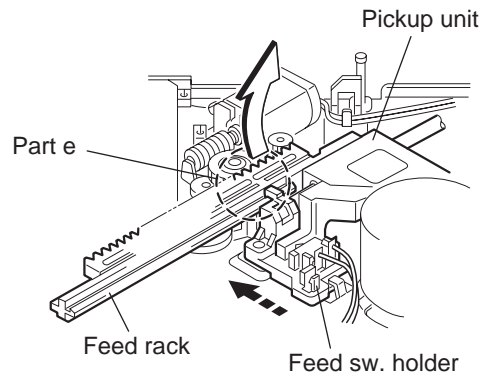

Fig.15

### 3.2.8 Reattaching the pickup unit (See Figs.14 to 17)

- (1) Reattach the feed rack to the pickup unit using the screw **F**.
- (2) Reattach the feed sw. holder to the feed rack while setting the joint **g** to the slot of the feed rack and setting the part **f** of the feed rack to the switch of the feed sw. holder correctly.
- (3) As the feed sw. holder is temporarily attached to the pickup unit, set to the gear of the joint **g** and to the bending part of the chassis (joint **h**) at a time.

**CAUTION:**

Make sure that the part **i** on the underside of the feed rack is certainly inserted to the slot **j** of the change lock lever.

- (4) Reattach the feed sw. holder using the screw **E**.
- (5) Reattach the pu. shaft to the pickup unit. Reattach the pu. shaft holder to the pu. shaft using the screw **D**.

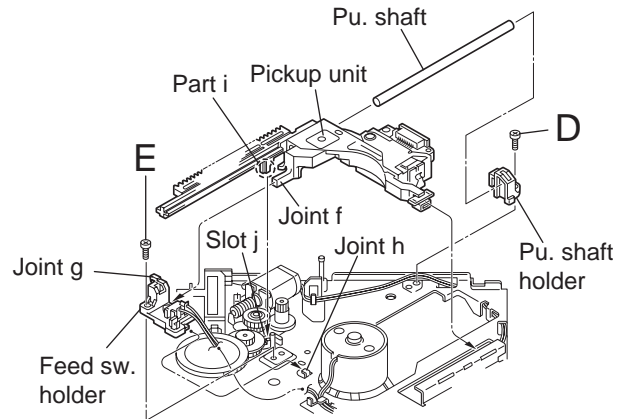

Fig.16

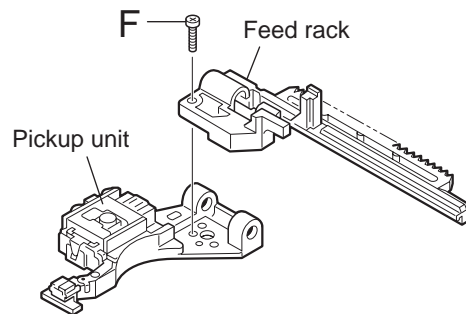

Fig.17

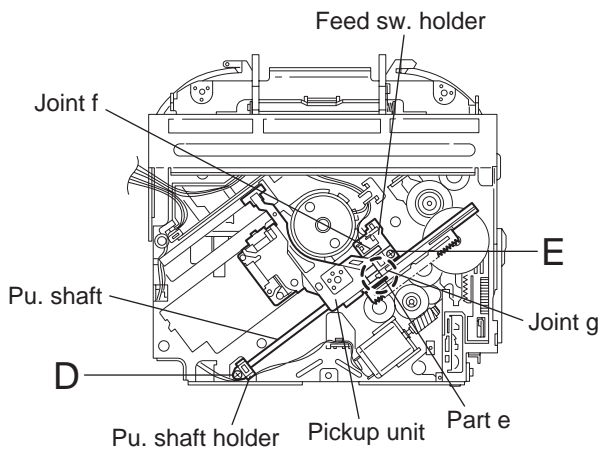

Fig.14

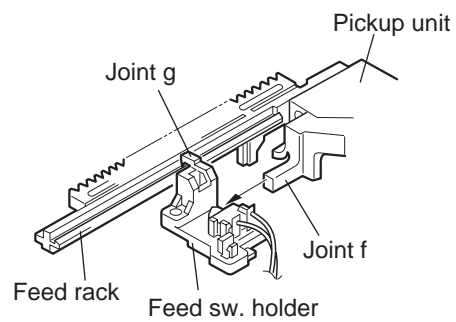

Fig.18



### 3.2.9 Removing the trigger arm (See Figs.19 and 20)

- Prior to performing the following procedure, remove the top cover, connector board and clamper unit.
- (1) Turn the trigger arm in the direction of the arrow to release the joint k and pull out upward.

**CAUTION:**

When reassembling, insert the part m and n of the trigger arm into the part p and q at the slot of the chassis rivet assembly respectively and join the joint k at a time.

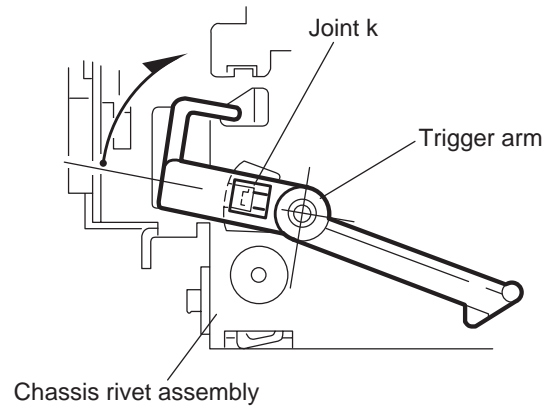

Fig.19

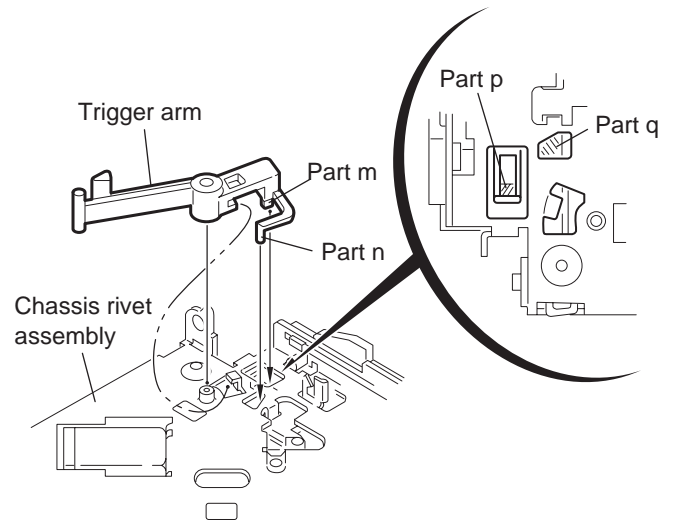

Fig.20

### 3.2.10 Removing the top plate assembly (See Fig.21)

- Prior to performing the following procedure, remove the top cover, connector board, chassis unit, and clamper assembly.
- (1) Remove the screw H.
- (2) Move the top plate assembly in the direction of the arrow to release the two joints r.
- (3) Unsolder the wire marked s if necessary.

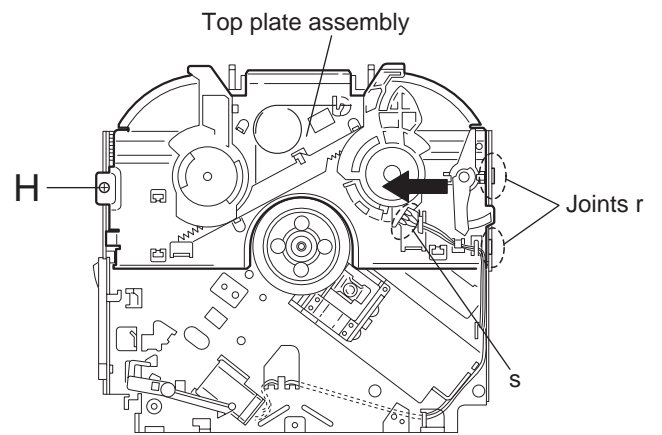

Fig.21

### 3.2.11 Removing the mode sw. / select lock arm (See Figs.22 and 23)

- Prior to performing the following procedure, remove the top plate assembly.
  - (1) Bring up the mode sw. to release from the link plate (joint **t**) and turn in the direction of the arrow to release the joint **u**.
  - (2) Unsolder the wire of the mode sw. marked **s** if necessary.
  - (3) Turn the select lock arm in the direction of the arrow to release the two joints **v**.
  - (4) The select lock arm spring comes off the select lock arm at the same time.

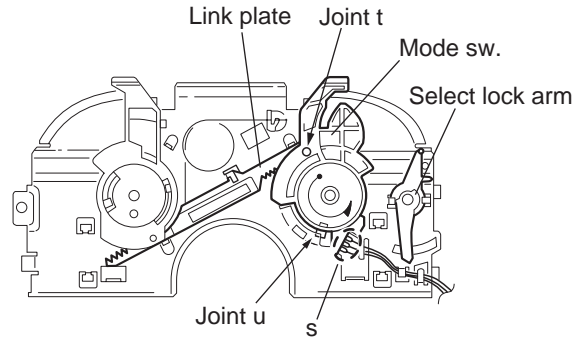

Fig.22

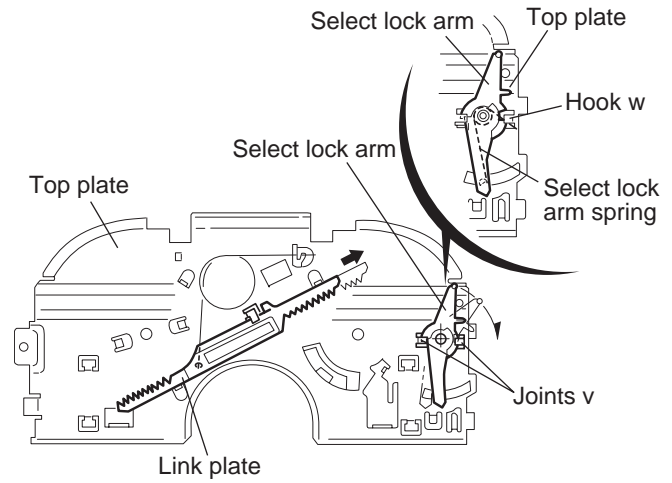

Fig.23

### 3.2.12 Reassembling the mode sw. / select lock arm (See Figs.24 to 26)

#### REFERENCE:

Reverse the above removing procedure.

- (1) Reattach the select lock arm spring to the top plate and set the shorter end of the select lock arm spring to the hook w on the top plate.
- (2) Set the other longer end of the select lock arm spring to the boss x on the underside of the select lock arm, and join the select lock arm to the slots (joint v). Turn the select lock arm as shown in the figure.
- (3) Reattach the mode sw. while setting the part t to the first peak of the link plate gear, and join the joint u.

#### CAUTION:

When reattaching the mode sw., check if the points y and z are correctly fitted and if each part operates properly.

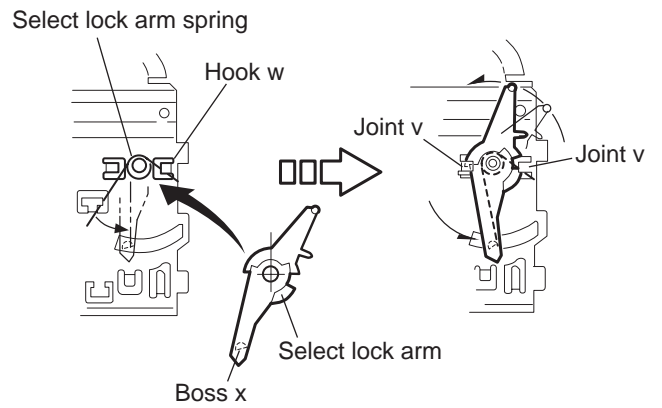

Fig.24

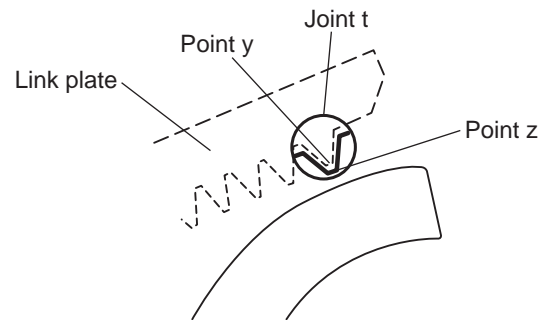

Fig.25

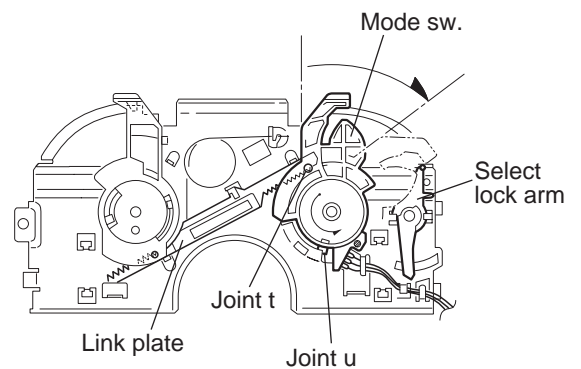

Fig.26

**3.2.13 Removing the select arm R / link plate**  
**(See Figs.27 and 28)**

- Prior to performing the following procedure, remove the top plate assembly.

(1) Bring up the select arm R to release from the link plate (joint a') and turn as shown in the figure to release the two joints b' and joint c'.

(2) Move the link plate in the direction of the arrow to release the joint d'. Remove the link plate spring at the same time.

**REFERENCE:**

Before removing the link plate, remove the mode sw..

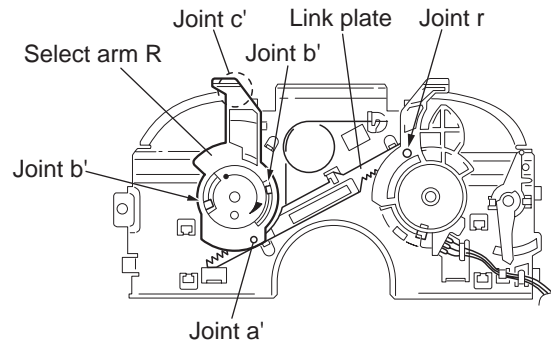

Fig.27

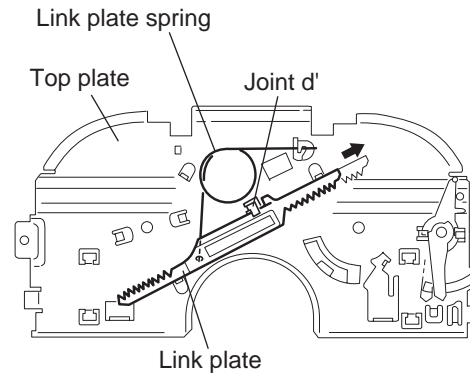

Fig.28

**3.2.14 Reattaching the Select arm R / link plate**  
**(See Figs.29 and 30)**

**REFERENCE:**

Reverse the above removing procedure.

- (1) Reattach the link plate spring.
- (2) Reattach the link plate to the link plate spring while joining them at joint d'.
- (3) Reattach the joint a' of the select arm R to the first peak of the link plate while joining the two joints b' with the slots. Then turn the select arm R as shown in the figure. The top plate is joined to the joint c'.

**CAUTION:**

When reattaching the select arm R, check if the points e' and f' are correctly fitted and if each part operates properly.

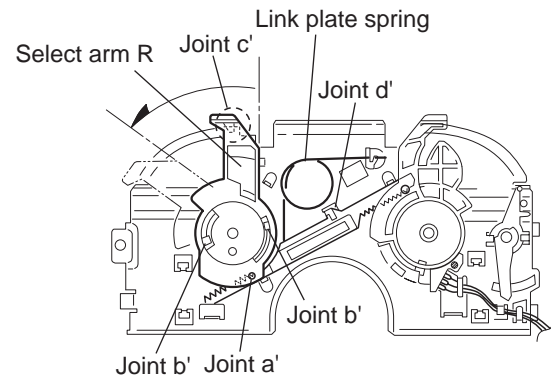

Fig.29

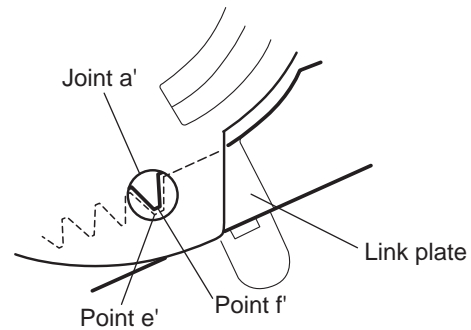

Fig.30

**3.2.15 Removing the loading roller assembly**  
(See Figs.31 to 33)

- Prior to performing the following procedure, remove the clamber assembly and top plate assembly.
- (1) Push inward the loading roller assembly on the gear side and detach it upward from the slot of the joint **g'** of the lock arm rivet assembly.
- (2) Detach the loading roller assembly from the slot of the joint **h'** of the lock arm rivet assembly.

The roller guide comes off the gear section of the loading roller assembly.

Remove the roller guide and the HL washer from the shaft of the loading roller assembly.

- (3) Remove the screw **J** attaching the lock arm rivet assembly.
- (4) Push the shaft at the joint **i'** of the lock arm rivet assembly inward to release the lock arm rivet assembly from the slot of the L side plate.
- (5) Extend the lock arm rivet assembly outward and release the joint **j'** from the boss of the chassis rivet assembly. The roller guide springs on both sides come off at the same time.

**CAUTION:**

When reassembling, reattach the left and right roller guide springs to the lock arm rivet assembly before reattaching the lock arm rivet assembly to the chassis rivet assembly. Make sure to fit the part **k'** of the roller guide spring inside of the roller guide. (Refer to Fig.34.)

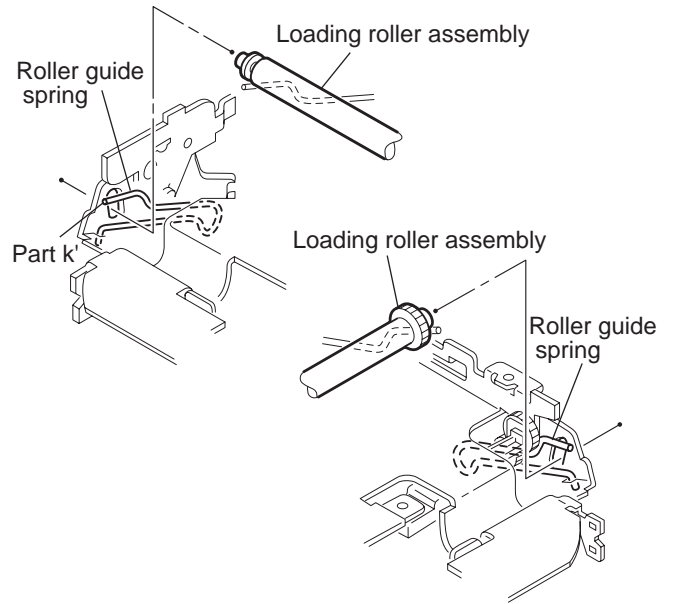

Fig.32

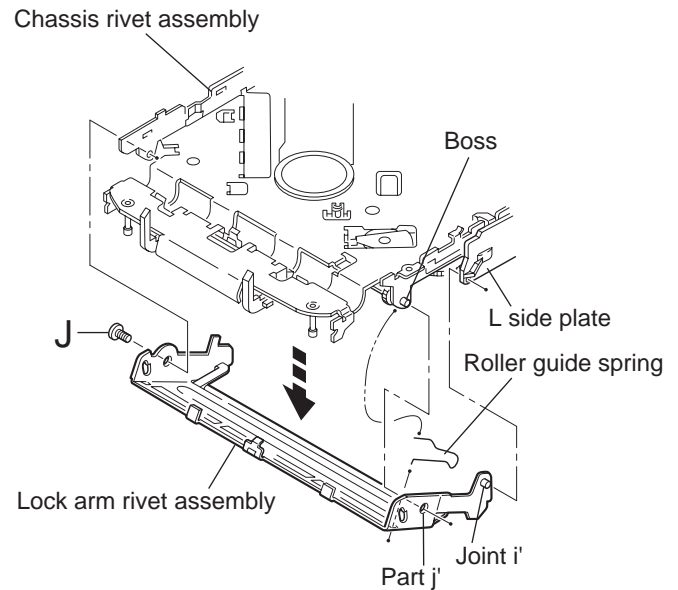

Fig.33

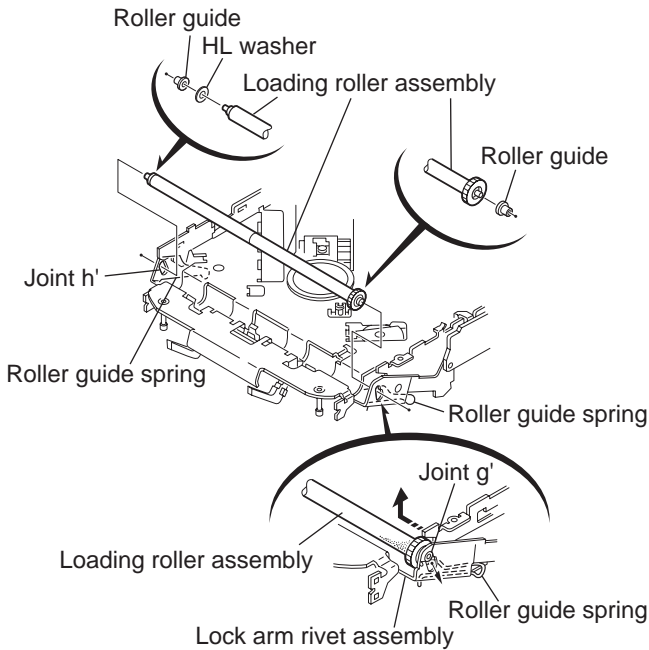

Fig.31

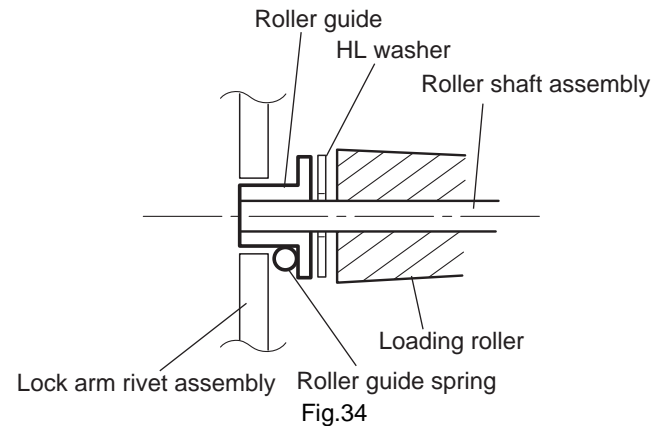
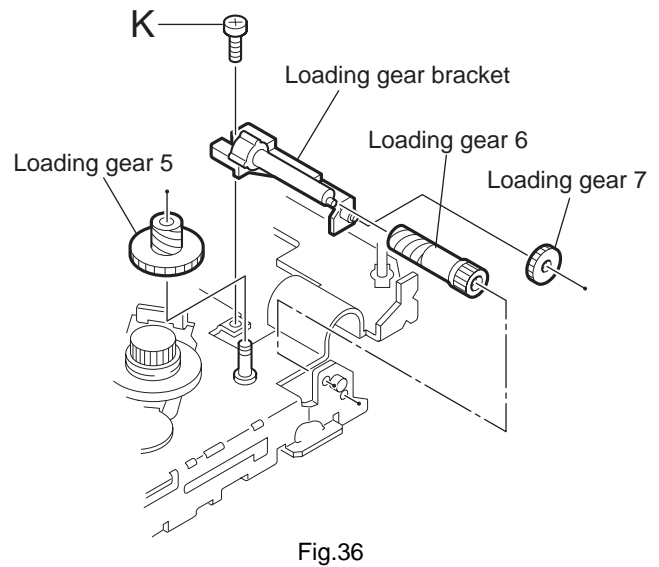
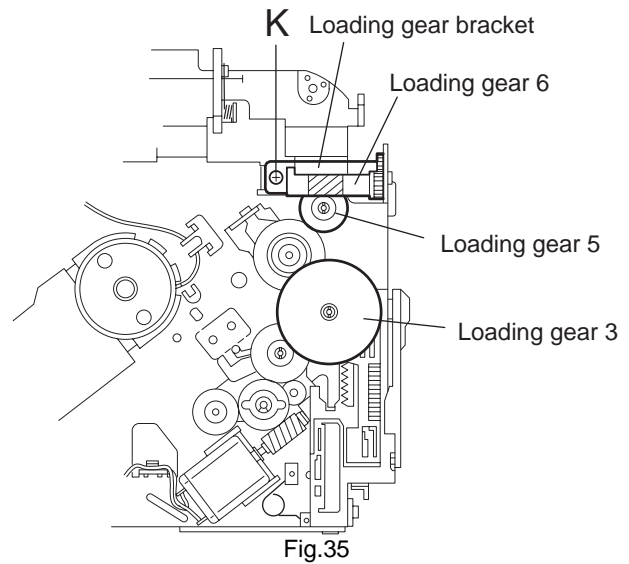

Fig.34

### 3.2.16 Removing the loading gear 5, 6 and 7 (See Figs.35 and 36)

- Prior to performing the following procedure, remove the top cover, chassis unit, pickup unit and top plate assembly.
  - (1) Remove the screw **K** attaching the loading gear bracket.  
The loading gear 6 and 7 come off the loading gear bracket.
  - (2) Pull out the loading gear 5.



### 3.2.17 Removing the gears (See Figs.37 to 40)

- Prior to performing the following procedure, remove the top cover, chassis unit, top plate assembly and pickup unit.
- Pull out the loading gear 3. (See Fig.35.)
  - (1) Pull out the feed gear.
  - (2) Move the loading plate assembly in the direction of the arrow to release the L side plate from the two slots m' of the chassis rivet assembly. (See Fig.37.)
  - (3) Detach the loading plate assembly upward from the chassis rivet assembly while releasing the joint n'. Remove the slide hook and loading plate spring from the loading plate assembly.
  - (4) Pull out the loading gear 2 and remove the change lock lever.
  - (5) Remove the E ring and washer attaching the changer gear 2.
  - (6) The changer gear 2, change gear spring and adjusting washer come off.
  - (7) Remove the loading gear 1.
  - (8) Move the change plate rivet assembly in the direction of the arrow to release from the three shafts of the chassis rivet assembly upward. (See Fig.38.)
  - (9) Detach the loading gear plate rivet assembly from the shaft of the chassis rivet assembly upward while releasing the joint p'. (See Figs.38 and 40.)
  - (10) Pull out the loading gear 4.

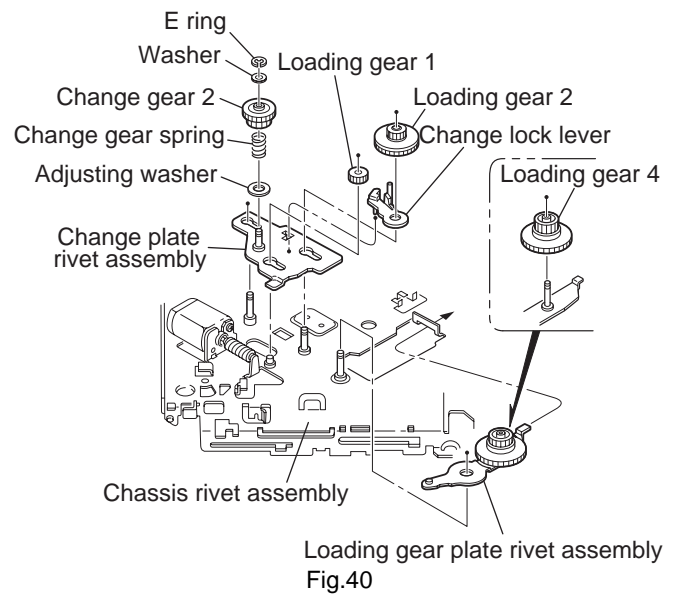
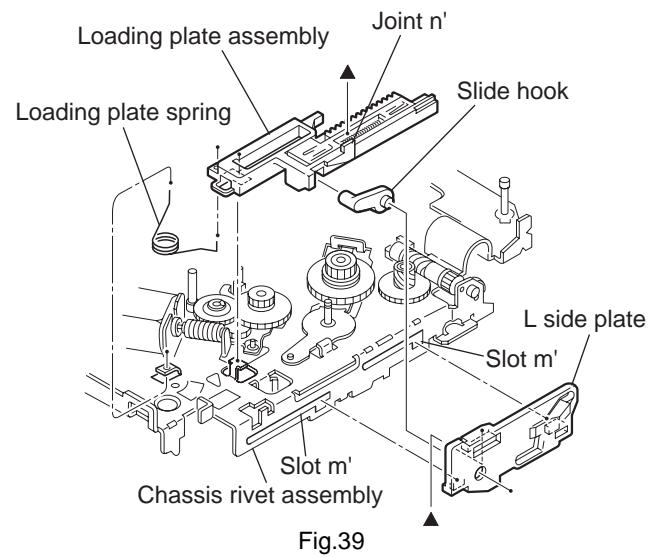
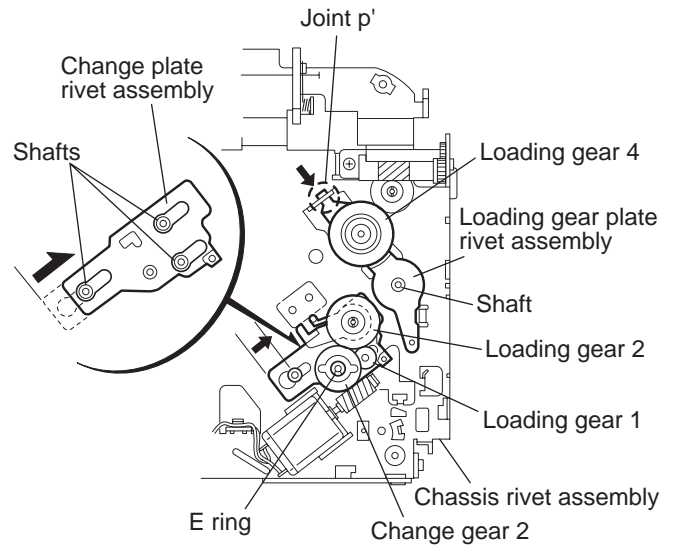
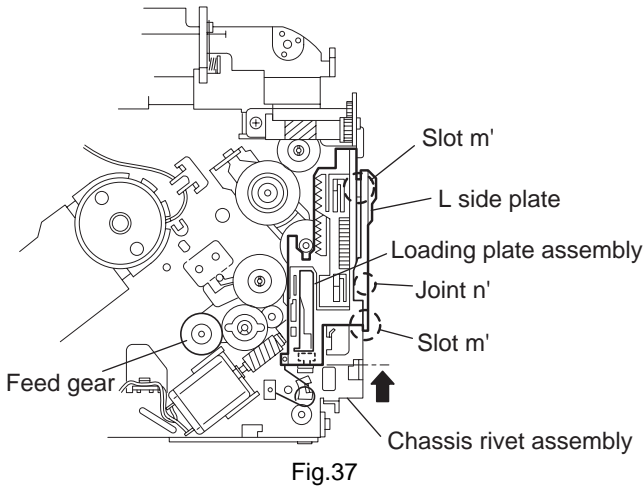

### 3.2.18 Removing the turn table / spindle motor (See Figs.41 and 42)

- Prior to performing the following procedure, remove the top cover, connector board, chassis unit and clamper assembly.
  - (1) Remove the two screws **L** attaching the spindle motor assembly through the slot of the turn table on top of the body.
  - (2) Unsolder the wire on the connector board if necessary.

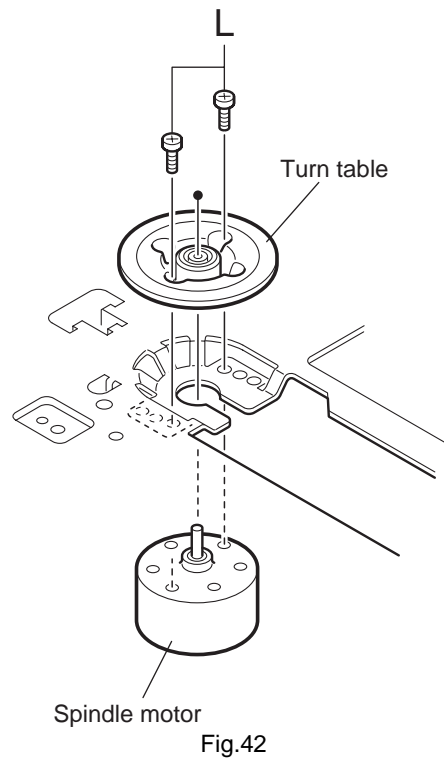
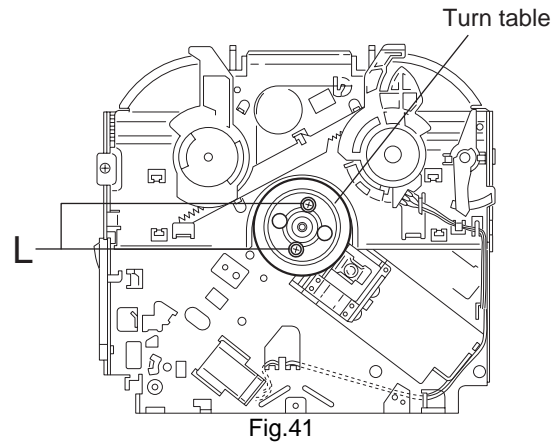



## SECTION 4 ADJUSTMENT

### 4.1 Adjustment method

#### ■ Test instruments required for adjustment

- (1) Digital oscilloscope (100MHz)
- (2) AM Standard signal generator
- (3) FM Standard signal generator
- (4) Stereo modulator
- (5) Electric voltmeter
- (6) Digital tester
- (7) Tracking offset meter
- (8) Test Disc JVC :CTS-1000
- (9) Extension cable for check  
EXTSH002-22P × 1

#### ■ Standard volume position

Balance and Bass & Treble volume : Indication "0"  
Loudness : OFF

#### ■ How to connect the extension cable for adjusting

##### Caution:

Be sure to attach the heat sink and rear bracket onto the power amplifier IC and regulator IC respectively, before supply the power. If voltage is applied without attaching these parts, the power amplifier IC and regulator IC will be destroyed by heat.

#### ■ Standard measuring conditions

Power supply voltage	DC14.4V(10.5 to 16V)
Load impedance	20K $\Omega$ (2 Speakers connection)
Output Level	Line out 2.0V (Vol. MAX)

#### ■ Dummy load

Exclusive dummy load should be used for AM, and FM. For FM dummy load, there is a loss of 6dB between SSG output and antenna input. The loss of 6dB need not be considered since direct reading of figures are applied in this working standard.

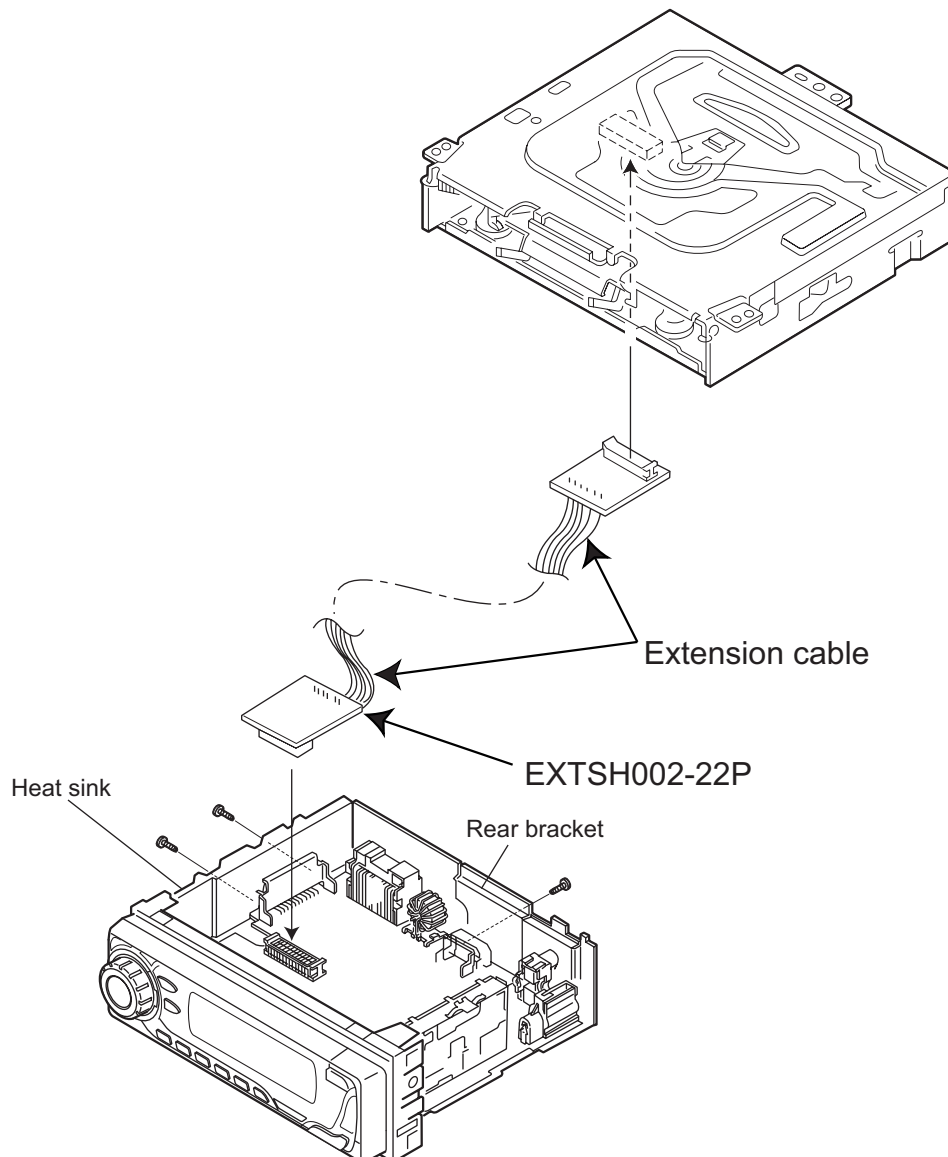

# SECTION 5 TROUBLE SHOOTING

## 5.1 Feed section

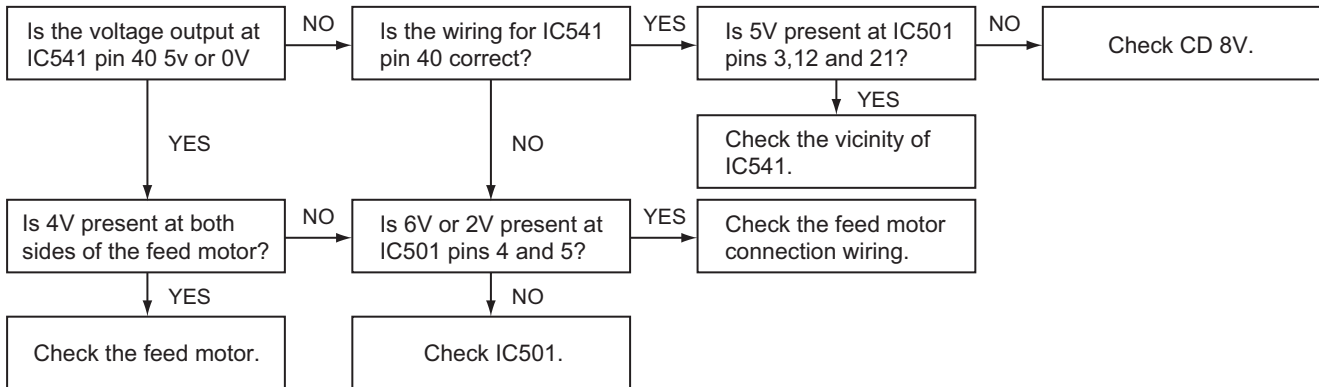

## 5.2 Focus section

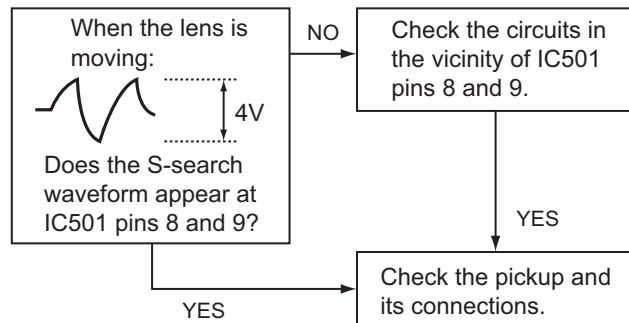

## 5.3 Spindle section

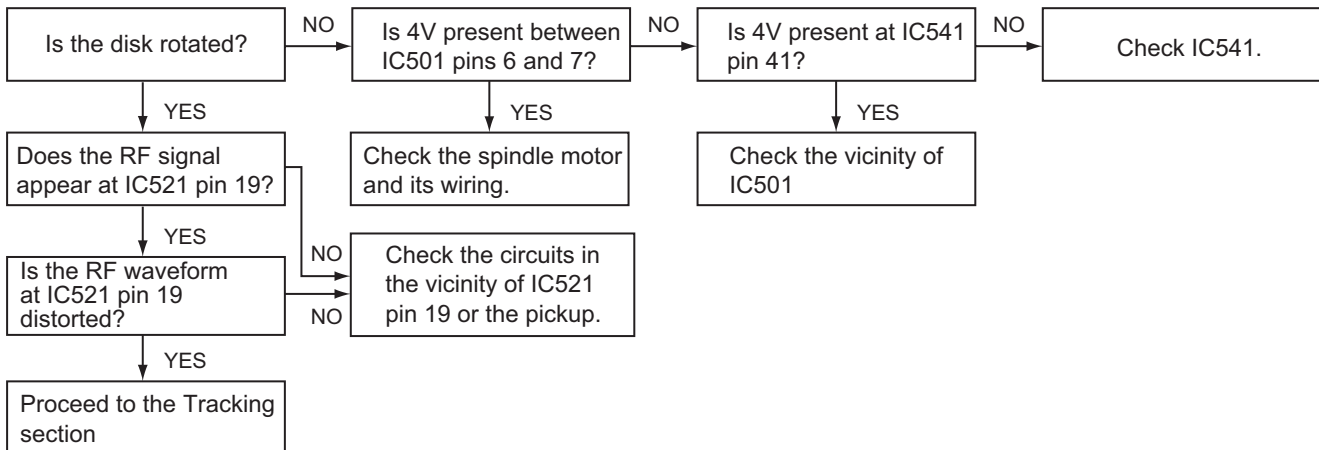

## 5.4 Tracking section

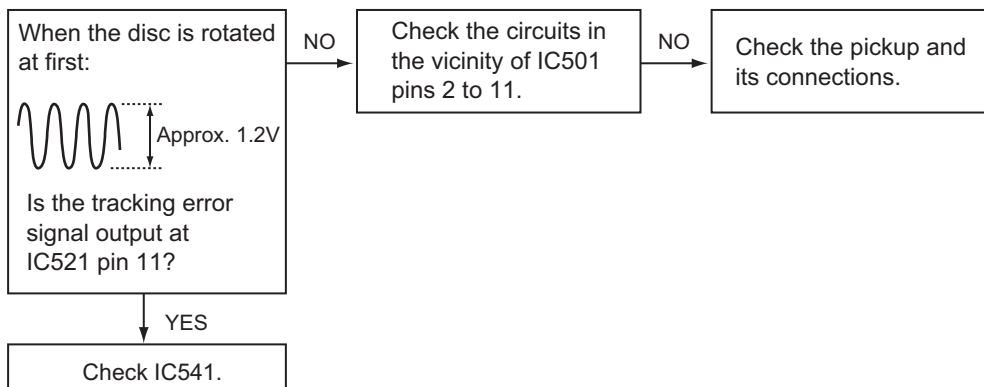

## 5.5 Signal processing section

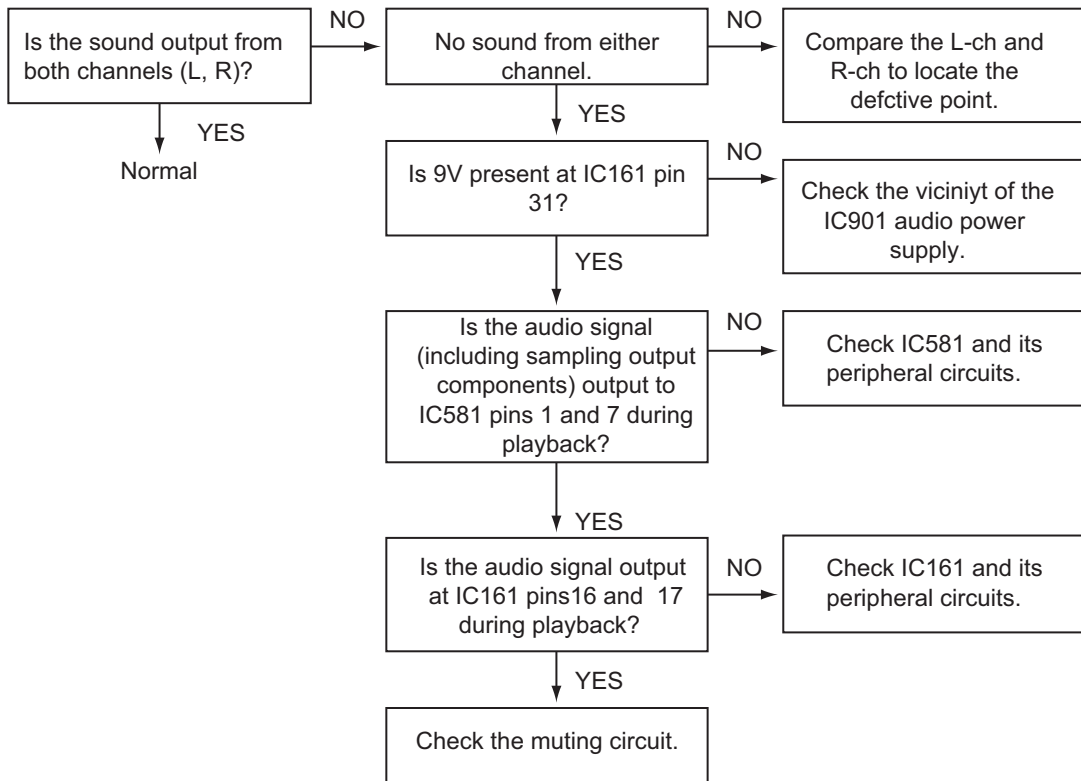

## 5.6 Maintenance of laser pickup

### (1) Cleaning the pick up lens

Before you replace the pick up, please try to clean the lens with a alcohol soaked cotton swab.

### (2) Life of the laser diode

When the life of the laser diode has expired, the following symptoms will appear.

- The level of RF output (EFM output: amplitude of eye pattern) will be low.

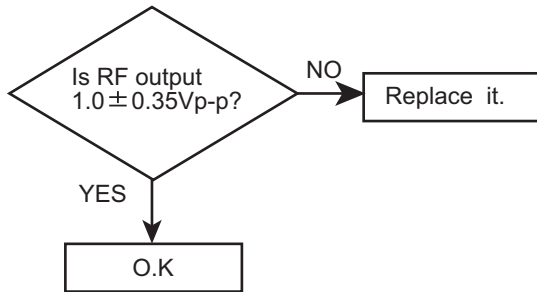

### (3) Semi-fixed resistor on the APC PC board

The semi-fixed resistor on the APC printed circuit board which is attached to the pickup is used to adjust the laser power. Since this adjustment should be performed to match the characteristics of the whole optical block, do not touch the semi-fixed resistor.

If the laser power is lower than the specified value, the laser diode is almost worn out, and the laser pickup should be replaced. If the semi-fixed resistor is adjusted while the pickup is functioning normally, the laser pickup may be damaged due to excessive current.

## 5.7 Replacement of laser pickup

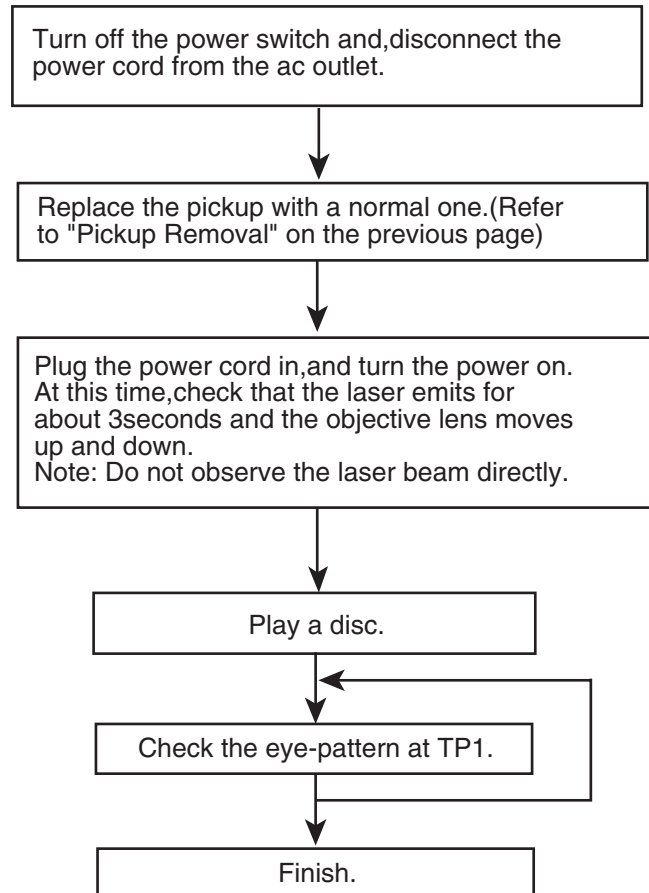

5.8 16 pin cord diagram

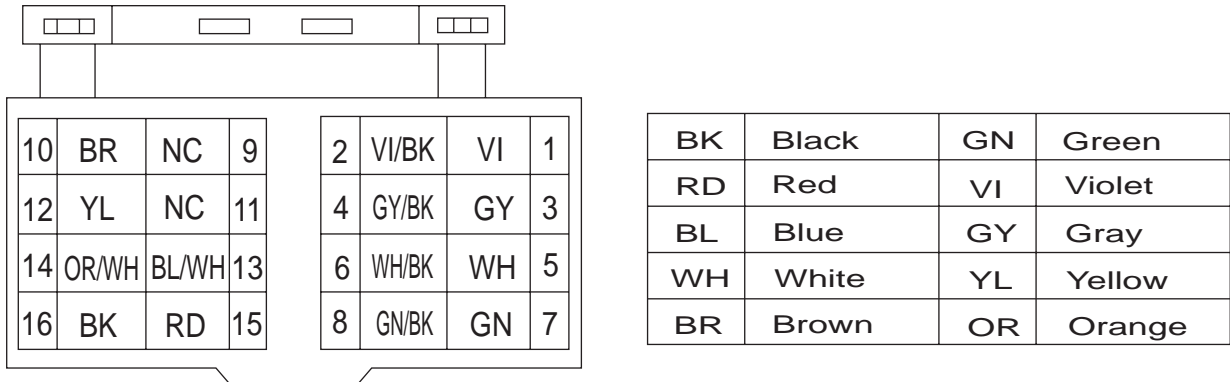

RR	Rear Right	ANT	Auto Antenna
FR	Front Right	ACC	ACC Line
FL	Front Left	TEL	Telephone Muting
RL	Rear Left	GND	Ground
REMOTE	Remote	MEMORY	Memory Backup Battery+
ILL	Illuminations Control		



**JVC**

VICTOR COMPANY OF JAPAN, LIMITED

AV & MULTIMEDIA COMPANY MOBILE ENTERTAINMENT CATEGORY 10-1,1chome,Ohwatari-machi,Maebashi-city,371-8543,Japan

(No.MA038)



Printed in Japan  
WPC

# JVC

# SCHEMATIC DIAGRAMS

## CD RECEIVER

# KD-G501, KD-G507

CD-ROM No.SML200401

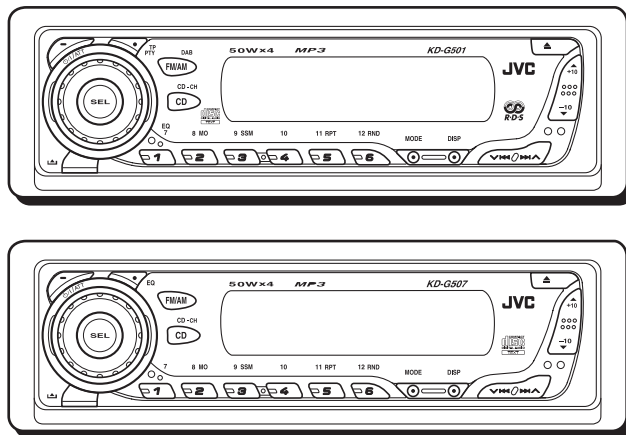
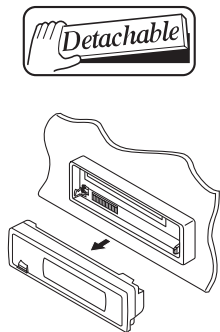

<b>KD-G501</b>
Area suffix
E ----- Continental Europe

<b>KD-G507</b>
Area suffix
EE ----- Russian Federation
EX ----- Central Europe



	KD-G501E	KD-G507EX/EE
STEERING CABLE	○	×

### Contents

Block diagram .....	2-1
Standard schematic diagrams .....	2-2 to 7
Printed circuit boards .....	2-8, 9

## Safety precaution

 **CAUTION** Burrs formed during molding may be left over on some parts of the chassis. Therefore, pay attention to such burrs in the case of performing repair of this system.

 **CAUTION** Please use enough caution not to see the beam directly or touch it in case of an adjustment or operation check.



# Block diagram

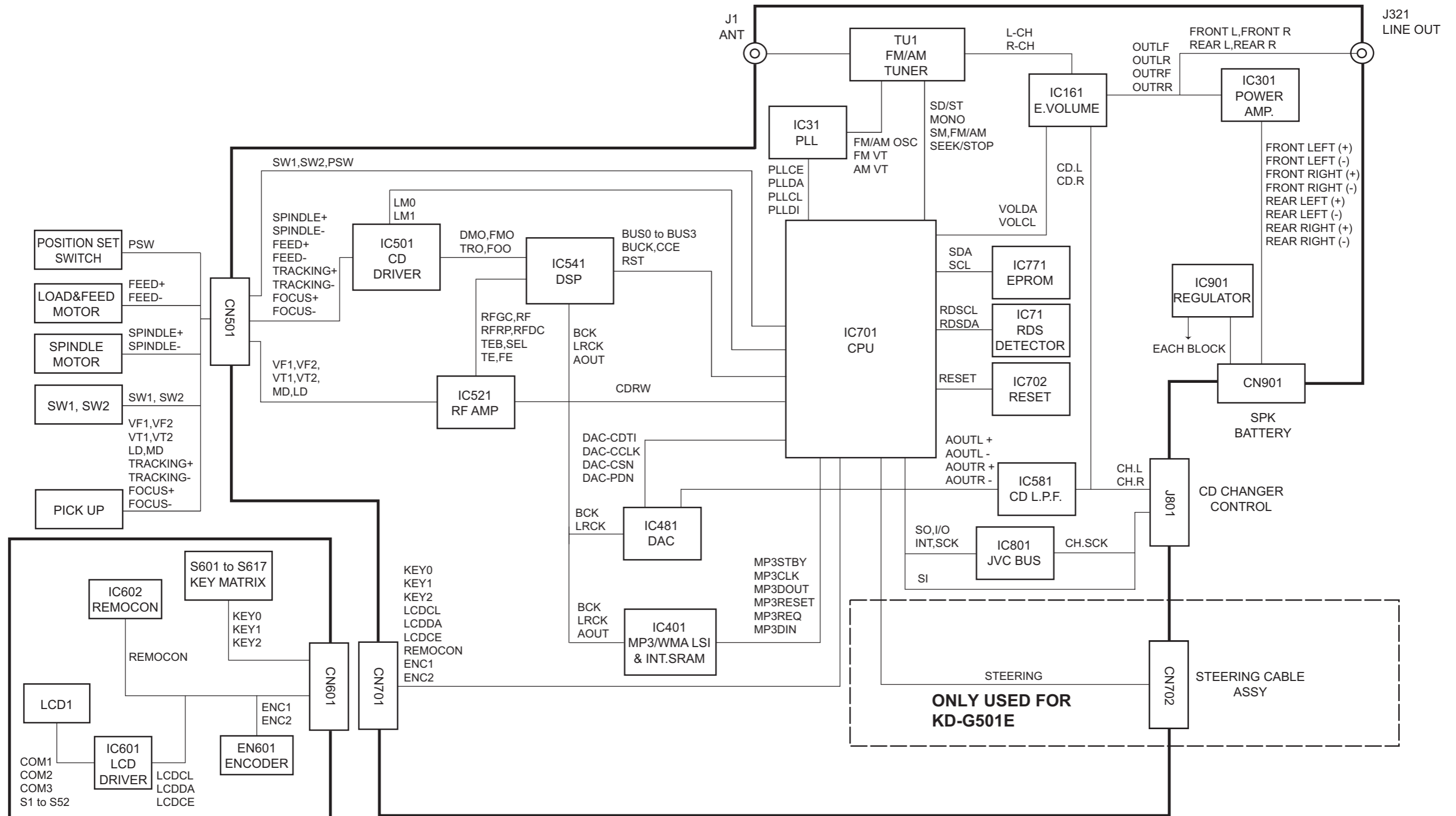

# Standard schematic diagrams

## ■ Main amplifier section (KD-G501)

- NOTES
1. VOLTAGES ARE DC-MEASURED WITH A DIGITAL VOLT METER WITHOUT INPUT SIGNAL CONDITION—FM MODE. □ AM MODE. ( ) IC0 MODE.
  2. UNLESS OTHERWISE SPECIFIED, ALL RESISTORS ARE 1/16W 5% METAL GLAZE RESISTOR. ALL CAPACITORS ARE 50V OR 25V CERAMIC CAPACITOR. ALL RESISTANCE VALUES ARE IN OHM. ALL CAPACITANCE VALUES ARE IN pF. ALL E-CAPACITORS ARE SHOWN IN THE FORM OF CAPACITANCE(μF)/RATED VOLTAGE(V).
  3. COMPONENTS IN ( ) INDICATE NOT USE.

(SHEET 2)

To CN601  
(SHEET 3)

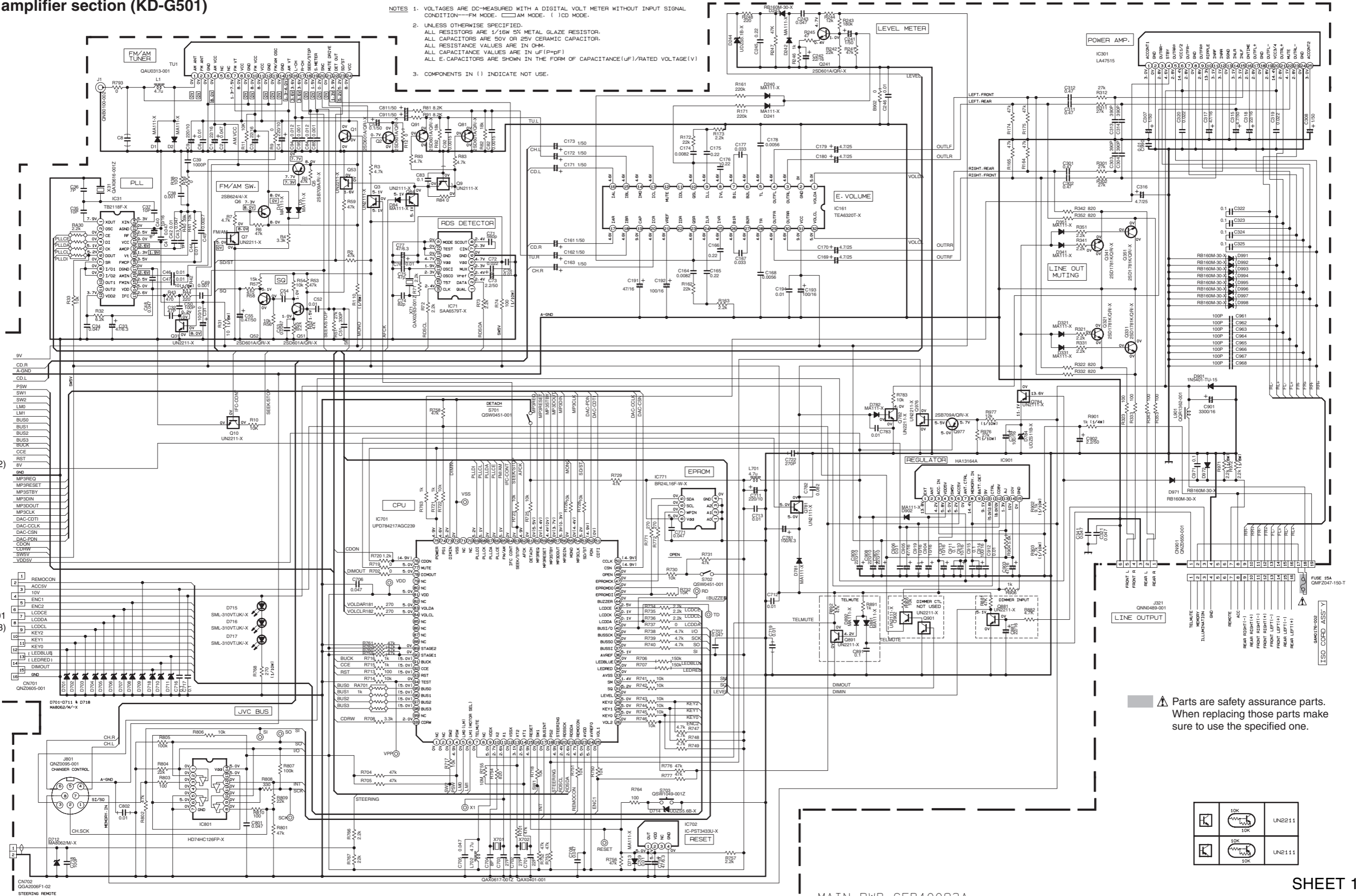

▲ Parts are safety assurance parts. When replacing those parts make sure to use the specified one.

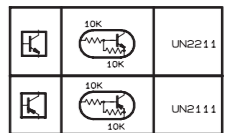

SHEET 1

MAIN PWB GEB10093A

■ CD servo section (KD-G501)

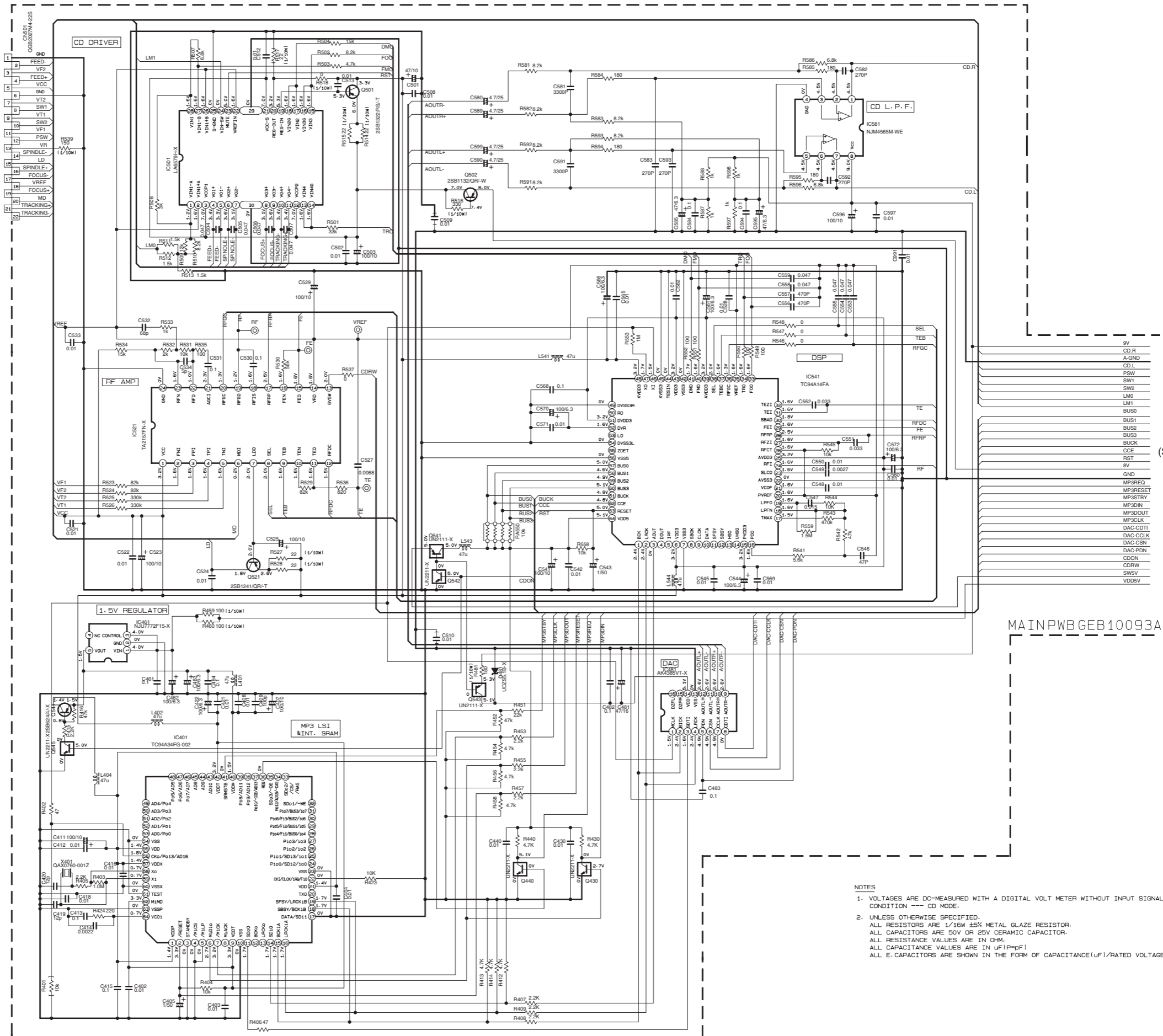
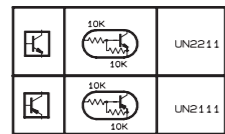
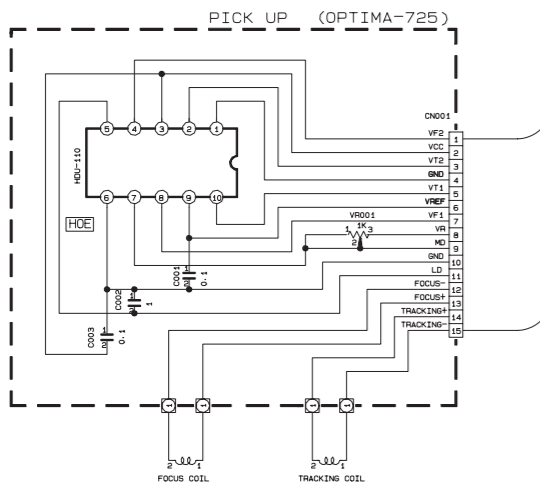
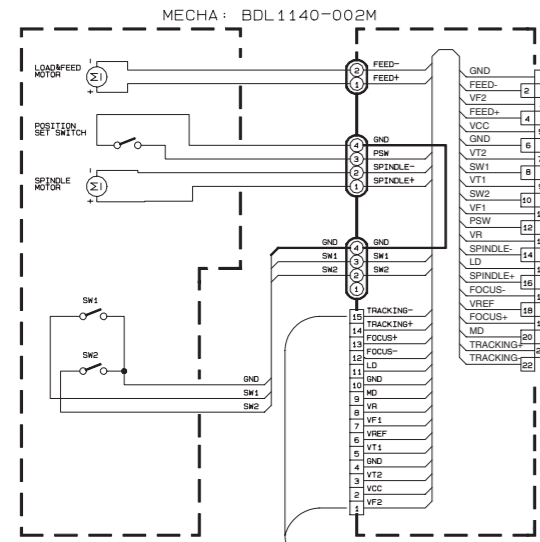

(SHEET 1)

MAINPWB GEB10093A

- NOTES
- VOLTAGES ARE DC-MEASURED WITH A DIGITAL VOLT METER WITHOUT INPUT SIGNAL CONDITION --- CD MODE.
  - UNLESS OTHERWISE SPECIFIED:  
ALL RESISTORS ARE 1/16W ±5% METAL GLAZE RESISTOR.  
ALL CAPACITORS ARE 50V OR 25V CERAMIC CAPACITOR.  
ALL RESISTANCE VALUES ARE IN OHM.  
ALL CAPACITANCE VALUES ARE IN uF (P=PF)  
ALL E-CAPACITORS ARE SHOWN IN THE FORM OF CAPACITANCE(uF)/RATED VOLTAGE(V)

■ LCD & Key control section (KD-G501)

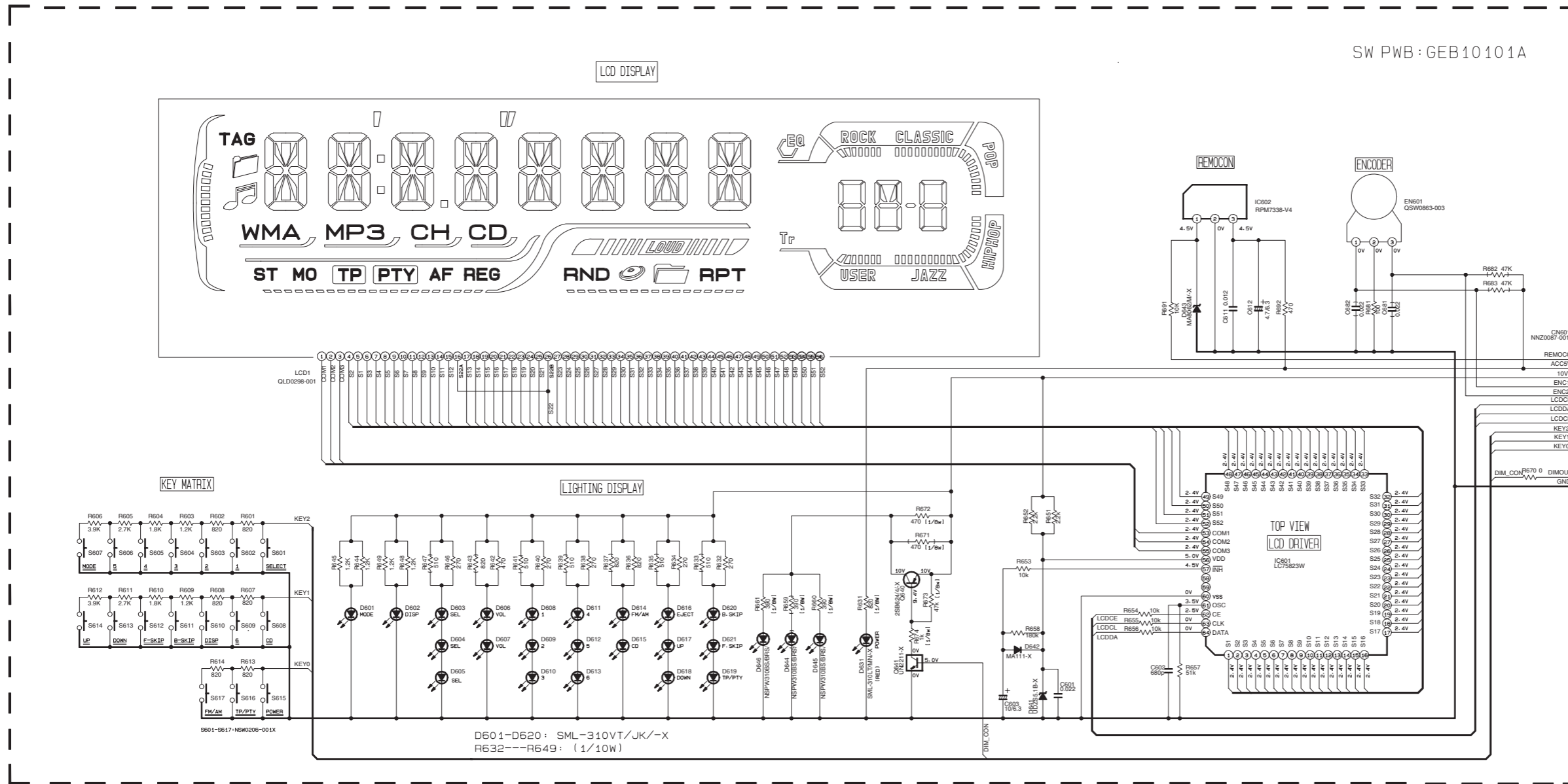

SW PWB : GEB10101A

To CN701 (SHEET 1)

NOTES

1. VOLTAGES ARE DC-MEASURED WITH A DIGITAL VOLT METER WITHOUT INPUT SIGNAL.
2. UNLESS OTHERWISE SPECIFIED:  
ALL RESISTORS ARE 1/16W METAL GLAZE RESISTORS.  
ALL CAPACITORS ARE 50V OR 25V CERAMIC CAPACITOR.  
ALL RESISTANCE VALUES ARE IN OHM.  
ALL CAPACITANCE VALUES ARE IN uF(P=pF)  
ALL E. CAPACITORS ARE SHOWN IN THE FORM OF CAPACITANCE(uF)/RATED VOLTAGE(V).  
T --- TANTALUM CAPACITOR.
3. COMPONENTS IN ( ) INDICATE NOT USE.

	10K	UN2211
	10K	UN2111



■ Main amplifier section (KD-G507)

- NOTES 1. VOLTAGES ARE DC-MEASURED WITH A DIGITAL VOLT METER WITHOUT INPUT SIGNAL CONDITION—FM MODE. □ ICD MODE.
2. UNLESS OTHERWISE SPECIFIED, ALL RESISTORS ARE 1/4W 5% METAL GLAZE RESISTOR. ALL CAPACITORS ARE 50V OR 25V CERAMIC CAPACITOR. ALL RESISTANCE VALUES ARE IN OHM. ALL CAPACITANCE VALUES ARE IN uF (P=pF) ALL E. CAPACITORS ARE SHOWN IN THE FORM OF CAPACITANCE(uF)/RATED VOLTAGE(V)
3. COMPONENTS IN ( ) INDICATE NOT USE.

(SHEET 5)

To CN601 (SHEET 6)

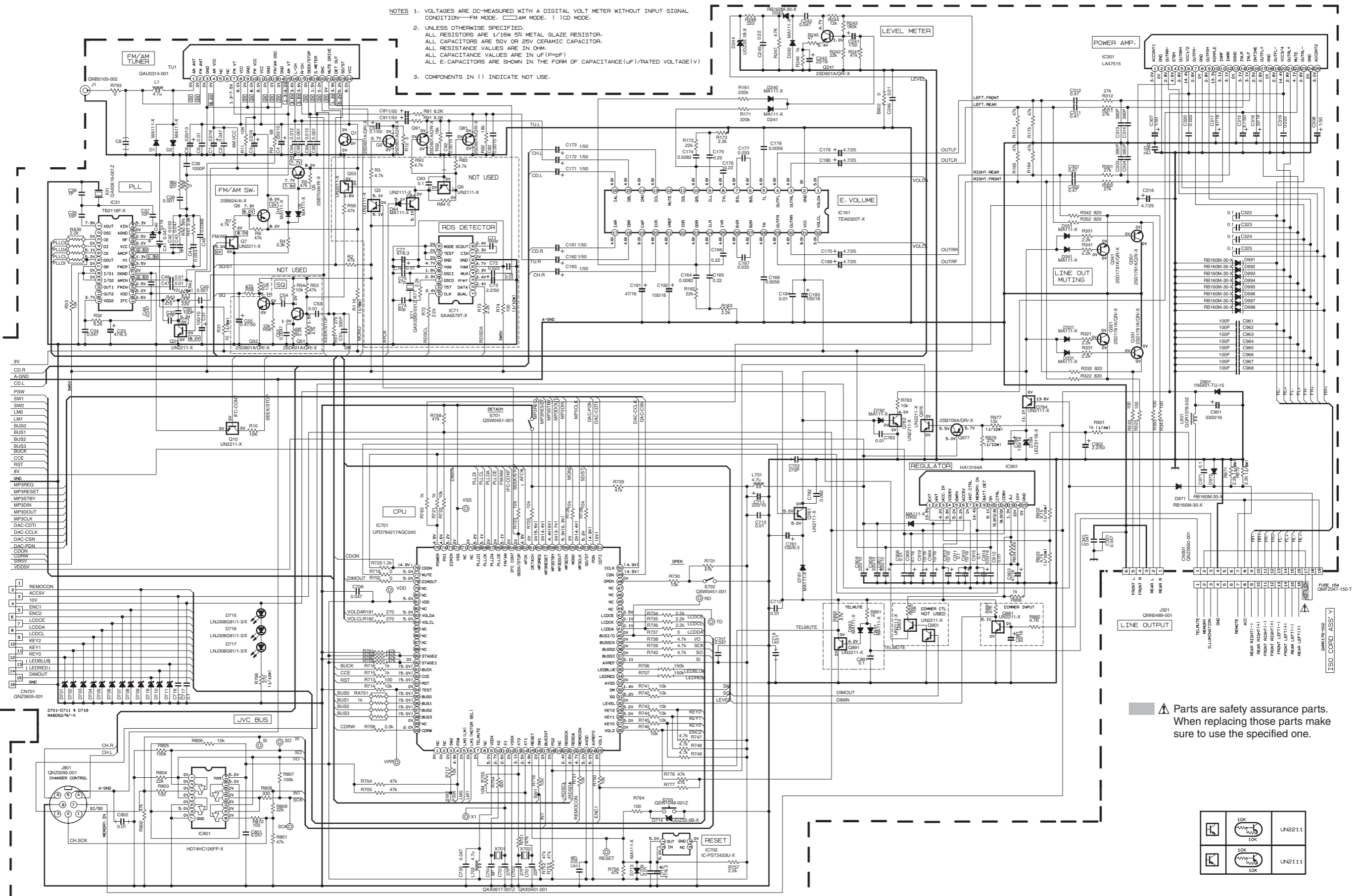

⚠ Parts are safety assurance parts. When replacing those parts make sure to use the specified one.

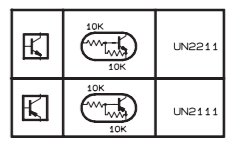

■ CD servo section (KD-G507)

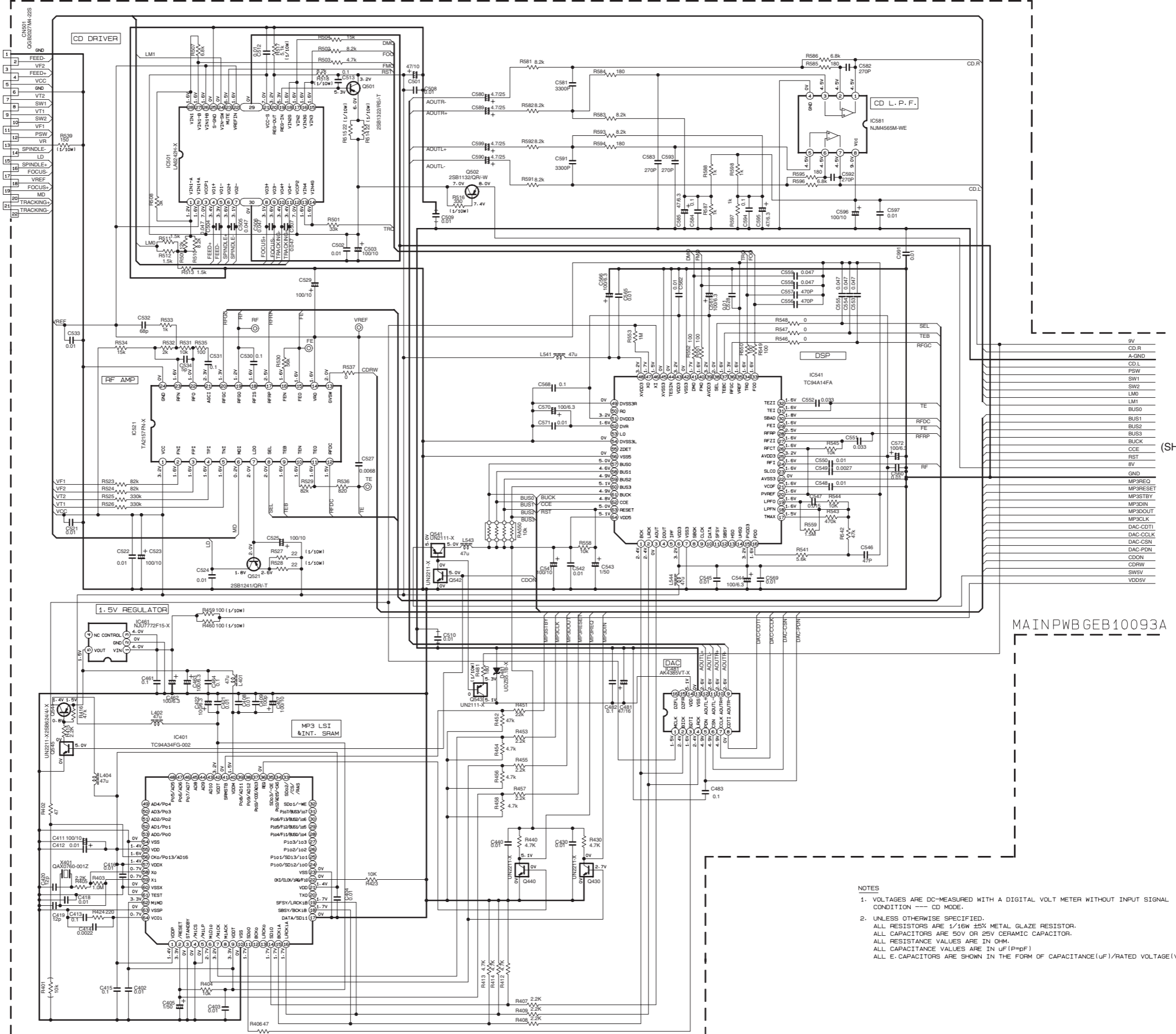
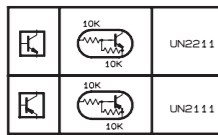
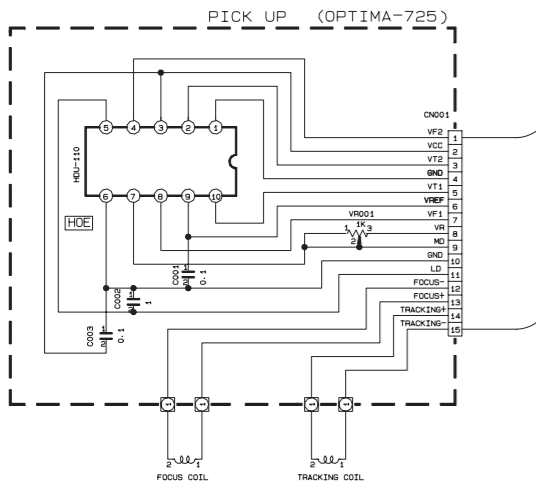
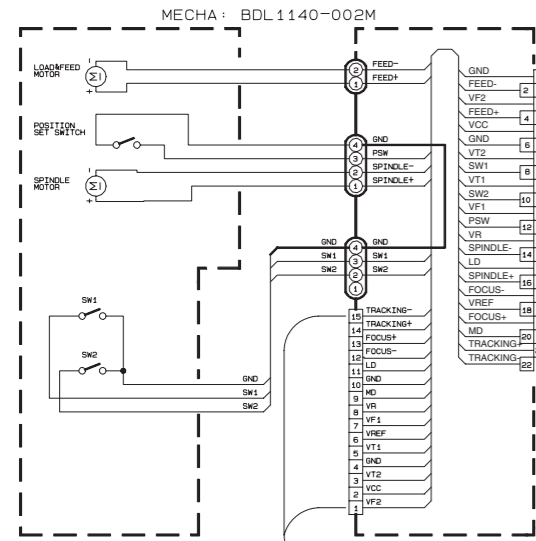

(SHEET 4)

MAIN PWB GEB10093A

- NOTES
- VOLTAGES ARE DC-MEASURED WITH A DIGITAL VOLT METER WITHOUT INPUT SIGNAL CONDITION --- CD MODE.
  - UNLESS OTHERWISE SPECIFIED, ALL RESISTORS ARE 1/16W ±5% METAL GLAZE RESISTOR. ALL CAPACITORS ARE 50V OR 25V CERAMIC CAPACITOR. ALL RESISTANCE VALUES ARE IN OHM. ALL CAPACITANCE VALUES ARE IN uF(P=pF) ALL E. CAPACITORS ARE SHOWN IN THE FORM OF CAPACITANCE(uF)/RATED VOLTAGE(V)

■ LCD & Key control section (KD-G507)

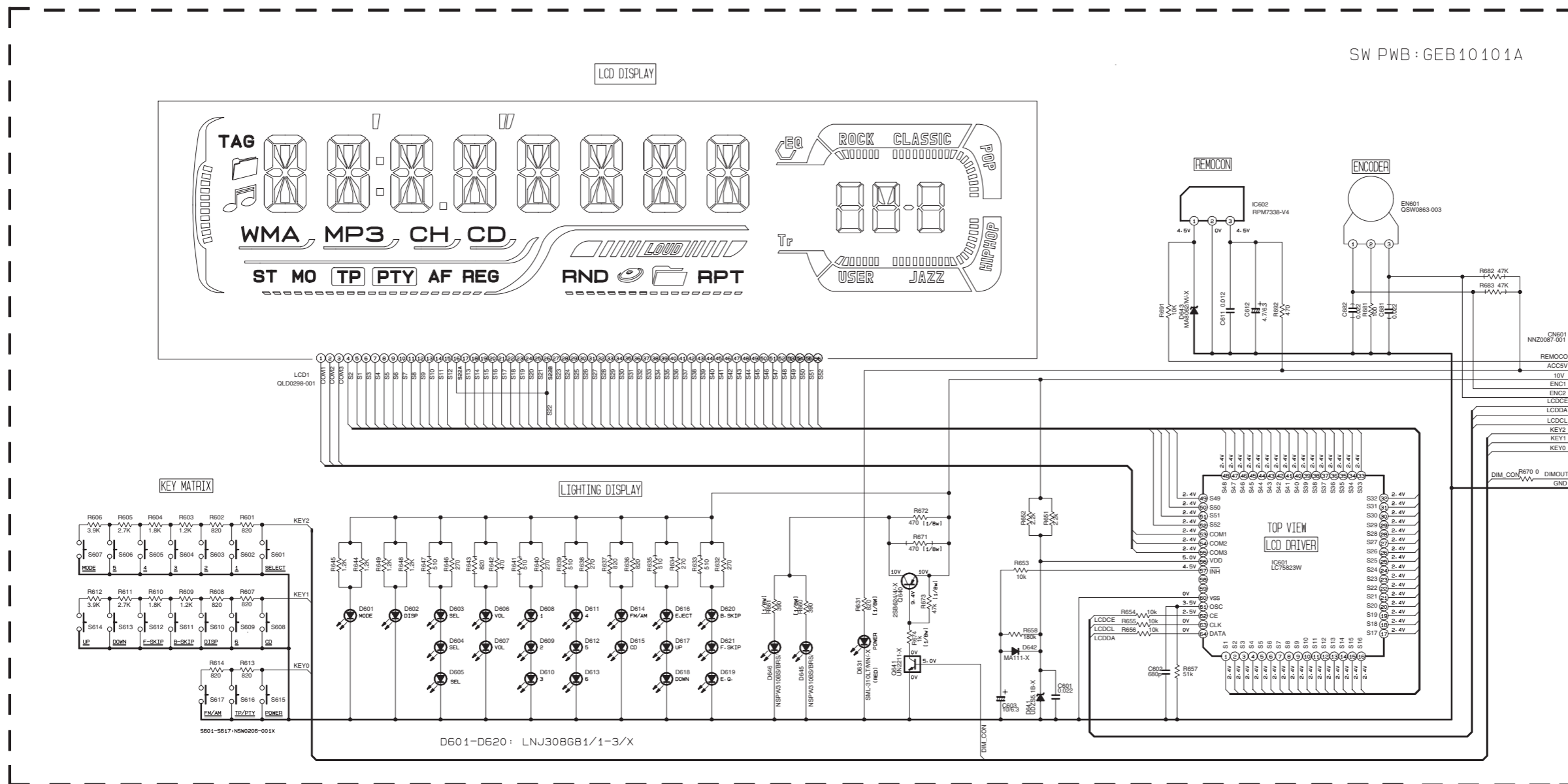

To CN701  
(SHEET 4)

	10K	UN2211
	10K	UN2111

- NOTES
- VOLTAGES ARE DC-MEASURED WITH A DIGITAL VOLT METER WITHOUT INPUT SIGNAL.
  - UNLESS OTHERWISE SPECIFIED, ALL RESISTORS ARE 1/16W METAL GLAZE RESISTORS. ALL CAPACITORS ARE 50V OR 25V CERAMIC CAPACITOR. ALL RESISTANCE VALUES ARE IN OHM. ALL CAPACITANCE VALUES ARE IN uF(P=pF). ALL E-CAPACITORS ARE SHOWN IN THE FORM OF CAPACITANCE(uF)/RATED VOLTAGE(V). T — TANTALUM CAPACITOR.
  - COMPONENTS IN ( ) INDICATE NOT USE.









**JVC**

**VICTOR COMPANY OF JAPAN, LIMITED**

AV & MULTIMEDIA COMPANY MOBILE ENTERTAINMENT CATEGORY 10-1,1chome,Ohwatari-machi,Maebashi-city,371-8543,Japan

(No.MA038SCH)



Printed in Japan  
WPC

# PARTS LIST

[ KD-G501 ]

[ KD-G507 ]

\* All printed circuit boards and its assemblies are not available as service parts.

<b>KD-G501</b>	
Area suffix	
E	Continental Europe
EX	Central Europe

<b>KD-G507</b>	
Area suffix	
EE	Russian Federation

- Contents -

Exploded view of general assembly and parts list (Block No.M1)	3- 2
CD mechanism assembly and parts list (Block No.MB)	3- 4
Electrical parts list (Block No.01~02)	3- 6
Packing materials and accessories parts list (Block No.M3)	3-14

# Exploded view of general assembly and parts list

Block No. 

M	1	M	M
---	---	---	---

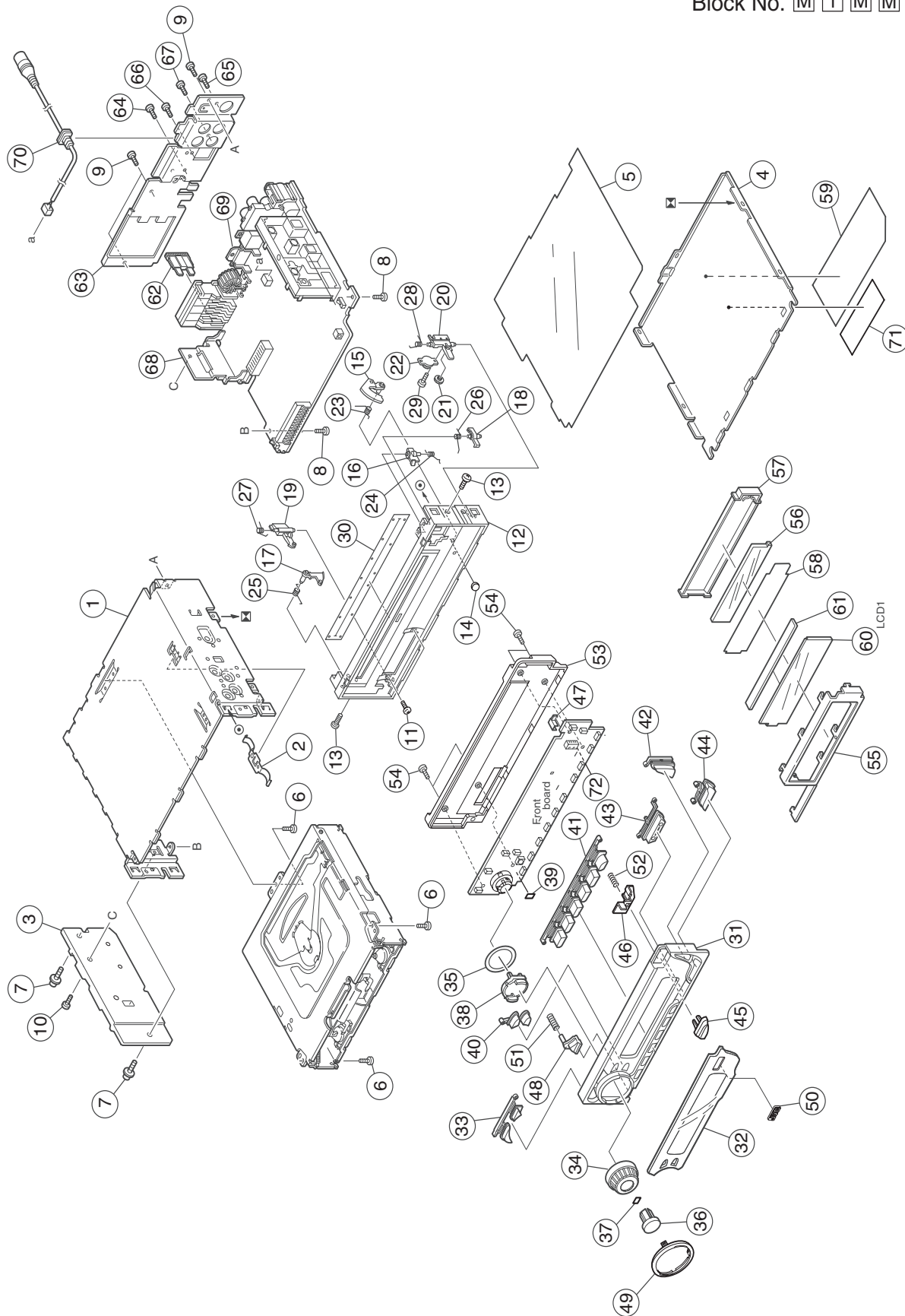

# General Assembly

Block No. [M][1][M][M]

△ Symbol No.	Part No.	Part Name	Description	Local
1	GE10043-210A	TOP CHASSIS		
2	GE40135-001A	EARTH PLATE		
3	GE30938-003A	SIDE PANEL		
4	GE30393-002A	BOTTOM COVER		
5	FSMA3005-001	INSULATOR		
6	QYSDST2604Z	SCREW	2.6mm x 4mm(x3)	
7	FSKZ4005-001	SCREW	(x2)	
8	QYSDST2606Z	SCREW	2.6mm x 6mm(x2)	
9	QYSDST2604Z	SCREW	2.6mm x 4mm(x3)	
10	QYSDST2610Z	SCREW	2.6mm x 10mm	
11	QYSDSF2006M	SCREW	2mm x 6mm(x2)	
12	GE30823-001A	F. CHASSIS ASSY		
13	QYSDST2004M	MINI SCREW	2mm x 4mm(x2)	
14	FSYH4036-098	SHEET		
15	GE30827-002A	OPEN LEVER		
16	GE30824-002A	LOCK LEVER(O.L)		
17	GE31245-001A	RELEASE LEVER		
18	GE30829-001A	LOCK LEVER(TOP)		
19	GE30825-002A	LOCK LEVER(L)		
20	GE30828-002A	LOCK LEVER(R)		
21	GE40154-001A	GEAR		
22	QZW0108-002	OIL DAMPER		
23	GE40153-001A	T.SPRING		
24	GE40157-001A	T.SPRING		
25	VKW5264-005	T.SPRING		
26	FSKW4012-002	T.SPRING		
27	VKW5263-002	T.SPRING		
28	GE40155-001A	T.SPRING		
29	QYSDSF2006M	SCREW	2mm x 6mm	
30	GE40156-001A	BLIND		
31	GE10080-004A	FRONT PANEL		
32	GE31048-009A	FINDER ASSY		G501 E,G50 1EX
32	GE31048-012A	FINDER ASSY		G507 EE
33	GE31044-001A	POWER BUTTON		
34	GE31038-001A	VOLUME KNOB		
35	GE40218-002A	SHEET		
36	GE31039-003A	SEL BUTTON		
37	FSYH4036-053	SHEET		
38	GE31040-001A	RIM LENS		
39	FSYH4036-069	SHEET		
40	GE31029-001A	D.FUNC BTN		
41	GE20161-001A	PRESET BUTTON		
42	GE31043-001A	UP/DOWN BTN		
43	GE31028-003A	SSM BTN		
44	GE31025-001A	SEARCH BTN		
45	GE31041-004A	EJECT BUTTON		
46	GE31250-001A	EJECT COVER		
47	GE40220-001A	LIGHT SHIELD		
48	GE31042-004A	DETACH BTN		
49	GE31045-001A	RIM COVER		
50	GE40204-001A	JVC BADGE		
51	VKW3001-330	COMP.SPRING		
52	GE40202-004A	COMP.SPRING		
53	GE10081-001A	REAR COVER		
54	VKZ4777-001	MINI SCREW	(x4)	
55	GE31035-001A	LCD CASE		
56	GE31036-001A	LCD LENS		
57	GE31037-001A	LENS CASE		
58	GE40200-003A	LIGHTING SHEET		
59	GE31133-001A	NAME PLATE		G501 E,G50 1EX
59	GE31286-001A	NAME PLATE		G507 EE
60	QLD0298-001	LCD MODULE		
61	QNZ0442-001	LCD CONNECTOR		
△ 62	QMFZ047-150-T	FUSE	15A	
63	GE30912-005A	REAR BRACKET		
64	QYSDST2606Z	SCREW	2.6mm x 6mm	
65	QYSDST2606Z	SCREW	2.6mm x 6mm	
66	QYSDST2606Z	SCREW	2.6mm x 6mm	
67	QYSDSF2606Z	SCREW	2.6mm x 6mm	

△ Symbol No.	Part No.	Part Name	Description	Local
68	GE40172-004A	IC BRACKET		
69	GE40124-002A	REG BRACKET		
70	QAM0544-002	STEERING CABLE		G501 E,G50 1EX
71	LV41843-002A	LASER CAUTION		
72	GE30854-001A	LED HOLDER		

# CD mechanism assembly and parts list

Block No. **M B M M**

**Grease**

- ★ TNG-87
- ※ GP-501MK
- CFD-005Z
- ▲ GP-501A

TN-2001-1011

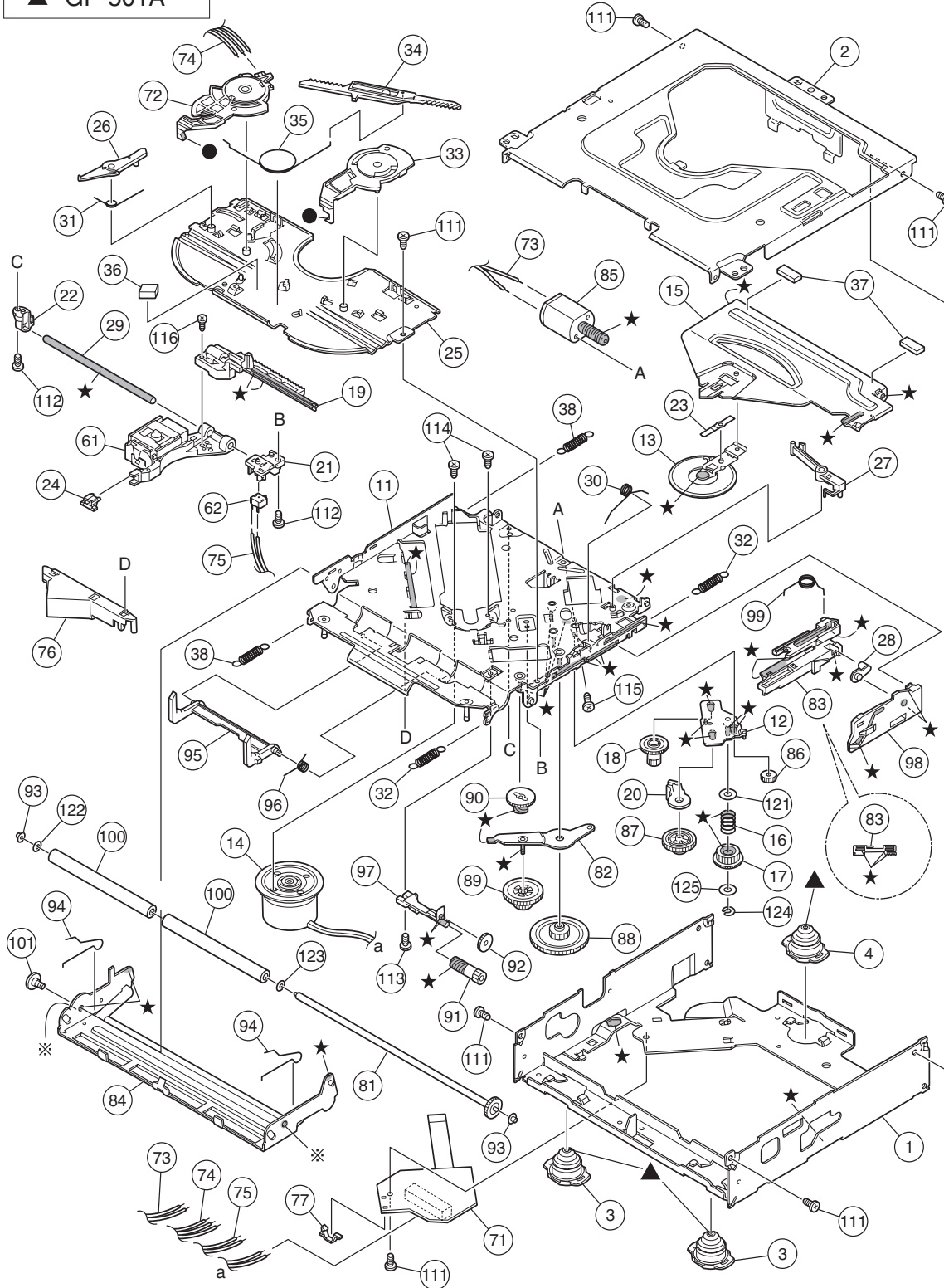

# CD mechanism

Block No. [M][B][M][M]

△ Symbol No.	Part No.	Part Name	Description	Local
1	30320101T	FRAME		
2	30320102T	TOP COVER		
3	30320115T	DANPER F		
4	30320116T	DANPER R		
11	303205505T	CHASSIS RIVET		
12	303205503T	CHANGE P. RVT A		
13	303205301T	CLAMPER ASS'Y		
14	303205302T	SPINDLE MOTOR A		
15	30320502T	CLAMPER ARM		
16	30320503T	CHANGE GEAR SPG		
17	30320505T	CHANGE GEAR 2		
18	30320506T	FEED GEAR		
19	30320507T	FEED RACK		
20	30320509T	CHANGE LOCK RAR		
21	30320510T	FEED SW HOLDER		
22	30320511T	PU SHAFT HOLDER		
23	30320513T	CLAMPER SUB SPG		
24	30320514T	FD SUB HOLDER		
25	30320518T	TOP PLATE		
26	30320519T	SELECT LOCK ARM		
27	30320520T	TRIGGER ARM		
28	30320521T	SLIDE HOOK		
29	30320522T	PU SHAFT		
30	30320525T	CLAMPER ARM SPG		
31	30320526T	SELECT L ARM SP		
32	30320538T	SUSPENSION SP R		
33	30320529T	SELECT ARM R		
34	30320530T	LINK PLATE		
35	30320531T	LINK PLATE SPG		
36	30320523T	CUSHION F		
37	30320524T	CUSHION R		
38	30320539T	SUSPENSION SP L		
61	69011614T	PICKUP OPT-725		
62	64180406T	DET SW ESE22		
71	303210301T	CONN PWB ASS'Y		
72	30321002T	MODE SW		
73	30321003T	LOAD MOTOR WIRE		
74	30321005T	MODE SW WIRE		
75	30321009T	SL WIRE		
76	30321011T	WIRE HOLDER		
77	19501403T	WIRE CLUMPER		
81	303211301T	ROLLER SHAFT AS		
82	303211501T	L GEAR PLATE RV		
83	303211302T	LOADING PLATE A		
84	303211502T	LOCK ARM RV ASS		
85	303211303T	L/F MOTOR ASS'Y		
86	30321101T	LOADING GEAR 1		
87	30321102T	LOADING GEAR 2		
88	30321103T	LOADING GEAR 3		
89	30321104T	LOADING GEAR 4		
90	30321105T	LOADING GEAR 5		
91	30321106T	LOADING GEAR 6		
92	30321107T	LOADING GEAR 7		
93	30321111T	ROLLER GUIDE		
94	30321114T	ROLLER GUIDE SP		
95	30321116T	DISC STOPPER AR		
96	30321117T	DISC ST ARM SPG		
97	30321118T	LD GEAR BRACKET		
98	30321125T	L SIDE PLATE		
99	30321131T	LOAD PLATE SPG		
100	30321133T	LDG ROLLER		
101	18211223T	COLLAR SCREW		
111	9P0420031T	SCREW		
112	9P0420041T	TAP.SCREW		
113	9B0320041T	SCREW		
114	9C0117183T	SCREW		
115	9C0120203T	SCREW		
116	9C0317503T	SCREW		
121	9W0130170T	PW 3.5X8X0.3		
122	9W0513060T	HL WASHER		
123	9W0710070T	L WASHER		
124	9E0100152T	E RING		
125	9W0113020T	PW 2.1X4X0.13		

# Electrical parts list

## Main board

Block No. [0][1][0][0]

△ Symbol No.	Part No.	Part Name	Description	Local
IC31	TB2118F-X	PLL IC		
IC71	SAA6579T-X	IC		G501 E,G50 1EX
IC161	TEA6320T-X	IC		
IC301	LA47515	IC		
IC401	TC94A34FG-002	IC		
IC461	NJU7772F15-X	IC		
IC481	AK4385VT-X	IC		
IC501	LA6579H-X	IC		G501 E,G50 1EX
IC501	LA6242H-X	IC		G507 EE
IC521	TA2157FN-X	RF AMP IC		
IC541	TC94A14FA	CD LSI IC		
IC581	NJM4565M-WE	IC		
IC701	UPD784217AGC239	IC		G501 E,G50 1EX
IC701	UPD784217AGC240	IC		G507 EE
IC702	IC-PST3433U-X	IC		
IC771	BR24L16F-W-X	IC		G501 E,G50 1EX
IC801	HD74HC126FP-X	IC		
IC901	HA13164A	IC		
Q1	2SD601A/QR/-X	TRANSISTOR		
Q2	2SD601A/QR/-X	TRANSISTOR		G501 E,G50 1EX
Q3	UN2111-X	TRANSISTOR		G501 E,G50 1EX
Q5	2SB709A/R/-X	TRANSISTOR		
Q6	2SB624/4/-X	TRANSISTOR		
Q7	UN2211-X	TRANSISTOR		
Q10	UN2211-X	TRANSISTOR		
Q31	UN2211-X	TRANSISTOR		
Q51	2SD601A/QR/-X	TRANSISTOR		G501 E,G50 1EX
Q52	2SD601A/QR/-X	TRANSISTOR		G501 E,G50 1EX
Q53	UN2211-X	TRANSISTOR		G501 E,G50 1EX
Q81	2SD601A/QR/-X	TRANSISTOR		G501 E,G50 1EX
Q84	UN2111-X	TRANSISTOR		G501 E,G50 1EX
Q91	2SD601A/QR/-X	TRANSISTOR		G501 E,G50 1EX
Q241	2SD601A/QR/-X	TRANSISTOR		
Q321	2SD1781K/QR/-X	TRANSISTOR		
Q331	2SD1781K/QR/-X	TRANSISTOR		
Q341	2SD1781K/QR/-X	TRANSISTOR		
Q351	2SD1781K/QR/-X	TRANSISTOR		
Q430	2SD601A/QR/-X	TRANSISTOR		
Q440	UN2211-X	TRANSISTOR		
Q501	2SB1322/RS/-T	TRANSISTOR		
Q502	2SB1132/QR/-W	TRANSISTOR		
Q521	2SB1241/QR/-T	TRANSISTOR		
Q541	UN2111-X	TRANSISTOR		
Q542	UN2211-X	TRANSISTOR		
Q543	UN2111-X	TRANSISTOR		
Q544	2SB624/4/-X	TRANSISTOR		
Q545	UN2211-X	TRANSISTOR		
Q781	UN2111-X	TRANSISTOR		

△ Symbol No.	Part No.	Part Name	Description	Local
Q782	UN2211-X	TRANSISTOR		
Q784	UN2111-X	TRANSISTOR		
Q881	UN2211-X	TRANSISTOR		
Q891	UN2211-X	TRANSISTOR		
Q976	UN2211-X	TRANSISTOR		
Q977	2SB709A/QR/-X	TRANSISTOR		
D1	MA111-X	SI DIODE		
D2	MA111-X	SI DIODE		
D4	MA111-X	SI DIODE		
D5	MA111-X	SI DIODE		
D84	MA111-X	SI DIODE		G501 E,G50 1EX
D240	MA111-X	SI DIODE		
D241	MA111-X	SI DIODE		
D242	MA111-X	SI DIODE		
D243	RB160M-30-X	SB DIODE		
D244	UDZS5.1B-X	Z DIODE		
D321	MA111-X	SI DIODE		
D331	MA111-X	SI DIODE		
D341	MA111-X	SI DIODE		
D351	MA111-X	SI DIODE		
D481	UDZS5.1B-X	Z DIODE		
D701	MA8062/M/-X	Z DIODE		
D702	MA8062/M/-X	Z DIODE		
D703	MA8062/M/-X	Z DIODE		
D704	MA8062/M/-X	Z DIODE		
D705	MA8062/M/-X	Z DIODE		
D706	MA8062/M/-X	Z DIODE		
D707	MA8062/M/-X	Z DIODE		
D708	MA8062/M/-X	Z DIODE		
D709	MA8062/M/-X	Z DIODE		
D710	MA8062/M/-X	Z DIODE		
D711	MA8062/M/-X	Z DIODE		
D712	MA8062/M/-X	Z DIODE		G501 E,G50 1EX
D713	MA111-X	SI DIODE		
D714	UDZS5.6B-X	Z DIODE	1.5kΩ 1/10W J	
D715	SML-310VT/JK/-X	LED		G501 E,G50 1EX
D715	LNJ308G81/1-3/X	LED		G507 EE
D716	SML-310VT/JK/-X	LED		G501 E,G50 1EX
D716	LNJ308G81/1-3/X	LED		G507 EE
D717	SML-310VT/JK/-X	LED		G501 E,G50 1EX
D717	LNJ308G81/1-3/X	LED		G507 EE
D718	MA8062/M/-X	Z DIODE		
D781	MA111-X	SI DIODE		
D782	MA111-X	SI DIODE		
D784	UDZS11B-X	Z DIODE		
D891	MA111-X	SI DIODE		
D892	MA111-X	SI DIODE		
D901	1N5401-TU-15	DIODE		
D902	MA111-X	SI DIODE		
D971	RB160M-30-X	SB DIODE		
D972	RB160M-30-X	SB DIODE		
C1	QEKJ1CM-226Z	E CAPACITOR	22uF 16V M	
C2	NCB31EK-473X	C CAPACITOR	0.047uF 25V K	
C3	QEKJ1CM-226Z	E CAPACITOR	22uF 16V M	
C4	QEKJ1AM-227Z	E CAPACITOR	220uF 10V M	
C5	QEKJ1HM-104Z	E CAPACITOR	0.1uF 50V M	
C6	NCB31HK-103X	C CAPACITOR	0.01uF 50V K	
C9	QEKJ1AM-227Z	E CAPACITOR	220uF 10V M	
C31	QEKJ1AM-107Z	E CAPACITOR	100uF 10V M	
C32	NDC31HJ-470X	C CAPACITOR	47pF 50V J	
C33	QEKJ0JM-476Z	E CAPACITOR	47uF 6.3V M	
C34	NCB31EK-473X	C CAPACITOR	0.047uF 25V K	



△ Symbol No.	Part No.	Part Name	Description	Local	△ Symbol No.	Part No.	Part Name	Description	Local
C35	NDC31HJ-100X	C CAPACITOR	10pF 50V J		C167	NCB31EK-333X	C CAPACITOR	0.033uF 25V K	
C36	NDC31HJ-7R0X	C CAPACITOR	7pF 50V J		C168	NCB31HK-562X	C CAPACITOR	5600pF 50V K	
C37	NDC31HJ-100X	C CAPACITOR	10pF 50V J		C169	QEKJ1EM-475Z	E CAPACITOR	4.7uF 25V M	
C38	NCB31HK-102X	C CAPACITOR	1000pF 50V K		C170	QEKJ1EM-475Z	E CAPACITOR	4.7uF 25V M	
C39	NCB31HK-102X	C CAPACITOR	1000pF 50V K		C171	QEKJ1HM-105Z	E CAPACITOR	1uF 50V M	
C40	QEKJ1CM-106Z	E CAPACITOR	10uF 16V M		C172	QEKJ1HM-105Z	E CAPACITOR	1uF 50V M	
C41	NCB31EK-473X	C CAPACITOR	0.047uF 25V K		C173	QEKJ1HM-105Z	E CAPACITOR	1uF 50V M	
C42	NCB31HK-103X	C CAPACITOR	0.01uF 50V K	G501 E,G50 1EX	C174	NCB31HK-822X	C CAPACITOR	8200pF 50V K	
C42	NCB31EK-333X	C CAPACITOR	0.033uF 25V K	G507 EE	C175	NCB31CK-224X	C CAPACITOR	0.22uF 16V K	
C43	QFV61HJ-473Z	MF CAPACITOR	0.047uF 50V J		C176	NCB21CK-224X	C CAPACITOR	0.22uF 16V K	
C44	NCB31HK-103X	C CAPACITOR	0.01uF 50V K	G501 E,G50 1EX	C177	NCB31EK-333X	C CAPACITOR	0.033uF 25V K	
C44	NCB31EK-333X	C CAPACITOR	0.033uF 25V K	G507 EE	C178	NCB31HK-562X	C CAPACITOR	5600pF 50V K	
C45	NCB31HK-272X	C CAPACITOR	2700pF 50V K	G501 E,G50 1EX	C179	QEKJ1EM-475Z	E CAPACITOR	4.7uF 25V M	
C45	NCB31HK-682X	C CAPACITOR	6800pF 50V K	G507 EE	C180	QEKJ1EM-475Z	E CAPACITOR	4.7uF 25V M	
C46	NCB31HK-103X	C CAPACITOR	0.01uF 50V K		C191	QEKJ1CM-476Z	E CAPACITOR	47uF 16V M	
C47	NCB31HK-103X	C CAPACITOR	0.01uF 50V K		C192	QEKJ1CM-107Z	E CAPACITOR	100uF 16V M	
C48	NCB31EK-473X	C CAPACITOR	0.047uF 25V K		C193	QEKJ1CM-107Z	E CAPACITOR	100uF 16V M	
C49	NCB31HK-102X	C CAPACITOR	1000pF 50V K		C194	NCB31EK-103X	C CAPACITOR	0.01uF 25V K	
C50	NDC31HJ-101X	C CAPACITOR	100pF 50V J		C241	QEKJ1HM-105Z	E CAPACITOR	1uF 50V M	
C51	NDC31HJ-331X	C CAPACITOR	330pF 50V J		C242	QEKJ1CM-226Z	E CAPACITOR	22uF 16V M	
C52	NCB31HK-103X	C CAPACITOR	0.01uF 50V K	G501 E,G50 1EX	C243	NCB31EK-473X	C CAPACITOR	0.047uF 25V K	
C53	NCB31EK-472X	C CAPACITOR	4700pF 25V K	G501 E,G50 1EX	C245	NCB21CK-224X	C CAPACITOR	0.22uF 16V K	
C54	NCB31EK-104X	C CAPACITOR	0.1uF 25V K	G501 E,G50 1EX	C246	NCB31HK-103X	C CAPACITOR	0.01uF 50V K	
C55	QEKJ1HM-474Z	E CAPACITOR	0.47uF 50V M	G501 E,G50 1EX	C301	QFVD1HJ-474Z	MF CAPACITOR	0.47uF 50V J	
C71	NDC31HJ-561X	C CAPACITOR	560pF 50V J	G501 E,G50 1EX	C302	QFVD1HJ-474Z	MF CAPACITOR	0.47uF 50V J	
C72	NCB31EK-223X	C CAPACITOR	0.022uF 25V K	G501 E,G50 1EX	C303	NCS31HJ-391X	C CAPACITOR	390pF 50V J	
C73	QEKJ1HM-225Z	E CAPACITOR	2.2uF 50V M	G501 E,G50 1EX	C304	NCS31HJ-391X	C CAPACITOR	390pF 50V J	
C74	NDC31HJ-820X	C CAPACITOR	82pF 50V J	G501 E,G50 1EX	C307	QEKJ1HM-105Z	E CAPACITOR	1uF 50V M	
C75	NDC31HJ-470X	C CAPACITOR	47pF 50V J	G501 E,G50 1EX	C308	QEKJ1HM-105Z	E CAPACITOR	1uF 50V M	
C76	NCB31HK-103X	C CAPACITOR	0.01uF 50V K	G501 E,G50 1EX	C311	QFVD1HJ-474Z	MF CAPACITOR	0.47uF 50V J	
C77	QEKJ0JM-476Z	E CAPACITOR	47uF 6.3V M	G501 E,G50 1EX	C312	QFVD1HJ-474Z	MF CAPACITOR	0.47uF 50V J	
C78	NCB31HK-103X	C CAPACITOR	0.01uF 50V K	G501 E,G50 1EX	C313	NCS31HJ-391X	C CAPACITOR	390pF 50V J	
C81	QEKJ1HM-105Z	E CAPACITOR	1uF 50V M	G501 E,G50 1EX	C314	NCS31HJ-391X	C CAPACITOR	390pF 50V J	
C82	NCB31HK-152X	C CAPACITOR	1500pF 50V K	G501 E,G50 1EX	C315	QEKJ1HM-475Z	E CAPACITOR	4.7uF 50V M	
C83	NCB31EK-104X	C CAPACITOR	0.1uF 25V K	G501 E,G50 1EX	C316	QEKJ1EM-475Z	E CAPACITOR	4.7uF 25V M	
C84	NCB31HK-123X	C CAPACITOR	0.012uF 50V K		C317	QEKJ1CM-476Z	E CAPACITOR	47uF 16V M	
C85	NCB31HK-102X	C CAPACITOR	1000pF 50V K		C318	QEDJ1CM-226Z	E CAPACITOR	22uF 16V M	
C91	QEKJ1HM-105Z	E CAPACITOR	1uF 50V M		C319	NCB31EK-223X	C CAPACITOR	0.022uF 25V K	
C92	NCB31HK-152X	C CAPACITOR	1500pF 50V K		C320	NCB31EK-223X	C CAPACITOR	0.022uF 25V K	
C94	NCB31HK-123X	C CAPACITOR	0.012uF 50V K		C321	NCB31EK-473X	C CAPACITOR	0.047uF 25V K	
C95	NCB31HK-102X	C CAPACITOR	1000pF 50V K		C322	NCB31EK-104X	C CAPACITOR	0.1uF 25V K	
C161	QEKJ1HM-105Z	E CAPACITOR	1uF 50V M		C323	NCB31EK-104X	C CAPACITOR	0.1uF 25V K	
C162	QEKJ1HM-105Z	E CAPACITOR	1uF 50V M		C324	NCB31EK-104X	C CAPACITOR	0.1uF 25V K	
C163	QEKJ1HM-105Z	E CAPACITOR	1uF 50V M		C325	NCB31EK-104X	C CAPACITOR	0.1uF 25V K	
C164	NCB31HK-822X	C CAPACITOR	8200pF 50V K		C341	NCB31EK-473X	C CAPACITOR	0.047uF 25V K	
C165	NCB31CK-224X	C CAPACITOR	0.22uF 16V K		C402	NCB31HK-103X	C CAPACITOR	0.01uF 50V K	
C166	NCB21CK-224X	C CAPACITOR	0.22uF 16V K		C403	NCB31HK-103X	C CAPACITOR	0.01uF 50V K	
					C404	NCB31HK-103X	C CAPACITOR	0.01uF 50V K	
					C405	QEKJ1HM-105Z	E CAPACITOR	1uF 50V M	
					C407	QEKJ1AM-107Z	E CAPACITOR	100uF 10V M	
					C408	NCB31HK-103X	C CAPACITOR	0.01uF 50V K	
					C409	NDC31HJ-101X	C CAPACITOR	100pF 50V J	
					C411	QEKJ1AM-107Z	E CAPACITOR	100uF 10V M	
					C412	NCB31HK-103X	C CAPACITOR	0.01uF 50V K	
					C413	NCB31EK-104X	C CAPACITOR	0.1uF 25V K	
					C414	NCB31HK-222X	C CAPACITOR	2200pF 50V K	
					C415	NCB31EK-104X	C CAPACITOR	0.1uF 25V K	
					C416	NCB31HK-103X	C CAPACITOR	0.01uF 50V K	
					C418	NCB31HK-103X	C CAPACITOR	0.01uF 50V K	
					C419	NDC31HJ-120X	C CAPACITOR	12pF 50V J	
					C420	NDC31HJ-120X	C CAPACITOR	12pF 50V J	
					C421	NCB31HK-103X	C CAPACITOR	0.01uF 50V K	
					C422	QEKJ0JM-107Z	E CAPACITOR	100uF 6.3V M	
					C430	NCB31HK-103X	C CAPACITOR	0.01uF 50V K	
					C431	NDC31HJ-101X	C CAPACITOR	0.01pF 50V J	
					C440	NCB31HK-103X	C CAPACITOR	0.01uF 50V K	
					C461	NCB31EK-104X	C CAPACITOR	0.1uF 25V K	
					C462	QEKJ0JM-107Z	E CAPACITOR	100uF 6.3V M	
					C463	QEKJ0JM-107Z	E CAPACITOR	100uF 6.3V M	
					C464	NCB31EK-104X	C CAPACITOR	0.1uF 25V K	
					C481	QEKJ1CM-476Z	E CAPACITOR	47uF 16V M	
					C482	NCB31EK-104X	C CAPACITOR	0.1uF 25V K	
					C483	NCB31EK-104X	C CAPACITOR	0.1uF 25V K	
					C501	QEDJ1AM-476Z	E CAPACITOR	47uF 10V M	
					C502	NCB31HK-103X	C CAPACITOR	0.01uF 50V K	
					C503	QEKJ1AM-107Z	E CAPACITOR	100uF 10V M	
					C504	NCB31EK-473X	C CAPACITOR	0.047uF 25V K	
					C505	NCB31EK-473X	C CAPACITOR	0.047uF 25V K	

△ Symbol No.	Part No.	Part Name	Description	Local	△ Symbol No.	Part No.	Part Name	Description	Local
C506	NCB31EK-473X	C CAPACITOR	0.047uF 25V K		C717	NCB31EK-104X	C CAPACITOR	0.1uF 25V K	
C507	NCB31EK-473X	C CAPACITOR	0.047uF 25V K		C718	NDC31HJ-101X	C CAPACITOR	100pF 50V J	G501 E,G50 1EX
C508	NCB31HK-103X	C CAPACITOR	0.01uF 50V K		C771	NCB31EK-473X	C CAPACITOR	0.047uF 25V K	G501 E,G50 1EX
C512	NCB31HK-103X	C CAPACITOR	0.01uF 50V K		C781	QEKJ0JM-107Z	E CAPACITOR	100uF 6.3V M	
C513	NCB31EK-104X	C CAPACITOR	0.1uF 25V K	G507 EE	C782	NCB31EK-823X	C CAPACITOR	0.082uF 25V K	
C521	NCB31HK-103X	C CAPACITOR	0.01uF 50V K		C783	NCB31EK-103X	C CAPACITOR	0.01uF 25V K	
C522	NCB31HK-103X	C CAPACITOR	0.01uF 50V K		C784	QEKJ1CM-107Z	E CAPACITOR	100uF 16V M	
C523	QEKJ1AM-107Z	E CAPACITOR	100uF 10V M		C801	NCB31EK-473X	C CAPACITOR	0.047uF 25V K	
C524	NCB31HK-103X	C CAPACITOR	0.01uF 50V K		C881	QEKJ1CM-226Z	E CAPACITOR	22uF 16V M	
C525	QEKJ1AM-107Z	E CAPACITOR	100uF 10V M		C891	NCB31EK-104X	C CAPACITOR	0.1uF 25V K	
C527	NCB31HK-682X	C CAPACITOR	6800pF 50V K		C901	QEZ0625-338	E CAPACITOR	3300uF	G501 E,G50 1EX
C528	NCB31HK-103X	C CAPACITOR	0.01uF 50V K		C901	QEZ0675-338	E CAPACITOR	3300uF	G507 EE
C529	QERF1AM-107Z	E CAPACITOR	100uF 10V M		C902	QEKJ1HM-225Z	E CAPACITOR	2.2uF 50V M	
C530	NCB31EK-104X	C CAPACITOR	0.1uF 25V K		C903	QEKJ1CM-476Z	E CAPACITOR	47uF 16V M	
C531	NCB31EK-104X	C CAPACITOR	0.1uF 25V K		C904	QEKJ1CM-106Z	E CAPACITOR	10uF 16V M	
C532	NDC31HJ-680X	C CAPACITOR	68pF 50V J		C905	QEKJ1CM-476Z	E CAPACITOR	47uF 16V M	
C533	NCB31HK-103X	C CAPACITOR	0.01uF 50V K		C906	NCB31HK-103X	C CAPACITOR	0.01uF 50V K	
C534	NDC31HJ-5R0X	C CAPACITOR	5pF 50V J		C907	QEKJ1AM-227Z	E CAPACITOR	220uF 10V M	
C541	QEKJ1AM-107Z	E CAPACITOR	100uF 10V M		C908	QEKJ1AM-227Z	E CAPACITOR	220uF 10V M	
C542	NCB31HK-103X	C CAPACITOR	0.01uF 50V K		C909	QEKJ1AM-227Z	E CAPACITOR	220uF 10V M	
C543	QEKJ1HM-105Z	E CAPACITOR	1uF 50V M		C910	QEKJ1CM-106Z	E CAPACITOR	10uF 16V M	
C544	QEKJ0JM-107Z	E CAPACITOR	100uF 6.3V M		C911	NCB31CK-104X	C CAPACITOR	0.1uF 16V K	
C545	NCB31HK-103X	C CAPACITOR	0.01uF 50V K		C912	NCB31HK-103X	C CAPACITOR	0.01uF 50V K	
C546	NDC31HJ-470X	C CAPACITOR	47pF 50V J		C913	QEKJ1CM-106Z	E CAPACITOR	10uF 16V M	
C547	NCB31HK-153X	C CAPACITOR	0.015uF 50V K		C914	QEKJ1CM-107Z	E CAPACITOR	100uF 16V M	
C548	NCB31HK-103X	C CAPACITOR	0.01uF 50V K		C915	NCB31CK-104X	C CAPACITOR	0.1uF 16V K	
C549	NCB31HK-272X	C CAPACITOR	2700pF 50V K		C961	NDC31HJ-101X	C CAPACITOR	100pF 50V J	
C550	NCB31HK-103X	C CAPACITOR	0.01uF 50V K		C962	NDC31HJ-101X	C CAPACITOR	100pF 50V J	
C551	NCB31EK-333X	C CAPACITOR	0.033uF 25V K		C963	NDC31HJ-101X	C CAPACITOR	100pF 50V J	
C552	NCB31EK-333X	C CAPACITOR	0.033uF 25V K		C964	NDC31HJ-101X	C CAPACITOR	100pF 50V J	
C553	NCB31EK-473X	C CAPACITOR	0.047uF 25V K		C965	NDC31HJ-101X	C CAPACITOR	100pF 50V J	
C554	NCB31EK-473X	C CAPACITOR	0.047uF 25V K		C966	NDC31HJ-101X	C CAPACITOR	100pF 50V J	
C555	NCB31EK-473X	C CAPACITOR	0.047uF 25V K		C967	NDC31HJ-101X	C CAPACITOR	100pF 50V J	
C556	NCB31HK-471X	C CAPACITOR	470pF 50V K		C968	NDC31HJ-101X	C CAPACITOR	100pF 50V J	
C557	NCB31HK-471X	C CAPACITOR	470pF 50V K		C971	NCB31EK-104X	C CAPACITOR	0.1uF 25V K	
C558	NCB31EK-473X	C CAPACITOR	0.047uF 25V K		C990	NCB31HK-103X	C CAPACITOR	0.01uF 50V K	
C559	NCB31EK-473X	C CAPACITOR	0.047uF 25V K		C991	NCB31HK-103X	C CAPACITOR	0.01uF 50V K	
C560	NCB31HK-103X	C CAPACITOR	0.01uF 50V K		R1	NRS181J-100X	MG RESISTOR	10Ω 1/8W J	
C561	QEKJ0JM-107Z	E CAPACITOR	100uF 6.3V M		R2	NRSA63J-473X	MG RESISTOR	47kΩ 1/16W J	
C562	NCB31HK-103X	C CAPACITOR	0.01uF 50V K		R3	NRSA63J-472X	MG RESISTOR	4.7kΩ 1/16W J	G501 E,G50 1EX
C565	NCB31HK-103X	C CAPACITOR	0.01uF 50V K		R4	NRSA63J-332X	MG RESISTOR	3.3kΩ 1/16W J	
C566	QEKJ0JM-107Z	E CAPACITOR	100uF 6.3V M		R5	NRSA63J-473X	MG RESISTOR	47kΩ 1/16W J	
C568	NCB31EK-104X	C CAPACITOR	0.1uF 25V K		R6	NRSA63J-473X	MG RESISTOR	47kΩ 1/16W J	
C569	NCB31HK-103X	C CAPACITOR	0.01uF 50V K		R7	NRSA63J-472X	MG RESISTOR	4.7kΩ 1/16W J	
C570	QEKJ0JM-107Z	E CAPACITOR	100uF 6.3V M		R9	NRSA63J-0R0X	MG RESISTOR	0Ω 1/16W J	G501 E,G50 1EX
C571	NCB31HK-103X	C CAPACITOR	0.01uF 50V K		R9	NRSA63J-680X	MG RESISTOR	68Ω 1/16W J	G507 EE
C572	QEKJ0JM-107Z	E CAPACITOR	100uF 6.3V M		R10	NRSA63J-103X	MG RESISTOR	10kΩ 1/16W J	
C580	QEKJ1EM-475Z	E CAPACITOR	4.7uF 25V M		R11	NRSA63J-103X	MG RESISTOR	10kΩ 1/16W J	
C581	NCB31HK-332X	C CAPACITOR	3300pF 50V K		R12	NRSA63J-0R0X	MG RESISTOR	0Ω 1/16W J	G507 EE
C582	NDC31HJ-271X	C CAPACITOR	270pF 50V J		R31	NRS181J-100X	MG RESISTOR	10Ω 1/8W J	
C583	NDC31HJ-271X	C CAPACITOR	270pF 50V J		R32	NRSA63J-622X	MG RESISTOR	6.2kΩ 1/16W J	
C584	NCB31EK-104X	C CAPACITOR	0.1uF 25V K		R33	NRSA63J-103X	MG RESISTOR	10kΩ 1/16W J	
C585	QEKJ0JM-476Z	E CAPACITOR	47uF 6.3V M		R38	NRSA63J-101X	MG RESISTOR	100Ω 1/16W J	
C589	QEKJ1EM-475Z	E CAPACITOR	4.7uF 25V M		R39	NRSA63J-0R0X	MG RESISTOR	0Ω 1/16W J	
C590	QEKJ1EM-475Z	E CAPACITOR	4.7uF 25V M		R40	NRSA63J-393X	MG RESISTOR	39kΩ 1/16W J	
C591	NCB31HK-332X	C CAPACITOR	3300pF 50V K		R41	NRSA63J-103X	MG RESISTOR	10kΩ 1/16W J	G501 E,G50 1EX
C592	NDC31HJ-271X	C CAPACITOR	270pF 50V J		R41	NRSA63J-392X	MG RESISTOR	3.9kΩ 1/16W J	G507 EE
C593	NDC31HJ-271X	C CAPACITOR	270pF 50V J		R42	NRS181J-100X	MG RESISTOR	10Ω 1/8W J	
C594	NCB31EK-104X	C CAPACITOR	0.1uF 25V K		R43	NRSA63J-471X	MG RESISTOR	470Ω 1/16W J	
C595	QEKJ0JM-476Z	E CAPACITOR	47uF 6.3V M		R44	NRSA63J-221X	MG RESISTOR	220Ω 1/16W J	
C596	QEKJ1AM-107Z	E CAPACITOR	100uF 10V M		R51	NRSA63J-273X	MG RESISTOR	27kΩ 1/16W J	
C597	NCB31HK-103X	C CAPACITOR	0.01uF 50V K						
C599	QEKJ1EM-475Z	E CAPACITOR	4.7uF 25V M						
C701	NDC31HJ-220X	C CAPACITOR	22pF 50V J						
C702	NDC31HJ-270X	C CAPACITOR	27pF 50V J						
C703	NDC31HJ-270X	C CAPACITOR	27pF 50V J						
C704	NDC31HJ-8R0X	C CAPACITOR	8pF 50V J						
C705	NCB31EK-473X	C CAPACITOR	0.047uF 25V K						
C706	NCB31EK-473X	C CAPACITOR	0.047uF 25V K						
C707	NCB31EK-473X	C CAPACITOR	0.047uF 25V K						
C708	NCB31EK-473X	C CAPACITOR	0.047uF 25V K						
C709	NCB31HK-103X	C CAPACITOR	0.01uF 50V K						
C710	QEKJ0JM-476Z	E CAPACITOR	47uF 6.3V M						
C711	QEKJ1AM-227Z	E CAPACITOR	220uF 10V M						
C712	NCB31HK-103X	C CAPACITOR	0.01uF 50V K						
C713	NCB31EK-103X	C CAPACITOR	0.01uF 25V K						
C716	NCB31EK-104X	C CAPACITOR	0.1uF 25V K						

△ Symbol No.	Part No.	Part Name	Description	Local	△ Symbol No.	Part No.	Part Name	Description	Local
R52	NRSA63J-473X	MG RESISTOR	47kΩ 1/16W J	G501 E,G50 1EX	R402	NRSA63J-470X	MG RESISTOR	47Ω 1/16W J	
R53	NRSA63J-473X	MG RESISTOR	47kΩ 1/16W J	G501 E,G50 1EX	R403	NRSA63J-105X	MG RESISTOR	1MΩ 1/16W J	
R54	NRSA63J-103X	MG RESISTOR	10kΩ 1/16W J	G501 E,G50 1EX	R404	NRSA63J-103X	MG RESISTOR	10kΩ 1/16W J	
R55	NRSA63J-222X	MG RESISTOR	2.2kΩ 1/16W J	G501 E,G50 1EX	R405	NRSA63J-222X	MG RESISTOR	2.2kΩ 1/16W J	
R56	NRSA63J-103X	MG RESISTOR	10kΩ 1/16W J	G501 E,G50 1EX	R406	NRSA63J-470X	MG RESISTOR	47Ω 1/16W J	
R57	NRSA63J-153X	MG RESISTOR	15kΩ 1/16W J	G501 E,G50 1EX	R407	NRSA63J-222X	MG RESISTOR	2.2kΩ 1/16W J	
R58	NRSA63J-471X	MG RESISTOR	470Ω 1/16W J	G501 E,G50 1EX	R408	NRSA63J-222X	MG RESISTOR	2.2kΩ 1/16W J	
R59	NRSA63J-473X	MG RESISTOR	47kΩ 1/16W J	G501 E,G50 1EX	R409	NRSA63J-222X	MG RESISTOR	2.2kΩ 1/16W J	
R71	NRSA63J-222X	MG RESISTOR	2.2kΩ 1/16W J	G501 E,G50 1EX	R412	NRSA63J-472X	MG RESISTOR	4.7kΩ 1/16W J	
R72	NRSA63J-222X	MG RESISTOR	2.2kΩ 1/16W J	G501 E,G50 1EX	R413	NRSA63J-472X	MG RESISTOR	4.7kΩ 1/16W J	
R73	NRSA63J-222X	MG RESISTOR	2.2kΩ 1/16W J	G501 E,G50 1EX	R414	NRSA63J-472X	MG RESISTOR	4.7kΩ 1/16W J	
R74	NRSA02J-101X	MG RESISTOR	100Ω 1/10W J	G501 E,G50 1EX	R415	NRSA63J-222X	MG RESISTOR	2.2kΩ 1/16W J	
R81	NRSA63J-822X	MG RESISTOR	8.2kΩ 1/16W J	G501 E,G50 1EX	R416	NRSA63J-473X	MG RESISTOR	47kΩ 1/16W J	
R82	NRSA63J-183X	MG RESISTOR	18kΩ 1/16W J	G501 E,G50 1EX	R423	NRSA63J-103X	MG RESISTOR	10kΩ 1/16W J	
R83	NRSA63J-472X	MG RESISTOR	4.7kΩ 1/16W J	G501 E,G50 1EX	R424	NRSA63J-221X	MG RESISTOR	220Ω 1/16W J	
R84	NRSA63J-0R0X	MG RESISTOR	0Ω 1/16W J	G501 E,G50 1EX	R430	NRSA63J-472X	MG RESISTOR	4.7kΩ 1/16W J	
R91	NRSA63J-822X	MG RESISTOR	8.2kΩ 1/16W J	G501 E,G50 1EX	R431	NRSA63J-103X	MG RESISTOR	10kΩ 1/16W J	
R92	NRSA63J-183X	MG RESISTOR	18kΩ 1/16W J	G501 E,G50 1EX	R432	NRSA63J-682X	MG RESISTOR	6.8kΩ 1/16W J	
R93	NRSA63J-472X	MG RESISTOR	4.7kΩ 1/16W J	G501 E,G50 1EX	R433	NRSA63J-101X	MG RESISTOR	100Ω 1/16W J	
R161	NRSA63J-224X	MG RESISTOR	220kΩ 1/16W J	G501 E,G50 1EX	R440	NRSA63J-472X	MG RESISTOR	4.7kΩ 1/16W J	
R162	NRSA63J-223X	MG RESISTOR	22kΩ 1/16W J	G501 E,G50 1EX	R451	NRSA63J-223X	MG RESISTOR	22kΩ 1/16W J	
R163	NRSA63J-222X	MG RESISTOR	2.2kΩ 1/16W J	G501 E,G50 1EX	R452	NRSA63J-473X	MG RESISTOR	47kΩ 1/16W J	
R164	NRSA63J-473X	MG RESISTOR	47kΩ 1/16W J	G501 E,G50 1EX	R453	NRSA63J-222X	MG RESISTOR	2.2kΩ 1/16W J	
R165	NRSA63J-473X	MG RESISTOR	47kΩ 1/16W J	G501 E,G50 1EX	R454	NRSA63J-472X	MG RESISTOR	4.7kΩ 1/16W J	
R171	NRSA63J-224X	MG RESISTOR	220kΩ 1/16W J	G501 E,G50 1EX	R455	NRSA63J-222X	MG RESISTOR	2.2kΩ 1/16W J	
R172	NRSA63J-223X	MG RESISTOR	22kΩ 1/16W J	G501 E,G50 1EX	R456	NRSA63J-472X	MG RESISTOR	4.7kΩ 1/16W J	
R173	NRSA63J-222X	MG RESISTOR	2.2kΩ 1/16W J	G501 E,G50 1EX	R457	NRSA63J-222X	MG RESISTOR	2.2kΩ 1/16W J	
R174	NRSA63J-473X	MG RESISTOR	47kΩ 1/16W J	G501 E,G50 1EX	R458	NRSA63J-472X	MG RESISTOR	4.7kΩ 1/16W J	
R175	NRSA63J-473X	MG RESISTOR	47kΩ 1/16W J	G501 E,G50 1EX	R459	NRSA02J-101X	MG RESISTOR	100Ω 1/10W J	
R181	NRSA63J-271X	MG RESISTOR	270Ω 1/16W J	G501 E,G50 1EX	R460	NRSA02J-101X	MG RESISTOR	100Ω 1/10W J	
R182	NRSA63J-271X	MG RESISTOR	270Ω 1/16W J	G501 E,G50 1EX	R481	NRSA02J-181X	MG RESISTOR	180Ω 1/10W J	
R241	NRSA63J-473X	MG RESISTOR	47kΩ 1/16W J	G501 E,G50 1EX	R501	NRSA63J-333X	MG RESISTOR	33kΩ 1/16W J	
R242	NRSA63J-223X	MG RESISTOR	22kΩ 1/16W J	G501 E,G50 1EX	R502	NRSA63J-822X	MG RESISTOR	8.2kΩ 1/16W J	
R243	NRSA63J-184X	MG RESISTOR	180kΩ 1/16W J	G501 E,G50 1EX	R503	NRSA63J-472X	MG RESISTOR	4.7kΩ 1/16W J	
R244	NRSA63J-123X	MG RESISTOR	12kΩ 1/16W J	G501 E,G50 1EX	R504	NRSA63J-153X	MG RESISTOR	15kΩ 1/16W J	
R245	NRSA63J-470X	MG RESISTOR	47Ω 1/16W J	G501 E,G50 1EX	R507	NRSA63J-682X	MG RESISTOR	6.8kΩ 1/16W J	
R246	NRSA63J-102X	MG RESISTOR	1kΩ 1/16W J	G501 E,G50 1EX	R508	NRSA63J-302X	MG RESISTOR	3kΩ 1/16W J	
R247	NRSA63J-473X	MG RESISTOR	47kΩ 1/16W J	G501 E,G50 1EX	R509	NRSA63J-123X	MG RESISTOR	12kΩ 1/16W J	
R248	NRSA63J-221X	MG RESISTOR	220Ω 1/16W J	G501 E,G50 1EX	R510	NRSA63J-822X	MG RESISTOR	8.2kΩ 1/16W J	
R301	NRSA63J-273X	MG RESISTOR	27kΩ 1/16W J	G501 E,G50 1EX	R511	NRSA63J-152X	MG RESISTOR	1.5kΩ 1/16W J	
R302	NRSA63J-273X	MG RESISTOR	27kΩ 1/16W J	G501 E,G50 1EX	R512	NRSA63J-152X	MG RESISTOR	1.5kΩ 1/16W J	
R311	NRSA63J-273X	MG RESISTOR	27kΩ 1/16W J	G501 E,G50 1EX	R513	NRSA63J-152X	MG RESISTOR	1.5kΩ 1/16W J	
R312	NRSA63J-273X	MG RESISTOR	27kΩ 1/16W J	G501 E,G50 1EX	R514	NRSA02J-220X	MG RESISTOR	22Ω 1/10W J	
R321	NRSA63J-222X	MG RESISTOR	2.2kΩ 1/16W J	G501 E,G50 1EX	R515	NRSA02J-220X	MG RESISTOR	22Ω 1/10W J	
R322	NRSA63J-821X	MG RESISTOR	820Ω 1/16W J	G501 E,G50 1EX	R516	NRSA02J-331X	MG RESISTOR	330Ω 1/10W J	
R323	NRSA02J-101X	MG RESISTOR	100Ω 1/10W J	G501 E,G50 1EX	R517	NRSA02J-512X	MG RESISTOR	5.1kΩ 1/10W J	G507 EE
R331	NRSA63J-222X	MG RESISTOR	2.2kΩ 1/16W J	G501 E,G50 1EX	R518	NRSA02J-0R0X	MG RESISTOR	0Ω 1/10W J	G501 E,G50 1EX G507 EE
R332	NRSA63J-821X	MG RESISTOR	820Ω 1/16W J	G501 E,G50 1EX	R518	NRSA02J-822X	MG RESISTOR	8.2kΩ 1/10W J	
R333	NRSA02J-101X	MG RESISTOR	100Ω 1/10W J	G501 E,G50 1EX	R523	NRSA63J-823X	MG RESISTOR	82kΩ 1/16W J	
R341	NRSA63J-222X	MG RESISTOR	2.2kΩ 1/16W J	G501 E,G50 1EX	R524	NRSA63J-823X	MG RESISTOR	82kΩ 1/16W J	
R342	NRSA63J-821X	MG RESISTOR	820Ω 1/16W J	G501 E,G50 1EX	R525	NRSA63J-334X	MG RESISTOR	330kΩ 1/16W J	
R343	NRSA02J-101X	MG RESISTOR	100Ω 1/10W J	G501 E,G50 1EX	R526	NRSA63J-334X	MG RESISTOR	330kΩ 1/16W J	
R351	NRSA63J-222X	MG RESISTOR	2.2kΩ 1/16W J	G501 E,G50 1EX	R527	NRSA02J-220X	MG RESISTOR	22Ω 1/10W J	
R352	NRSA63J-821X	MG RESISTOR	820Ω 1/16W J	G501 E,G50 1EX	R528	NRSA02J-220X	MG RESISTOR	22Ω 1/10W J	
R353	NRSA02J-101X	MG RESISTOR	100Ω 1/10W J	G501 E,G50 1EX	R529	NRSA63J-823X	MG RESISTOR	82kΩ 1/16W J	
					R530	NRSA63J-563X	MG RESISTOR	56kΩ 1/16W J	
					R531	NRSA63J-103X	MG RESISTOR	10kΩ 1/16W J	
					R532	NRSA63J-202X	MG RESISTOR	2kΩ 1/16W J	
					R533	NRSA63J-102X	MG RESISTOR	1kΩ 1/16W J	
					R534	NRSA63J-153X	MG RESISTOR	15kΩ 1/16W J	
					R535	NRSA63J-101X	MG RESISTOR	100Ω 1/16W J	
					R536	NRSA63J-821X	MG RESISTOR	820Ω 1/16W J	
					R537	NRSA63J-0R0X	MG RESISTOR	0Ω 1/16W J	
					R539	NRSA02J-151X	MG RESISTOR	150Ω 1/10W J	
					R541	NRSA63J-562X	MG RESISTOR	5.6kΩ 1/16W J	
					R542	NRSA63J-473X	MG RESISTOR	47kΩ 1/16W J	
					R543	NRSA63J-474X	MG RESISTOR	470kΩ 1/16W J	
					R544	NRSA63J-103X	MG RESISTOR	10kΩ 1/16W J	
					R545	NRSA63J-103X	MG RESISTOR	10kΩ 1/16W J	
					R546	NRSA63J-0R0X	MG RESISTOR	0Ω 1/16W J	
					R547	NRSA63J-0R0X	MG RESISTOR	0Ω 1/16W J	
					R548	NRSA63J-0R0X	MG RESISTOR	0Ω 1/16W J	
					R549	NRSA63J-101X	MG RESISTOR	100Ω 1/16W J	
					R550	NRSA63J-101X	MG RESISTOR	100Ω 1/16W J	
					R551	NRSA63J-101X	MG RESISTOR	100Ω 1/16W J	

△ Symbol No.	Part No.	Part Name	Description	Local	△ Symbol No.	Part No.	Part Name	Description	Local
R552	NRSA63J-101X	MG RESISTOR	100Ω 1/16W J						
R553	NRSA63J-105X	MG RESISTOR	1MΩ 1/16W J		R767	NRSA63J-223X	MG RESISTOR	22kΩ 1/16W J	G501 E,G50 1EX
R558	NRSA63J-103X	MG RESISTOR	10kΩ 1/16W J						
R559	NRSA63J-155X	MG RESISTOR	1.5MΩ 1/16W J		R768	NRSA02J-271X	MG RESISTOR	270Ω 1/10W J	
R581	NRSA63J-822X	MG RESISTOR	8.2kΩ 1/16W J						G501 E,G50 1EX
R582	NRSA63J-822X	MG RESISTOR	8.2kΩ 1/16W J		R771	NRSA63J-271X	MG RESISTOR	270Ω 1/16W J	
R583	NRSA63J-822X	MG RESISTOR	8.2kΩ 1/16W J						G501 E,G50 1EX
R584	NRSA63J-181X	MG RESISTOR	180Ω 1/16W J		R772	NRSA63J-271X	MG RESISTOR	270Ω 1/16W J	
R585	NRSA63J-181X	MG RESISTOR	180Ω 1/16W J						
R586	NRSA63J-682X	MG RESISTOR	6.8kΩ 1/16W J		R776	NRSA63J-473X	MG RESISTOR	47kΩ 1/16W J	
R587	NRSA63J-102X	MG RESISTOR	1kΩ 1/16W J		R777	NRSA63J-473X	MG RESISTOR	47kΩ 1/16W J	
R588	NRSA63J-102X	MG RESISTOR	1kΩ 1/16W J		R783	NRSA63J-103X	MG RESISTOR	10kΩ 1/16W J	
R591	NRSA63J-822X	MG RESISTOR	8.2kΩ 1/16W J		R793	NRS181J-0R0X	MG RESISTOR	0Ω 1/8W J	
R592	NRSA63J-822X	MG RESISTOR	8.2kΩ 1/16W J		R801	NRSA63J-473X	MG RESISTOR	47kΩ 1/16W J	
R593	NRSA63J-822X	MG RESISTOR	8.2kΩ 1/16W J		R802	NRSA63J-473X	MG RESISTOR	47kΩ 1/16W J	
R594	NRSA63J-181X	MG RESISTOR	180Ω 1/16W J		R803	NRSA63J-101X	MG RESISTOR	100Ω 1/16W J	
R595	NRSA63J-181X	MG RESISTOR	180Ω 1/16W J		R804	NRSA63J-223X	MG RESISTOR	22kΩ 1/16W J	
R596	NRSA63J-682X	MG RESISTOR	6.8kΩ 1/16W J		R805	NRSA63J-104X	MG RESISTOR	100kΩ 1/16W J	
R597	NRSA63J-102X	MG RESISTOR	1kΩ 1/16W J		R806	NRSA63J-103X	MG RESISTOR	10kΩ 1/16W J	
R598	NRSA63J-102X	MG RESISTOR	1kΩ 1/16W J		R807	NRSA63J-104X	MG RESISTOR	100kΩ 1/16W J	
R701	NRSA63J-473X	MG RESISTOR	47kΩ 1/16W J		R808	NRSA63J-331X	MG RESISTOR	330Ω 1/16W J	
R702	NRSA63J-0R0X	MG RESISTOR	0Ω 1/16W J		R809	NRSA63J-223X	MG RESISTOR	22kΩ 1/16W J	
R704	NRSA63J-473X	MG RESISTOR	47kΩ 1/16W J		R810	NRSA63J-101X	MG RESISTOR	100Ω 1/16W J	
R705	NRSA63J-473X	MG RESISTOR	47kΩ 1/16W J		R881	NRSA63J-473X	MG RESISTOR	47kΩ 1/16W J	
R708	NRSA63J-332X	MG RESISTOR	3.3kΩ 1/16W J		R882	NRSA63J-472X	MG RESISTOR	4.7kΩ 1/16W J	
R713	NRSA63J-101X	MG RESISTOR	100Ω 1/16W J		R891	NRSA63J-102X	MG RESISTOR	1kΩ 1/16W J	
R714	NRSA63J-103X	MG RESISTOR	10kΩ 1/16W J		R892	NRSA63J-473X	MG RESISTOR	47kΩ 1/16W J	
R715	NRSA63J-102X	MG RESISTOR	1kΩ 1/16W J		R901	QRE142J-102X	C RESISTOR	1kΩ 1/4W J	
R716	NRSA63J-102X	MG RESISTOR	1kΩ 1/16W J		R902	NRSA02J-912X	MG RESISTOR	9.1kΩ 1/10W J	
R717	NRSA63J-103X	MG RESISTOR	10kΩ 1/16W J		R903	NRSA02J-472X	MG RESISTOR	4.7kΩ 1/10W J	
R718	NRSA63J-103X	MG RESISTOR	10kΩ 1/16W J		R971	NRS181J-222X	MG RESISTOR	2.2kΩ 1/8W J	
R719	NRSA63J-0R0X	MG RESISTOR	0Ω 1/16W J		R972	NRS181J-222X	MG RESISTOR	2.2kΩ 1/8W J	
R720	NRSA63J-122X	MG RESISTOR	1.2kΩ 1/16W J		R976	NRSA02J-273X	MG RESISTOR	27kΩ 1/10W J	
R721	NRSA63J-102X	MG RESISTOR	1kΩ 1/16W J		R977	NRSA02J-123X	MG RESISTOR	12kΩ 1/10W J	
R722	NRSA63J-103X	MG RESISTOR	10kΩ 1/16W J		RA30	NRZ0065-222X	NET RESISTOR	2.2kΩ	
R723	NRSA63J-103X	MG RESISTOR	10kΩ 1/16W J		RA550	NRZ0065-103X	NET RESISTOR	10kΩ	
R725	NRSA63J-103X	MG RESISTOR	10kΩ 1/16W J		RA701	NRZ0065-102X	NET RESISTOR	1kΩ	
R726	NRSA63J-103X	MG RESISTOR	10kΩ 1/16W J						
R728	NRSA63J-103X	MG RESISTOR	10kΩ 1/16W J		L1	QQL244J-4R7Z	INDUCTIOR	4.7uH J	
R729	NRSA63J-473X	MG RESISTOR	47kΩ 1/16W J		L401	NQL114K-470X	COIL	47uH K	
R730	NRSA63J-103X	MG RESISTOR	10kΩ 1/16W J		L402	NQL114K-470X	COIL	47uH K	
R731	NRSA63J-473X	MG RESISTOR	47kΩ 1/16W J		L404	NQL114K-470X	COIL	47uH K	
					L541	NQL114K-470X	COIL	47uH K	
R732	NRSA63J-103X	MG RESISTOR	10kΩ 1/16W J	G501 E,G50 1EX	L543	NQL114K-470X	COIL	47uH K	
					L544	NQL114K-470X	COIL	47uH K	
R734	NRSA63J-222X	MG RESISTOR	2.2kΩ 1/16W J		L701	NQL114M-4R7X	COIL	4.7uH M	
R735	NRSA63J-222X	MG RESISTOR	2.2kΩ 1/16W J		L702	NQL114M-4R7X	COIL	4.7uH M	
R736	NRSA63J-222X	MG RESISTOR	2.2kΩ 1/16W J		L901	QQR1378-002	CHOKE COIL		
R737	NRSA63J-0R0X	MG RESISTOR	0Ω 1/16W J						
R738	NRSA63J-472X	MG RESISTOR	4.7kΩ 1/16W J		CN501	QGB2027M4-22S	CONNECTOR	B-B (1-22)	
R739	NRSA63J-472X	MG RESISTOR	4.7kΩ 1/16W J		CN701	QNZ0605-001	CAR CONNECTOR		
R740	NRSA63J-472X	MG RESISTOR	4.7kΩ 1/16W J						
R741	NRSA63J-103X	MG RESISTOR	10kΩ 1/16W J		CN702	QGA2006F1-02	CONNECTOR	W-B (1-2)	G501 E,G50 1EX
R742	NRSA63J-103X	MG RESISTOR	10kΩ 1/16W J						
R743	NRSA63J-103X	MG RESISTOR	10kΩ 1/16W J		CN901	QNZ0650-001	CAR CONNECTOR		
R744	NRSA63J-103X	MG RESISTOR	10kΩ 1/16W J		J1	QNB0100-002	CAR ANT JACK		
R745	NRSA63J-103X	MG RESISTOR	10kΩ 1/16W J		J321	QNN0489-001	PIN JACK		
R746	NRSA63J-103X	MG RESISTOR	10kΩ 1/16W J		J801	QNZ0095-001	CONNECTOR		
R747	NRSA63J-472X	MG RESISTOR	4.7kΩ 1/16W J						
R748	NRSA63J-472X	MG RESISTOR	4.7kΩ 1/16W J		PP1	QZW0010-001	STYLE PIN		G501 E,G50 1EX
R749	NRSA63J-472X	MG RESISTOR	4.7kΩ 1/16W J						
R750	NRSA63J-103X	MG RESISTOR	10kΩ 1/16W J		S701	QSW0451-001	DETECT SW		
R751	NRSA63J-103X	MG RESISTOR	10kΩ 1/16W J		S702	QSW0451-001	DETECT SW		
R752	NRSA63J-473X	MG RESISTOR	47kΩ 1/16W J		S703	QSW1049-001Z	TACT SW		
R753	NRSA63J-473X	MG RESISTOR	47kΩ 1/16W J						
R754	NRSA63J-821X	MG RESISTOR	820Ω 1/16W J		TU1	QAU0313-001	TUNER		G501 E,G50 1EX
R755	NRSA63J-106X	MG RESISTOR	10MΩ 1/16W J						G507 EE
R756	NRSA63J-473X	MG RESISTOR	47kΩ 1/16W J		TU1	QAU0314-001	TUNER		
R757	NRSA63J-222X	MG RESISTOR	2.2kΩ 1/16W J		X31	QAX0616-001Z	CRYSTAL	10.250MHz	
R758	NRSA63J-473X	MG RESISTOR	47kΩ 1/16W J						
R760	NRSA63J-473X	MG RESISTOR	47kΩ 1/16W J		X71	QAX0263-001Z	CRYSTAL	4.332MHz	G501 E,G50 1EX
					X401	QAX0760-001Z	CRYSTAL		
R761	NRSA63J-473X	MG RESISTOR	47kΩ 1/16W J	G501 E,G50 1EX	X701	QAX0617-001Z	CRYSTAL	12.500MHz	
R763	NRSA63J-102X	MG RESISTOR	1kΩ 1/16W J		X702	QAX0401-001	CRYSTAL	32.768KHz	
R764	NRSA63J-101X	MG RESISTOR	100Ω 1/16W J						
R766	NRSA63J-222X	MG RESISTOR	2.2kΩ 1/16W J	G501 E,G50 1EX					

# Front board

Block No. [0][2][0][0]

△ Symbol No.	Part No.	Part Name	Description	Local
IC601	LC75823W	IC		
IC602	RPM7338-V4	RM.RECEIVER		
Q640	2SB624/4/-X	TRANSISTOR		
Q641	UN2211-X	TRANSISTOR		
D601	SML-310VT/JK/-X	LED		G501 E,G50 1EX
D601	LNJ308G81/1-3/X	LED		G507 EE
D602	SML-310VT/JK/-X	LED		G501 E,G50 1EX
D602	LNJ308G81/1-3/X	LED		G507 EE
D603	SML-310VT/JK/-X	LED		G501 E,G50 1EX
D603	LNJ308G81/1-3/X	LED		G507 EE
D604	SML-310VT/JK/-X	LED		G501 E,G50 1EX
D604	LNJ308G81/1-3/X	LED		G507 EE
D605	SML-310VT/JK/-X	LED		G501 E,G50 1EX
D605	LNJ308G81/1-3/X	LED		G507 EE
D606	SML-310VT/JK/-X	LED		G501 E,G50 1EX
D606	LNJ308G81/1-3/X	LED		G507 EE
D607	SML-310VT/JK/-X	LED		G501 E,G50 1EX
D607	LNJ308G81/1-3/X	LED		G507 EE
D608	SML-310VT/JK/-X	LED		G501 E,G50 1EX
D608	LNJ308G81/1-3/X	LED		G507 EE
D609	SML-310VT/JK/-X	LED		G501 E,G50 1EX
D609	LNJ308G81/1-3/X	LED		G507 EE
D610	SML-310VT/JK/-X	LED		G501 E,G50 1EX
D610	LNJ308G81/1-3/X	LED		G507 EE
D611	SML-310VT/JK/-X	LED		G501 E,G50 1EX
D611	LNJ308G81/1-3/X	LED		G507 EE
D612	SML-310VT/JK/-X	LED		G501 E,G50 1EX
D612	LNJ308G81/1-3/X	LED		G507 EE
D613	SML-310VT/JK/-X	LED		G501 E,G50 1EX
D613	LNJ308G81/1-3/X	LED		G507 EE
D614	SML-310VT/JK/-X	LED		G501 E,G50 1EX
D614	LNJ308G81/1-3/X	LED		G507 EE
D615	SML-310VT/JK/-X	LED		G501 E,G50 1EX

△ Symbol No.	Part No.	Part Name	Description	Local
D615	LNJ308G81/1-3/X	LED		G507 EE
D616	SML-310VT/JK/-X	LED		G501 E,G50 1EX
D616	LNJ308G81/1-3/X	LED		G507 EE
D617	SML-310VT/JK/-X	LED		G501 E,G50 1EX
D617	LNJ308G81/1-3/X	LED		G507 EE
D618	SML-310VT/JK/-X	LED		G501 E,G50 1EX
D618	LNJ308G81/1-3/X	LED		G507 EE
D619	SML-310VT/JK/-X	LED		G501 E,G50 1EX
D619	LNJ308G81/1-3/X	LED		G507 EE
D620	SML-310VT/JK/-X	LED		G501 E,G50 1EX
D620	LNJ308G81/1-3/X	LED		G507 EE
D621	SML-310VT/JK/-X	LED		G501 E,G50 1EX
D621	LNJ308G81/1-3/X	LED		G507 EE
D631	SML-310LT/MN/-X	LED		
D641	UDZS5.1B-X	Z DIODE		
D642	MA111-X	SI DIODE		
D643	MA8062/M/-X	Z DIODE		
D645	NSPW310BS/BRS/	LED		
D646	NSPW310BS/BRS/	LED		
C601	NCB31HK-223X	C CAPACITOR	0.022uF 50V K	
C602	NCS31HJ-681X	C CAPACITOR	680pF 50V J	
C603	NBE20JM-106X	TA E CAPACITOR	10uF 6.3V M	
C611	NCB31HK-123X	C CAPACITOR	0.012uF 50V K	
C612	NBE20JM-475X	TA E CAPACITOR	4.7uF 6.3V M	
R601	NRSA63J-821X	MG RESISTOR	820Ω 1/16W J	
R602	NRSA63J-821X	MG RESISTOR	820Ω 1/16W J	
R603	NRSA63J-122X	MG RESISTOR	1.2kΩ 1/16W J	
R604	NRSA63J-182X	MG RESISTOR	1.8kΩ 1/16W J	
R605	NRSA63J-272X	MG RESISTOR	2.7kΩ 1/16W J	
R606	NRSA63J-392X	MG RESISTOR	3.9kΩ 1/16W J	
R607	NRSA63J-821X	MG RESISTOR	820Ω 1/16W J	
R608	NRSA63J-821X	MG RESISTOR	820Ω 1/16W J	
R609	NRSA63J-122X	MG RESISTOR	1.2kΩ 1/16W J	
R610	NRSA63J-182X	MG RESISTOR	1.8kΩ 1/16W J	
R611	NRSA63J-272X	MG RESISTOR	2.7kΩ 1/16W J	
R612	NRSA63J-392X	MG RESISTOR	3.9kΩ 1/16W J	
R613	NRSA63J-821X	MG RESISTOR	820Ω 1/16W J	
R614	NRSA63J-821X	MG RESISTOR	820Ω 1/16W J	
R631	NRS181J-821X	MG RESISTOR	820Ω 1/8W J	
R632	NRSA02J-271X	MG RESISTOR	270Ω 1/10W J	
R634	NRSA02J-271X	MG RESISTOR	270Ω 1/10W J	
R636	NRSA02J-821X	MG RESISTOR	820Ω 1/10W J	
R638	NRSA02J-271X	MG RESISTOR	270Ω 1/10W J	
R640	NRSA02J-271X	MG RESISTOR	270Ω 1/10W J	
R642	NRSA02J-471X	MG RESISTOR	470Ω 1/10W J	
R644	NRSA02J-122X	MG RESISTOR	1.2kΩ 1/10W J	
R645	NRSA02J-122X	MG RESISTOR	1.2kΩ 1/10W J	
R646	NRSA02J-271X	MG RESISTOR	270Ω 1/10W J	
R648	NRSA02J-122X	MG RESISTOR	1.2kΩ 1/10W J	
R649	NRSA02J-122X	MG RESISTOR	1.2kΩ 1/10W J	
R651	NRSA63J-222X	MG RESISTOR	2.2kΩ 1/16W J	
R652	NRSA63J-222X	MG RESISTOR	2.2kΩ 1/16W J	
R653	NRSA63J-103X	MG RESISTOR	10kΩ 1/16W J	
R654	NRSA63J-103X	MG RESISTOR	10kΩ 1/16W J	
R655	NRSA63J-103X	MG RESISTOR	10kΩ 1/16W J	
R656	NRSA63J-103X	MG RESISTOR	10kΩ 1/16W J	
R657	NRSA63J-513X	MG RESISTOR	51kΩ 1/16W J	
R658	NRSA63J-184X	MG RESISTOR	180kΩ 1/16W J	
R660	NRS181J-391X	MG RESISTOR	390Ω 1/8W J	

Symbol No.	Part No.	Part Name	Description	Local
R661	NRS181J-391X	MG RESISTOR	390Ω 1/8W J	
R670	NRSA63J-0R0X	MG RESISTOR	0Ω 1/16W J	
R672	NRS181J-471X	MG RESISTOR	470Ω 1/8W J	
R673	NRS181J-473X	MG RESISTOR	47kΩ 1/8W J	
R674	NRS181J-102X	MG RESISTOR	1kΩ 1/8W J	
R681	NRSA63J-101X	MG RESISTOR	100Ω 1/16W J	
R691	NRSA63J-103X	MG RESISTOR	10kΩ 1/16W J	
R692	NRSA63J-471X	MG RESISTOR	470Ω 1/16W J	
CN601	NNZ0087-001	CAR CONNECTOR		
EN601	QSW0863-003	JOG SHUTTLE SW		
S601	NSW0206-001X	TACT SWITCH		
S602	NSW0206-001X	TACT SWITCH		
S603	NSW0206-001X	TACT SWITCH		
S604	NSW0206-001X	TACT SWITCH		
S605	NSW0206-001X	TACT SWITCH		
S606	NSW0206-001X	TACT SWITCH		
S607	NSW0206-001X	TACT SWITCH		
S608	NSW0206-001X	TACT SWITCH		
S609	NSW0206-001X	TACT SWITCH		
S610	NSW0206-001X	TACT SWITCH		
S611	NSW0206-001X	TACT SWITCH		
S612	NSW0206-001X	TACT SWITCH		
S613	NSW0206-001X	TACT SWITCH		
S614	NSW0206-001X	TACT SWITCH		
S615	NSW0206-001X	TACT SWITCH		
S616	NSW0206-001X	TACT SWITCH		
S617	NSW0206-001X	TACT SWITCH		

**<MEMO>**

# Packing materials and accessories parts list

Block No. **M 3 M M**

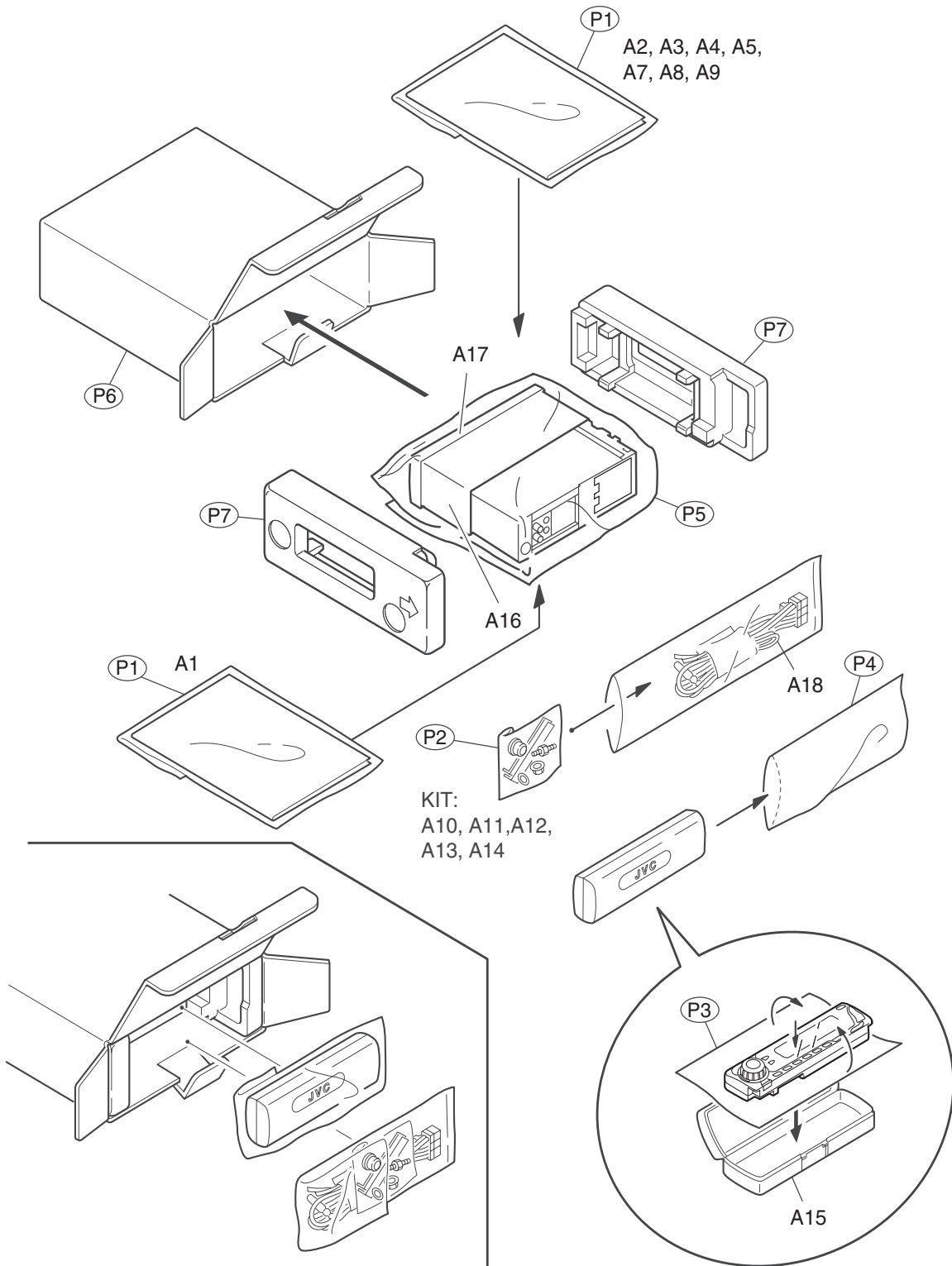



# Packing and Accessories

Block No. [M][3][M][M]

△ Symbol No.	Part No.	Part Name	Description	Local
A 1	GET0193-001A	INST BOOK	ENG GER FRE DUT	G501 E,G50 1EX
A 1	GET0194-001A	INST BOOK	ENG RUS	G507 EE
A 2	GET0193-002A	INST BOOK	SPA ITA POL RUS	G501 E
A 2	GET0193-003A	INST BOOK	SWE DAN FIN GRE	G501 EX
A 3	GET0193-005A	INSTALL MANUAL	ENG GER FRE DUT	G501 E,G50 1EX
A 3	GET0194-002A	INSTALL MANUAL	ENG RUS	G507 EE
A 4	GET0193-006A	INSTALL MANUAL	SPA ITA POL RUS	G501 E
A 4	GET0193-007A	INSTALL MANUAL	SWE DAN FIN GRE	G501 EX
A 5	GET0208-002A	DEMO MODE SHT		G501 EX
A 5	GET0208-001A	DEMO MODE SHT		G501 E,G50 7EE
A 6	LVT1120-002A	MP3 GUIDE		G501 E,G50 1EX
A 6	LVT1120-004A	MP3 GUIDE		G507 EE
A 7	BT-54013-7	WARRANTY CARD		
A 8	VND3050-002	IDENTITY CARD		G501 E,G50 1EX
A 9	VND3046-001	SERIAL TICKET		
A 10	VKZ4027-202	PLUG NUT		
A 11	VKH4871-001SS	MOUNT BOLT		
A 12	VKZ4328-001	LOCK NUT		
A 13	WNS5000Z	WASHER		
A 14	GE40130-002A	HOOK	(x2)	
A 15	FSJB3002-00C	HARD CASE		
A 16	GE20137-003A	MOUNTING SLEEVE		
A 17	GE20149-007A	TRIM PLATE		
A 18	QAM0176-002	POWER CORD		
KIT	KSFX480K-SCREW1	SCREW PARTS KIT	A10 A11 A12 A13 A14	
P 1	FSPG4002-001	POLY BAG	(x2)	G501 E,G50 1EX
P 1	FSPG4002-001	POLY BAG		G507 EE
P 2	QPA00801205	POLY BAG	8cm x 12cm	
P 3	FSYH4036-068	SHEET		
P 4	QPA01003003	POLY BAG	10cm x 30cm	
P 5	QPC03004315P	POLY BAG	30cm x 43cm	
P 6	GE31134-002A	CARTON		G501 E,G50 1EX
P 6	GE31287-001A	CARTON		G507 EE
P 7	GE10070-002A	EPS CUSHION		

## Free Manuals Download Website

<http://myh66.com>

<http://usermanuals.us>

<http://www.somanuals.com>

<http://www.4manuals.cc>

<http://www.manual-lib.com>

<http://www.404manual.com>

<http://www.luxmanual.com>

<http://aubethermostatmanual.com>

Golf course search by state

<http://golfingnear.com>

Email search by domain

<http://emailbydomain.com>

Auto manuals search

<http://auto.somanuals.com>

TV manuals search

<http://tv.somanuals.com>