

JVC

SERVICE MANUAL

CD RECEIVER

**KD-R400J, KD-R401E, KD-R401EX,
KD-R401EY, KD-R401EU, KD-R402EY,
KD-R407EE, KD-R501E, KD-R501EX,
KD-R501EY, KD-R501EU, KD-R504UI,
KD-R505U, KD-R505UN, KD-R505UT,
KD-R505UH, KD-R506U, KD-R506UN,
KD-R506UT, KD-R506UH, KD-R508UF**

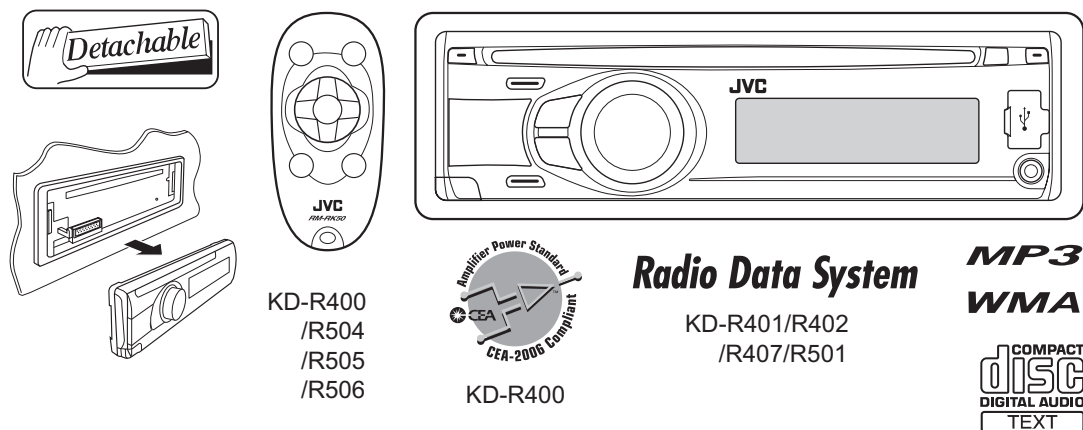

Lead free solder used in the board (material : Sn-Ag-Cu, melting point : 219 Centigrade)
Lead free solder used in the board (material : Sn-Cu, melting point : 230 Centigrade)

TABLE OF CONTENTS

1	PRECAUTION.....	1-5
2	SPECIFIC SERVICE INSTRUCTIONS.....	1-8
3	DISASSEMBLY	1-8
4	ADJUSTMENT	1-17
5	TROUBLESHOOTING	1-21

SPECIFICATION

KD-R400J

AUDIO AMPLIFIER SECTION			
Power Output	20 W RMS × 4 Channels at 4 Ω and < or = 1%THD+N	Amplifier Power Standard	
Signal-to-Noise Ratio	80 dBA (reference 1 W into 4 Ω)		
Load Impedance	4 Ω (4 Ω to 8 Ω allowance)		
Tone Control Range	Bass	±12 dB (60 Hz 80 Hz 100 Hz 200 Hz) Q1.0 Q1.25 Q1.5 Q2.0	
	Middle	±12 dB (0.5 kHz 1.0 kHz 1.5 kHz 2.5 kHz) Q0.75 Q1.0 Q1.25	
	Treble	±12 dB (10.0 kHz 12.5 kHz 15.0 kHz 17.5 kHz) Q = Fixed	
Frequency Response	40 Hz to 20 000 Hz		
Line-Out Level/Impedance	2.5 V/20 kΩ load (full scale)		
Subwoofer-Out Level/Impedance	2.5 V/20 kΩ load (full scale)		
Output Impedance	1 kΩ		
Other Terminal	USB input jack AUX (auxiliary) input jack Steering wheel remote input		
TUNER SECTION			
Frequency Range	FM	with channel interval set to 100 kHz or 200 kHz	87.5 MHz to 107.9 MHz
		with channel interval set to 50 kHz	87.5 MHz to 108.0 MHz
	AM	with channel interval set to 10 kHz	530 kHz to 1 710 kHz
		with channel interval set to 9 kHz	531 kHz to 1 602 kHz
FM Tuner	Usable Sensitivity		11.3 dBf (1.0 μV/75 Ω)
	50 dB Quieting Sensitivity		16.3 dBf (1.8 μV/75 Ω)
	Alternate Channel Selectivity (400 kHz)		65 dB
	Frequency Response		40 Hz to 15 000 Hz
	Stereo Separation		35 dB
AM Tuner	Sensitivity		20 μV
	Selectivity		35 dB
CD PLAYER SECTION			
Type	Compact disc player		
Signal Detection System	Non-contact optical pickup (semiconductor laser)		
Number of Channels	2 channels (stereo)		
Frequency Response	5 Hz to 20 000 Hz		
Dynamic Range	96 dB		
Signal-to-Noise Ratio	98 dB		
Wow and Flutter	Less than measurable limit		
MP3 Decoding Format (MPEG1/2 Audio Layer 3)	Max. Bit Rate 320 kbps		
WMA (Windows Media® Audio) Decoding Format	Max. Bit Rate 320 kbps		
USB SECTION			
USB Standard	USB 1.1, USB 2.0		
Data Transfer Rate (Full Speed)	Max. 12 Mbps		
Compatible Device	Mass storage class		
Compatible File System	FAT 32/16/12		
Playable Audio Format	MP3/WMA		
Max. Current	DC 5 V 500 mA		
GENERAL			
Power Requirement	Operating Voltage	DC 14.4 V (11 V to 16 V allowance)	
Grounding System		Negative ground	
Allowable Operating Temperature		0 °C to +40 °C (32 °F to 104 °F)	
Dimensions (W × H × D) (approx.)	Installation Size	182 mm × 52 mm × 160 mm (7-3/16" × 2-1/16" × 6-5/16")	
	Panel Size	188 mm × 58 mm × 6 mm (7-7/16" × 2-5/16" × 1/4")	
Mass	1.3 kg (2.9 lbs) (excluding accessories)		

Design and specifications are subject to change without notice.

KD-R401E/EX/EY/EU KD-R402EY KD-R407EE KD-R501E/EX/EY/EU

AUDIO AMPLIFIER SECTION			
Maximum Power Output	Front/Rear	50 W per channel	
Continuous Power Output (RMS)	Front/Rear	19 W per channel into 4 Ω 40 Hz to 20 000 Hz at no more than 0.8% total harmonic distortion.	
Load Impedance		4 Ω (4 Ω bis 8 Ω Toleranz)	
Tone Control Range	Bass	±12 dB (60 Hz 80 Hz 100 Hz 200 Hz) Q1.0 Q1.25 Q1.5 Q2.0	
	Middle	±12 dB (0.5 kHz 1.0 kHz 1.5 kHz 2.5 kHz) Q0.75 Q1.0 Q1.25	
	Treble	±12 dB (10.0 kHz 12.5 kHz 15.0 kHz 17.5 kHz) Q = Fixed	
Frequency Response		40 Hz to 20 000 Hz	
Signal-to-Noise Ratio		70 dB	
Line-Out Level/Impedance		2.5 V/20 kΩ load (full scale)	
Output Impedance		1 kΩ	
Subwoofer-Out Level/Impedance		2.5 V/20 kΩ load (full scale)	
Other Terminal		USB input jack, AUX (auxiliary) input jack	
TUNER SECTION			
Frequency Range	FM	87.5 MHz to 108.0 MHz	
	(KD-R407)	FM-LO 65.00 MHz to 74.00 MHz	
	AM	MW	522 kHz to 1 620 kHz
		LW	144 kHz to 279 kHz
FM Tuner	Usable Sensitivity	11.3 dBf (1.0 μV/75 Ω)	
	50 dB Quieting Sensitivity	16.3 dBf (1.8 μV/75 Ω)	
	Alternate Channel Selectivity (400 kHz)	65 dB	
	Frequency Response	40 Hz to 15 000 Hz	
	Stereo Separation	30 dB	
MW Tuner	Sensitivity	20 μV	
	Selectivity	35 dB	
LW Tuner	Sensitivity	50 μV	
CD PLAYER SECTION			
Type		Compact disc player	
Signal Detection System		Non-contact optical pickup (semiconductor laser)	
Number of Channels		2 channels (stereo)	
Frequency Response		5 Hz to 20 000 Hz	
Dynamic Range		93 dB	
		(KD-R407) : 96 dB	
Signal-to-Noise Ratio		98 dB	
Wow and Flutter		Less than measurable limit	
MP3 Decoding Format (MPEG1/2 Audio Layer 3)		Max. Bit Rate 320 kbps	
WMA (Windows Media® Audio) Decoding Format		Max. Bit Rate 320 kbps	
USB SECTION			
USB Standard		USB 1.1, USB 2.0	
Data Transfer Rate (Full Speed)		Max. 12 Mbps	
Compatible Device		Mass storage class	
Compatible File System		FAT 32/16/12	
Playable Audio Format		MP3/WMA	
Max. Current		DC 5 V 500 mA	
GENERAL			
Power Requirement	Operating Voltage	DC 14.4 V (11 V to 16 V allowance)	
Grounding System		Negative ground	
Allowable Operating Temperature		0 °C to +40 °C	
Dimensions (W × H × D) (approx.)	Installation Size	182 mm × 52 mm × 160 mm	
	Panel Size	188 mm × 58 mm × 12 mm	
Mass		1.3 kg (excluding accessories)	

Design and specifications are subject to change without notice.

KD-R504UI KD-R505U/UN/UT KD-R506U/UN/UT KD-R508UF

AUDIO AMPLIFIER SECTION		
Maximum Power Output	Front/Rear	50 W per channel
Continuous Power Output (RMS)	Front/Rear	19 W per channel into 4 Ω 40 Hz to 20 000 Hz at no more than 0.8% total harmonic distortion.
Load Impedance		4 Ω (4 Ω to 8 Ω allowance)
Tone Control Range	Bass	± 12 dB (60 Hz 80 Hz 100 Hz 200 Hz) Q1.0 Q1.25 Q1.5 Q2.0
	Middle	± 12 dB (0.5 kHz 1.0 kHz 1.5 kHz 2.5 kHz) Q0.75 Q1.0 Q1.25
	Treble	± 12 dB (10.0 kHz 12.5 kHz 15.0 kHz 17.5 kHz) Q = Fixed
Frequency Response		40 Hz to 20 000 Hz
Signal-to-Noise Ratio		70 dB
Line-Out Level/Impedance		2.5 V/20 k Ω load (full scale)
Output Impedance		1 k Ω
Subwoofer-Out Level/Impedance		2.5 V/20 k Ω load (full scale)
Other Terminal		USB input jack, AUX (auxiliary) input jack
TUNER SECTION		
Frequency Range	FM	87.5 MHz to 108.0 MHz
	AM	531 kHz to 1 602 kHz
FM Tuner	Usable Sensitivity	11.3 dBf (1.0 μ V/75 Ω)
	50 dB Quieting Sensitivity	16.3 dBf (1.8 μ V/75 Ω)
	Alternate Channel Selectivity (400 kHz)	65 dB
	Frequency Response	40 Hz to 15 000 Hz
	Stereo Separation	30 dB
AM Tuner	Sensitivity	20 μ V
	Selectivity	35 dB
CD PLAYER SECTION		
Type		Compact disc player
Signal Detection System		Non-contact optical pickup (semiconductor laser)
Number of Channels		2 channels (stereo)
Frequency Response		5 Hz to 20 000 Hz
Dynamic Range		96 dB
Signal-to-Noise Ratio		98 dB
Wow and Flutter		Less than measurable limit
MP3 Decoding Format (MPEG1/2 Audio Layer 3)		Max. Bit Rate 320 kbps
WMA (Windows Media [®] Audio) Decoding Format		Max. Bit Rate 320 kbps
USB SECTION		
USB Standard		USB 1.1, USB 2.0
Data Transfer Rate (Full Speed)		Max. 12 Mbps
Compatible Device		Mass storage class
Compatible File System		FAT 32/16/12
Playable Audio Format		MP3/WMA
Max. Current		DC 5 V 500 mA
GENERAL		
Power Requirement	Operating Voltage	DC 14.4 V (11 V to 16 V allowance)
Grounding System		Negative ground
Allowable Operating Temperature		0 $^{\circ}$ C to +40 $^{\circ}$ C
Dimensions (W \times H \times D) (approx.)	Installation Size	182 mm \times 52 mm \times 160 mm
	Panel Size	188 mm \times 58 mm \times 6 mm
Mass		1.3 kg (excluding accessories)

Design and specifications are subject to change without notice.

SECTION 1 PRECAUTION

1.1 Safety Precautions

 **CAUTION** Burrs formed during molding may be left over on some parts of the chassis. Therefore, pay attention to such burrs in the case of performing repair of this system.

 **CAUTION** Please use enough caution not to see the beam directly or touch it in case of an adjustment or operation check.

1.2 Preventing static electricity

Electrostatic discharge (ESD), which occurs when static electricity stored in the body, fabric, etc. is discharged, can destroy the laser diode in the traverse unit (optical pickup). Take care to prevent this when performing repairs.

1.2.1 Grounding to prevent damage by static electricity

Static electricity in the work area can destroy the optical pickup (laser diode) in devices such as laser products.

Be careful to use proper grounding in the area where repairs are being performed.

(1) Ground the workbench

Ground the workbench by laying conductive material (such as a conductive sheet) or an iron plate over it before placing the traverse unit (optical pickup) on it.

(2) Ground yourself

Use an anti-static wrist strap to release any static electricity built up in your body.

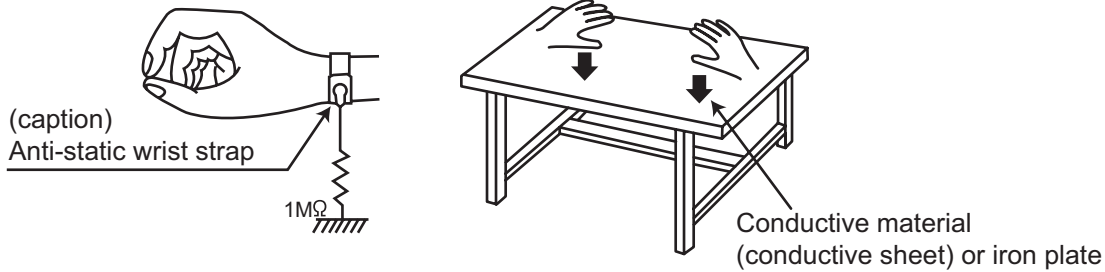

(3) Handling the optical pickup

- In order to maintain quality during transport and before installation, both sides of the laser diode on the replacement optical pickup are shorted. After replacement, return the shorted parts to their original condition. (Refer to the text.)
- Do not use a tester to check the condition of the laser diode in the optical pickup. The tester's internal power source can easily destroy the laser diode.

1.3 Handling the traverse unit (optical pickup)

- (1) Do not subject the traverse unit (optical pickup) to strong shocks, as it is a sensitive, complex unit.
- (2) Cut off the shorted part of the flexible cable using nippers, etc. after replacing the optical pickup. For specific details, refer to the replacement procedure in the text. Remove the anti-static pin when replacing the traverse unit. Be careful not to take too long a time when attaching it to the connector.
- (3) Handle the flexible cable carefully as it may break when subjected to strong force.
- (4) It is not possible to adjust the semi-fixed resistor that adjusts the laser power. Do not turn it.

1.4 Attention when traverse unit is decomposed

***Please refer to "Disassembly method" in the text for the pickup unit.**

- Apply solder to the short land before the card wire is disconnected from the connector on the pickup unit. (If the card wire is disconnected without applying solder, the pickup may be destroyed by static electricity.)
- In the assembly, be sure to remove solder from the short land after connecting the card wire.

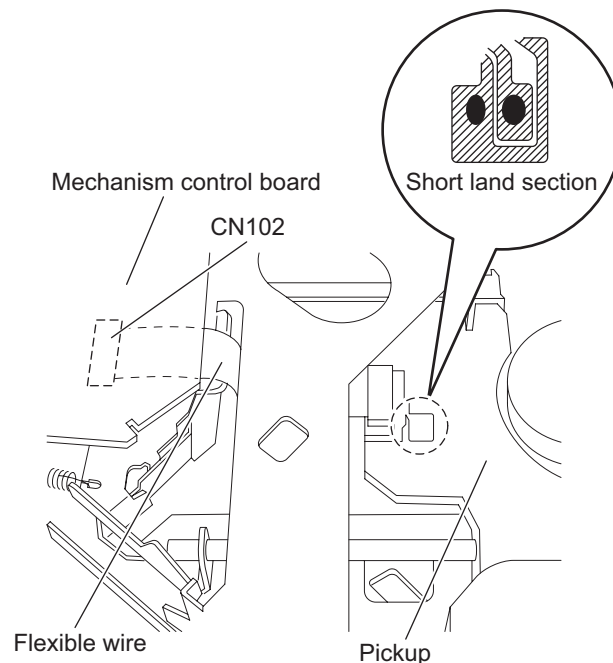

1.5 Important for laser products

1.CLASS 1 LASER PRODUCT

2.CAUTION :

(For U.S.A.) Visible and/or invisible class II laser radiation when open. Do not stare into beam.

(Others) Visible and/or invisible class 1M laser radiation when open. Do not view directly with optical instruments.

3.CAUTION : Visible and/or invisible laser radiation when open and inter lock failed or defeated. Avoid direct exposure to beam.

4.CAUTION : This laser product uses visible and/or invisible laser radiation and is equipped with safety switches which prevent emission of radiation when the drawer is open and the safety interlocks have failed or are defeated. It is dangerous to defeat the safety switches.

(For U.S.A.)

CAUTION : Visible and/or invisible class II laser radiation when open. Do not stare into beam.

(Others)

CAUTION : Visible and/or invisible class 1M laser radiation when open. Do not view directly with optical instruments

ACHTUNG: Sichtbare und/oder unsichtbare Laserstrahlung der Klasse 1M bei offenen Abdeckungen. Nicht direkt mit optischen Instrumenten betrachten.

ATTENTION: Rayonnement laser visible et/ou invisible de classe 1M une fois ouvert. Ne pas regarder directement avec des instruments optiques.

VOORZICHTIG: Zichtbare en/of onzichtbare klasse 1M laserstralen indien geopend. Bekijk niet direct met optische instrumenten.

ATTENZIONE: Radiazione laser in classe 1M visibile e/o invisibile quando aperto. Non osservare direttamente con strumenti ottici.

WARNING: Synlig och/eller osynlig laserstrålning, klass 1M, när denna del är öppnad. Betrakta ej strålen med optiska instrument.

VARO! Avattaessa olet alttiina näkyvälle ja/tai näkymättömälle luokan 1M lasersäteilylle. Älä tarkastele sitä optisen laitteen läpi.

ADVARSEL: Synlig og/eller usynlig klasse 1M-laserstrålning ved åbning. Se ikke direkte med optiske instrumenter.

AVISO: Radiación láser de clase 1M visible y/o invisible cuando está abierto. No mirar directamente con instrumental óptico.

PRECAUÇÃO: Radiação laser de classe 1M visível e/ou invisível quando aberto. Não olhe diretamente com instrumentos ópticos.

5.CAUTION : If safety switches malfunction, the laser is able to function.

6.CAUTION : Use of controls, adjustments or performance of procedures other than those specified here in may result in hazardous radiation exposure.



CAUTION Please use enough caution not to see the beam directly or touch it in case of an adjustment or operation check.

PRECAUÇÃO: Radiação laser de classe 1M visível e/ou invisível quando aberto. Não olhe diretamente com instrumentos ópticos.

ПРЕДУПРЕЖДЕНИЕ: В открытом состоянии происходит видимое и/или невидимое излучение лазера класса 1M. Не смотрите непосредственно в оптические инструменты.

UWAGA: Otwarcie spowoduje narażenie na widzialne i/lub niewidzialne promieniowanie lasera klasy 1M. Nie patrzeć bezpośrednio w przyrządy optyczne.

UPOZORNĚNÍ: Při otevření vydává viditelné popř. neviditelné laserové ozáření třídy 1M. Nedívejte se do otvoru přímo s optickými nástroji.

FIGYELMEZTETÉS: Látható és/vagy láthatatlan 1M osztályú sugárzás nyitott állapotban. Ne nézze közvetlenül optikai műszerekkel.

注意 : 打開蓋板可能會產生可見或不可見的 1M 級鐳射。不要使用光學儀器直接進行窺視。

注意 : 打开盖板可能会产生可见或不可见的 1M 级辐射。不要使用光学仪器直接进行窥视。

تنبيه: يوجد إشعاع ليزري مرئي و/أو غير مرئي من الفئة 1M عندما يكون الجهاز مفتوحاً. تجنب النظر مباشرة داخل الجهاز باستخدام أدوات بصرية.

احتياطات: هنگامی که باز گردد، تشعشع مرئی و یا نامرئی کلاس 1M لیزر وجود دارد. با لوازم چشمی مستقیماً به آن نگاه نکنید.

주의: 개방하면 가지 및/또는 비가시 클래스 1M 레이저 방사선이 나옵니다. 광학 기구로 직접 들여다보지 마십시오.

REPRODUCTION AND POSITION OF LABELS and PRINT WARNING LABEL and PRINT



CAUTION VISIBLE AND/OR INVISIBLE CLASS 1M LASER RADIATION WHEN OPEN. DO NOT VIEW DIRECTLY WITH OPTICAL INSTRUMENTS. IEC00825-1:2001 (ENG)	ATTENTION RAYONNEMENT LASER VISIBLE ET/OU INVISIBLE DE CLASSE 1M UNE FOIS OUVERT. NE PAS REGARDER DIRECTEMENT AVEC DES INSTRUMENTS OPTIQUES. (FRA)	AVISO RADIACION LASER DE CLASE 1M VISIBLE Y/O INVISIBLE CUANDO ESTA ABIERTO. NO MIRAR DIRECTAMENTE CON INSTRUMENTAL OPTICO. (ESP)	WARNING SYNLIG OCH/ELLER OSYNLIG LASERSTRÅLNING, KLASS 1M, NÄR DENNA DEL ÄR ÖPPNAD. BETRAKTA EJ STRÅLEN MED OPTISKA INSTRUMENT. (SWE)	注意 ここを覗くと有害な 及び/または不可視 のクラス 1M レーザー放射が 出ます。 光学機器で直接 見ないでください。 (JPN)	CAUTION VISIBLE AND/OR INVISIBLE CLASS II LASER RADIATION WHEN OPEN. DO NOT STARE INTO BEAM. FDA 21 CFR (ENG) LV44803-003A
--	--	---	---	--	---

SECTION 2 SPECIFIC SERVICE INSTRUCTIONS

This service manual does not describe SPECIFIC SERVICE INSTRUCTIONS.

SECTION 3 DISASSEMBLY

3.1 Main body (Used figure are KD-R400J)

3.1.1 Removing the bottom chassis (See Fig.1, 2)

- (1) Remove the three screws **A** attaching the Heat sink. (See Fig.1)
- (2) Remove the two screws **B** and one screw **C** attaching the Bottom chassis. (See Fig.2)
- (3) Slide to backward and then remove the Bottom chassis.

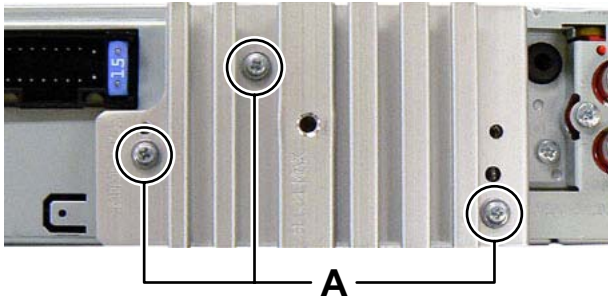

Fig.1

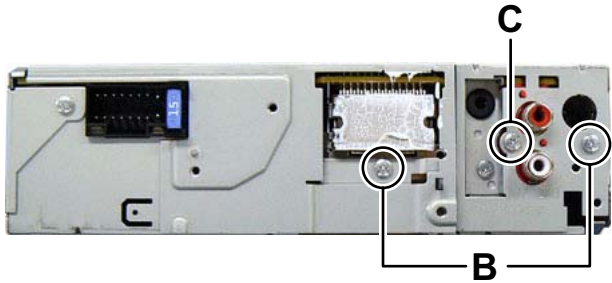

Fig.2

3.1.2 Removing the Front chassis (See Fig.3)

- (1) Disengage four hooks **a** engaged both side of the Front chassis.

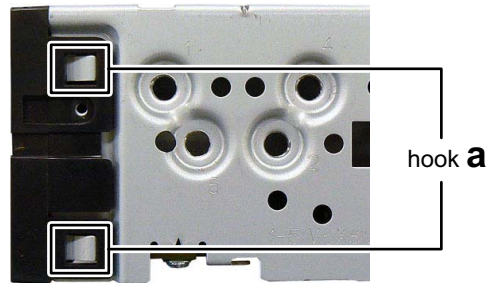

Fig.3

3.1.3 Removing the Main board (See Fig.4 to 6)

- (1) Remove the two screws **D** and one screw **E** attaching the Side panel. (See Fig.4)
- (2) Remove the one screw **F** attaching the bracket. (See Fig.5)
- (3) Remove the three screws **G** attaching the main board and then disconnect the board to board connector **CN501** connected to CD mechanism. (See Fig.6)

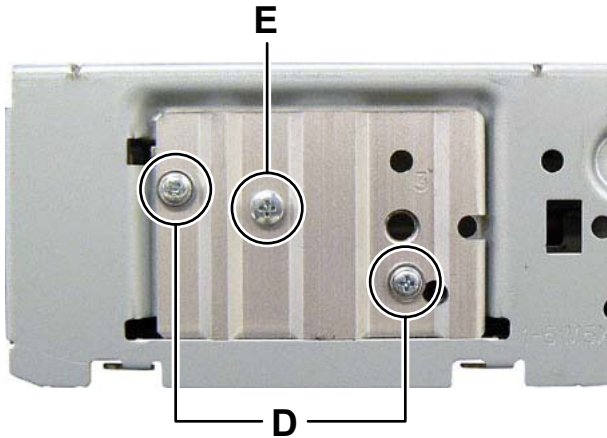

Fig.4

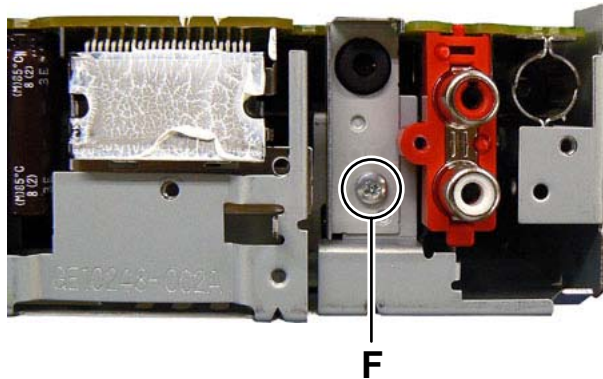

Fig.5

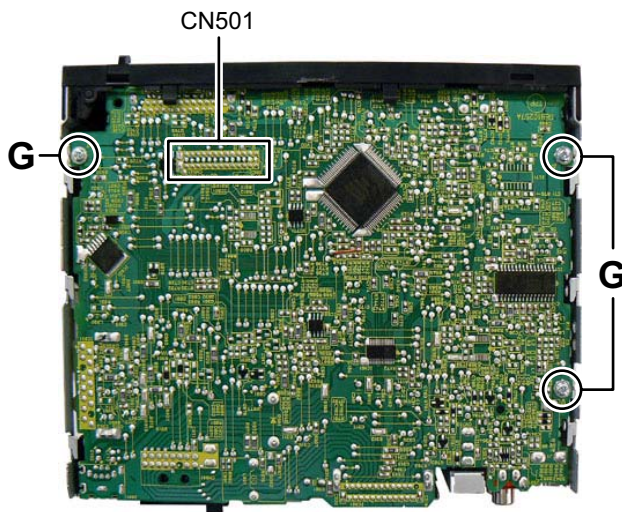

Fig.6

3.1.4 Removing the CD mechanism (See Fig.7)

- (1) Remove the three screws **H** attaching the CD mechanism.

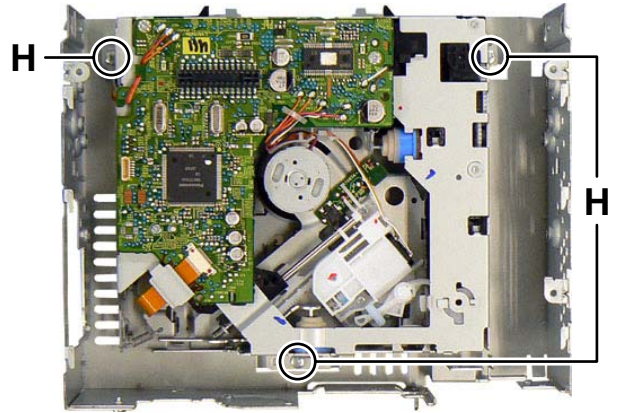

Fig.7

3.1.5 Removing the Switch board (See Fig.8)

- (1) Remove the Volume knob.
- (2) Remove the four screws **J** attaching the Rear cover.
- (3) Disengage eleven hooks **b** engaged Rear cover.

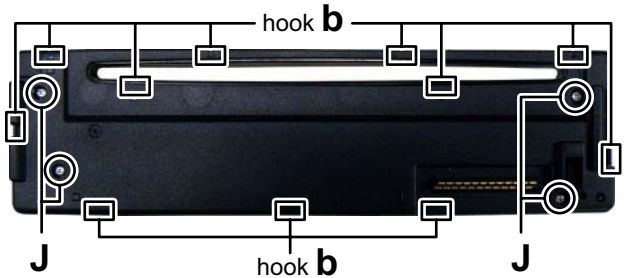

Fig.8

3.2 CD MECHANISM assembly section

- Remove the CD MECHANISM assembly from the main body.

3.2.1 Removing the MECHANISM CONTROL BOARD assembly (See Fig.1 and 2)

- (1) From the bottom side of CD MECHANISM assembly, remove the solders from the soldered sections (a, b and c) on the MECHANISM CONTROL BOARD assembly. (See Fig.1.)
- (2) Remove the three screws **A** attaching the MECHANISM CONTROL BOARD assembly. (See Fig.1.)
- (3) Solder the short land sections on the pickup. (See Fig.2.)

Caution:

- Solder the short land sections on the pickup before disconnecting the flexible wire from the connector [CN102](#) on the MECHANISM CONTROL BOARD assembly. If the card wire is disconnected without attaching solder, the pickup may be destroyed by static electricity. (See Fig.2.)
- When attaching the MECHANISM CONTROL BOARD assembly, remove the solders from the short land sections after connecting the flexible wire to the connector [CN102](#) on the MECHANISM CONTROL BOARD assembly.

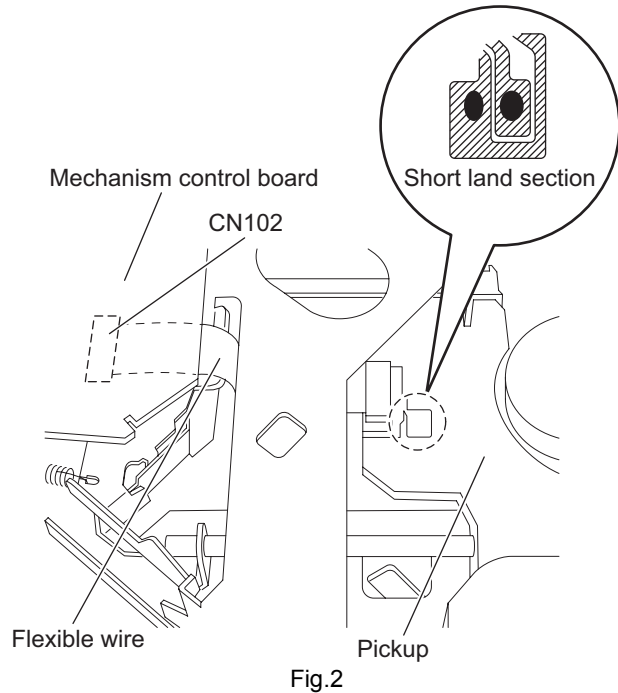
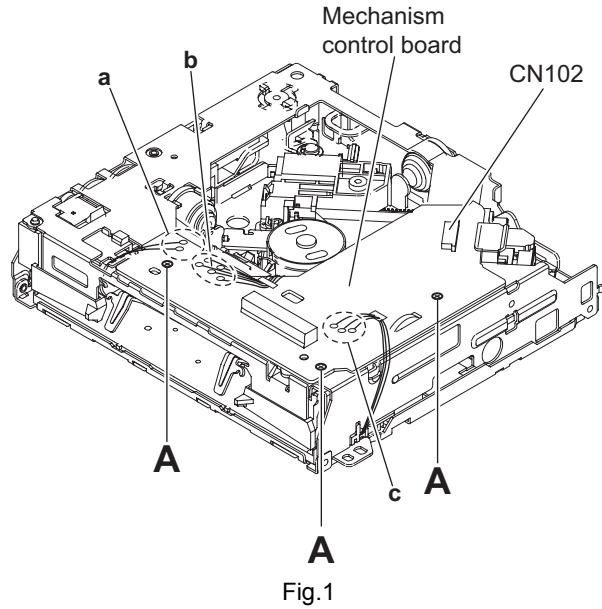

3.2.2 Removing the top cover (See Fig.3 to 5)

- Remove the MECHANISM CONTROL BOARD assembly.
 - From the front side of the CD MECHANISM assembly, change the hook position of the two roller springs. (See Fig.3.)
 - From the side of the CD MECHANISM assembly, remove the six screws **B** attaching the top cover. (See Fig.3 and 4.)
 - Take out the top cover in an upward direction. (See Fig.5.)

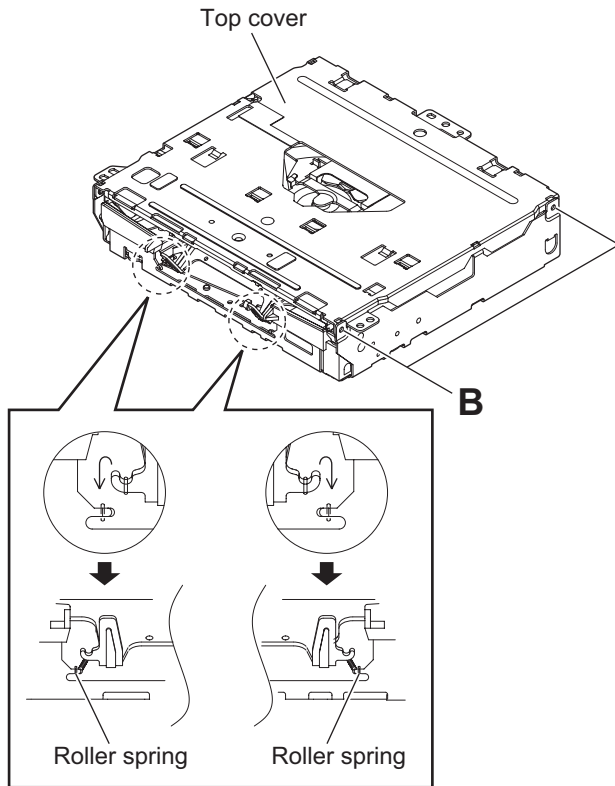

Fig.3

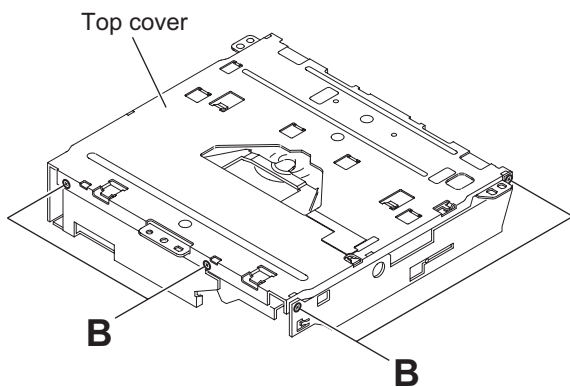

Fig.4

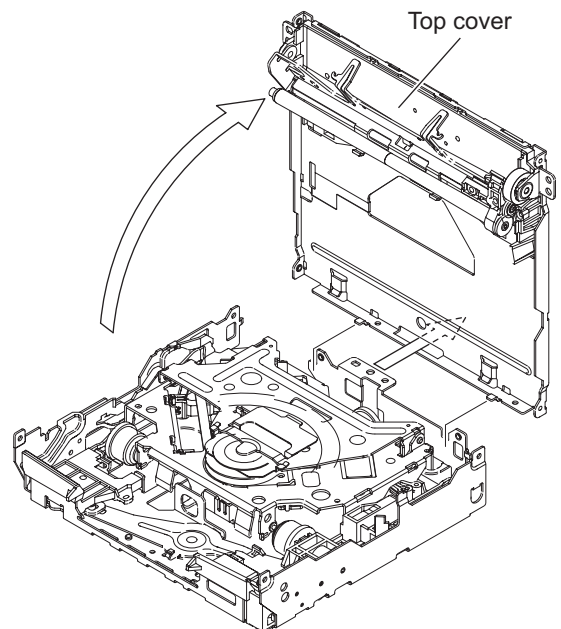

Fig.5

3.2.3 Removing the roller (See Fig.6)

- Remove the MECHANISM CONTROL BOARD assembly and top cover.
 - From the bottom side of the top cover, remove the screw **C** attaching the gear holder.
 - Remove the R.holder assembly from disc plate, and then take out the roller from R.holder assembly in the direction of the arrow.

Reference:

When attaching the R.ACT gear (2) and R.ACT gear (3), apply grease to the section **d** of R.holder assembly.

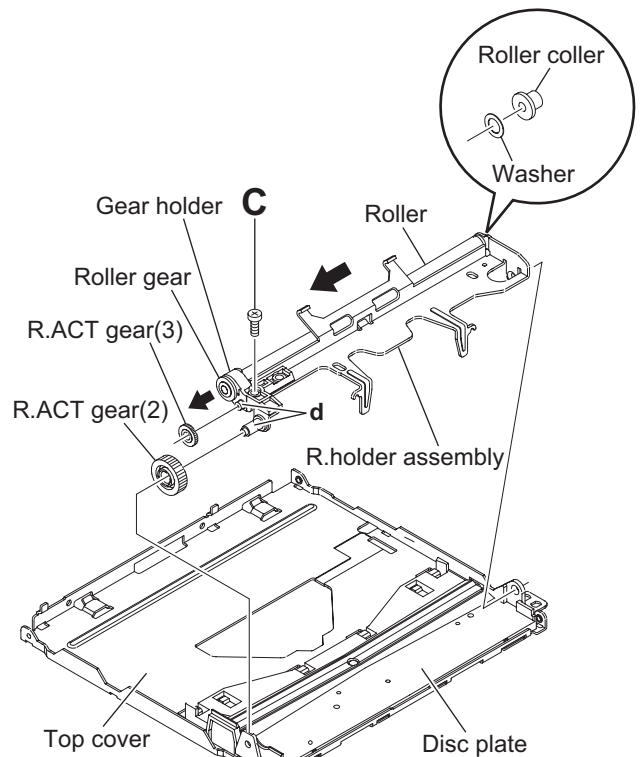
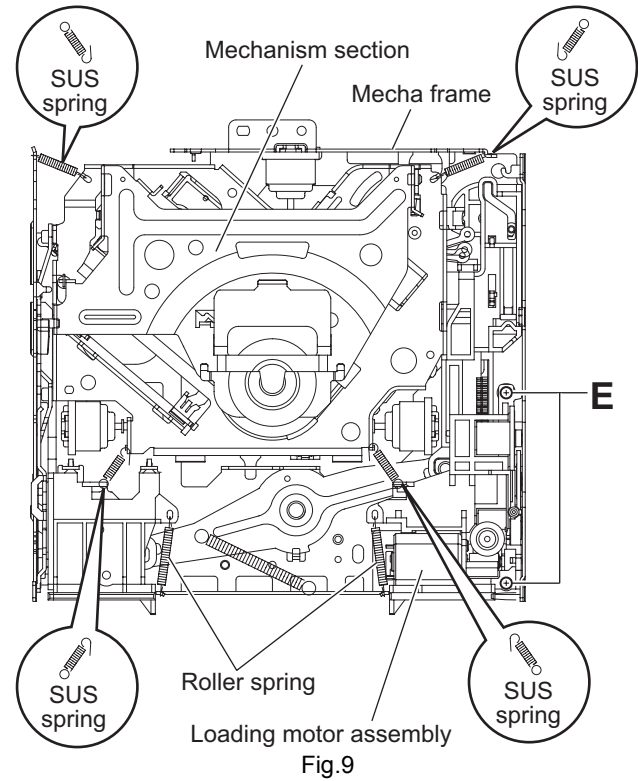
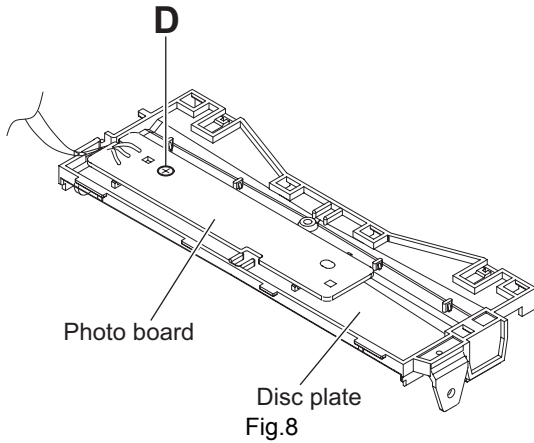
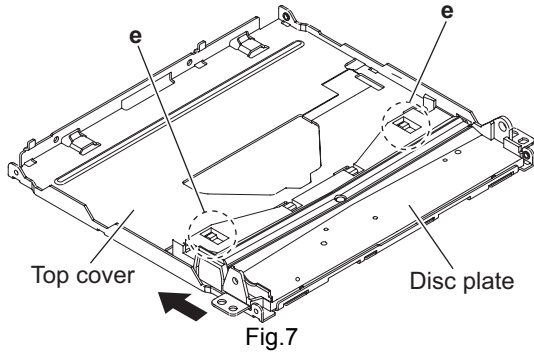

Fig.6

3.2.4 Removing the PHOTO BOARD assembly (See Fig.7 and 8)

- Remove the MECHANISM CONTROL BOARD assembly and top cover.
 - From the bottom side of the top cover, release the projection **e** from the notch of the disc plate. (See Fig.7.)
 - Take out the disc plate in the direction of the arrow. (See Fig.7.)
 - From the reverse side of the disc plate, remove the screw **D** attaching the PHOTO BOARD assembly. (See Fig.8.)



3.2.5 Removing the mechanism section (See Fig.9 and 10)

- Remove the MECHANISM CONTROL BOARD assembly and top cover.
 - From the top side of the CD MECHANISM assembly, remove the two screws **E** attaching the loading motor assembly. (See Fig.9.)
 - Remove the two roller springs on the top side of the mecha frame. (See Fig.9.)
 - Remove the four SUS springs on the top side of the mecha frame. (See Fig.9.)
 - Remove the link spring on the top side of the mecha frame. (See Fig.10.)
 - Release section **f** of the three dampers from the mecha frame. (See Fig.10.)

Reference:

When attaching the roller spring and SUS spring, keep direction before remove.

- Move the slide cam (R) assembly in the direction of the arrow, and then take out the mechanism section in an upward direction. (See Fig.10.)

Reference:

When attaching the mechanism section, apply grease to the section **g**. (See Fig.10.)

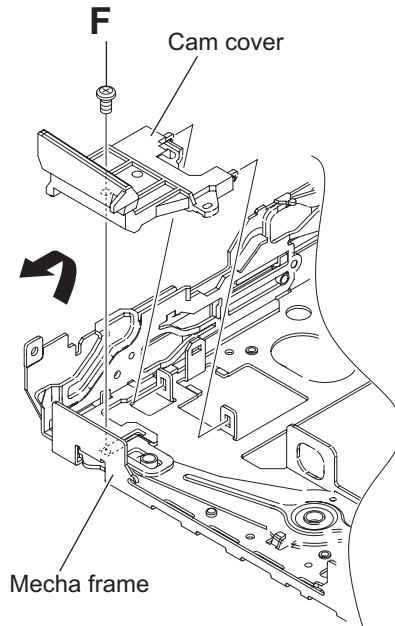

3.2.6 Removing the slide cam (L) (See Fig.11 to 13)

- Remove the MECHANISM CONTROL BOARD assembly, top cover and mechanism section.
 - From the top side of the mecha frame, remove the screw **F** attaching the cam cover. (See Fig.11.)
 - Take out the cam cover from mecha frame in an upward direction. (See Fig.11.)
 - Take out the slide cam (L) in the direction of the arrow. (See Fig.12.)

Reference:

When attaching the slide cam (L), apply grease to the section **h**. (See Fig.13.)

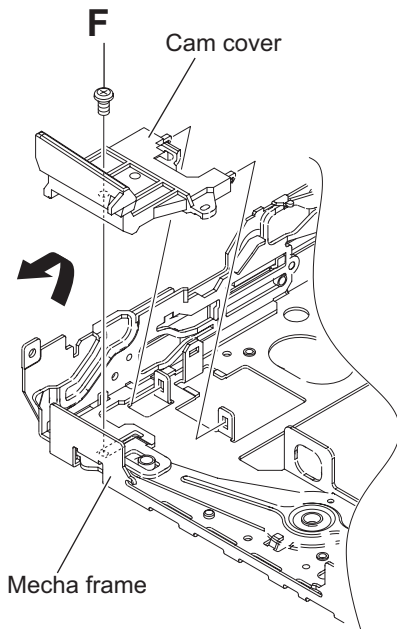

Fig.11

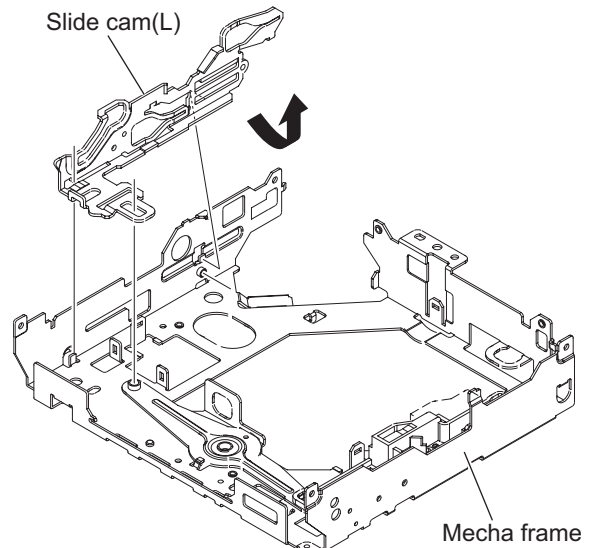

Fig.12

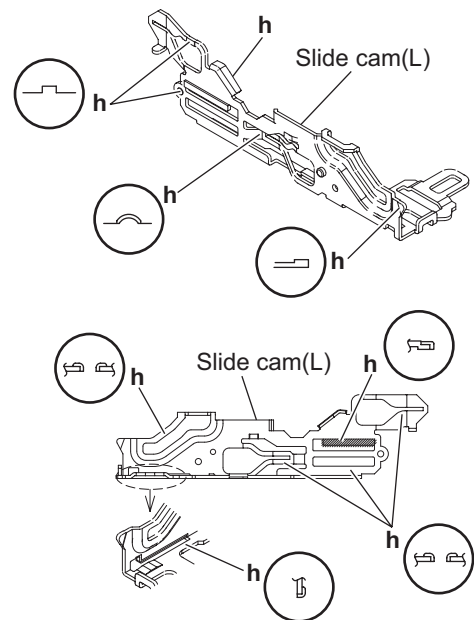

Fig.13

3.2.7 Removing the F.lock lever and slide cam (R) (See Fig.14 and 15)

- Remove the MECHANISM CONTROL BOARD assembly, top cover and mechanism section.
 - From the top side of the mecha frame, take out the slide cam (R) assembly in an upward direction. (See Fig.14.)
 - Rotate the F.lock lever in the direction of the arrow 1, and then take out the direction of the arrow 2. (See Fig.14.)

Reference:

When attaching the slide cam (R) assembly, the f.lock lever and the link arm apply grease to the section **h**. (See Fig.14 and 15.)

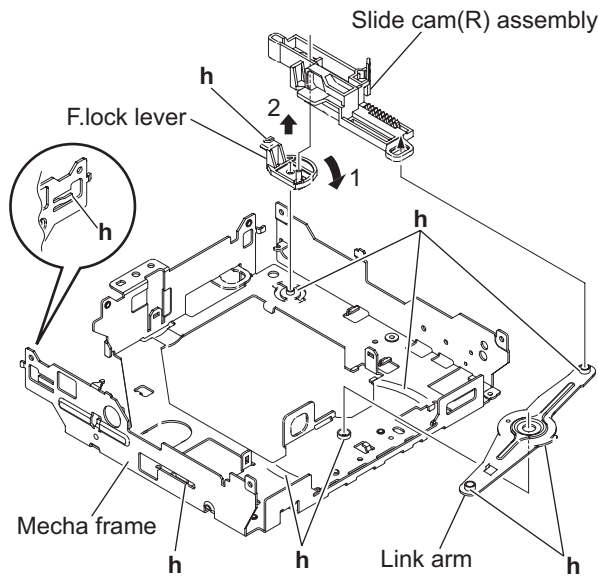

Fig.14

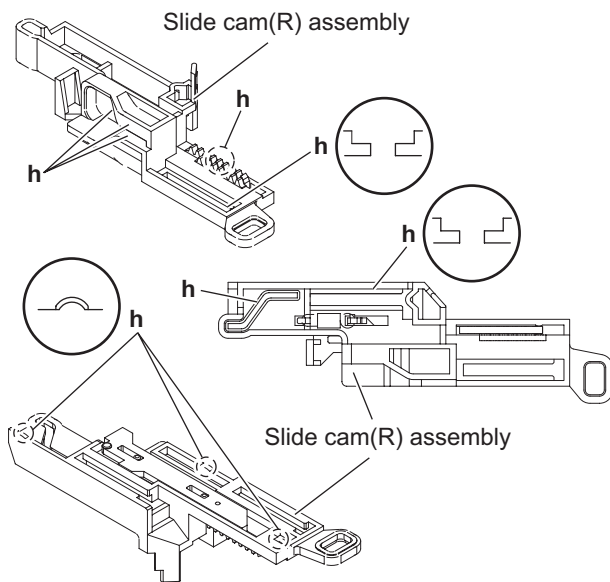

Fig.15

3.2.8 Removing the damper (See Fig.16)

- Remove the MECHANISM CONTROL BOARD assembly, top cover and mechanism section.

From the mechanism section, pull out the three dampers in the direction of the arrow.

Reference:

Before inserting the shaft to the dampers, apply IPA to the pocket **j** of damper.

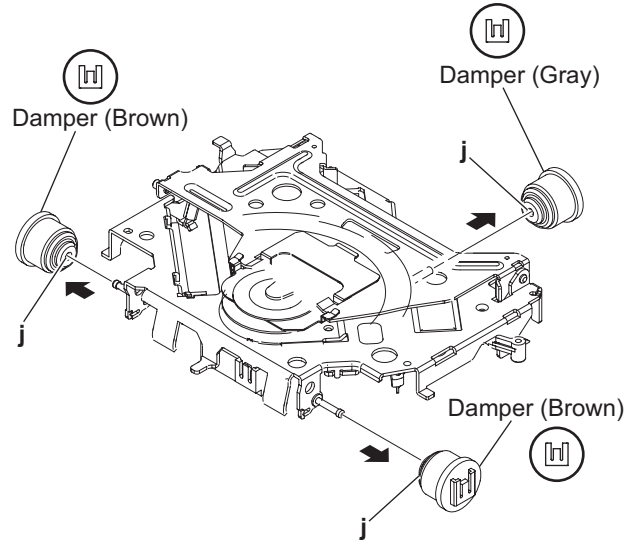

Fig.16

3.2.9 Removing the clumper assembly (See Fig.17)

- Remove the MECHANISM CONTROL BOARD assembly, top cover and mechanism section.
 - From the top side of the mechanism section, release the clumper spring.
 - Move the clumper assembly in the direction of the arrow, and then release the joints (**k** and **m**).
 - Take out the clumper assembly from the T.M chassis assembly.

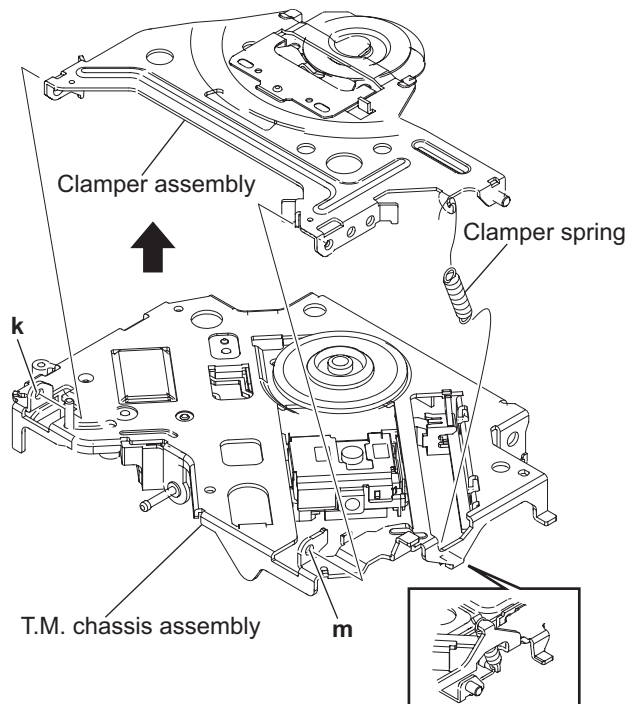

Fig.17

3.2.10 Removing the feed motor (See Fig.18 and 19)

- Remove the MECHANISM CONTROL BOARD assembly, top cover, mechanism section and clamber assembly.
 - From the bottom side of the T.M chassis assembly, remove the two screws **G** attaching the feed motor assembly. (See Fig.18.)
 - Remove the two screws **H** attaching the feed motor to f.motor holder. (See Fig.19.)

Reference:

When attaching the f. wheel gear, trigger arm and feed motor, apply grease to the sections (**n**, **p** and **q**). (See Fig.18 and 19.)

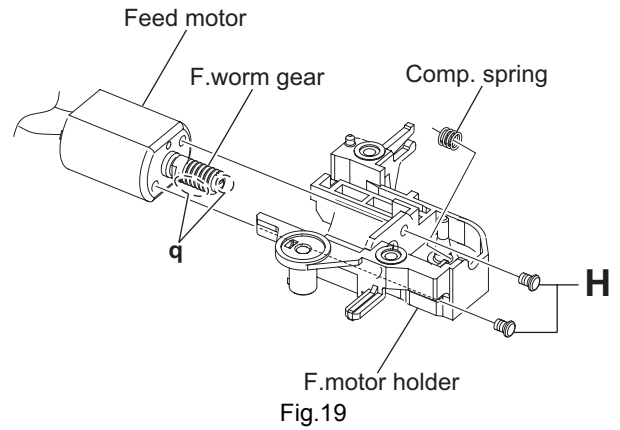

Fig.19

3.2.11 Removing the SWITCH BOARD assembly (See Fig.18)

- Remove the MECHANISM CONTROL BOARD assembly, top cover, mechanism section, clamber assembly and feed motor assembly. From the bottom side of the T.M chassis assembly, take out the SWITCH BOARD assembly in an upward direction from T.M chassis assembly.

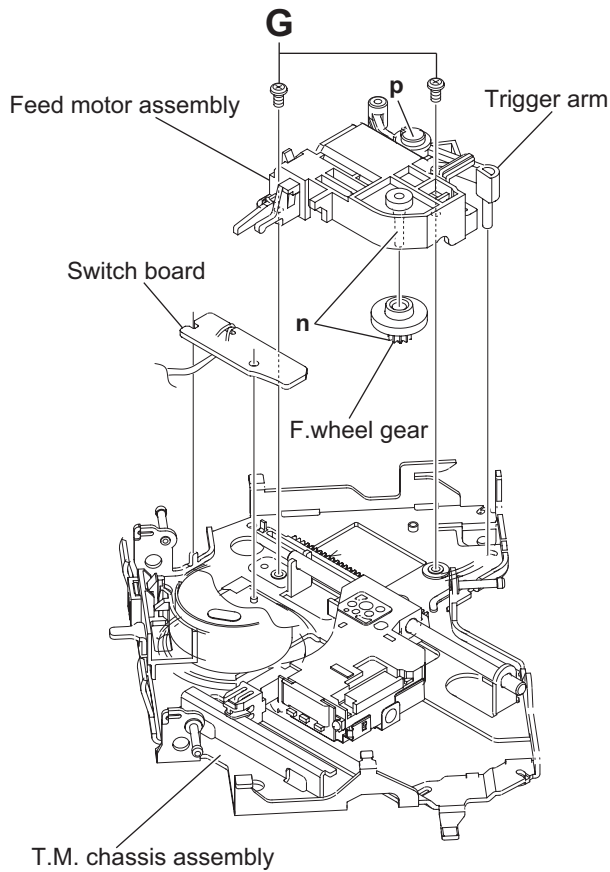

Fig.18

3.2.12 Removing the loading motor (See Fig.20)

- Remove the MECHANISM CONTROL BOARD assembly, top cover, mechanism section and clamber assembly.
 - From the right side of the L.M base assembly, remove the two screws **J** attaching the loading motor.
 - Take out the loading motor in the direction of the arrow from the L.M base assembly.

Reference:

When attaching the loading motor, apply grease to the section **r**.

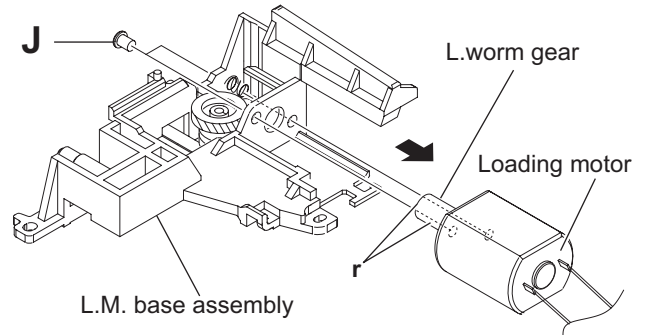

Fig.20

3.2.13 Removing the pickup assembly (See Fig.21 to 22)

- Remove the MECHANISM CONTROL BOARD assembly, top cover, mechanism section, clamber assembly and feed motor assembly.

Caution:

- Do not touch section **u** on the pickup assembly. (See Fig.21 and 22.)
- From the bottom side of the T.M chassis assembly, move the pickup assembly in the direction of the arrow from the T.M chassis assembly. (See Fig.21.)
 - Pull out the main shaft. (See Fig.21.)
 - Remove the screw **K** attaching the pickup to the rack plate. (See Fig.22.)

Reference:

When attaching the loading motor, apply grease to the sections **s** and **t**. (See Fig.21.)

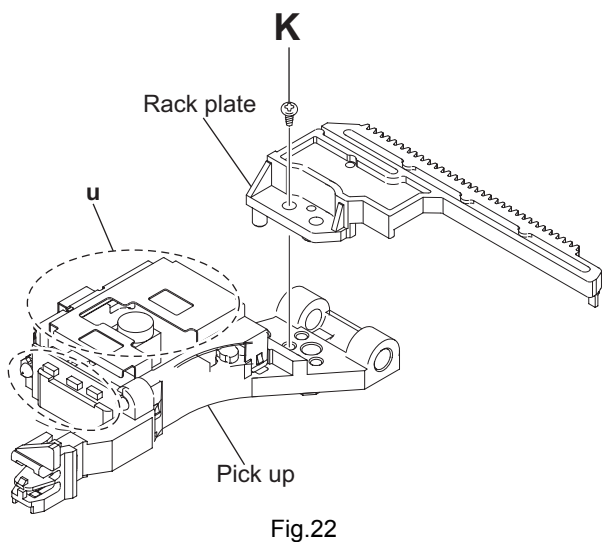
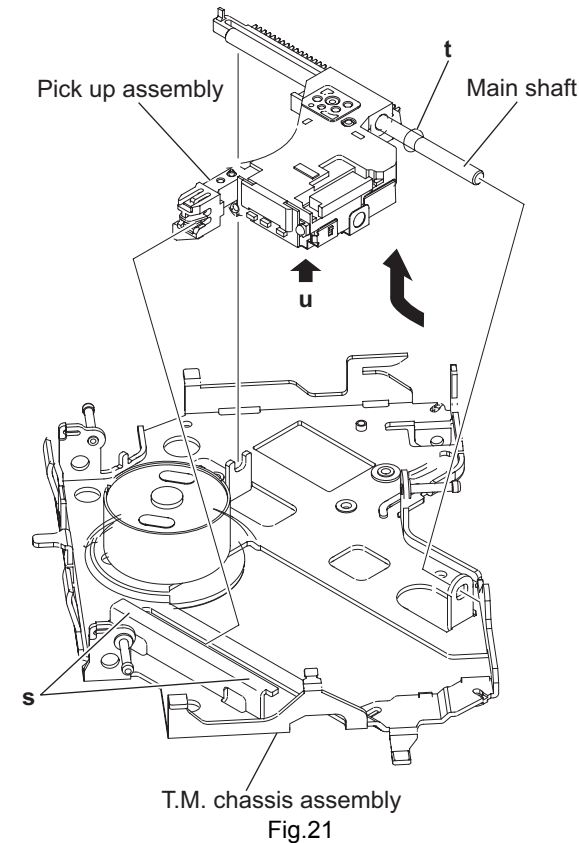

3.2.14 Removing the spindle motor (See Fig.23 and 24)

- Remove the MECHANISM CONTROL BOARD assembly, top cover, mechanism section, clamber assembly, feed motor assembly and pickup assembly.
- From the top side of the T.M chassis assembly, remove the CD T.table assembly from the spindle motor. (See Fig.23.)
 - Remove the two screws **L** attaching the spindle motor. (See Fig.23.)
 - Take out the spindle motor from the bottom side of the T.M chassis assembly. (See Fig.23.)

Reference:

When attaching the CD T.table assembly to the spindle motor shaft, apply loctite 460 to inside the CD T.table assembly. (See Fig.24.)

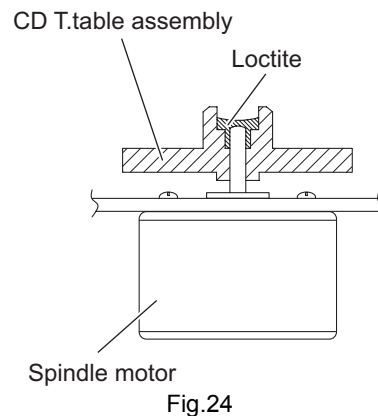
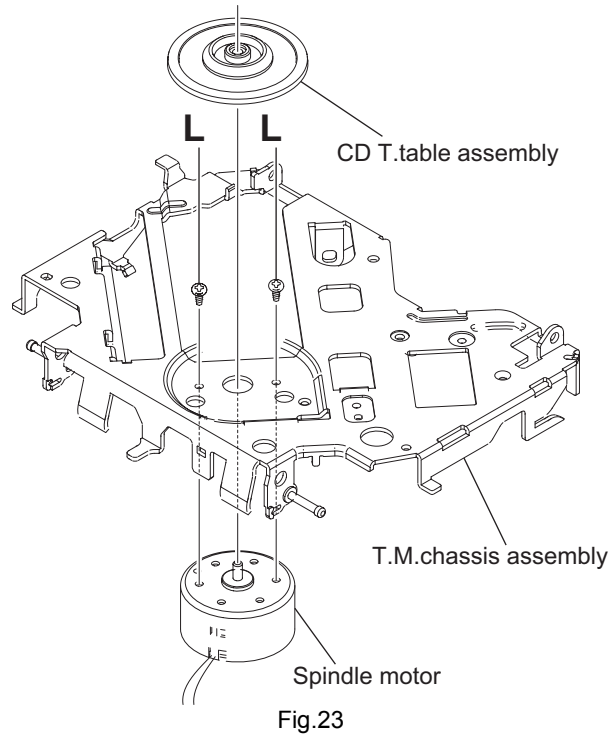

SECTION 4 ADJUSTMENT

4.1 Adjustment

■ Test instruments required for adjustment

- (1) Digital oscilloscope (100MHz)
- (2) Digital tester
- (3) Test Disc
- (4) Extension cable : EXTCD004-28P

■ Standard volume position

Balance and Bass & Treble volume : Indication "0"
Loudness : OFF

■ Standard measuring conditions

Power supply voltage DC14.4V(10.5 to 16V)
Load impedance 20K ohm (2 Speakers connection)
Output Level Line out 2.5V (Vol. MAX)

■ Dummy load

Exclusive dummy load should be used for AM, and FM. For FM dummy load, there is a loss of 6dB between SSG output and antenna input. The loss of 6dB need not be considered since direct reading of figures are applied in this working standard.

■ How to connect the extension cable for adjusting

Be sure to attach the heat sink and rear bracket onto the power amplifier IC and regulator IC respectively, before supply the power.

If voltage is applied without attaching these parts, the power amplifier IC and regulator IC will be destroyed by heat.

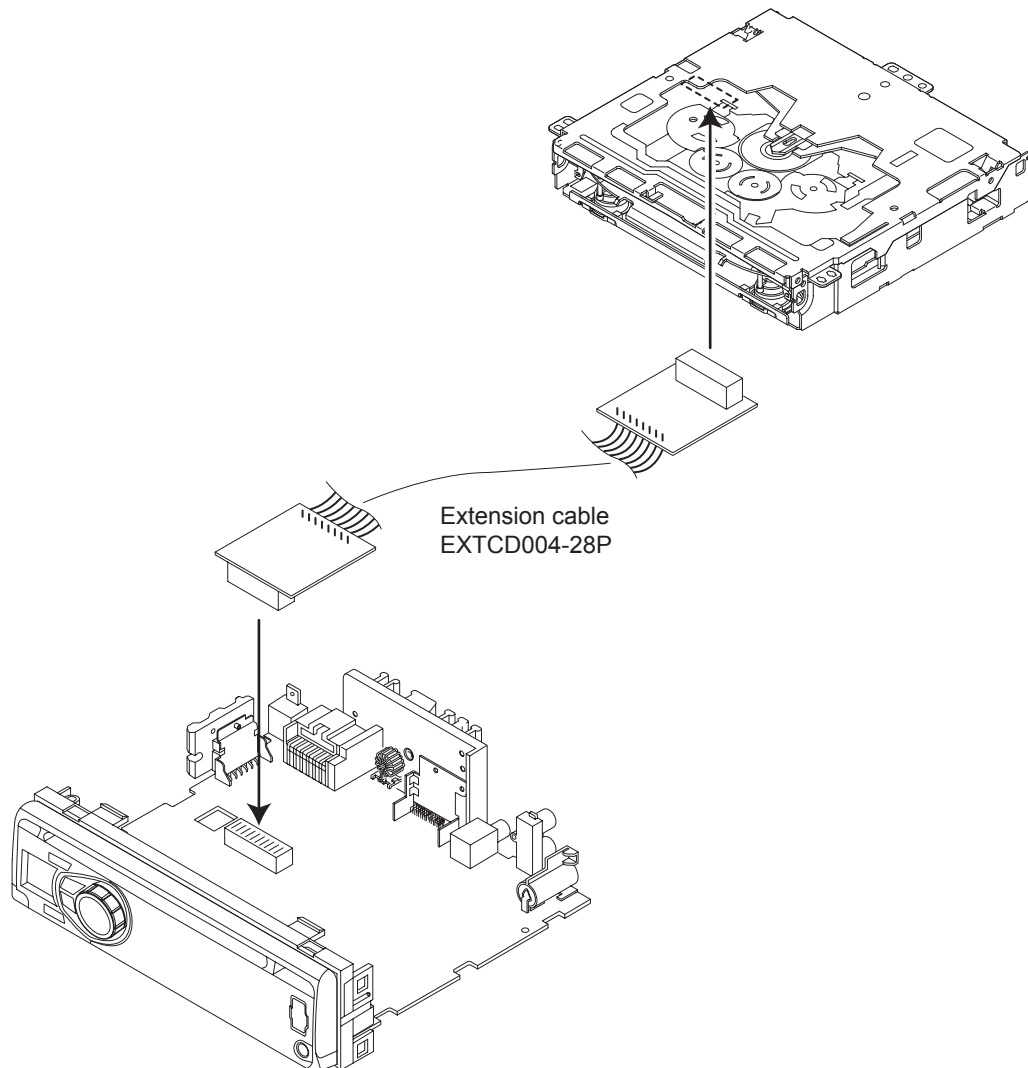

4.2 Service Mode

Operating key: [MENU] → [DOWN] (3 sec)

Navigation key : Press [SEL] in any main display item to select that option.

Volume Knob Turn: forward and backward selection

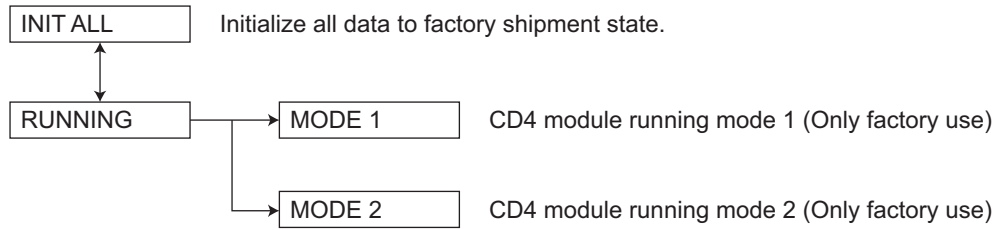

Note : A disc is inserted, and it is displayed only at the time of CD function.

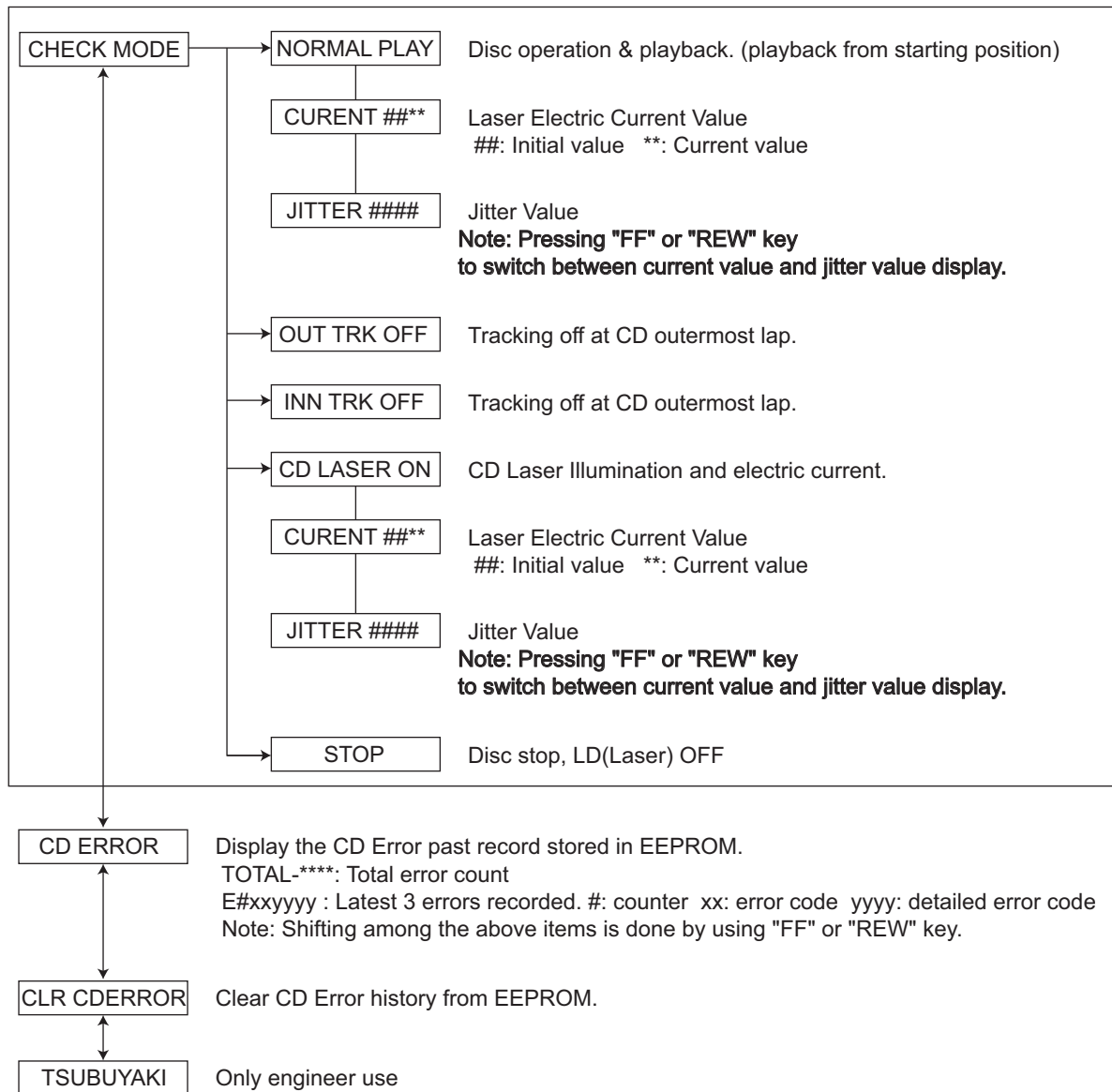

4.3 Tuner service mode

Key operation (FM, AM and DAB mode)

Enter service mode: [SEL]→ [MENU] (3 sec)

Exit service mode: press [ENTER] (SEL) key.

Go to next item: press [DISP] key

Back to previous item: press [BACK] key

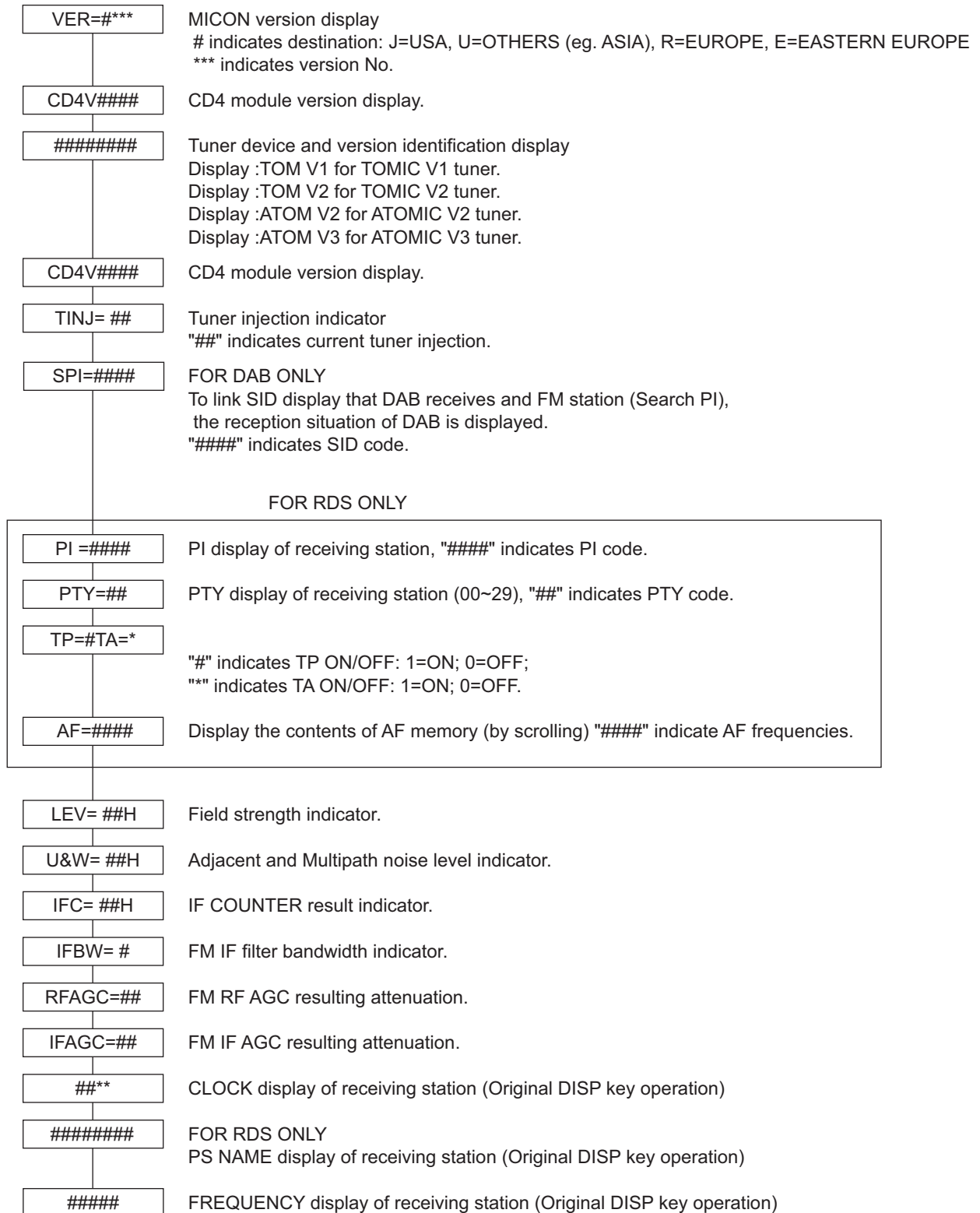

4.4 Error code

4.4.1 Mechanical Error Detail Codes

Condition	Details	Error Code	Detail Code
LOADING Error	Error without SW change in LOAD when time-out is done		
B1 time out	When there is no change in the state of the switch from the state with DISC forward.	09	0011
C1 time out	When there is no change in the state of the switch from the state that DISC is drawn in a half.	09	0012
B2 time out	When there is no change in the state of the switch from the state that DISC is in the interior.	09	0015
EJECT Error	Error without SW change in EJECT when time-out is done.		
B1 time out	When there is no change in the state of the switch from the state that DISC is in the interior.	01	0023
C2 time out	When there is no change in the state of the switch from the state that DISC is drawn in a half.	01	0026
B2 time out	When there is no change in the state of the switch in EJECT from initial LOAD ERROR.	01	0027
FORCE EJECT Error	Transition to Force EJECT waiting or Force EJECT transition from error Error by abnormal SW.		
E1 FORCE EJECT ERROR	When detect abnormal SW from the state of NO DISC	01	0041
E2 FORCE EJECT ERROR	When detect abnormal SW from the state with DISC forward in LOAD.	01	0042
E3 FORCE EJECT ERROR	When detect abnormal SW from the initial state.		0043
E5 FORCE EJECT ERROR	When detect abnormal SW from the state that half DISC is drawn in LOAD and EJECT.	01	0045
E7 FORCE EJECT ERROR	When detect abnormal SW from the state that DISC is in the interior in LOAD and EJECT.	01	0047
E8 FORCE EJECT ERROR	When receive Force EJECT key after it makes an error from Force EJECT.	01	0048
E9 FORCE EJECT ERROR	When receive Force EJECT key after it makes an error from LOAD error or EJECT error.	01	0049
Error in Running mode			
Case 1	When DISC was extracted or fall in EJECT END and EJECT START.	09	0031
Case 2	When DISC is pushed in EJECT END.	09	0032

4.4.2 Disc error code

Condition	Details	Error Code	Detail Code
TOC READING Error	When it hasn't completed CD TOC reading.	84	0059
1'st track access Error	It doesn't end even if the first track access passes 30sec after the TOC reading ends in the running mode.	80	0060
Last track access Error	It doesn't end even if the last track access passes 30sec after the first track ends in the running mode.	80	0061
NODISC judgement	It be judged NODISC.	80	0090
NO DISC with start failure	Not possible to start.	80	0091
Stopped with no playback	When it was stopped in playback in the running mode.	80	0093
Logical format NG	Analysis of logical format is impossible or it does not correspond to logical formats.	80	0094

SECTION 5 TROUBLESHOOTING

16 PIN CORD DIAGRAM (for KD-R400)

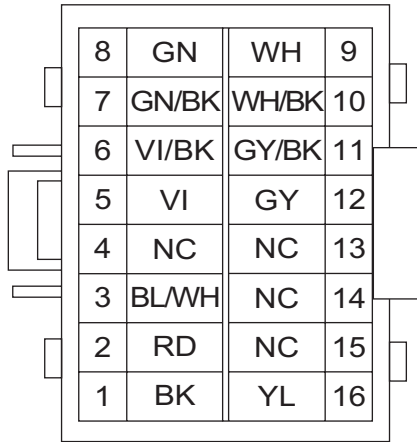

BK	Black	VI	Violet
RD	Red	GN	Green
BL	Blue	GY	Gray
WH	White	YL	Yellow

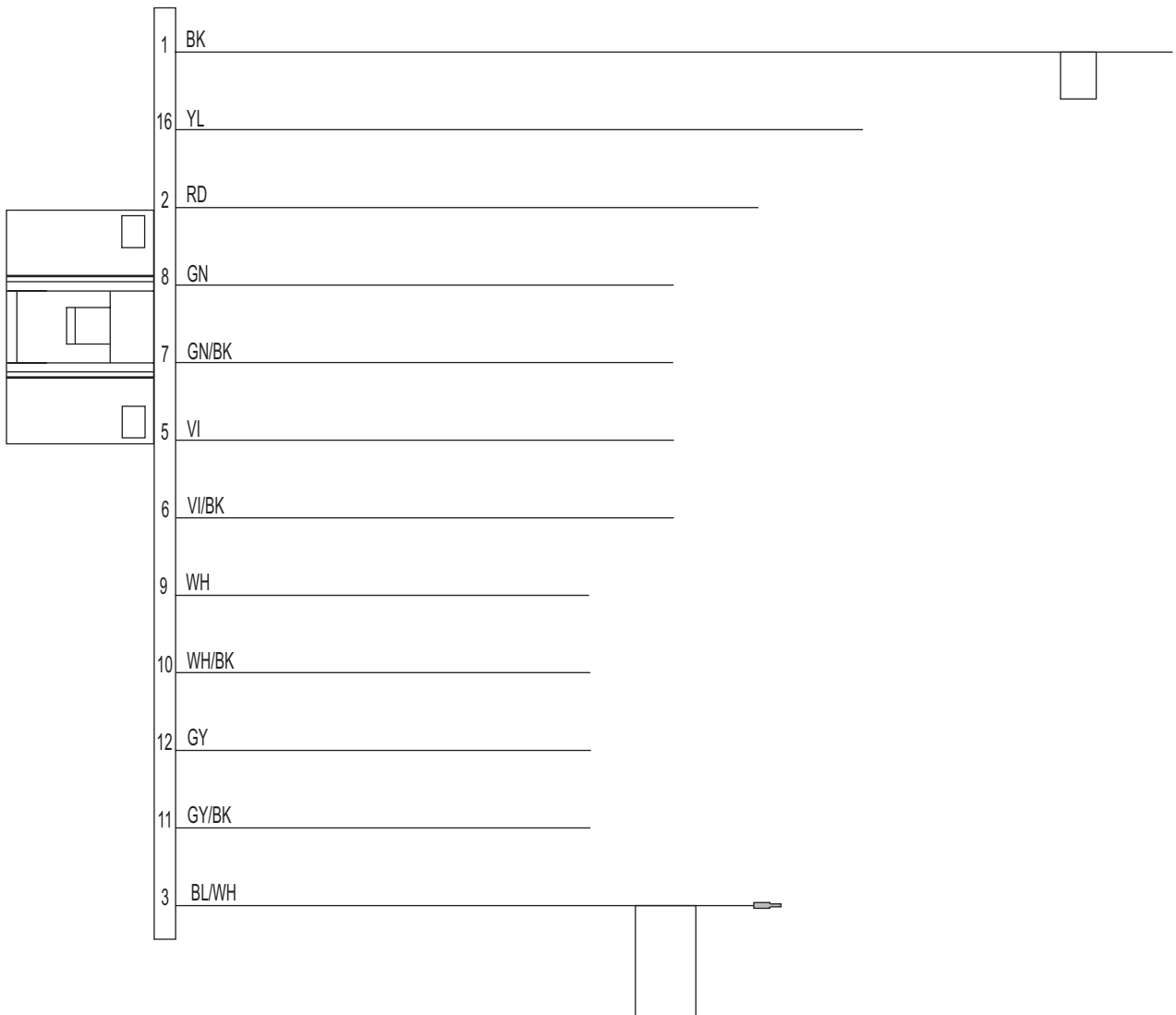

16 PIN CORD DIAGRAM (for KD-R401, KD-R402, KD-R407, KD-R501)

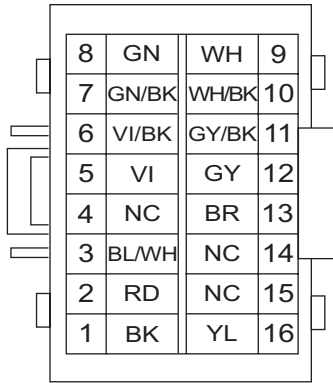

BK	Black	GN	Green
RD	Red	GY	Gray
BL	Blue	BR	Brown
WH	White	YL	Yellow
VI	Violet		

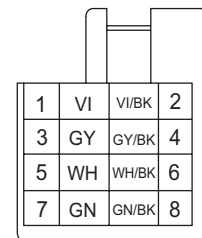
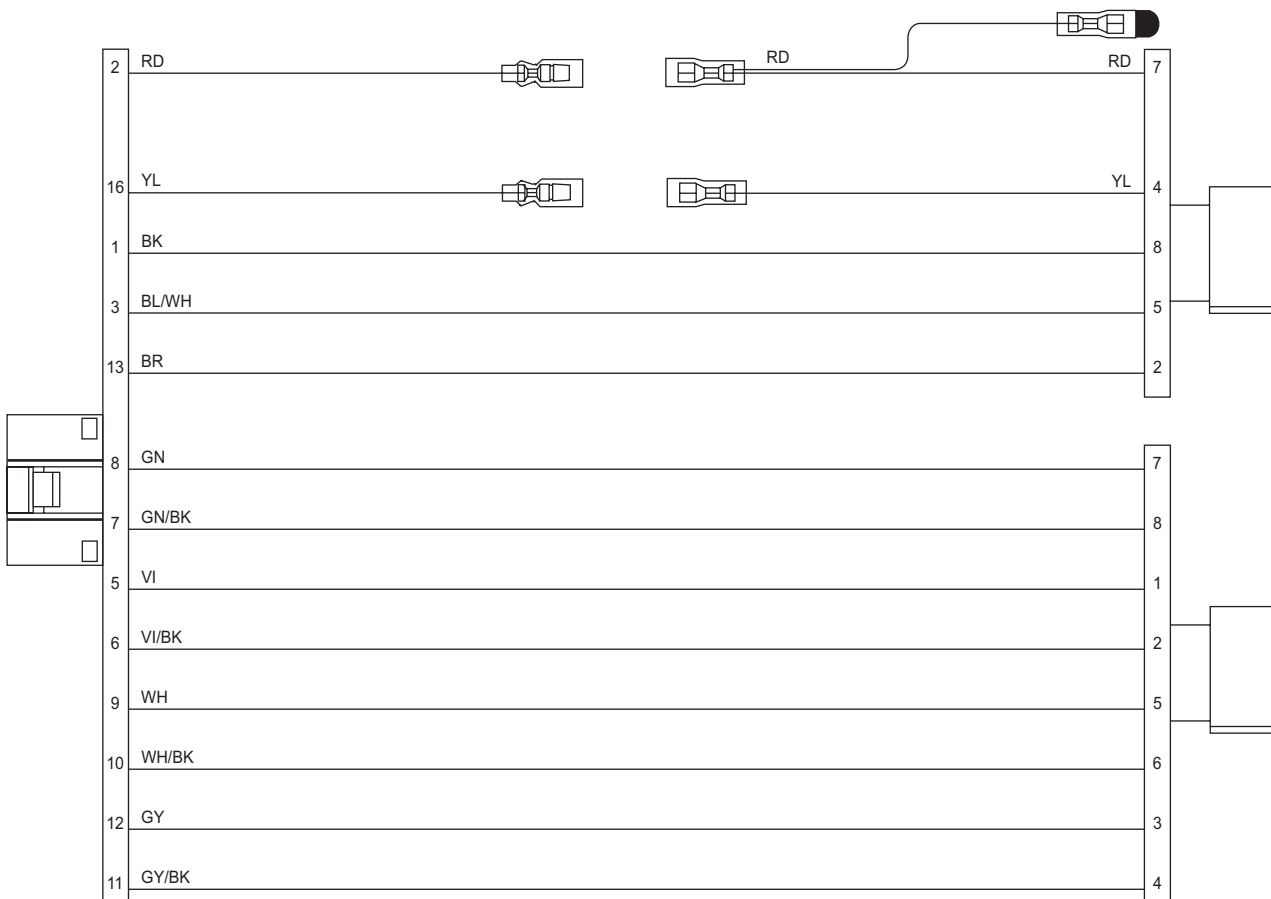
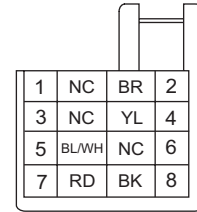

16 PIN CORD DIAGRAM (for KD-R504, KD-R505, KD-R506, KD-R508)

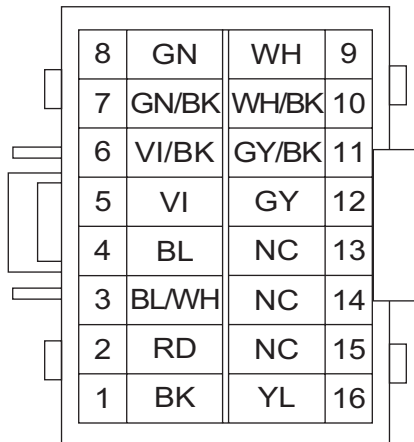

BK	Black	VI	Violet
RD	Red	GN	Green
BL	Blue	GY	Gray
WH	White	YL	Yellow

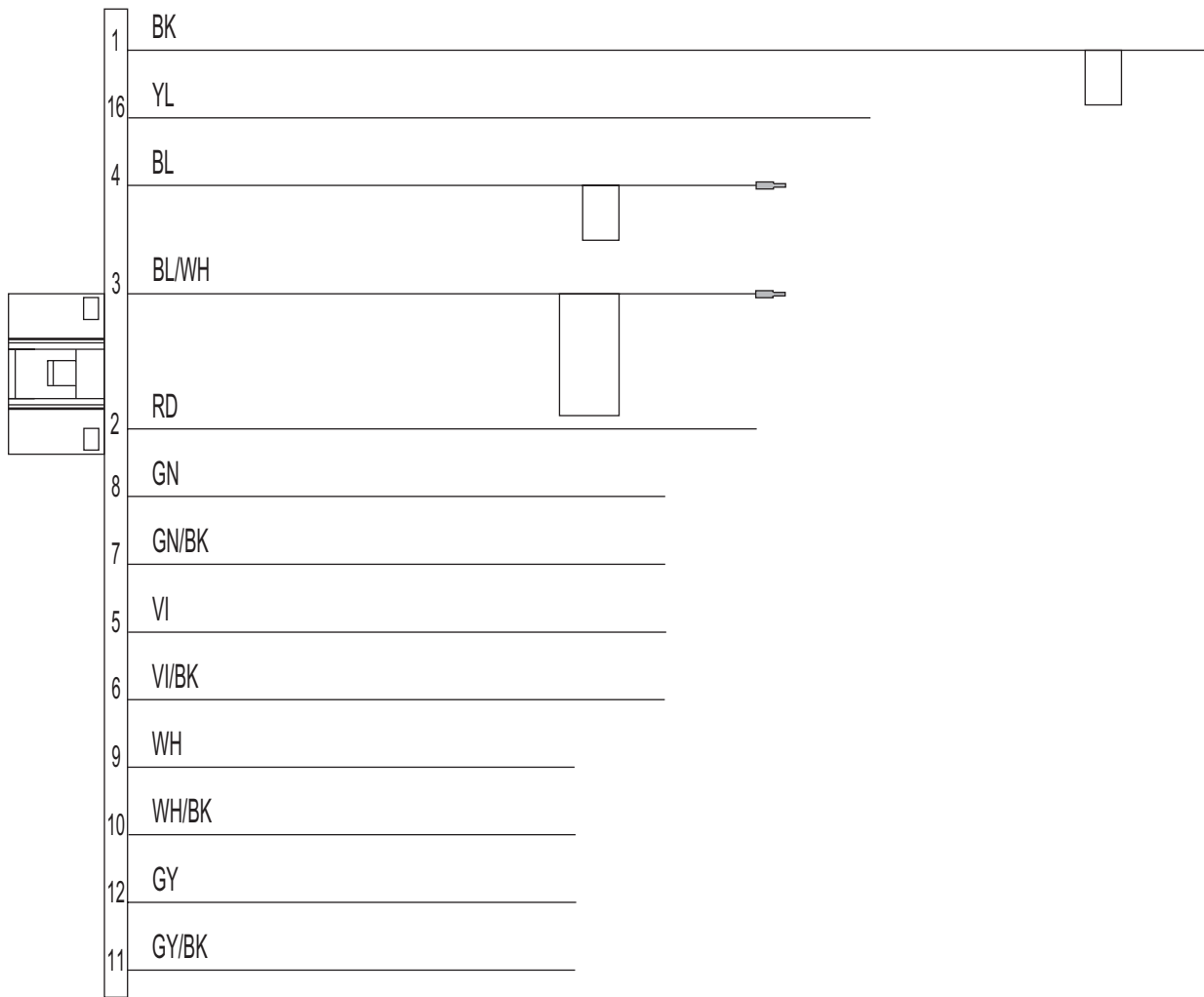

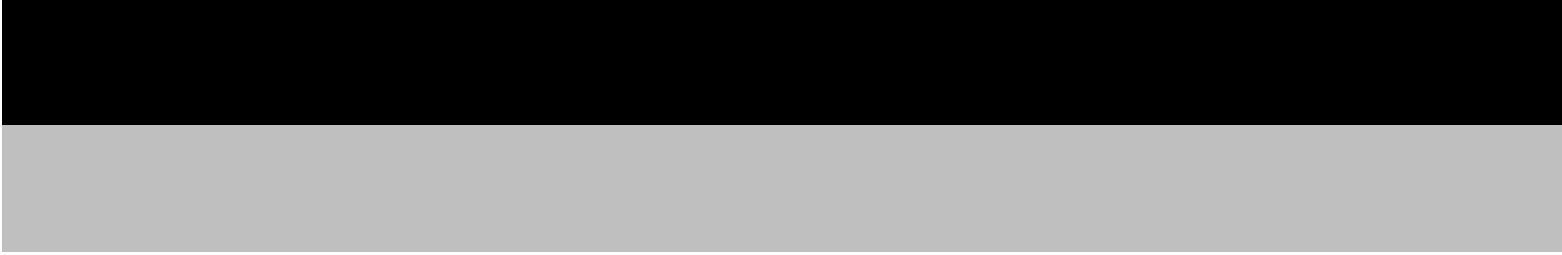

JVC

Victor Company of Japan, Limited
Mobile Entertainment Division 10-1,1chome,Ohwatari-machi,Maebashi-city,371-8543,Japan

(No.MA430<Rev.001>)

Printed in Japan
VPT

JVC

SCHEMATIC DIAGRAMS

CD RECEIVER

**KD-R400J, KD-R401E, KD-R401EX
KD-R401EY, KD-R401EU, KD-R402EY
KD-R407EE, KD-R501E, KD-R501EX
KD-R501EY, KD-R501EU, KD-R504UI
KD-R505U, KD-R505UN, KD-R505UT
KD-R505UH, KD-R506U, KD-R506UN
KD-R506UT, KD-R506UH, KD-R508UF**

DVD-ROM No.SML2008Q3

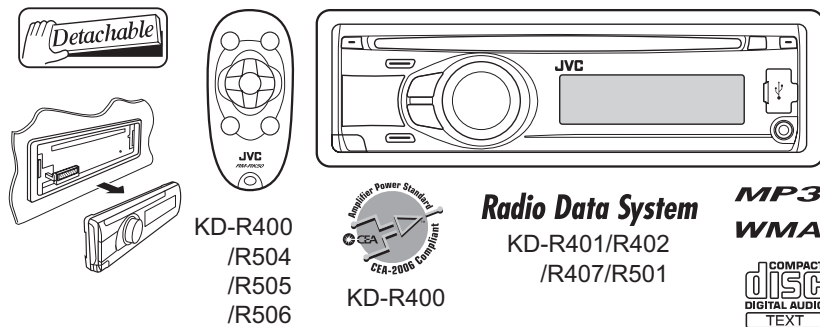

KD-R400
/R504
/R505
/R506

Amplifier Power Standards
CEA-2006 Compliant
KD-R400

Radio Data System
KD-R401/R402
/R407/R501

MP3
WMA
COMPACT
disc
DIGITAL AUDIO
TEXT

Lead free solder used in the board (material : Sn-Ag-Cu, melting point : 219 Centigrade)
Lead free solder used in the board (material : Sn-Cu, melting point : 230 Centigrade)

Contents

Block diagram	2-1
Standard schematic diagrams	2-3
Printed circuit boards	2-13 to 16

Safety precaution



CAUTION Burrs formed during molding may be left over on some parts of the chassis. Therefore, pay attention to such burrs in the case of performing repair of this system.



CAUTION Please use enough caution not to see the beam directly or touch it in case of an adjustment or operation check.

< MEMO >

Block diagram

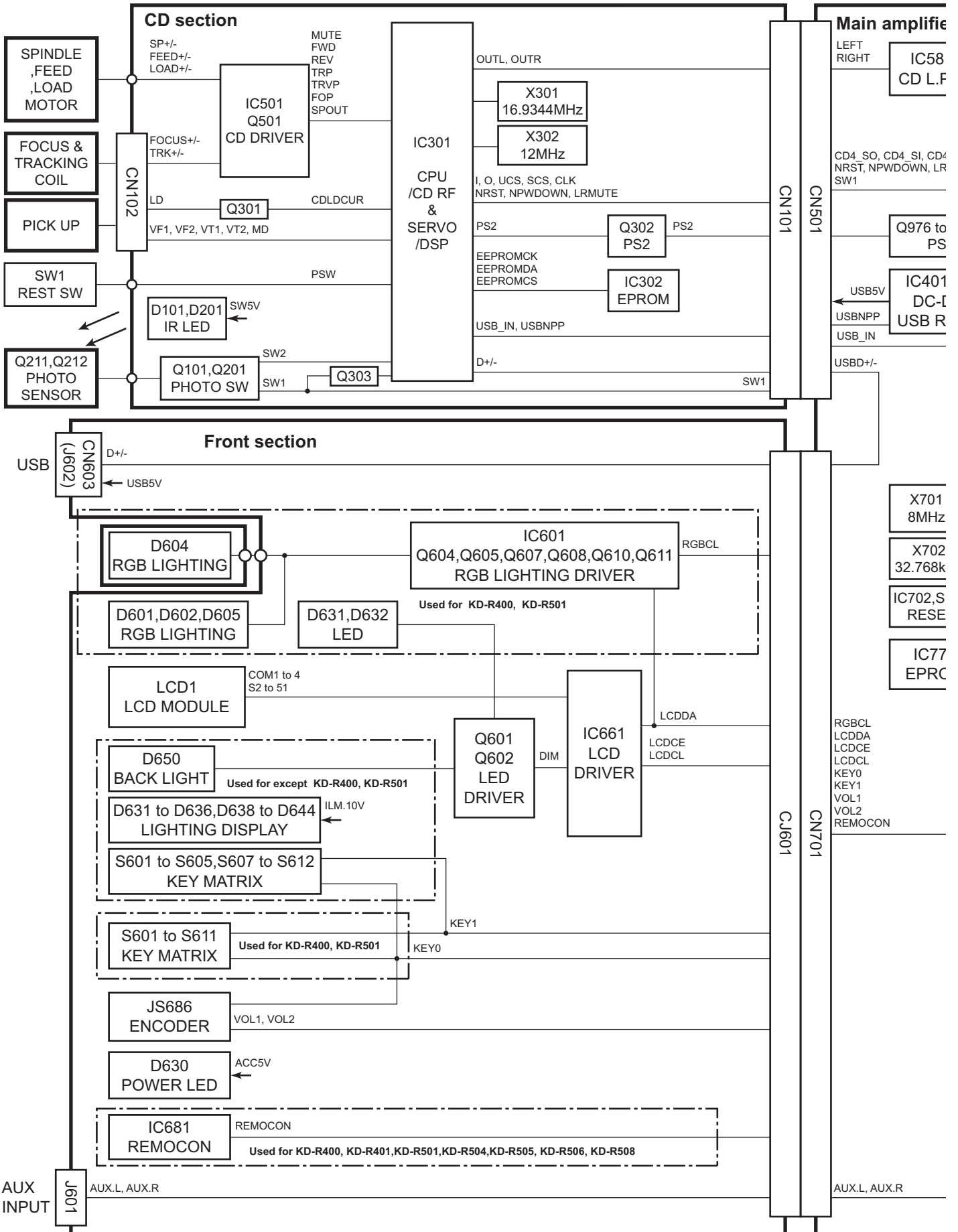

Amplifier & System control section

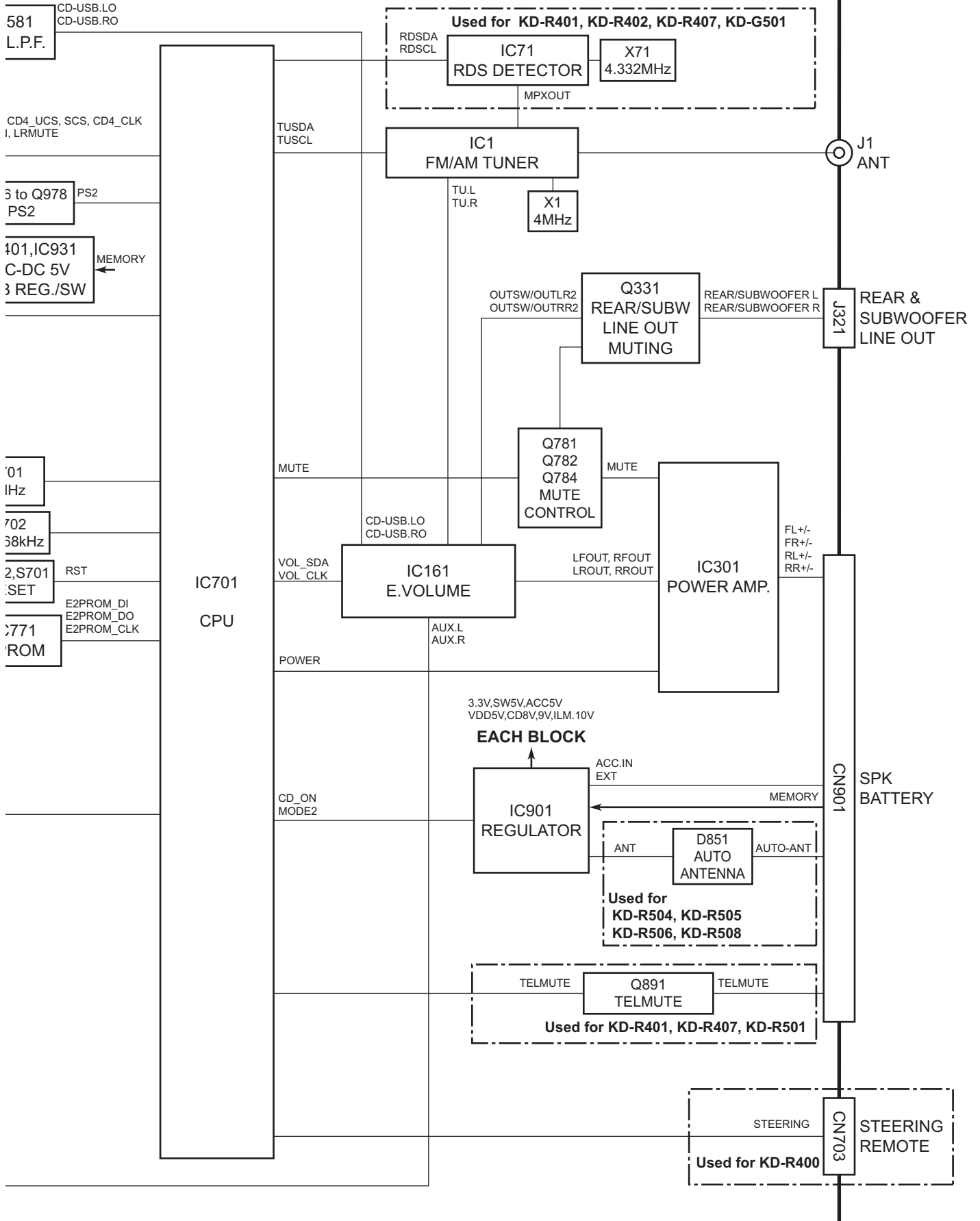

Standard schematic diagrams

■ Main section (for KD-R400J/501E series)

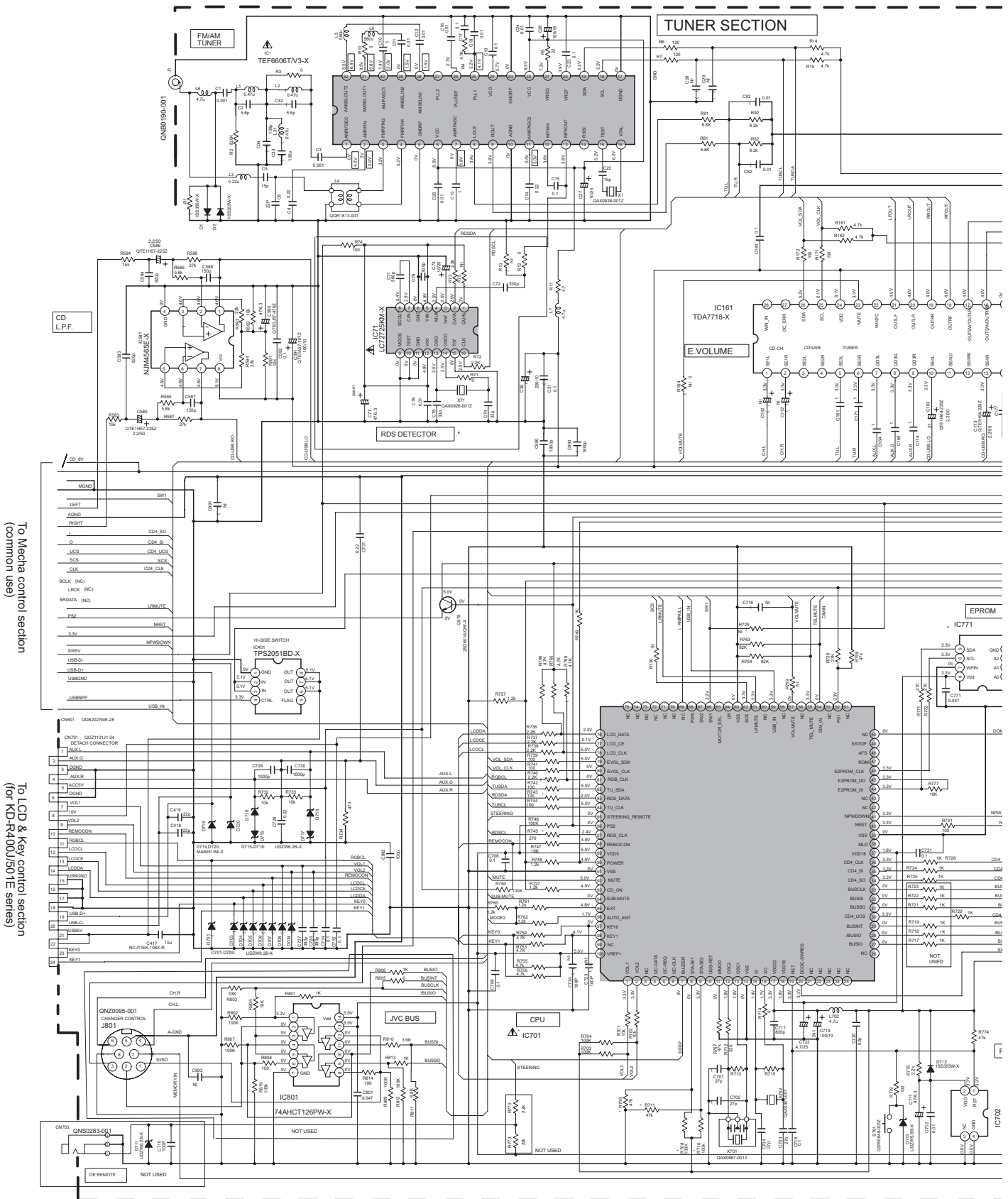

- NOTES
1. VOLTAGES ARE DC-MEASURED WITH A DIGITAL VOLT METER WITHOUT INPUT SIGNAL CONDITION—FM MODE. AM MODE MODE.
 2. UNLESS OTHERWISE SPECIFIED ALL RESISTORS ARE 1/16W 5% METAL GLAZE RESISTOR. ALL CAPACITORS ARE 50V OR 25V CERAMIC CAPACITOR. ALL RESISTANCE VALUES ARE IN OHM. ALL CAPACITANCE VALUES ARE IN uF(P=pF) ALL E.CAPACITORS ARE SHOWN IN THE FORM OF CAPACITANCE(uF)RATED VOLTAGE(V) COMPONENTS IN () INDICATE NOT USE.
 - 3.

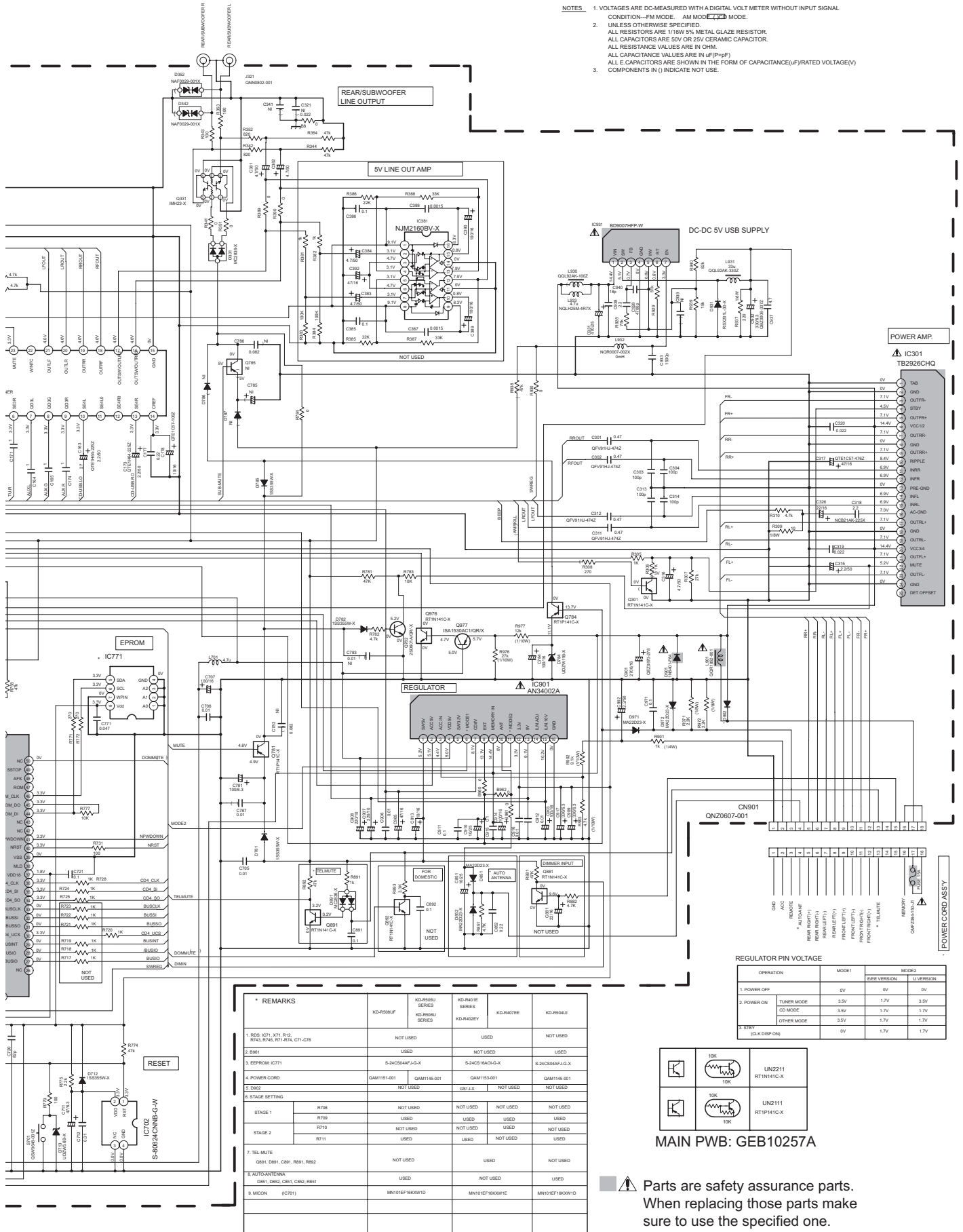

REGULATOR PIN VOLTAGE

OPERATION	MODE1	MODE2	U-VERSION
1. POWER OFF	0V	0V	0V
2. POWER ON	TUNER MODE CD MODE	3.5V 1.7V	3.5V 1.7V
3. STBY	OTHER MODE CLK-DISP ON	3.5V 0V	1.7V 1.7V

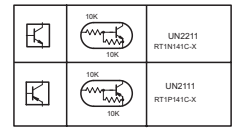

MAIN PWB: GEB10257A

* REMARKS

	KD-R506UF	KD-R50M SERIES KD-R506G SERIES	KD-R401E SERIES KD-R402EY	KD-R407EE	KD-R604L
1. R06: IC71, X71, R12, R043, R745, R71, R74, C71-C78	NOT USED	USED	USED	NOT USED	NOT USED
2. B91	USED	NOT USED	NOT USED	USED	USED
3. EEPROM IC771	S-24C32A4F-J4-G-X	S-24C32A4F-J4-G-X	S-24C318A0R-G-X	S-24C32A4F-J4-G-X	S-24C32A4F-J4-G-X
4. POWER CORD	QAM1151-001	QAM1145-001	QAM1153-001	QAM1153-001	QAM1153-001
5. D02	NOT USED	NOT USED	IS11LX	NOT USED	NOT USED
6. STAGE SETTING					
STAGE 1	R706	NOT USED	NOT USED	NOT USED	NOT USED
	R709	USED	USED	USED	USED
STAGE 2	R710	NOT USED	NOT USED	USED	NOT USED
	R711	USED	USED	NOT USED	USED
7. TEL-MUTE	Q81, D81, C81, R81, R82	NOT USED	USED	NOT USED	NOT USED
8. AUTO-ANTENNA	D81, D82, C81, C82, R81	USED	NOT USED	USED	NOT USED
9. MOON (IC701)	MM101EF18K0W1D	MM101EF18K0W1E	MM101EF18K0W1D	MM101EF18K0W1D	MM101EF18K0W1D

Parts are safety assurance parts. When replacing those parts make sure to use the specified one.

LCD & Key control section (for KD-R400J/501E series)

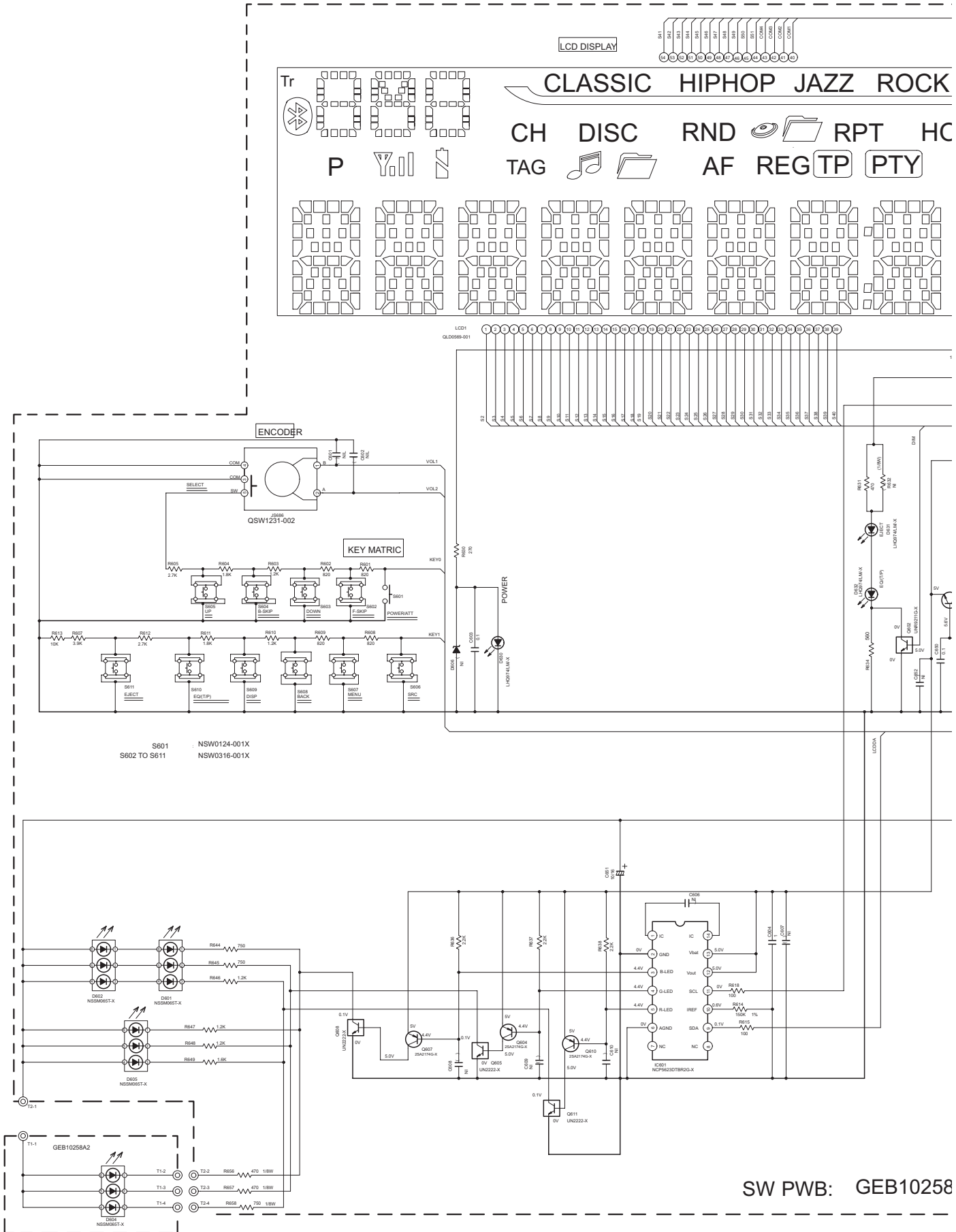

Z ROCK POPS USER EQ

RPT HOLD HD LOUD
P PTY STMO

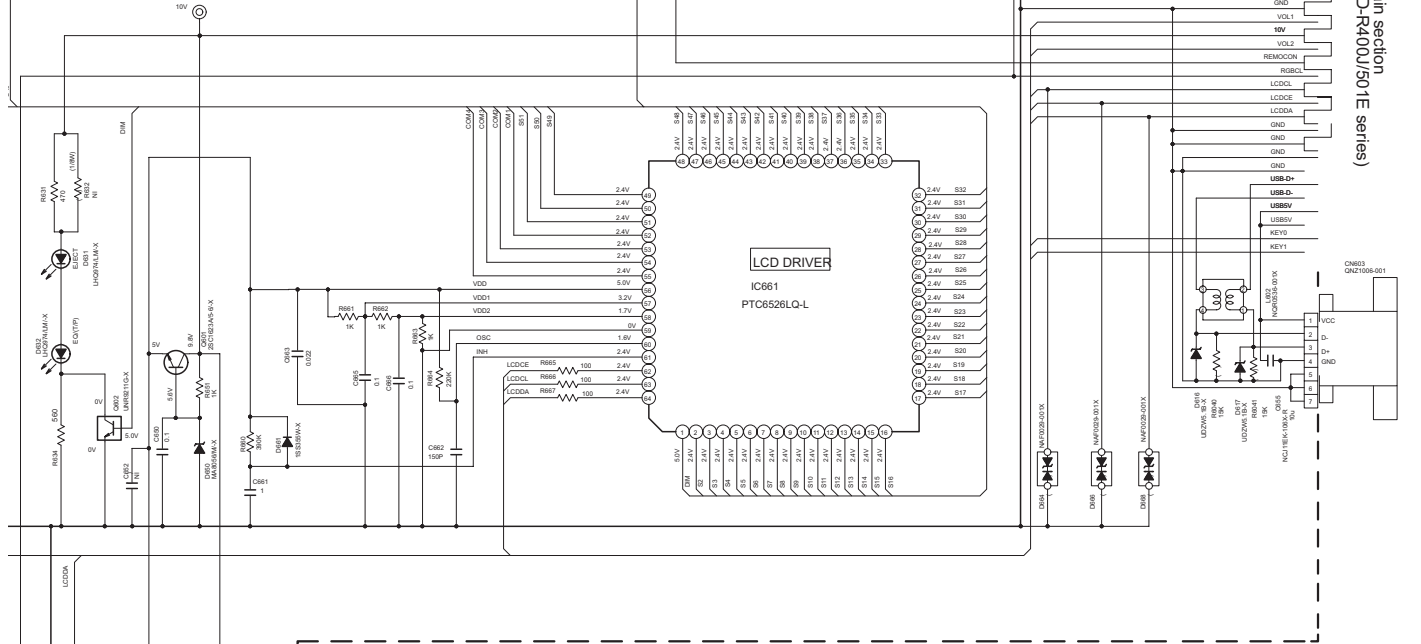
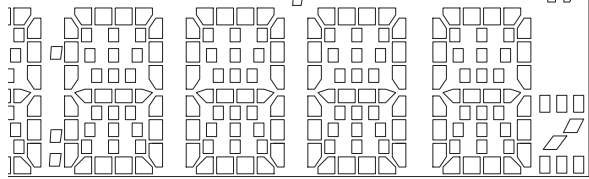

	4.7K		UN222-X
	4.7K		
	10K		UNR211G-X
	10K		

- NOTES
- VOLTAGES ARE DC-MEASURED WITH A DIGITAL VOLT METER WITHOUT INPUT SIGNAL.
 - UNLESS OTHERWISE SPECIFIED, ALL RESISTORS ARE 1/16W +5% METAL GLAZE RESISTOR. ALL CAPACITORS ARE 50V OR 25V CERAMIC CAPACITOR. ALL RESISTANCE VALUES ARE IN OHM. ALL CAPACITANCE VALUES ARE IN uF (P=pF) ALL E-CAPACITORS ARE SHOWN IN THE FORM OF CAPACITANCE(uF/RATED VOLTAGE(V)) T -- TANTALUM CAPACITOR.
 - COMPONENTS IN () INDICATE NOT USE.

GEB10258A1

Main section (Except KD-R400J/501E series)

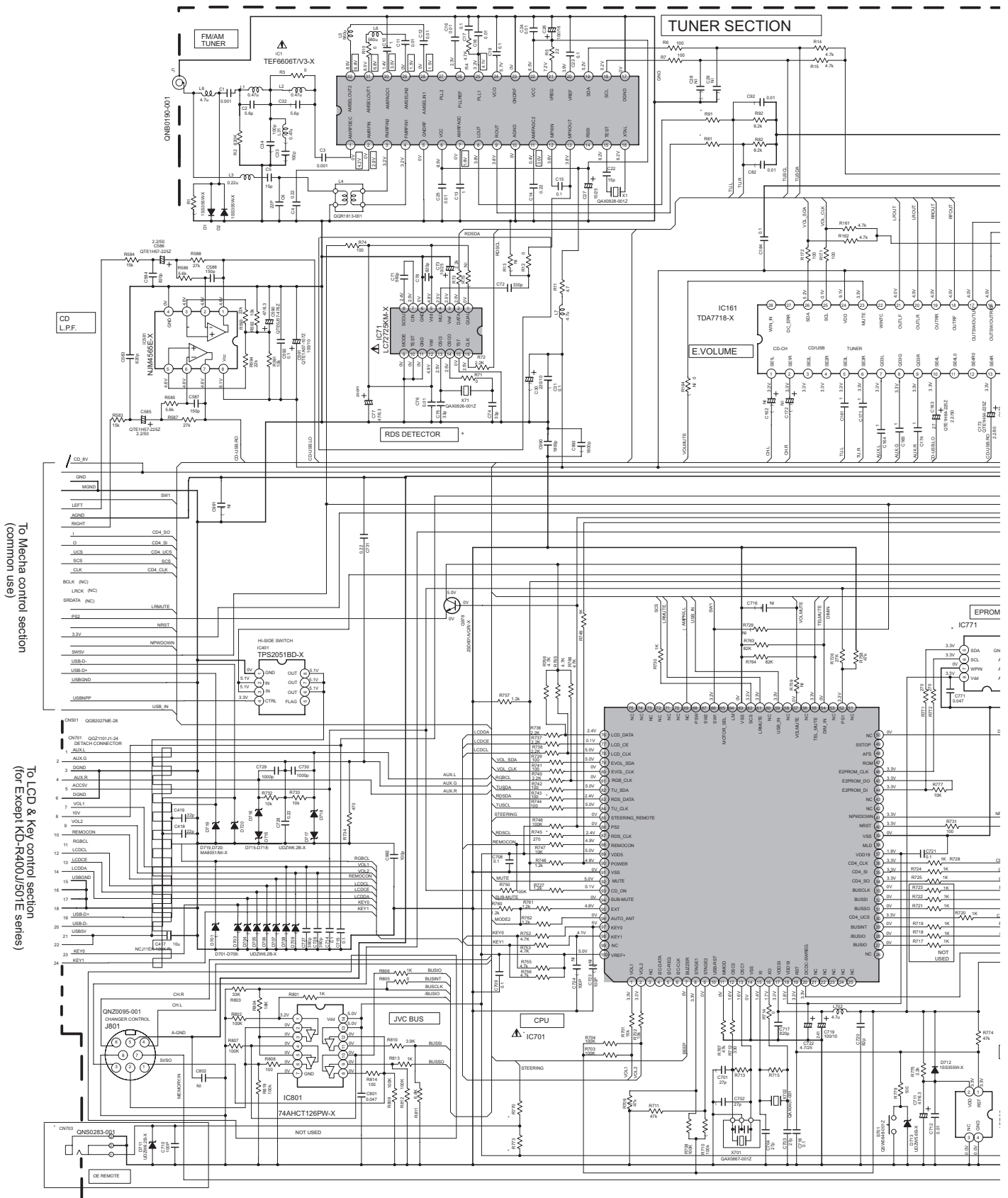

To Mecha control section
(common use)

To LCD & Key control section
(for Except KD-R400J/501E series)

- NOTES**
1. VOLTAGES ARE DC-MEASURED WITH A DIGITAL VOLT METER WITHOUT INPUT SIGNAL CONDITION—FM MODE. AM MODE  MODE.
 2. UNLESS OTHERWISE SPECIFIED, ALL RESISTORS ARE 1/16W 5% METAL GLAZE RESISTOR. ALL CAPACITORS ARE 50V OR 25V CERAMIC CAPACITOR. ALL RESISTANCE VALUES ARE IN OHM. ALL CAPACITANCE VALUES ARE IN uF(P=HPF) ALL E CAPACITORS ARE SHOWN IN THE FORM OF CAPACITANCE(uF)/RATED VOLTAGE(V) COMPONENTS IN (j) INDICATE NOT USE.

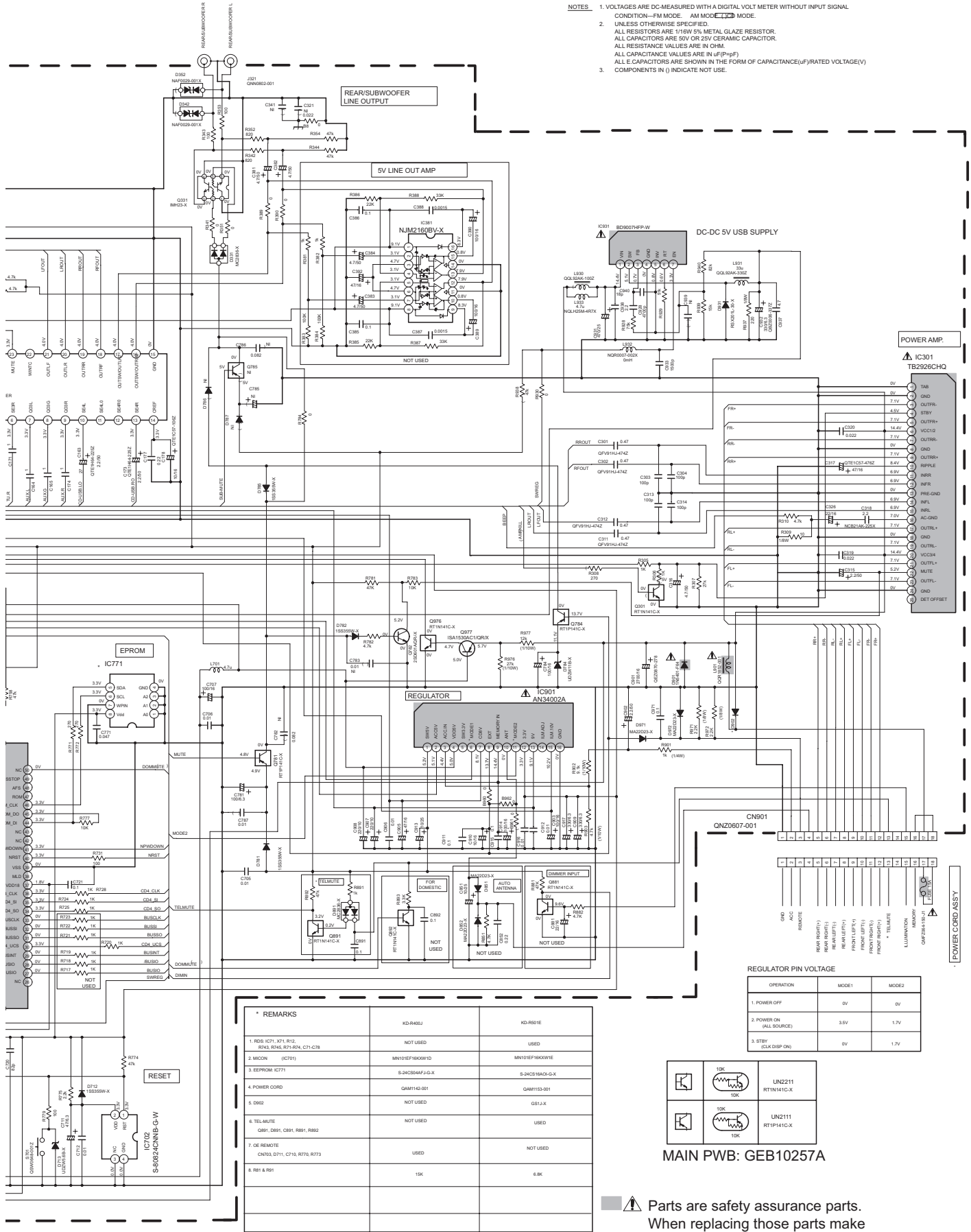

*** REMARKS**

	KD-R50J	KD-R50E
1. RDS (IC71, X71, R12, R24, R34, R70, R74, C71, C78)	NOT USED	USED
2. MICON (IC70)	MN12EF7600V1D	MN12EF7600V1E
3. EEPROM (IC771)	S-24C25AN-F-G-X	S-24C257AC-G-X
4. POWER CORD	QAM1142-001	QAM1153-001
5. DWR2	NOT USED	QST1J-X
6. TELMUTE (Q81, D81, C81, R81, R82)	NOT USED	USED
7. OE REMOTE (CN70, D71, C71, R75, R77)	USED	NOT USED
8. R81 & R91	15K	6.8K

REGULATOR PIN VOLTAGE

OPERATION	MODE:1	MODE:2
1. POWER OFF	0V	0V
2. POWER ON (ALL SOURCE)	3.5V	1.7V
3. STBY (CLK DISP ON)	0V	1.7V

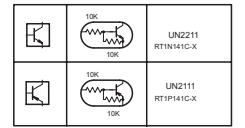

MAIN PWB: GE10257A

 Parts are safety assurance parts. When replacing those parts make sure to use the specified one.

LCD & Key control section (Except KD-R400J/501E series)

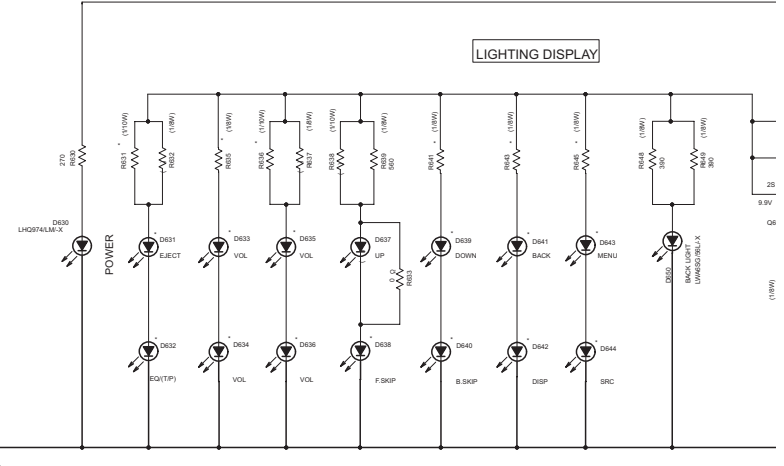
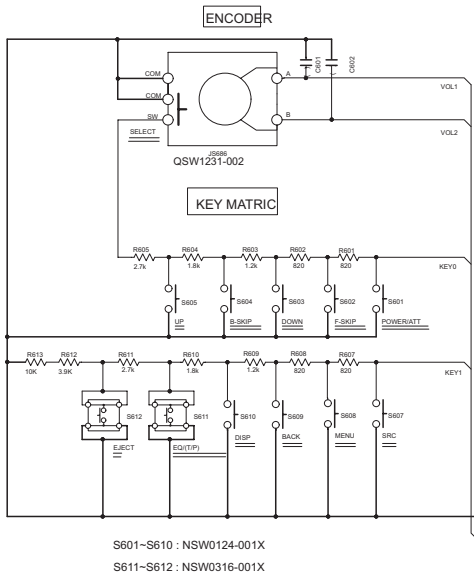
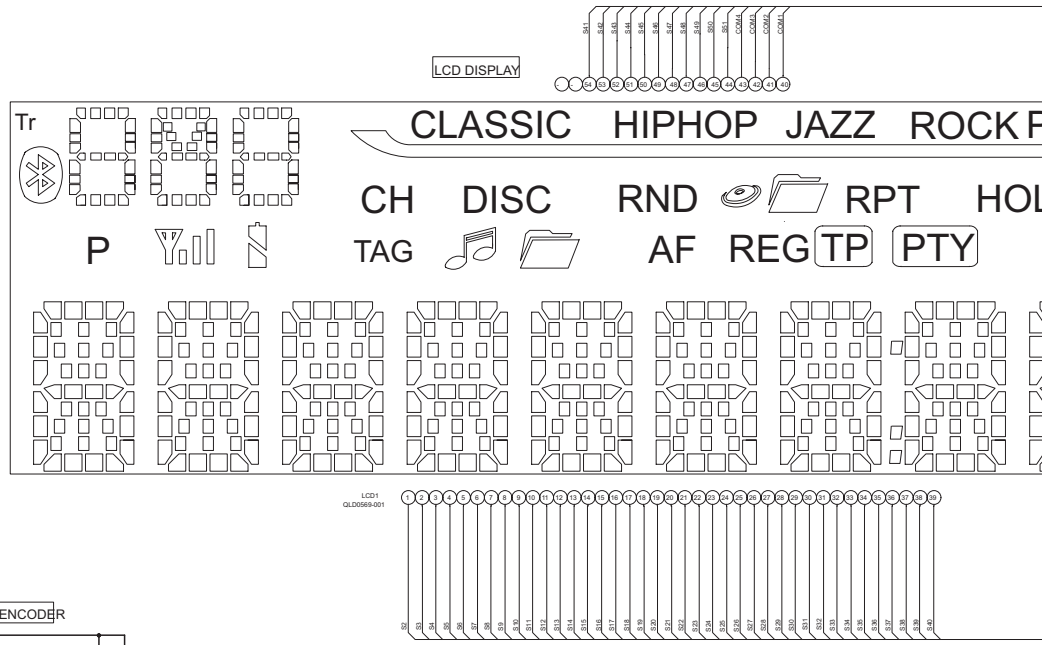

S601-S610 : NSW0124-001X
 S611-S612 : NSW0316-001X

SWPWB: GEB10259A

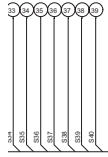
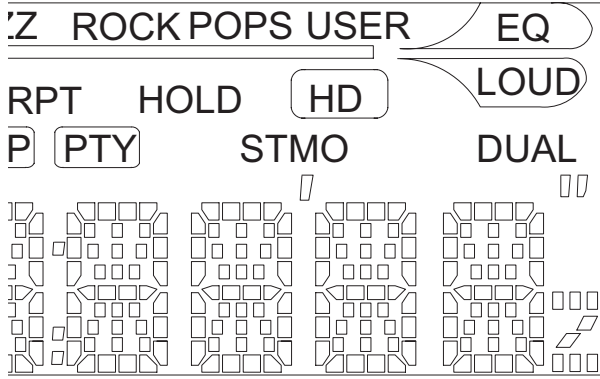

AY

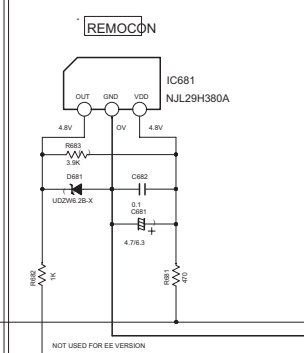
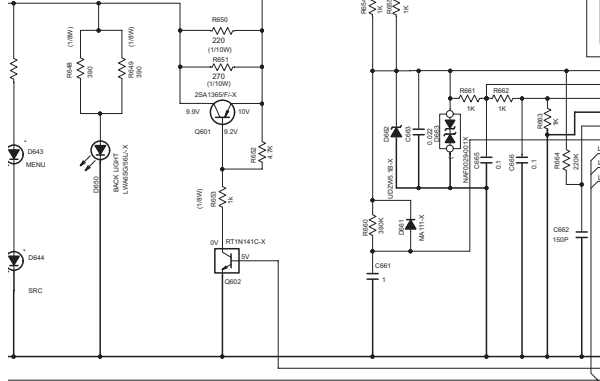

NOT USED FOR EE VERSION

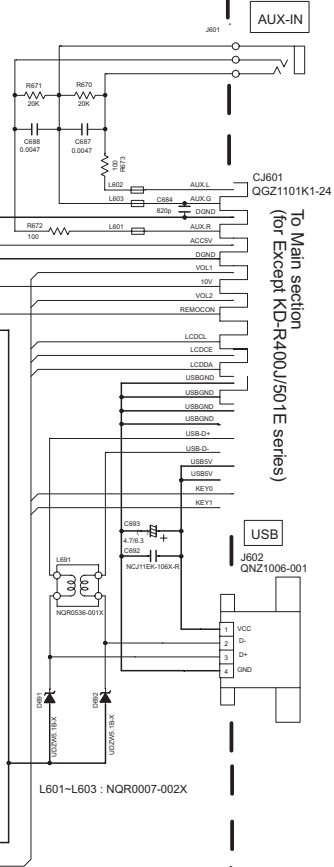
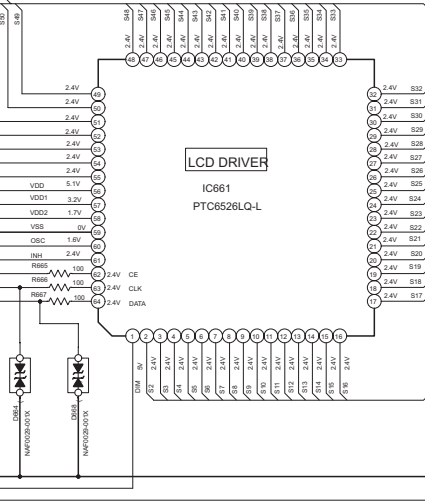

To Main section
(for Except KD-R400J/501E series)

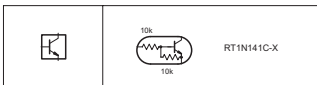

NOTES
1. VOLTAGES ARE DC-MEASURED WITH A DIGITAL VOLT METER WITHOUT INPUT SIGNAL

2. UNLESS OTHERWISE SPECIFIED.
ALL RESISTORS ARE 1/16W +5% METAL GLAZE RESISTOR.
ALL CAPACITORS ARE 50V OR 25V CERAMIC CAPACITOR.
ALL RESISTANCE VALUES ARE IN OHM.
ALL CAPACITANCE VALUES ARE IN uF(P=PF)
ALL CAPACITORS ARE SHOWN IN THE FORM OF CAPACITANCE(uF)/RATED VOLTAGE(V)
T — TANTALUM CAPACITOR.

3. COMPONENTS IN () INDICATE NOT USE.

REMARKS		KD-R407EE	KD-R401E SERIES KD-R402EY	KD-R504UJ KD-R505UJ SERIES KD-R506UJ SERIES KD-R508UF
LED	D631-D636 D638-D644	LSQ971MLJ-X	LSQ971MLJ-X	LHQ274LM-X
LED BRIGHTNESS	R631, R635	430	430	470
	R636	430	430	470
	R641, R643	510	510	560
	R645	510	510	560
AUX JACK	J601	ONS9279-001	ONS9279-001	ONS9285-001
REMOTE		NOT USED	USED	USED

Mecha control section (common use)

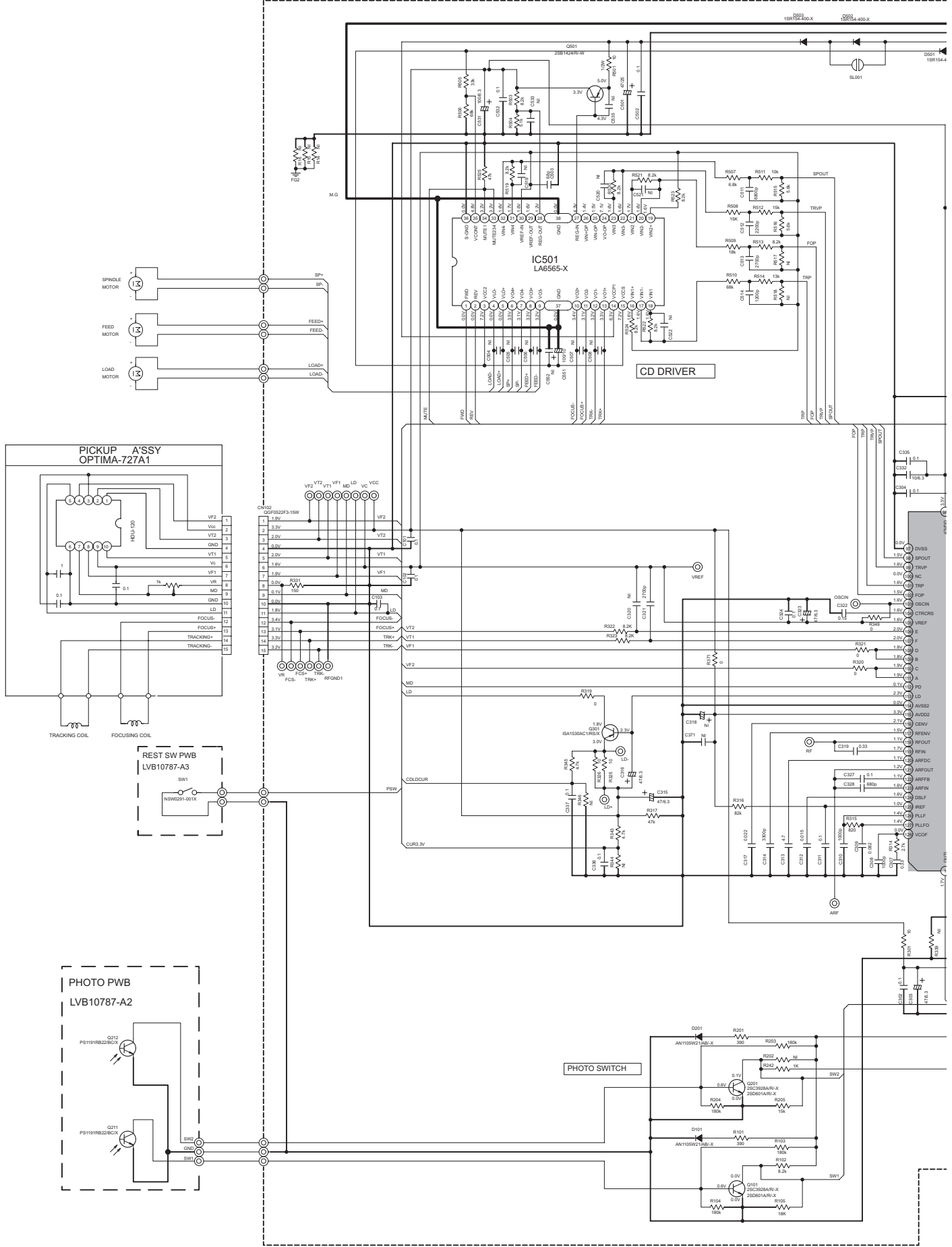

To Main section
(for KD-R400J/501E series)

To Main section
(for Except KD-R400J/501E series)

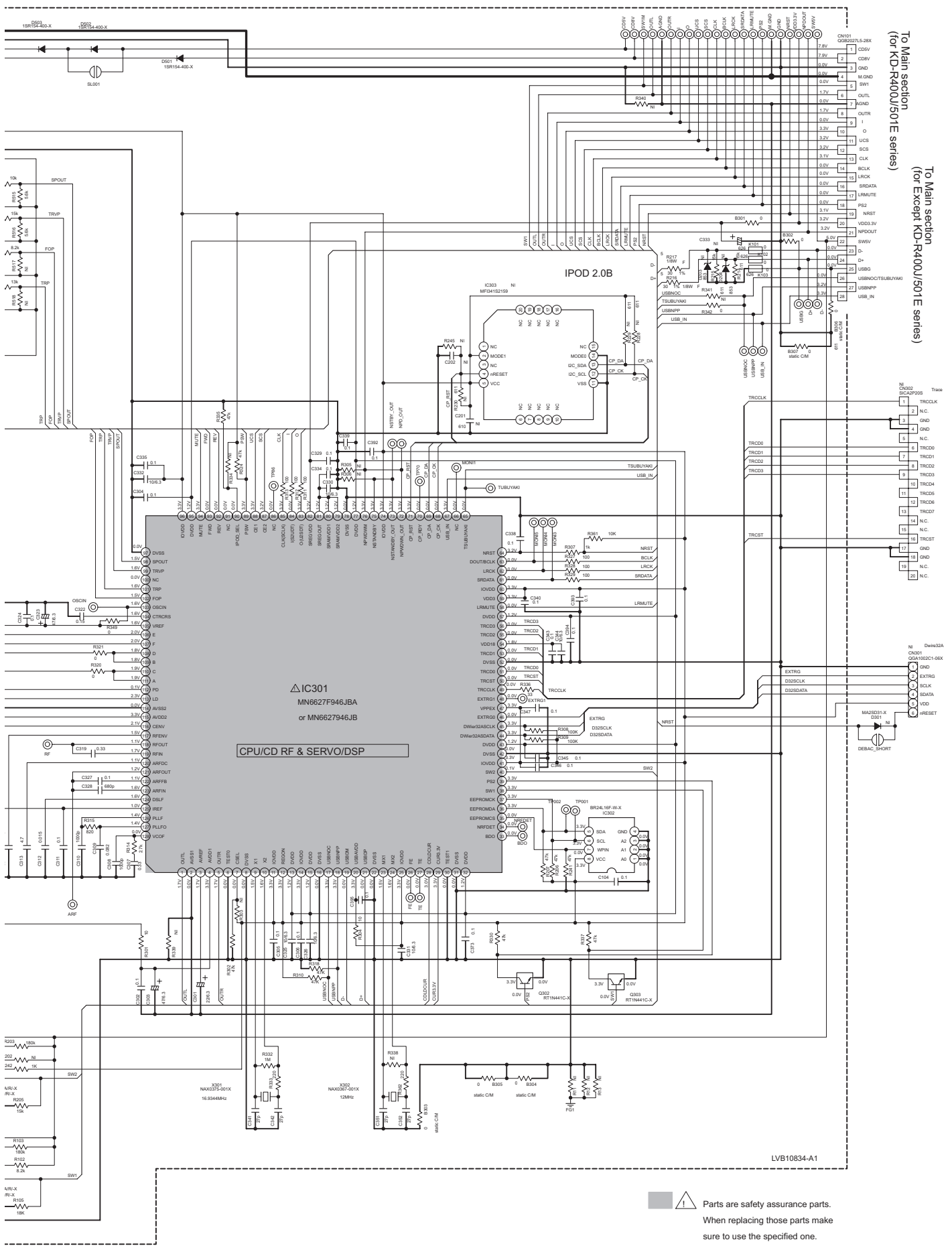

Parts are safety assurance parts.
When replacing those parts make
sure to use the specified one.

Printed circuit boards

■ Main Board (for KD-R400J/501E series)

Lead free solder used in the board (material : Sn-Ag-Cu, melting point : 219 Centigrade)

Lead free solder used in the board (material : Sn-Cu, melting point : 230 Centigrade)

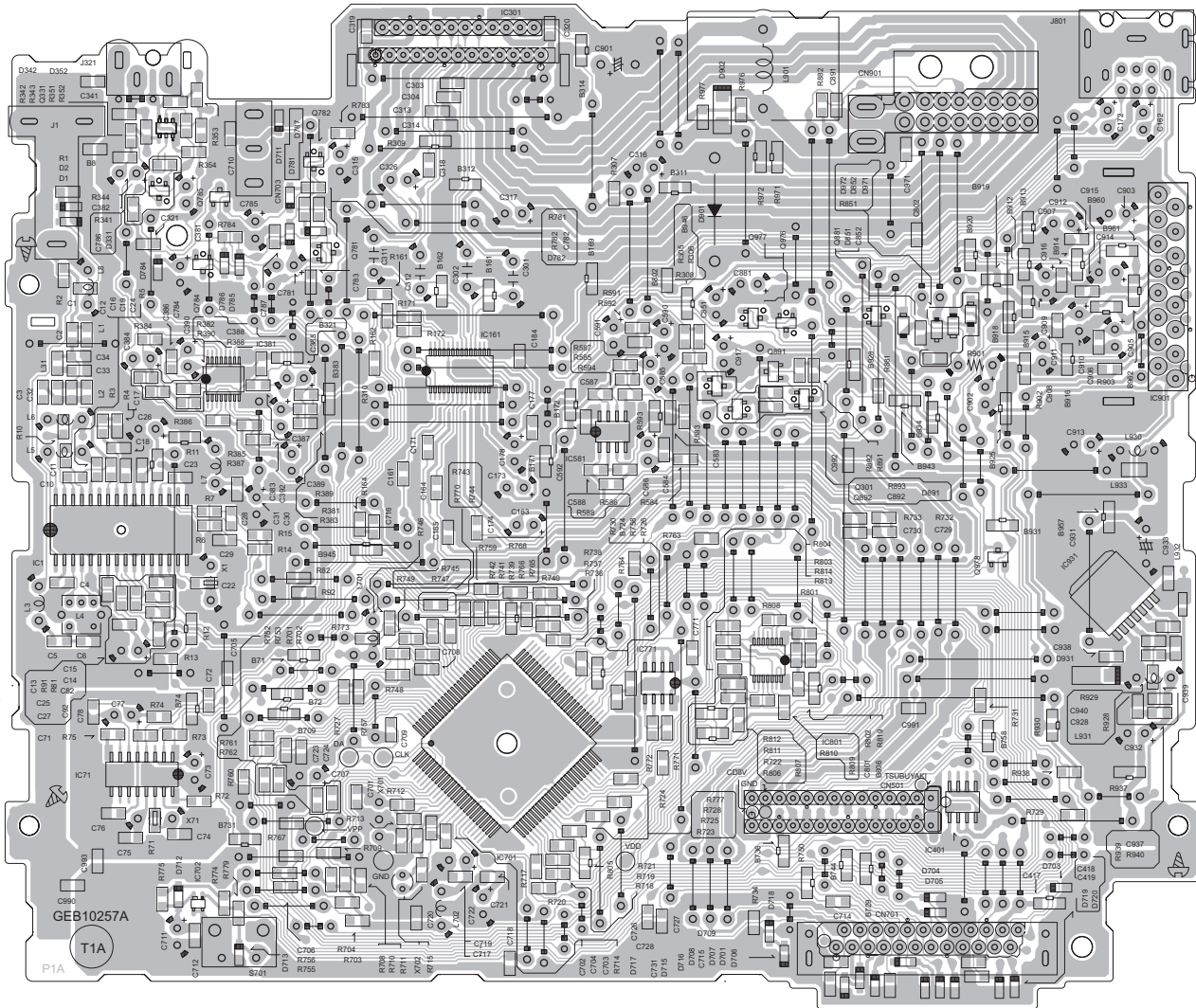

■ Photo board (common use)

Lead free solder used in the board (material : Sn-Ag-Cu, melting point : 219 Centigrade)

Lead free solder used in the board (material : Sn-Cu, melting point : 230 Centigrade)

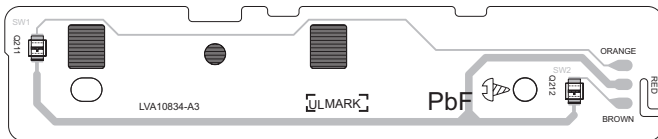

■ Reset board (common use)

Lead free solder used in the board (material : Sn-Ag-Cu, melting point : 219 Centigrade)

Lead free solder used in the board (material : Sn-Cu, melting point : 230 Centigrade)

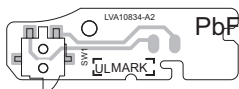

■ Main Board (Except KD-R400J/501E series)

Lead free solder used in the board (material : Sn-Ag-Cu, melting point : 219 Centigrade)

Lead free solder used in the board (material : Sn-Cu, melting point : 230 Centigrade)

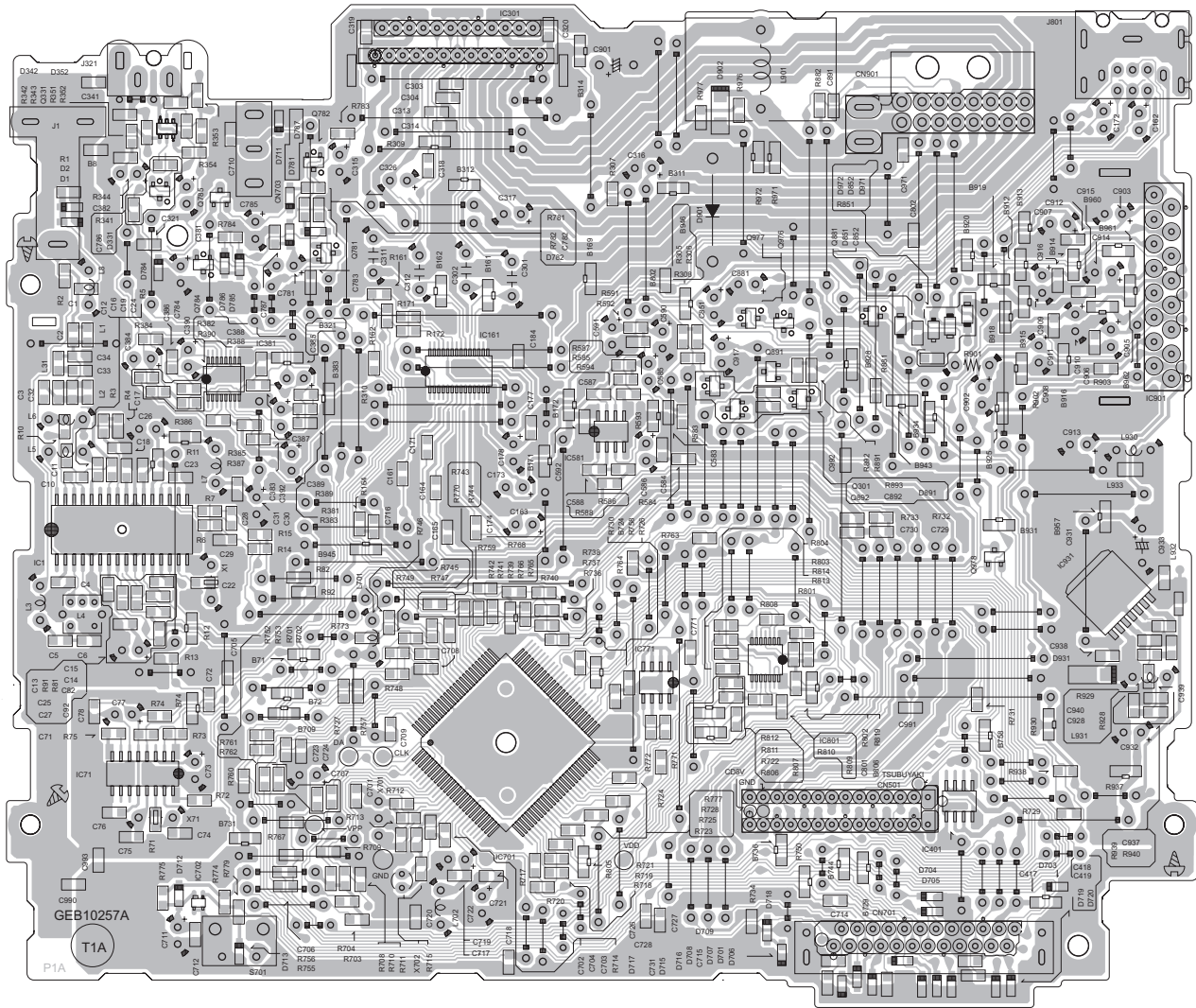

■ LED board (for KD-R400J/501E series)

Lead free solder used in the board (material : Sn-Ag-Cu, melting point : 219 Centigrade)

Lead free solder used in the board (material : Sn-Cu, melting point : 230 Centigrade)

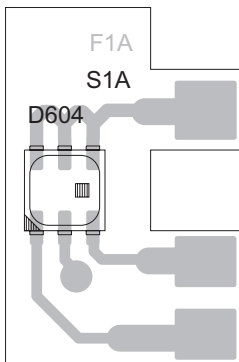

forward side

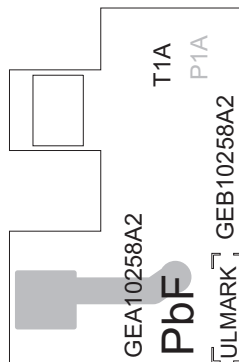

reverse side

Switch board

Lead free solder used in the board (material : Sn-Ag-Cu, melting point : 219 Centigrade)

Lead free solder used in the board (material : Sn-Cu, melting point : 230 Centigrade)

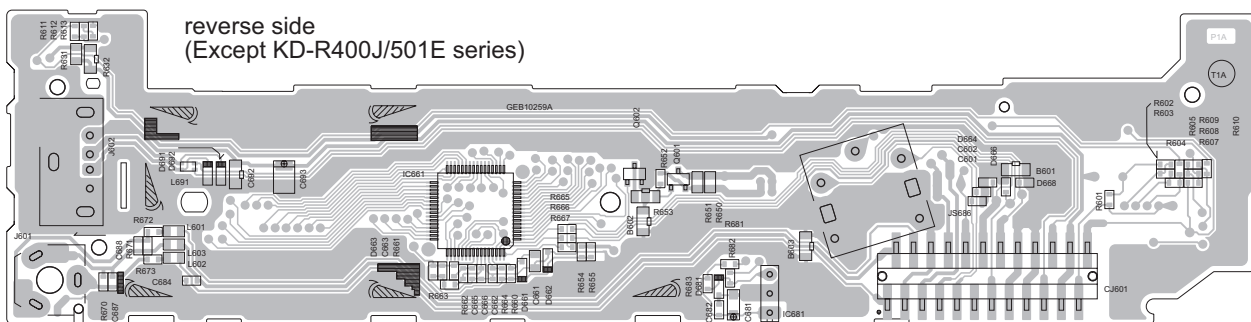
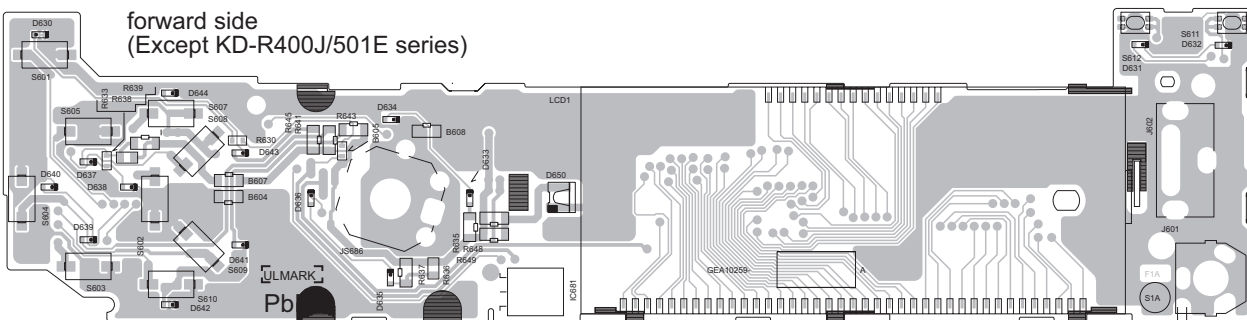
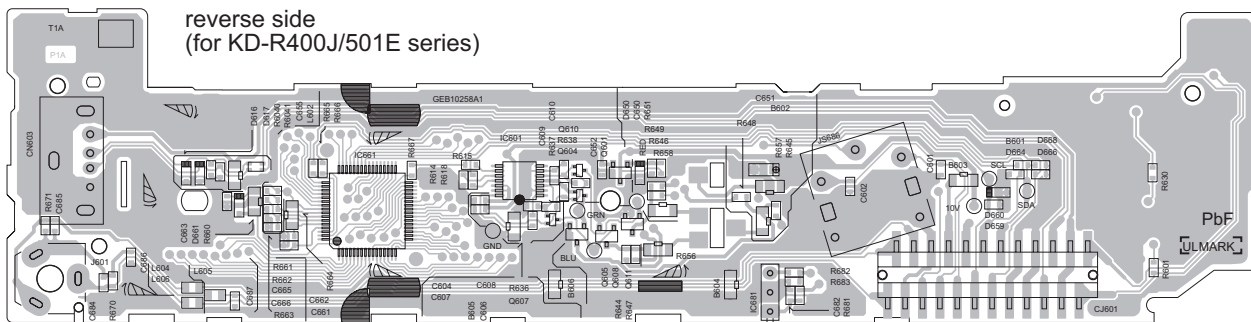
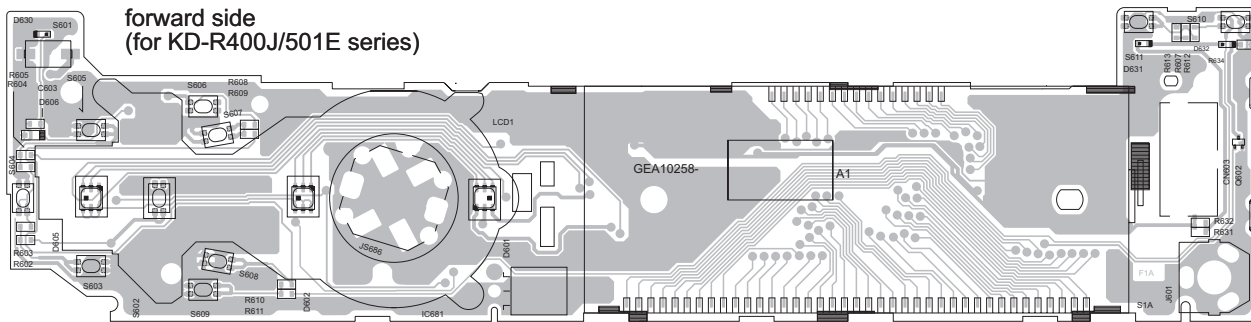

■ Mecha board (common use)

Lead free solder used in the board (material : Sn-Ag-Cu, melting point : 219 Centigrade)

Lead free solder used in the board (material : Sn-Cu, melting point : 230 Centigrade)

forward side

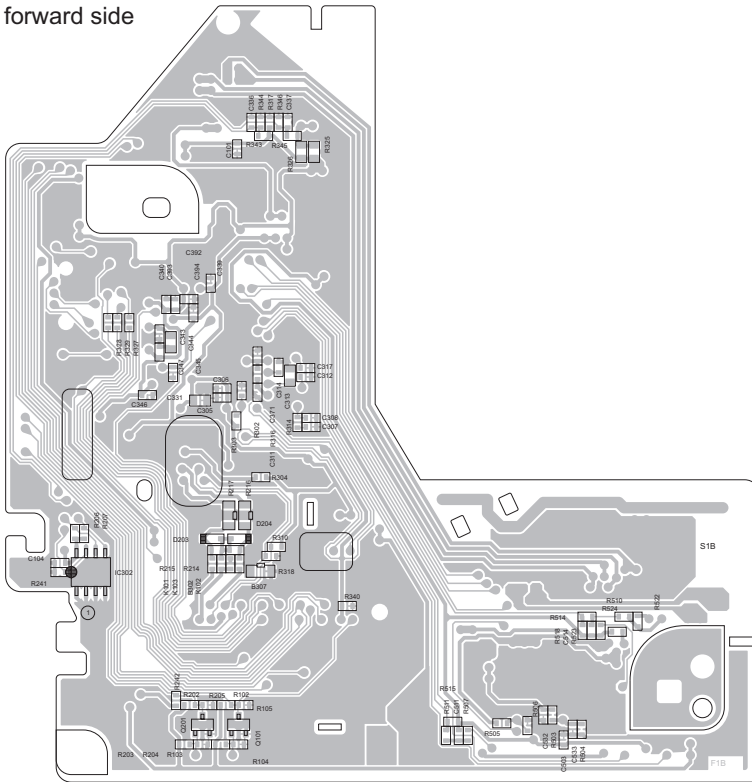

reverse side

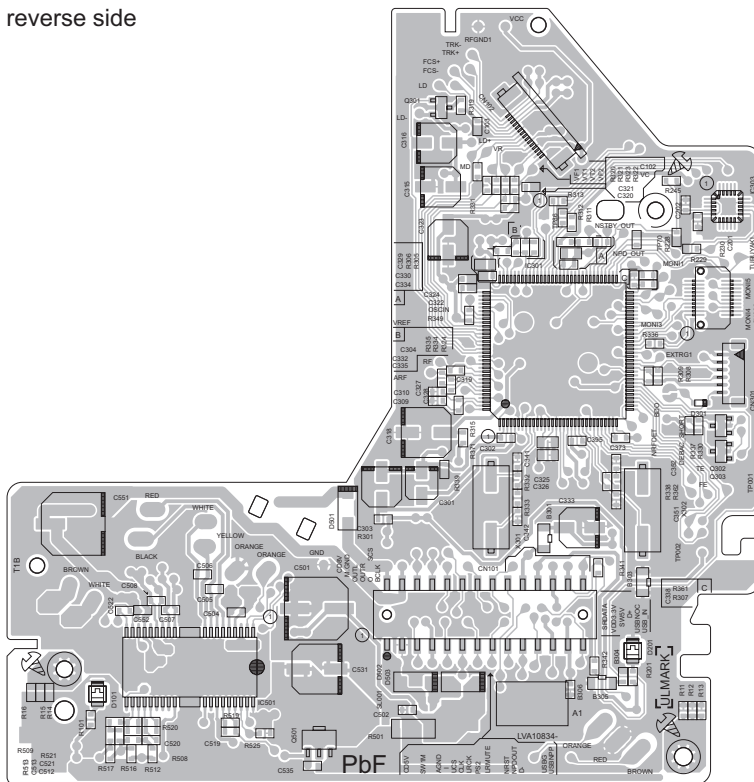



Victor Company of Japan, Limited

Mobile Entertainment Division 10-1,1chome,Ohwatari-machi,Maebashi-city,Gumma-ken,371-8543,Japan

Free Manuals Download Website

<http://myh66.com>

<http://usermanuals.us>

<http://www.somanuals.com>

<http://www.4manuals.cc>

<http://www.manual-lib.com>

<http://www.404manual.com>

<http://www.luxmanual.com>

<http://aubethermostatmanual.com>

Golf course search by state

<http://golfingnear.com>

Email search by domain

<http://emailbydomain.com>

Auto manuals search

<http://auto.somanuals.com>

TV manuals search

<http://tv.somanuals.com>