

JVC



ENGLISH

ESPAÑOL

FRANÇAIS

KW-R800BT

CD RECEIVER / RECEPTOR CON CD / RÉCEPTEUR CD

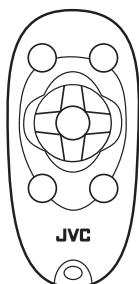

WMA

MP3

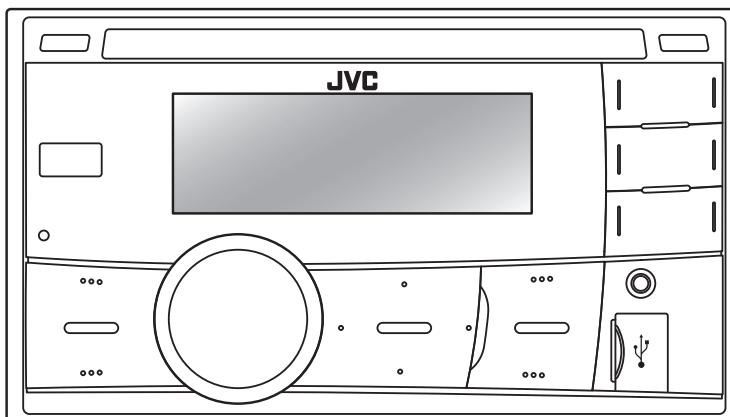

For canceling the display demonstration, see page 4. /
Para cancelar la demostración en pantalla, consulte la página 4. /
Pour annuler la démonstration des affichages, référez-vous à la page 4.

For installation and connections, refer to the separate manual.
Para la instalación y las conexiones, refiérase al manual separado.
Pour l'installation et les raccordements, se référer au manuel séparé.

For Customer Use:
Enter below the Model No. and Serial No. which are located on the top or bottom of the cabinet. Retain this information for future reference.
Model No. _____
Serial No. _____



**INSTRUCTIONS
MANUAL DE INSTRUCCIONES
MANUEL D'INSTRUCTIONS**

Thank you for purchasing a JVC product.

Please read all instructions carefully before operation, to ensure your complete understanding and to obtain the best possible performance from the unit.

For U.S.A.

This equipment has been tested and found to comply with the limits for a Class B digital device, pursuant to Part 15 of the FCC Rules. These limits are designed to provide reasonable protection against harmful interference in a residential installation. This equipment generates, uses, and can radiate radio frequency energy and, if not installed and used in accordance with the instructions, may cause harmful interference to radio communications. However, there is no guarantee that interference will not occur in a particular installation. If this equipment does cause harmful interference to radio or television reception, which can be determined by turning the equipment off and on, the user is encouraged to try to correct the interference by one or more of the following measures:

- Reorient or relocate the receiving antenna.
- Increase the separation between the equipment and receiver.
- Connect the equipment into an outlet on a circuit different from that to which the receiver is connected.
- Consult the dealer or an experienced radio/TV technician for help.

Caution:

Changes or modifications not expressly approved by the party responsible for compliance could void the user's authority to operate the equipment.

Use of controls or adjustments or performance of procedures other than those specified herein may result in hazardous radiation exposure. In compliance with Federal Regulations, following are reproductions of labels on, or inside the product relating to laser product safety.

JVC KENWOOD Corporation
2967-3, ISHIKAWA-MACHI,
HACHIOJI-SHI, TOKYO, JAPAN

THIS PRODUCT COMPLIES WITH DHHS
RULES 21CFR SUBCHAPTER J IN EFFECT AT
DATE OF MANUFACTURE.

Location: Bottom Plate

IMPORTANT FOR LASER PRODUCTS

1. CLASS 1 LASER PRODUCT
2. **CAUTION:** Do not open the top cover. There are no user serviceable parts inside the unit; leave all servicing to qualified service personnel.
3. **CAUTION:** (For U.S.A.) Visible and/or invisible class II laser radiation when open. Do not stare into beam.
(For Canada) Visible and/or invisible class 1M laser radiation when open. Do not view directly with optical instruments.
4. REPRODUCTION OF LABEL: CAUTION LABEL, PLACED OUTSIDE THE UNIT.

CAUTION VISIBLE AND/OR INVISIBLE CLASS 1M LASER RADIATION WHEN OPEN. DO NOT VIEW DIRECTLY WITH OPTICAL INSTRUMENTS. IEC60825-1:2001 (ENG)	ATTENTION RAYONNEMENT LASER VISIBLE ET/OU INVISIBLE DE CLASSE 1M UNE FOIS OUVERT. NE PAS REGARDER DIRECTEMENT AVEC DES INSTRUMENTS OPTIQUES. (FRA)	AVISO RADIACIÓN LÁSER DE CLASE 1M VISIBLE Y/O INVISIBLE CUANDO ESTÁ ABIERTO. NO MIRAR DIRECTAMENTE CON INSTRUMENTAL ÓPTICO. (ESP)	VARNING SYNLIG OCH/ELLER OSYNLIG LASERSTRÅLNING, KLASS 1M, NÅR DENNA DEL ÄR ÖPPNAD. BETRÄKTA EJ STRÅLEN MED OPTISKA INSTRUMENT. (SWE)	注意 ここを開くと可視 及び/または不可視 のクラス1M レーザー放射が 出ます。 光学装置で直接 見ないでください。 (JPN)	CAUTION VISIBLE AND/OR INVISIBLE CLASS II LASER RADIATION WHEN OPEN. DO NOT STARE INTO BEAM. FDA 21 CFR (ENG)
--	---	--	--	---	--



[European Union only]

Warning:

Stop the car before operating the unit.

Caution:

Adjust the volume so that you can hear sounds outside the car. Driving with the volume too high may cause an accident.

Avoid using the USB device or iPod/iPhone if it might hinder driving safety.

Caution on volume setting:

Digital devices (CD/USB) produce very little noise compared with other sources. Lower the volume before playing these digital sources to avoid damaging the speakers by the sudden increase of the output level.

Temperature inside the car:

If you have parked the car for a long time in hot or cold weather, wait until the temperature in the car becomes normal before operating the unit.

Condensation:

When the car is air-conditioned, moisture may collect on the laser lens. This may cause disc read errors. In this case, remove the disc and wait for the moisture to evaporate.

How to reset your unit

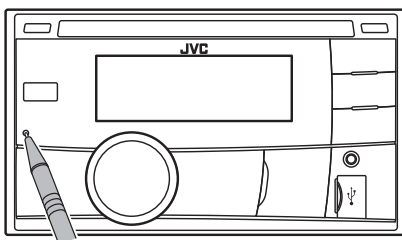

Your preset adjustments will also be erased.

How to forcibly eject a disc



- Be careful not to drop the disc when it ejects.
- If this does not work, reset your unit.

Contents

Preparation	4
Canceling the display demonstration	
Setting the clock	
Basic operations	4
Radio	6
HD Radio™ tuner control	8
Satellite Radio tuner control	9
CD/USB	10
iPod/iPhone	11
Quick Search	13
External components	13
Bluetooth® connection	14
Bluetooth mobile phone	16
Bluetooth audio player	20
Illumination color adjustments	21
Brightness adjustments	22
Sound adjustments	22
Menu operations	23
Remote controller	26
Additional information	26
Troubleshooting	29
Specifications	32

How to read this manual:

- This manual mainly explains operations using the buttons on the control panel.
- < > indicates the displays on the control panel.
- [XX] indicates the initial setting of a menu item.

Maintenance







Cleaning the unit

Wipe off the dirt on the panel with a dry silicon or soft cloth. Failure to observe this precaution may result in damage to the unit.













Preparation

Canceling the display demonstration

The display demonstration is always turned on unless you cancel it.



- 1  (Hold) 
- 2  
- 3 Select <DEMO OFF>.   → 
- 4 Press **MENU** to exit.

Setting the clock

- 1  (Hold) 
- 2 Select <CLOCK>.   → 
- 3 Select <CLOCK SET>.  → 
- 4 Adjust the hour.   → 
- 5 Adjust the minute.   → 
- 6 Press **MENU** to exit.

Basic operations

Display information

-  Changes the display information. (Press)
 Scrolls the current display information. (Hold)

Source	Display
Radio	Non-Radio Broadcast Data System station: Frequency ↔ Clock FM Radio Broadcast Data System station: Station name (PS) → Frequency → Program type (PTY) → Clock → (back to the beginning)
HD Radio	Call Sign*1 → Frequency → Title/artist/album name of the current segment*2 → Clock → (back to the beginning)
Satellite Radio	Category name → Channel name → Artist name → Composer name*3 → Song/program name/title → Clock → (back to the beginning)
CD/USB/Bluetooth Audio	Album title/Artist* → Track title* → Track no./Playing time → Track no./Clock → (back to the beginning)
iPod/iPhone (HEAD MODE/ IPOD MODE)	* "NO NAME" appears for conventional CDs or if not recorded.
iPod/iPhone (APP MODE)	APP MODE ↔ Clock
iPod/iPhone (Pandora® internet radio)	Station name → Album title/Artist → Track title → Playing time → Clock → (back to the beginning)
External Components	EXT INPUT or AUX IN ↔ Clock

*1 "****-FM" or "*****" appears when no Call Sign is received.

*2 "NO TEXT" appears when no text is received.

*3 Only for SIRIUS Satellite Radio.

Control panel

Remote controller

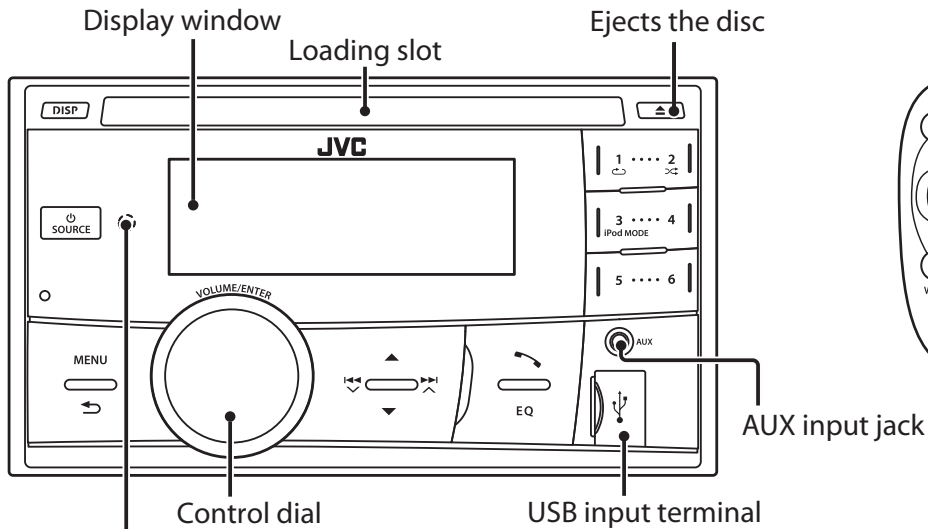

- Remote sensor
- Aim the remote controller directly at the sensor.
 - DO NOT expose to bright sunlight.

When you press or hold the following button(s)...

Control panel	Remote controller	General function
<p>SOURCE</p>	—	<ul style="list-style-type: none"> • Turns on. • Turns off. (Hold) • Press the SOURCE button on the control panel and turn the control dial within 2 seconds to select the source.
	SOURCE	Press repeatedly to select the source.
Control dial (turn)	VOL - / +	Adjusts the volume level.
	—	Selects items.
Control dial (press)		<ul style="list-style-type: none"> • Mutes the sound or pauses playback. • Press the button again to cancel muting or resume playback.
	—	Confirms selection.
Number buttons (1 - 6)	—	<ul style="list-style-type: none"> • Selects the preset stations. • Stores the current station into the selected number button. (Hold) (see page 6)
EQ	SOUND	Selects the preset sound mode. (see page 22)
	—	<ul style="list-style-type: none"> • Enters “Hands-Free” menu (see page 17), or answers incoming call when the unit rings. • Ends a call. (Hold)
	—	Returns to the previous menu.
		<ul style="list-style-type: none"> • Selects a preset station (see page 6)/category (see page 9). • Searches for HD Radio stations only. (Hold) • Searches for HD Radio multicast channels. • Selects MP3/WMA/WAV folder. (see page 10)
		<ul style="list-style-type: none"> • Searches for a station automatically. (see page 6) • Searches for a station manually. (Hold) • Selects track (see page 10, 11, 20)/Satellite Radio channel. • Fast-forwards or reverses track. / Changes Satellite Radio channel rapidly. (Hold)

Radio

Searching for a station

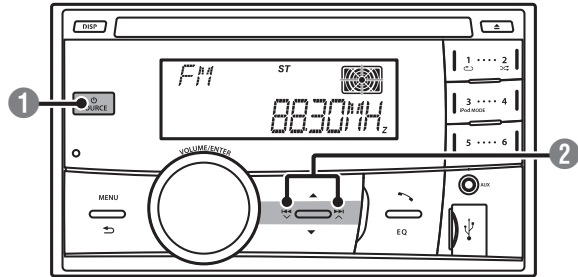

- 1 Select <FM> or <AM>.
- 2 Auto search. (Press)
Manual search. (Hold)
"M" flashes, then press the button repeatedly.

"ST" lights up when receiving an FM stereo broadcast with sufficient signal strength.

Storing stations in memory

Manual presetting

You can preset up to 18 stations for FM and 6 stations for AM.

While listening to a station...

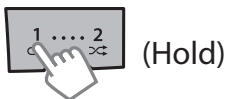

The preset number flashes and "MEMORY" appears. The current station is stored to the selected number button (1 - 6).

----- or -----



"PRESET MODE" flashes.

2 Select preset number.

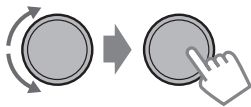

The preset number flashes and "MEMORY" appears.

Auto presetting (FM)

SSM (Strong-station Sequential Memory)

You can preset up to 18 stations for FM.

- If an HD Radio tuner box is connected, you can also preset up to 6 stations for AM.



"SSM" flashes. When all the stations are stored, "SSM" stops flashing.

To preset <SSM 07 - 12>/<SSM 13 - 18>, repeat steps 1 and 2.

Selecting a preset station

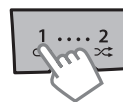

----- or -----

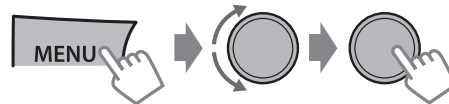

You can also select a preset station using ▲/▼.

Setting the Radio Timer

You can tune in to a preset station at a specific time regardless of the current source.

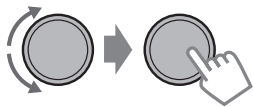
- 1  (Hold)
- 2 
 - ➔ <TUNER>
 - ➔ <RADIO TIMER>
 - ➔ <OFF>/<ONCE>/<DAILY>

[OFF]	Cancels Radio Timer.
ONCE	Activates once.
DAILY	Activates daily.

- 3 **Select the preset station.**
 - ➔ <FM>/<AM>
 - ➔ <01> ... <18> for FM/
<01> ... <06> for AM

- 4 **Set the activation time.**

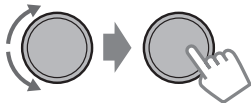

- 5 **Press MENU to exit.**

- ⌚ lights up after the Radio Timer has been set.
- Only one timer can be set. Setting a new timer will override the previous setting.
- The Radio Timer will not activate if the unit is turned off or if <AM> is set to <OFF> after selecting an AM station for the timer.

Searching for your favorite Programs—Program Type (PTY) Search

This feature is only available for FM Radio Broadcast Data System stations.

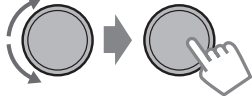
- 1  (Hold)
- 2 **Select a PTY code.**
 - ➔ 

PTY Search starts.

If there is a station broadcasting a program of the same PTY code as you have selected, that station is tuned in.

PTY codes

NEWS, INFORM (information), SPORTS, TALK, ROCK, CLS ROCK (classic rock), ADLT HIT (adult hits), SOFT RCK (soft rock), TOP 40, COUNTRY, OLDIES, SOFT, NOSTALGA (nostalgia), JAZZ, CLASSICL (classical), R & B (rhythm and blues), SOFT R & B (soft rhythm and blues), LANGUAGE, REL MUSC (religious music), REL TALK (religious talk), PERSNLTY (personality), PUBLIC, COLLEGE, HABL ESP (spanish talk), MUSC ESP (spanish music), HIP HOP, WEATHER

HD Radio™ tuner control

This unit can control the JVC KT-HD300 HD Radio tuner box (separately purchased). Refer to the KT-HD300 instruction manual for installation and connection details.

- HD Radio tuners can also tune in to conventional analog broadcasts.
- Many HD Radio stations offer more than one channel of programming. This service is called multicasting.
- To find HD Radio stations in your area, visit <<http://www.hdradio.com/>>.

Searching for a station

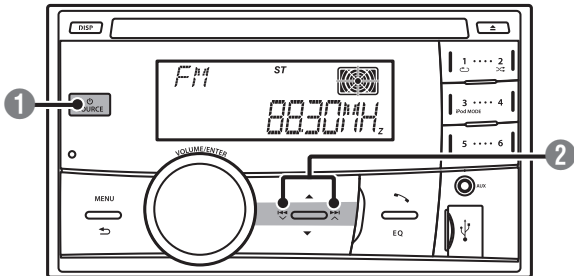

- 1 Select <HD RADIO FM> or <HD RADIO AM>.
- 2 Auto search. (Press)
Manual search. (Hold)
“M” flashes, then press the button repeatedly.

- HD Radio station: “HD” lights up when receiving digital audio, or flashes when receiving analog audio.
- Conventional FM station: “ST” lights up when receiving an FM stereo broadcast with sufficient signal strength.

Searching for HD Radio stations only

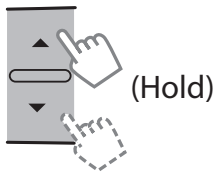

“HD” flashes when a station is tuned in, and searching stops.

Selecting an HD Radio multicast channel

When receiving HD Radio multicast channels...



Select your desired channel (HD1 to HD8).

“LINKING” appears while linking to a multicast channel.

Changing HD Radio reception mode

While receiving an HD Radio broadcast, you can change the reception mode—digital or analog.

- This setting does not take effect for the conventional FM/AM stations.



- 2 →<TUNER>
→<BLEND HOLD>
→<AUTO>/<ANALOG>/<DIGITAL>

[AUTO]	Switches between digital and analog audio automatically. “HOLD” flashes if the radio station forces only analog reception.
ANALOG	Tunes to analog audio only. “HOLD” lights up.
DIGITAL	Tunes to digital audio only. “HOLD” lights up.

The setting automatically returns to <AUTO> when you tune in to another broadcast.

- For storing stations in memory and selecting a preset station, page 6.

Satellite Radio tuner control

Before operating, connect either one of the following systems (not supplied) to the expansion port on the rear of this unit. Refer to the "Installation/Connection Manual" for details.

SIRIUS Satellite Radio	JVC KS-SRA100 (SIRIUS Satellite Radio interface) and <ul style="list-style-type: none"> • SCC1 (SiriusConnect Vehicle Tuner) or • SCVDOC1 (SiriusConnect Vehicle Docking Kit) and SIRIUS radio
XM Satellite Radio	<ul style="list-style-type: none"> • XMDJVC100 (Smart Digital Adapter for JVC) and XM Universal Tuner Box • CNPJVC1 (Connection cable for JVC) and CNP2000UCA (Protocol Interface Adapter and XM Direct 2 Tuner)

- For details, refer also to the instructions supplied with the other components.
- For SIRIUS/XM programming, visit <www.siriusxm.com>.

Activating your SIRIUS subscription

- 1 Select <SIRIUS>.



SIRIUS Satellite Radio starts updating the SIRIUS channels. Once completed, SIRIUS Satellite Radio tunes in to the Preview Channel.

- 2 Select "Channel 0" to check your SIRIUS ID.



The 12-digit SIRIUS ID will be displayed.

- You can also check your SIRIUS ID from the label on the packaging, or from menu operations (page 24).

- 3 Contact Sirius Satellite Radio on the internet at <www.siriusxm.com/activatenow> to activate your subscription, or call SIRIUS toll-free at 1-888-539-SIRIUS (7474).

Once subscription has been activated, "SUB UPDT PRESS ANY KEY" scrolls on the display.

Channel Updates (SIRIUS)

- If channels are updated after subscription, updating starts automatically. "UPDATING" flashes and no sound can be heard.
- Updates take a few minutes to complete.
- During an update, you cannot operate your Satellite Radio.

Activating your XM subscription

- 1 Select <XM>.



XMDirect2 Tuner System starts updating all the XM channels. "Channel 1" is tuned in automatically.

- 2 Select "Channel 0" to check your XM Satellite Radio ID.



The display alternates between "RADIO ID" and the 8-digit alphanumeric ID number.

- You can also check your XM Satellite Radio ID labeled on the casing of the XMDirect2 Tuner System.

- 3 Contact XM Satellite Radio on the internet at <www.siriusxm.com/activatenow> to activate your subscription, or call 1-800-XM-RADIO (1-800-967-2346).

Once subscription has been activated, the unit can be tuned to one of the available channels.

Selecting a channel

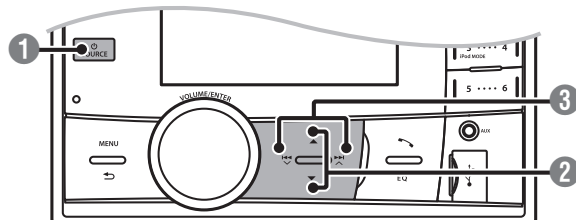

- 1 Select <SIRIUS> or <XM>.

- 2 Select a category.

If you want to select channels of all categories...

- SIRIUS: Select <ALL>.
- XM: Skip this step.

- 3 Select a desired channel.

Holding the button changes the channels rapidly. While searching, invalid and unsubscribed channels are skipped.

Storing channels in memory

You can preset up to 18 channels for both SIRIUS and XM.

("Manual presetting" page 6)

Selecting a preset station

("Selecting a preset station" page 6)

CD/USB

Playing a CD/USB device

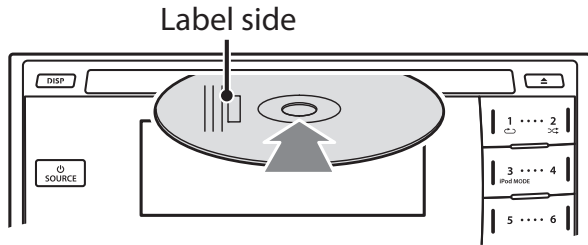

The source changes to “CD” and playback starts.

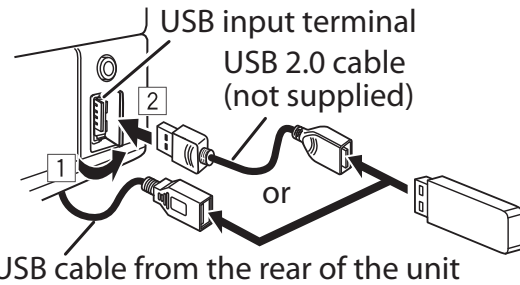

The source changes to “USB” and playback starts.

- This unit can play MP3/WMA files stored in CD-R, CD-RW, and MP3/WMA/WAV files in USB mass storage device (such as a USB memory and Digital Audio Player).
- Make sure all important data has been backed up. We shall bear no responsibility for any loss of data in USB mass storage class device while using this system.
- Ejected disc not removed within 15 seconds will reload automatically.
- If the disc cannot be ejected, page 3.

Selecting a folder/track

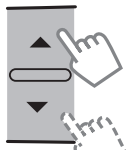

Selects folder.
(For MP3/WMA/WAV)



- Selects track. (Press)
- Fast-forwards or reverses the track. (Hold)

Selecting a track/folder from the list

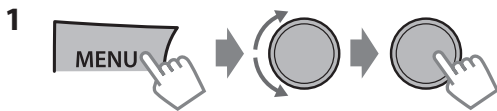

2 Select a folder. (For MP3/WMA/WAV)

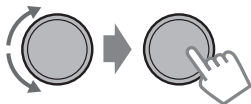

3 Select a track.

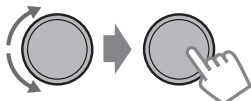

• For MP3/WMA/WAV

If there are many folders or tracks, you can fast search for the desired folder or track by turning the control dial quickly, or use Quick Search (page 13).

Selecting the playback modes

You can select one of the following playback modes at a time.

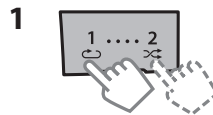

Press **1** for REPEAT.
Press **2** for RANDOM.
Press again to exit.

----- or -----

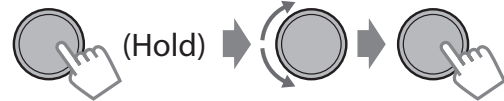

<REPEAT> ↔ <RANDOM>

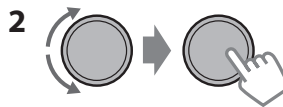

REPEAT

RPT OFF	Cancels repeat playback.
TRACK RPT	Repeats current track.
FOLDER RPT *	Repeats current folder.

RANDOM

RND OFF	Cancels random playback.
FOLDER RND *	Randomly plays all tracks of current folder, then tracks of next folders.
ALL RND	Randomly plays all tracks.

* For MP3/WMA/WAV

iPod/iPhone

Playing an iPod/iPhone

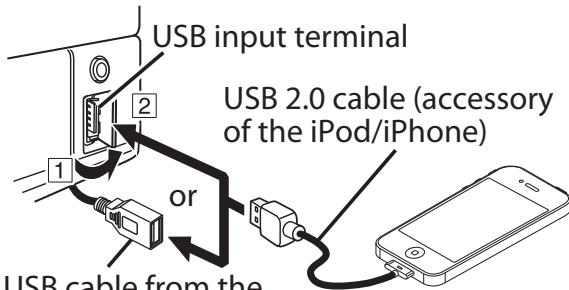

USB cable from the rear of the unit

The source changes to "IPOD-FRONT/IPOD-REAR" and playback starts.

Selecting the control mode

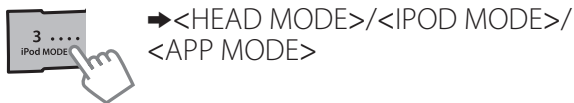

HEAD MODE	Controls iPod playback through this unit.
IPOD MODE	Controls iPod playback from the iPod/iPhone.
APP MODE	The sound of any functions (music, games, applications, etc.) running on the connected iPod/iPhone is emitted through the speakers connected to this unit.

- You can also change the setting using <IPOD SWITCH> in the menu. (page 25)

Selecting a track

Applicable under <HEAD MODE>/<IPOD MODE> only.
For <APP MODE>, applicable only for some audio applications.



- Selects track/chapter. (Press)
- Fast-forwards or reverses the track. (Hold)

Selecting a track from the list

Applicable under <HEAD MODE> only.



2 Select the desired list.

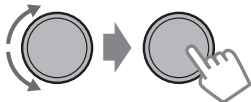

PLAYLISTS ↔ ARTISTS ↔ ALBUMS ↔ SONGS ↔
PODCASTS ↔ GENRES ↔ COMPOSERS ↔
AUDIOBOOKS ↔ (back to the beginning)

3 Select the desired track.

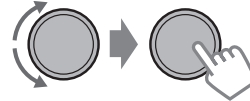

Repeat this step until the desired track is selected.

- If the selected menu contains many tracks, you can fast search for the desired track by turning the control dial quickly, or use Quick Search (page 13).

Selecting the playback modes

Applicable under <HEAD MODE> only.
You can select one of the following playback modes at a time.

- 1 Press **1** for REPEAT.
Press **2** for RANDOM.
Press again to exit.

----- or -----

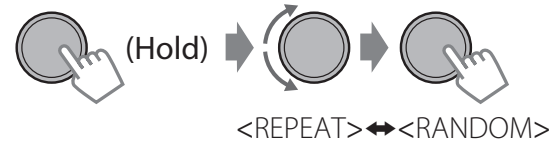

- 2 <REPEAT> ↔ <RANDOM>

REPEAT ↺

RPT OFF	Cancels repeat playback.
ONE RPT	Functions the same as "Repeat One" of the iPod.
ALL RPT	Functions the same as "Repeat All" of the iPod.

RANDOM ↻

RND OFF	Cancels random playback.
SONG RND	Functions the same as "Shuffle Songs" of the iPod.
ALBUM RND	Functions the same as "Shuffle Albums" of the iPod.

- "ALBUM RND" is not applicable for some iPod/iPhone.

iPod/iPhone application

You can operate JVC original application with this unit in <APP MODE>. For more details, visit JVC website: <<http://www3.jvckenwood.com/english/car/index.html>> (English website only).

Pandora® internet radio

Preparation

- 1 Search for "Pandora" in the Apple iTunes App Store to find and install the most current version of the Pandora® application onto your device.
- 2 In the application on your device, log in and create an account with Pandora®. If you are not a registered user, an account can also be created at www.pandora.com.
 - Pandora® is only available in the US.
 - Because Pandora® is a third-party service, the specifications are subject to change without prior notice. Accordingly, compatibility may be impaired or some or all of the services may become unavailable.
 - Some functions of Pandora® cannot be operated from this unit.
 - For issues using the application, please contact Pandora at pandora-support@pandora.com.

Listening to Pandora® internet radio

- 1 Open the Pandora® application on your device.
- 2 Connect the device to one of the USB terminals. (☞ page 11)
The source switches and broadcast starts automatically from your current station.

Basic Operations



Starts/pauses playback.

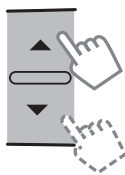

Selects thumbs up/thumbs down.
 • If thumbs down is selected, current track is skipped.



Skips track.

Creating a new station

You can create a new station based on the currently playing song or artist.

- 1 MENU
- 2 →<NEW STATION>
→<FROM ARTIST>/<FROM SONG>

A new station is created based on the current song or artist.

Searching the registered station from the list

- 1 MENU
- 2 Select the station list display mode.

BY DATE	According to the registration date
A - Z	Alphabetical order

You can proceed directly to step 3 to select station or use the search menu to scroll through the desired menu. (☞ page 13)

- 3 Select the desired station.

To bookmark song/artist information

While receiving a song...

- 1 (Hold) →<BOOKMARK>
- 2
- 3

<THIS ARTIST> ↔ <THIS TRACK>

"BOOKMARKED" appears and the song/artist information is stored to the iPod/iPhone.

- This unit allows you to bookmark songs and/or artists in your personalized Pandora® account. The bookmarks will not be available for review on the unit but will be available in your Pandora® account.

Quick Search

If you have many folders/tracks/contacts, you can search through them quickly according to the first character (A to Z, 0 to 9 and OTHERS).

1 Enter list menu or “Hands-Free” menu.

**CD (MP3/WMA)/
USB (MP3/WMA/WAV)**

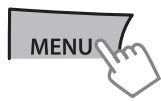

iPod/iPhone

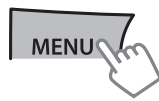

Select the desired list.

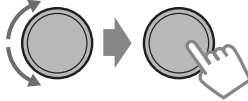

Bluetooth phonebook

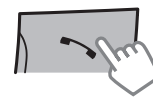

Select <PHONEBOOK>.

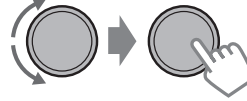

2 Select the desired character (A to Z, 0 to 9 and OTHERS).

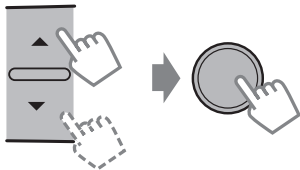

“OTHERS” appears if the first character is not A to Z or 0 to 9, such as #, -, !, etc.

3 Select your desired folder/track/contact.

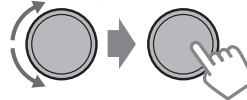

For CD/USB and iPod/iPhone, repeat step 3 until the desired track is selected.

- Searching may not work on some of the layers of the selected menu (for iPod/iPhone).

External components

You can connect an external component to the following terminals:

- **EXT IN:** Expansion port on the rear of this unit using the following adapters (not supplied):
 - JVC KS-U57, Line Input Adapter
 - JVC KS-U58, AUX Input Adapter
- **AUX IN:** AUX (auxiliary) input jack on the control panel.

For details, refer also to the instructions supplied with the adapters or external components.

For connection to expansion port on the rear of this unit, refer to the “Installation/Connection Manual”.

Playing an external component from AUX/expansion port

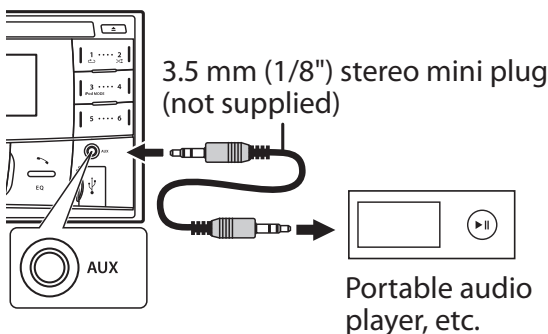

Use a 3-terminal plug head stereo mini plug for optimum audio output.

1 Connect to AUX on the control panel and/or the expansion port on the rear panel.

2 Set the source as necessary.



2 Select <AUX ON> or <EXT ON>.



3 Press **MENU** to exit.

3 Select <AUX IN> or <EXT IN>.



4 Turn on the connected component and start playing the source.

Bluetooth® connection

By connecting the supplied KS-UBT1 USB Bluetooth Adapter and microphone to this unit, you can operate a Bluetooth device using this unit. Refer to the “Installation/Connection Manual” for details on connecting the microphone.

Once the USB Bluetooth Adapter is attached, this unit is always available for pairing.

- Refer also to the instructions supplied with the Bluetooth device.
- Refer to the separate appendix to check the countries where you may use the Bluetooth function.
- If you turn off the unit or unplug the USB Bluetooth Adapter during a phone call conversation, the Bluetooth connection is disconnected. Continue the conversation using your mobile phone.

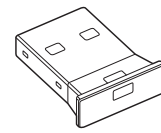

KS-UBT1

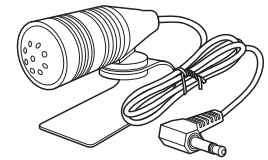

Microphone

This unit supports the following Bluetooth profiles

- Hands-Free Profile (HFP 1.5)
- Object Push Profile (OPP 1.1)
- Phonebook Access Profile (PBAP 1.0)
- Advanced Audio Distribution Profile (A2DP 1.2)
- Audio/Video Remote Control Profile (AVRCP 1.3)

Warning:

Stop the car in a safe place before operating complicated steps such as dialing numbers, using phonebook, etc.

Pairing a Bluetooth device

When connecting a Bluetooth device to the unit for the first time, perform pairing between the unit and the device.

- Up to five Bluetooth devices can be registered in this unit.
- A maximum of two Bluetooth phones and one Bluetooth audio device can be connected at any time.
- This unit supports Secure Simple Pairing (SSP).

- 1 Connect the USB Bluetooth adapter (KS-UBT1) to one of the USB input terminals.**

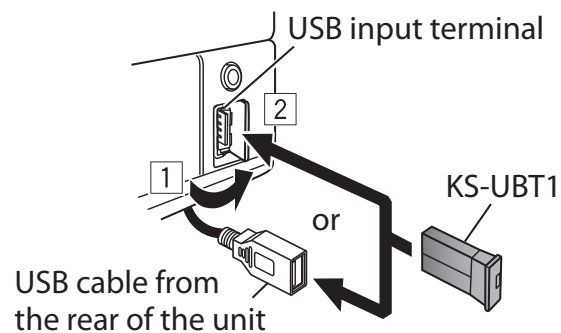

- 2 Search and select “JVC Unit” on the Bluetooth device.**

“BT PAIRING” flashes on the display.

- For some Bluetooth devices, you may need to enter the Personal Identification Number (PIN) code immediately after searching.

3 Perform (A) or (B) depending on what scrolls on the display.

- For some Bluetooth devices, pairing sequence may vary from the steps described below

(A) If “[Device Name]”⇒“XXXXXX”⇒“VOL – YES”⇒“BACK – NO” scrolls on the display,

- “XXXXXX” is a 6-digit passkey randomly generated during each pairing.

- 1 Ensure that the passkey which appears on the unit and Bluetooth device is the same.
- 2 Select “YES” to confirm the passkey.



- 3 Operate the Bluetooth device to confirm the passkey.

(B) If “[Device Name]”⇒“VOL – YES”⇒“BACK – NO” scrolls on the display,

- 1 Select “YES” to start the pairing.



- 2 (1) If “PAIRING”⇒“PIN 0000” scrolls on the display, enter the PIN code “0000” into the Bluetooth device.

- You can change to a desired PIN code before pairing. (☞ page 25)

- (2) If only “PAIRING” appears, operate the Bluetooth device to confirm pairing.

After pairing is successful, “PAIRING COMPLETED” appears on the display.

The unit will establish a connection with the newly paired Bluetooth device, “” lights up on the display and you can now control the Bluetooth device through the unit.

- “” will light up when a phone is connected.
- “” will light up when an audio device is connected.

- Once the connection is established, the device is registered to the unit and there is no need to perform the pairing again unless you delete the registered device.
- Some Bluetooth devices may not be able to connect to the unit after pairing. Connect the device to the unit manually. Refer to the instruction manual of the Bluetooth device for more information.

Connecting/Disconnecting a registered device manually

To connect

- 1 (Hold)

- 2 Select <CONNECT>.



- 3 Select the desired device.

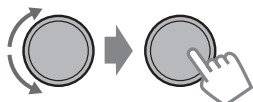

“CONNECTING”⇒ “[Device Name]” scrolls on the display when the unit is connecting to the device.

“CONNECTED”⇒ “[Device Name]” scrolls on the display when the device is connected.

- 4 Press **MENU** to exit.

To disconnect

- 1 (Hold)

- 2 Select <DISCONNECT>.



- 3 Select the desired device.

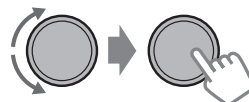

“DISCONNECT”⇒ “[Device Name]” scrolls on the display when the device is disconnected.

- 4 Press **MENU** to exit.

Bluetooth® connection

Connecting to JVC original application

JVC original application is designed to view JVC car receiver status and perform simple control operations on Android smart phones.

- For JVC original application operations, visit JVC website:
<<http://www3.jvckenwood.com/english/car/index.html>> (English website only).

1  (Hold)

2 Select <CONNECT>.

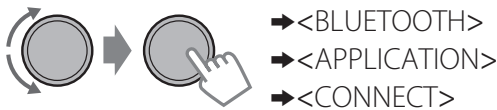

3 Select the desired smart phone.

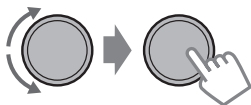

- “CONNECTED”⇒ “[Device Name]” scrolls on the display when the device is connected.

4 Press **MENU** to exit.

Deleting a registered device

1  (Hold)

2 Select <DELETE YES>.

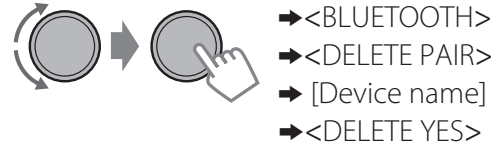

“DELETED” appears when the device is deleted.

3 Press **MENU** to exit.

Bluetooth mobile phone

Receiving a call

■ To receive a call

When there is an incoming call, the source automatically changes to “BT FRONT”/“BT REAR”.

- “RECEIVING” appears on the display, followed by the phone number or name.
- The display flashes in blue. (🔊 page 19)

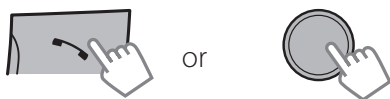

You can also press ▲/▼/◀/▶/**SOURCE** on the remote control to answer a call.

- When <AUTO ANSWER> is set to <ON>, the unit answers incoming calls automatically. (🔊 page 19)

■ To end a call

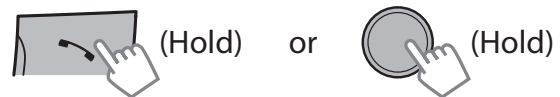

You can also press and hold ▲/▼/◀/▶/**SOURCE** on the remote control to end a call.

■ To deactivate/activate hands-free mode

During a phone conversation...



- Operations may vary according to the connected Bluetooth device.

Adjustments during a call



Phone volume (00 — 50)
[VOLUME 15]: Volume adjustments made during a call will not affect the other sources.

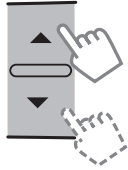

Microphone level (01 — 03) [02]: As the number increases, the microphone becomes more sensitive.



Noise Reduction and Echo Cancellation mode:
 Turns on/off.

Text message notification

When a text message is received, the unit rings and “RCV MESSAGE”⇒“[Device name]” appears.

- <MSG NOTICE> must be set to <ON>. (page 19)
- You cannot read, edit, or send a message through the unit.
- This feature is only available on certain phones.

Switching between two connected mobile phones

When two mobile phones are connected to the unit, you can access to both “Hands-Free” menus.

- Press ↶ to enter 1st phone’s “Hands-Free” menu.
- Press ↶ twice to enter 2nd phone’s “Hands-Free” menu.
- Press ↷ to return to 1st phone’s “Hands-Free” menu.

Making a call from the hands-free menu

1 Enter the “Hands-Free” menu.

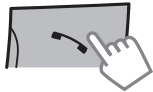

2 Select a calling method.

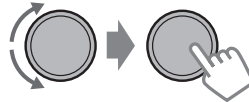

Refer to the table below for options.

3 Select and call the contact (name/phone number).

DIALED	Select the name/phone number	Call
RECEIVED		
MISSED CALL		
PHONEBOOK	If the phonebook contains many numbers, you can fast search for the desired number by turning the control dial quickly, or use Quick Search (page 13). <ul style="list-style-type: none"> • “NO HISTORY” appears if there is no recorded call history. • “NO DATA” appears if no entries are found in the Bluetooth device’s phonebook. • “SEND P.BOOK MANUALLY” appears if <P.BOOK SEL> is set to <P.BOOK IN UNIT> or the phone does not support PBAP. (page 19) 	
DIAL NUMBER	Enter the phone number to dial.	Call
	Select number/character	Move the entry position

Bluetooth mobile phone

Making a call from memory

You can store up to 6 contacts in the memory of this unit for speed dialing.

To store contacts in memory

- 1 Enter the "Hands-Free" menu.

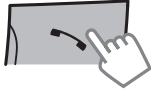

- 2 Select a call method.

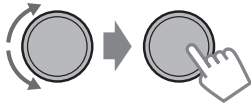

→ <DIALED>/
<RECEIVED>/
<MISSED CALL>/
<PHONEBOOK>/
<DIAL NUMBER>

- 3 Select a contact (name/phone number).

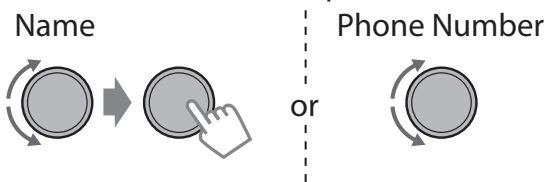

- 4 Store in memory.

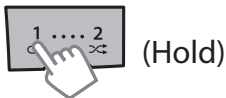

"MEMORY PX" flashes. The contact is stored to the selected number button (1 - 6).

- To erase a contact from preset memory, select <DIAL NUMBER> in step 2 and store a blank number.

To make a call from memory

- 1 Enter the "Hands-Free" menu.

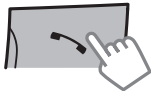

- 2 Select and call the contact.



- "NO PRESET" appears if there are no contacts stored in memory.

Using voice recognition

You can use the voice recognition features of the connected phone through this unit.

- "NOT SUPPORT" appears if the connected phone does not support this feature.

- 1 Enter voice recognition mode.

If only one phone is connected,



If two phones are connected,

Enter "phone list" → Select the desired phone



- 2 When "WAIT VOICE" ⇒ "[Device Name]" scrolls on the display, speak the name of the contact you want to call or the voice command to control the phone functions.

Supported voice recognition features vary for each phone. Please refer to the instruction manual of the connected phone for details.

Deleting a contact (name/ phone number)

Only when <P.BOOK SEL> is set to <P.BOOK IN UNIT>. (page 19)

- 1 Enter the "Hands-Free" menu.

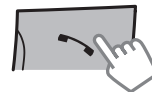

- 2 Select a call method.

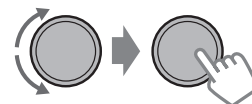

→ <DIALED>/
<RECEIVED>/
<MISSED CALL>/
<PHONEBOOK>

- 3 Select the contact (name/phone number) to be deleted.

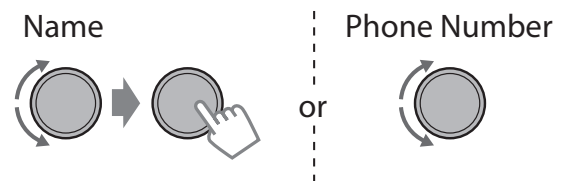

- 4 Enter "Delete Entries" menu.



- 5 Select <DELETE> or <DELETE ALL>.

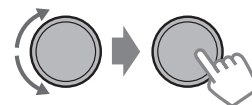

DELETE	Selected name/phone number from step 3 is deleted.
DELETE ALL	All name/phone numbers from selected menu in step 2 are deleted.

Using the SETTINGS menu

1 Enter the “Hands-Free” menu.



2 Select <SETTINGS>.

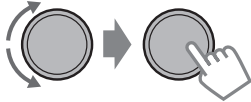

3 Repeat this step to perform the necessary settings.

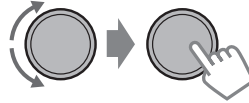

- To return to the previous menu, press ↶.
- To exit from the menu, press **MENU**.

The following settings are applicable to the paired device. If another device is paired, perform the settings again.

Menu item	Selectable setting (Initial: [XX])
P.BOOK SEL *	[PB IN PHONE]: The unit browses the phonebook of the connected phone. PB IN UNIT: The unit browses the phonebook registered in the unit. (You can copy the phonebook memory using <P.BOOK WAIT> (☞ page 25).)
AUTO ANSWER	[ON]: The unit answers incoming calls automatically. [OFF]: The unit does not answer incoming calls automatically.
RING TONE	[IN UNIT]: The unit rings to alert you when a call/text message comes in. – CALL: Select your preferred ring tone (TONE 1 — 5) for incoming calls. – MESSAGE: Select your preferred ring tone (TONE 1 — 5) for incoming text messages. • Default ring tone is different according to the paired device. IN PHONE: The unit uses the connected phones' ring tone to alert you when a call/text message comes in. (The connected phone will ring if it does not support this feature.)
RING COLOR	COLOR 01 — 29 [06]: Select your preferred color for incoming call/text message alerts. [OFF]: Cancels.
NR/EC MODE	[ON]: Turns on the Noise Reduction and Echo Cancellation of the connected microphone for clearer sound. [OFF]: Cancels.
MIC LEVEL	(01— 03) [02]: The sensitivity of the microphone increases as the MIC level is increased.
MSG NOTICE	[ON]: The unit rings and “RCV MESSAGE”⇒“[Device Name]” appears to alert you of an incoming text message. [OFF]: The unit does not alert you of an incoming text message.

* Selectable only when the connected phone supports PBAP.

Bluetooth audio player

Playing a Bluetooth audio player

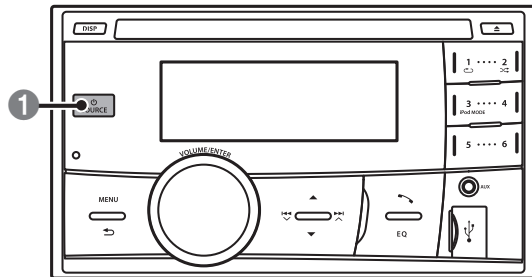

- 1 Select <BT REAR> or <BT FRONT> depending on the location of the USB Bluetooth adapter KS-UBT1.
 - Operate the Bluetooth audio player to start playback.

Operations and display indications may differ according to their availability on the connected device.

Basic operations

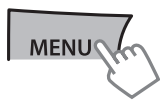

Starts or resumes playback.



Mutes the sound.



Selects group/folder.



Reverse skips or forward skips. (Press)
Fast-forwards or reverses the track. (Hold)

Selecting the playback modes

For Bluetooth devices that support AVRCP 1.3.

- 1  Press **1** for REPEAT. Press **2** for RANDOM. Press again to exit.

or

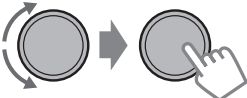

- 2 

REPEAT

RPT OFF	Cancels repeat playback.
TRACK RPT	Repeats current track.
ALL RPT	Repeats all tracks.
GROUP RPT	Repeats all tracks of the current group.

RANDOM

RND OFF	Cancels random playback.
ALL RND	Randomly plays all tracks.
GROUP RND	Randomly plays all tracks of the current group.

Listening to BT Pandora® internet radio

You can listen to Pandora® internet radio on your smart phone through Bluetooth on this unit.



- 1 Open the Pandora® application on your device.
- 2 Connect to Bluetooth audio. Refer to "To connect"  page 15, select <BLUETOOTH>⇒<AUDIO>⇒<CONNECT>.
- 3 Select <BT REAR> or <BT FRONT> depending on the location of the USB Bluetooth adapter KS-UBT1.



- 4 Press **3** to select <BT PANDORA>.



The source switches and broadcast starts automatically.

- You can also activate Pandora® on your Bluetooth smart phone via <BT AUDIO SW>. ( page 25)
- BT Pandora® internet radio is only for Android OS and RIM OS.
- You can operate Pandora® in the same way as Pandora® for iPod/iPhone. ( page 12)

Illumination color adjustments

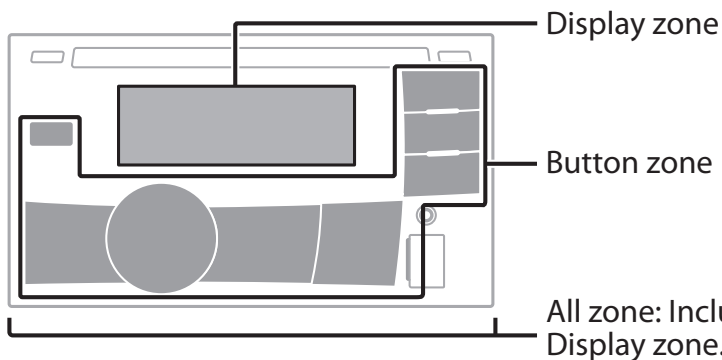

Selecting the preset color

You can select a preset color for <BUTTON ZONE>, <DISP ZONE>, and <ALL ZONE> separately.

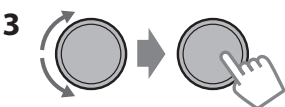
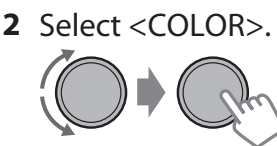

BUTTON ZONE	COLOR 01-29/USER/ COLOR FLOW 01-03*
DISP ZONE	* Color changes in different speeds.
ALL ZONE	

- Initial color: BUTTON ZONE [06], DISP ZONE [01], ALL ZONE [06].
- If <ALL ZONE> is selected, the button and display illumination will change to the current/selected <BUTTON ZONE> color.

4 Press **MENU** to exit.

Storing your own adjustments

You can store your own day and night colors for <BUTTON ZONE> and <DISP ZONE> separately.

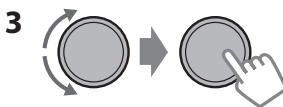
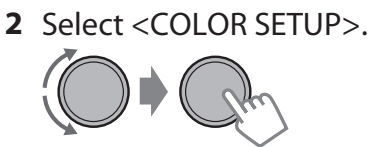

DAY COLOR	BUTTON ZONE	<ul style="list-style-type: none"> • Select a primary color <RED/GREEN/BLUE>, and then adjust the level <00-31>. Repeat this procedure until you have adjusted all the three primary colors.
	DISP ZONE	
NIGHT COLOR	BUTTON ZONE	<ul style="list-style-type: none"> • Your adjustment is automatically stored to "USER". • If "00" is selected for all the primary colors for <DISP ZONE>, nothing appears on the display.
	DISP ZONE	
MENU COLOR	ON	Changes the display and buttons illumination during menu, list search, and playback mode operations.
	OFF	



- NIGHT COLOR/DAY COLOR is changed by turning on/off your car's headlight.



4 Press **MENU** to exit.

Brightness adjustments

You can select your preferred brightness for <BUTTON ZONE>, <DISP ZONE> separately.

1  (Hold)

2  →  →  → 
 → <DIMMER>
 → <BRIGHTNESS>
 → <DAY>/<NIGHT>

3  → 

BUTTON ZONE	BUTTON 00 to 31
DISP ZONE	DISP 00 to 31

4 Press **MENU** to exit.



Sound adjustments

This unit memorizes sound settings adjusted for each individual source.

HD Radio tuner, Satellite Radio tuner and EXT IN share the same sound adjustment settings.

Selecting the preset sound

You can select a preset sound mode, for each individual source, suitable for the music genre.

 →  → 

----- or -----
 Press repeatedly.

DYNAMIC → VOCAL BOOST → BASS BOOST →
 USER → FLAT → NATURAL → (back to the beginning)



Storing your own adjustments

While listening, you can adjust and store the tone level for each individual source.

Easy Equalizer

1  (Hold)

2 Adjust the level.

 → 



(Initial: **[XX]**)



SUB.W *	00 to 08 [08]
BASS LVL **	-06 to +06 [+05]
MID LVL	-06 to +06 [00]
TRE LVL	-06 to +06 [+05]

The adjustments are stored and <USER> is activated.

Pro Equalizer

1  (Hold)

2  →  → 
 → <PRO EQ>
 → <BASS>** / <MIDDLE> / <TREBLE>

3  → 

Adjust the sound elements of the selected tone.

BASS (Initial: **[XX]**)

Frequency	60/80/[100]/200 Hz
Level	LVL -06 to +06 [+05]
Q	[Q1.0] /Q1.25/Q1.5/Q2.0

MIDDLE

Frequency	0.5/[1.0]/1.5/2.5 kHz
Level	LVL -06 to +06 [00]
Q	Q0.75/Q1.0/[Q1.25]

TREBLE

Frequency	10.0/[12.5]/15.0/17.5 kHz
Level	LVL -06 to +06 [+05]
Q	[Q FIX]

4 Repeat steps 2 and 3 to adjust other tones. The adjustments are stored and <USER> is activated.

5 Press **MENU** to exit.

* Available only when <L/O MODE> is set to <SUB.W>. (☞ page 24)

** Available only when <HPF> is set to <OFF>. (☞ page 24)

Menu operations



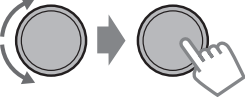

1  (Hold)

If no operation is done for about 60 seconds, the operation will be canceled.

2 

3 Repeat step 2 if necessary.

- To return to the previous menu, press .
- To exit from the menu, press **DISP** or **MENU**.

	Menu item	Selectable setting (Initial: [XX])
	DEMO	For settings,  page 4.
CLOCK	CLOCK SET	For settings,  page 4.
	CLOCK ADJ	[AUTO] : The built-in clock is automatically adjusted using the clock data provided via the Satellite Radio channel. OFF : Cancels.
	TIME ZONE *1*2	[EASTERN]/ATLANTIC/NEWFOUND/ALASKA/PACIFIC/MOUNTAIN/CENTRAL : Selects your residential area from one of the time zones for clock adjustment.
	DST *1*2	[DST ON] : Activates daylight savings time if your residential area is subject to DST. DST OFF : Cancels.
	COLOR	For settings,  page 21.
	COLOR SETUP	
DIMMER	DIMMER SET	Selects the display and button illumination adjusted in the <BRIGHTNESS>/<COLOR SETUP> setting. [AUTO] : Changes between the Day and Night adjustments when you turn off/on the car headlights. *3 ON : Selects the Night adjustments. OFF : Selects the Day adjustments.
	BRIGHTNESS	DAY[31]/NIGHT[15] : Brightness settings for the display and button illumination for day and night. BUTTON ZONE/DISP ZONE : Sets the brightness levels 00 — 31 .
DISPLAY	SCROLL *4	[ONCE] : Scrolls the display information once. AUTO : Repeats scrolling (at 5-second intervals). OFF : Cancels.
	TAG DISPLAY	[ON] : Shows the TAG information while playing MP3/WMA/WAV tracks. OFF : Cancels.
	PRO EQ	For settings,  page 22.



*1 Displayed only when SIRIUS Satellite Radio or XM Satellite Radio is connected.

*2 Displayed only when <CLOCK ADJ> is set to <AUTO>.

*3 The illumination control lead connection is required. (See “Installation/Connection Manual”.) This setting may not work correctly on some vehicles (particularly on those having a control dial for dimming). In this case, change the setting to other than <DIMMER AUTO>.

*4 Some characters or symbols will not be shown correctly (or will be blanked) on the display.

Menu operations







Menu item	Selectable setting (Initial: [XX])	
FADER *5*6	R06 — F06 [00] : Adjusts the front and rear speaker output balance.	
BALANCE *6	L06 — R06 [00] : Adjusts the left and right speaker output balance.	
LOUD (Loudness)	ON : Boosts low and high frequencies to produce a well-balanced sound at a low volume level. [OFF] : Cancels.	
VOL ADJUST (Volume adjust)	-05 — +05 [00] : Presets the volume adjustment level of each source, compared to the FM volume level. Before adjustment, select the source you want to adjust. ("VOL ADJ FIX" appears if "FM" is selected.)	
L/O MODE (Line output mode)	Select if the LINE OUT (REAR) terminals on the rear panel are connected to the speakers or subwoofer through an external amplifier. SUB.W : Subwoofer [REAR] : Speakers	
AUDIO	SUB. W *7 (Subwoofer)	OFF : Cancels. [ON] : Turns on the subwoofer output.
	SUB.W LPF *8 (Subwoofer low-pass filter)	LOW 55Hz/MID 85Hz/[HIGH 120Hz] : Audio signals with frequencies lower than 55 Hz/85 Hz/120 Hz are sent to the subwoofer.
	SUB.W LEVEL *8 (Subwoofer level)	00 — 08 [08] : Adjusts the subwoofer output level.
	HPF *8 (High-pass filter)	ON : Activates the High Pass Filter. Low frequency signals are cut off from the front/rear speakers. [OFF] : Deactivates. (All signals are sent to the front/rear speakers.)
	BEEP (Keypress tone)	[ON]/[OFF] : Activates or deactivates the keypress tone.
	AMP GAIN (Amplifier gain)	LOW POWER : Limits the maximum volume level to 30. (Select if the maximum input power of each speaker is less than 50 W to prevent damaging the speakers.) [HIGH POWER] : The maximum volume level is 50.
	SSM	For settings,  page 6. (Displayed only when the source is "FM".)
TUNER	AREA (Frequency tuning interval)	[AREA US] : For North/Central/South America, AM/FM intervals: 10 kHz/200 kHz. AREA EU : For any other areas, AM/FM intervals: 9 kHz/50 kHz. AREA SA : For some South American countries, AM/FM intervals: 10 kHz/50 kHz.
	MONO (Monaural mode)	Displayed only when the source is "FM". [OFF] : Enables stereo FM reception. ON : Improves the FM reception but stereo effect will be lost.
	SID	The 12-digit SIRIUS identification number appears on the display. (Displayed only when SIRIUS Satellite Radio is connected.)
	BLEND HOLD	For settings,  page 8. (Displayed only when the source is "FM" or "AM".)
	IF BAND (Intermediate frequency band)	[AUTO] : Increases the tuner selectivity to reduce interference noises between adjacent stations. (Stereo effect may be lost.) WIDE : Subject to interference noises from adjacent stations, but sound quality will not be degraded and the stereo effect will remain.
	RADIO TIMER	For settings,  page 7.

*5 If you are using a two-speaker system, set the fader level to "00".

*6 This adjustment will not affect the subwoofer output.

*7 Displayed only when <L/O MODE> is set to <SUB.W>.

*8 Displayed only when <SUB.W> is set to <ON>.

Menu item	Selectable setting (Initial: [XX])	
USB *9	DRIVECHANGE: Selects to change the drive when a device with multiple drives is connected to the USB input terminal (front/rear).	
IPOD SWITCH *10 (iPod/iPhone control)	[HEAD MODE]/IPOD MODE/APP MODE: For settings,  page 11.	
AUDIOBOOKS *10	NORMAL/FASTER/SLOWER: Selects the playback speed of the Audiobooks sound file in your iPod/iPhone. Initial selection depends on your iPod/iPhone setting.	
BLUETOOTH *11	PHONE *12	CONNECT/DISCONNECT: Connects or disconnects the Bluetooth phone/ audio device. ( page 15)
	AUDIO	
	APPLICATION	CONNECT/DISCONNECT: Connects or disconnects the application in the smart phone. ( page 16)
	BT AUDIO SW *13	Switches between "BT AUDIO" and "BT PANDORA".
	DELETE PAIR	For settings,  page 16.
	P. BOOK WAIT	Copies up to 400 numbers from the phonebook memory of a connected phone to the unit via OPP.
	SET PINCODE	Changes the PIN code (1 to 6-digits). (Default PIN code: 0000) Turn the control dial to select a number, press  /  to move to the entry position. After entering the PIN code, press the control dial to confirm.
	AUTO CNNECT	[ON]: Establishes connection automatically with the Bluetooth device when the unit is turned on. OFF: Cancels.
	INITIALIZE	YES: Initializes all the Bluetooth settings (including stored pairing, phonebook, and etc.). [NO]: Cancels.
	INFORMATION	PH CNNT DEV/AU CNNT DEV/APP CNT DEV *14: Displays connected phone/audio/application device name. MY BT NAME: Displays the unit name (JVC Unit). MY ADDRESS: Shows address of USB Bluetooth Adapter.
SRC SELECT	AM *15	[ON]/OFF: Enables or disables "AM" in source selection.
	EXT IN *15	EXT ON/[EXT OFF]: Enables or disables "EXT IN" in source selection.
	AUX IN *15	[AUX ON]/AUX OFF: Enables or disables "AUX IN" in source selection.
	BT AUDIO *16	[BT AU ON]/BT AU OFF: Enables or disables "BT AUDIO" in source selection.
SOFT VER	Displays the firmware version of the unit.	

*9 Displayed only when the source is "USB FRONT/USB REAR".

*10 Displayed only when the source is "IPOD-FRONT/IPOD-REAR".

*11 If the USB Bluetooth Adapter is not connected to the unit, "PLEASE CNNT BT ADAPTER" scrolls on the display.

*12 <CONNECT> will not be displayed if two Bluetooth phones are connected at the same time.

*13 Displayed only when the source is "BT FRONT/BT REAR".

*14 Displayed only when a Bluetooth phone/audio player/application is connected.

*15 Displayed only when the unit is in any source other than the corresponding source "AM/EXT IN/AUX IN".

*16 Displayed only when the USB Bluetooth Adapter (KS-UBT1) is attached and current source is not "BT FRONT/ BT REAR".

Remote controller

Preparing

When you use the remote controller for the first time, pull out the insulation sheet.



For USA-California Only:
This product contains a CR Coin Cell Lithium Battery which contains Perchlorate Material—special handling may apply. See www.dtsc.ca.gov/hazardouswaste/perchlorate

Replacing the lithium coin battery

- If the effectiveness of the remote controller decreases, replace the battery.

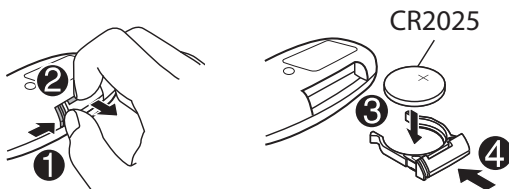

Caution:

- Danger of explosion if battery is incorrectly replaced. Replace only with the same or equivalent type.
- Battery shall not be exposed to excessive heat such as sunshine, fire, or the like.

Warning:

- Do not install any battery other than CR2025 or its equivalent.
- Do not leave the remote controller in places (such as dashboards) exposed to direct sunlight for a long time.
- Store the battery in places out of reach of children.
- Do not recharge, short, disassemble, heat the battery, or dispose of it in a fire.
- Do not place the battery with other metallic materials.
- Do not poke the battery with tweezers or similar tools.
- Insulate the battery by wrapping it with tape when disposing or storing it.

This unit is equipped with the steering wheel remote control function. For details, refer also to the instructions supplied with the remote adapter.

Additional information

About discs

This unit can only play the following CDs:



This unit can play back multi-session discs; however, unclosed sessions will be skipped during playback.

Unplayable discs

- Discs that are not round.
- Discs with coloring on the recording surface or discs that are dirty.
- Recordable/ReWritable disc that has not been finalized. (For details on disc finalization, refer to your disc writing software and your disc recorder instruction manual.)
- 8 cm (3 inch) CD. Attempting to insert using an adapter can cause malfunction. There may also be problems ejecting the disc if inserted.

Handling discs

- Do not touch the recording surface of the disc.
- Do not stick tape etc. on the disc, or use a disc with tape stuck on it.
- Do not use any accessories for the disc.
- Clean from the center of the disc and move outwards.
- Clean the disc with a dry silicon or soft cloth. Do not use any solvents.
- When removing discs from this unit, pull them out horizontally.
- Remove any burrs from the center hole and disc edge before inserting a disc.

DualDisc playback

The Non-DVD side of a “DualDisc” does not comply with the “Compact Disc Digital Audio” standard. Therefore, the use of Non-DVD side of a DualDisc on this product may not be recommended.

About audio files

■ Playable files

- File extensions: MP3(.mp3), WMA(.wma), WAV(.wav)

For MP3/WMA discs:

- Bit rate:
MP3/WMA: 5 kbps - 320 kbps
- Sampling frequency:
MP3 (MPEG-1): 32 kHz, 44.1 kHz, 48 kHz
MP3 (MPEG-2): 16 kHz, 22.05 kHz, 24 kHz
WMA: 8 kHz - 48 kHz

For USB devices:

- Bit rate:
MP3 (MPEG-1): 32 kbps - 320 kbps
MP3 (MPEG-2): 8 kbps - 160 kbps
WMA: 5 kbps - 320 kbps
WAV: Linear PCM at 705 kbps and 1 411 kbps
- Sampling frequency:
MP3 (MPEG-1): 32 kHz, 44.1 kHz, 48 kHz
MP3 (MPEG-2): 16 kHz, 22.05 kHz, 24 kHz
WMA: 8 kHz - 48 kHz
WAV: 44.1 kHz
- Channel:
WMA/WAV: 1 ch/2 ch
- Variable bit rate (VBR) files. (The elapsed time for VBR files will not be displayed correctly.)

■ Unplayable files

- MP3 files:
 - encoded in MP3i and MP3 PRO format
 - encoded in an inappropriate format
 - encoded with Layer 1/2
- WMA files:
 - encoded in lossless, professional, and voice format
 - not based upon Windows Media® Audio
 - copy-protected with DRM
- Files which include data such as AIFF, ATRAC3, etc.

■ File/folder names

This unit supports files/folder names recorded in a format compliant with ISO 9660 Level 1, Level 2, Romeo, or Joliet, and the proper extension code <.mp3>, <.wma> or <.wav>.

■ Others

- This unit can show WMA Tag and ID3 Tag Version 1.0/1.1/2.2/2.3/2.4 (for MP3).
- The search function works but search speed is not constant.

About USB device

- When connecting a USB cable, use the USB 2.0 cable.
- You cannot connect a computer or portable HDD to the USB input terminal of the unit.
- Connect only one USB device to the unit at a time. Do not use a USB hub.
- USB devices equipped with special functions such as data security functions cannot be used with the unit.
- Do not use a USB device with 2 or more partitions.
- This unit cannot recognize a USB device whose rating is other than 5 V and exceeds 1 A.
- This unit may not recognize a memory card inserted into the USB card reader.
- This unit may not play back files in a USB device properly when using a USB extension cord.
- Depending on the shape of the USB devices and connection ports, some USB devices may not be attached properly or the connection might be loose.
- Operation and power supply may not work as intended for some USB devices.
- The maximum number of characters for:
 - Folder names: 25 characters
 - File names: 25 characters
 - MP3 Tag: 128 characters
 - WMA Tag: 128 characters
 - WAV Tag: 128 characters
- This unit can recognize a total of 20 000 files, 2 000 folders (999 files per folder including folder without unsupported files), and of 8 hierarchies. However, the display can only show until 999 folders/files.

■ Cautions

- Do not pull out and attach the USB device repeatedly while "READING" is shown on the display.
- Electrostatic shock at connecting a USB device may cause abnormal playback of the device. In this case, disconnect the USB device then reset this unit and the USB device.
- Do not leave a USB device in the car, expose to direct sunlight, or high temperature. Failure to do so may result in deformation or cause damages to the device.

About iPod/iPhone

- iPod/iPhone that can be connected to this unit:
 - iPod touch (4th generation)
 - iPod touch (3rd generation)
 - iPod touch (2nd generation)
 - iPod touch (1st generation)
 - iPod classic
 - iPod with video (5th generation)*
 - iPod nano (6th generation)
 - iPod nano (5th generation)
 - iPod nano (4th generation)
 - iPod nano (3rd generation)
 - iPod nano (2nd generation)
 - iPod nano (1st generation)*
 - iPhone 4S
 - iPhone 4
 - iPhone 3GS
 - iPhone 3G
 - iPhone
- *<IPOD MODE>/<APP MODE> are not applicable.
- It is not possible to browse video files on the "Videos" menu in <HEAD MODE>.
- The song order displayed on the selection menu of this unit may differ from that of the iPod.
- When operating an iPod/iPhone, some operations may not be performed correctly or as intended. In this case, visit the following JVC website:
<<http://www3.jvckenwood.com/english/car/index.html>> (English website only).

About Bluetooth

- Depending on the Bluetooth version of the device, some Bluetooth devices may not be able to connect to this unit.
- This unit may not work with some Bluetooth devices.
- Signal conditions vary, depending on the surroundings.
- When the unit is turned off, the device is disconnected.
- For more information about Bluetooth, visit the following JVC website:
<<http://www3.jvckenwood.com/english/car/index.html>> (English website only)

Trademark and license notice

- Microsoft and Windows Media are either registered trademarks or trademarks of Microsoft Corporation in the United States and/or other countries.
- The Bluetooth word mark and logos are owned by the Bluetooth SIG, Inc. and any use of such marks by JVC KENWOOD Corporation is under license. Other trademarks and trade names are those of their respective owners.
- Ready to receive HD Radio broadcasts when connected to the KT-HD300, sold separately.
- SIRIUS, XM and SAT Radio Ready, and related marks are registered trademarks of SIRIUS XM Radio Inc. All rights reserved.
- "Made for iPod" and "Made for iPhone" mean that an electronic accessory has been designed to connect specifically to iPod, or iPhone, respectively, and has been certified by the developer to meet Apple performance standards. Apple is not responsible for the operation of this device or its compliance with safety and regulatory standards. Please note that the use of this accessory with iPod, or iPhone may affect wireless performance.
- iPhone, iPod, iPod classic, iPod nano, and iPod touch are trademarks of Apple Inc., registered in the U.S. and other countries.
- PANDORA, the PANDORA logo, and the Pandora trade dress are trademarks or registered trademarks of Pandora Media, Inc., used with permission.

Troubleshooting

Symptom	Remedy/Cause	
■ General		
No sound, sound interrupted or static noise.	<ul style="list-style-type: none"> • Check the cords, antenna and cable connections. • Check the condition of the disc, connected device and recorded tracks. • Ensure to use the recommended stereo mini plug when connecting to an external component. (🔧 page 13) 	
“MISWIRING CHK WIRING THEN RESET UNIT”/“WARNING CHK WIRING THEN RESET UNIT” appears on the display and no operations can be done.	<p>Ensure the terminals of the speaker leads are properly insulated with tape before resetting the unit. (🔧 page 3)</p> <p>If the message does not disappear, consult your JVC car audio dealer or kits supplying company.</p>	
The unit does not work at all.	Reset the unit. (🔧 page 3)	
Source cannot be selected.	Check the <SRC SELECT> setting. (🔧 page 25)	
The correct characters are not displayed (e.g. album name).	This unit can only display letters (upper case), numbers, and a limited number of symbols.	
■ FM/AM		
SSM automatic presetting does not work.	Store stations manually.	
■ CD/USB/iPod/iPhone		
“PLEASE” and “EJECT” appear alternately on the display.	Press [▲], then insert the disc correctly.	
“IN DISC” appears on the display.	The disc cannot be ejected properly. Make sure nothing is blocking the loading slot.	
“READING” keeps flashing on the display.	<ul style="list-style-type: none"> • A longer readout time is required. Do not use too many hierarchical levels and folders. • Reload the disc or reattach the USB device. 	
Tracks/folders are not played back in the order you have intended.	The playback order is determined by the file name (USB) or the order in which files were recorded (disc).	
The elapsed playing time is not correct.	This sometimes occurs during playback. This is caused by how the tracks are recorded on the disc.	
“NO FILE” appears on the display.	Check whether the selected folder, the connected USB device, or the iPod/iPhone contains a playable file.	
“NOT SUPPORT” appears on the display and track skips.	Check whether the track is a playable file format.	
<ul style="list-style-type: none"> • “CANNOT PLAY” flashes on the display. • The unit cannot detect the connected device. 	<ul style="list-style-type: none"> • Check whether the connected device is compatible with this unit. (USB: 🔧 page 32) (iPod/iPhone: 🔧 page 28) • Ensure that the device contains files in the supported formats. (🔧 page 27) • Reattach the device. 	
The iPod/iPhone does not turn on or does not work.	<ul style="list-style-type: none"> • Check the connection between this unit and iPod/iPhone. • Detach and reset the iPod/iPhone using hard reset. For details on resetting the iPod/iPhone, refer to the instruction manual supplied with the iPod/iPhone. • Check whether <IPOD SWITCH> setting is appropriate. (🔧 page 11) 	
Pandora®	“CANNOT SKIP”	The skip limit has been reached.
	“NO STATION”	No registered station in your iPod/iPhone.
	“NO ACTIVE STATION”	No active station.
	“SET UP PANDORA ON YOUR DEVICE”	Pandora® setup is not completed. Connect the iPod/iPhone to this unit after completing the setup in your iPod/iPhone.

Troubleshooting

Symptom	Remedy/Cause	
■ CD/USB/iPod/iPhone		
Pandora®	New station creation:	
	"NO STATION"	There are no stations found for the current song or artist.
	"STATION REACH LIMIT"	You may not create more than 100 stations.
	"CANNOT MAKE NEW STATION"	There is a problem creating a new station, such as a network issue.
■ HD Radio		
Sound quality changes when receiving HD Radio stations.	Fix the reception mode to either <ANALOG> or <DIGITAL>. (🔧 page 8)	
No sound can be heard.	<ul style="list-style-type: none"> • <ANALOG> is selected when receiving all digital broadcast of HD Radio station. Select <AUTO> or <DIGITAL>. (🔧 page 8) • <DIGITAL> is selected when receiving weak digital signals or receiving conventional radio broadcast. Select <AUTO> or <ANALOG>. (🔧 page 8) 	
"RESET 8" appears on the display.	Reconnect this unit and the HD Radio tuner box correctly, then reset the unit.	
■ Satellite Radio		
"UNSUB CH" appears on the display while listening to the SIRIUS Satellite Radio.	SIRIUS Satellite Radio is connected but does not have an active subscription. For information on how to subscribe, 📖 page 9.	
No sound can be heard. "UPDATING" appears on the display.	The unit is updating the channel information and it takes a few minutes to complete.	
"NO SIG" or "NO SIGNAL" appears on the display.	Make sure your Satellite Radio antenna is mounted outside the vehicle. Move the vehicle to an area with a clear view of the sky.	
"NO ANT" or "NO ANTENNA" appears on the display.	Check your Satellite Radio antenna connection and be sure it is firmly attached.	
"INVALID CH" appears on the display for about 5 seconds, then returns to the previous channel or default channel while listening to the SIRIUS Satellite Radio.	<ul style="list-style-type: none"> • No broadcast on the selected channel. • Select another channel or continue listening to the previous channel or default channel. 	
Blank display appears.	No text information for the selected channel.	
"NO CH AV" or "CH UNAVL" appears on the display for about 2 seconds, then returns to the previous channel while listening to the XM Satellite Radio.	<ul style="list-style-type: none"> • Selected channel is no longer available or is unauthorized. • Select another channel or continue listening to the previous channel. 	
"OFF AIR" appears on the display while listening to the XM Satellite Radio.	<ul style="list-style-type: none"> • Selected channel is not broadcasting at this time. • Select another channel or continue listening to the previous channel. 	
"LOADING" appears on the display while listening to the XM Satellite Radio.	<ul style="list-style-type: none"> • The unit is loading the channel information and audio. • Text information are temporarily unavailable. 	
"RESET 8" appears on the display. Satellite Radio does not work at all.	Reconnect this unit and the Satellite Radio correctly and reset this unit.	

Symptom	Remedy/Cause
Bluetooth	
"BT FRONT"/"BT REAR" cannot be selected.	Check <BT AUDIO> in the <SRC SELECT> setting. (☞ page 25)
No Bluetooth device is detected.	<ul style="list-style-type: none"> • Search from the Bluetooth device again. • Reset the unit. (☞ page 3)
Pairing cannot be made.	<ul style="list-style-type: none"> • Make sure you have entered the same PIN code to both the unit and Bluetooth device. • Delete pairing information from both the unit and the Bluetooth device, then perform pairing again.
"PAIRING FULL" scrolls on the display when trying to perform pairing.	<ul style="list-style-type: none"> • You have already registered the maximum of five Bluetooth devices in the unit. To pair another device, delete an existing paired device from the unit first. (☞ page 16)
Echo or noise occurs.	<ul style="list-style-type: none"> • Adjust the microphone unit's position. • Adjust <NR/EC MODE> and <MIC LEVEL> to a better combination. (☞ page 19)
Phone sound quality is poor.	<ul style="list-style-type: none"> • Reduce the distance between the unit and the Bluetooth device. • Move the car to a place where you can get a better signal reception.
The unit does not respond when you try to copy the phonebook to the unit.	You may have tried to copy the same entries (as stored) to the unit. Press DISP or ↶ to exit.
Sound is being interrupted or skipped during playback of a Bluetooth audio player.	<ul style="list-style-type: none"> • Reduce the distance between the unit and the Bluetooth audio player. • Turn off, then turn on the unit and try to connect again. • Other Bluetooth devices might be trying to connect to the unit.
The connected Bluetooth audio player cannot be controlled.	<ul style="list-style-type: none"> • Check whether the connected Bluetooth audio player supports Audio/Video Remote Control Profile (AVRCP). (Refer to the instructions of your audio player.) • Disconnect and connect the Bluetooth player again.
"VOICE" calling method is not successful.	<ul style="list-style-type: none"> • Use "VOICE" calling method in a more quiet environment. • Reduce the distance from the microphone when you speak the name. • Change "NR/EC MODE" to "OFF" (☞ page 19), then try again.
"NOT SUPPORT" appears when trying to perform voice dial.	The connected phone does not support this feature.
"ERROR CNNCT" appears on the display.	The device is registered but the connection has failed. Connect the device manually. (☞ page 15)
"ERROR" appears on the display.	Try the operation again. If "ERROR" appears again, check if the device supports the function you have tried.
"PLEASE WAIT" appears on the display.	The unit is preparing to use the Bluetooth function. If the message does not disappear, turn off and turn on the unit, then connect the device again (or reset the unit). (☞ page 3)
"HW ERROR" appears on the display.	Reset the unit and try the operation again. If "HW ERROR" appears again, consult your nearest JVC car audio dealer.
"BT DEVICE NOT FOUND" appears on the display.	<ul style="list-style-type: none"> • The unit failed to search for the registered Bluetooth devices during Auto Connect. Turn on Bluetooth from your device and connect manually.

Specifications

AUDIO AMPLIFIER SECTION

Power Output	20 W RMS x 4 Channels at 4Ω and ≤ 1% THD+N	
Load Impedance	4Ω (4Ω to 8Ω allowance)	
Frequency Response	40 Hz to 20 000 Hz	
Signal-to-Noise Ratio	80 dBA (reference: 1 W into 4Ω)	
Line-Out, Subwoofer-Out Level/Impedance	2.5 V/20 kΩ load (full scale)	
Output Impedance	≤ 600Ω	

TUNER SECTION

FM	Frequency Range	200 kHz step: 87.9 MHz to 107.9 MHz 50 kHz step: 87.5 MHz to 108.0 MHz
	Usable Sensitivity	9.3 dBf (0.8 μV/75Ω)
	50 dB Quieting Sensitivity	16.3 dBf (1.8 μV/75Ω)
	Alternate Channel Selectivity (400 kHz)	65 dB
	Frequency Response	40 Hz to 15 000 Hz
	Stereo Separation	40 dB
AM	Frequency Range	10 kHz step: 530 kHz to 1 700 kHz 9 kHz step: 531 kHz to 1 611 kHz
	Sensitivity/Selectivity	20 μV/40 dB

CD PLAYER SECTION

Signal Detection System	Non-contact optical pickup (semiconductor laser)
Number of Channels	2 channels (stereo)
Frequency Response	5 Hz to 20 000 Hz
Signal-to-Noise Ratio	98 dB
Wow and Flutter	Less than measurable limit

USB SECTION

USB Standard	USB 1.1, USB 2.0
Data Transfer Rate (Full Speed)	Max. 12 Mbps
Compatible Device	Mass storage class
Compatible File System	FAT 32/16/12
Playable Audio Format	MP3/WMA/WAV
Maximum Supply Current	DC 5 V = 1 A

BLUETOOTH SECTION

Version	Bluetooth 2.1 certified (+EDR)
Power Class	Class 2 Radio
Service Area	10 m (10.9 yd)
Profile	HFP 1.5, OPP 1.1, A2DP 1.2, AVRCP 1.3, PBAP 1.0

GENERAL

Power Requirement (Operating Voltage)		DC 14.4 V (11 V to 16 V allowance)
Grounding System		Negative ground
Allowable Operating Temperature		0°C to +40°C (32°F to 104°F)
Dimensions (W × H × D) (approx.)	Installation Size	182 mm × 111 mm × 160 mm (7-3/16" × 4-3/8" × 6-5/16")
	Panel Size	188 mm × 117 mm × 18 mm (7-7/16" × 4-5/8" × 3/4")
Mass		1.8 kg (4 lbs) (excluding accessories)

Subject to changes without notice.

If a kit is necessary for your car, consult your telephone directory for the nearest car audio speciality shop.



Having TROUBLE with operation?

Please reset your unit

Refer to page of How to reset your unit

Still having trouble??

USA ONLY

Call 1-800-252-5722

<http://www.jvc.com>

We can help you!

JVC

 EN, SP, FR

© 2011 JVC KENWOOD Corporation

1211DTSSANJEIN

JVC KW-R800BT

Installation/Connection Manual

Manual de instalación/conexión

Manuel d'installation/raccordement

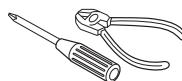

GET0792-002A
[J]

1211DTSSANJEIN
EN, SP, FR
© 2011 JVC KENWOOD Corporation

ENGLISH / ESPAÑOL / FRANÇAIS

WARNINGS / ADVERTENCIAS / AVERTISSEMENTS

- Mounting and wiring this product requires skills and experience. For safety's sake, leave this work to professionals. If you experience problems during installation, consult your JVC car audio dealer.
- The unit can only be installed in a car with a 12 V DC power supply, negative ground.
- Disconnect the battery's negative terminal and make all electrical connections before installing the unit.
- Connect speakers with a maximum power of more than 50 W (impedance of 4 Ω to 8 Ω). Otherwise, change the <AMP GAIN> setting. (See page 24 of the INSTRUCTIONS.)
- Insulate unconnected wires with vinyl tape or other similar material. To prevent a short circuit, do not remove the caps on the ends of the unconnected wires or the terminals.
- If the fuse blows, first make sure the wires are not touching to cause a short circuit, then replace the old fuse with one that has the same rating.
- Install this unit in the console of your vehicle.
- Mount the unit so that the mounting angle is 30° or less.
- Be sure to ground this unit to the car's chassis again after installation.
- After the unit is installed, check whether the brake lamps, blinkers, wipers, etc. on the car are working properly.
- Do not touch the metal part of this unit during and shortly after the use of the unit. Metal part such as the heat sink and enclosure become hot.
- La instalación y cableado de este producto requiere de habilidad y experiencia. Por motivos de seguridad, deja la labor de instalación y montaje en manos de profesionales. Si experimenta problemas durante la instalación, póngase en contacto con su distribuidor de equipos de audio para automóvil JVC.
- La unidad puede instalarse solamente en un automóvil con fuente de alimentación de 12 V CC, negativo a masa.
- Desconecte el terminal negativo de la batería y realice todas las conexiones eléctricas antes de instalar la unidad.
- Conecte los altavoces con una potencia máxima de más de 50 W (impedancia de 4 Ω a 8 Ω). De lo contrario, cambie el ajuste <AMP GAIN>. (Véase la página 24 del MANUAL DE INSTRUCCIONES.)
- Aísle los cables no conectados con cinta de vinilo u otro material similar. Para prevenir los cortocircuitos, no quite las tapas de los extremos de los cables o terminales no conectados.
- Si se funde un fusible, asegúrese primero de que los cables no estén en contacto pues pueden ocasionar un cortocircuito, luego reemplace el fusible dañados por otro de las mismas características.
- Instale esta unidad en la consola de su vehículo.
- Instale la unidad en un ángulo de montaje de 30° o menos.
- Asegúrese de volver a conectar a masa esta unidad al chasis del automóvil después de la instalación.
- Después de haber instalado la unidad, compruebe que las luces de freno, los intermitentes, los limpiaparabrisas, etc. del automóvil funcionan correctamente.
- No toque la parte metálica de esta unidad durante e inmediatamente después de usar la unidad. Las partes metálicas tal como el disipador de calor y la carcasa estarán calientes.
- Le montage et le câblage de ce produit nécessitent des compétences et de l'expérience. Pour des raisons de sécurité, laissez un professionnel effectuer le travail de montage et de câblage. Si vous rencontrez des problèmes durant l'installation, consultez votre revendeur d'autoradio JVC.
- L'appareil peut uniquement être installé dans une voiture avec une alimentation de 12 V CC, à masse négative.
- Déconnectez la borne négative de la batterie et réalisez toutes les connexions avant d'installer l'appareil.
- Connectez des enceintes avec une puissance maximum de 50 W (impédance de 4 Ω à 8 Ω). Sinon, changez le réglage <AMP GAIN>. (Voir la page 24 du MANUEL D'INSTRUCTIONS.)
- Isolez les câbles non-connectés avec un ruban de vinyle ou d'un autre matériel similaire. Pour éviter les courts-circuits, ne retirez pas non plus les capuchons à l'extrémité des câbles non-connectés ou des prises.
- Si un fusible saute, assurez-vous d'abord que les câbles n'ont pas causé de court-circuit puis remplacez le vieux fusible par un nouveau de même valeur.
- Installez cet appareil dans la consola de votre véhicule.
- Monter l'unité de façon à ce que l'angle de montage soit de 30° ou moins.
- Assurez-vous de raccorder de nouveau la mise à la masse de cet appareil au châssis de la voiture après l'installation.
- Après avoir installé l'appareil, vérifiez si les lampes de frein, les indicateurs, les clignotants, etc. de la voiture fonctionnent correctement.
- Ne touchez pas la partie métallique de cet appareil pendant ou juste après son utilisation. Les parties métalliques, comme le dissipateur de chaleur et le boîtier, deviennent chaudes.

PRECAUTIONS on power supply and speaker connections

- DO NOT connect the speaker leads of the power cord to the car battery; otherwise, the unit will be seriously damaged.
- BEFORE connecting the speaker leads of the power cord to the speakers, check the speaker wiring in your car.
- Connect the speaker wires correctly to the terminals to which they correspond. The unit may damaged or fail to work if you share the ⊖ wires or ground them to any metal part in the car.

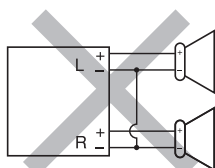

PRECAUCIONES sobre las conexiones de la fuente de alimentación y de los altavoces

- NO conecte los conductores de altavoz del cable de alimentación a la batería de automóvil, pues podrían producirse graves daños en la unidad.
- ANTES de conectar a los altavoces los conductores de altavoz del cable de alimentación, verifique el conexionado de altavoz de su automóvil.
- Conecte los cables del altavoz correctamente con los terminales que correspondan. La unidad puede estropearse o averiarse si se conectan entre sí los cables ⊖ o los conecta a tierra con la carrocería del coche.

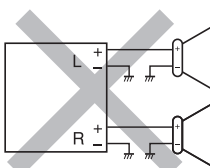

PRECAUTIONS sur l'alimentation et la connexion des enceintes

- NE CONNECTEZ PAS les fils d'enceintes du cordon d'alimentation à la batterie; sinon, l'appareil serait sérieusement endommagé.
- AVANT de connecter les fils d'enceintes du cordon d'alimentation aux enceintes, vérifiez le câblage des enceintes de votre voiture.
- Veillez à brancher correctement les câbles des enceintes aux prises correspondantes. L'appareil risquerait d'être endommagé ou de mal fonctionner si les câbles ⊖ ne sont pas raccordés séparément ou s'ils sont raccordés à la carrosserie métallique de la voiture.

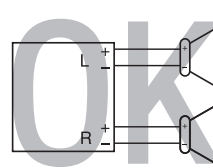

Part list

Ⓐ Sleeve (fitted to the main unit when shipped)(x1)
Ⓑ Brackets (fitted to the main unit when shipped)(x2)
Ⓒ* Flat countersunk screws—M5 × 8 mm (3/8")(x8)
Ⓓ* Round head screws—M2.6 × 3 mm (1/8")(x4)
Ⓔ Round head screws—M5 × 8 mm (3/8")(x8)
Ⓕ Power cord(x1)
Ⓖ Trim plate(x1)
Ⓗ Microphone(x1)
① KS-UBT1: USB Bluetooth adapter(x1)

* Four of these screws are fitted to the main unit when shipped. Keep these screws for installation use if necessary.

Lista de componentes

Ⓐ Manguito (fijado a la unidad principal cuando se expide de fábrica)(x1)
Ⓑ Soportes (fijados a la unidad principal cuando se expide de fábrica)(x2)
Ⓒ* Tornillos de cabeza avellanada plana—M5 × 8 mm (3/8 pulgada)(x8)
Ⓓ* Tornillos de cabeza esférica—M2,6 × 3 mm (1/8 pulgada)(x4)
Ⓔ Tornillos de cabeza esférica—M5 × 8 mm (3/8 pulgada)(x8)
Ⓕ Cordon de alimentación(x1)
Ⓖ Placa de guarnición(x1)
Ⓗ Micrófono(x1)
① KS-UBT1: Adaptador Bluetooth USB(x1)

* Cuatro de los tornillos vienen de fábrica fijados a la unidad principal. Guarde estos tornillos para utilizar en la instalación, si fuera necesario.

Liste de pièces

Ⓐ Manchon (fixé à l'appareil lors de l'expédition)(x1)
Ⓑ Supports (fixés à l'appareil lors de l'expédition)(x2)
Ⓒ* Vis plat à tête fraisée—M5 × 8 mm (3/8 pouces)(x8)
Ⓓ* Vis à tête ronde—M2,6 × 3 mm (1/8 pouces)(x4)
Ⓔ Vis à tête ronde—M5 × 8 mm (3/8 pouces)(x8)
Ⓕ Cordon d'alimentation(x1)
Ⓖ laque d'assemblage(x1)
Ⓗ Microphone(x1)
① KS-UBT1: Adaptateur USB Bluetooth(x1)

* Quatre de ces vis sont fixées sur l'appareil au moment de l'expédition. Conservez ces vis pour les utiliser si nécessaire pour une installation.

INSTALLATION / INSTALACIÓN / INSTALLATION

The following illustration shows a typical installation. If you have any questions or require information regarding installation kits, consult your JVC car audio dealer or a company supplying kits.

La siguiente ilustración muestra una instalación típica. Si tiene alguna pregunta o necesita información acerca de las herramientas para instalación, consulte con su concesionario de JVC de equipos de audio para automóviles o a una compañía que suministra tales herramientas.

L'illustration suivante est un exemple d'installation typique. Si vous avez des questions ou avez besoin d'information sur des kits d'installation, consulter votre revendeur d'autoradios JVC ou une compagnie d'approvisionnement.

In-dash mounting / Montaje en el tablero / Montage encastré

(A) Installing with the supplied sleeve / Instalación con el manguito suministrado / Installation avec le manchon fourni

1 Audio system originally installed in the car / Sistema de audio instalado originalmente en el vehículo / Système audio installé à l'origine dans la voiture

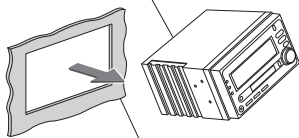

Car dashboard / Cubretablero del automóvil / Tableau de bord de la voiture

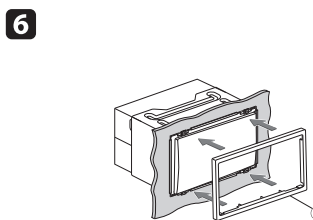
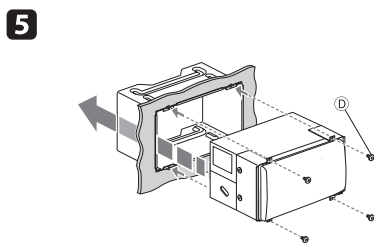
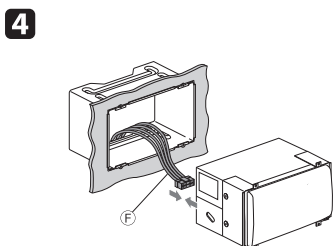
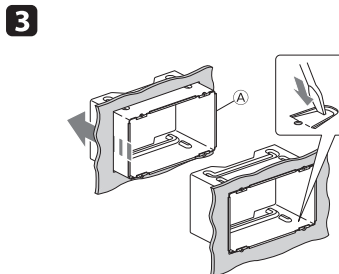
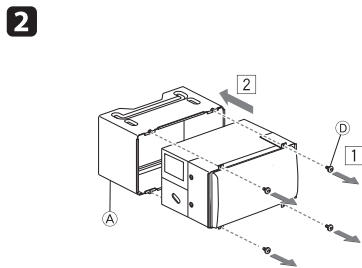

(B) Installing with the mounting brackets from the car / Instalación con los soportes de montaje desde el automóvil / Installation avec les supports de montage de la voiture

1 Audio system originally installed in the car / Sistema de audio instalado originalmente en el vehículo / Système audio installé à l'origine dans la voiture

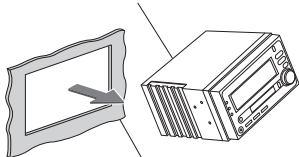

Car dashboard / Cubretablero del automóvil / Tableau de bord de la voiture

3 Firmly attach the ground wire to the metallic body of the car using the screw originally fixed to the metallic body of the car. / Conecte firmemente el cable de tierra a la carrocería metálica del automóvil mediante el tornillo instalado originalmente en la misma. / Fixez solidement le fil de mise à la masse au châssis métallique de la voiture en utilisant une vis fixée à l'origine au châssis métallique de la voiture.

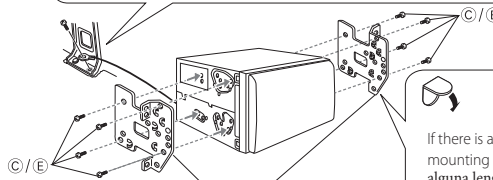

Mounting bracket removed from the car / Soporte de montaje removido del automóvil / Support de montage retiré de la voiture

If there is an interfering tab on the mounting bracket, bend it flat. / Si hay alguna lengüeta que interfiere con el soporte de montaje, dóblela hasta que quede plana. / S'il y a une languette gênante sur le support de montage, aplatissez-la.

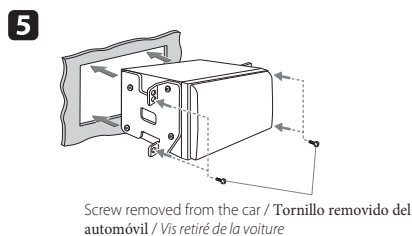
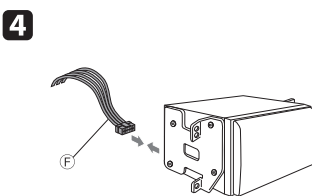
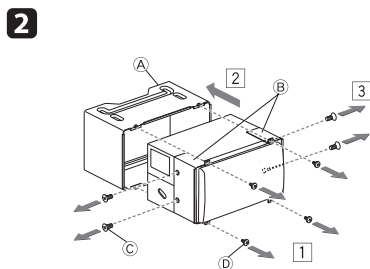

Screw removed from the car / Tornillo removido del automóvil / Vis retiré de la voiture

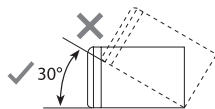

Install the unit at an angle of less than 30°. / Instale la unidad a un ángulo de menos de 30°. / Installez l'appareil avec un angle de moins de 30°.

ELECTRICAL CONNECTIONS / CONEXIONES ELECTRICAS / RACCORDEMENTS ELECTRIQUES

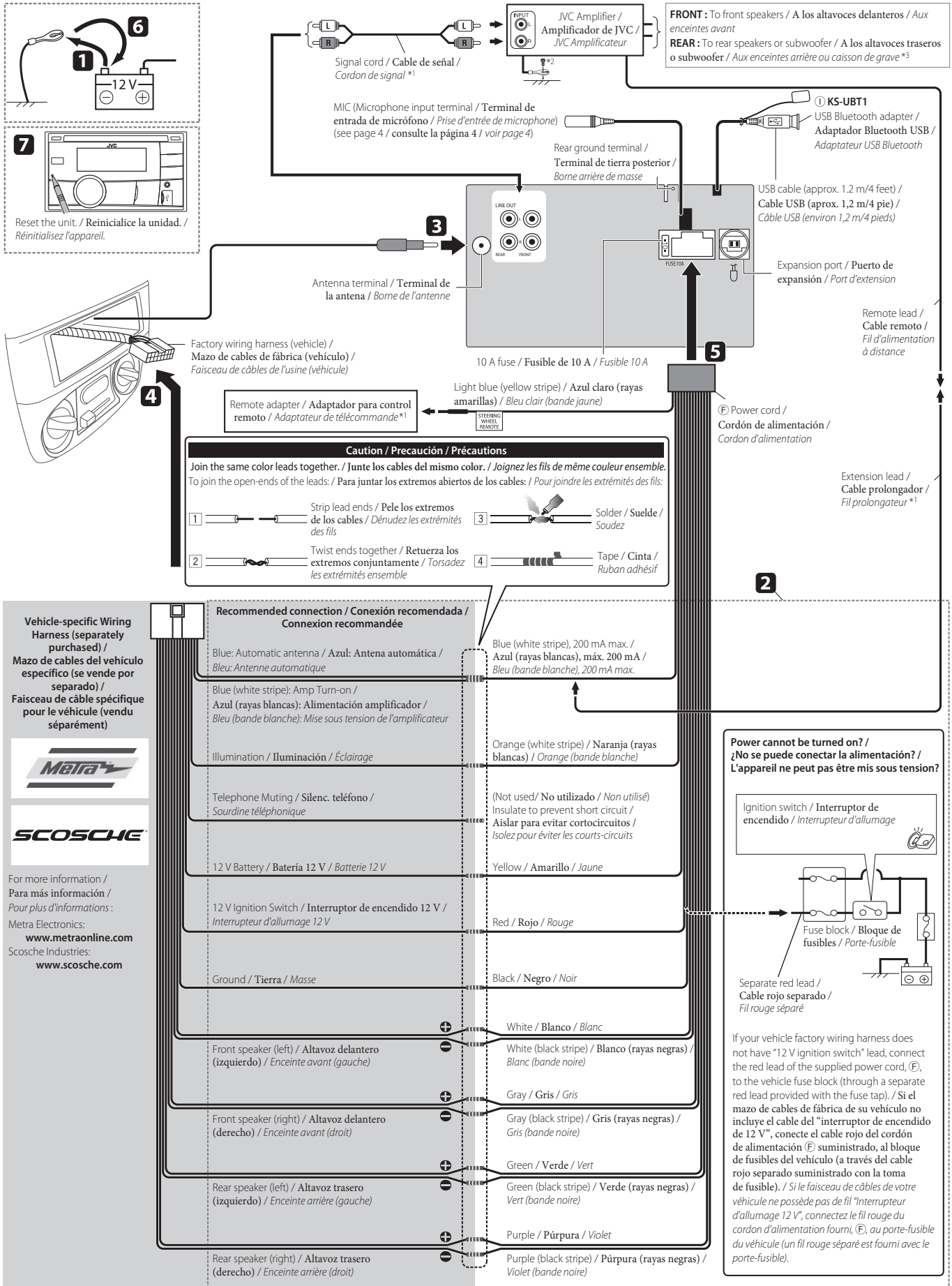

*1 Not supplied for this unit.

*2 Firmly attach the ground wire to the metallic body or to the chassis of the car—to the place uncoated with paint.

*3 Make the <L/O MODE> setting accordingly, see page 24 of the INSTRUCTIONS.

*1 No suministrado con esta unidad.

*2 Fije firmemente el cable de tierra a la carrocería metálica o al chasis—a un lugar no cubierto con pintura.

*3 Realice el ajuste <L/O MODE> de conformidad, consulte la página 24 del MANUAL DE INSTRUCCIONES.

*1 Non fourni avec cet appareil.

*2 Attachez solidement le fil de mise à la masse au châssis métallique de la voiture—a un endroit qui n'est pas recouvert de peinture.

*3 Réalisez le réglage <L/O MODE> en fonction, voir page 24 du MANUEL D'INSTRUCTIONS.

Connecting the microphone unit / Conexión de la unidad de micrófono / Connexion du microphone

Secure using cord clamps*1 if necessary. /
Si es necesario, asegure por medio de las abrazaderas*1 /
Fixez en utilisant des serre-fils*1 si nécessaire

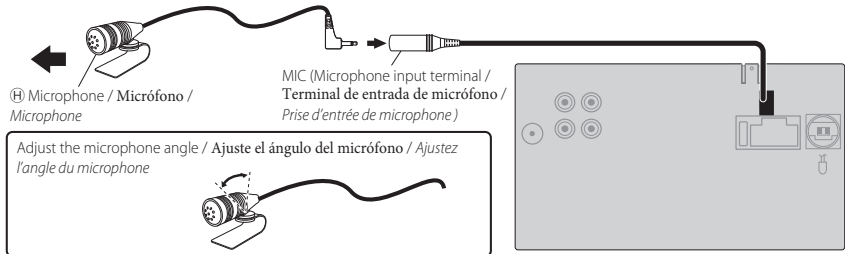

Connecting the external components in series / Conexión de componentes externos en serie / Connexion d'appareils extérieurs en série

When connecting the external components, refer also to the manuals supplied for the components and adapter.

Cuando conecte componentes externos, consulte, también, los manuales suministrados con los componentes y el adaptador.

Lors de la connexion des appareils extérieurs, référez-vous aussi aux manuels fournis avec les appareils et les adaptateurs.

Caution:

Before connecting the external components, make sure that the unit is turned off.

Precaución:

Antes de conectar los componentes externos, asegúrese de que la unidad esté apagada.

Precaution:

Avant de connecter les appareils extérieurs, assurez-vous que l'appareil est hors tension.

Expansion port of the unit / Puerto de expansión de la unidad / Port d'extension de l'appareil

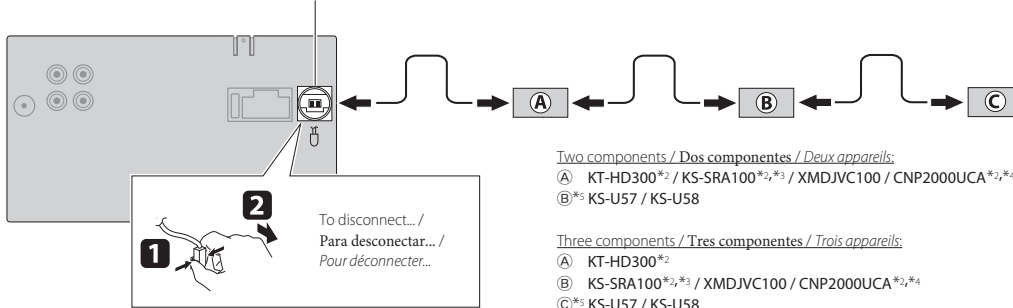

Two components / Dos componentes / Deux appareils:

- Ⓐ KT-HD300*2 / KS-SRA100*2,*3 / XMDJVC100 / CNP2000UCA*2,*4
- Ⓑ*3 KS-U57 / KS-U58

Three components / Tres componentes / Trois appareils:

- Ⓐ KT-HD300*2
- Ⓑ KS-SRA100*2,*3 / XMDJVC100 / CNP2000UCA*2,*4
- Ⓒ*3 KS-U57 / KS-U58

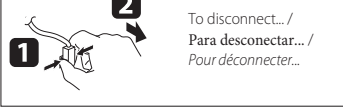

To disconnect... /
Para desconectar... /
Pour déconnecter...

You can connect the HD Radio™ tuner box (KT-HD300) or the following components through the various JVC adapters or system to the expansion port.

- Connection cords may need to be purchased separately.

Puede conectar el sintonizador HD Radio™ (KT-HD300) o los siguientes componentes al puerto de expansión, a través de los diversos adaptadores o sistema JVC.

- Puede ser necesario comprar los cables de conexión por separado.

Vous pouvez connecter le tuner HD Radio™ (KT-HD300) ou les appareils suivants à l'aide de divers adaptateur JVC ou système au port d'extension.

- Vous pouvez avoir besoin d'acheter certains cordons de connexion séparément.

Component / Componente / Appareil	Adapter/System / Adaptador/Sistema / Adaptateur/Système	Model name / Nombre del modelo / Nom du modèle
XMDirect2 Tuner System / Sistema de sintonizador XMDirect2 / XMDirect2 Tuner System	XM Satellite Radio System / Sistema de radio XM Satellite / Système radio satellite XM	CNP2000UCA, CNPJVC1
SIRIUS Satellite Radio / Radio por satélite SIRIUS / Radio satellite SIRIUS	SIRIUS Satellite Radio System / Sistema de radio satelital SIRIUS / Système radio satellite SIRIUS	SCC1, KS-SRA100 D&P, SCVDOC1, KS-SRA100
Portable audio player with line output jacks / Reproductor de audio portátil con jacks de salida de línea / Lecteur audio portable avec prises de sortie de ligne	Line input adapter / Adaptador de entrada por línea / Adaptateur d'entrée de ligne	KS-U57
Portable audio player with 3.5 mm (1/8") stereo mini jack / Reproductor de audio portátil con jack mini estéreo de 3,5 mm (1/8 pulgada) / Lecteur audio portable avec mini fiche stéréo de 3,5 mm (1/8 pouces)	AUX input adapter / Adaptador de entrada AUX / Adaptateur d'entrée auxiliaire	KS-U58

XM Radio and SIRIUS Satellite Radio cannot be used together.

No puede utilizar juntas la radio XM y la radio satelital SIRIUS.

La radio XM et SIRIUS ne peuvent pas être utilisées en même temps.

*1 Not supplied for this unit.

*2 Connect the power cord supplied for the component separately for power supply.

*3 This model is a component of SIRIUS Satellite Radio System.

*4 This model is a component of XM Satellite Radio System.

*5 To use these components, set the external input setting correctly (see page 25 of the INSTRUCTIONS).

*1 No suministrado con esta unidad.

*2 Conecte el cable de alimentación suministrado separadamente para el componente.

*3 Este modelo es un componente del sistema de radio satelital SIRIUS.

*4 Este modelo es un componente del sistema de radio XM Satellite.

*5 Para utilizar estos componentes, configure el ajuste de entrada externa correctamente (consulte la página 25 del MANUAL DE INSTRUCCIONES).

*1 Non fourni avec cet appareil.

*2 Connectez le cordon d'alimentation fourni avec les appareils séparément à l'alimentation.

*3 Ce modèle est un composant du système radio satellite SIRIUS.

*4 Ce modèle est un composant du système radio satellite XM.

*5 Pour utiliser ces appareils, réglez l'entrée extérieure correctement (voir page 25 du MANUEL D'INSTRUCTIONS).

TROUBLESHOOTING / LOCALIZACION DE AVERIAS / EN CAS DE DIFFICULTES

- **The fuse blows.** ⇒ Are the red and black leads connected correctly?
- **Power cannot be turned on.** ⇒ Is the yellow lead connected?
- **No sound from the speakers.** ⇒ Is the speaker output lead short-circuited?
- **"MISWIRING CHK WIRING THEN RESET UNIT" / "WARNING CHK WIRING THEN RESET UNIT" appears on the display and no operation can be done.** ⇒ Is the speaker output lead short-circuited or touches the chassis of the car/head unit?; Have you reset your unit?
- **Sound is distorted.** ⇒ Is the speaker output lead grounded?; Are the "-" terminals of L and R speakers grounded in common?
- **Noise interferes with sounds.** ⇒ Is the rear ground terminal connected to the car's chassis using shorter and thicker cords?
- **This unit becomes hot.** ⇒ Is the speaker output lead grounded?; Are the "-" terminals of L and R speakers grounded in common?
- **This unit does not work at all.** ⇒ Have you reset your unit?

- **El fusible se quema.** ⇒ ¿Están los conductores rojo y negro correctamente conectados?
- **No es posible conectar la alimentación.** ⇒ ¿Está el cable amarillo conectado?
- **No sale sonido de los altavoces.** ⇒ ¿Está el cable de salida del altavoz cortocircuitado?
- **Aparece "MISWIRING CHK WIRING THEN RESET UNIT" / "WARNING CHK WIRING THEN RESET UNIT" en la pantalla y no se puede realizar ninguna operación.** ⇒ ¿El conductor de salida de altavoz está en cortocircuito o en contacto con el chasis del automóvil/auriculares?; ¿Reinicializó la unidad?
- **El sonido presenta distorsión.** ⇒ ¿Está el cable de salida del altavoz conectado a masa?; ¿Están los terminales "-" de los altavoces L y R conectados a una masa común?
- **Perturbación de ruido.** ⇒ ¿El terminal de tierra trasero está conectado al chasis del automóvil utilizando los cordones más corto y más grueso?
- **Esta unidad se calienta.** ⇒ ¿Está el cable de salida del altavoz conectado a masa?; ¿Están los terminales "-" de los altavoces L y R conectados a una masa común?
- **Esta unidad no funciona en absoluto.** ⇒ ¿Reinicializó la unidad?

- **Le fusible saute.** ⇒ Les fils rouge et noir sont-ils raccordés correctement?
- **L'appareil ne peut pas être mise sous tension.** ⇒ Le fil jaune est-elle raccordée?
- **Pas de son des enceintes.** ⇒ Le fil de sortie d'enceinte est-il court-circuité?
- **"MISWIRING CHK WIRING THEN RESET UNIT" / "WARNING CHK WIRING THEN RESET UNIT" apparaît sur l'affichage et aucune opération ne peut être réalisée.** ⇒ Est-ce qu'un fil de sortie d'enceinte est court-circuité ou touche le châssis de la voiture/appareil principal?; Avez-vous réinitialisé votre appareil?
- **Le son est déformé.** ⇒ Le fil de sortie d'enceinte est-il à la masse?; Les bornes "-" des enceintes gauche et droit sont-elles mises ensemble à la masse?
- **Interférence avec les sons.** ⇒ La prise arrière de mise à la terre est-elle connectée au châssis de la voiture avec un cordon court et épais?
- **Cet appareil devient chaud.** ⇒ Le fil de sortie d'enceinte est-il à la masse?; Les bornes "-" des enceintes gauche et droit sont-elles mises ensemble à la masse?
- **Cet appareil ne fonctionne pas du tout.** ⇒ Avez-vous réinitialisé votre appareil?



CAUTION

To use the Bluetooth Function, connect the supplied USB Bluetooth Adapter (KS-UBT1) to either one of the USB input terminals of the unit.

Front USB Port

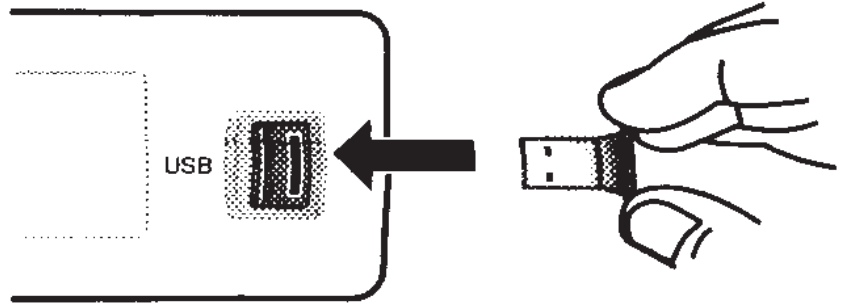

or

Rear USB Cable

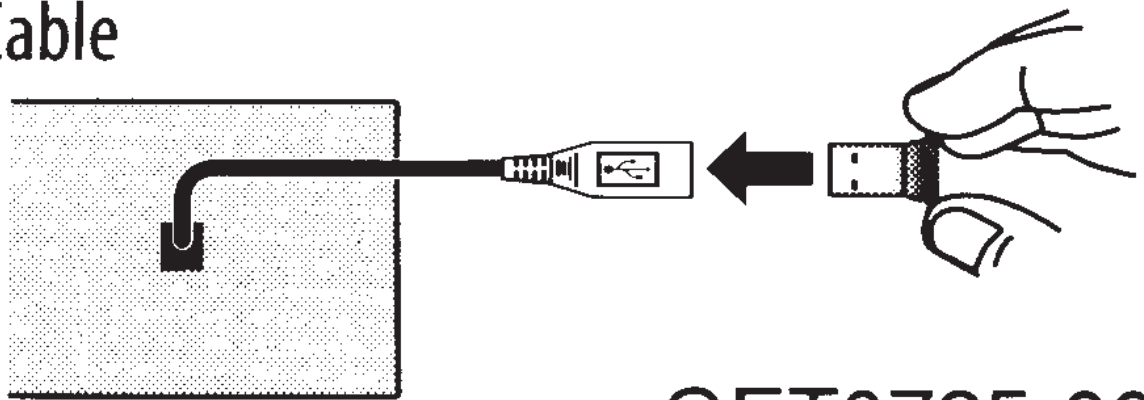

GET0725-001A

JVC

KS-UBT1



USB Bluetooth Adapter / Adaptateur USB Bluetooth / Adaptador Bluetooth USB / USB-Bluetooth-Adapter / Adattatore USB per Bluetooth / Adaptador USB de Bluetooth / USB Bluetooth adapter / USB Bluetooth-adapter / USB-Bluetooth-adapter / USB Bluetooth -sovitin / USB Bluetooth Adaptör / USB-адаптер Bluetooth / Προσαρμογέας Bluetooth USB / Adapter Bluetooth USB / USB Bluetooth adaptér / USB Bluetooth Adapter / Bluetooth-адаптер USB / Adaptor USB Bluetooth / USB Bluetooth адаптер / Bluetooth-адаптер USB / USB Bluetooth 어댑터 / USB 藍牙轉換器 / USB محول البلوتوث عبر / USB Bluetooth адаптор / Adaptor Bluetooth USB

INSTRUCTIONS / MANUEL D'INSTRUCTIONS / MANUAL DE INSTRUCCIONES / BEDIENUNGSANLEITUNG / ISTRUZIONI / INSTRUÇÕES / GEBRUIKSAANWIJZING / BRUKSANVISNING / INSTRUKTIONSBOG / KÄYTTÖOHJE / TALÍMATLAR / ИНСТРУКЦИИ ПО ЭКСПЛУАТАЦИИ / ΟΔΗΓΙΕΣ / INSTRUKCJA OBSŁUGI / PRÍRUČKA K OBSLUZE / HASZNÁLATI UTASÍTÁSA / ІНСТРУКЦІЇ / INSTRUȚIUNI / ИНСТРУКЦИИ / คำแนะนำ / 사용 설명서 / 使用説明書 / دليل التعليمات / دستور العمل ها / BUKU PETUNJUK

EN, FR, SP, GE, IT, PR, NL, SW, DA, FI, TR, RU, GR, PO, CZ, HU, UK, RO, BU, TH, KO, CT, AR, PE, IN GET0617-001H [K]

English:

A copy of the Declaration of Conformity with regard to the R&TTE Directive 1999/5/EC can be downloaded from the following Web sites
(<http://www3.jvckenwood.com/ecdoc/>).
[CE0984]

Hereby, JVC KENWOOD declares that this unit [KS-UBT1] is in compliance with the essential requirements and other relevant provision of Directive 1999/5/EC.

Français:

Une copie de la Déclaration de Conformité relative à la Directive R&TTE 1999/5/CE peut être téléchargée à partir des sites Web suivants (<http://www3.jvckenwood.com/ecdoc/>).
[CE0984]

Par la présente, JVC KENWOOD déclare que cet appareil [KS-UBT1] est conforme aux exigences essentielles et aux autres dispositions pertinentes de la Directive 1999/5/CE.

Español:

Puede descargarse una copia de la Declaración de conformidad relacionada con la Directiva 1999/5/CE (equipos radioeléctricos y equipos terminales de telecomunicación) en los siguientes sitios web (<http://www3.jvckenwood.com/ecdoc/>).
[CE0984]

Por la presente, JVC KENWOOD declara que esta unidad [KS-UBT1] cumple con los requisitos fundamentales y otras disposiciones pertinentes previstos en la Directiva 1999/5/CE.

Deutsch:

Eine Kopie der Übereinstimmungserklärung bezüglich der R&TTE-Richtlinie 1999/5/EG kann von den folgenden Websites heruntergeladen werden (<http://www3.jvckenwood.com/ecdoc/>).
[CE0984]

JVC KENWOOD erklärt hiermit, dass dieses Gerät [KS-UBT1] den wesentlichen Anforderungen und anderen relevanten Bestimmungen der Richtlinie 1999/5/EG entspricht.

Italiano:

Copia della Dichiarazione di Conformità alla Direttiva R&TTE 1999/5/CE può essere scaricata dai seguenti siti Web (<http://www3.jvckenwood.com/ecdoc/>).
[CE0984]

Con la presente JVC KENWOOD dichiara che questa unità [KS-UBT1] è conforme ai requisiti essenziali ed alle altre disposizioni pertinenti stabilite dalla direttiva 1999/5/CE.

Português:

É possível transferir uma cópia da Declaração de Conformidade relativa à Directiva R&TTE (1999/5/CE) a partir dos sítios Web seguintes
(<http://www3.jvckenwood.com/ecdoc/>).
[CE0984]

A JVC KENWOOD declara que esta unidade [KS-UBT1] está em conformidade com os requisitos essenciais e outras disposições relevantes da Directiva 1999/5/CE.

Nederlands:

Een kopie van de conformiteitsverklaring met betrekking tot de R&TTE-richtlijn 1999/5/EG kan worden gedownload van de volgende websites
(<http://www3.jvckenwood.com/ecdoc/>).
[CE0984]

Hierbij verklaart JVC KENWOOD dat dit apparaat [KS-UBT1] voldoet aan de essentiële vereisten en andere relevante bepalingen van richtlijn 1999/5/EG.

Svenska:

En kopia av deklarationen om överensstämmelse med R&TTE-direktivet 1999/5/EG kan hämtas på följande webbplatser (<http://www3.jvckenwood.com/ecdoc/>).
[CE0984]

Härmed intygar JVC KENWOOD att denna enhet [KS-UBT1] står i överensstämmelse med de väsentliga egenskapskrav och övriga relevanta bestämmelser som framgår av direktiv 1999/5/EG.

Danski:

Et eksemplar af Overensstemmelseserklæringen med henvisning til R&TTE-direktivet 1999/5/EF kan hentes fra følgende websteder (<http://www3.jvckenwood.com/ecdoc/>).
[CE0984]

JVC KENWOOD erklærer herved, at denne enhed [KS-UBT1] er i overensstemmelse med de væsentlige krav og andre relevante bestemmelser i direktiv 1999/5/EF.

Suomi:

Vaatumusten mukaisuusvakuutuksen radio- ja telepäätelaitteita (R&TTE) koskeva direktiivi 1999/5/EY voidaan ladata seuraavista verkko-osoitteista (<http://www3.jvckenwood.com/ecdoc/>).
[CE0984]

JVC KENWOOD vakuuttaa täten, että [KS-UBT1]-laitte on direktiivin 1999/5/EY oleellisten vaatimusten ja sitä koskevien direktiivin muiden ehtojen mukainen.

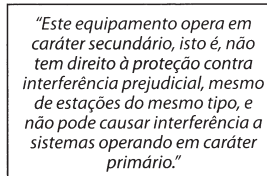
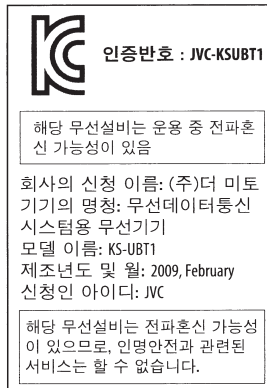
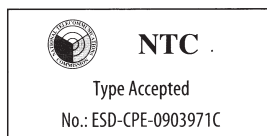

N49

Approved by TRA

Complies with
IDA Standards
DB102150

MTC:OFICIO No 8396-2008-MTC/29

CONATEL certificate No: 001516

SUBTEL: 30234/DFRS00045/F-49

"This telecommunication equipment conforms to NTC technical requirement"

13973/POSTEL/2010
2366

TEC/WR/I/MOD-08/02/135.APR 08

URSEC 365/FR/2010

Distributor name: JVC KENWOOD DO BRASIL
COMERCIO DE ELETROELECTRONICS LTDA
CNPJ of distributor: JVC KENWOOD DO BRASIL
COMERCIO DE ELETROELECTRONICS LTDA
Manufacturer: JVC KENWOOD Corporation
Model no.: KS-UBT1
Brand: JVC

ANATEL

0178-11-6733

(01)07898929117502

Türkçe:

R&TTE Direktifi 1999/5/EC ile ilgili Uygunluk Beyanı'nın bir kopyası aşağıdaki web sitelerinden indirilebilir.
(<http://www3.jvckenwood.com/ecdoc/>)
[CE0984]

Burada, JVC KENWOOD, bu üniteyi [KS-UBT1] 1999/5/EC'nin vazeğilmez gereksinimleri ve diğer ilgili hükümleri ile uyumlu olduğunu beyan eder.

Ελληνική:

Ένα αντίγραφο της Δήλωσης συμμόρφωσης με την Οδηγία 1999/5/ΕΚ σχετικά με το ραδιοεξοπλισμό και τον τηλεπικοινωνιακό τεμαχικό εξοπλισμό μπορεί να ληφθεί από τις παρακάτω τοποθεσίες στο Web (<http://www3.jvckenwood.com/ecdoc/>).
[CE0984]

Δια του παρόντος, η JVC KENWOOD δηλώνει ότι αυτή η μονάδα [KS-UBT1] συμμορφώνεται προς τις ουσιαστικές απαιτήσεις και τις λοιπές σχετικές διατάξεις της Οδηγίας 1999/5/ΕΚ.

Polski:

Kopię deklaracji zgodności z Dyrektywą 1999/5/EC można pobrać z następujących stron internetowych
(<http://www3.jvckenwood.com/ecdoc/>).
[CE0984]

Niniejszym firma JVC KENWOOD oświadcza, że niniejsze urządzenie [KS-UBT1] jest zgodne z zasadniczymi wymogami i pozostawia stosownymi postanowieniami Dyrektywy 1999/5/EC.

Cesky:

Kopii Prohlášení o shodě s požadavky směrnice R&TTE 1999/5/ES lze stáhnout z následujících webových stránek (<http://www3.jvckenwood.com/ecdoc/>).
[CE0984]

JVC KENWOOD tímto prohlašuje, že tento [KS-UBT1] je ve shodě se základními požadavky a dalšími příslušnými ustanoveními směrnice 1999/5/ES.

Magyar:

Az 1999/5/EC jelű R&TTE irányelvhez kapcsolódó Megfelelőségi nyilatkozat példányát a következő webhelyekről tölthető le:
(<http://www3.jvckenwood.com/ecdoc/>)
[CE0984]

A JVC KENWOOD kijelenti, hogy a jelen eszköz [KS-UBT1] megfelel az 1999/5/EC jelű irányelv alapvető követelményeinek és egyéb vonatkozó rendelkezéseinek.

Română:

O copie a Declarației de conformitate referitoare la directiva R&TTE 1999/5/EC poate fi descărcată de pe următoarele situri web (<http://www3.jvckenwood.com/ecdoc/>).
[CE0984]

Prin prezenta, JVC KENWOOD declară că această unitate [KS-UBT1] respectă cerințele esențiale și alte prevederi importante ale directivei 1999/5/EC.

Български:

Копие от декларацията за съответствие по отношение на Директива 1999/5/ЕО относно R&TTE може да бъде изтеглено от следните уебсайтове
(<http://www3.jvckenwood.com/ecdoc/>).
[CE0984]

С настоящото JVC KENWOOD декларира, че това изделие [KS-UBT1] е в съответствие с основните изисквания и другите приложими разпоредби на Директива 1999/5/ЕО.

Declaration of Conformity with regard to the R&TTE Directive 1999/5/EC

Manufacturer: JVC KENWOOD Corporation
3-12 Moriyacho,
Kanagawa-ku, Yokohama-shi,
Kanagawa, 221-0022
Japan

EU Representative's: JVC Technical Services Europe GmbH
Postfach 10 05 04
61145 Friedberg
Germany



English:
Hereby, JVC KENWOOD, declares that this KS-UBT1 is in compliance with the essential requirements and other relevant provisions of Directive 1999/5/EC.

Deutsch:
Hiermit erkläre ich JVC KENWOOD, dass sich das Gerät KS-UBT1 in Übereinstimmung mit den grundlegenden Anforderungen und den übrigen einschlägigen Bestimmungen der Richtlinie 1999/5/EG befindet. Hiermit erkläre ich JVC KENWOOD die Übereinstimmung des Gerätes KS-UBT1 mit den grundlegenden Anforderungen und den anderen relevanten Festlegungen der Richtlinie 1999/5/EG befindet. (Wien)

Français:
Par la présente JVC KENWOOD déclare que l'appareil KS-UBT1 est conforme aux exigences essentielles et aux autres dispositions pertinentes de la directive 1999/5/CE.

Nederlands:
Hierbij verklaart JVC KENWOOD dat het toestel KS-UBT1 in overeenstemming is met de essentiële eisen en de andere relevante bepalingen van richtlijn 1999/5/EG.

Dansk:
Undertegnede JVC KENWOOD erklærer herved, at følgende udstyr KS-UBT1 overholder de væsentlige krav og øvrige relevante krav i direktiv 1999/5/EF

Español:
Por medio de la presente JVC KENWOOD declara que el KS-UBT1 cumple con los requisitos esenciales y cualesquiera otras disposiciones aplicables o exigibles de la Directiva 1999/5/CE

Ελληνικά:
ΜΕ ΤΗΝ ΠΑΡΟΥΣΑ JVC KENWOOD ΔΗΛΩΝΕΙ ΟΤΙ ΚΣ-UBT1 ΣΥΜΜΟΡΦΩΝΕΤΑΙ ΠΡΟΣ ΤΙΣ ΟΥΣΙΩΔΕΙΣ ΑΠΑΙΤΗΣΕΙΣ ΚΑΙ ΤΙΣ ΛΟΙΠΕΣ ΣΧΗΤΙΚΕΣ ΔΙΑΤΑΞΕΙΣ ΤΗΣ ΟΔΗΓΙΑΣ 1999/5/ΕΚ.

Italiano:
Con la presente JVC KENWOOD dichiara che questo KS-UBT1 è conforme ai requisiti essenziali ed alle altre disposizioni pertinenti stabilite dalla direttiva 1999/5/CE.

Malta:
Hawnhekk, JVC KENWOOD, jiddjkkara li dan KS-UBT1 jikkonforma mal-ftigijiet essenzzjali u ma provvedimenti oħrajn relevanti li hemm fid-Direttiva 1999/5/EC.

Portugués:
JVC KENWOOD declara que este KS-UBT1 está conforme com os requisitos essenciais e outras disposições da Directiva 1999/5/CE.

Suomi:
JVC KENWOOD vakuuttaa täten että KS-UBT1 tyyppinen laite on direktiivin 1999/5/EY oleellisten vaatimusten ja sitä koskevien direktiivin muiden ehtojen mukainen.

Svenska:
Härmed intygar JVC KENWOOD att denna KS-UBT1 står i överensstämmelse med de väsentliga egenskapskrav och övriga relevanta bestämmelser som framgår av direktiv 1999/5/EG.

Íslenska:
Hér með lýsir JVC KENWOOD yfir því að KS-UBT1 er í samræmi við grunnkröfur og aðrar kröfur, sem gerðar eru í tilskipun 1999/5/EC.

Norsk:
JVC KENWOOD erklærer herved at utstyret KS-UBT1 er i samsvar med de grunnleggende krav og øvrige relevante krav i direktiv 1999/5/EF.

Cesky:
JVC KENWOOD tímto prohlašuje, že tento KS-UBT1 je ve shodě se základními požadavky a dalšími příslušnými ustanoveními směrnice 1999/5/ES.

Eesti:
Käesolevaga kinnitab JVC KENWOOD seadme KS-UBT1 vastavust direktiivi 1999/5/EÜ põhinõuetele ja nimetatud direktiivist tulenevatele teistele asjakohastele sätetele.

Latviski:
Ar šo JVC KENWOOD deklare, ka KS-UBT1 atbilst Direktīvas 1999/5/ EK būtiskajām prasībām un citiem ar to saistītajiem noteikumiem.

Lietuviu:
Šiuo JVC KENWOOD deklaruoją, kad šis KS-UBT1 atitinka esminius reikalavimus ir kitas 1999/5/EB Direktyvos nuostatas.

Magyar:
Alulírott, JVC KENWOOD nyilatkozom, hogy a KS-UBT1 megfelel a vonatkozó alapvető követelményeknek és az 1999/5/EC irányelv egyéb előírásainak.

Polski:
Niniejszym JVC KENWOOD oświadczam, że KS-UBT1 jest zgodny z zasadniczymi wymogami oraz pozostałymi stosownymi postanowieniami Dyrektywy 1999/5/EC.

Slovensko:
JVC KENWOOD izjavlja, da je ta KS-UBT1 v skladu z bistvenimi zahtevami in ostalimi relevantnimi določili direktive 1999/5/ES.

Slovenski:
JVC KENWOOD tímto vyhlasuje, že KS-UBT1 splna základné požiadavky a všetky príslušné ustanovenia Smernice 1999/5/ES.

Română:
Prin aceasta, JVC KENWOOD, declară că acest KS-UBT1 este în conformitate cu prevederile generale și cu alte norme ale Directivei 1999/5/EC.

Български:
С настоящото JVC KENWOOD декларира, че izdelieto KS-UBT1 съответства на основните изисквания, както и на други приложими клаузи на Директива 1999/5/EC.

SPECIFICATIONS

- Bluetooth Version: Ver 2.1 +EDR
- Power Class: Class 2
- Service Area: 10 m (10.9 yd)
- USB Standards: USB V1.1 (Full Speed)

Power Consumption: 54.3 mA/5 V (max.)

Dimensions (L x W x H): 15 mm x 19 mm x 5.6 mm (5/8" x 3/4" x 1/4")

For U.S.A.

This device complies with Part 15 of the FCC Rules. Operation is subject to the following two conditions: (1) This device may not cause harmful interference, and (2) this device must accept any interference received, including interference that may cause undesired operation.

FCC Caution:

This equipment may generate or use radio frequency energy. Changes or modifications to this equipment may cause harmful interference unless the modifications are expressly approved in the instruction manual. The user could lose the authority to operate this equipment if an unauthorized change or modification is made.

For U.S.A. and CANADA

This equipment complies with FCC/IC radiation exposure limits set forth for an uncontrolled environment and meets the FCC radio frequency (RF) Exposure Guidelines in Supplement C to OET65 and RSS-102 of the IC radio frequency (RF) Exposure rules. This equipment has very low levels of RF energy that it deemed to comply without maximum permissive exposure evaluation (MPE). But it is desirable that it should be installed and operated keeping the radiator at least 20 cm or more away from person's body (excluding extremities: hands, wrists, feet and ankles).

For CANADA

This device complies with RSS-210 of industry Canada Rules. Operation is subject to the following two conditions: (1) this device may not cause interference, and (2) this device must accept any interference, including interference that may cause undesired operation of the device.

Under Industry Canada regulations, this radio transmitter may only operate using an antenna of a type and maximum (or lesser) gain approved for the transmitter by Industry Canada. To reduce potential radio interference to other users, the antenna type and its gain should be so chosen that the equivalent isotropically radiated power (e.i.r.p.) is not more than that necessary for successful communication.



Information for Users on Disposal of Old Equipment and Batteries

[European Union only]

These symbols indicate that the product and the battery with this symbol should not be disposed as general household waste at its end-of-life.

If you wish to dispose of this product and the battery, please do so in accordance with applicable national legislation or other rules in your country and municipality.

By disposing of this product correctly, you will help to conserve natural resources and will help prevent potential negative effects on the environment and human health.

Notice:

The sign Pb below the symbol for batteries indicates that this battery contains lead.

- The Bluetooth word mark and logos are owned by the Bluetooth SIG, Inc. and any use of such marks by JVC KENWOOD Corporation is under license. Other trademarks and trade names are those of their respective owners.
- This adapter has been designed exclusively for use with JVC's car receivers. Do not use this adapter with any other car receiver. For details, see also the Instructions supplied with your receiver.

FRANÇAIS

Pour les États-Unis et le CANADA

Cet équipement est conforme aux limites d'exposition aux rayonnements énoncées pour un environnement non contrôlé et respecte les règles d'exposition aux fréquences radioélectriques (RF) CNR-102 de l'IC. Cet équipement émet une énergie RF très faible qui est considérée conforme sans évaluation de l'exposition maximale autorisée. Cependant, cet équipement doit être installé et utilisé en gardant une distance de 20 cm ou plus entre le dispositif rayonnant et le corps (à l'exception des extrémités : mains, poignets, pieds et chevilles).

Pour le CANADA

Cet appareil est conforme au règlement CNR-210 de l'industrie du Canada. L'utilisation de ce dispositif est autorisée seulement aux conditions suivantes: (1) il ne doit pas produire de brouillage et (2) l'utilisateur du dispositif doit être prêt à accepter tout brouillage radioélectrique reçu, même si ce brouillage est susceptible de compromettre le fonctionnement du dispositif.

Conformément à la réglementation d'Industrie Canada, le présent émetteur radio peut fonctionner avec une antenne d'un type et d'un gain maximal (ou inférieur) approuvé pour l'émetteur par Industrie Canada. Dans le but de réduire les risques de brouillage radioélectrique à l'intention des autres utilisateurs, il faut choisir le type d'antenna et son gain de sorte que la puissance isotrope rayonnée équivalente (p.i.r.e.) ne dépasse pas l'intensité nécessaire à l'établissement d'une communication satisfaisante.



Informations relatives à l'élimination des appareils et des piles usagés, à l'intention des utilisateurs [Union européenne seulement]

Ces symboles signifient que le produit et les piles ne doivent pas être éliminés en tant que déchet ménager à la fin de son cycle de vie.

Si vous souhaitez éliminer ce produit et les piles, faites-le conformément à la législation nationale ou autres règles en vigueur dans votre pays et votre municipalité.

En éliminant correctement ce produit, vous contribuez à la conservation des ressources naturelles et à la prévention des éventuels effets négatifs sur l'environnement et la santé humaine.

Notification:

La marque Pb en dessous du symbole des piles indique que cette pile contient du plomb.

- La marque du mot et les logos Bluetooth sont la propriété de Bluetooth SIG, Inc. et toute utilisation de ces marques par JVC KENWOOD Corporation est faite sous licence. Les autres marques et noms de commerce sont la propriété de leur propriétaire respectif.
- Cet adaptateur a été conçu spécialement pour être utilisé avec un autoradio JVC. N'utilisez pas cet adaptateur avec un autre autoradio. Pour plus de détails, référez-vous aux instructions fournies avec votre autoradio.

ESPAÑOL



Información para los usuarios sobre la eliminación de equipos y baterías/pilas usados

[Solo Unión Europea]

Estos símbolos indican que el producto y la batería que llevan este símbolo no deben desecharse junto con la basura doméstica al final de su vida útil.

Si desea desechar este producto y la batería, hágalo de conformidad con la legislación nacional vigente u otras normativas de su país y municipio.

Si desecha el producto correctamente, estará contribuyendo a conservar los recursos naturales y a prevenir los posibles efectos negativos en el medio ambiente y en la salud de las personas.

Atención:

La indicación Pb debajo del símbolo de batería/pila indica que ésta contiene plomo.

- La marca Bluetooth y sus logotipos son propiedad de Bluetooth SIG, Inc., y cualquier uso de los mismos por JVC KENWOOD Corporation se realiza bajo licencia. Otras marcas y nombres comerciales son de sus respectivos propietarios.
- Este adaptador ha sido diseñado para usarse exclusivamente con los receptores para automóvil de JVC. No utilice este adaptador con ningún otro receptor para automóvil. Para obtener más detalles, consulte también las instrucciones suministradas con su receptor.

DEUTSCH



Benutzerinformationen zur Entsorgung alter Geräte und Batterien

[Nur Europäische Union]

Diese Symbole zeigen an, dass das damit gekennzeichnete Produkt bzw. die Batterie nicht als normale Haushaltsabfall entsorgt werden sollen.

Wenn Sie dieses Produkt und die Batterie entsorgen möchten, halten Sie sich dabei bitte an die entsprechenden Landesgesetze und andere Regelungen in Ihrem Land bzw. Ihrer Gemeinde.

Die korrekte Entsorgung dieses Produkts dient dem Umweltschutz und verhindert mögliche Schäden für die Umwelt und die menschliche Gesundheit.

Hinweis:

Das Zeichen Pb unterhalb des Batteriesymbols gibt an, dass diese Batterie Blei enthält.

- Die Wortmarke Bluetooth und die Logos sind Eigentum der Bluetooth SIG, Inc., und jegliche Verwendung solcher Marken durch die JVC KENWOOD Corporation geschieht unter Lizenz. Andere Warenzeichen und Handelsnamen sind Eigentum ihrer jeweiligen Besitzer und werden von uns anerkannt.
- Dieser Adapter wurde ausschließlich zur Verwendung mit Auto-Receiver von JVC entworfen. Verwenden Sie diesen Adapter nicht mit einem anderen Auto-Receiver. Einzelheiten siehe mit Ihrem Receiver mitgelieferte Bedienungsanleitung.

Informace pro uživatele k likvidaci starého zařízení a baterií
[Pouze pro Evropskou unii]
 Tyto symboly znamenají, že produkt a baterie s tímto symbolem nesmí být po skončení životnosti likvidovány jako běžný odpad.
 Přejete-li si zlikvidovat tento produkt a baterie, proveďte to prosím v souladu s příslušnými národními zákony nebo jinými předpisy platnými ve vaší zemi a obci.
 Správnou likvidaci tohoto produktu pomůžete zachovat přírodní zdroje a napomáháte prevenci potenciálních negativních dopadů na životní prostředí a lidské zdraví.
Upozornění:
 Značka Pb pod symbolem pro baterie znamená, že tato baterie obsahuje olovo.

- Značka a logo Bluetooth a vlastní společnost Bluetooth SIG, Inc. Jakékoli používání těchto značek společností JVC KENWOOD Corporation podléhá podmínkám licence. Ostatní ochranné známky a obchodní názvy náležejí příslušným vlastníkům.
- Tento adaptér byl navržen výlučně pro použití s přijímačem JVC do vozidla. Nepoužívejte tento adaptér s jiným přijímačem do vozidla. Podrobnosti najdete rovněž v příručce dodané s Vaším přijímačem.

[สำหรับใช้ในสหภาพยุโรปเท่านั้น]

- โลโก้และเครื่องหมายคำว่า Bluetooth เป็นของ บริษัท Bluetooth SIG, Inc. และการใช้เครื่องหมายดังกล่าวโดยบริษัท JVC KENWOOD Corporation อยู่ภายใต้การอนุญาตใช้เครื่องหมายการค้าและชื่อทางการค้าอื่น ๆ เป็นสิทธิของเจ้าของเครื่องหมายการค้าดังกล่าว
- อะแดปเตอร์นี้ได้รับการออกแบบให้ใช้กับอุปกรณ์รับสัญญาณในรถยนต์ของ JVC เท่านั้น อย่าใช้อะแดปเตอร์นี้กับอุปกรณ์รับสัญญาณในรถยนต์ชนิดอื่น ๆ สำหรับรายละเอียดอื่น ๆ โปรดดูจากคู่มือที่จัดส่งให้พร้อมกับเครื่องรับสัญญาณของคุณ

Felhasználói információ az elhasznált berendezések és akkumulátorok elhelyezéséről
[Csak Európai Unió]
 Ezek a szimbólumok azt jelzik, hogy az ilyen jelzéssel ellátott terméket és akkumulátort hasznos élettartama végén nem szabad háztartási szemétként kezelni.
 A jelen termék és akkumulátor hulladékként kezelésekor járjunk el az idevágó országos rendelkezések vagy az adott országban, illetve helyhatósági körzetben érvényes egyéb előírások szerint.
 A termék megfelelő ártalmatlanításával segít megőrizni a természetes erőforrásokat, és megelőzheti a környezetre és az egészségre gyakorolt ártalmas hatásokat.
Megjegyzés:
 Az alábbi Pb szimbólum - ha az akkumulátoron megtalálható - azt jelzi, hogy az akkumulátor ólmot tartalmaz.

- A Bluetooth szó a Bluetooth SIG, Inc. saját tulajdonú jelzése és logója, és a JVC KENWOOD Corporation licenc alapján használja e jelzéseket. A többi kereskedelmi védjegy és megnevezés az érintett tulajdonosok birtokában van.
- Ez az adapter kizárólag a JVC autórádiókhoz használható. Ne próbálkozzunk más autórádiókat megtáplálni vele. A részleteket lásd a vevőhöz mellékelte útmutatókban.

[유럽연합에만 해당]

- Bluetooth 단어 표시 및 로고는 Bluetooth SIG, Inc. 의 소유이며 JVC KENWOOD Corporation 에서 라이선스를 받아서 이 표시를 사용합니다. 다른 상표와 상호는 해당 소유주의 상표와 상호입니다.
- 이 어댑터는 JVC 자동차 수신기 용으로 특별히 제작된 것입니다. 이 어댑터를 다른 자동차 수신기에 사용하지 마십시오. 더 자세한 정보는 수신기에 제공된 설명서를 참조하십시오.

[僅對應歐洲聯盟]

- Bluetooth 字符和標識屬 Bluetooth SIG, Inc. 所有, 並為 JVC KENWOOD Corporation 在許可下使用. 其他商標和商品名稱分別屬其他所有者所有.
- 該適配器專為 JVC 汽車接收機的使用而設計. 切勿與其他汽車接收機一起使用該適配器. 詳情參閱隨接收機附帶的使用說明書.

[Тільки для Європейського Союзу]

- Текстова торгівельна марка та логотипи Bluetooth є власністю Bluetooth SIG, Inc. Використання цих марок компанією JVC KENWOOD Corporation здійснюється за ліцензією. Інші торгівельні марки та торгові назви належать відповідним власникам.
- Даний адаптер розроблений виключно для використання з автомобільними приймачами компанії JVC. Заборонено використовувати даний адаптер з будь-якими іншими автомобільними приймачами.
 Для більш детального ознайомлення дивіться інструкцію, що входить до комплекту постачання приймача.

[الاتحاد الأوروبي فقط]

- علامة كلمة Bluetooth و شعاراتها مملوكة لشركة Bluetooth SIG, Inc. وأي استخدام لمثل هذه العلامات بواسطة شركة JVC KENWOOD Corporation يتم بموجب ترخيص. العلامات التجارية الأخرى والأسماء التجارية ملك لأصحابها.
- تم تصميم هذا المحول للاستخدام حصري مع مستقبل السيارة من JVC لا تستخدم هذا المحول مع أي مستقبل سيارة آخر.
- للحصول على التفاصيل. انظر أيضاً التعليمات المصاحبة للمستقبل الخاص بك.

Informații pentru utilizatori cu privire la evacuarea ca deșeu a echipamentelor și bateriilor vechi
[Doar în Uniunea Europeană]
 Aceste simboluri indică faptul că produsul și bateriile cu acest simbol nu trebuie să fie evacuate la fel ca deșeurile menajere la finalul duratei de viață.
 Dacă doriți să evacuați ca deșeu acest produs și baterie, vă rugăm să faceți acest lucru în conformitate cu legislația în vigoare sau cu alea prevederi din țara sau municipalitatea dumneavoastră.
 Prin evacuarea corectă a acestui produs, veți ajuta la conservarea resurselor naturale și veți contribui la prevenirea posibilelor efecte negative asupra mediului și sănătății umane.
Observație:
 Semnul Pb de mai jos pentru baterii indică faptul că bateria conține plumb.

- Cuvântul și siglele Bluetooth sunt deținute de Bluetooth SIG, Inc. și sunt utilizate de JVC KENWOOD Corporation sub licență. Celelalte mărci comerciale și nume comerciale aparțin posesorilor acestora.
- Acest adaptor a fost realizat pentru utilizarea exclusivă cu aparatele auto JVC. Nu folosiți acest adaptor cu alte aparate auto. Pentru mai multe detalii, consultați instrucțiunile furnizate cu aparatul dumneavoastră.

[فقط اتحاديه اروپا]

- كلمة Bluetooth و نشانهای آن متعلق به شرکت Bluetooth SIG, Inc. می باشد و هر گونه استفاده از این علائم در انحصار و تحت مجوز شرکت JVC KENWOOD Corporation می باشد. سایر نشان های تجاری و نام های تجاری مربوط به مالکین مربوطه می باشد.
- این آداپتور منحصرأ برای استفاده با گیرنده های JVC مخصوص اتومبیل طراحی شده است. از این آداپتور به همراه سایر درگیر کنید.
- برای اطلاعات بیشتر، به دفتر چه راهنمای ارائه شده همراه با گاید.

Информация за потребителите на депонирани старо оборудване и батерии
[Само за Европейския съюз]
 Тези символи указват, че продуктът и батерията с този символ не трябва да се депонират като битови отпадъци в края на експлоатационния им срок.
 Ако желаете да депонирате този продукт и батерията, моля, направете го в съответствие с приложимото национално законодателство или други правила във вашата страна и община.
 Чрез правилното депониране на този продукт ще помогнете за запазването на природните ресурси и предотвратяването на потенциалните отрицателни последици за околната среда и човешкото здраве.
Предупреждение:
 Знакът Pb под символа за батерии указва, че тази батерия съдържа олово.

- Марката и логото на Bluetooth са собственост на Bluetooth SIG, Inc., и всяко използване на тези марки от страна на JVC KENWOOD Corporation става по лиценз. Останалите търговски марки и търговски названия са в съответствие с притежателите.
- Този адаптер е предназначен за изключителна употреба с автомобилни приемници на JVC. Да не се използва адаптерът с друг автомобилни приемник.

[Hanya Uni Eropa]

- Tanda kata dan logo Bluetooth dimiliki oleh Bluetooth SIG, Inc. dan segala penggunaan tanda tersebut oleh JVC KENWOOD Corporation adalah berdasarkan lisensi. Merek dagang dan nama dagang lainnya adalah hak pemilik masing-masing.
- Adaptor ini memiliki desain eksklusif untuk digunakan dengan car receiver (alat penerima di mobil) JVC. Jangan gunakan adaptor ini dengan unit penerima mobil yang lain. Untuk rincian selengkapnya, baca petunjuk yang dibekalkan dengan alat penerima.

Декларация про Відповідність Вимогам Технічного Регламенту Обмеження Використання деяких Небезпечних Речовин в електричному та електронному обладнанні (затвердженого Постановою №1057 Кабінету Міністрів України)
 Виріб відповідає вимогам Технічного Регламенту Обмеження Використання деяких Небезпечних Речовин в електричному та електронному обладнанні (ТР ОБВНР).
 Вміст небезпечних речовин у випадках, не обумовлених в Додатку №2 ТР ОБВНР:
 1. свинець (Pb) – не перевищує 0.1 % ваги речовини або в концентрації до 1000 частин на мільйон;
 2. кадмій (Cd) – не перевищує 0.01 % ваги речовини або в концентрації до 100 частин на мільйон;
 3. ртуть (Hg) – не перевищує 0.1 % ваги речовини або в концентрації до 1000 частин на мільйон;
 4. шестивалентний хром (Cr⁶⁺) – не перевищує 0.1 % ваги речовини або в концентрації до 1000 частин на мільйон;
 5. полібромбіфеноли (PBB) – не перевищує 0.1 % ваги речовини або в концентрації до 1000 частин на мільйон;
 6. полібромдефінілові ефіри (PBDE) – не перевищує 0.1 % ваги речовини або в концентрації до 1000 частин на мільйон.

Türkiye İçin
 Bu ürün 26891 sayılı Resmî Gazete'de yayımlanan Elektrikli ve Elektronik Eşyalarda Bazı Zararlı Maddelerin Kullanımının Sınırlandırılmasına Dair Yönetmeliğe uygun olarak üretilmiştir.



■ The countries where you may use the Bluetooth® function

- Die Länder, in denen Sie die Bluetooth® Funktion verwenden können
- Pays où vous pouvez utiliser la fonction Bluetooth®
- De landen waar u de Bluetooth®-functie mag gebruiken
- Países en los que se puede utilizar la función Bluetooth®
- Paesi nei quali è possibile utilizzare la funzione Bluetooth®
- Länder där du kan använda Bluetooth®-funktionen
- Lande, hvor du kan bruge Bluetooth®-funktionen
- Land hvor du kan bruke Bluetooth®-funksjonen
- Maat, joissa voi käyttää Bluetooth®-toimintoa
- Países onde pode usar a função Bluetooth®
- Países onde você pode usar a função Bluetooth®
- Οι χώρες όπου μπορείτε να χρησιμοποιήσετε τη λειτουργία Bluetooth®
- Страны, где можно воспользоваться функцией Bluetooth®
- Země, ve kterých můžete využívat funkci Bluetooth®
- Azok az országok, amelyekben használhatjuk a Bluetooth®-funkciót
- Kraje, w których można używać funkcji Bluetooth®
- Države, kjer lahko uporabljate funkcijo Bluetooth®
- Krajiny, v ktorých môžete využívať funkciu Bluetooth®
- Valstis, kur jūs varat izmantot Bluetooth® funkciju
- Šalys, kuriose galite naudotis „Bluetooth®“ funkcija
- Il-pajjiżi fejn tista' tuża l-funzjoni Bluetooth®
- Lönd þar sem hægt er að nota Bluetooth®
- Riigid, kus on võimalik kasutada Bluetooth® funktsiooni
- Bluetooth® fonksiyonunu kullanabileceğiniz ülkeler
- ประเทศที่ท่านสามารถใช้ Bluetooth® ฟังก์ชัน
- Na tíortha inar féidir leat feidhmiú Bluetooth® a úsáid
- Länner an denen der d'Bluetooth® Funktioun benotze kënnt.
- Ở những quốc gia mà bạn có thể sử dụng chức năng Bluetooth®
- Els països on podrà fer servir la funció Bluetooth®
- Zemlje u kojima je dozvoljena upotreba Bluetooth® funkcije.
- Zemlje u kojima možete koristiti Bluetooth® funkciju
- Zemlje u kojima je dopušteno koristiti Bluetooth®.
- Земји каде можете да ја користите функцијата Bluetooth®
- Страните, в които можете да ползвате функцията Bluetooth®
- Țările în care puteți utiliza funcția Bluetooth®
- Die lande waar u die Bluetooth®-funksie kan gebruik
- Amazwe lapho ungasebenzisa khona uhlelo lwe-Bluetooth®
- Ang mga bansa kung saan maaari kang gumamit ng Bluetooth® function
- Negara-negara yang membolehkan penggunaan fungsi Bluetooth®
- Negara-negara yang anda boleh menggunakan fungsi Bluetooth®
- वे देश जहाँ आप Bluetooth® कार्य-क्षमता का उपयोग कर सकते हैं
- 您能够使用 Bluetooth® 功能的国家
- 您能夠使用 Bluetooth® 功能的國家
- Bluetooth® 기능을 사용할 수 있는 국가

■ الدول التي يمكنك استخدامها وظيفه Bluetooth® فيها

Country
Andorra
الإمارات العربية المتحدة
Australia
Österreich
Bosna i Hercegovina
Belgien Belgique
България
Brasil
Canada
Schweiz Suisse
Chile
Κύπρος Kıbrıs
Česká republika
Deutschland
Danmark
Eesti
España
Suomi Finland
France
United Kingdom
Ελλάδα
Hong Kong 香港 香港
Hrvatska
Magyarország
Indonesia

Country
Ireland Éire
India भारत
Ísland
Italia
대한민국
Lichtenstein
Lietuva
Luxemburg Luxembourg Lëtzebuerg
Latvija
Monaco
Crna Gora
Македонија
Malta
Malaysia
Nederland
Norge
New Zealand
Perú
Philippines Pilipinas
Polska
Portugal
República Oriental del Uruguay
România
Srbija
Россия

Country
Sverige
Singapore 新加坡 Singapura
Slovenija
Slovensko
ประเทศไทย
Türkiye
台灣
United States of America
Venezuela
Vietnam Việt Nam
South Africa ENingizimu Afrika Suid-Afrika

**REMOVE THIS LABEL FROM CABLE BEFORE USE.
RETIRE LA ETIQUETA DEL CABLE ELÉCTRICO ANTES DE USAR.
RETIREZ CETTE ÉTIQUETTE DU CÂBLE AVANT UTILISATION.**



CAUTION CONNECT BLACK WIRE (① GND) TO GROUND FIRST. OTHERWISE, DAMAGE TO YOUR UNIT MAY OCCUR.

**INCORRECT CONNECTION CAUSES SERIOUS DAMAGE TO THIS UNIT
PLEASE READ INSTALLATION/CONNECTION MANUAL CAREFULLY.**

①

CONNECT GROUND FIRST

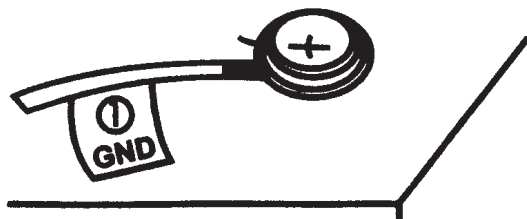

**METALLIC BODY OR CHASSIS
OF THE CAR**

②

CONNECT OTHER WIRES

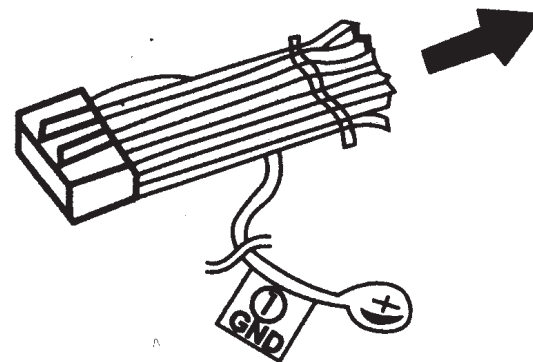

③

CONNECT ANTENNA TERMINAL

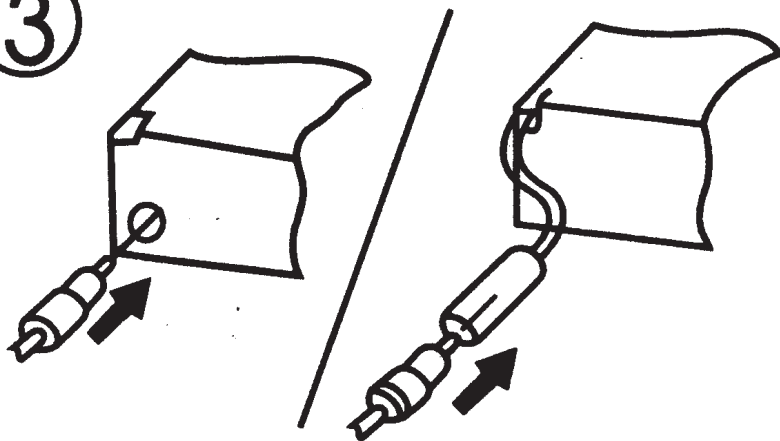

④

**CONNECT POWER CORD TO
THE UNIT**

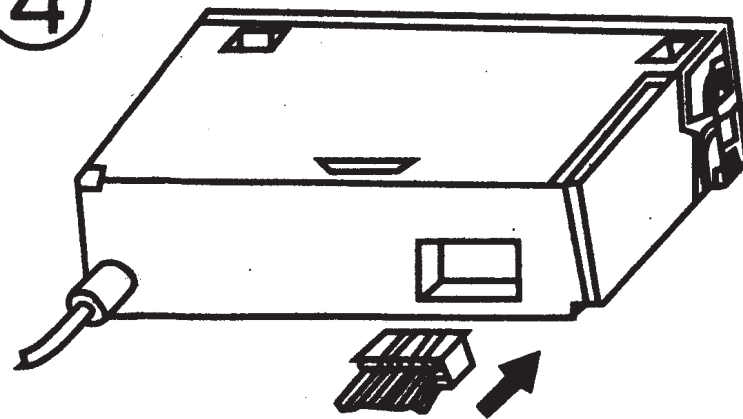

Please do not send products or other correspondence to this address.

JVC AMERICAS CORP.
1700 Valley Road
Wayne, NJ 07470



PLEASE
PLACE
STAMP
HERE



PO BOX 1189
BEDFORD, TX 76095-1189



PRODUCT REGISTRATION CARD / QUESTIONNAIRE

USA CUSTOMERS ONLY

Registering your product will allow us to contact you in the unlikely event a product safety notification is required.

This form is for Product Registration purposes only. Failure to return this form does not diminish your rights during the warranty period.

THANK YOU FOR PURCHASING THIS JVC PRODUCT

REGISTER ONLINE AT: *REGISTER.JVC.COM*



PRODUCT REGISTRATION

First Name: _____

Last Name: _____

Address: _____

Apt.# _____

City: _____

State: _____

Zip Code: _____

Phone Number: _____

E-Mail Address: _____

- | | | |
|---|-----|----|
| 1) Would you like to receive the JVC Community e-mail newsletter? | Yes | No |
| 2) Would you like to receive special offers from JVC? | Yes | No |
| 3) Have you purchased an extended warranty for this product? | Yes | No |

Date of Purchase _____

Model Number: _____

Serial Number: _____

Purchase Price: _____

Dealer: _____

On a scale of 1 to 5, with 5 being the best, please rate each of the following attributes about your new JVC product.

Performance	1	2	3	4	5
Features	1	2	3	4	5
Ease of use	1	2	3	4	5
Design	1	2	3	4	5
Value	1	2	3	4	5

COMMENTS:

Thank You
for completing
this questionnaire.

CANADA
ONLY

JVC

CANADA
SEULEMENT

OWNER'S COPY OF WARRANTY CARD COPIE D'ENREGISTREMENT DE LA GARANTIE DU PROPRIÉTAIRE

(Save sales docket together with this warranty card, as a proof of date of purchase.
La facture et cette garantie sont vos preuves de la date d'achat; rangez-les.)

MODEL / MODÈLE : SERIAL NO. / NO DE SÉRIE :

Purchase from / Acheté chez : Date purchased / Date acheté :

Dealer's Address / Adresse du Vendeur :

No. / No Street / Rue

City or Town / Ville Prov. / Prov. Postal Code / Code Postal

Owner's Name / Nom du Propriétaire :

Owner's Address / Adresse du Propriétaire :

No. / No Street / Rue Apt. / App.

City or Town / Ville Prov. / Prov. Postal Code / Code Postal

BT-52008-1
(1007)

Detach here.

à découper ici

Printed in Indonesia

WARRANTY CONTROL CARD CARTE DE CONTRÔLE DE LA GARANTIE

IMPORTANT: This warranty control card must be filled in and posted to the address indicated on the back hereof or register via internet within 7 (seven) days from the date of purchase.

IMPORTANT: Cette carte doit être renvoyée dûment remplie à l'adresse indiquée au verso, dans les 7 jours de la date d'achat ou aller sur le site par internet pour l'enregistrement.

(PLEASE PRINT/EN LETTRES MOULÉES)

MODEL / MODÈLE : SERIAL NO. / NO DE SÉRIE :

Purchased from / Acheté chez : Date purchased / Date acheté :

Dealer's Address / Adresse du Vendeur :

No. / No Street / Rue

City or Town / Ville Prov. / Prov. Postal Code / Code Postal

Owner's Name / Nom du Propriétaire :

Owner's Address / Adresse du Propriétaire :

No. / No Street / Rue Apt. / App.

City or Town / Ville Prov. / Prov. Postal Code / Code Postal

You may also register on-line
at: www.jvc.ca

Vous pouvez également vous
inscrire par internet à: www.jvc.ca

WARRANTY APPLIES ONLY TO PRODUCT
DISTRIBUTED IN CANADA BY JVC CANADA INC.

LA GARANTIE S'APPLIQUE SEULEMENT AUX PRODUITS
DISTRIBUES AU CANADA PAR JVC CANADA INC.

Warranty applies only
to PRODUCT distributed
in Canada by JVC Canada
Inc.

JVC

La garantie s'applique
seulement aux PRODUITS
distribués au Canada par
JVC Canada Inc.

WARRANTY GARANTIE

JVC CANADA INC.

21 Finchdene Square, Toronto, ON M1X 1A7

TEL: (416) 293-1311 FAX: (416) 293-8208

<http://www.jvc.ca>

JVC CANADA INC. (hereafter called "JVC") gives the following express warranty for each new JVC product distributed in Canada by JVC and sold by an authorized JVC dealer.

JVC warrants that this JVC product is free, under normal use and maintenance, from any defects in material and workmanship subject to the following terms and conditions:

1. To Obtain Warranty Service:

- The JVC Warranty Control Card herein provided must be completed in full and posted or registered via internet within 7 days of date of purchase of the JVC product.
- This JVC Warranty Control Card must be completed in full and presented together with proof of purchase of the JVC product requiring service.
- The JVC product must be brought in for service to an authorized JVC Service Centre.

2. Limitation:

This Warranty shall not apply to:

- Repair or replacement of any cabinets, batteries, plates, connection cords, antennas, dust covers, knobs, speaker grills, speaker cones, projection screens, projection screen savers, and all accessories.
- Any defects caused or repairs required as a result of misuse, abusive operation, negligence, improper use and/or insufficient care.
- Any defect caused or repairs required as a result of not following the instructions in the operation manual.
- Any JVC product tampered with, adjusted or repaired by any party other than JVC or authorized JVC Service Centre personnel.

JVC CANADA INC. (ci-après appelé "JVC") énonce la garantie expresse suivante pour tout nouveau produit JVC distribué au Canada par JVC et vendu par un détaillant JVC autorisé.

JVC vous garantit que ce produit est dégagé, sous utilisation et entretien normal, de tout défaut matériel et de fabrication sous réserve des modalités et conditions suivantes :

1. Pour obtenir un service de garantie :

- La carte de contrôle de garantie JVC ci-incluse doit être complétée avec les renseignements complets et être postée ou enregistrée via internet dans les 7 jours suivant l'achat du produit JVC.
- Cette carte de contrôle de garantie JVC doit être dûment remplie et être présentée avec la preuve d'achat du produit JVC nécessitant une réparation.
- Le produit JVC doit être apporté pour service chez un centre de service JVC autorisé.

2. Restrictions:

Cette garantie ne s'applique pas aux :

- Réparation ou remplacement de tout cabinet, batteries, panneau avant, cordons de raccord, antennes, housses de protection, boutons, couverts de haut-parleur, cônes de haut-parleur, écrans de projection, protecteurs d'écran de projection et tous les accessoires.
- Tous défauts occasionnés ou réparations requises suite à une utilisation abusive, mauvaise, négligente et/ou une utilisation incorrecte.
- Tous défauts occasionnés ou réparations requises suite à l'omission de suivre les recommandations du manuel d'instruction.
- Tout produit JVC altéré, ajusté ou réparé par tout autre entreprise que JVC ou un centre de service d'entretien ou de service autorisé JVC.

- (e) Any JVC products on which the serial number has been defaced, modified or removed.
- (f) Maintenance, cleaning or periodic check-up
- (g) Conversion to foreign or domestic voltage or frequency.
- (h) Any JVC product without the Canadian Electrical Safety Regulations ID.
- (i) Any JVC products used for commercial or institutional, rental, or display purposes.
Parts.....1 year (except video head - 90 days)
Labour.... 90 days
- (j) Any JVC product which has been resold and no longer owned by the original purchaser.
- (k) Product purchased from "outside Canada", "bankruptcy" or "liquidator".

- (e) Tout produit JVC dont le numéro de série a été altéré, modifié ou enlevé.
- (f) L'entretien, les vérifications périodiques et nettoyage.
- (g) La conversion à une fréquence ou une tension étrangère ou domestique.
- (h) Tout produit JVC n'ayant pas le sigle d'identification conforme aux normes électriques Canadiennes (CSA).
- (i) Pour tout produit utilisé à des fins commerciales, institutionnelles, de location ou utilisé à des fins d'étalage.
Pièces..... 1 An (Excepté les têtes vidéo- 90 jours)
Main d'œuvre... 90 Jours
- (j) Tout produit JVC ayant été revendu et qui n'est plus la propriété de l'acheteur original.
- (k) Produit acheté à "l'extérieur du Canada", provenant d'une "faillite" ou d'un "liquidateur".

- (l) Any defects caused by fire, flood, lightning, power surge, or other events beyond the control of JVC.
- (m) FOR AUTO PRODUCTS
Warranty does not cover elimination of car static or electrical interferences, cleaning of head, adjustments, or labour cost for the removal or reinstallation of the unit for repair.

- (l) Tout dommage causé par le feu, une inondation, un éclair, une surtension ou tout autre événement hors du contrôle de JVC.
- (m) POUR LES PRODUITS D'AUTOMOBILE
La garantie ne couvre pas l'élimination d'interférences statiques ou électriques de la voiture, le nettoyage de tête, les ajustements et les coûts de main d'œuvre associés à l'enlèvement ou à la réinstallation de l'unité pour réparation.

**WARRANTY TERM (VALID FROM THE DATE OF PURCHASE)
CONDITIONS DE GARANTIE (VALABLE à PARTIR DE LA DATE D'ACHAT)**

PRODUCT PRODUIT	PARTS (Years) PIECES (années)	Labour (Years) MAIN-D'OEUVRE (années)
Projection TV In-Home Service Colour TV In-Home (25" and above) D-ILA Rear Projection In-Home Service LCD TV In-Home Service (25" and above) Écrans de projection Service à Domicile Écrans de TV Couleur Service à Domicile (25" et plus) TV projection arrière D-ILA Service à Domicile Écrans de LCD Service à Domicile (25" et plus)	1	1
* In-home service to be provided where available Where it is not available, the Purchaser must assume the responsibility and expense for the proper packing, shipment and all costs associated with the delivery of the equipment to and from the closest JVC Authorized Service Centre. * Service à domicile fourni par un détaillant disponible. S'il n'y a pas de service JVC disponible à proximité, l'acheteur doit assumer la responsabilité et les coûts pour un emballage adéquat, l'expédition, ainsi que tous les coûts associés, à la livraison de l'équipement chez et depuis le détaillant JVC autorisé le plus près pour un service d'entretien.		
Receivers and Home Speakers purchased separately, Front Projection and Car Audio "ARSENAL" Series Récepteurs et Hauts-Parleurs achetés séparément, Projecteur Avant et Audio d'Auto de Série « ARSENAL »	2	2
AC Adapters, Remote Controls, Headphones, Microphones and Projector Lamps Adaptateurs AC, Télécommande, Casque D'écoute, Microphones et Lampe de Projecteur	90 DAYS 90 JOURS	90 DAYS 90 JOURS
Wood Cone Speakers Enceinte à Cône en Bois	5	5
All Other Categories Toutes les autres catégories	1	1

3. Standards:

If any defects should be found in a JVC product within the applicable terms, necessary repairs shall be made at no cost to the purchaser for parts or labour when JVC acknowledges that such defects are due to faulty material or workmanship.

4. Exclusion of All Other Express Warranties:

This warranty constitutes the entire express warranty given by JVC for JVC products and no dealer or service centre personnel or his, its or their agent or employee is, or are authorized to extend or enlarge this warranty on behalf of JVC.

5. Disclaimer of Consequential Damage:

To the extent the law permits JVC disclaims any responsibility for loss of time or use of its product, transportation costs, or any other indirect, incidental or consequential damage or inconvenience.

3. Critères:

Si un produit JVC s'avérait défectueux, selon les conditions applicables, les réparations nécessaires seront effectués sans coûts additionnels à l'acheteur pour les pièces et la main d'œuvre lorsque JVC reconnaît que de telles déficiences sont causées par une défectuosité de matériel ou de fabrication.

4. Exclusion de toutes autres garanties expresses :

Cette garantie constitue l'entière garantie express donnée par JVC pour les produits JVC. Nul représentant ou employé d'un détaillant ou d'un service d'entretien n'est autorisé à prolonger cette garantie au nom de JVC.

5. Dénégation des dommages indirects :

Dans la mesure permise par la loi, JVC nie toute responsabilité pour perte de temps ou d'usage de ses produits, des coûts de transport ou tout autre dommage ou inconvénient indirect, accidentel et conséquent.

New

And mail to the address below.
You may also register on-line at: www.jvc.ca

Nouveau

Veuillez poster à l'adresse ci-dessous.
Vous pouvez également vous enregistrer par internet à; www.jvc.ca

Detach here.

à découper ici

Place stamp here
Placez votre timbre ici

JVC CANADA INC.

21 Finchdene Square
Toronto, ON M1X 1A7

TO OUR VALUED CUSTOMER ———

THANK YOU FOR PURCHASING THIS JVC PRODUCT.
WE WANT TO HELP YOU ACHIEVE A PERFECT EXPERIENCE.

**NEED HELP ON HOW TO HOOK UP?
NEED ASSISTANCE ON HOW TO OPERATE?
NEED TO LOCATE A JVC SERVICE CENTER?
LIKE TO PURCHASE ACCESSORIES?**

JVC[®] IS HERE TO HELP!
TOLL FREE: 1(800)252-5722
<http://www.jvc.com>

Remember to retain your Bill of Sale for Warranty Service.

————— **Do not attempt to service the product yourself** —————

Caution

To prevent electrical shock, do not open the cabinet.
There are no user serviceable parts inside.
Please refer to qualified service personnel for repairs.



LIMITED WARRANTY

1-1 **USA ONLY**

ONLY FOR PRODUCT PURCHASED IN U.S.A.

JVC Americas Corp. (JVC) warrants this product and all parts thereof, except as set forth below **ONLY TO THE ORIGINAL RETAIL PURCHASER** to be **FREE FROM DEFECTIVE MATERIALS AND WORKMANSHIP** from the date of original purchase for the period shown below. ("The Warranty Period")

PARTS	1 YR	LABOR	1 YR
-------	-------------	-------	-------------

THIS LIMITED WARRANTY IS VALID ONLY IN THE FIFTY (50) UNITED STATES, THE DISTRICT OF COLUMBIA AND IN THE COMMONWEALTH OF PUERTO RICO.

WHAT WE WILL DO:

If this product is found to be defective within the warranty period, JVC will repair or replace defective parts with new or rebuilt equivalents at no charge to the original owner. Such repair and replacement services shall be rendered by JVC during normal business hours at JVC authorized service centers. Parts used for replacement are warranted only for the remainder of the Warranty Period. All products may be brought to a JVC authorized service center on a carry-in basis. Color televisions with a screen size of 37" class or greater qualify for in-home service. In such cases, a technician will come to your home and either repair the TV there or remove and return it if it cannot be repaired in your home.

WHAT YOU MUST DO FOR WARRANTY SERVICE:

Please do not return your product to the retailer
Instead, return your product to the JVC authorized service center nearest you. If shipping the product to the service center, please be sure to package it carefully, preferably in the original packaging, and include a brief description of the problem(s). Please call 1-800-252-5722 to locate the nearest JVC authorized service center. Service locations can also be obtained from our website <http://www.jvc.com>. If your product qualifies for in-home service, the service representative will require clear access to the product.

If you have any questions concerning your JVC Product, please contact our Customer Care Center at 800-252-5722

WHAT IS NOT COVERED:

This limited warranty provided by JVC does not cover:

1. Products which have been subject to abuse, accident, alteration, modification, tampering, negligence, misuse, faulty installation, lack of reasonable care, or if repaired or serviced by anyone other than a service facility authorized by JVC to render such service, or if affixed to any attachment not provided with the products, or if the model or serial number has been altered, tampered with, defaced or removed;
2. Initial installation, installation and removal from cabinets or mounting systems.
3. Operational adjustments covered in the Owner's Manual, normal maintenance, video and audio head cleaning;
4. Damage that occurs in shipment, due to act of God, and cosmetic damage;
5. Signal reception problems and failures due to line power surge;
6. User Removal Memory Devices/Video Pick-up Tubes/CCD Image Sensors are covered for 90 days from the date of purchase;
7. Accessories;
8. Batteries (except that Rechargeable Batteries are covered for 90 days from the date of purchase);
9. Products used for commercial purposes, including, but not limited to rental.
10. Loss of data resultant from malfunction of hard drive or other data storage device;

There are no express warranties except as listed above.

THE DURATION OF ANY IMPLIED WARRANTIES, INCLUDING THE IMPLIED WARRANTY OF MERCHANTABILITY, IS LIMITED TO THE DURATION OF THE EXPRESS WARRANTY HEREIN.

JVC SHALL NOT BE LIABLE FOR ANY LOSS OF USE OF THE PRODUCT, INCONVENIENCE, OR ANY OTHER DAMAGES, WHETHER DIRECT, INCIDENTAL OR CONSEQUENTIAL (INCLUDING, WITHOUT LIMITATION, DAMAGE TO TAPES, RECORDS OR DISCS) RESULTING FROM THE USE OF THIS PRODUCT, OR ARISING OUT OF ANY BREACH OF THIS WARRANTY. ALL EXPRESS AND IMPLIED WARRANTIES, INCLUDING THE WARRANTIES OF MERCHANTABILITY AND FITNESS FOR PARTICULAR PURPOSE, ARE LIMITED TO THE WARRANTY PERIOD SET FORTH ABOVE.

Some states do not allow the exclusion of incidental or consequential damages or limitations on how long an implied warranty lasts, so these limitations or exclusions may not apply to you. This warranty gives you specific legal rights and you may also have other rights which vary from state to state.

JVC AMERICAS CORP.

1700 Valley Road, Wayne, New Jersey 07470
<http://www.jvc.com>

REFURBISHED PRODUCTS CARRY A SEPARATE WARRANTY, THIS WARRANTY DOES NOT APPLY. FOR DETAIL OF REFURBISHED PRODUCT WARRANTY, PLEASE REFER TO THE REFURBISHED PRODUCT WARRANTY INFORMATION PACKAGED WITH EACH REFURBISHED PRODUCT.

For customer use:

Enter below the Model No. and Serial No. which is located either on the rear, bottom or side of the cabinet. Retain this information for future reference.

Model No. :	Serial No. :
Purchase date :	Name of dealer :

Free Manuals Download Website

<http://myh66.com>

<http://usermanuals.us>

<http://www.somanuals.com>

<http://www.4manuals.cc>

<http://www.manual-lib.com>

<http://www.404manual.com>

<http://www.luxmanual.com>

<http://aubethermostatmanual.com>

Golf course search by state

<http://golfingnear.com>

Email search by domain

<http://emailbydomain.com>

Auto manuals search

<http://auto.somanuals.com>

TV manuals search

<http://tv.somanuals.com>