

**JOHN DEERE**  
WORLDWIDE COMMERCIAL & CONSUMER  
EQUIPMENT DIVISION

---

Lawn Sweeper  
42 Inch

OMM155002 C6

**OPERATOR'S MANUAL**



**JOHN DEERE**

All information, illustrations and specifications in this manual are based on the latest information at the time of publication. The right is reserved to make changes at any time without notice.

COPYRIGHT© 2006  
Deere & Co.

John Deere Worldwide Commercial and  
Consumer Equipment Division  
All rights reserved  
Previous Editions  
COPYRIGHT© 2004, 2005

North American Version  
Litho in U.S.A.

---

---

# INTRODUCTION

---

---

## Introduction

### Using Your Operator's Manual

Read this entire operator's manual, especially the safety information, before operating.

This manual is an important part of your machine. Keep all manuals in a convenient location so they can be accessed easily.

Use the safety and operating information in the attachment operator's manual, along with the machine operator's manual, to operate and service the attachment safely and correctly.

If your attachment manual has a section called Preparing the Machine, it means that you will have to do something to your tractor or vehicle before you can install the attachment. The Assembly and Installation sections of this manual provide information to assemble and install the attachment to your tractor or vehicle. Use the Service section to make any needed adjustments and routine service to your attachment.

If you have any questions or concerns with the assembly, installation, or operation of this attachment, see your local John Deere dealer or call John Deere Special Services at 1-866-218-8622 for assistance.

Warranty information on this John Deere attachment can be found in the warranty that came with your John Deere tractor or vehicle.

---

---

## Safety

Read the general safety operating precautions in your machine operator's manual for additional safety information.

### Operate Safely

- This attachment is intended for use in lawn care and home applications. Do not tow behind a vehicle on a highway or in any high speed application. Do not tow at speeds higher than maximum recommended towing speed.
- Towing speed should always be slow enough to maintain control. Travel slowly over rough ground.
- Do not let children or an untrained person operate machine.
- Do not let anyone, especially children, ride on machine or attachment. Riders are subject to injury such as being struck by foreign objects and being thrown off. Riders may also obstruct the operator's view, resulting in the machine being operated in an unsafe manner.
- Check machine brake action before you operate. Adjust or service brakes as necessary.
- Keep all parts in good condition and properly installed. Fix damage immediately. Replace worn or broken parts. Replace all worn or damaged safety and instruction decals.
- Do not modify machine or safety devices. Unauthorized modifications to the machine or attachment may impair its function and safety.
- Securely anchor all loads to prevent loads from falling.

### Towing Loads Safely

- Stopping distance increases with speed and weight of towed load. Travel slowly and allow extra time and distance to stop.
- Total towed weight must not exceed limits specified in towing vehicle operator's manual.
- Excessive towed load can cause loss of traction and loss of control on slopes. Reduce towed weight when operating on slopes.

- Never allow children or others in or on towed equipment.
- Use only approved hitches. Tow only with a machine that has a hitch designed for towing. Do not attach towed equipment except at the approved hitch point.
- Follow the manufacturer's recommendations for weight limits for towed equipment and towing on slopes. Use counterweights or wheel weights as described in the machine operator's manual.
- Do not turn sharply. Use additional caution when turning or operating under adverse surface conditions. Use care when reversing.
- Do not shift to neutral and coast downhill.

### Protect Bystanders

- Keep bystanders away when you operate a towed attachment.
- Before you back machine and attachment, look carefully behind attachment for bystanders.

### Keep Riders Off Towed Attachment

Keep riders off of a towed attachment.

Riders on a towed attachment are subject to injury, such as being struck by objects and being thrown off the attachment during sudden starts, stops and turns.

Riders obstruct the operator's view, resulting in the attachment being used in an unsafe manner.

Keep riders off of hitch bracket.

### Keep Feet From Under Drawbar

Before you disconnect an attachment from machine hitch plate:

- Unload attachment.
- Stop attachment on level ground.
- Stop machine engine.
- Lock machine park brake.
- Block attachment wheels.
- Make sure feet are not under drawbar.

# ASSEMBLY

## Parts in Kit

### Assembly

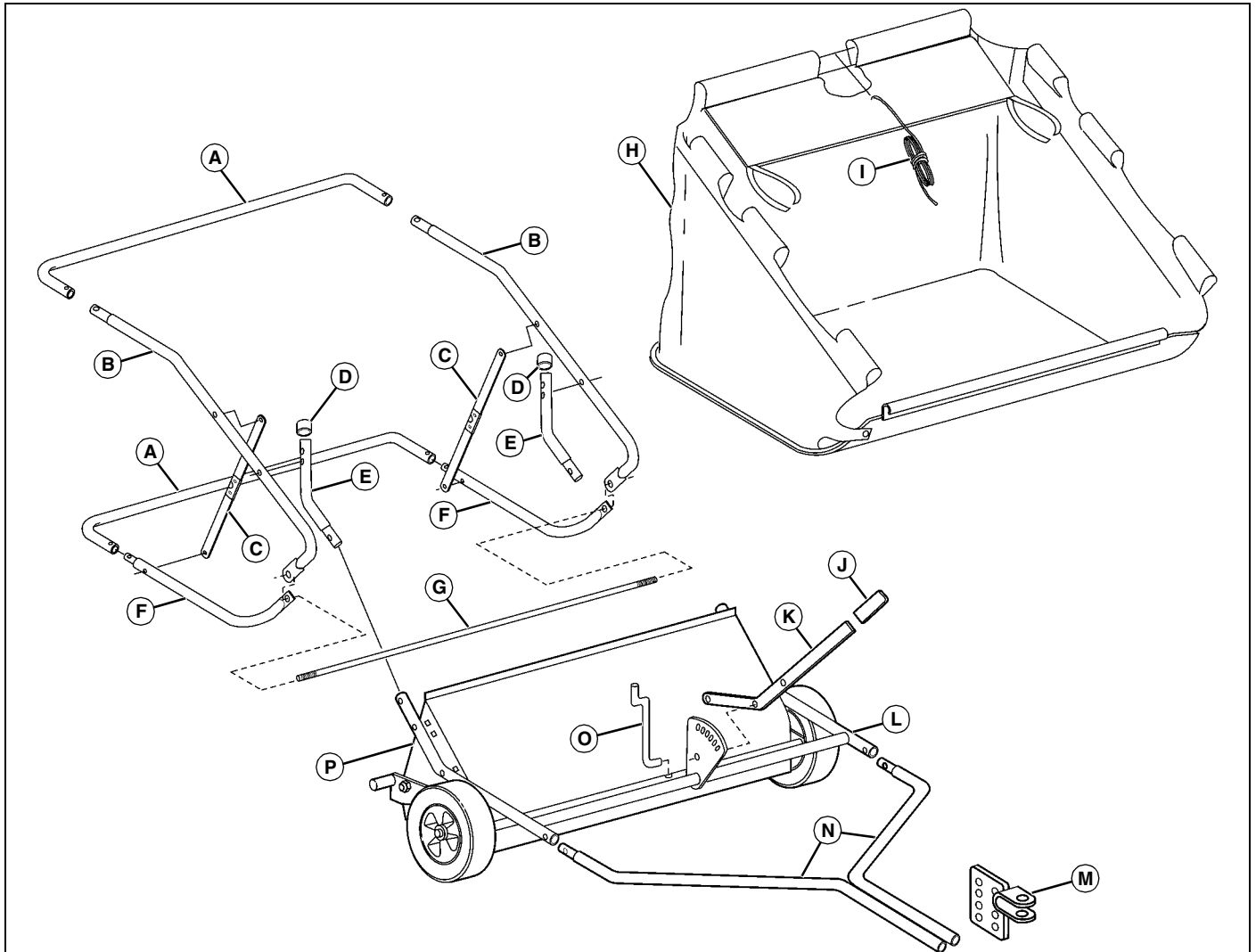

MX34943

Qty.	Description	Qty.	Description
		1	Upper Frame Assembly (L)
2	Rear Tube (A)	1	Hitch Clevis Assembly (M)
2	Upper Tube (B)	2	Tow Tube (N)
2	Spreader Bar Assembly (C)	1	Lift Link (O) (reference, included in Bag of Parts A)
2	Vinyl Cap (D) (reference, included in Bag of parts B)	1	Brush Housing Assembly / Drive Unit (P)
2	Hamper Mount Tube (E)		
2	Lower Tube (F)		
1	Hamper Stop Rod (G)		
1	Hamper, w/ Windscreen (H)		
1	Hamper Pull Rope (I)		
1	Flat Grip (J) (reference, included in Bag of Parts A)		
1	Lift Handle (K)		
			<b>Bag of Parts - Hardware (marked A)</b>
		<b>Qty.</b>	<b>Description</b>
		2	Hex Bolt, 5/16 x 2-1/4 in.
		2	Hex Bolt, 5/16 x 1-1/2 in.
		1	Hex Bolt, 5/16 x 1-3/4 in.
		4	Carriage Bolt, 5/16 x 1-1/2 in.
		4	Screw, 1/4 x 1-1/4 in.

# ASSEMBLY

Qty.	Description
1	Lock Pin
1	Hitch Pin, 1/2 in. diameter.
1	Large Hairpin Cotter
1	Lock Washer, 5/16 in.
2	Flat Washer, 5/16 in.
1	Standard Nut, 5/16 in.
9	Nylock Nut, 5/16 in.
4	Lock Nut, 1/4 in.
4	Push Connector, 5/16 x 5/8 in.
1	Spring
1	Flat Grip
1	Lift Link

## Bag of Parts - Hardware (marked B)

Qty.	Description
2	Bolt, 5/16 x 2-1/4 in.
2	Clevis Pin, 5/16 x 1-3/8 in.
2	Small Hairpin Cotter
4	Special Flat Washer
2	Nylock Nut, 5/16 in.
2	Standard Nut, 3/8 in.
2	Lock Nut, 3/8 in.
2	Vinyl Cap

## Assemble Front Frame and Lift Assembly

**NOTE:** Use Hardware Bag A components for this sequence.

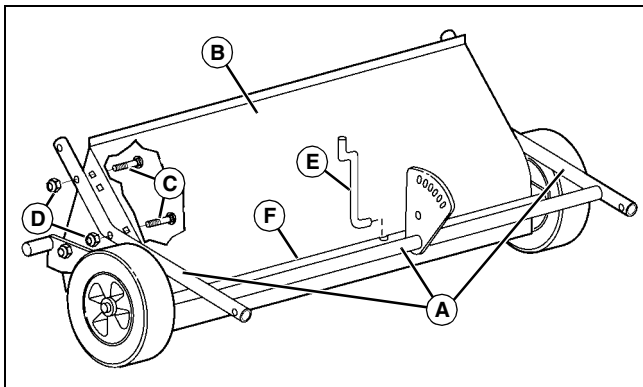

MX33922

1. Align the upper frame assembly (A) with the brush housing assembly (B) and secure on each side with two 5/16 x 1-1/2 in. carriage bolts (C) (installed from the inside, as shown) and 5/16 in. nylock nuts (D). Tighten hardware.

2. Insert lift link (E) into hole in cross tube (F), oriented as shown

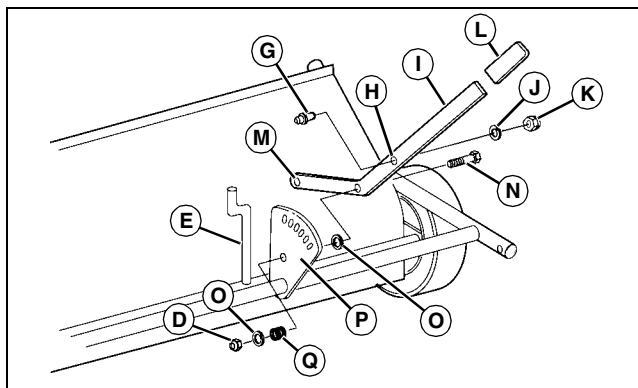

MX33923

3. Insert the threaded end of lock pin (G) into upper hole (H) in lift handle (I) and secure using a 5/16 in. lock washer (J) and 5/16 in. standard nut (K).

4. Install the flat grip (L) on the end of the lift handle.

5. Rotate the lift handle and assemble it to the lift link (E) through the lower hole (M).

6. Install a 5/16 x 1-3/4 in. hex bolt (N) through the middle hole in the lift handle (I), then install a 5/16 in. flat washer (O) onto the hex bolt on the other side of the lift handle, as shown.

7. Align the lift handle against the lock plate (P), with the lock pin in one of the seven index holes at the top of the lock plate and the hex bolt through the lower hole. Secure with spring (Q), 5/16 in. flat washer (O) and 5/16 in. nylock nut (D). Tighten lock nut, then back off as necessary for proper operation.

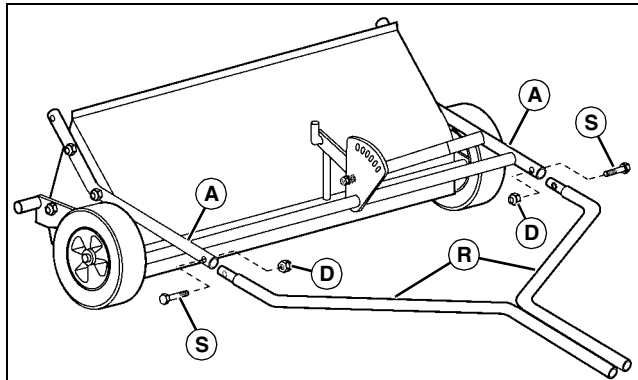

MX33924

8. Install the two tow tubes (R) into the upper frame assembly (A), and secure with two 5/16 x 1-1/2 in. hex bolts (S) inserted from the outside, and 5/16 in. nylock nuts (D) at the inside. Tighten hardware only finger-tight at this time.

# ASSEMBLY

## Assemble Hitch Components

**NOTE: Use Hardware Bag A components for this sequence.**

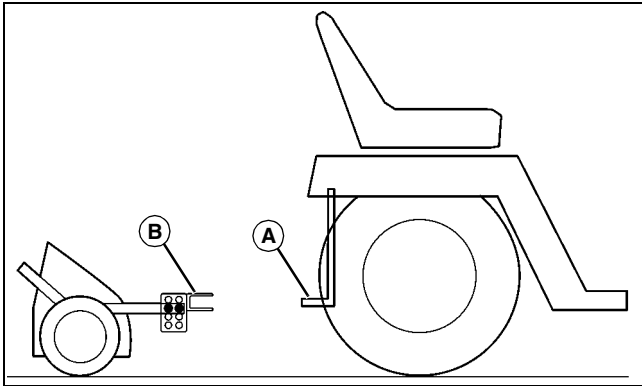

MX33925

1. Park machine on a level, hard surface and measure from the ground to the top of the rear hitch plate (A) or drawbar. This measurement will determine mounting position of hitch clevis assembly (B).

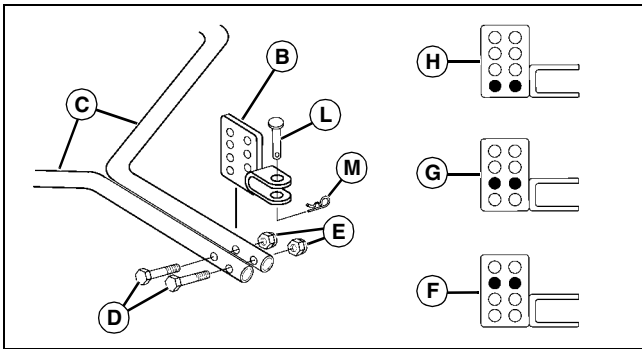

MX33926

**Picture Note: Hitch clevis at bottom.**

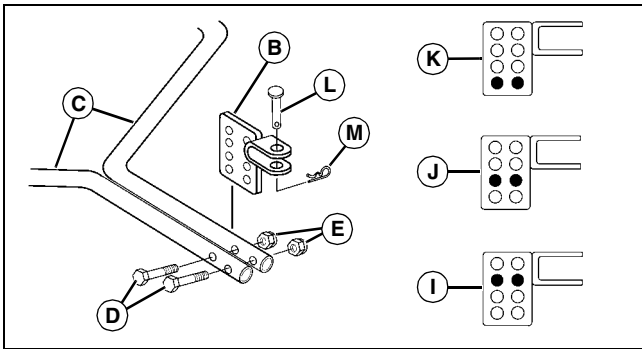

MX33927

**Picture Note: Hitch clevis at top.**

2. Place hitch clevis assembly (B) between the two tow tubes (C) and secure with two 5/16 x 2-1/4 in. hex bolts (D) and 5/16 in. nylock nuts (E). Position hitch plate and mounting holes as follows according to hitch plate or drawbar height:

- a. 15.2cm (6 in.) - Clevis at bottom, hole position (F).
- b. 17.8cm (7 in.) - Clevis at bottom, hole position (G).
- c. 20.3cm (8 in.) - Clevis at bottom, hole position (H).
- d. 22.9cm (9 in.) - Clevis at top, hole position (I).
- e. 25.4cm (10 in.) - Clevis at top, hole position (J).
- f. 27.9cm (11 in.) - Clevis at top, hole position (K).

- 3. Tighten hitch clevis hardware and hardware securing tow tubes to upper frame.
- 4. Insert hitch pin (L) into hitch clevis and secure with large hairpin cotter (M) to store until needed.

## Assemble Hamper Components

**NOTE: Use Hardware Bags A and B components for this sequence.**

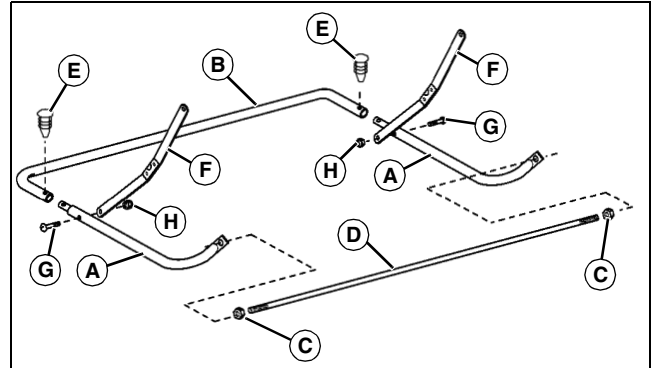

MX33928

- 1. Install two lower tubes (A) into one of the rear tubes (B). Align curved ends of lower tubes upward, as shown, when assembling components.
- 2. Thread a 3/8 in. standard nut (C) approximately 19mm (3/4 in.) onto each end of hamper stop rod (D), then assemble the stop rod between the two lower tubes.
- 3. Secure lower tubes to rear tube with 5/16 x 5/8 in. push connector (E).
- 4. Assemble a spreader bar assembly (F) at the inside of each lower tube, with the shorter legs toward the hamper bottom. The hinged spreader bars should be installed so that the hinge pivots to the front as they are collapsed for storage, as shown. Secure with 1/4 x 1-1/4 in. screws (G) installed from the outside and 1/4 in. locknuts (H) at the inside.

# ASSEMBLY

**NOTE: Flip attached windscreen behind hamper during hamper component assembly.**

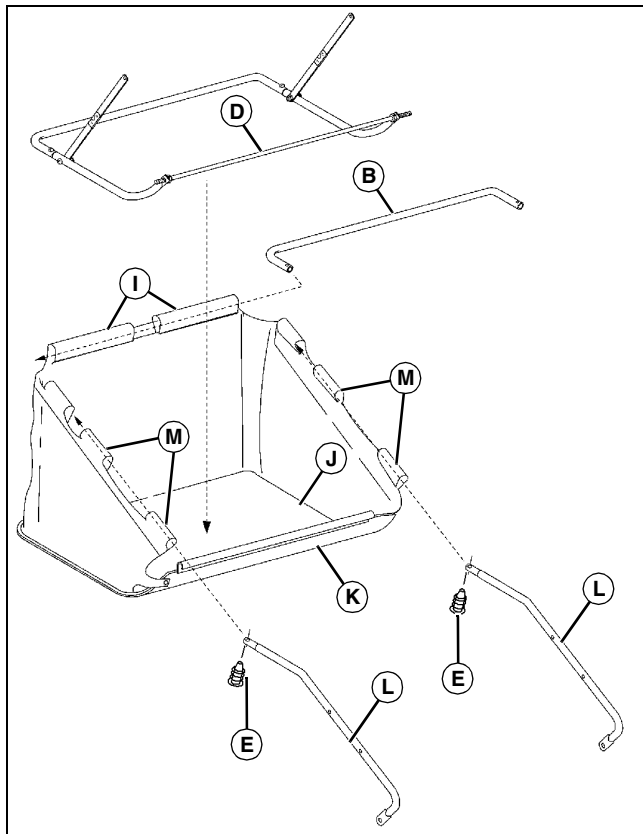

MX33929

5. Feed the remaining rear tube (B) carefully through the sewn pockets (I) at the rear of the hamper. The material will have to be bunched together as the tube is fed through.

6. Place the previously assembled lower tubes, rear tube, spreader bars and hamper stop rod into the bottom of the hamper and adjust to fit tightly against the hamper base (J).

7. Lift the front of the hamper base with formed plastic channel (K) up over the hamper stop rod (D) and then press it down until it snaps over the hamper stop rod to secure.

8. Insert the straight ends of the upper tubes (L) into the sewn pockets (M) at the sides of the hamper and assemble them into the rear tube (B) at the top of the hamper. Position the curved ends of the upper tubes so they point down, as shown, and secure the upper tubes to the rear tube with two 5/16 x 5/8 in. push connectors (E).

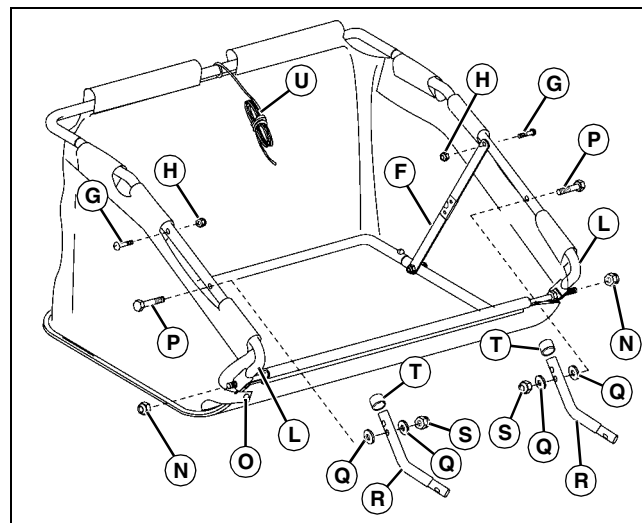

MX34951

9. Assemble the curved ends of the upper tubes (L) over the ends of the hamper stop rod and secure with 3/8 in. locknuts (N).

10. Engage snaps (O) at each corner of the hamper.

11. Straighten and lock spreader arms (F), then open hamper fully. Assemble the spreader arms to the upper tubes, securing with 1/4 x 1-1/2 in. round head screws (G) from the outside, through existing holes in the sewn pocket of the hamper and upper tube, and 1/4 in. locknuts (H) on the inside.

12. Insert a 5/16 x 2-1/2 in hex bolt (P), from the outside, through an existing hole in each upper tube in an area exposed by a cutout in the sewn pocket of the hamper.

**NOTE: If two mounting holes are present at the curved end of the hamper mount tubes, install the hex bolt through the lower hole.**

13. Assemble a 5/16 in. special flat washer (Q) and hamper mount tube (R) on the hex bolt (P) at the inside of each upper tube, securing with a 5/16 in. special flat washer (Q) and 5/16 in. nylock nut (S). Do not overtighten hardware, hamper mount tube must be able to pivot freely.

14. Install a vinyl cap (T) over the pivot end of each hamper mount tube, as shown.

15. Tie hamper pull rope (U) to upper rear tube where sewn pocket of hamper is cut away.

# INSTALLING

## Assemble Hamper to Sweeper

**NOTE: Use Hardware Bag B components for this sequence.**

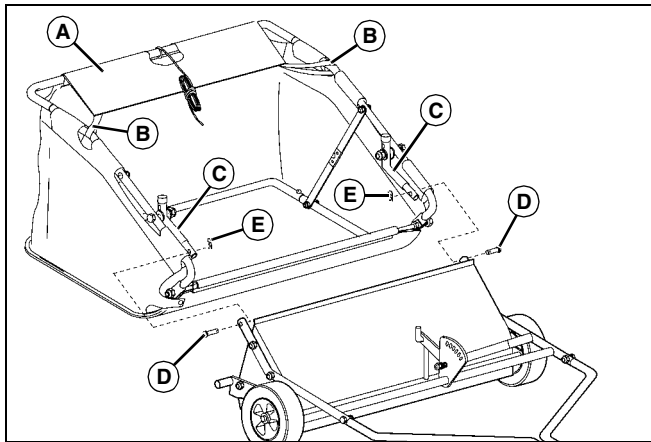

MX34944

1. Flip windscreen (A) to the front over the top of the hamper and wrap hook and loop fastener strips (B) around upper hamper tube on each side, at first cut-out area, to secure.
2. Insert the end of each hamper mounting tube (C) into the upper frame assembly of the sweeper on each side and secure with 5/16 x 1-3/8 in. clevis pins (D) installed from the outside and small hairpin cotters (E) at the inside.

## Installing

### Attaching Lawn Sweeper

1. Park machine safely. See "Parking Safely" in Safety section.

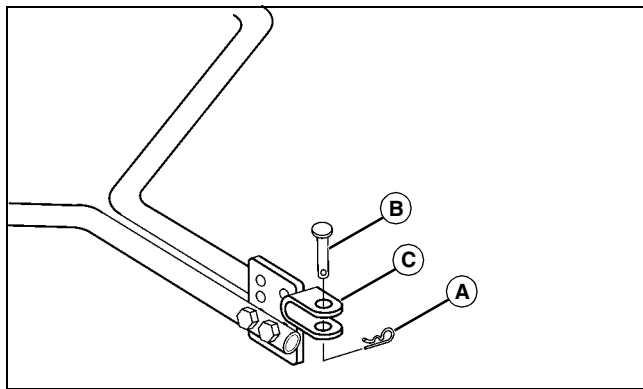

MX33935

2. Remove large hairpin cotter (A) and hitch pin (B) from hitch clevis (C) of sweeper or other storage location.
3. Pull sweeper forward and position hitch clevis to straddle machine rear hitch plate or drawbar (not shown). Align all hitch pin holes, then install hitch pin down through hitch clevis and machine hitch, securing with large hairpin cotter.

## Removing and Storing

### Removing

**NOTE: Refer to illustration in the Installing Section, earlier in this manual.**

1. Park machine safely. See "Parking Safely" in the Safety section.
2. Remove large hairpin cotter from hitch pin.
3. Hold sweeper tow tubes to remove pressure from hitch pin, then remove hitch pin from hitch clevis and rear hitch plate or drawbar on machine.
4. Pull or push sweeper backward to disengage hitch clevis from machine hitch, install hitch pin in hitch clevis for storage and secure with large hairpin cotter.

### Storing

The sweeper can be tipped upright and stored against a wall using a minimum of space:

1. Remove any loose material from hamper and brush housing / drive assembly. The sweeper should be clean and dry before configuring for storage.
2. Remove small hairpin cotters and clevis pins securing hamper assembly to brush housing and remove hamper assembly.
3. Unlock spreader bars and collapse hamper.
4. Remove large hairpin cotter and hitch pin from hitch clevis, if stored there.
5. Move lift handle to the index hole farthest forward (toward the tow tubes).

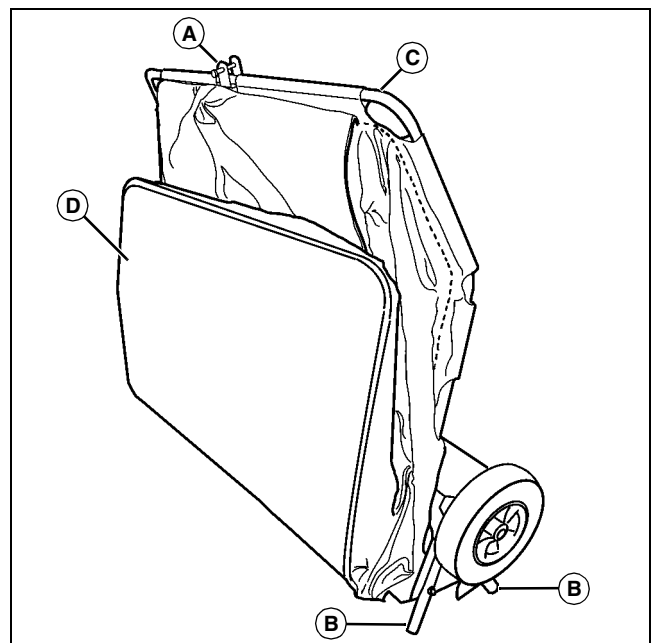

MX34092

6. Roll sweeper to desired storage area, lift hitch clevis (A) to pivot sweeper to vertical position and resting on the tubes (B) at rear of sweeper (bottom of sweeper should face wall).
7. Lift the collapsed hamper assembly by the rear tubes, positioning the middle of the upper rear tube (C) at the center hamper cut-out over the opening in the hitch clevis (the inside of the hamper faces the lift handle and tow tubes, and the bottom (D) of the hamper facing outward). Lower the hamper to rest in the hitch clevis.
8. Replace hitch pin and large hairpin cotter.

# OPERATING

## Operating

### Adjusting Brush Height

*NOTE: Setting brush height too low for sweeping conditions causes excessive wheel slippage. For maximum performance, adjust brush height as high as possible for the material and conditions.*

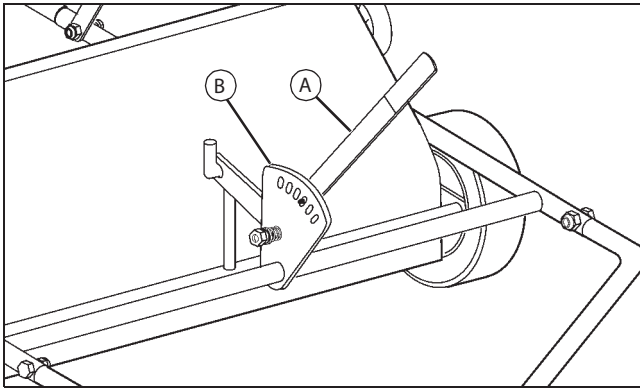

MX34083

1. Pivot lift handle (A) away from lock plate (B) to disengage lock pin in handle from index hole in lock plate.
2. Move lift handle forward (away from brush housing) to raise brush height, or back (toward brush housing) to lower brush height. Align lock pin with appropriate index hole in lock plate and release lift handle to secure height adjustment.

Brush Height	Sweeping Conditions
25mm (1 in.) to 50mm (2 in.)	Mowed lawns under normal conditions, or light leaves.
50mm (2 in.) to 75mm (3 in.)	High grass, heavy leaves or heavy grass clippings.

### Leveling Hamper

After the brush height has been set, the hamper stop assembly may have to be adjusted so that the hamper assembly is level.

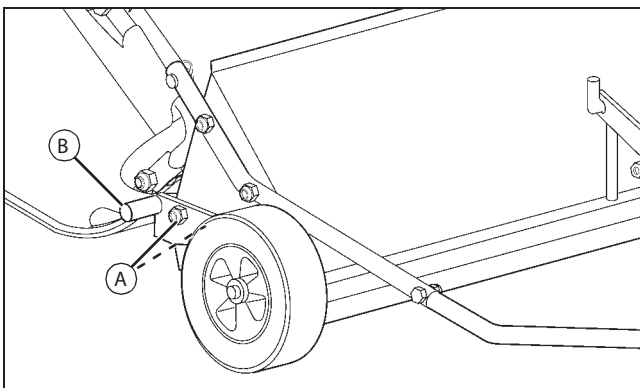

MX34946

Picture Note: Right front view shown.

1. Loosen slightly two nuts (A) securing each side of hamper stop bracket to brush housing. The rear bracket mounting holes in the brush housing are slotted, allowing the bracket to be pivoted up or down for adjustment.

2. Tap the hamper stop tube (B) up or down to adjust the resting position of the hamper so that it is approximately level. Tighten hardware.

### Operating Speed

The operating ground speed of the sweeper has a direct effect on how swept material is thrown into the hamper. Material will be thrown farther toward the back of the hamper as ground speed increases.

Operate the sweeper at a ground speed that will throw material to the back of the hamper. Under normal conditions, that will be 5-6.5km/h (3-4 mph), approximately the speed of a brisk walk.

### Emptying Hamper

*NOTE: Avoid overfilling hamper, especially when sweeping freshly mowed grass or other moist material. Extremely heavy loads will be difficult to dump.*

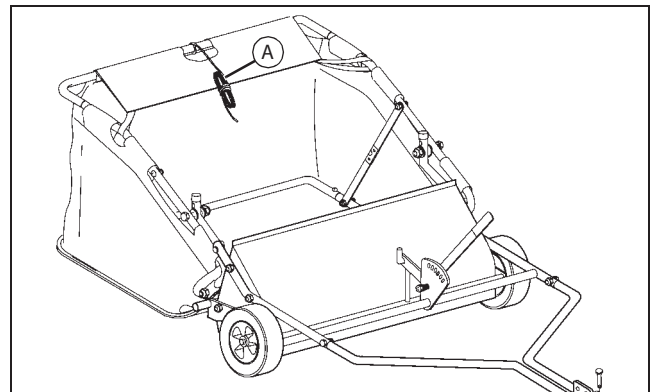

MX34945

The hamper pull rope (A) can be routed to the tow machine operator's area and temporarily secured. The operator can then empty the hamper while seated in the operating position.

To empty hamper:

1. Stop machine.
2. Engage park brake.
3. Pull on hamper pull rope (A) to tilt hamper forward / upward, allowing material to exit the opening at the front of the hamper.

## Service Miscellaneous

### General Maintenance

*NOTE: Never allow wet material to remain in hamper for extended periods of time.*

- Clean material from hamper and brush housing after use. Maintain the unit in a clean, dry condition for best results.
- Check all moving parts periodically for freedom of movement. Routine lubrication is not required, if a problem exists lightly lubricate problem area or see your John Deere dealer to determine cause of problem.
- Check all external fasteners for tightness.
- Inspect for rust on painted metal surfaces. Sand lightly and touch up damaged area with enamel paint, as necessary.



# GETTING QUALITY SERVICE

---

---

## Getting Quality Service

### John Deere Quality Continues with Quality Service

John Deere provides a process to handle your questions or problems, should they arise, to ensure that product quality continues with quality parts and service support.

Follow the steps below to get answers to any questions you may have about your product.

1. Refer to your attachment and machine operator manuals.
2. In North America or Canada, call John Deere Special Services at 1-866-218-8622 and provide product serial number (if available) and model number.

# NOTES

---

---

## Free Manuals Download Website

<http://myh66.com>

<http://usermanuals.us>

<http://www.somanuals.com>

<http://www.4manuals.cc>

<http://www.manual-lib.com>

<http://www.404manual.com>

<http://www.luxmanual.com>

<http://aubethermostatmanual.com>

Golf course search by state

<http://golfingnear.com>

Email search by domain

<http://emailbydomain.com>

Auto manuals search

<http://auto.somanuals.com>

TV manuals search

<http://tv.somanuals.com>