

# **SERVICE MANUAL**

## **SEWING MACHINE MODELS**

**385. 11602090**

**385. 12708090**

**385. 12710090**

**385. 12712090**

**385. 12714090**

TABLE OF CONTENTS

1.	LOCATE AND IDENTIFY THE PARTS .....	1
2.	WIND THE BOBBIN .....	2
3.	PREPARE YOUR TOP THREAD .....	3
4.	STITCH SELECTOR/STITCH LENGTH CONTROLS .....	4-1 & 4-2
5.	REMOVING COVERS AND ENCLOSURES .....	5-1 & 5-2
6.	ADJUSTMENT .....	6 - 20
	TOP TENSION .....	6
	BOBBIN TENSION .....	7
	PRESSER BAR HEIGHT AND ALIGNMENT .....	8
	ZIG-ZAG SYNCHRONIZATION .....	9
	STITCH WIDTH ADJUSTMENT .....	10
	STRETCH STITCH BALANCE .....	11
	FEED DOG HEIGHT .....	12
	NEEDLE CLEARANCE TO SHUTTLE .....	13
	NEEDLE BAR HEIGHT .....	14
	NEEDLE TIMING TO SHUTTLE .....	15
	ZERO FEEDING .....	16
	AUTOMATIC MECHANISM .....	17
	DISENGAGEMENT OF FOLLOWER .....	18
	MOTOR BELT TENSION .....	19
	WIRING .....	20
7.	OILING .....	21
8.	SPECIAL TOOLS REQUIRED .....	22-1 & 22-2

LOCATE AND IDENTIFY THE PARTS

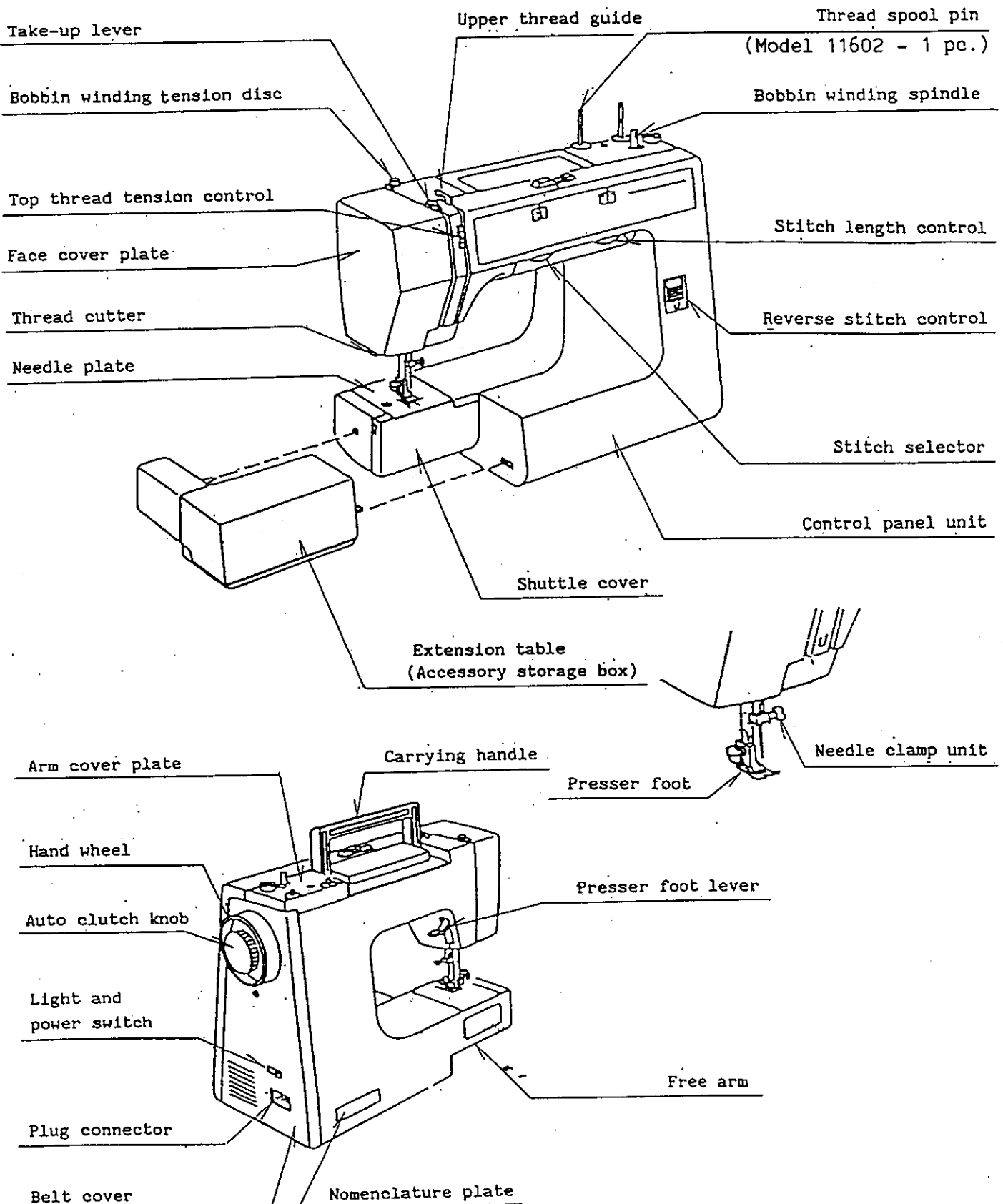

WIND THE BOBBIN

1. RELEASE CLUTCH BY TURNING THE CLUTCH KNOB (C) INSIDE THE HAND WHEEL TOWARD YOU.
2. DRAW THREAD FROM SPOOL THROUGH BOBBIN WINDING TENSION DISCS (A).
3. PULL END OF THREAD THROUGH HOLE IN BOBBIN AS SHOWN.  
PLACE BOBBIN ONTO BOBBIN WINDING SPINDLE (B) WITH END OF THREAD COMING FROM THE TOP OF THE BOBBIN.  
PUSH BOBBIN WINDING SPINDLE TO THE RIGHT UNTIL IT CLICKS.
4. HOLDING THE END OF THREAD, START MACHINE. WHEN BOBBIN IS SLIGHTLY FILLED, SNIP OFF.
5. WIND THREAD UNTIL BOBBIN STOPS. REMOVE BOBBIN. CLIP THREAD.  
TURN CLUTCH KNOB AWAY FROM YOU WHILE HOLDING HAND WHEEL.

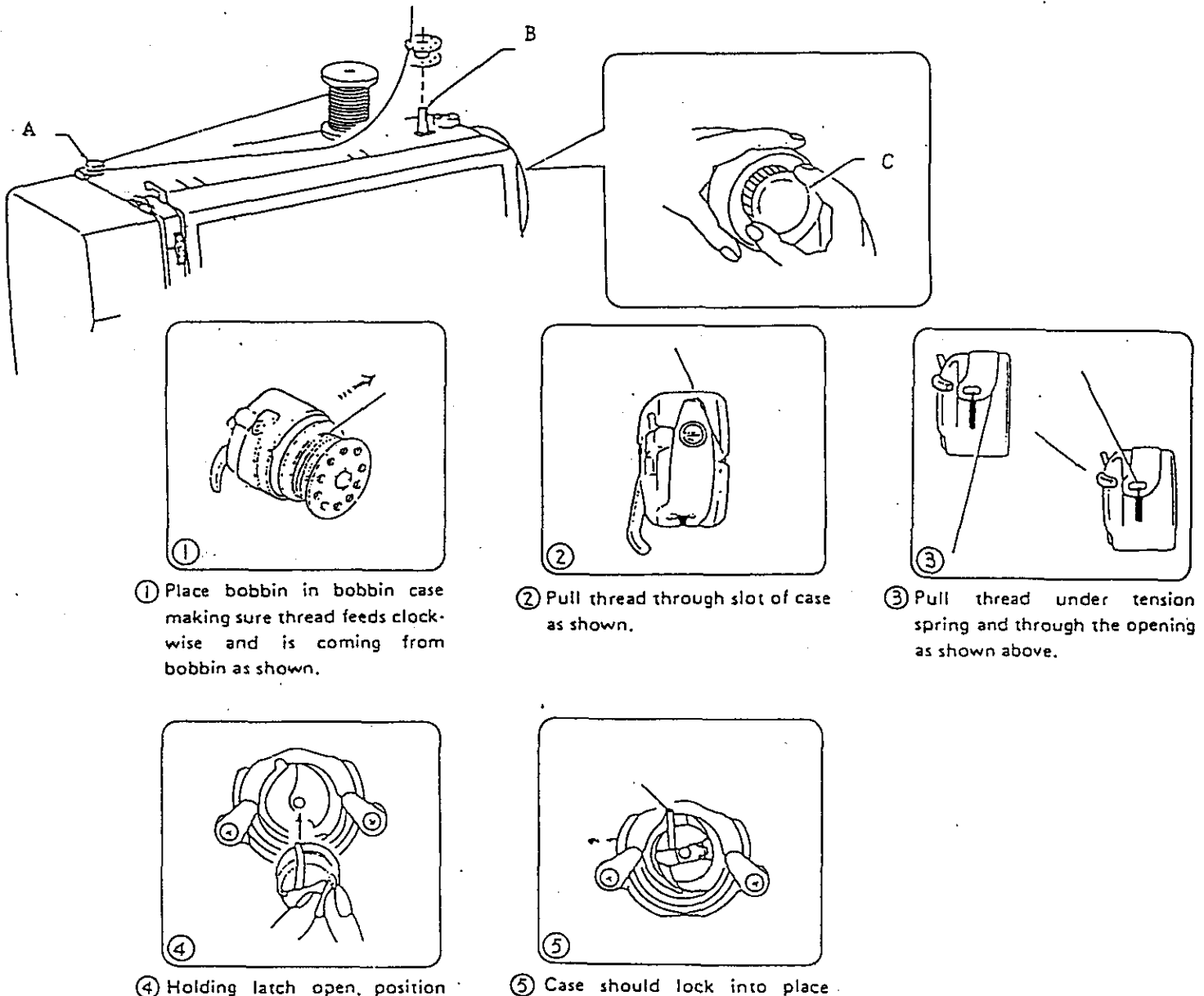

PREPARE YOUR TOP THREAD

THE NUMBERED STEPS BELOW FOLLOW THE NUMBERS ON THE ILLUSTRATIONS.  
DOTTED LINES SHOW PLACES WHERE THE THREAD LOOPS AND THEN IS PULLED TIGHT.

RAISE THE TAKE-UP LEVER TO ITS HIGHEST POSITION BY TURNING THE HAND WHEEL TOWARD YOU.  
RAISE THE PRESSER FOOT LEVER.  
PLACE SPOOL ON THE SPOOL PIN WITH THREAD COMING FROM THE BACK OF THE SPOOL.

1. DRAW THREAD THROUGH THE THREAD GUIDE.
2. HOLDING THREAD TAUT WITH RIGHT HAND, DRAW THREAD DOWN INTO THE TENSION AREA AND THEN AROUND THE CHECK SPRING HOLDER.
3. FIRMLY DRAW THREAD UP AND THROUGH THE TAKE-UP LEVER FROM RIGHT TO LEFT.
4. DRAW THREAD DOWN AGAIN AND SLIP IT INTO THE NEEDLE BAR THREAD GUIDE.
5. THREAD NEEDLE FROM FRONT TO BACK.

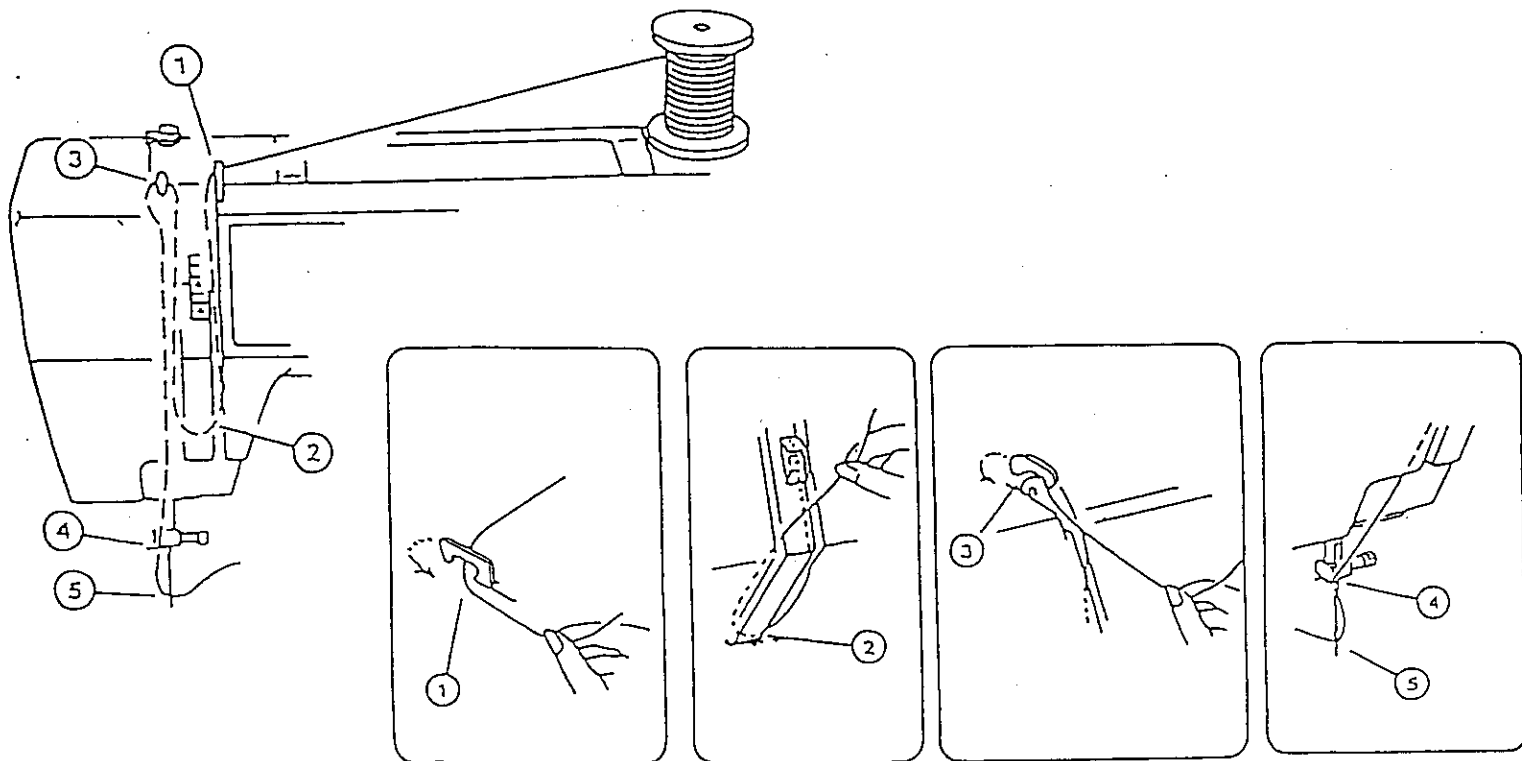

REMOVING COVERS AN ENCLOSURES

FACE COVER PLATE

1. REMOVE THE SCREW (A).
2. TAKE THE FACE COVER PLATE OFF.

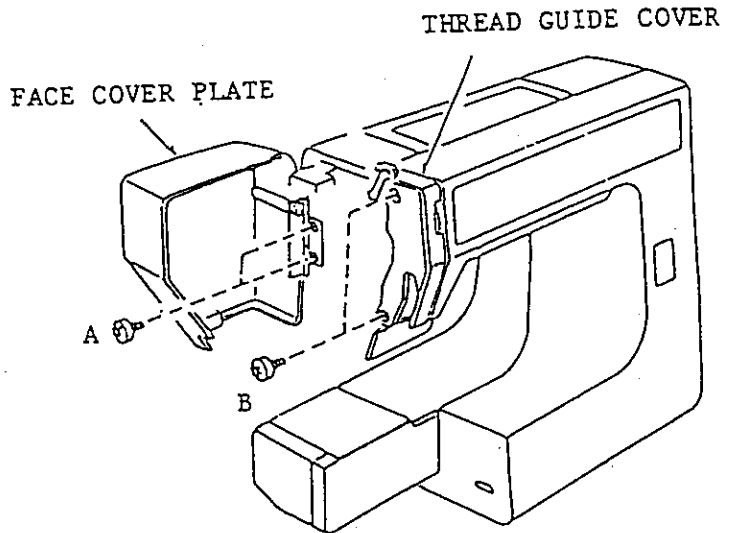

THREAD GUIDE COVER

1. REMOVE THE SCREW (B).
2. TAKE THE THREAD GUIDE COVER OFF.

BELT COVER

1. REMOVE THE SCREWS (C) AND (D).
2. TAKE THE BELT COVER OFF.

SCREW	SIZE	TYPE
A	4x6	+--Pan head
B	4x12	+--Binding head
C	4x20	+--Binding head
D	4x12B	+ Pan head self tapping

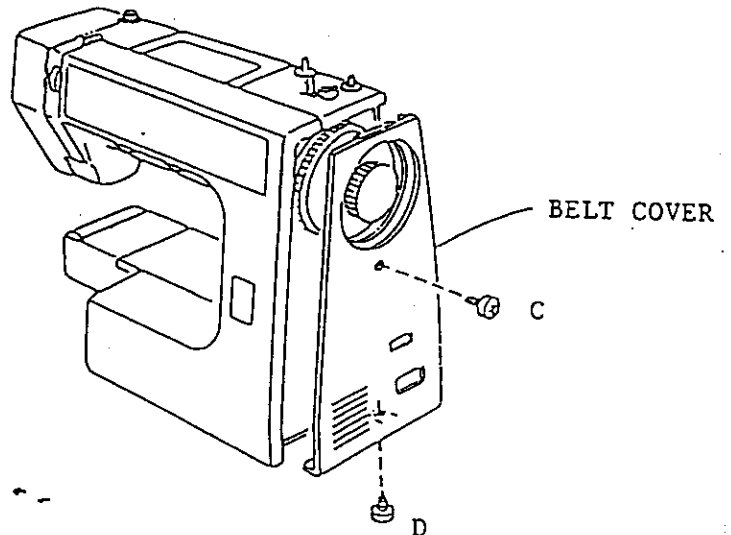

REMOVING COVERS AN ENCLOSURES

ARM COVER PLATE

1. REMOVE THE SCREW (H).
2. TAKE THE ARM COVER PLATE OFF.

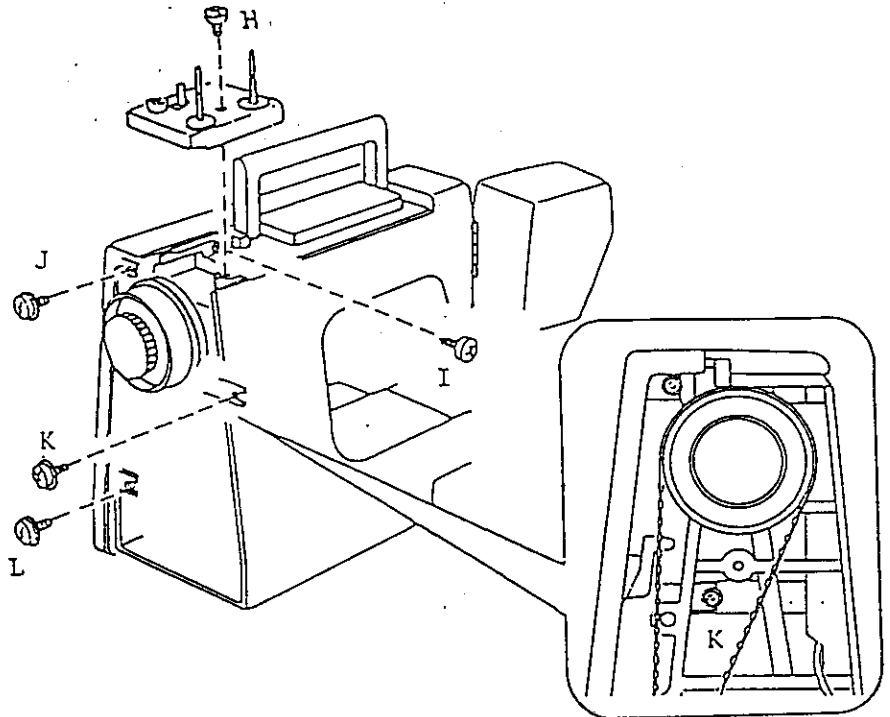

CONTROL PANEL UNIT

1. LOOSEN SCREW (K) INSIDE MACHINE.
2. REMOVE SCREW (G) AND (I).
3. LOOSEN SCREW (E) (F) (J) (L) (N) (O).
4. LOOSEN SCREW (M) INSIDE MACHINE.
5. CAREFULLY EASE CONTROL PANEL OFF. NO FORCE WILL BE NECESSARY.

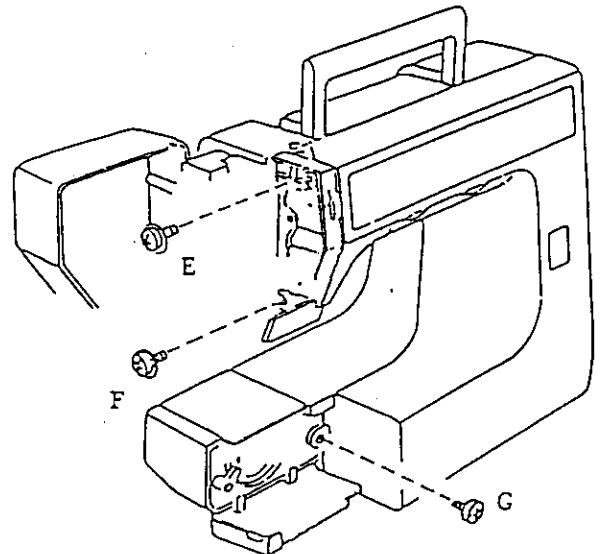
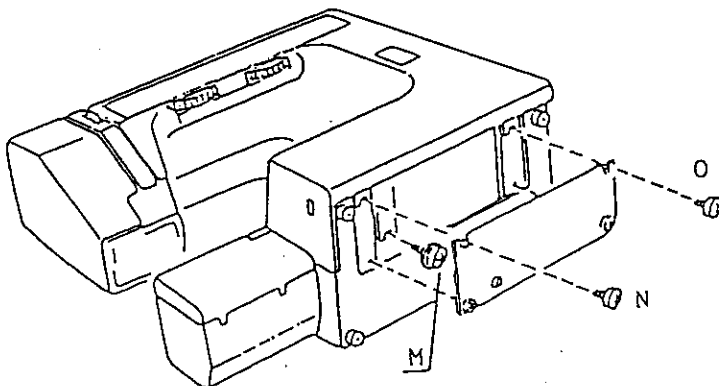

SCREW	SIZE	TYPE
H	4x20	--Binding head
I	4x12B	+ Pan head self tapping
G	4x8	--Binding head

TOP TENSION

USE SOFT COTTON THREAD #50

- CHECK:
1. SET THE TOP THREAD TENSION CONTROL AT 3 AND RAISE THE PRESSER FOOT.
  2. PASS THE THREAD (A) BETWEEN TENSION DISCS AND DRAW THE THREAD (A) DOWN AROUND THE CHECK SPRING HOLDER.
  3. LOWER THE PRESSER FOOT AND BRING THE THREAD (A) UP.
  4. TOP TENSION SHOULD BE 65 - 95G WHEN PULLING THE THREAD (A) IN THE DIRECTION OF "B".

- ADJUSTMENT:
1. REMOVE THE CONTROL PANEL UNIT.
  2. TURN THE ADJUSTING NUT (C) IN THE DIRECTION OF "D" WHEN THE TOP TENSION IS TOO TIGHT.  
TURN THE ADJUSTING NUT (C) IN THE DIRECTION OF "E" WHEN THE TOP TENSION IS TOO LOOSE.
  3. RECHECK THE TOP TENSION AND READJUST IF NECESSARY.

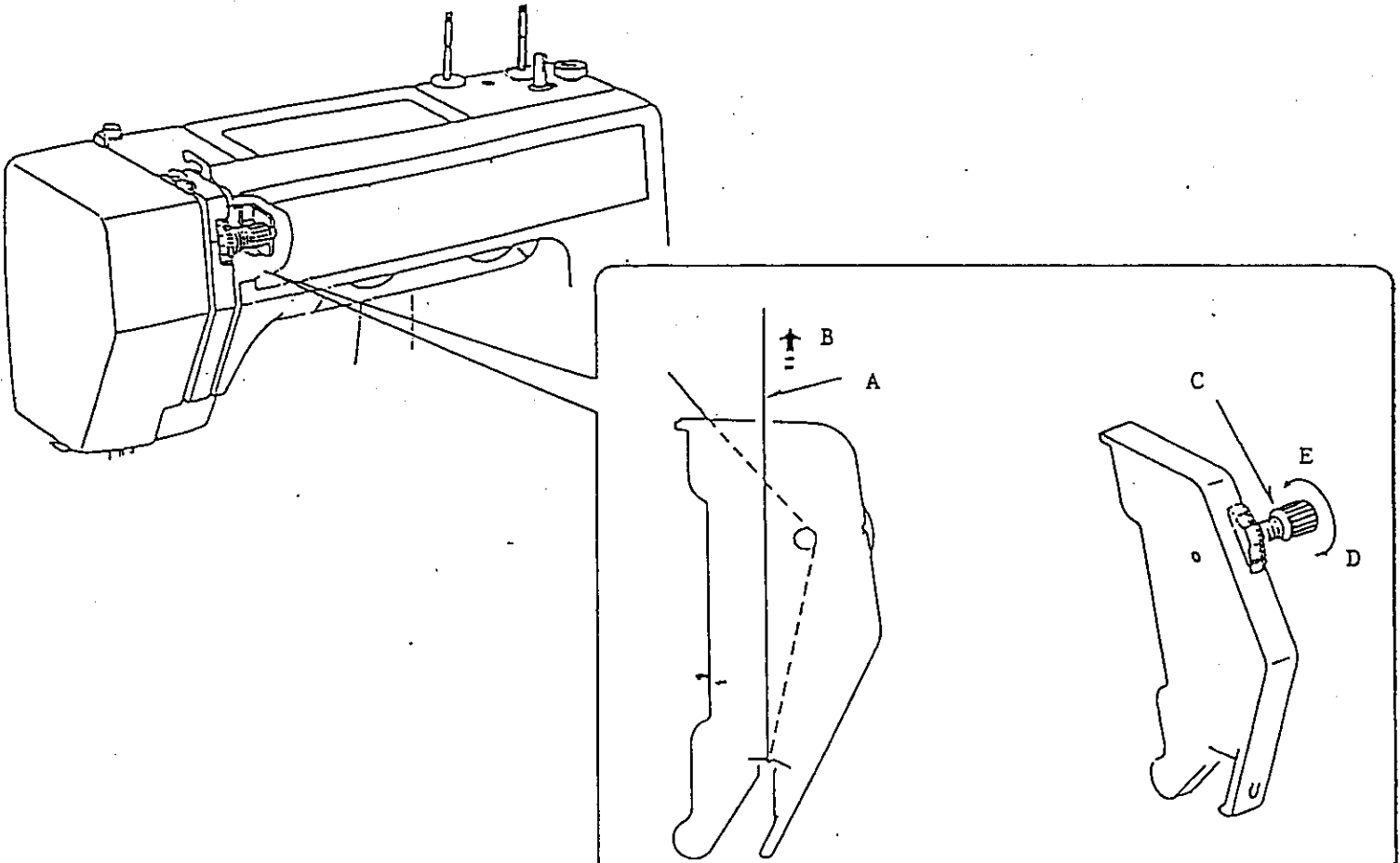



BOBBIN TENSION

USE SOFT COTTON THREAD #50

CHECK:

1. PUT THE BOBBIN IN THE BOBBIN CASE AND PASS THE THREAD (A).
2. BOBBIN TENSION SHOULD BE 45 - 55G WHEN PULLING THE THREAD (A) IN THE DIRECTION OF "B".

ADJUSTMENT:

1. TURN THE ADJUSTING SCREW (C) IN THE DIRECTION OF "D" WHEN THE BOBBIN TENSION IS TOO TIGHT.
2. TURN THE ADJUSTING SCREW (C) IN THE DIRECTION OF "E" WHEN THE BOBBIN TENSION IS TOO LOOSE.

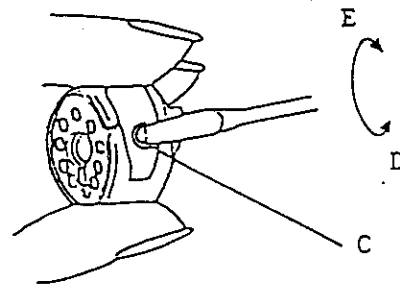
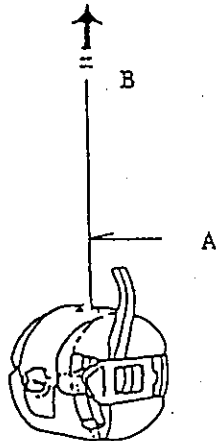

PRESSER BAR HEIGHT AND ALIGNMENT

CHECK:

1. RAISE THE PRESSER FOOT LEVER (A).
2. THE DISTANCE BETWEEN THE PRESSER FOOT (D) AND THE NEEDLE PLATE (E) SHOULD BE 6.0 MM (0.24").

ADJUSTMENT:

1. REMOVE THE SCREW (B) AND TAKE THE LAMP SOCKET OFF.
2. RAISE THE PRESSER FOOT LEVER AND LOOSEN THE SCREW (C) ON THE PRESSER BAR HOLDER.

ADJUST THE DISTANCE BETWEEN THE PRESSER FOOT (D) AND THE NEEDLE PLATE (E) TO 6.0 MM (0.24").

3. TIGHTEN THE SCREW (C) SECURELY.
4. TIGHTEN THE SCREW (B) TO SECURE THE LAMP SOCKET.

NOTE: WHEN YOU TIGHTEN THE SCREW (B), MAKE SURE THAT BOTH SIDE OF THE PRESSER FOOT ARE PARALLEL TO THE FEED DOG SLOTS (F) ON THE NEEDLE PLATE.

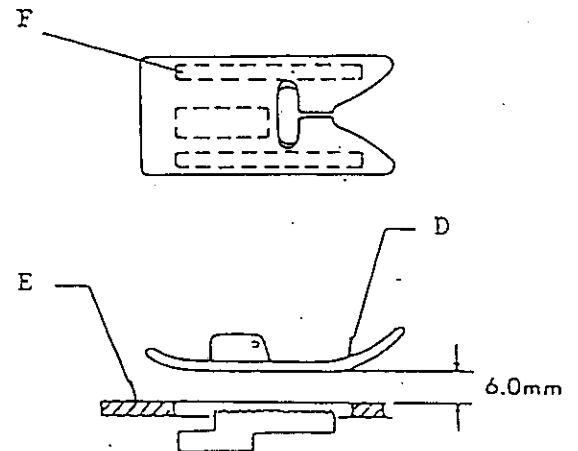
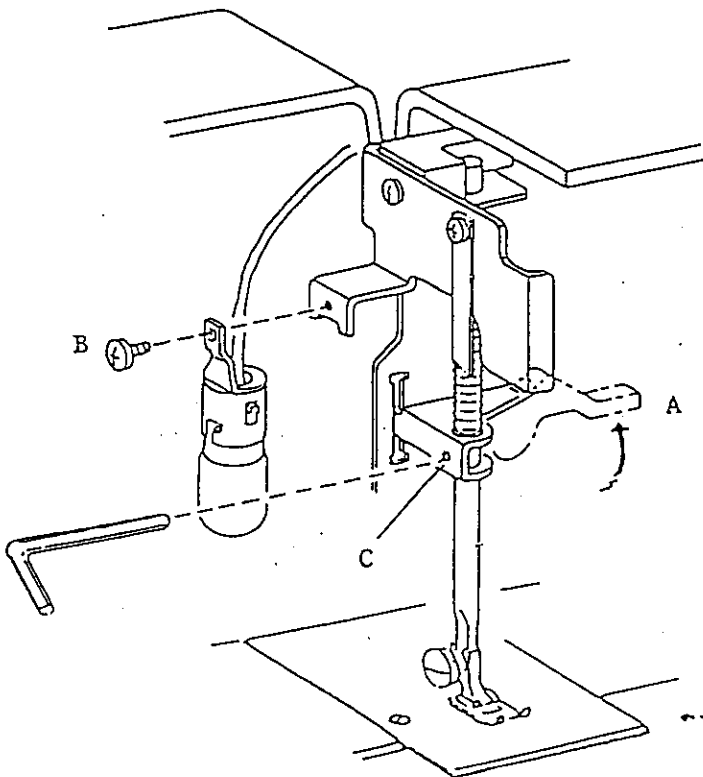

SCREW	SIZE	TYPE
B	4x6	+ -Binding head

ZIG-ZAG SYNCHRONIZATION

MACHINE SETTING: 1. STITCH SELECTOR : [  ] (MAXIMUM)

- CHECK:
1. TURN THE HANDWHEEL TOWARD YOU BY HAND.
  2. THE NEEDLE SHOULD START ITS SIDWARD MOVEMENT AT 2.00 MM - 3.00 MM (0.08" - 0.12") ABOVE THE NEEDLE PLATE.

- ADJUSTMENT:
1. REMOVE THE ARM COVER PLATE, BELT COVER AND CONTROL PANEL UNIT.
  2. LOOSEN THE SCREWS (A) AND (B) ON THE WORM GEAR (C).
  3. HOLD THE WORM GEAR (C) TO PREVENT TURNING AND ADJUST THE WORM GEAR'S ANGLE BY TURNING THE HAND WHEEL IN EITHER DIRECTION SO THAT THE NEEDLE STARTS ITS SIDWARD MOVEMENT AT 2.00 MM - 3.00 MM (0.08" - 0.12") ABOVE THE NEEDLE PLATE.
  4. TIGHTEN THE SCREWS (A) AND (B) SECURELY.
  5. ATTACH THE CONTROL PANEL UNIT, BELT COVER AND ARM COVER PLATE.

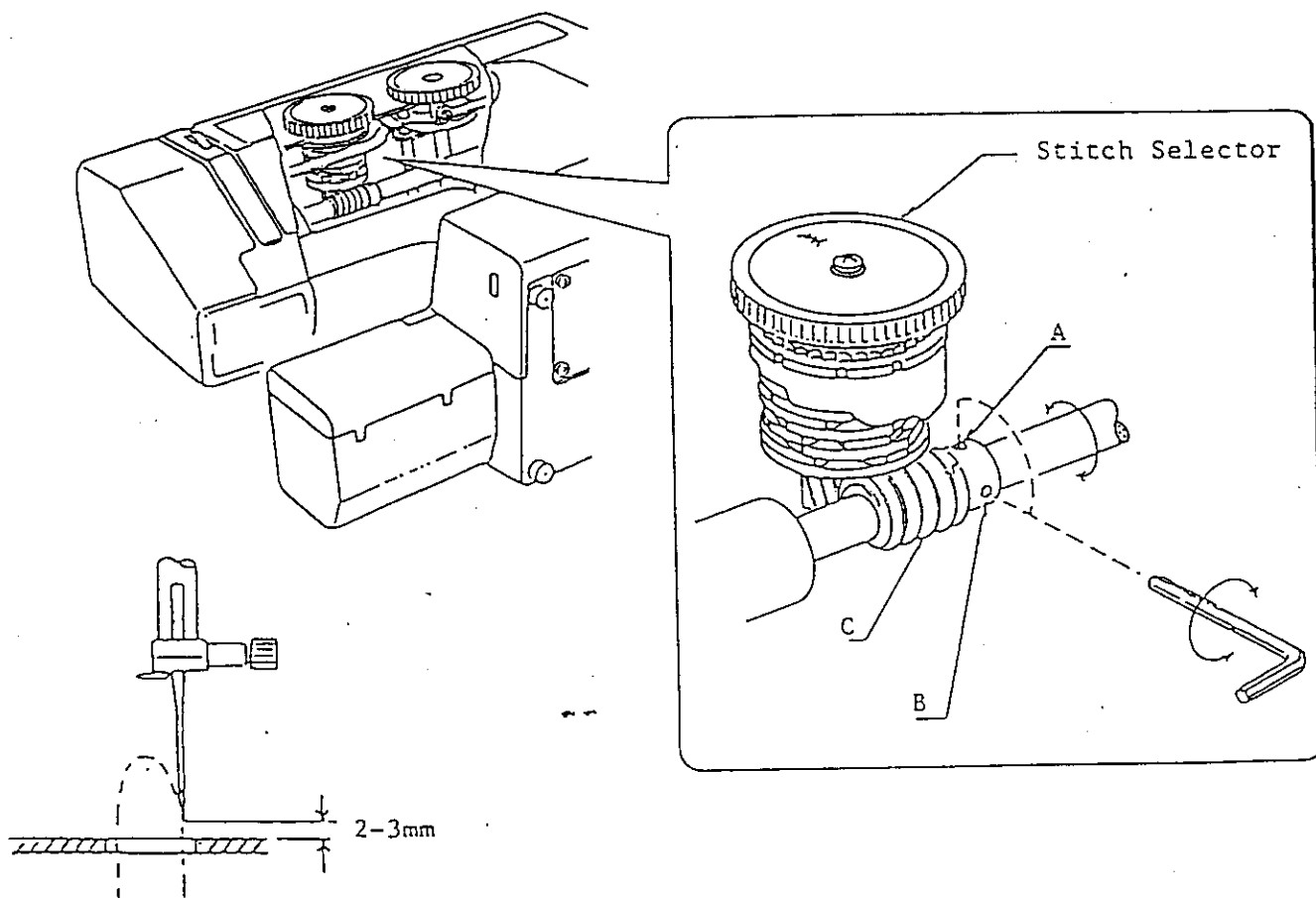

STITCH WIDTH ADJUSTMENT

MACHINE SETTING: 1. STITCH SELECTOR : [  ] (MAXIMUM)

CHECK:

1. TURN THE HANDWHEEL TOWARD YOU BY HAND.
2. THE NEEDLE SHOULD NOT HIT THE NEEDLE PLATE AND THE DISTANCES (A AND B) BETWEEN THE NEEDLE AND THE EDGE OF THE NEEDLE PLATE SHOULD BE EQUAL.

ADJUSTMENT:

1. TURN THE ECCENTRIC PIN (D) IN EITHER DIRECTION UNTIL THE DISTANCE (A) BECOMES THE SAME AS THE DISTANCE (B) AS ILLUSTRATED BELOW.
2. TIGHTEN THE HEXAGON SOCKET SCREW (C) SECURELY.
3. REPLACE THE ZIGZAG PRESSER FOOT WITH THE STRAIGHT STITCH FOOT.  
SET THE STITCH SELECTOR AT [  ] AND MAKE SURE THE NEEDLE DOES NOT HIT THE NEEDLE PLATE.

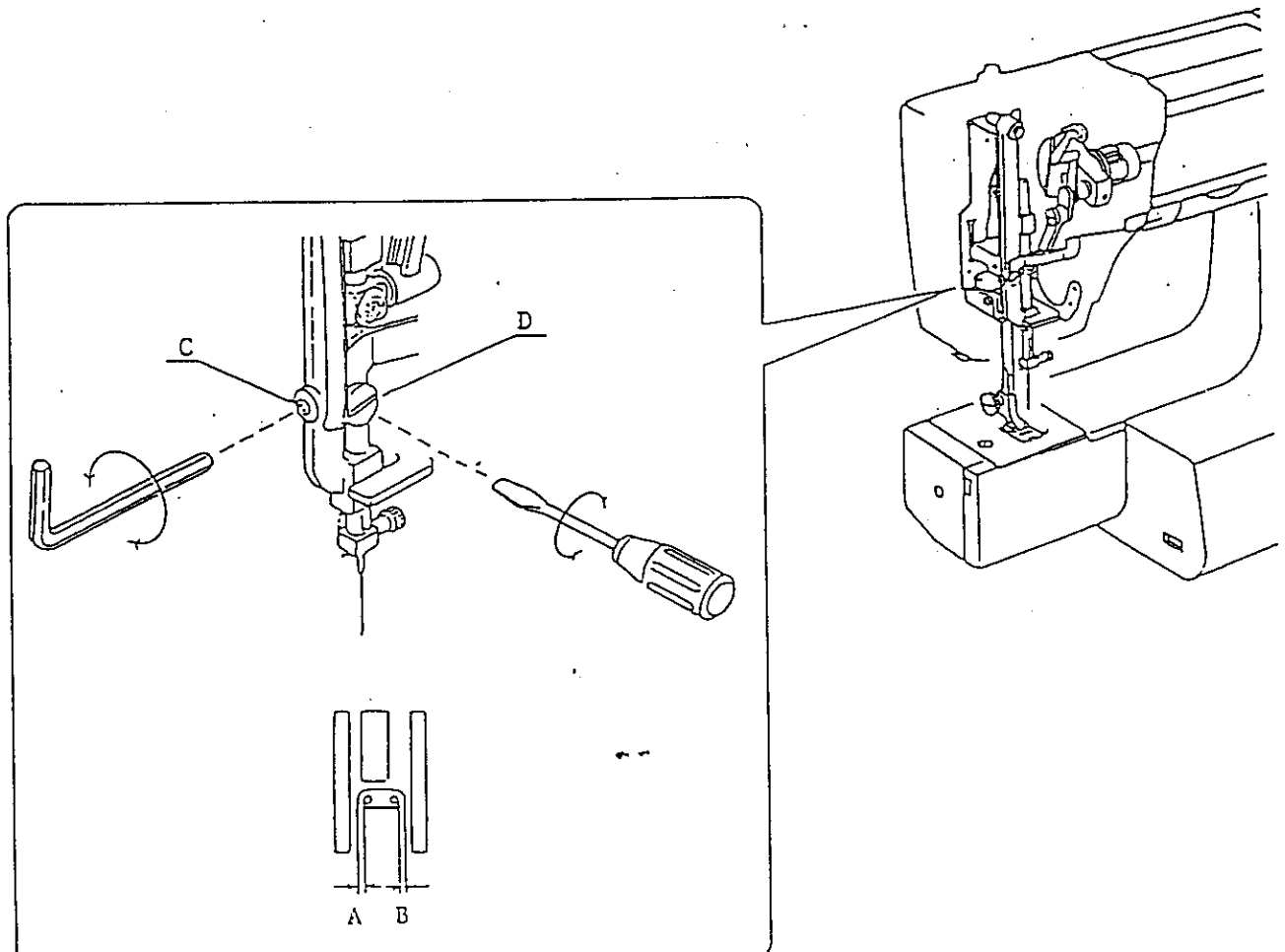

STRETCH STITCH BALANCE

MACHINE SETTING: 1. STITCH SELECTOR : [  ]  
STITCH LENGTH : [ S.S. ]

- ADJUSTMENT:
1. REMOVE THE ARM COVER PLATE.
  2. TURN THE STRETCH STITCH ADJUSTING SCREW (C) IN THE DIRECTION OF (D) WHEN THE REVERSE STITCH LENGTH (B) IS SHORTER THAN THE FORWARD STITCH LENGTH (A).  
TURN THE STRETCH STITCH ADJUSTING SCREW (C) IN THE DIRECTION OF (E) WHEN THE REVERSE STITCH LENGTH (B) IS LONGER THAN THE FORWARD STITCH LENGTH (A).
  3. ATTACH THE ARM COVER PLATE.

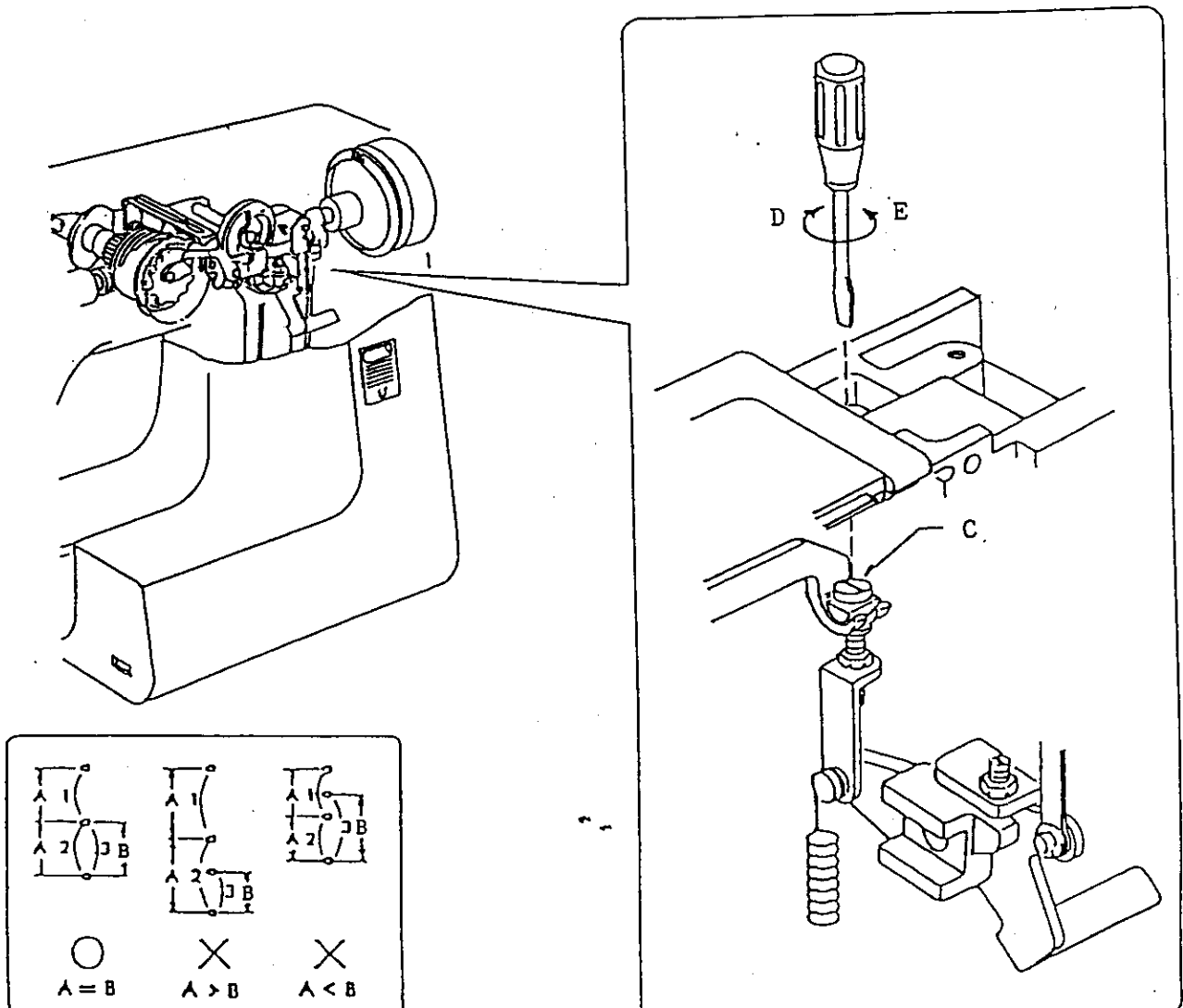

FEED DOG HEIGHT

MACHINE SETTING: 1. STITCH LENGTH : [ 4 ]  
2. NEEDLE BAR : AT ITS HIGHEST POSITION

CHECK:

1. RAISE THE PRESSER FOOT.
2. PLACE THE FEED DOG HEIGHT GAUGE #68367 (A) ON THE NEEDLE PLATE.
3. TURN THE HANDWHEEL TOWARD YOU BY HAND AND CHECK THE FEED DOG HEIGHT.
4. THE FEED DOG HEIGHT SHOULD BE AS PER THE FOLLOWING CHART.

ADJUSTMENT:

1. OPEN THE SHUTTLE COVER.
2. LOOSEN THE SCREW (B) AND TURN THE ECCENTRIC PIN (C) IN EITHER DIRECTION TO ADJUST THE FEED DOG HEIGHT AS REQUIRED.
3. TIGHTEN THE SCREW (B) SECURELY.

GAUGE		FEED DOG HEIGHT
FACE (A) 1.25 MM	FACE (B) (RED) 1.00 MM	
NOT MOVING	MOVING	CORRECT
NOT MOVING	NOT MOVING	LOW
MOVING	MOVING	HIGH

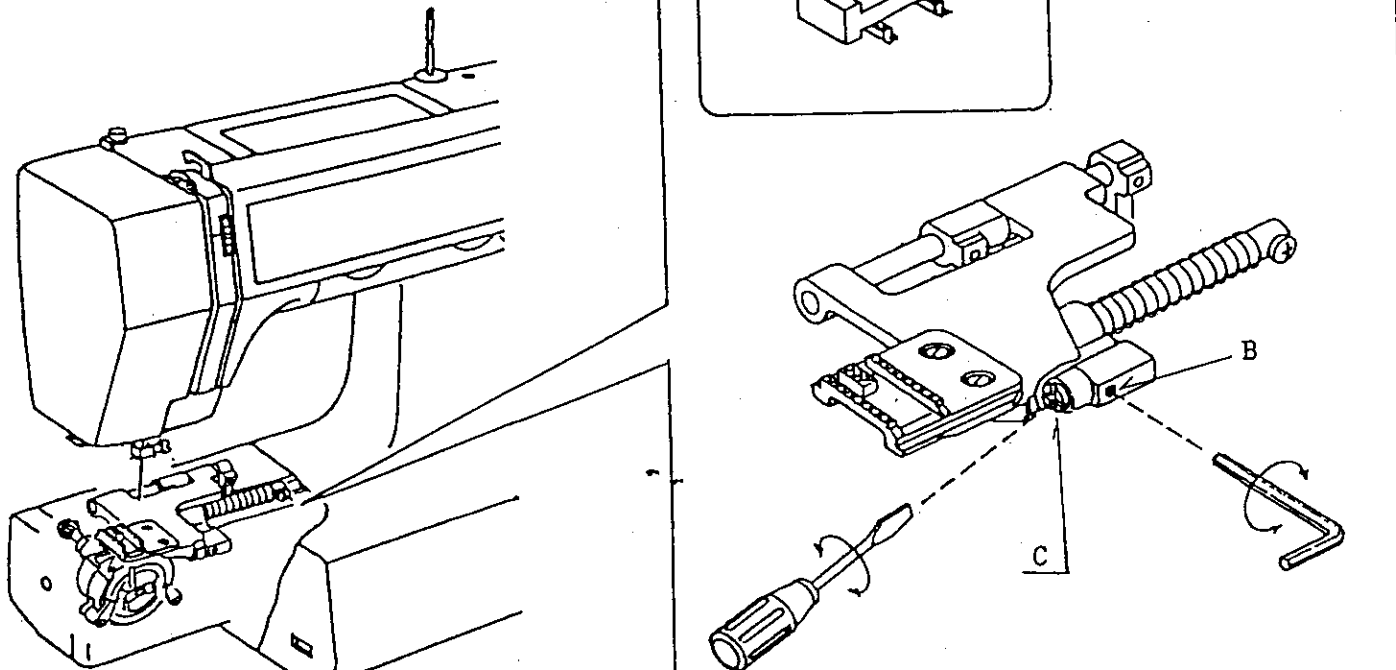

NEEDLE CLEARANCE TO SHUTTLE

MACHINE SETTING: 1. STITCH SELECTOR : [  ]

CHECK:

1. REPLACE THE NEEDLE WITH THE TESTPIN #68368.
2. THE CLEARANCE BETWEEN THE TESTPIN #68368 (A) AND SHUTTLE HOOK (B) SHOULD BE 0 ~ +0.15 MM.

ADJUSTMENT:

1. REMOVE THE EXTENSION TABLE AND OPEN THE SHUTTLE RACE COVER.
2. LOOSEN THE SET SCREW (C) ON LOWER FRONT SHAFT BUSHING (D) AND SLIDE THE SHAFT ABOUT 0.5 MM TO THE RIGHT TO MAKE A SLACK BETWEEN GEARS. THEN, TIGHTEN THE SCREW (C) TEMPORARILY.
3. LOOSEN THE TWO SHUTTLE RACE SET SCREWS (E).
4. MOVE THE SHUTTLE RACE UNIT AXIALLY EITHER FORWARD OR BACKWARD TO ADJUST THE CLEARANCE BETWEEN THE TESTPIN #68368 (A) AND THE SHUTTLE HOOK (B) AT 0 ~ +0.15 MM TIGHTEN ONE OF THE SET SCREWS (E) TEMPORARILY.
5. SET THE STITCH SELECTOR AT MAXIMUM ZIGZAG WIDTH. TURN THE HAND WHEEL TO CHECK IF THE CLEARANCE BETWEEN THE TESTPIN #68368 (A) AND INNER EDGES OF THE SHUTTLE RACE SPRING (F) AT THE LEFT AND RIGHT NEEDLE DROPS ARE EQUAL. IF NOT, MAKE AND ADJUSTMENT BY TURNING THE SHUTTLE RACE UNIT.
6. TIGHTEN THE TWO SHUTTLE RACE SET SCREWS (E).
7. LOOSEN THE SET SCREW (C) ON LOWER SHAFT FRONT BUSHING (D) AND SLIDE THE SHAFT BACK TO THE ORIGINAL POSITION WHILE ADJUSTING THE BACKLASH. TIGHTEN THE SCREW (C) FIRMLY.
8. CLOSE THE SHUTTLE RACE COVER AND ATTACH THE EXTENSION TABLE.

(NOTE) \* THE BACKLASH PLAY SHOULD BE LESS THAN 0.3 MM AND LOWER SHAFT TURNS SMOOTHLY.

\* AFTER THE ADJUSTMENT, CHECK THE NEEDLE TIMING TO THE SHUTTLE IN PAGE 15.

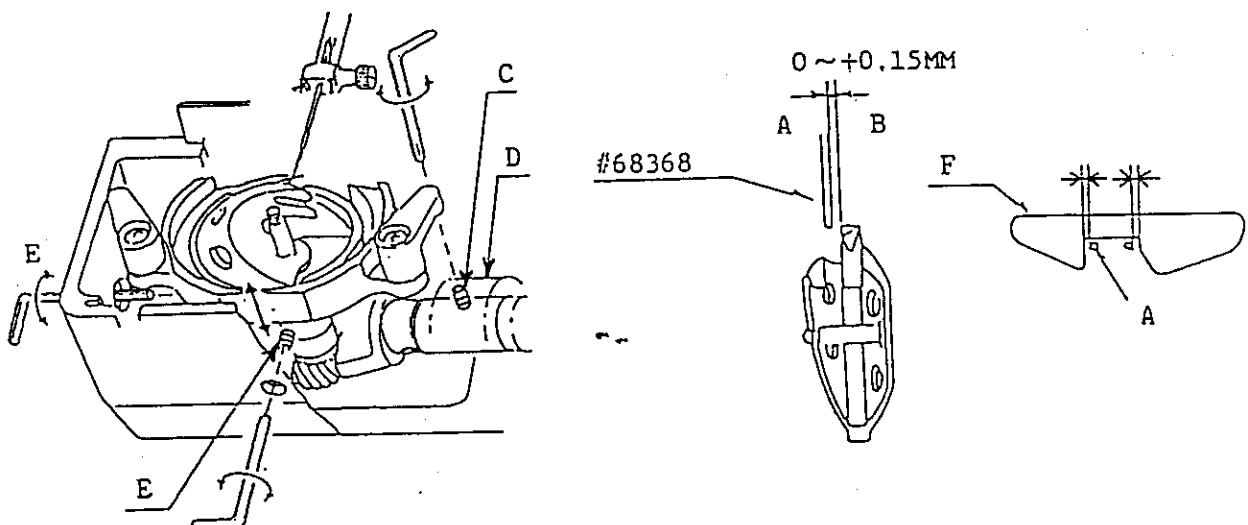

NEEDLE BAR HEIGHT

MACHINE SETTING: 1. STITCH SELECTOR : [  ]

- CHECK:
1. OPEN THE SHUTTLE COVER.
  2. REPLACE THE NEEDLE WITH THE TESTPIN #68368 (A).
  3. REMOVE THE SHUTTLE HOOK AND INSERT THE RADIAL TIMING GAUGE #68366 (B) ONTO THE SHUTTLE DRIVER.
  4. TURN THE HAND WHEEL TOWARD YOU BY HAND UNTIL THE NEEDLE BAR REACHES ITS LOWEST POSITION.
  5. THE TIP OF THE TESTPIN #68368 (A) SHOULD BE IN BETWEEN THE TWO HORIZONTAL LINES ENGRAVED ON THE RADIAL TIMING GAUGE #68366 (B).

- ADJUSTMENT:
1. LOOSEN THE SCREW (C) OF THE NEEDLE BAR HOLDER (D).
  2. MOVE THE NEEDLE BAR (E) UP OR DOWN BY HAND UNTIL THE TIP OF THE TESTPIN #68368 (A) COMES IN BETWEEN THE TWO HORIZONTAL PARALLEL LINES ENGRAVED ON THE RADIAL TIMING GAUGE #68366 (B).

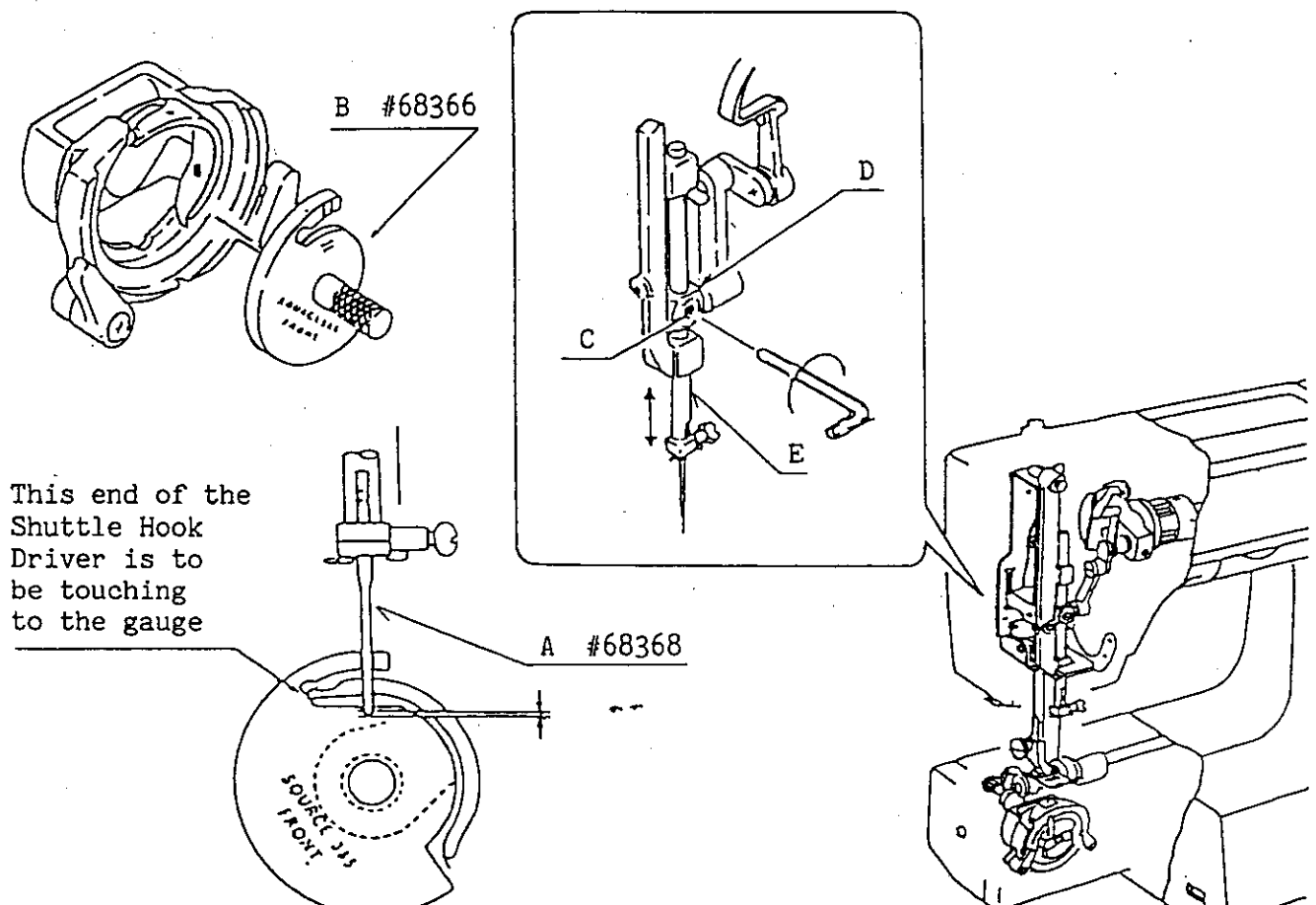



NEEDLE TIMING TO SHUTTLE

MACHINE SETTING: 1. STITCH SELECTOR : [  ]

CHECK:

1. OPEN THE SHUTTLE COVER.
2. REPLACE THE NEEDLE WITH THE TESTPIN #68368 (A).
3. REMOVE THE SHUTTLE HOOK AND INSERT THE RADIAL TIMING GAUGE #68366 (B) ONTO THE SHUTTLE DRIVER.
4. TURN THE HANDWHEEL TOWARD YOU BY HAND UNTIL THE NEEDLE BAR REACHES ITS LOWEST POSITION.
5. THE TIP OF THE TESTPIN #68368 (A) SHOULD BE IN BETWEEN THE TWO VERTICAL LINES ENGRAVED ON THE RADIAL TIMING GAUGE #68366 (B).

ADJUSTMENT:

1. REMOVE THE ARM COVER, THE BELT COVER AND THE CONTROL PANEL UNIT.
2. LOOSEN THE SCREWS (C) AND (D).
3. ROTATE THE SHUTTLE DRIVER UNTIL THE TIP OF THE TESTPIN #68368 (A) COMES IN BETWEEN THE TWO VERTICAL LINES ENGRAVED ON THE RADIAL TIMING GAUGE #68366 (B).
4. TIGHTEN THE SCREWS (C) AND (D) SECURELY.
5. ATTACH THE CONTROL PANEL UNIT, THE BELT COVER AND THE ARM COVER.

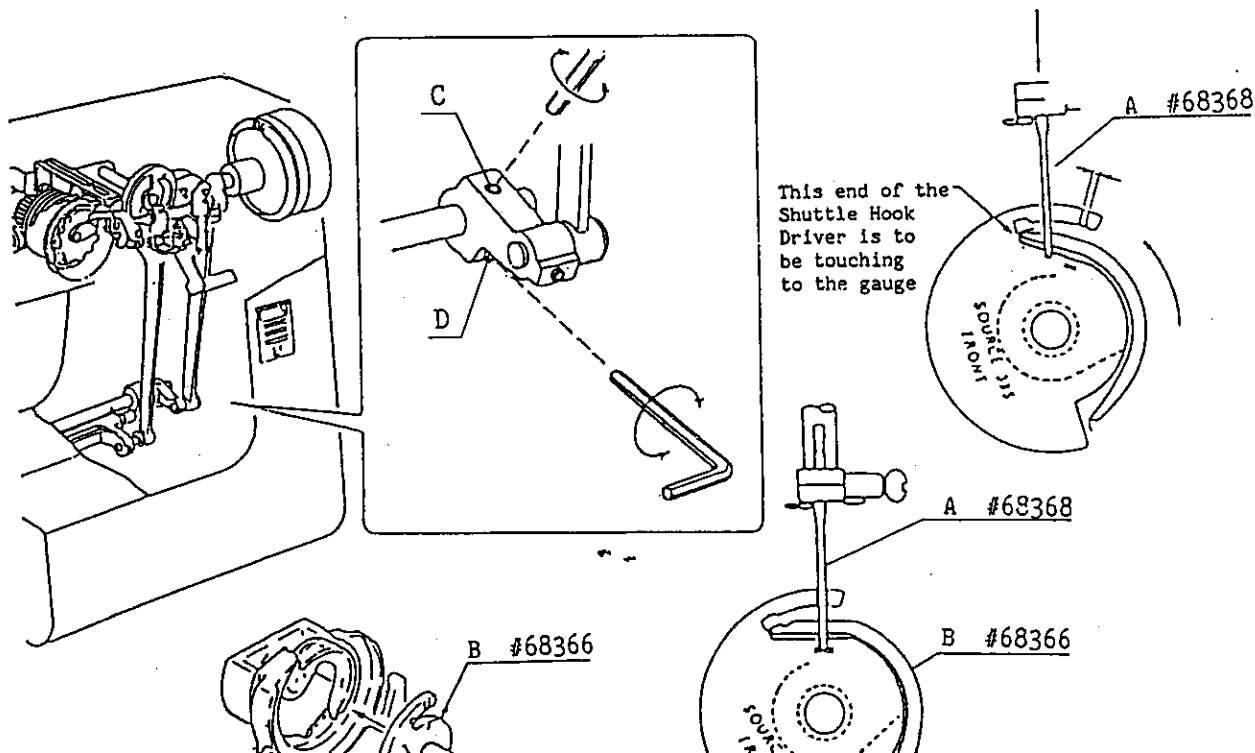

ZERO FEEDING

MACHINE SETTING: 1. STITCH SELECTOR :   
STITCH LENGTH : 4

CHECK: 1. PUT A PIECE OF PAPER ON THE NEEDLE PLATE.  
2. IF THE PAPER MOVES WHEN YOU TURN THE HANDWHEEL TOWARD YOU, MAKE ADJUSTMENT AS FOLLOWS.

ADJUSTMENT: 1. REMOVE THE ARM COVER, THE BELT COVER AND THE CONTROL PANEL UNIT.  
2. PUT A PIECE OF PAPER ON THE NEEDLE PLATE.  
3. TURN THE ADJUSTING SCREW (C) IN THE DIRECTION OF (A) WHEN THE PAPER MOVES FORWARD.  
TURN THE ADJUSTING SCREW (C) IN THE DIRECTION OF (B) WHEN THE PAPER MOVES BACKWARD.  
4. ATTACH THE CONTROL PANEL UNIT, THE BELT COVER AND THE ARM COVER.

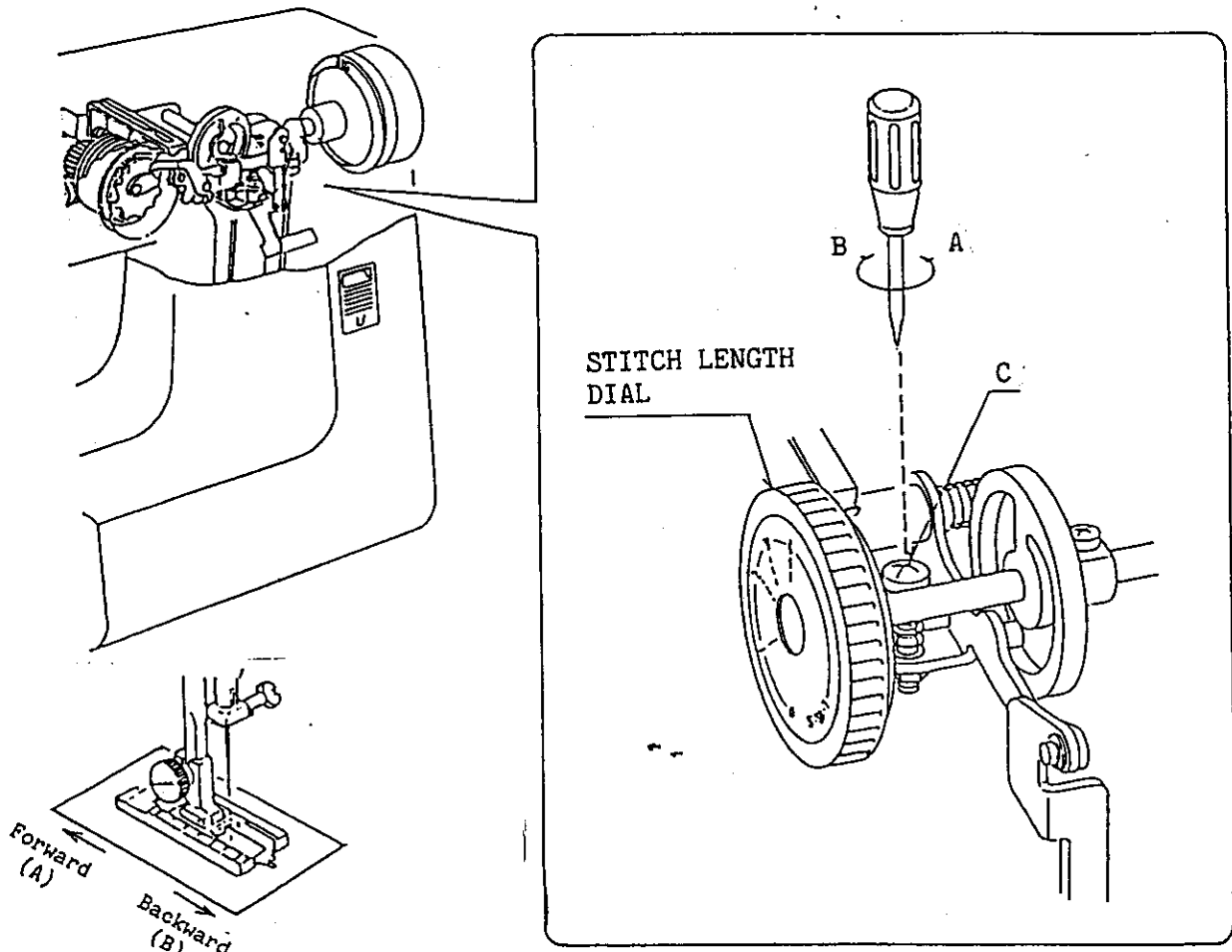

AUTOMATIC MECHANISM

MACHINE SETTING: 1. STITCH SELECTOR :  $\boxed{1} \rightarrow \boxed{\begin{smallmatrix} 4 \\ 2 \end{smallmatrix}} \rightarrow \boxed{3} \rightarrow \boxed{\begin{smallmatrix} 4 \\ 2 \end{smallmatrix}}$   
STITCH LENGTH : BLUE ZONE

CHECK:

1. ATTACH THE SLIDING BUTTONHOLE FOOT.
2. WHEN SEWING BUTTONHOLE, STITCHES ON EACH SIDE OF BUTTONHOLES SHOULD BE THE SAME STITCH DENSITY.  
THE VARIANCE OF 9 TO 11 STITCHES IN THE RIGHT-SIDE ROW AGAINST 10 STITCHES IN THE LEFT-SIDE ROW IS CONSIDERED ACCEPTABLE FEED BALANCE FOR BUTTONHOLE SEWING.

ADJUSTMENT:

1. REMOVE THE TOP COVER, THE BELT COVER AND THE CONTROL PANEL UNIT.
2. TURN THE ADJUSTING SCREW (C) IN THE DIRECTION OF (B) WHEN THE RIGHT SIDE ROW OF BUTTONHOLE IS COARSE, AS IN FIG. (D).  
TURN THE ADJUSTING SCREW (C) IN THE DIRECTION OF (A) WHEN THE LEFT SIDE ROW OF BUTTONHOLE IS COARSE, AS IN FIG. (E).
3. ATTACH THE CONTROL PANEL UNIT, THE BELT COVER AND THE TOP COVER.

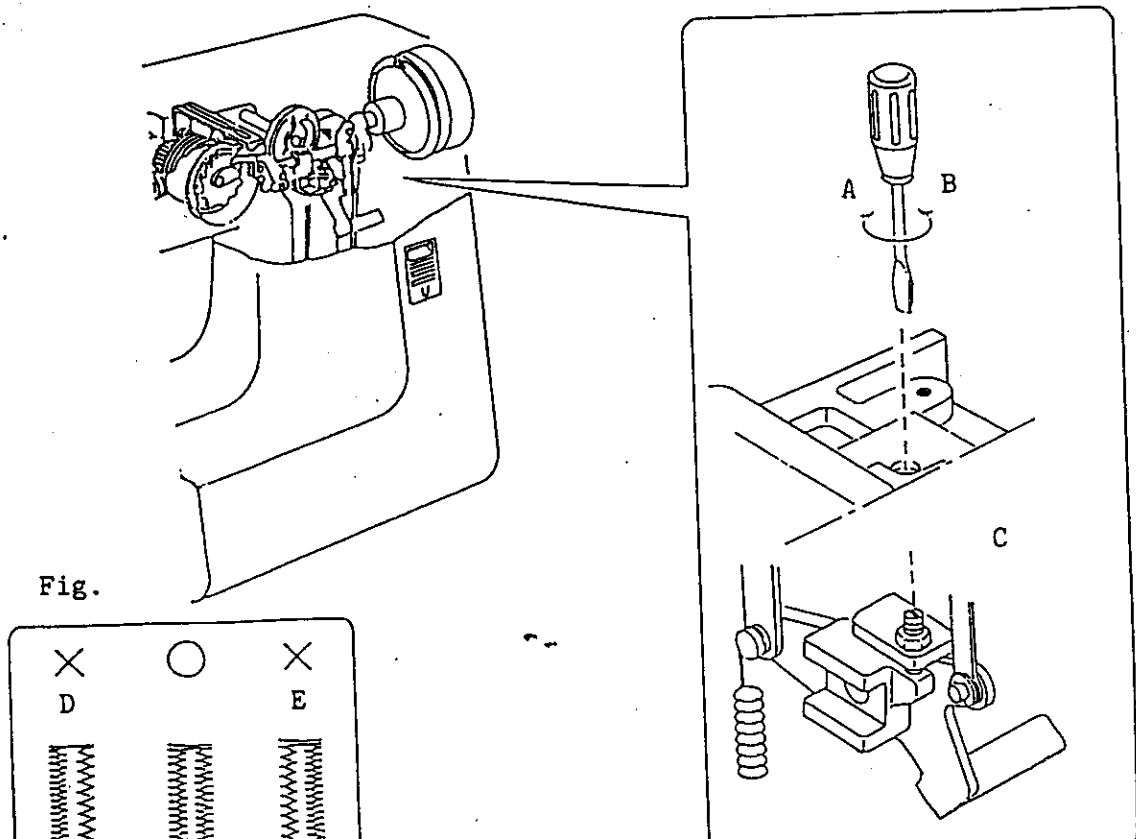

DISENGAGEMENT OF CAM FOLLOWER

MACHINE SETTING: 1. STITCH SELECTOR : [  $\downarrow$  ]

CHECK: 1. IN CASE THE NEEDLE BAR MAKES ZIGZAG MOVEMENT AT [  $\downarrow$  ], OR THE STITCH SELECTOR DOES NOT TURN OR DOES NOT MAKE A SMOOTH TURN, MAKE ADJUSTMENTS AS FOLLOWS:

- ADJUSTMENT:
1. REMOVE THE ARM COVER PLATE, THE BELT COVER AND THE CONTROL PANEL UNIT.
  2. TURN THE HAND WHEEL TOWARD YOU BY HAND UNTIL THE CAM FOLLOWER (A) COMES UP TO THE TOP OF THE BASIC ZIGZAG CAM (B) AS SHOWN.
  3. LOOSEN THE SCREW (C) AND PUSH THE CONVEX PART OF THE CAM FOLLOWER LEVER (D) IN THE DIRECTION OF  $\leftarrow \rightarrow$  UNTIL THE LEVER TOUCHES THE STITCH SELECTOR CAM.
  4. TIGHTEN THE SCREW (C).
  5. ATTACH THE CONTROL PANEL UNIT, THE BELT COVER AND THE ARM COVER PLATE.

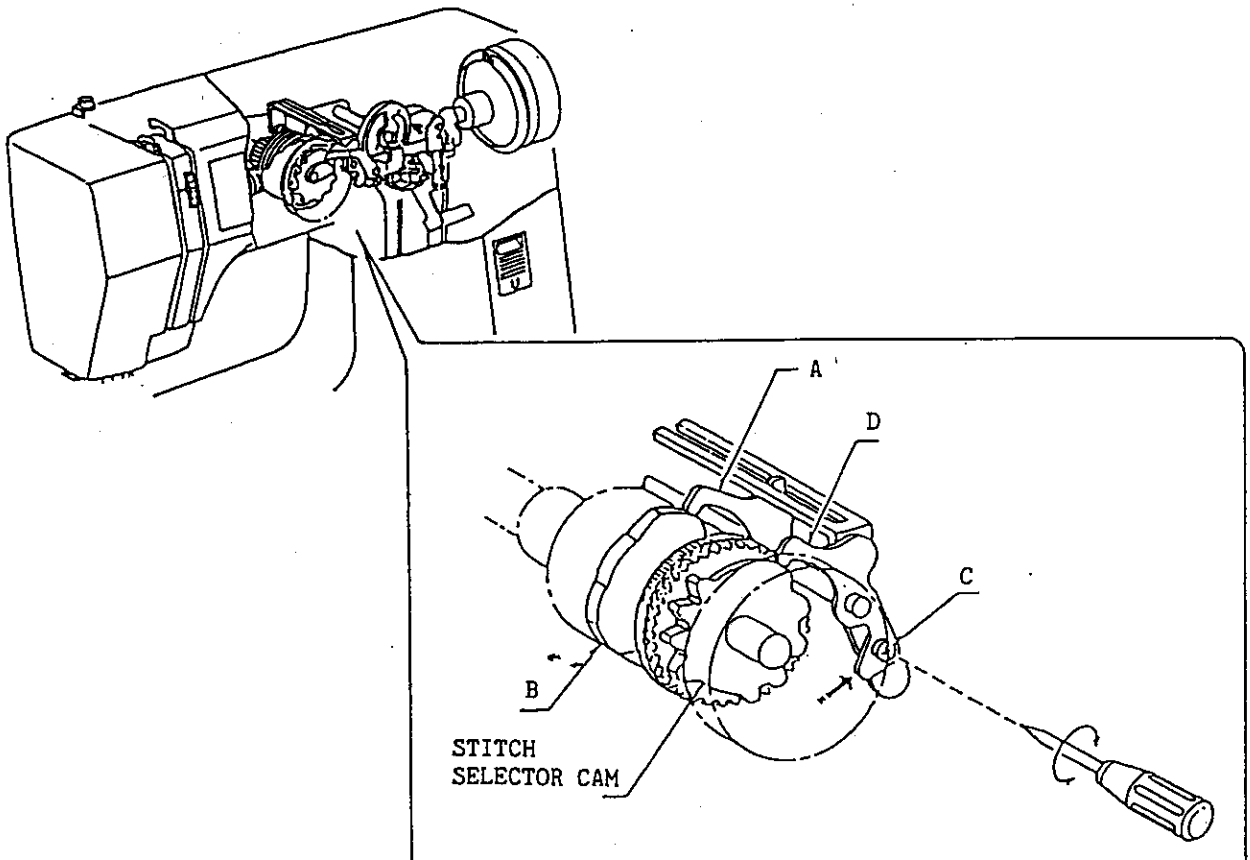

MOTOR BELT TENSION

CHECK:

1. TOO TIGHT OR TOO LOOSE MOTOR BELT TENSION MAY CREATE BELT NOISE AND ALSO TOO TIGHT MOTOR BELT TENSION CAN CAUSE THE MACHINE TO RUN SLOW AND WILL OVERLOAD THE MOTOR.  
TOO LOOSE MOTOR BELT TENSION MAY CAUSE JUMPING OF THE BELT TEETH ON THE MOTOR PULLEY.
2. THE CORRECT MOTOR BELT TENSION IS THAT THE DEFLECTION OF MOTOR BELT IS ABOUT 7 MM (0.28") - 9 MM (0.36") WHEN PUSHING THE MOTOR BELT BY FINGER AT ABOUT 300 GRAMS LOAD.

ADJUSTMENT:

1. REMOVE THE BELT COVER.
2. LOOSEN THE SCREWS (A) AND (B).
3. MOVE THE MOTOR UP OR DOWN TO ADJUST THE DEFLECTION ABOUT 7 MM (0.28") - 9 MM (0.36").
4. TIGHTEN THE SCREWS (A) AND (B).

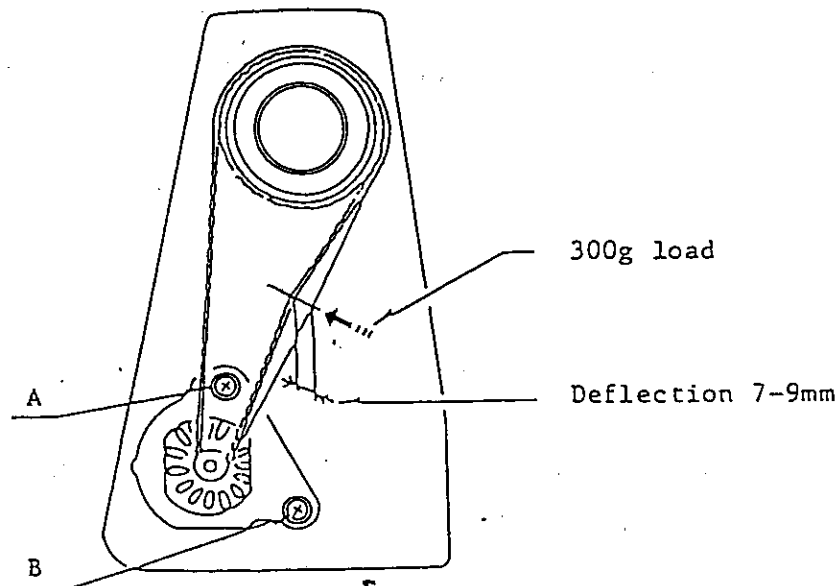

WIRING

1. WIRING FOR MOTOR ATTACHMENT CAP ASSEMBLY

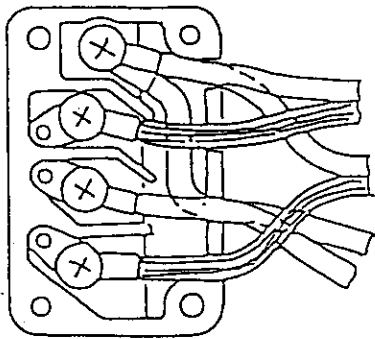

M  
L  
P

M : Motor  
L : Lamp  
P : Power Switch

2. WIRING DIAGRAM

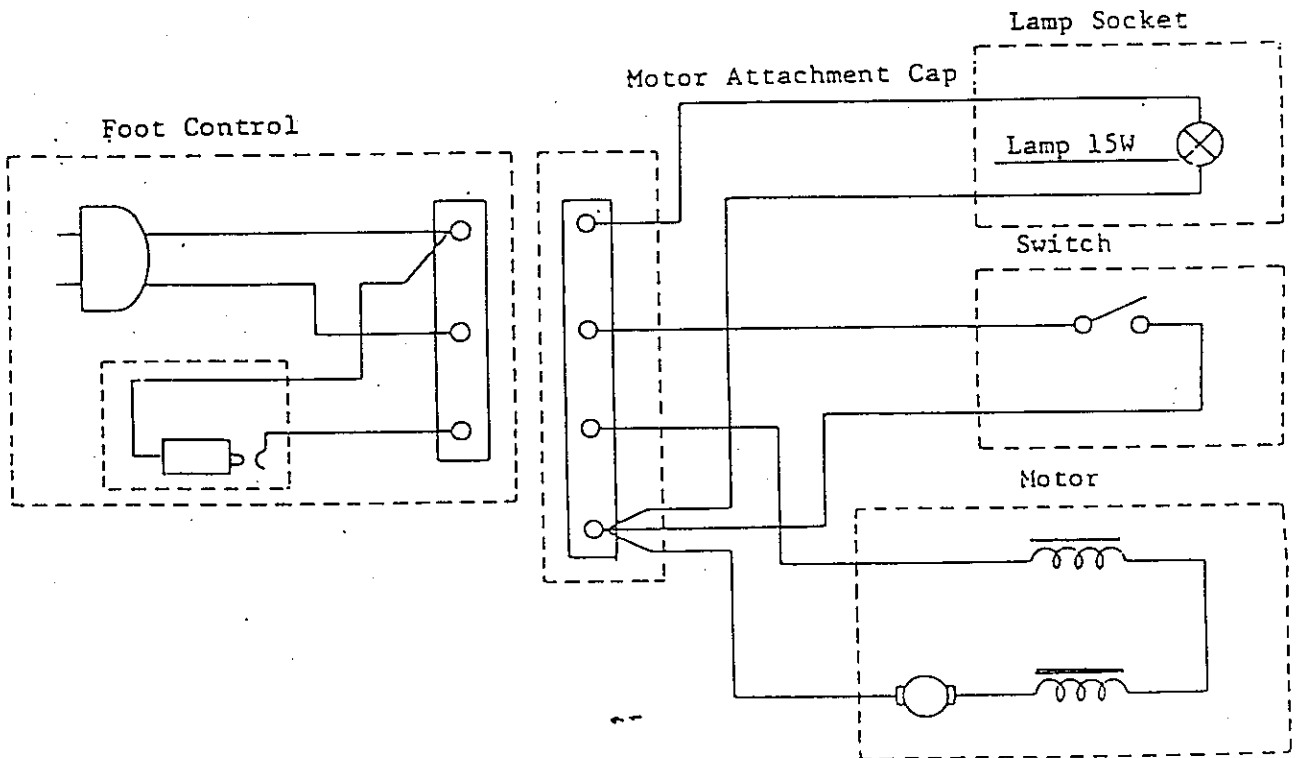

OILING

FACTORY LUBRICATED PARTS WILL PROVIDE YEARS OF HOUSEHOLD SEWING WITHOUT ROUTINE OILING, BUT CHECK FOR POSSIBLE LUBRICATION NEEDS WHENEVER SERVICING MACHINES.

OIL: USE GOOD QUALITY SEWING MACHINE OIL AT THE POINTS (A, B, C, D, E, F & G) INDICATED BY BLACK ARROWS.

GREASE: THE WHITE GREASE IS RECOMMENDED FOR USE ON ALL MODEL SEWING MACHINES. IT IS AN IMPROVED GREASE AND CAN BE USED ON METAL AND PLASTIC WHICH POINTS ARE INDICATED BY WHITE ARROWS (H, I & J).



HOW TO ORDER

<u>PARTS NO.</u>	<u>DESCRIPTION</u>	<u>PRICE</u>
	SEWING MACHINE OIL	
EM/40M	WHITE GREASE	

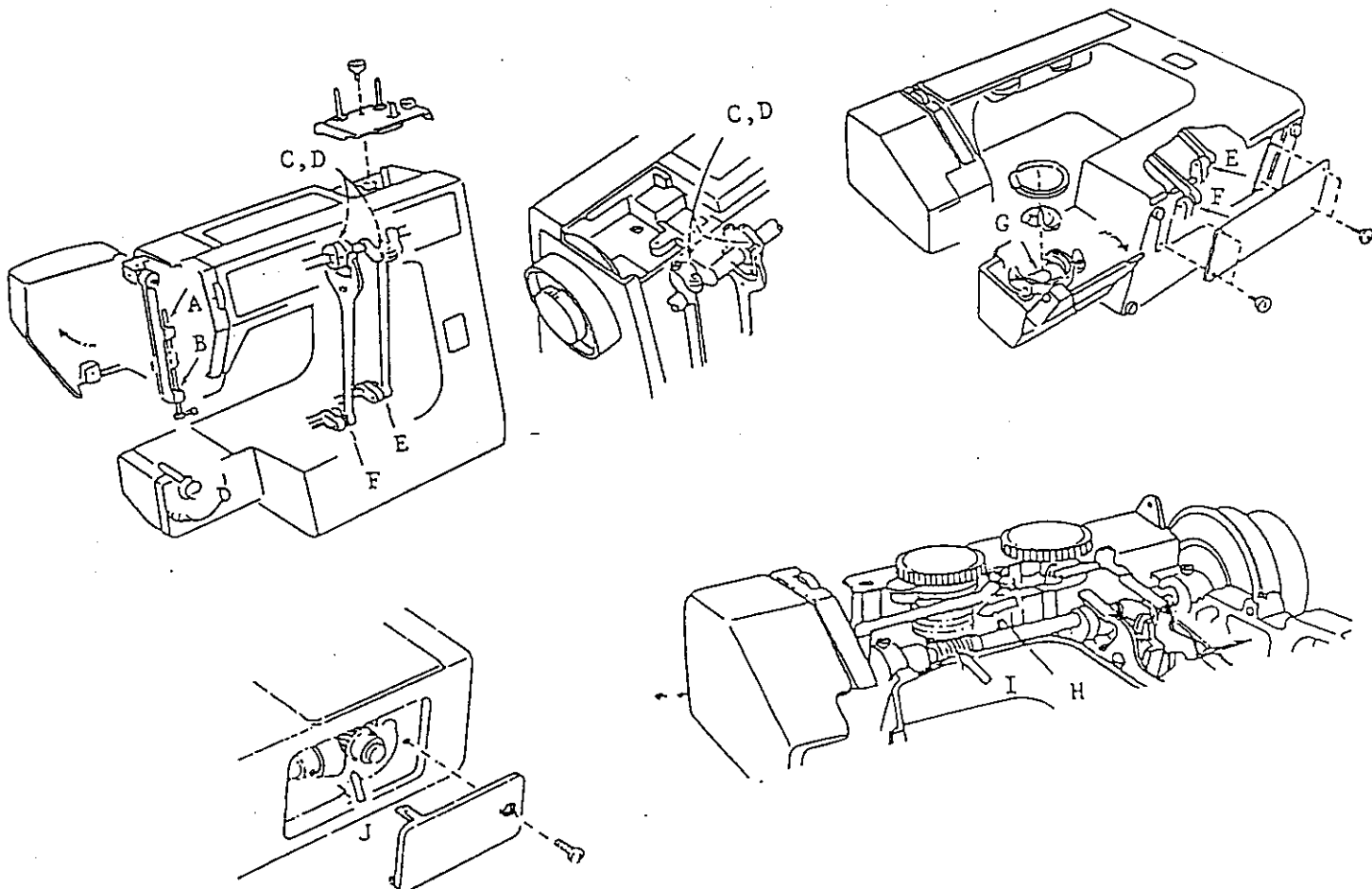
ORDER THROUGH YOUR PRDC IN THE USUAL MANNER; DIVISION 20, SOURCE 158.

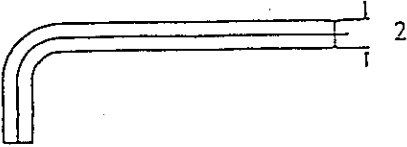
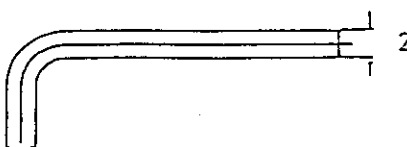
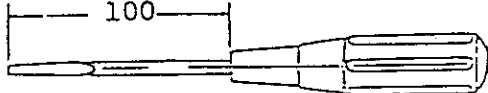
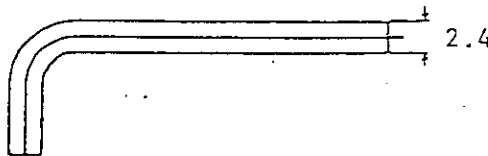
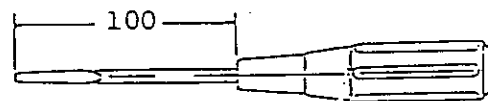
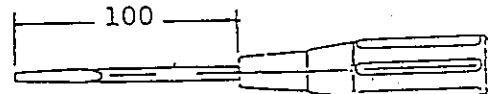
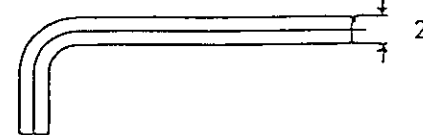

SPECIAL TOOLS REQUIRED

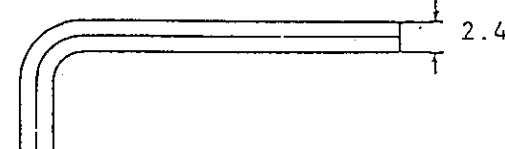
NO.	ADJUSTMENT	NECESSARY TOOLS	
1	PRESSER BAR HEIGHT AND ALIGNMENT	Allen Key (Hexagon bar spanner 2mm)	
2	ZIAZAG SYNCHRONIZATION	Allen Key (Hexagon bar spanner 2mm)	
3	STITCH WIDTH ADJUSTMENT	Screw Driver (100mm)  Allen Key (Hexagon bar spanner 2.4mm)	 
4	STRETCH STITCH BALANCE	Screw Driver (100mm)	
5	FEED DOG HEIGHT	Screw Driver (100mm)  Allen Key (Hexagon bar spanner 2mm)  Feed Dog Height Gauge (Source 385)	  
6	NEEDLE CLEARANCE TO SHUTTLE	Test Pin  Allen Key (Hexagon bar spanner 2.4mm)	 

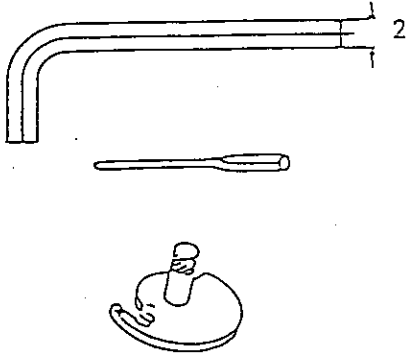
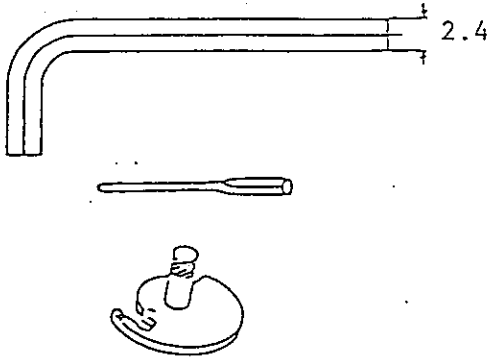
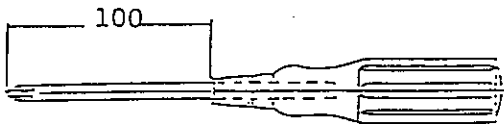
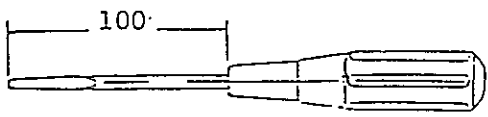
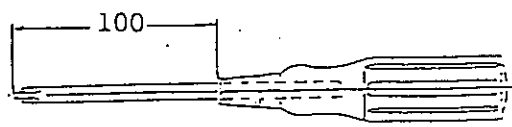

SPECIAL TOOLS REQUIRED

NO.	ADJUSTMENT	NECESSARY TOOLS	
7	NEEDLE BAR HEIGHT	Allen Key (Hexagon bar spanner 2mm)  Test Pin  Radial Timing Gauge (Source 385)	
8	NEEDLE TIMING TO SHUTTLE	Allen Key (Hexagon bar spanner 2.4mm)  Test Pin  Radial Timing Gauge (Source 385)	
9	ZERO FEEDING	Plus Driver (100mm)	
10	AUTOMATIC MECHANISM	Screw Driver (100mm)	
11	DISENGAGEMENT OF CAM FOLLOWER	Plus Driver (100mm)	

STITCH SELECTOR/STITCH LENGTH CONTROLS

STITCH SELECTOR/STITCH LENGTH

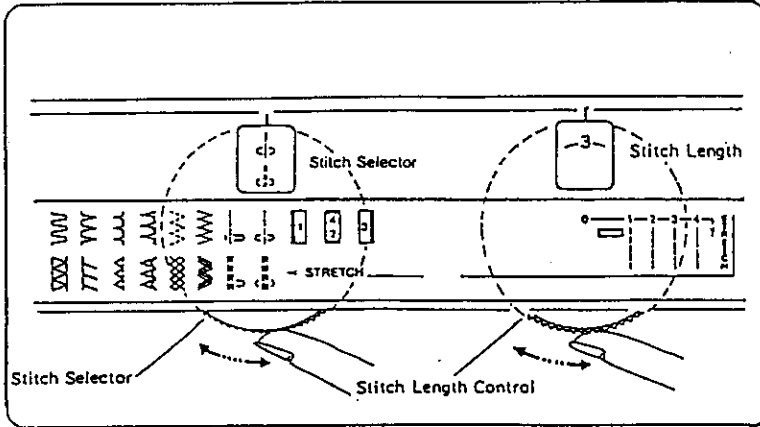

Model 12708

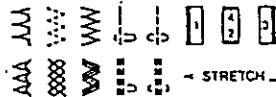

Model 12710

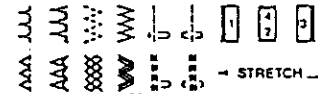

Model 12712

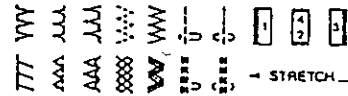

STITCH LENGTH

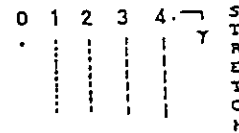

STRETCH STITCH

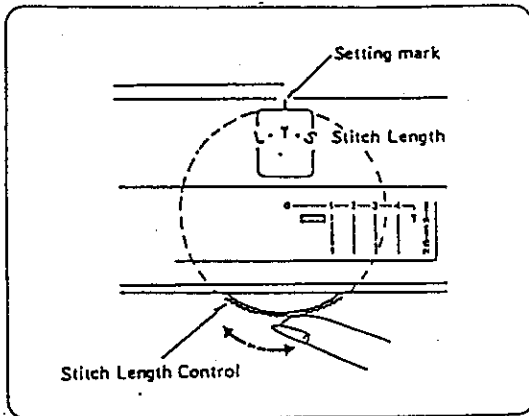

TO SELECT STRETCH STITCHES, SET THIS CONTROL AT ▼ POSITION.

BUTTON HOLES

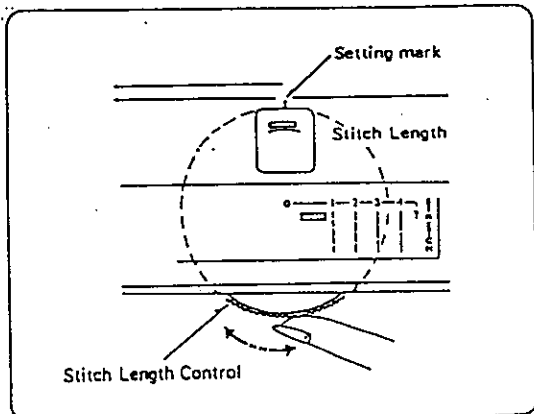

PLEASE REFER TO PAGE 17 FOR THE ADJUSTMENT OF STITCH DENSITY IN BUTTONHOLES.

STITCH SELECTOR

MODEL 11602 ONLY

STITCH SELECTOR

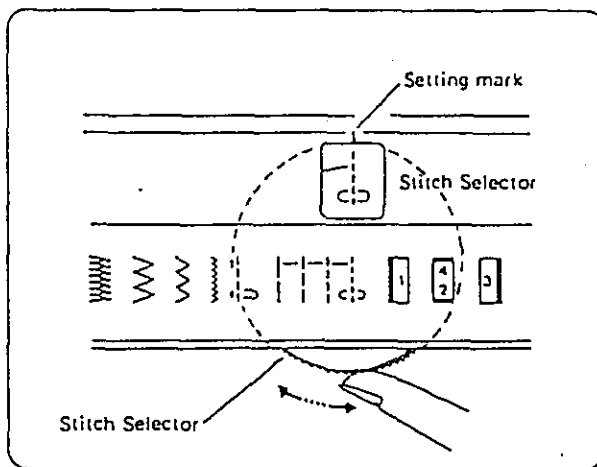

STITCHES

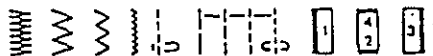

## Free Manuals Download Website

<http://myh66.com>

<http://usermanuals.us>

<http://www.somanuals.com>

<http://www.4manuals.cc>

<http://www.manual-lib.com>

<http://www.404manual.com>

<http://www.luxmanual.com>

<http://aubethermostatmanual.com>

Golf course search by state

<http://golfingnear.com>

Email search by domain

<http://emailbydomain.com>

Auto manuals search

<http://auto.somanuals.com>

TV manuals search

<http://tv.somanuals.com>