



KENWOOD
HI/FI STEREO COMPONENTS

SERVICE MANUAL

KD-600
(KD-650)

NOTE: KD-600 is not provided with tonearm, shell and cartridge.

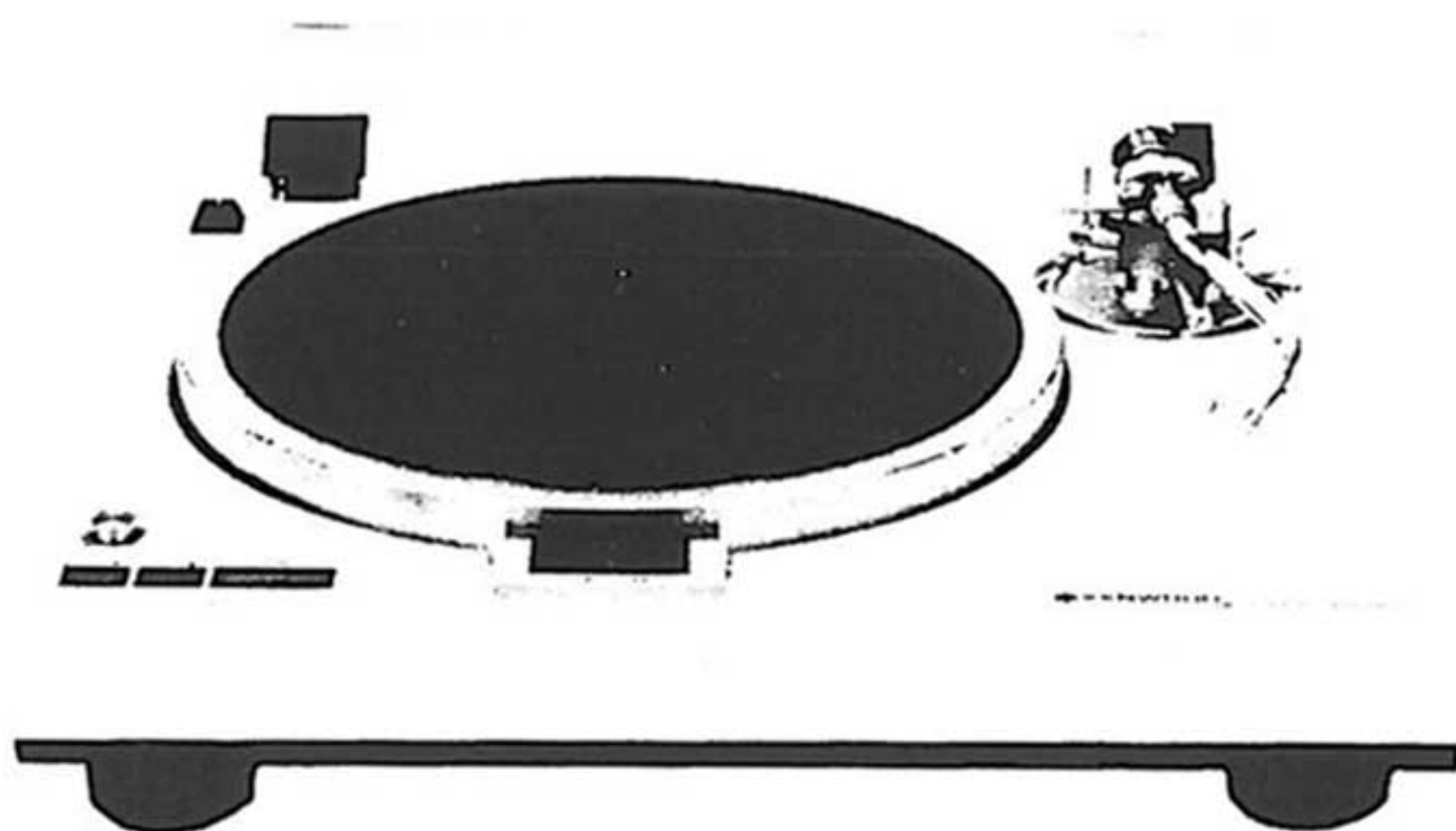

(KD-650)

QUARTZ PLL DIRECT DRIVE TURNTABLE

CONTENTS

EXTERNAL VIEW.....	3
INTERNAL VIEW.....	4
CIRCUIT DESCRIPTION.....	5
BLOCK DIAGRAM.....	19
MECHANISM.....	20
DISASSEMBLY FOR REPAIR.....	20
ADJUSTMENT.....	22
EXPLODED VIEW.....	24
EXPLODED VIEW PARTS LIST.....	25
PARTS LIST.....	26
DESTINATIONS' PARTS LIST.....	27
PACKING.....	28
REVISED CIRCUIT.....	29
PC BOARD.....	29
SCHEMATIC DIAGRAM.....	31
WAVEFORM OF CHECK POINTS.....	32

Note:

Component and circuitry are subject to modification to insure best operation under differing local conditions. This manual is based on, the U.S. (K) standard, and provides information on regional circuit modification through use of alternate schematic diagrams, and information on regional component variations through use of parts list.

Region	Code
U.S.A.	K
Canada.....	P
PX.....	U
Australia.....	X
Europe.....	W
Scandinavia.....	L
England.....	T
South Africa.....	S
Other Areas.....	M
Audio Club.....	H

EXTERNAL VIEW

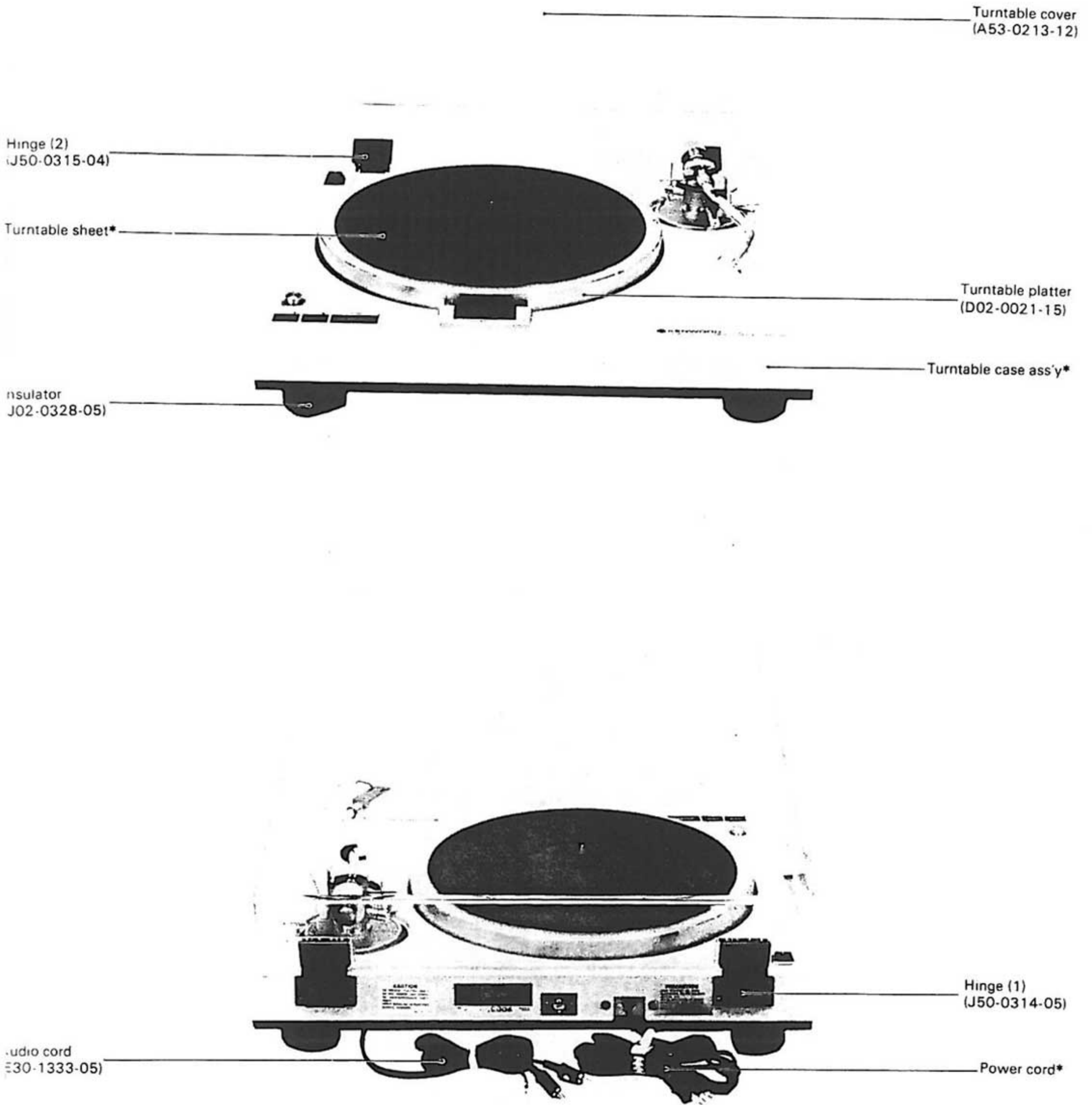

*Refer to Destinations' Parts List.

INTERNAL VIEW

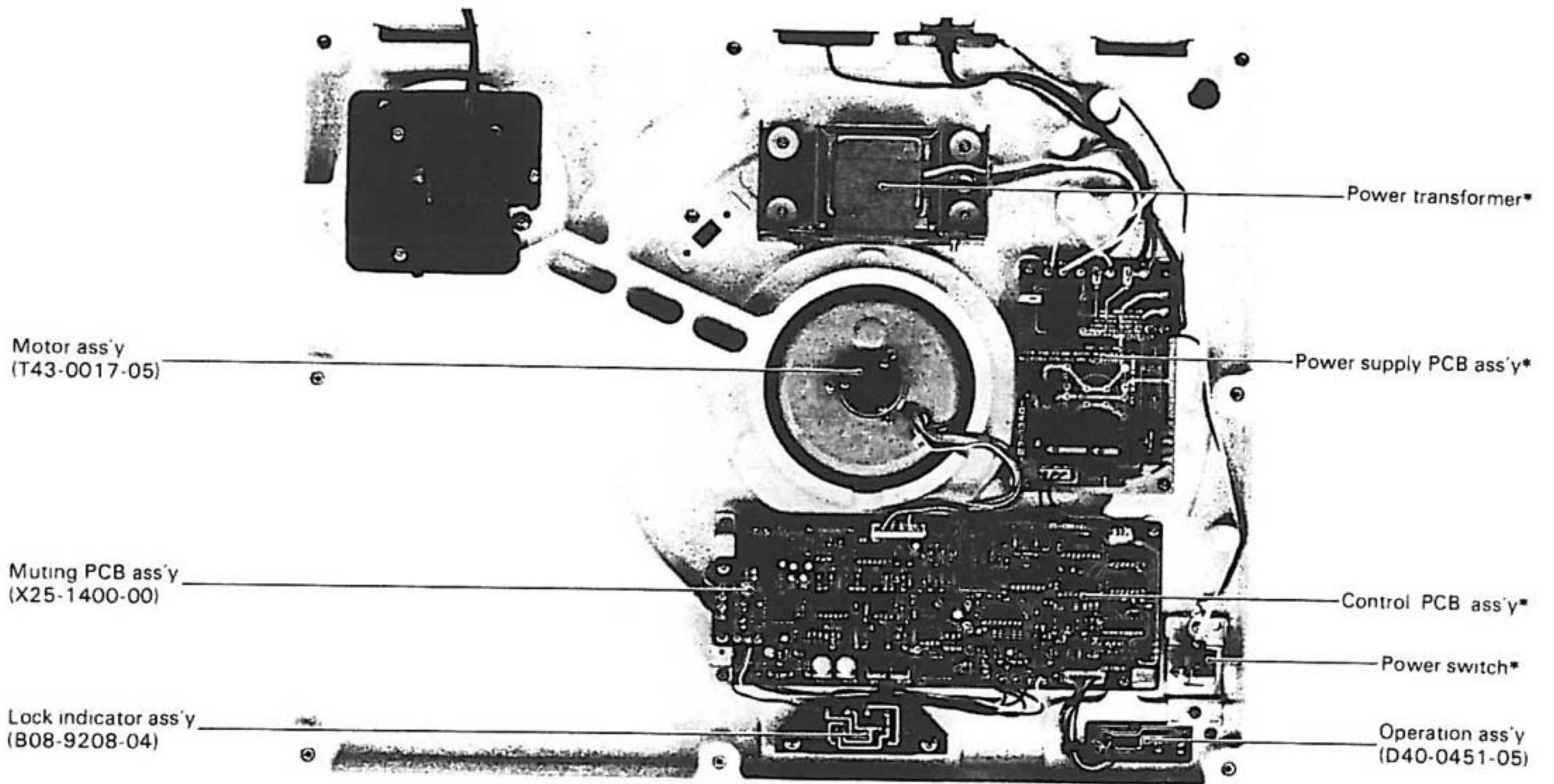
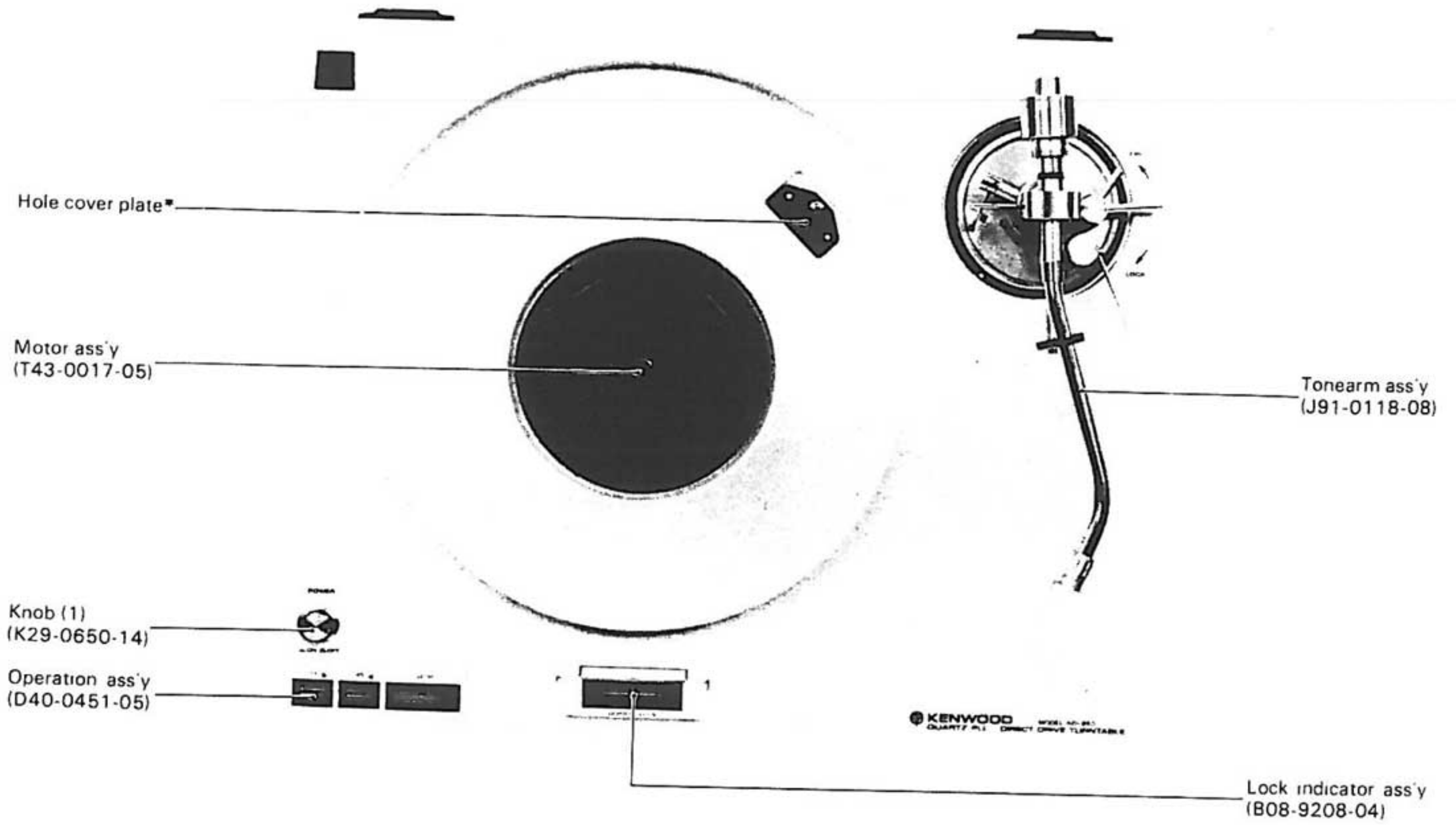

*Refer to Destinations' Parts List

CIRCUIT DESCRIPTION

FUNDAMENTAL THEORY OF QUARTZ PLL-TURNTABLE

As the motor structure of the KD-600 (650) is almost identical to that of the KD-750, we will omit the description of the motor operation of the KD-600 (650) in this manual

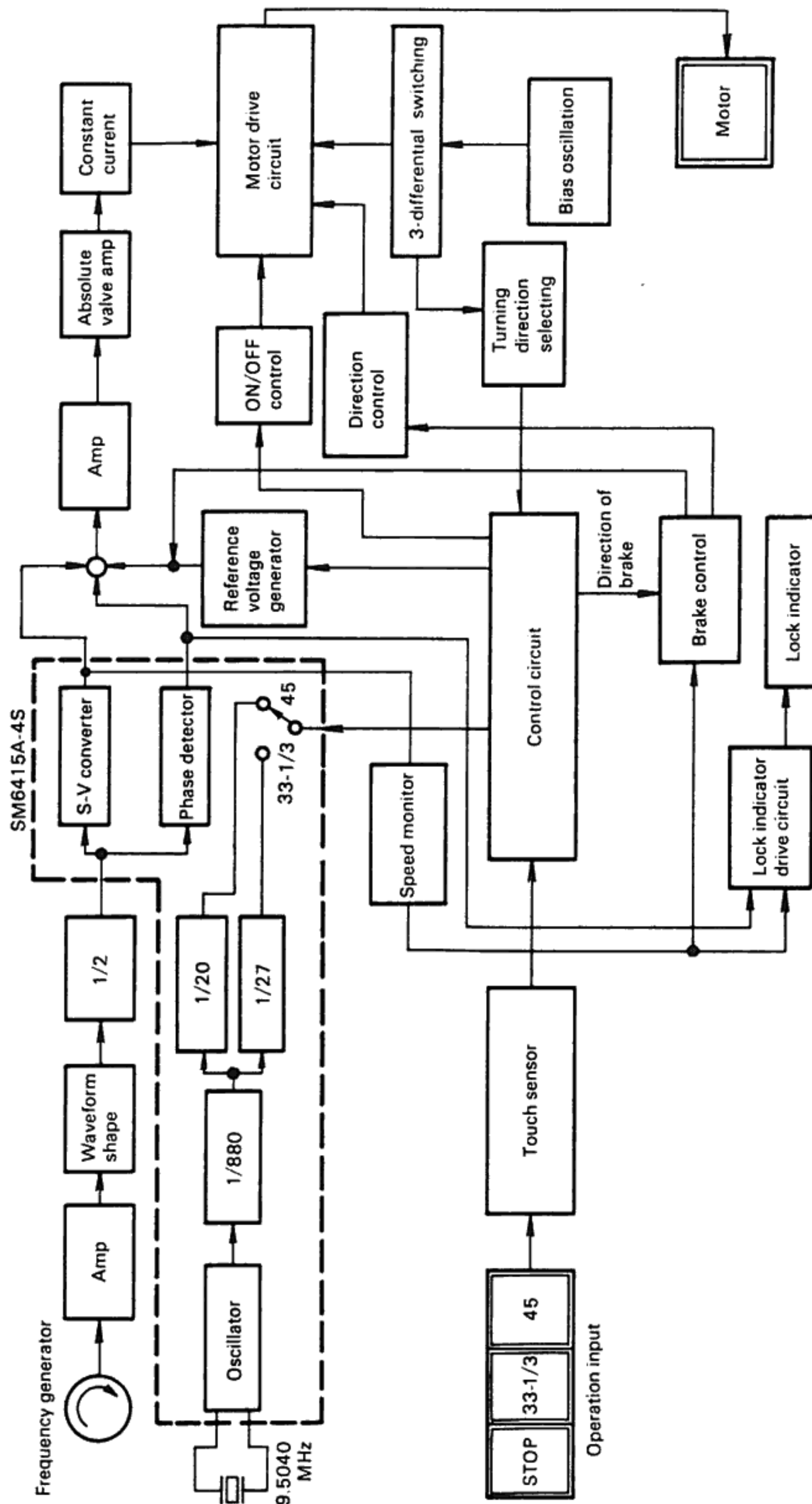

KD-600 (650) Speed Control Block Diagram

Instead, we will provide in this manual some detailed descriptions of the KD-600 (650)'s control circuit which was

not covered in detail in the manual for the KD-750

CIRCUIT DESCRIPTION

NEGATIVE FEEDBACK THEORY

The following figure shows a negative feedback circuit constituting a closed-loop system. Where M is a control object, β is a feedback element, and A is an amplifier with the gain of A.

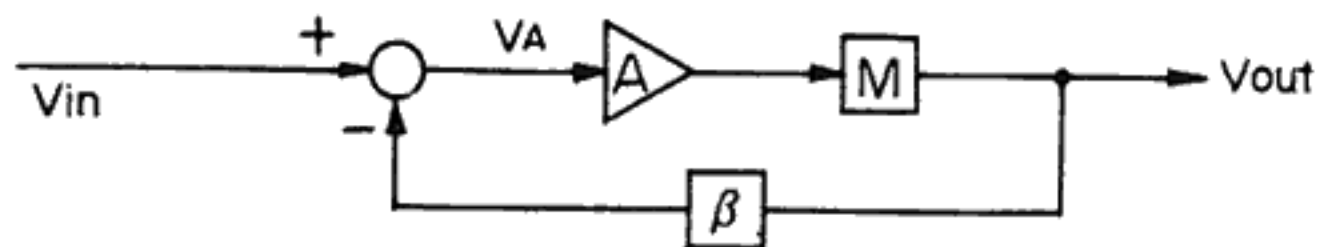

Based on the above figure, we obtain the following formula

$$V_{out} = V_A \times A \times M$$

V_{in} : input voltage

V_A : amplifier input voltage

V_{out} : output voltage

V_A is expressed as follows:

$$V_A = V_{in} - \beta V_{out}$$

Therefore, the closed loop gain G1 can be written as:

$$\begin{aligned} G1 &= V_{out}/V_{in} \\ &= V_A \cdot A \cdot M / (V_A + \beta V_A \cdot A \cdot M) \\ &= A \cdot M / (1 + \beta A \cdot M) \end{aligned}$$

If the amplifier is assumed to be an ideal amplifier with an infinite gain, then we obtain:

$$G1 = 1/\beta$$

That is, the closed loop gain is a reciprocal of β which is always constant regardless of control object M

The negative feedback is thus able to suppress unstable factors involved in the control object by using a stable feedback element and ideal amplifier.

S-V SERVO

In conventional speed control systems, speed-information feedback depends on a voltage proportional to the frequency. Therefore, its closed-loop characteristic has usually a poor linearity as shown in the following figure.

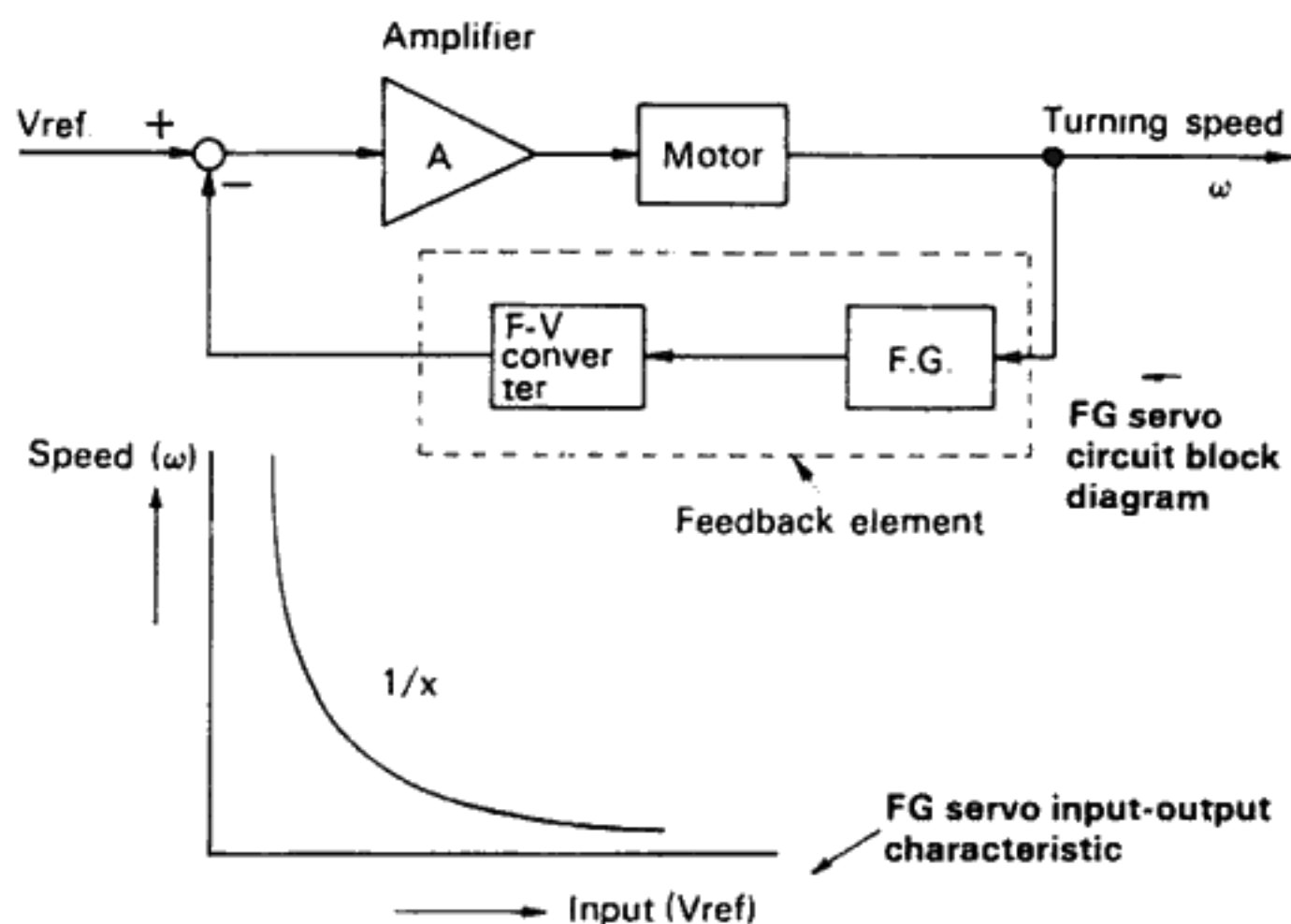

Our KD-750 and KD-650 (600) Turntables employ not only the S-V servo system, which is an improved version of the conventional speed control system, but also the

phase-feedback control system. The S-V servo system uses a Speed-Voltage converter which generates a voltage reversely proportional to the motor's turning speed and provides an ideally linear input-output characteristic.

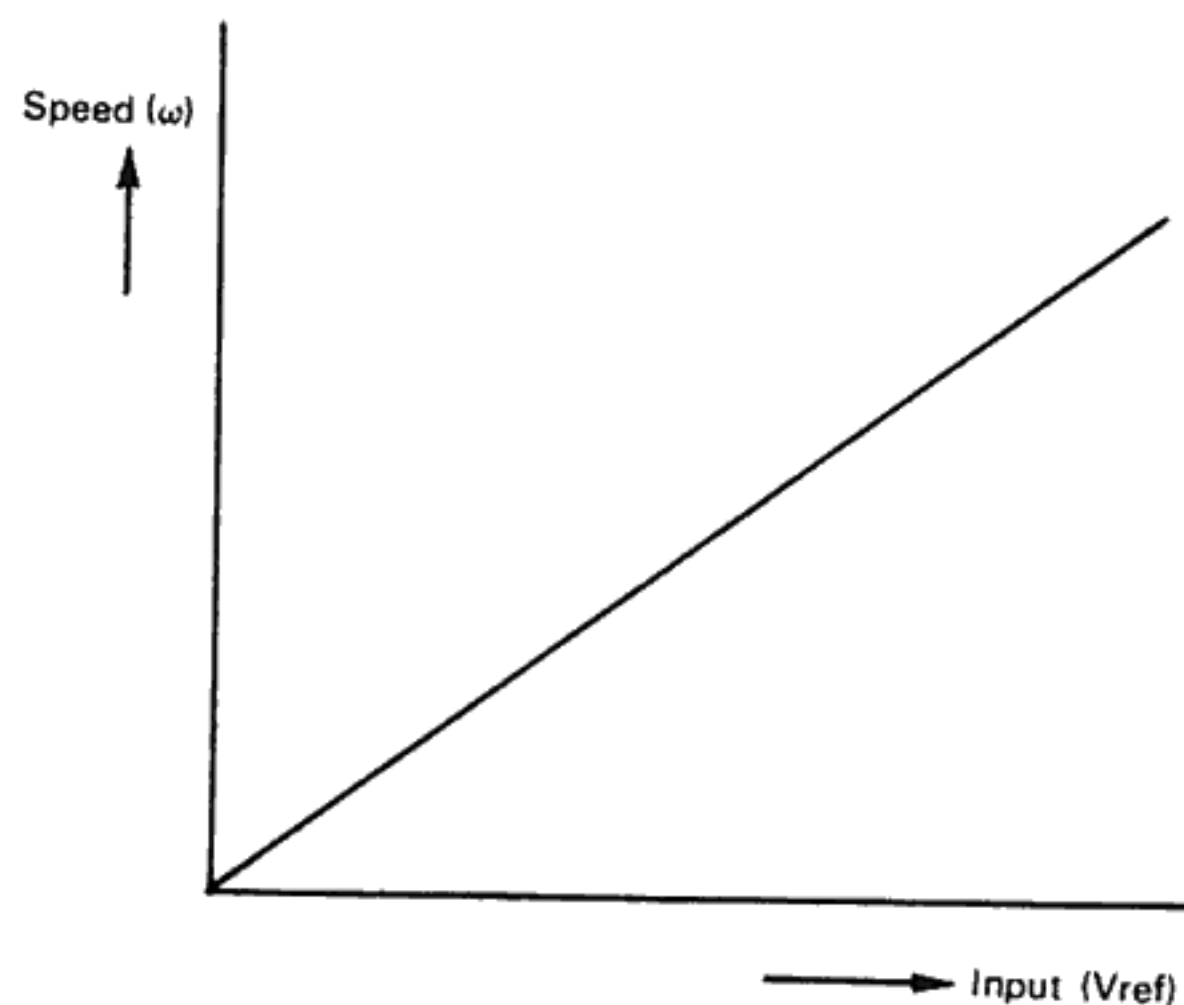

S-V Servo Input-output Characteristic

PLL

The PLL, a kind of phase feedback circuit, controls the output phase of the voltage-controlled oscillator located within the closed loop to coincide with the phase of the reference frequency. The following figure shows a basic block diagram of the PLL:

This filter passes only the frequency close to the VCO frequency. If there is any phase difference, a voltage is generated.

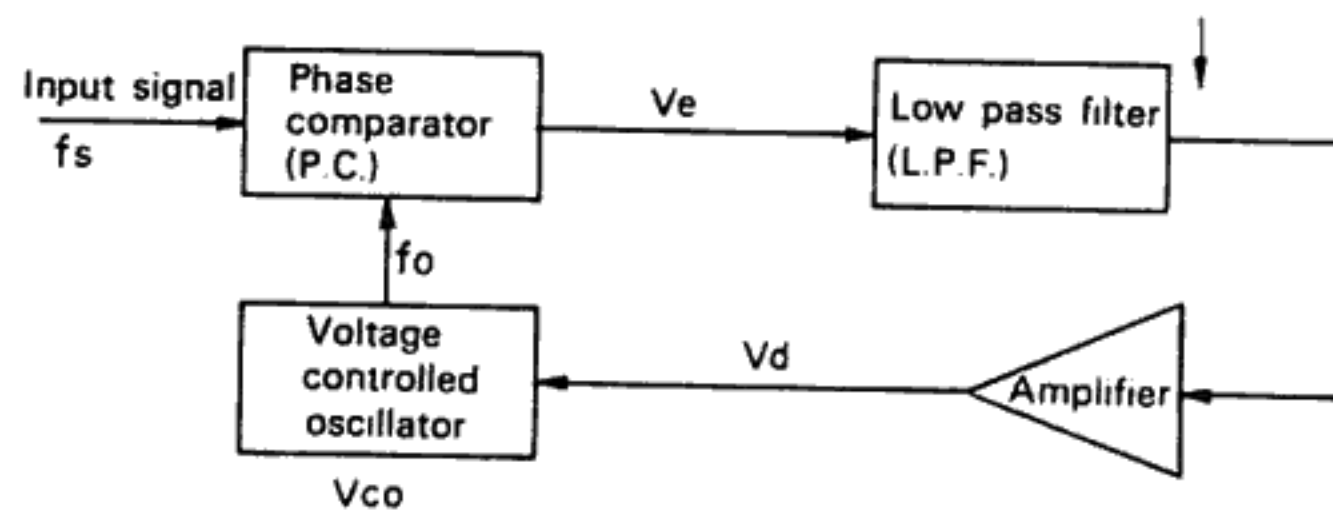

PLL Basic Configuration

In the above figure, the phase comparator generates a voltage corresponding to the phase difference between the input signal and the VCO (Voltage-Controlled Oscillator) output. There are an analog and digital phase comparator now available. It is sometimes called a phase detector. The voltage-controlled oscillator oscillates a frequency proportional to the input voltage. Its output is coupled to the phase comparator to constitute a PLL feedback loop. The low pass filter (LPF) in the loop suppresses harmonic components and noises contained in the phase comparator output. The response and synchronization characteristic of the PLL largely depend on this LPF characteristic.

The synchronization process taking place in the PLL loop consists of two stages: frequency pull-in process (in which the VCO output frequency approaches the reference frequency) and lock-in process (in which the VCO output is locked to the reference frequency).

CIRCUIT DESCRIPTION

FREQUENCY PULL-IN PROCESS

When f_s and f_0 in the PLL basic block diagram are different from each other (phase difference is large), the phase detector operates as a mixer because of its non-linear characteristic, and generates a beat signal equivalent to the frequency difference. If this beat frequency is below the specific value inherent to the PLL loop characteristic, the VCO output frequency approaches to the reference frequency until finally the former is locked to the latter. However, if the frequency difference is too large, the VCO output is not synchronized with the reference frequency by repeating approach to and departure from the reference frequency. The following figure illustrates the PLL synchronization process viewed from the phase comparator output.

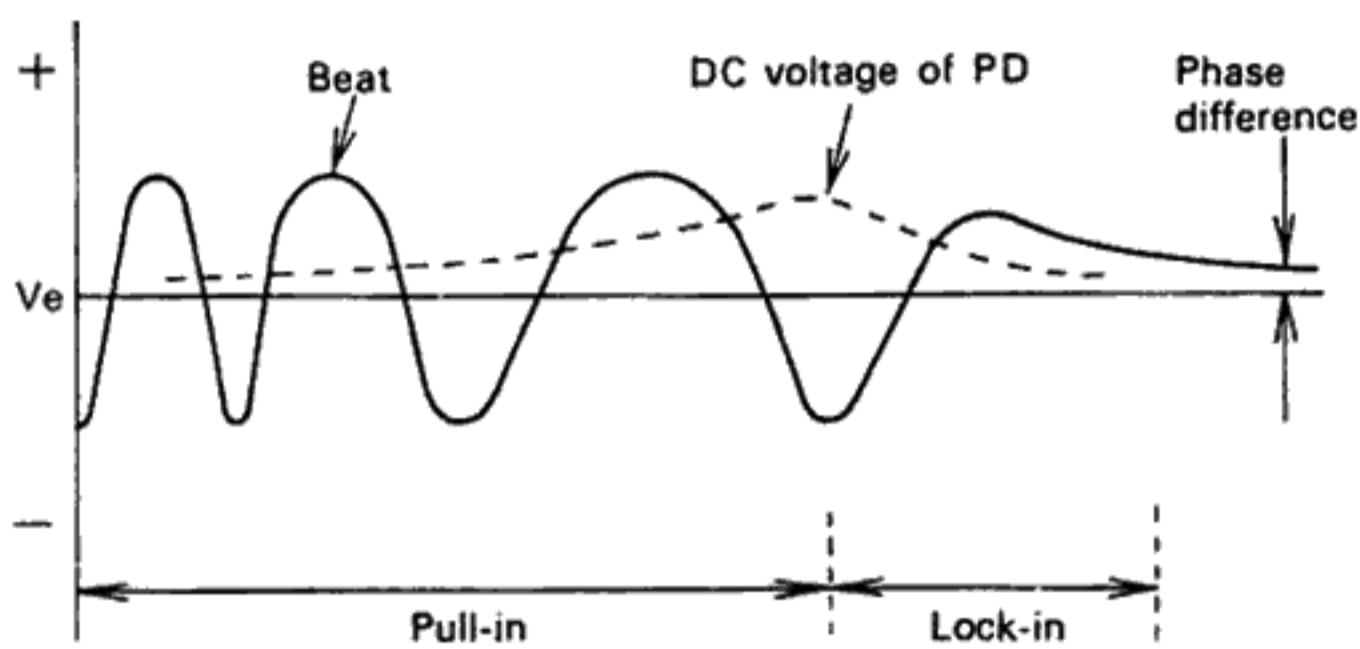

Phase Output in PLL Synchronization Process

LOCK-IN PROCESS

The frequency difference reduced in the pull-in process is further reduced in the lock-in process until the PLL can completely respond to the beat frequency and finally the VCO output is synchronized with the reference frequency.

LOCK RANGE AND CAPTURE RANGE

The PLL voltage-frequency conversion characteristic (a) shown in the following figure indicates the case where input frequency f_s is higher than reference frequency f_0 . The loop does not respond until input frequency f_s reaches f_1 . However, when f_s reaches f_1 , the loop is suddenly locked to f_s and generates a negative difference voltage V_{d1} which varies proportional to the reciprocal of conversion gain k_0 (V/rad) of the VCO as the frequency increases. And when f_s is equal to f_0 , when f_s reaches f_2 via V_{d0} , V_d rapidly returns to zero, thus releasing the lock. It is this frequency f_2 that is the upper limit of the lock range.

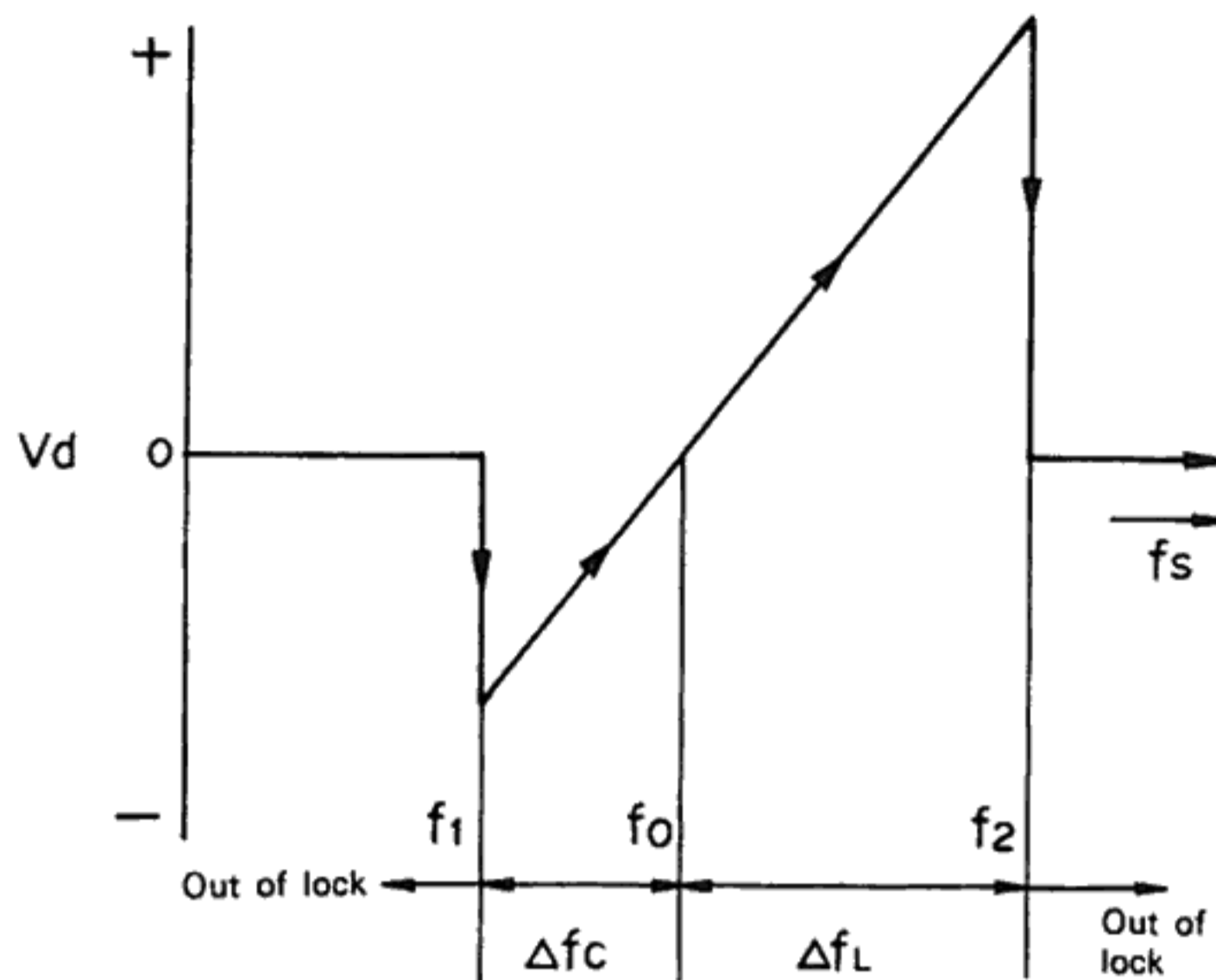

< a: as input frequency f_s is increased >

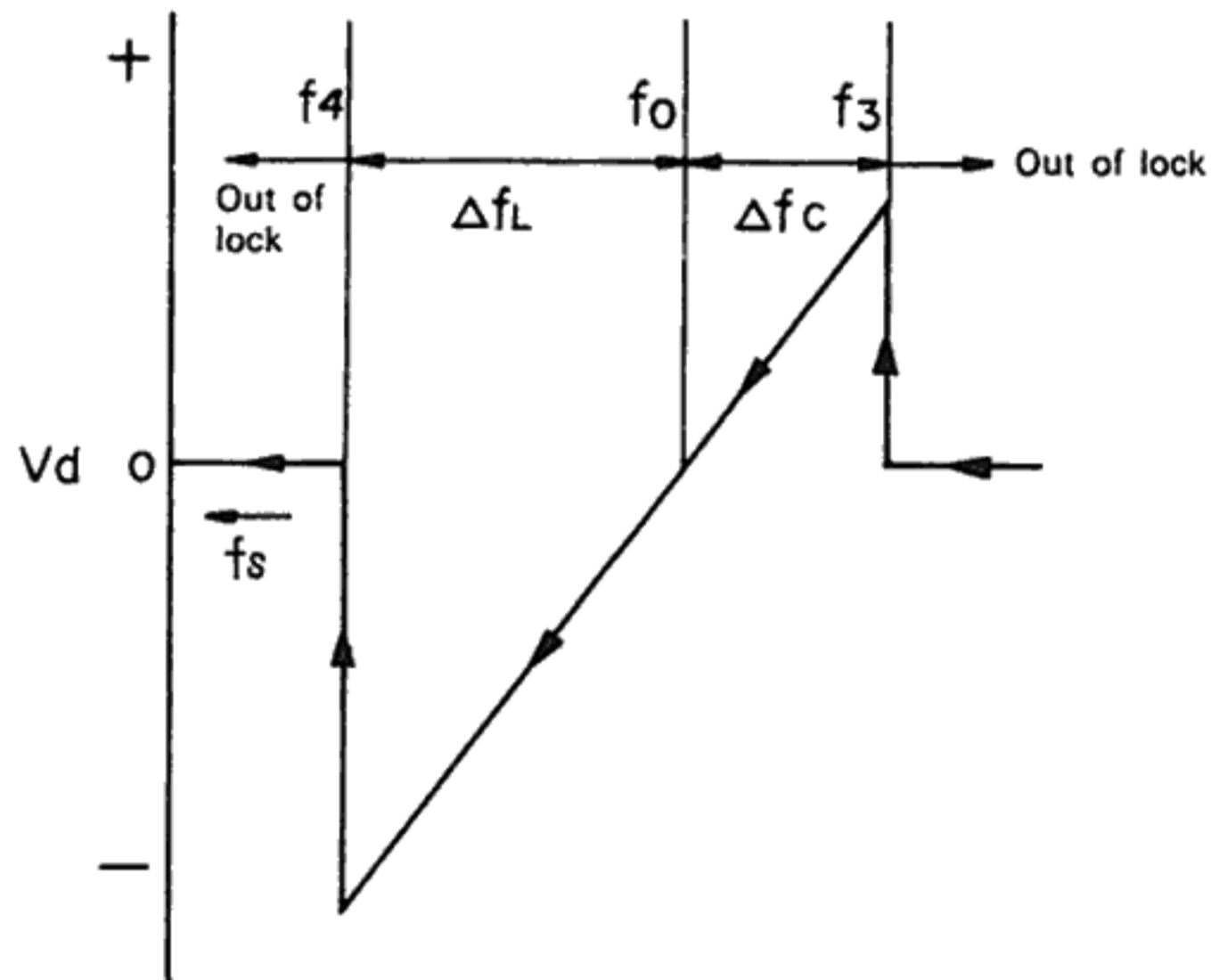

< b: as input frequency f_s is decreased >

From the above figure, the capture range and lock range are expressed as follows.

$$\text{Capture range: } f_3 - f_1 = 2\Delta f_c$$

$$\text{Lock range: } f_2 - f_4 = 2\Delta f_L$$

From the above descriptions, it may be concluded that the PLL responds only to the frequencies apart from $\pm\Delta f_L$ or Δf_c from the VCO output frequency f_0 , and when it responds, the PLL is locked in.

CIRCUIT DESCRIPTION

QUARTZ LOCK PLL

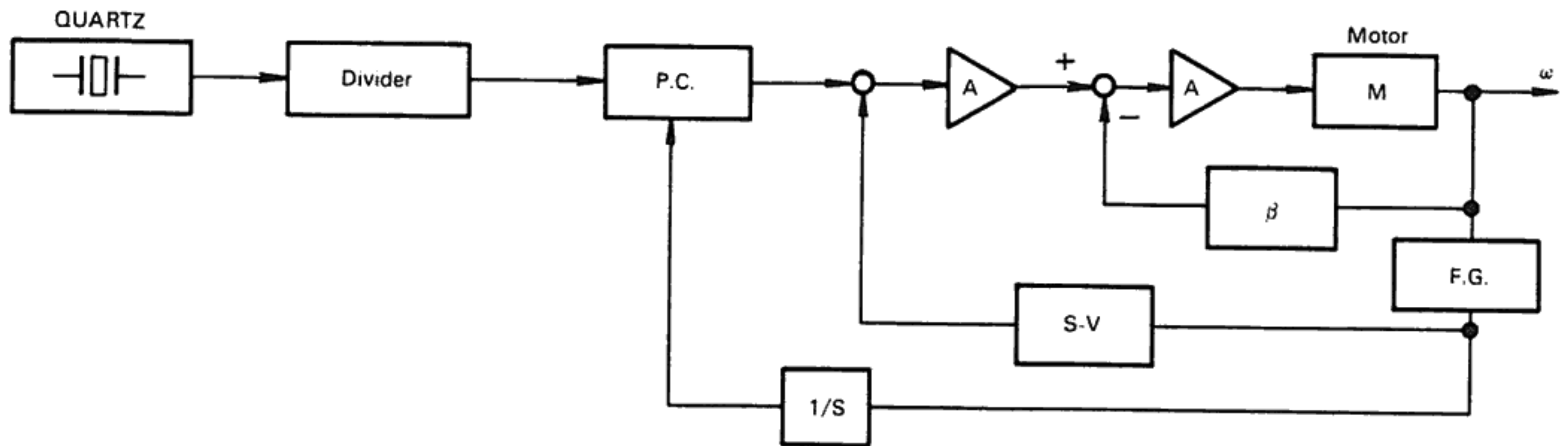

Block Diagram for Quartz Lock PLL.

From the above figure, it is known that the control circuit is composed of three basic closed loops: the inner-most constant current loop constituting the motor driver section, the outer S-V converter closed loop to control turning speed, and the outer-most phase-comparator closed loop to control phase. The quartz crystal controlled oscillator oscillating the reference frequency for the phase comparator provides a higher precision motor control.

OPERATION CONTROL SECTION

When turntable operations, such as start, stop and speed change, operating mechanisms in conventional turntables have given undesirable vibrations to the turntable. In order to eliminate such unnecessary vibrations, the KD600 (650) Turntable has incorporated "touch" switches into its operating section.

The following diagrams cover some technical descriptions for an integrated circuit (IC) designed to aid the touch switch operation.

The SAS-560S, a monolithic IC designed to aid the touch switch operation, requires only a very small operating current. It has four independent inputs, and two outputs corresponding to each input. The following table shows the pin configuration of the SAS-560S.

Channel	Input	Output	Application
1	10	6. ⑨	STOP
2	12	5. ⑪	45 rpm
3	14	4. ⑬	33 rpm
4	16	3. ⑮	

Pin numbers enclosed in a circle indicate those for turning-speed display output.

SAS-560S IC Pin Configuration

TOUCH SENSOR (SAS-560S)

This IC includes 4 control circuits as shown in the diagram below. (Refer to page 18.)

The point 14 is the sensor input which is normally biased by +B through 560 kΩ, turning Q202, Q203, Q206, Q207, Q210-Q215, Q208 and Q208 to OFF and Q204 and Q205 to ON, so no voltage is present at the points 13 and 4.

By touching the sensor input 14, a current flows through 4.7 MΩ, turning Q202 to ON which, in turn, turns Q204 and Q205 to OFF and Q206, Q207, Q210-Q215, Q208 and Q209 to ON, so that an output voltage is developed at the point 13 and 4.

By releasing the sensor input 14, Q202 and Q203 turn to OFF and Q204 and Q205 turn to ON; Q206 also turns to OFF, while Q207 is locked in ON state by Q208 and Q209 (a positive feedback loop is formed by Q207, Q208 and Q209). Since Q210-Q215 remain ON, the output voltage is still present at the points 13 and 4 when the sensor input is released. These circuits can be unlocked by increasing the voltage at the point 2.

Q206, Q207, Q106, Q107, Q306, Q307, Q406 and Q407 each are connected to a common emitter with an external load resistor, so when any one of the 4 circuits is locked, the remaining circuits are unlocked because the voltage at the point 2 is increased.

There are no possibilities of locking more than one circuit at the same time (see the circuit diagram of SAS560S, P18).

When the power is ON, the output voltage is first developed at the points 6 and 9 since Q507 and Q508 are momentarily turned ON through the circuit Q504-Q508 which functions as a start switch. As the emitter of Q508 is connected to the base of Q408, Q408 turns ON which, in turn, locks Q407, Q408 and Q409 in ON state.

CIRCUIT DESCRIPTION

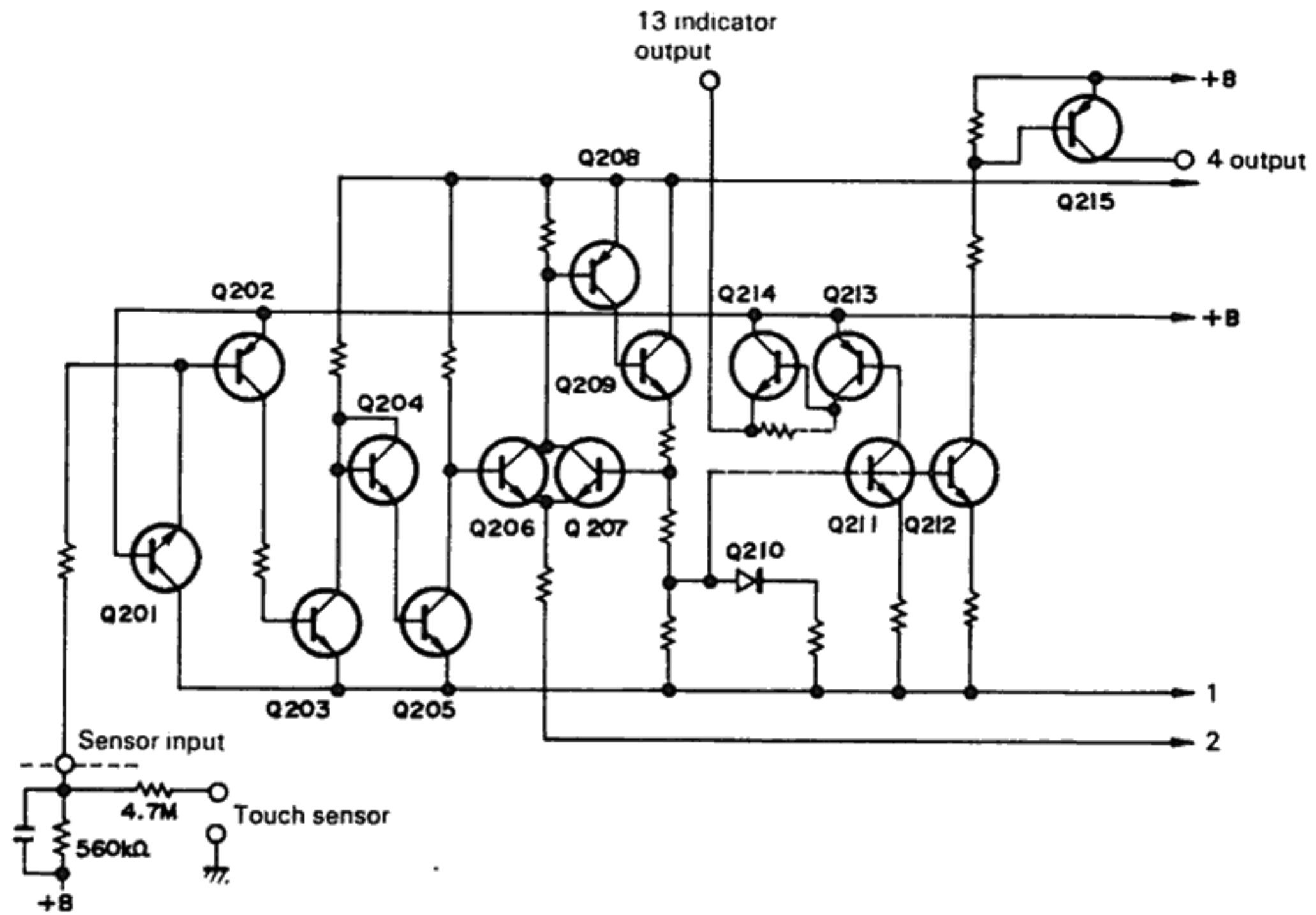

Channel-1 in the IC incorporates a power-set (initializing) circuit which resets the entire turntable mode into the STOP mode when the power of the turntable is turned on. The output of pin-9 is used for stop-operation signal, while those

of pin-5 and pin-6 are used for turning-speed selection signal. Outputs pin-9 and pin-11 are coupled to transistors Q15 and Q16 respectively which drive turning-speed indicator LEDs.

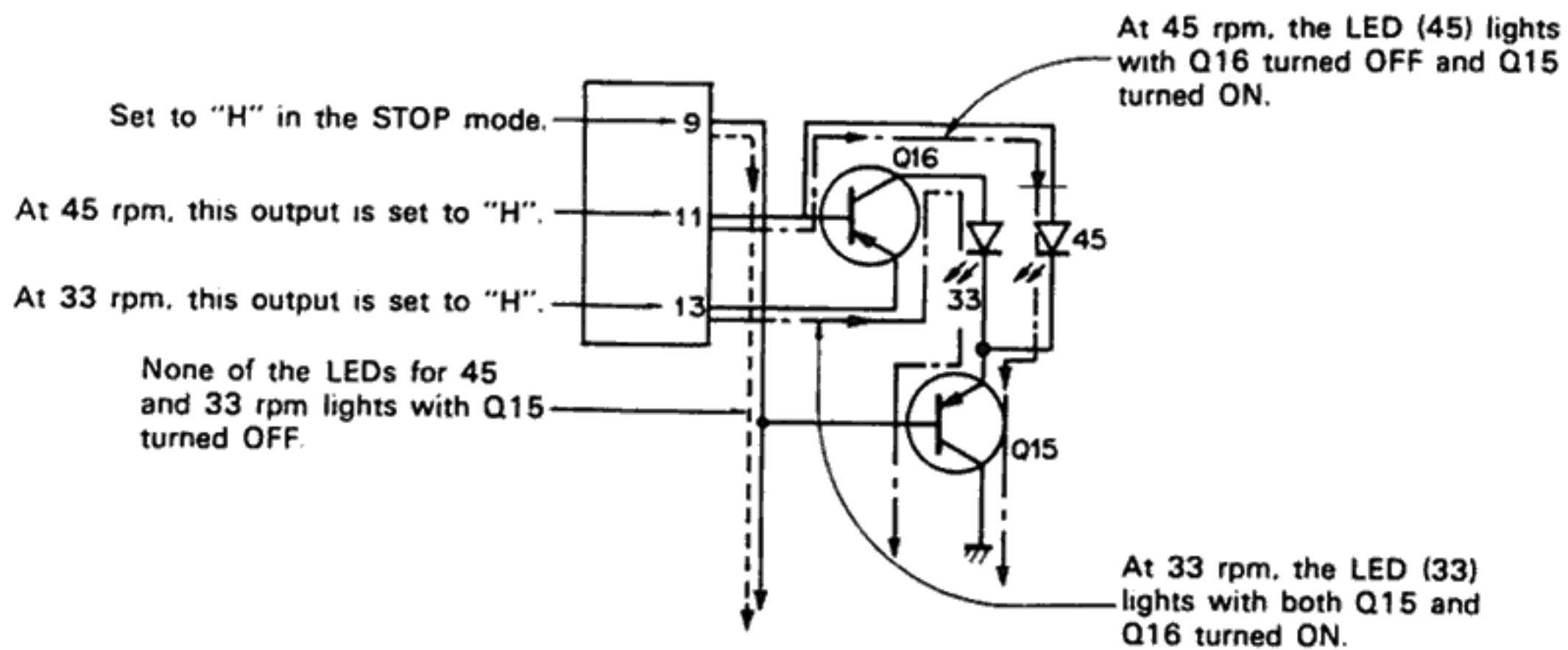

Turning-speed Indicator LED Drive Circuit

SPEED-MONITORING CIRCUIT

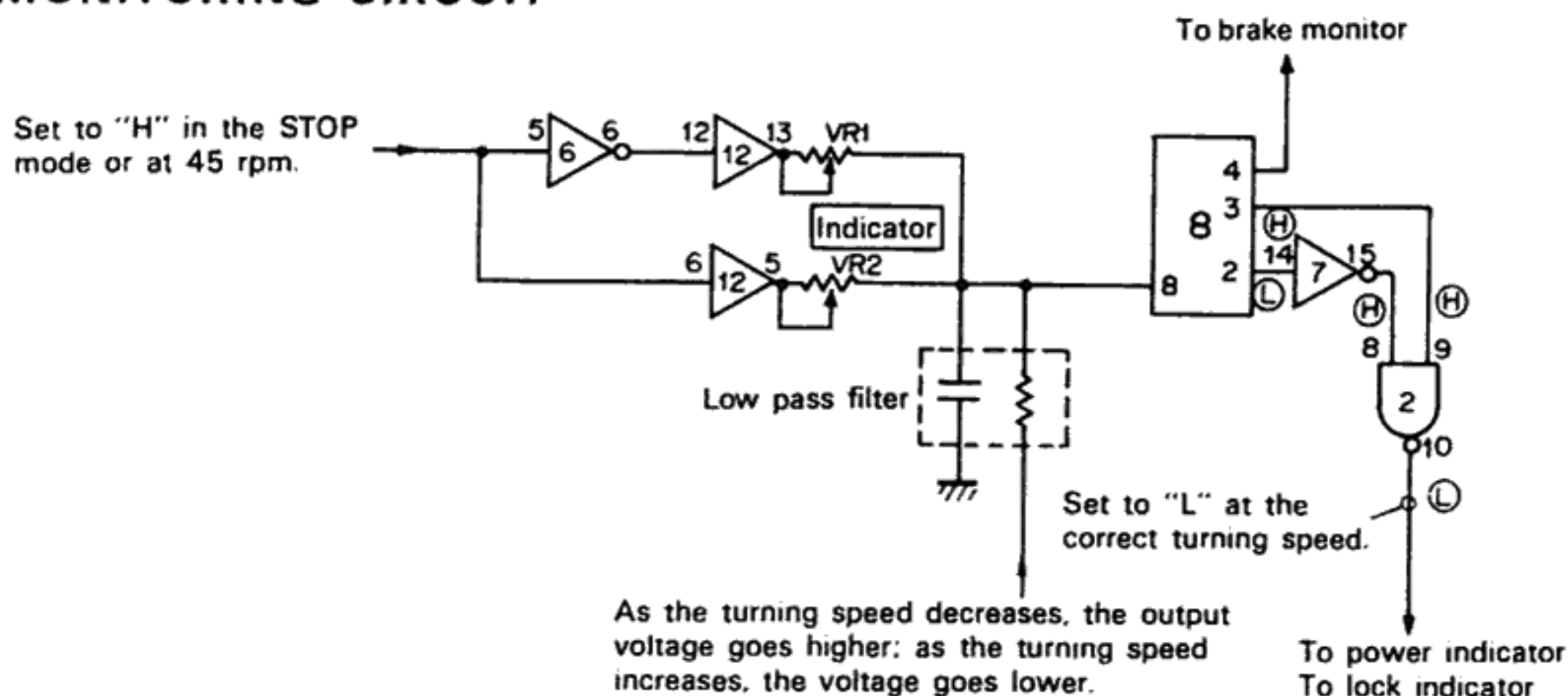

CIRCUIT DESCRIPTION

The Speed-Monitoring circuit monitors motor rotation for correct turning speed. The outputs of the circuit become the control signals for the power indicator, lock indicator, and brake-monitor circuit. Pin-8 of IC8 accepts the voltage from IC1 and the FG signal, which is S-V converted and passed through a low-pass filter, proportional to motor rotation. IC8 is an analog level comparator, i.e. an A/D converter, of which logical output pins 2, 3 and 4 are connected to each logic circuit. The input/output characteristics of the 5-step analog level comparator is shown in the following table:

Analog Input	Q1	Q2	Q3	Q4	Q5	Motor Rotation
Terminal 8	Terminal 2	Terminal 3	Terminal 4	Terminal 5	Terminal 6	
< 200mV	H	H	H	H	H	Turning speed too high
200 ~ 400mV	L	H	H	H	H	Correct turning speed
400 ~ 600mV	L	L	H	H	H	Turning speed too low
600 ~ 800mV	L	L	L*	H	H	
800 ~ 1000mV	L	L	L	L	H	
> 1000mV	L	L	L	L	L	
Output Application	Lock indicator Power indicator	brake monitor	No connection			

* Turning speed of less than 0.144 rps (brake signal is released)

Input/Output Characteristics of the 5-step Analog Level Comparator

The input, pin-8, of the analog comparator is adjusted with trimming potentiometer VR1 and 2 so that the output, pin-4, is "H" with the correct turning speed and that is "L" with less 0.144 rps. Together with this input voltage adjustment, brake turn-off timing (to eliminate the brake control signal) is also adjusted. (Refer to the "Brake Monitor Circuit".)

LOCK INDICATOR CIRCUIT

The Lock Indicator circuit drives the lock indicator lamp when the motor is locked to the correct turning speed with the constant phase difference. The circuit requires four different input signals to drive the indicator as illustrated below.

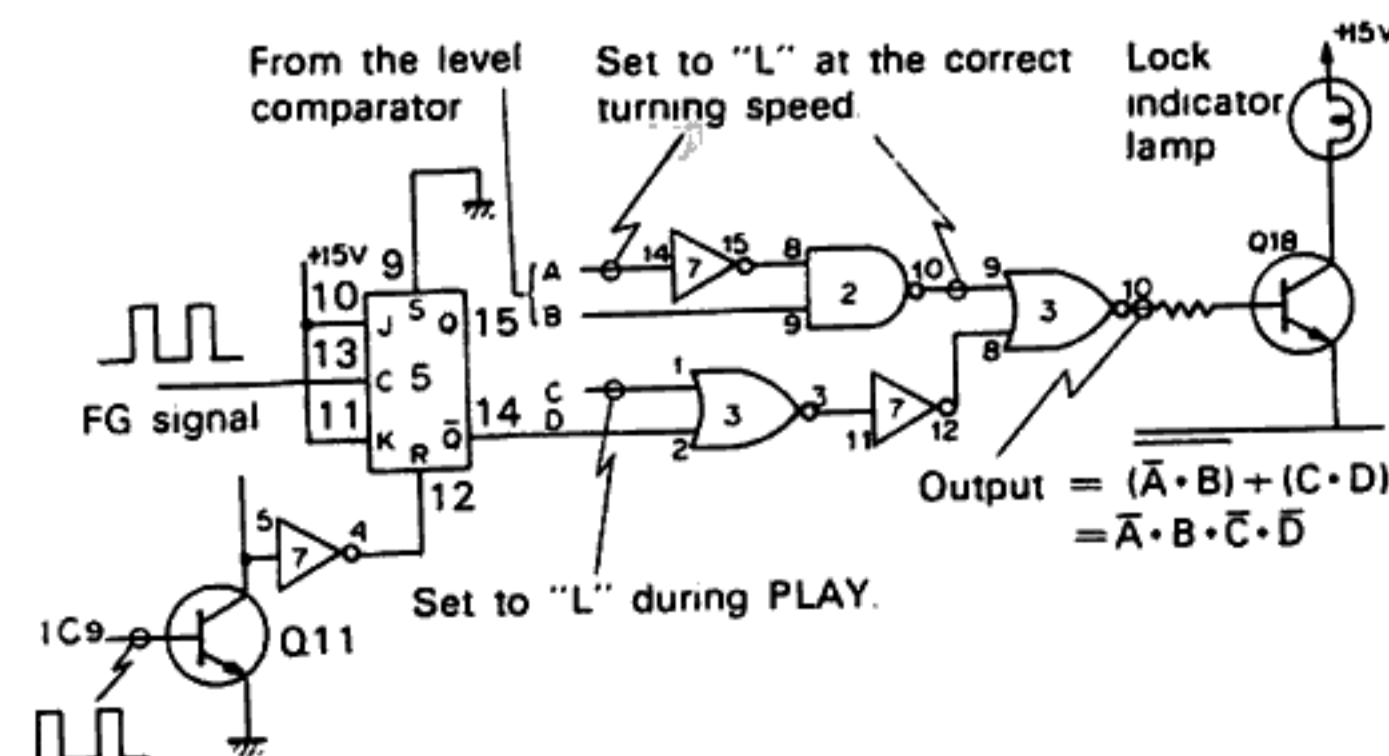

When the motor is turning at the correct turning speed, inputs A and B in the above figure are set to "L" and "H" respectively. Pin-9 of IC3 set to "L". Meanwhile, pin-8 of IC3 accepts a square wave and the square wave causes the output level of pin-10 to repeat "H" and "L" alternately. As a result, the lock indicator lamp, driven by transistor Q18, is "dynamically" lit. Actually the lamp blinks, but the blinking period is so rapid and the illuminance level is so constant that it appears as if the lamp constantly lights.

Now let us think of the input signal to pin-8 of IC3. When the motor starts turning, an FG signal is applied to the clock input of IC5, and a signal S-V converted from the FG signal is applied to its reset terminal via Q11 and inverter IC7. Then the \bar{Q} output of IC5 is connected to pin-8 of IC3. The clock input of IC5 accepts a square wave while its reset terminal accepts a pulse signal as shown in the following timing chart:

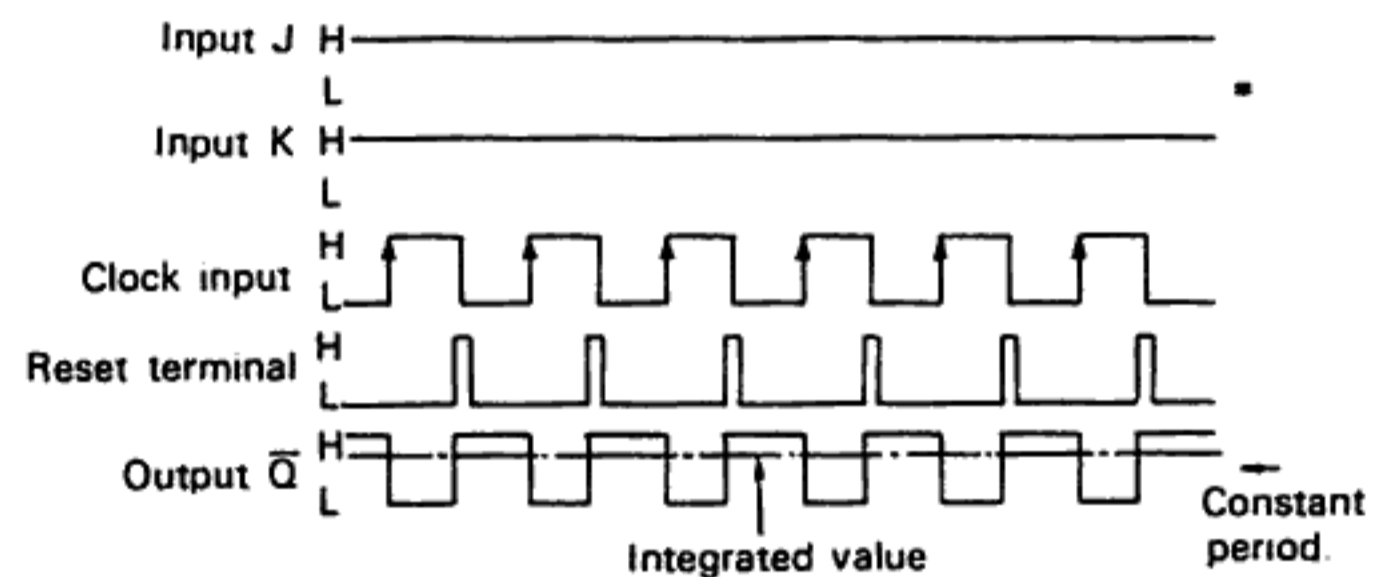

* When both the J and K inputs are pulled up to "H" level, every clock input triggers the output into the reverse state.

Output \bar{Q} of IC5 is connected to pin-2 of IC3. As a result, an inverted square wave is obtained on output pin-3 of IC3 since the other input pin-1 of IC3 is always set to "L" in the PLAY mode. Pin-8 of IC3 accepts the square wave via inverter IC7 and its output pin-10 repeats "H" and "L" alternately as described previously.

The following figure illustrates what happens if the FG signal has an irregular period:

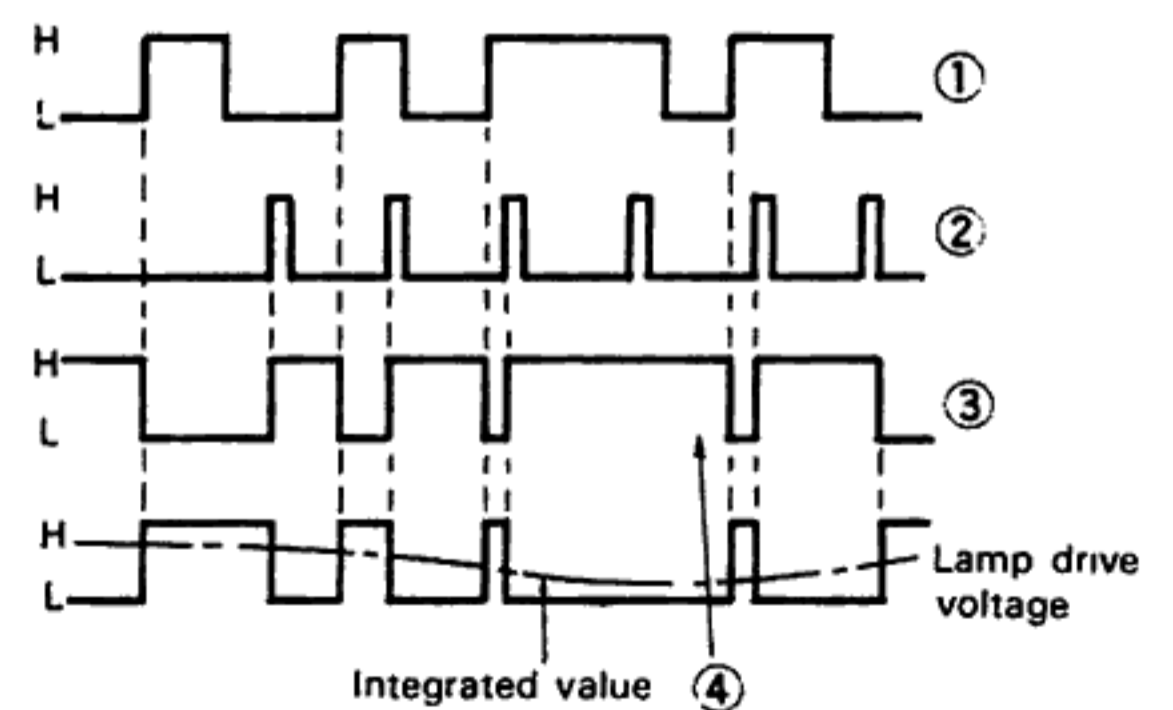

- ① FG signal (implies irregular motor rotation)
- ② Reset pulse (with constant period)
- ③ \bar{Q} output waveform
- ④ Since the period of reset pulse is not regular, the lock indicator appears to be blinking (lock is "out").

Lock Indicator Operation with Irregular FG Signal

CIRCUIT DESCRIPTION

BRAKE MONITOR CIRCUIT

Unlike conventional brake circuit in which brake signal is generated by a time-constant circuit, KD-600 (650)'s brake circuit generates brake signal by using the STOP signal, and releases the brake when turntable platter rotation is reduced /

less than 0.144 rps. In the STOP mode and also the turntable platter because of setting the reset terminal of IC4 to "H" turned less than 0.144 rps, the brake signal generator IC (IC4) generates no signal /

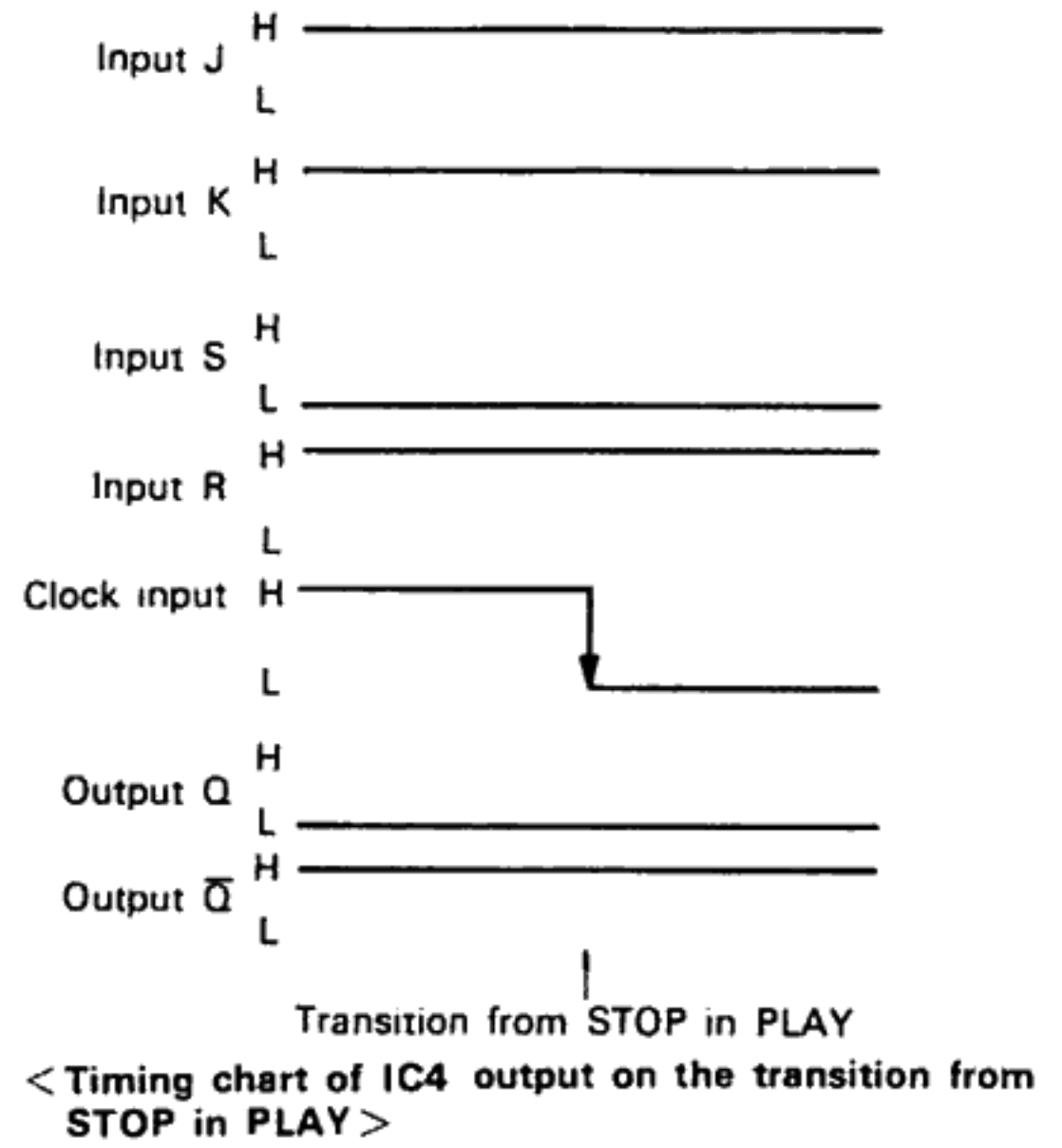
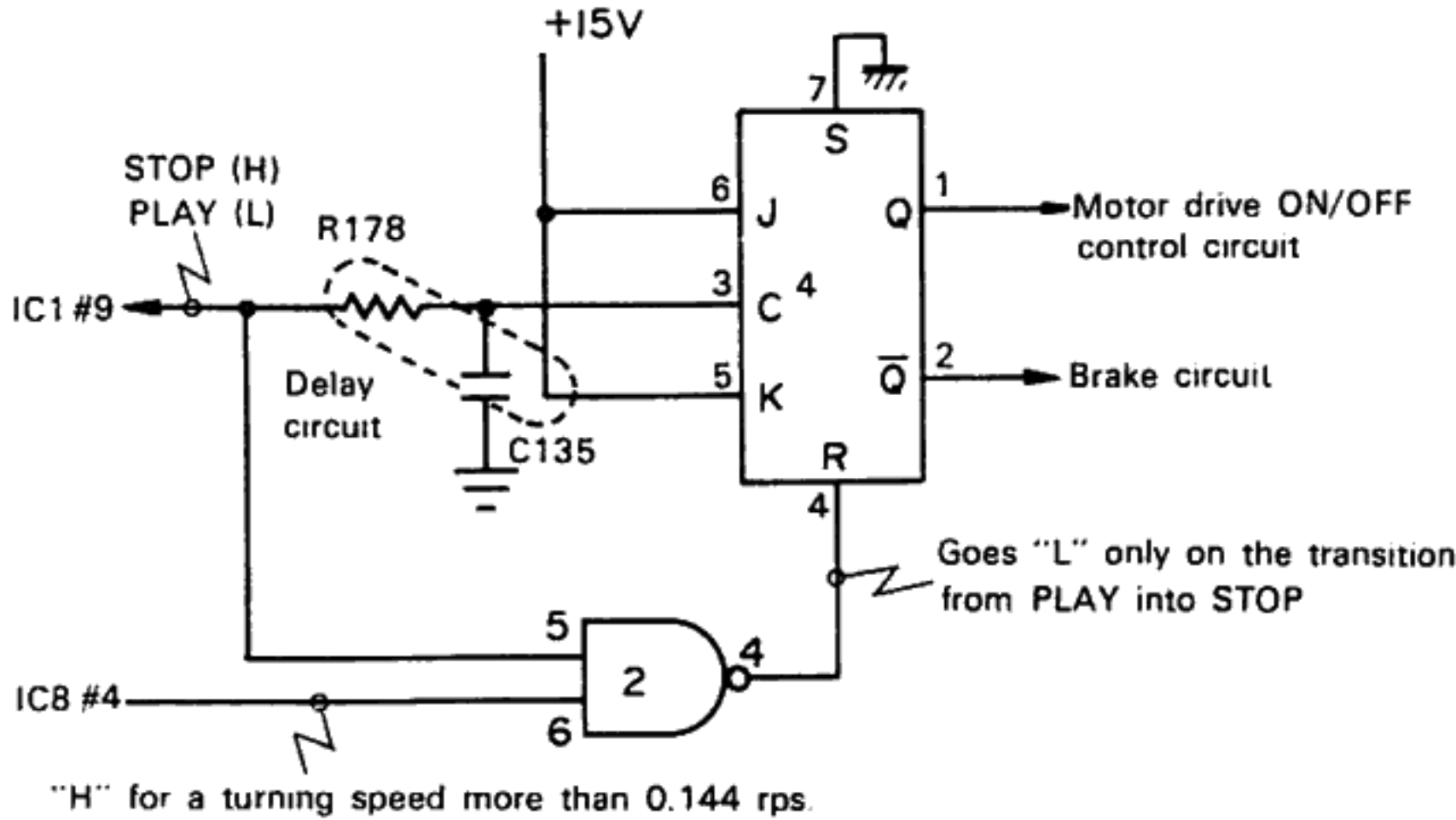

This state remains unchanged when the mode is switched from STOP into PLAY. In other words, outputs of IC4, Q and \bar{Q} do not change their state.

On the other hand, when the mode is switched from the PLAY into STOP mode, the brake signal generates. First, IC1 generate STOP signal, but the motor continues turning because of the turntable platter's inertia. Then the both inputs of IC2, NAND gate, go "H" and its output pin-4 goes "L" when the turntable platter rotation is reduced to 0.144 rps or below. The clock input of IC4 goes, of course, "L" to "H". Since IC4 is a positive going edge triggering J-K flip-flop (refer to the service manual for the KD-750), its outputs Q and \bar{Q} reverse their states on the positive going edge of the clock input, and hence the brake signal generates. The brake signal goes to the brake circuit where it is connected to input pin-3 of IC13, bringing the turning direction selection circuit into the reverse mode. The following figure shows a timing chart on the transition from the PLAY into STOP mode.

Meanwhile, when motor rotation speed is lower than the specified speed, output, pin-4 of IC8, (level comparator) goes "L", causing the output of IC2 NAND gate to go "H", and the reset input of IC4 to do "H" and outputs Q and \bar{Q} is forced into "L" and "H" respectively without clock input signal. In this case, therefore, the brake signal does not generate.

The following figure illustrates the input state of the J-K flip-flop on the transition of brake signal issuing.

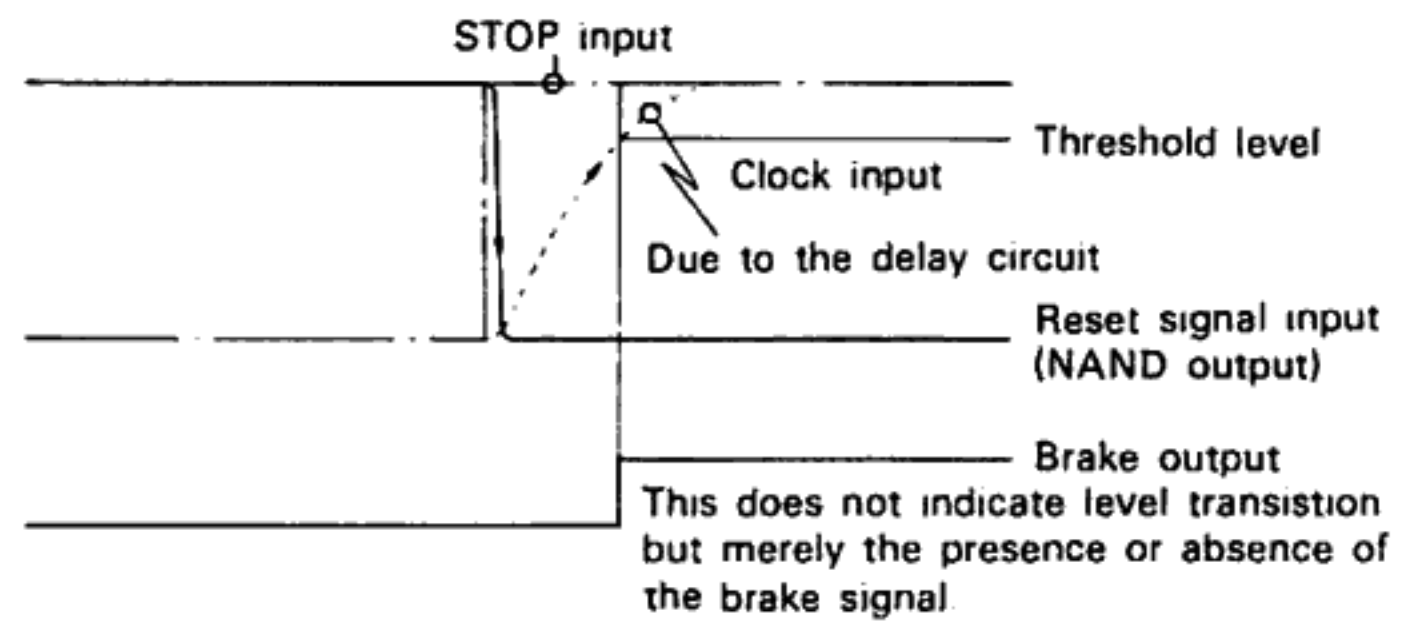

< When motor rotates at more than 0.144 rps. >

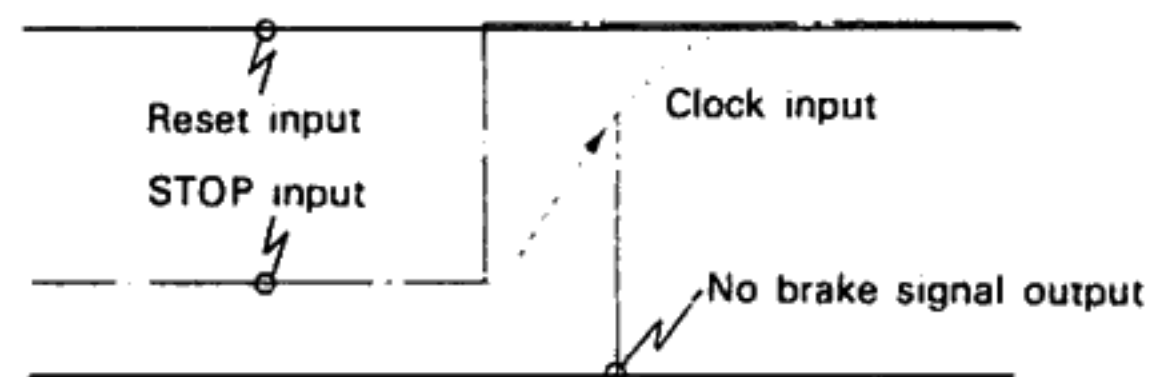

< When motor rotates at below 0.144 rps. >

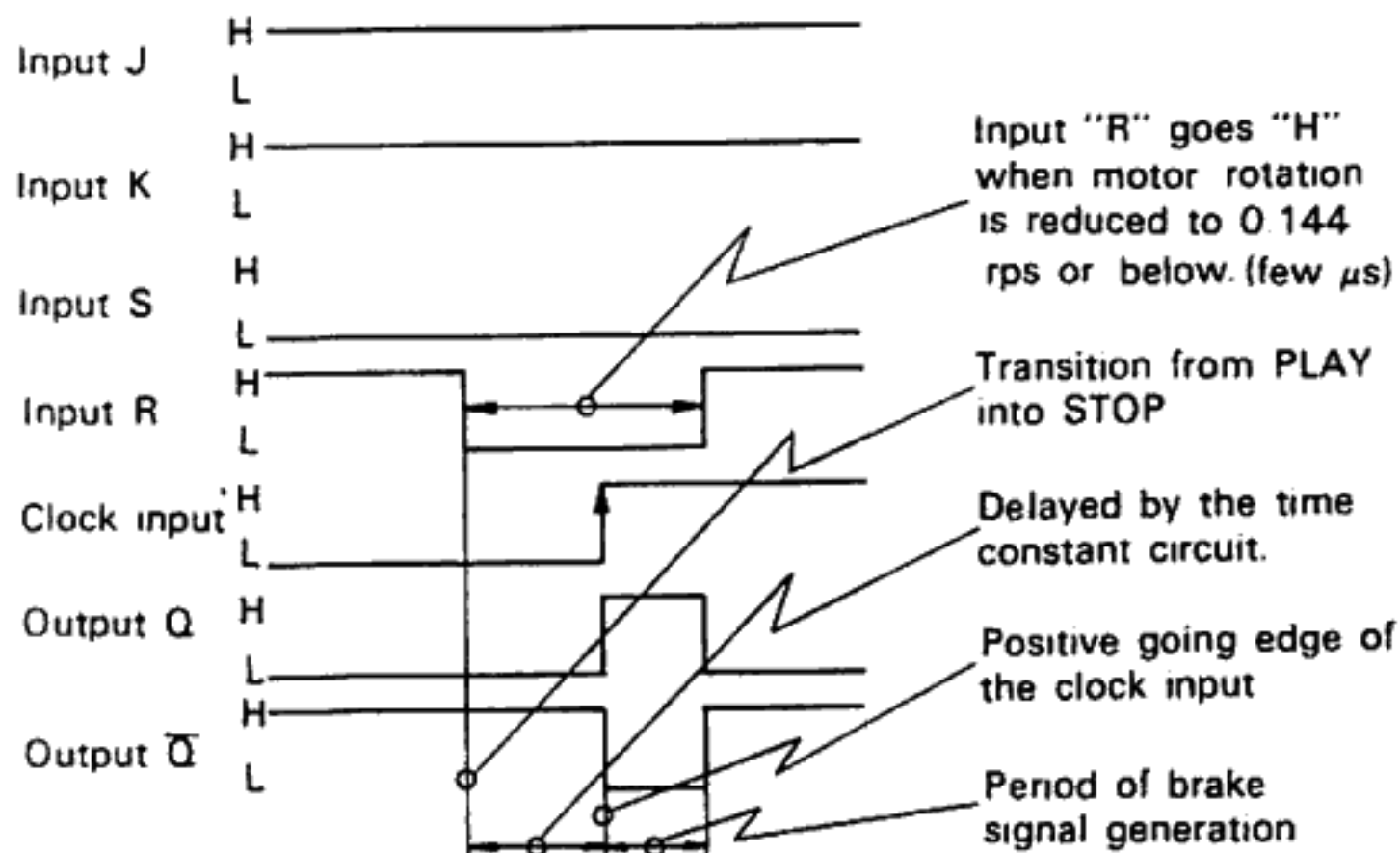

Brake Signal Generation Timing Chart

In addition, the circuit goes into the 45 rpm state in the STOP mode. Therefore, the timing to turn off the brake signal is determined by VR1. If VR1 is out of adjustment (the optimum adjustment value is 265 mV d.c.), particularly set

CIRCUIT DESCRIPTION

too low, the brake signal remains on when the brake is turned off, causing the motor to turn in the reverse direction. Then the reversal prevention circuit operates to reverse the motor rotation into the normal direction. The normal and reverse rotations are, thus, repeated until the proper adjustment of VR1 is accomplished. Conversely, if VR1 is set to too high, period of generating the brake signal is shorter than normal condition, causing the motor not to be slow turning.

BRAKE CIRCUIT

The brake circuit generates a control signal for input pin-3 of IC13 by using the brake-monitor and turning direction monitor signals.

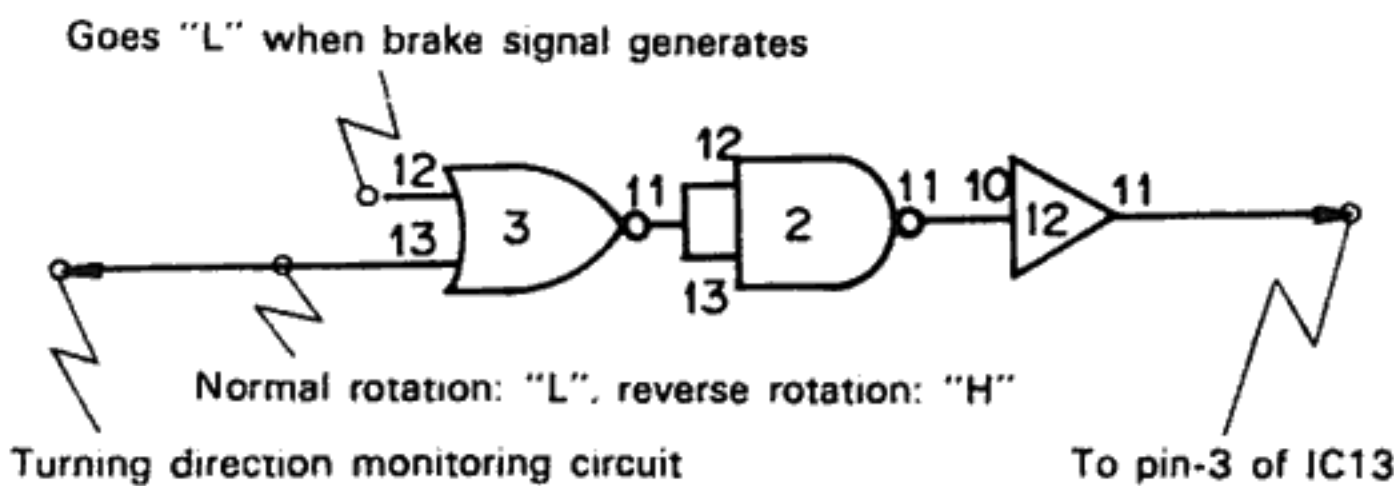

Input pin-12 of IC3 is connected to output \bar{Q} of the brake monitor circuit. When the brake signal is generated, input pin-12 of IC3 is set to "L". The other input pin-13 of IC3 is also set to "L" since the motor rotates in the normal direction. Output pin-11 of IC3 is, therefore, set to "H", and is inverted through an inverter (IC2), then connected to input pin-3 of IC13 as an "L" level. When an "L" level is applied to pin-3 of IC13, the zero-cross comparator generates a reverse command to cause a braking force to the motor rotation.

POWER INDICATOR CIRCUIT

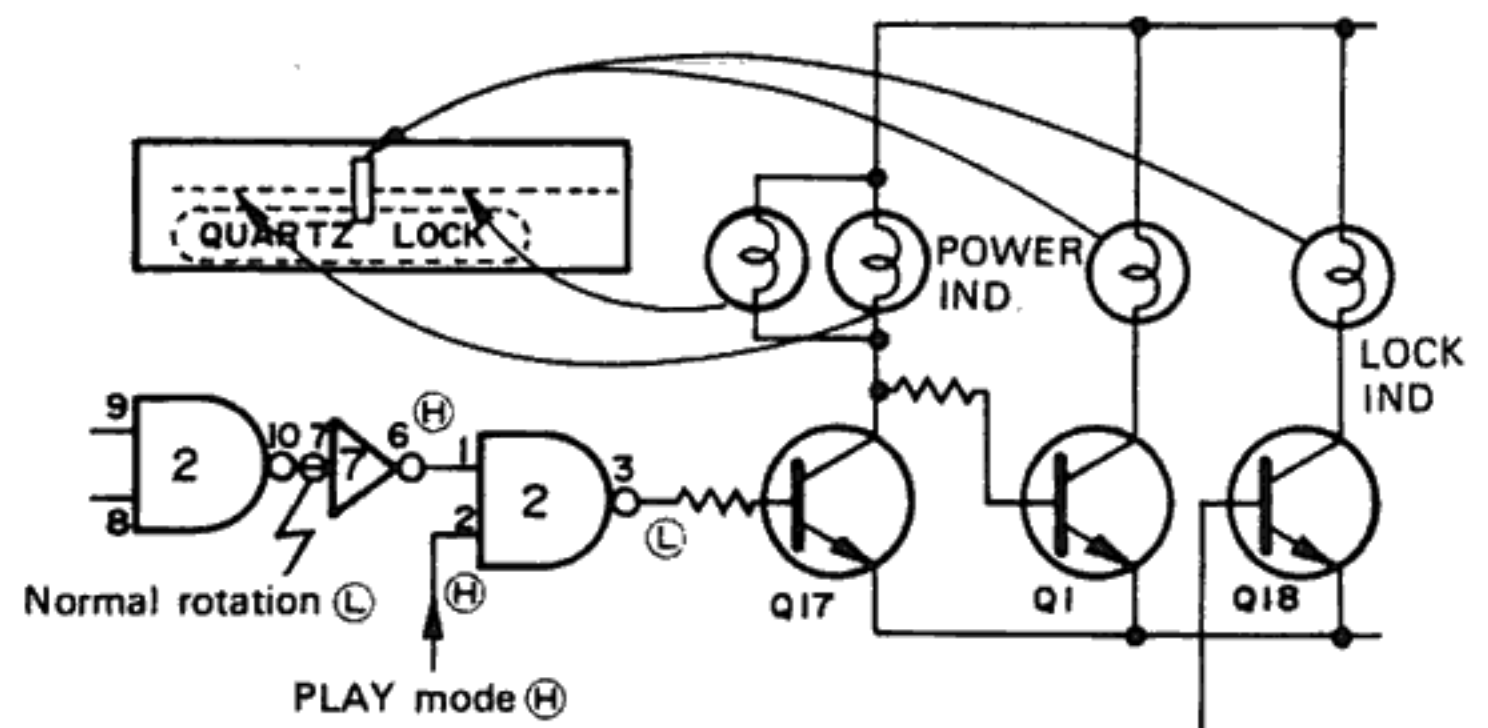

The power indicator circuit not only drives the power indicator lamp when the power of the turntable is turned ON, but turns OFF the power indicator when the motor is locked into the normal rotation.

There are four indicator lamps in the turntable. Two of these are power indicators, and two of the reset is used to indicate the lock indicator's center line.

When the power of the turntable is turned ON, both inputs, pin-1 and pin-2 of IC2, go "L", bringing its output pin-3 to "H". And Q17 is turned ON while Q1 is turned OFF. This causes the power indicator lamp to turn ON.

When the turntable is put into the PLAY mode, both inputs, pin-1 and pin-2 of IC2, go "H" and hence its output pin-3 goes "L", bringing Q1 to turn ON and Q18 to turn OFF.

This causes the center line for the quartz lock to illuminate along with the LOCK indicator, indicating that the turntable is quartz locked to the normal speed.

CONTROL CIRCUIT SWITCHING MOTOR DRIVE CIRCUIT

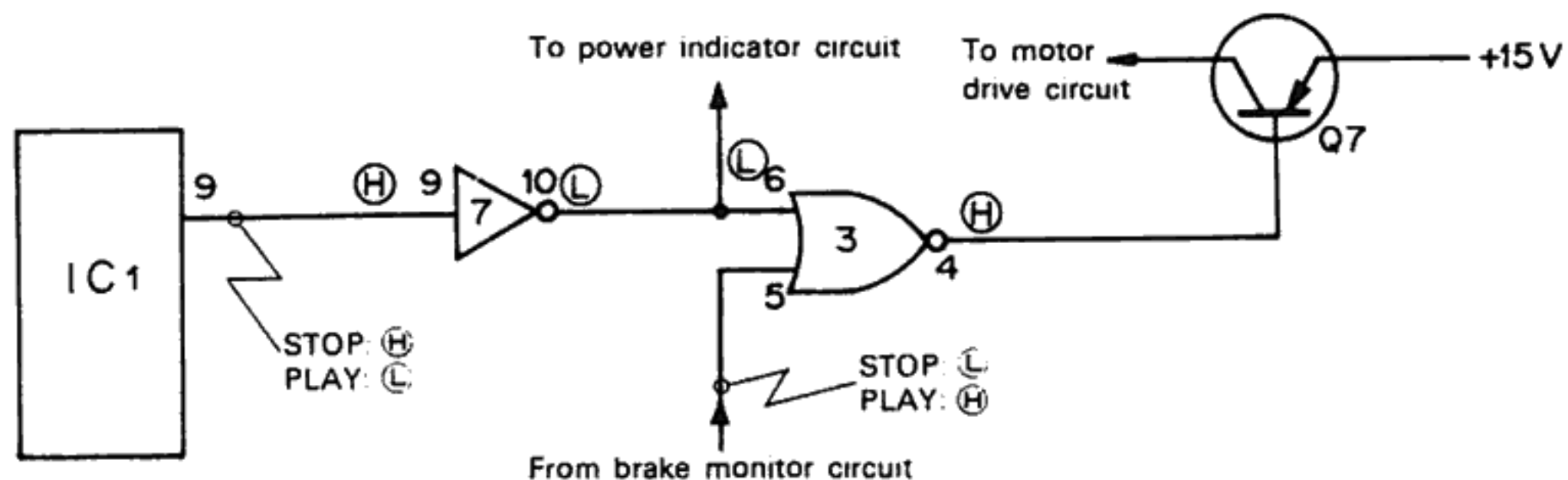

The motor drive circuit controls a +15V power supply for the 3-differential switching transistor. Control signal for switching Q7 is used as the signal generated on pin-9 of IC1 (for touch switches) and that coming from the brake monitor circuit.

In the STOP mode, for instance, pin-9 of IC1 is set to "H", bringing pin-6 of IC3 into "L". Pin-5 of IC3 accepts an "L"

level signal from the brake monitor circuit, and its output pin-4 goes "H", causing switching transistor Q7 to turn OFF. In the PLAY mode, pin-9 of IC1 is set to "L", which is inverted through IC7 and an "H" level is applied to pin-6 of IC3. Pin-5 of IC3 accepts an "L" level signal from the brake monitor circuit, and its output pin-4 goes "L", causing transistor Q7 to turn ON.

CIRCUIT DESCRIPTION

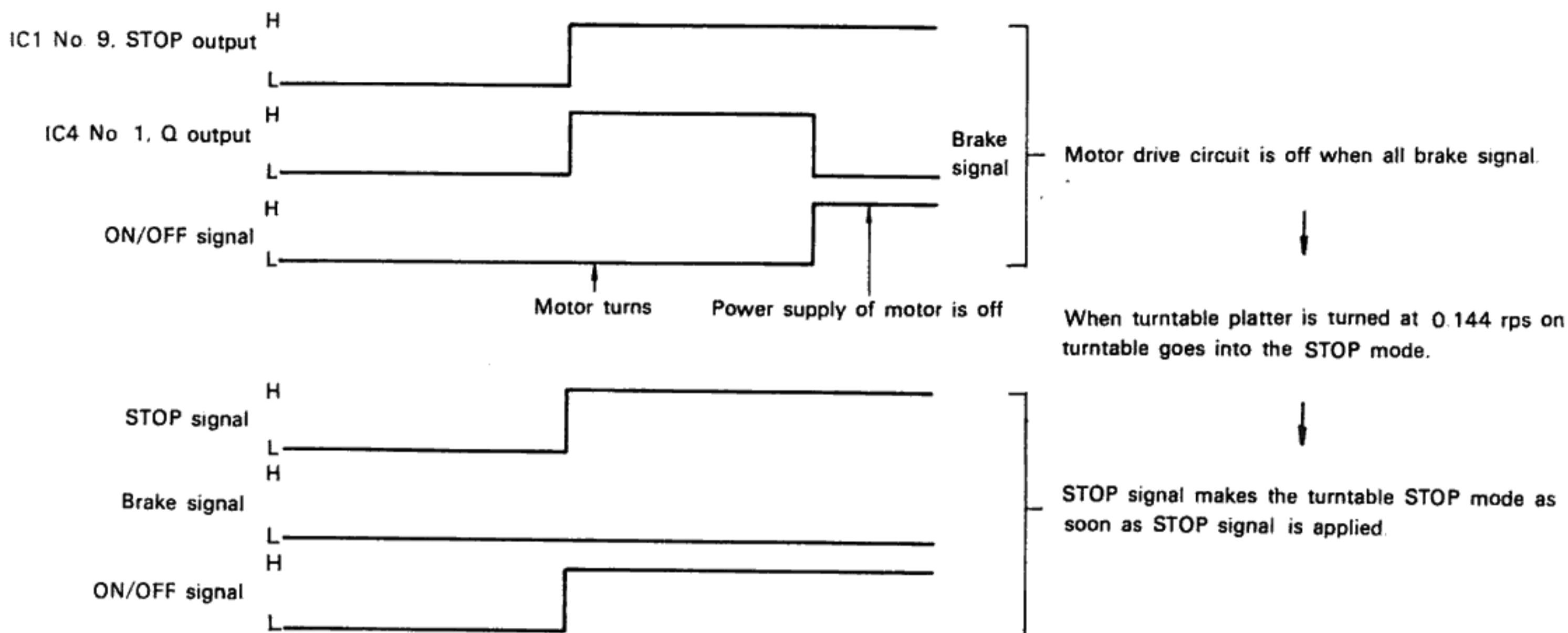

TURNING DIRECTION MONITORING CIRCUIT

The output waveform of turning direction detecting transistors Q12 through Q14 has gentle leading and trailing edges which are not adequate for a clock input for flip-flops. Therefore, those outputs are coupled to a Schmitt inverter for waveform shaping before applied to the J-K flip-flop. The signal applied to the J-K flip-flop makes its output Q "L" and \bar{Q} "H" in the normal rotation.

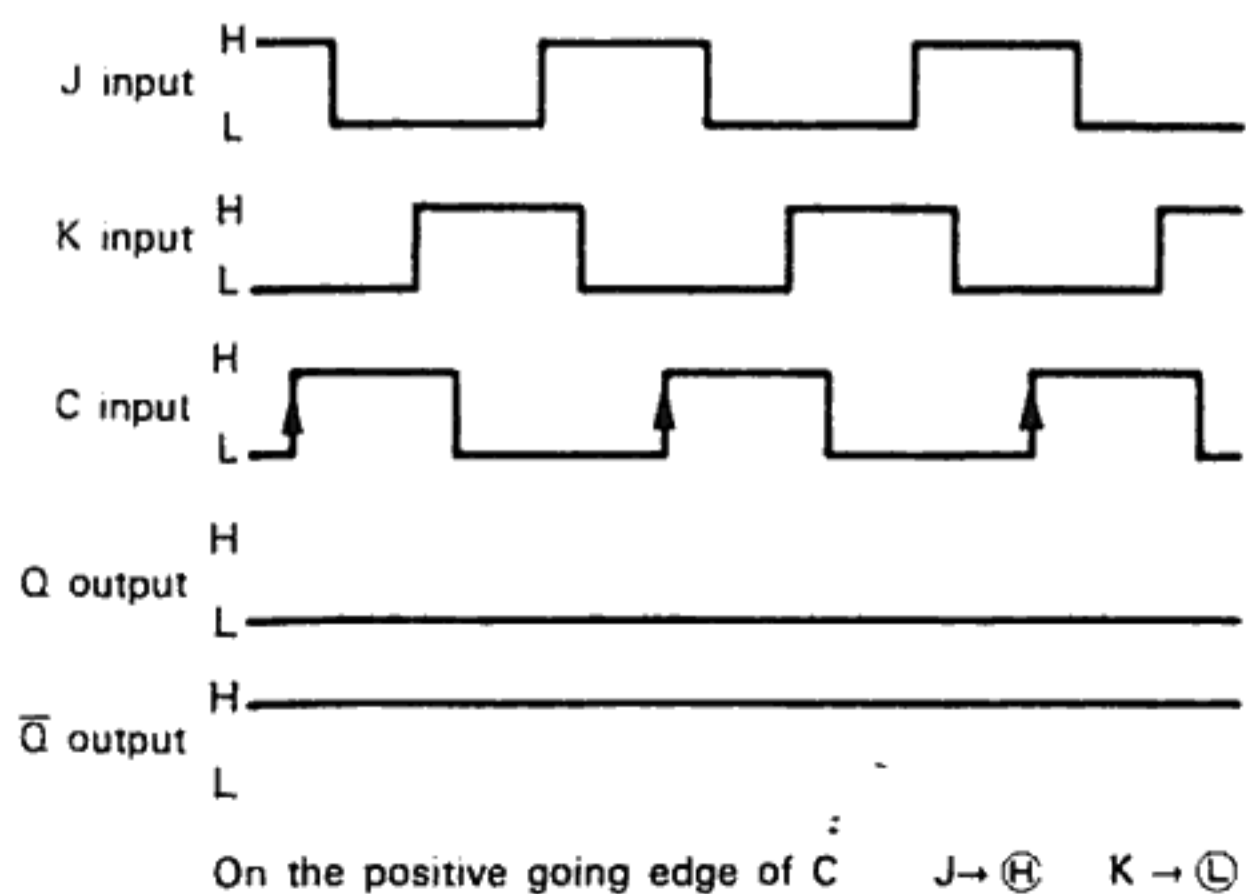
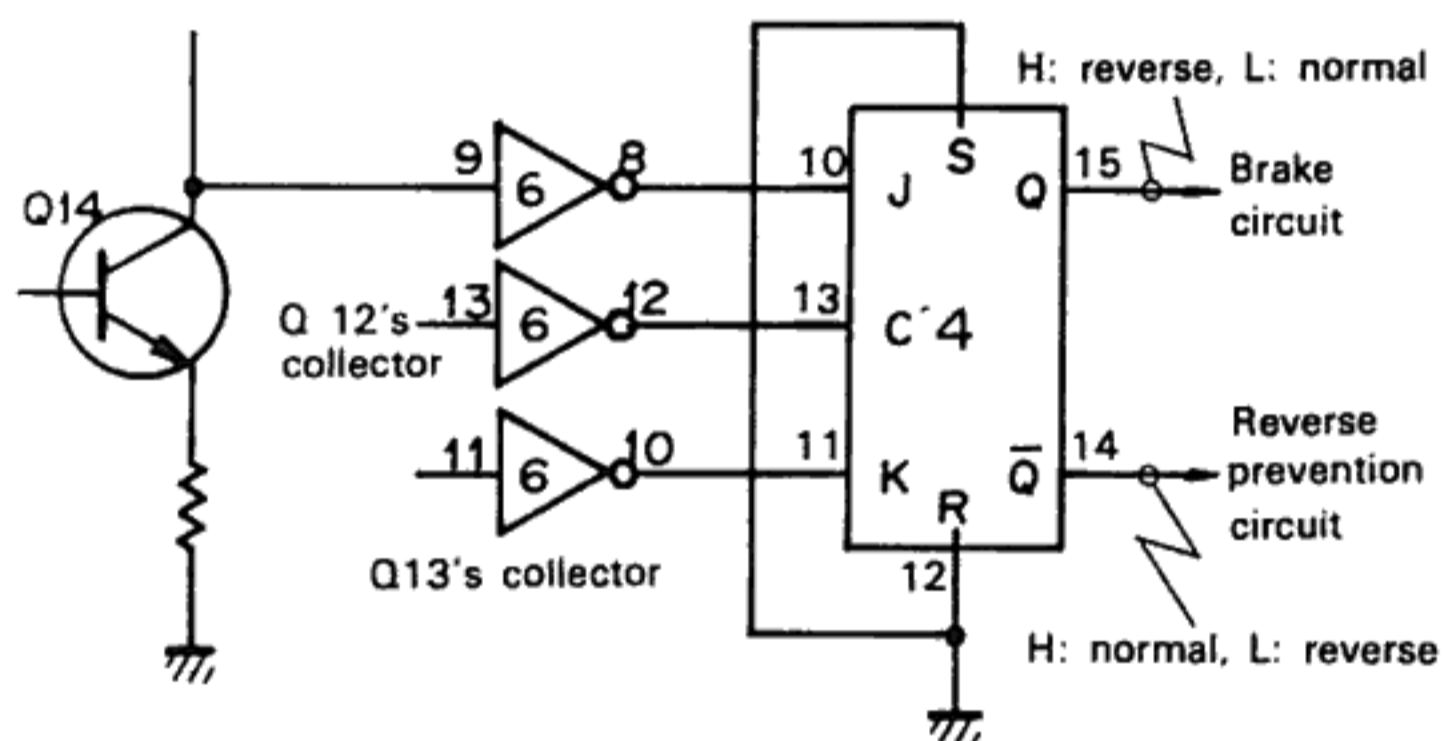

< For normal rotation >

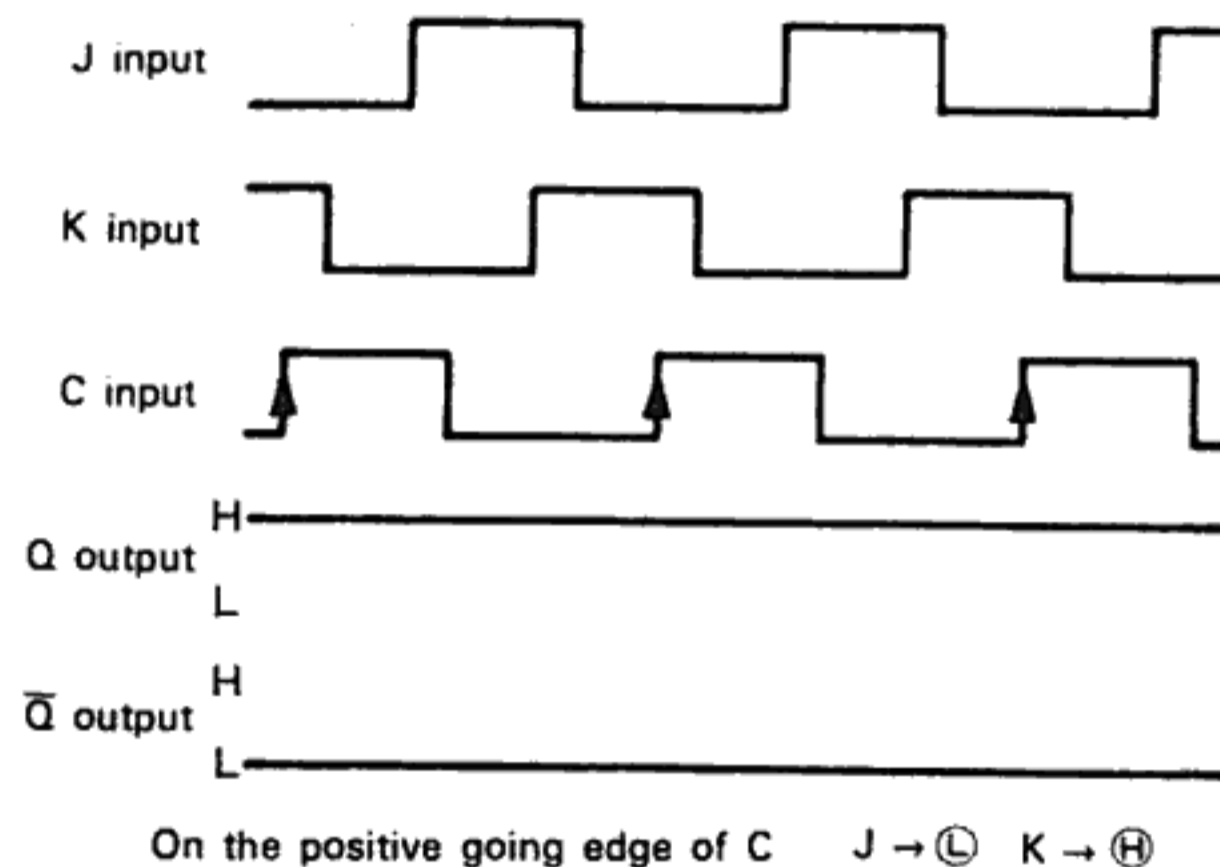

< For reverse rotation >

REVERSAL PREVENTION CIRCUIT

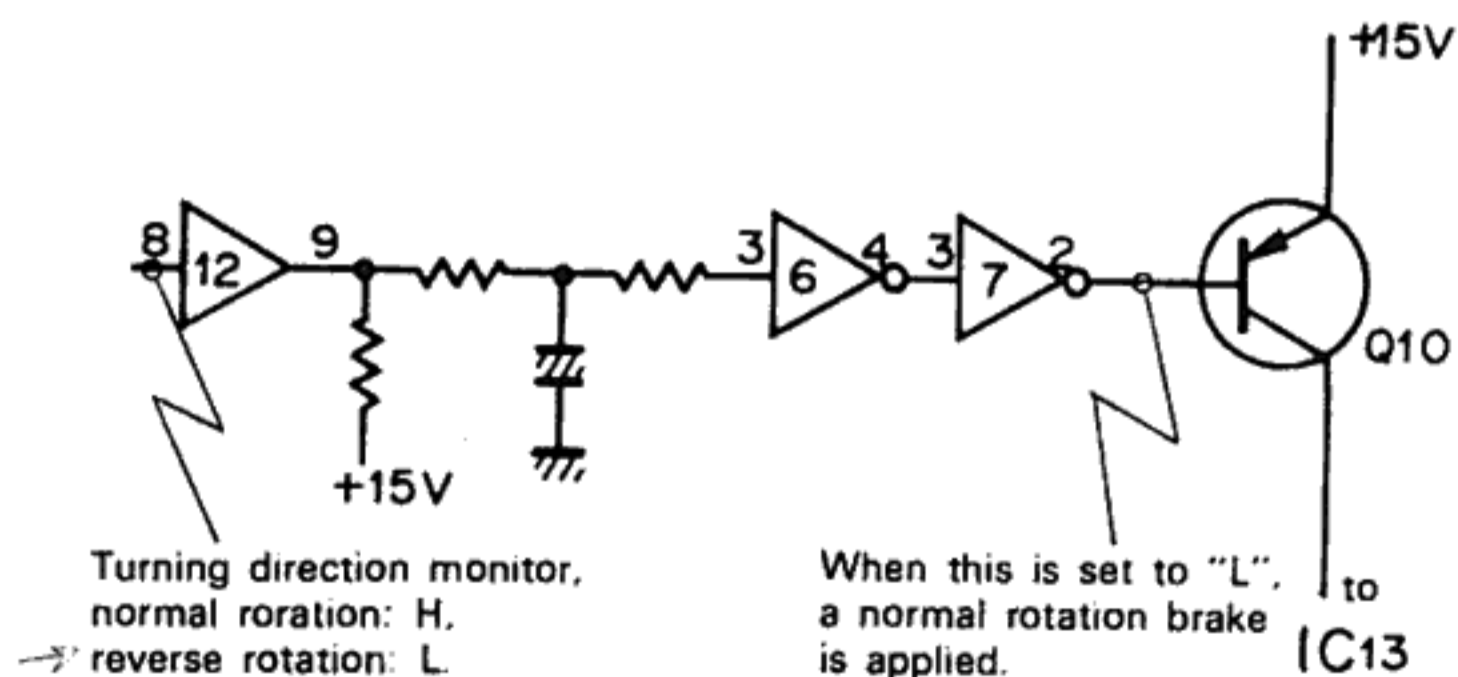

In the normal rotation, input, pin-8 of IC12, accepts "H" level, bringing the base of Q10 into "H". When Q10 remains OFF with its base pulled up to an "H" level, no voltage change occurs on input pin-3 of IC13.

In the reverse rotation, input pin-8 of IC12 accepts an "L" level signal, causing the base of Q10 to go "L". This causes Q10 to turn ON, causing input pin-3 of IC13 to go "H". This "H" level signal couples to the zero cross comparator which issues a normal rotation signal to cause a brake to the reverse rotation.

CIRCUIT DESCRIPTION

TURNING DIRECTION SELECTING CIRCUIT

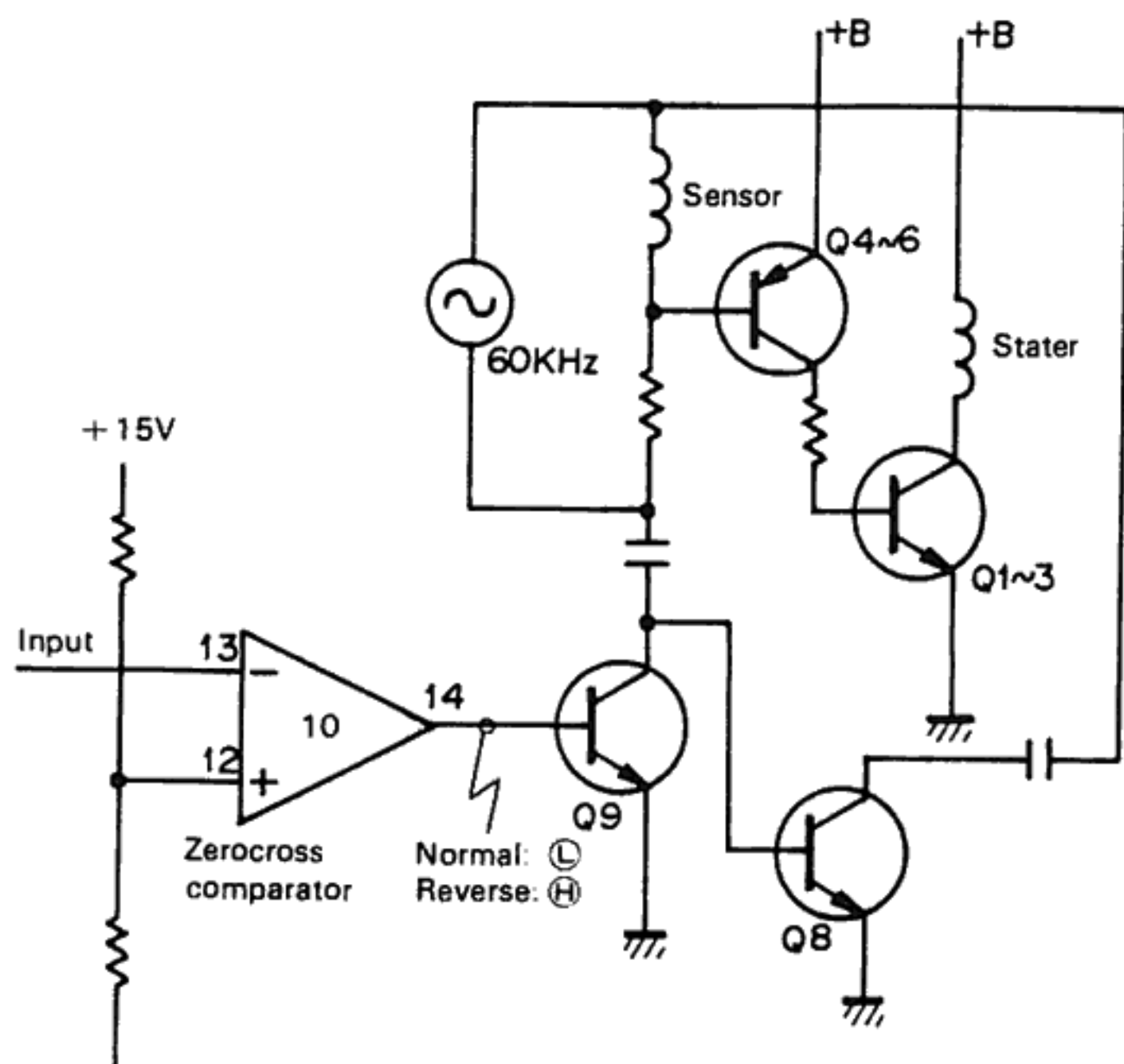

The KD-600 (650) uses transistors for turning direction selecting circuit, while the KD-750 used an IC for the circuit. The circuit operation is identical for the both cases. When an error voltage is generated on the output pin-6 of error amplifier IC13, it is coupled to an absolute-value amplifier which feeds a bias voltage proportional to the absolute value of the input voltage to position detecting transistors Q4 through Q6. The output of these transistors are coupled to motor drive transistors Q1 through Q3 which supply driving current to the motor stator.

Meanwhile, the output of error amplifier IC13 is also applied to the zero-crossing comparator which detects the turning direction of the motor.

For instance, if an excessively high voltage is applied to input pin-13 of IC10, its output pin-14 goes "L", causing Q8 to turn ON, and the motor to rotate in the normal direction. If an excessively low voltage is applied to input pin-13 of IC10, its output pin-14 goes "H", causing Q9 to turn ON, and the motor to rotate in the reverse direction.

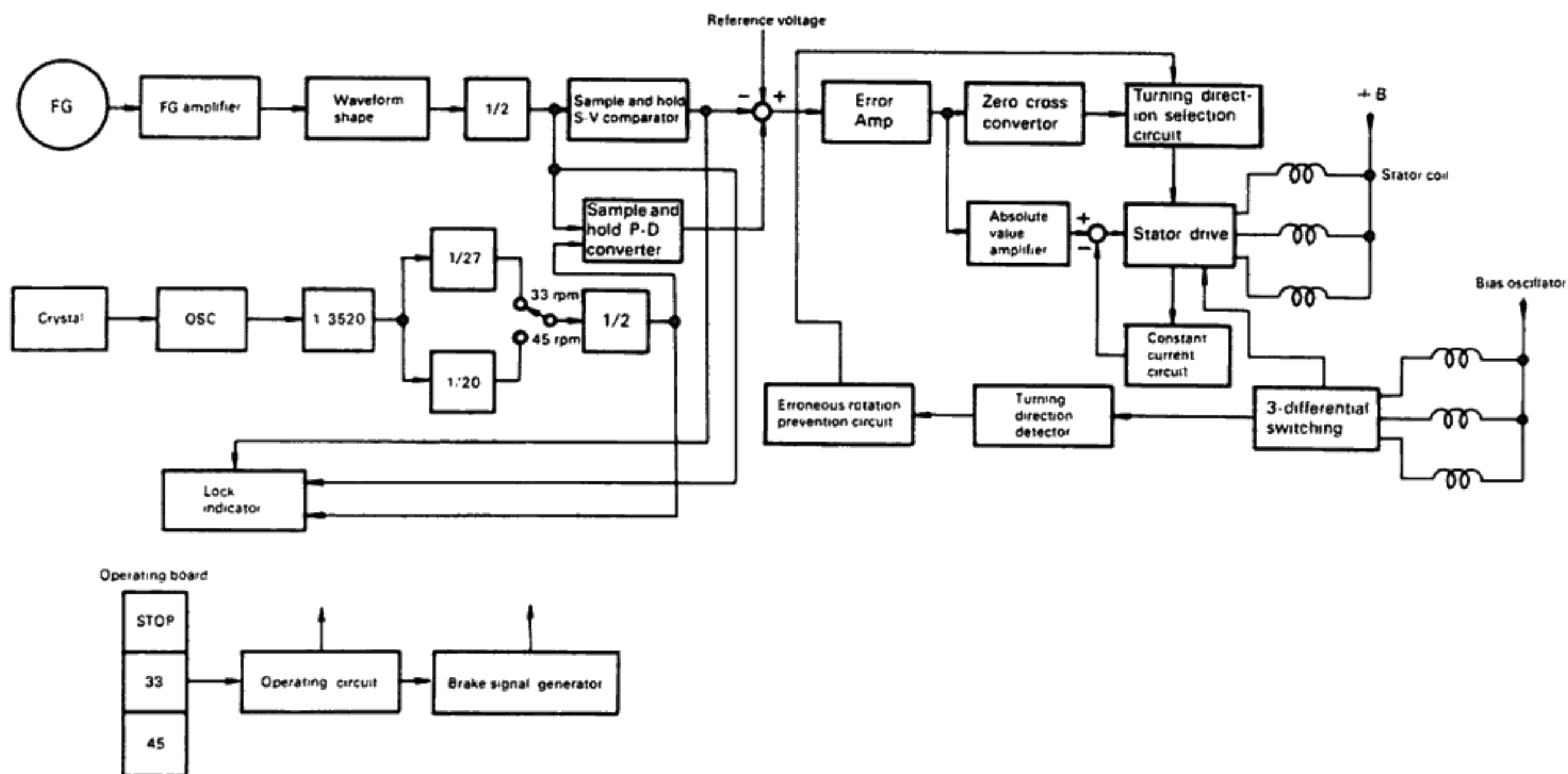

< Block diagram for PLL reversible servo >

CIRCUIT DESCRIPTION

ABSOLUTE VALUE AMPLIFIER AND CONTROL DIRECTION DETECTING SECTION

Order to perform bi-directional motor control with a single power supply, a neutral point must be provided for the control voltage. At the same time, it is required to switch the control directions above and below the neutral voltage.

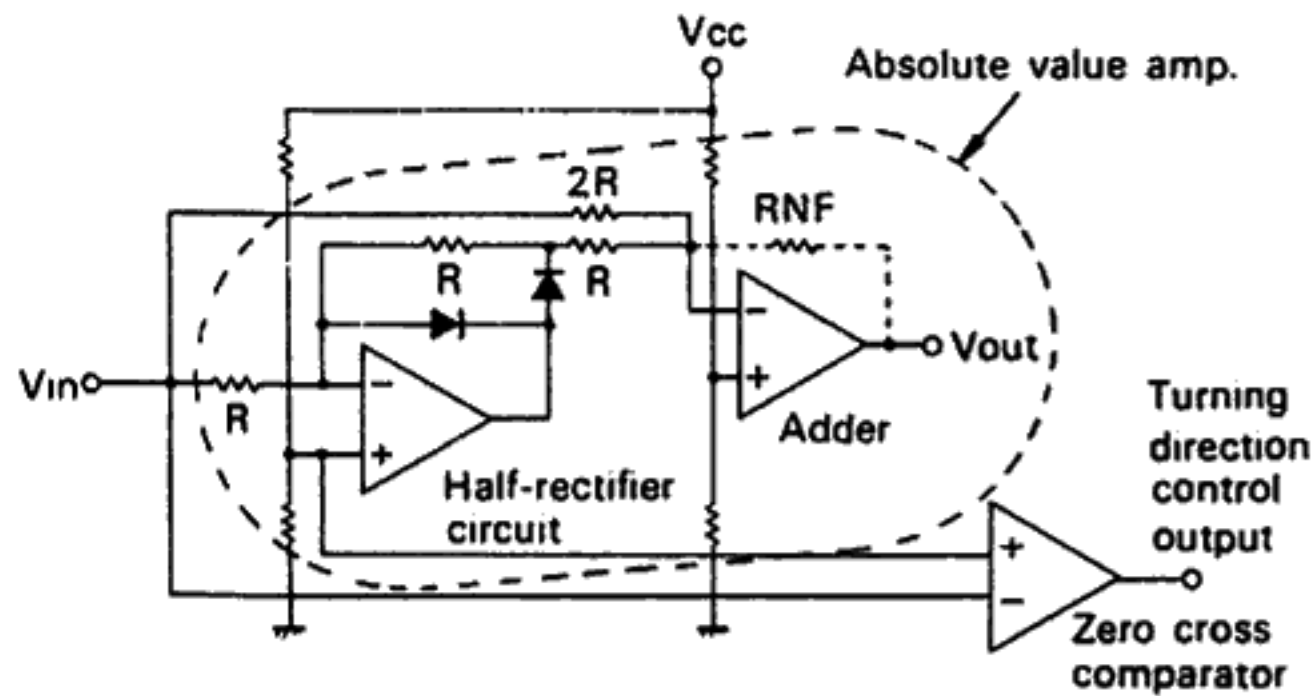

Absolute Value Amplifier and Turning Direction Detector Circuit

Above Figure shows a half-wave rectifier circuit comprised of a half-wave rectifier circuit and an adder circuit.

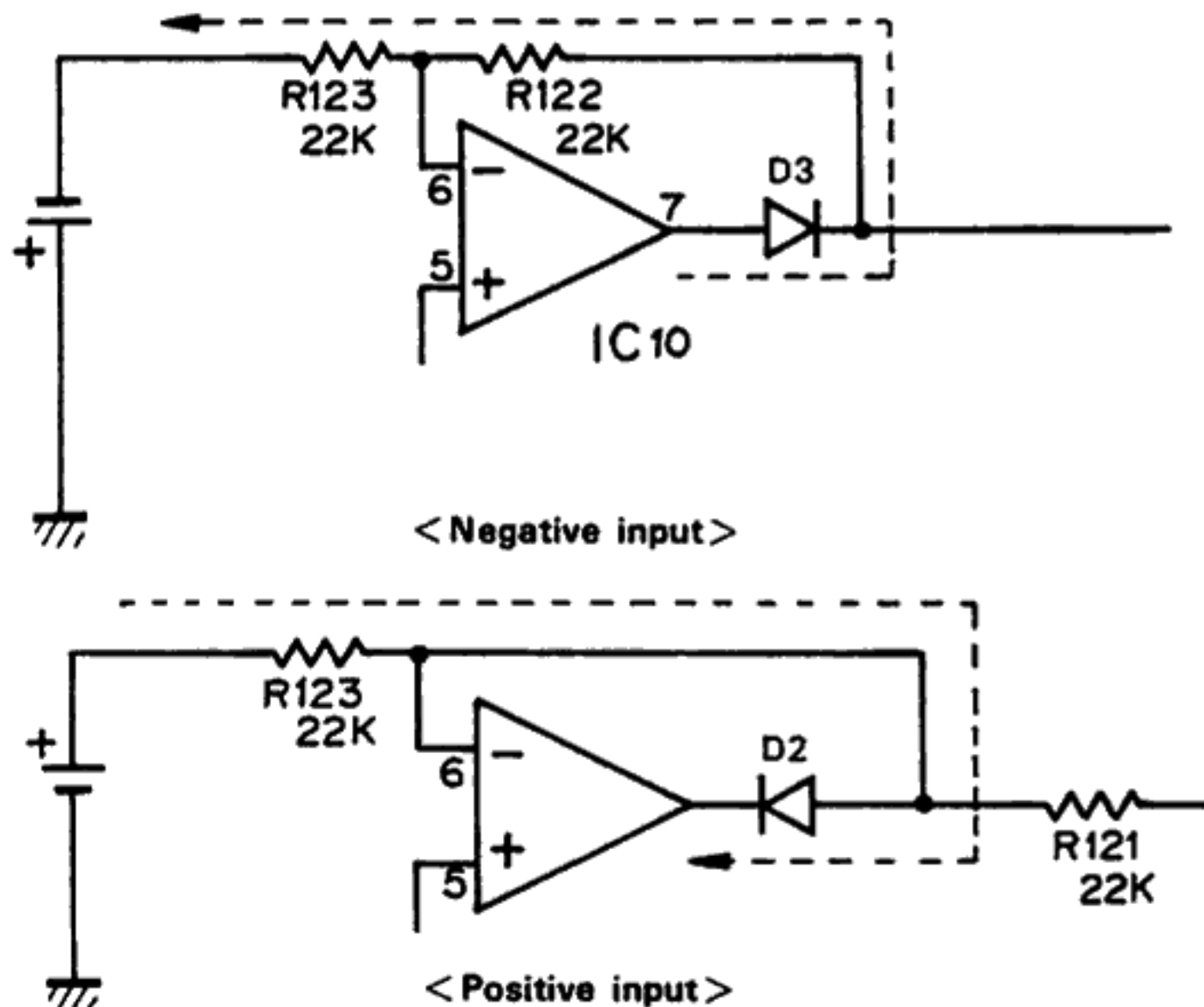

IC10 constitutes a half-wave rectifier circuit and operates as follows.

When the potential on input pin-6 goes negative with respect to the other input pin-5, IC10 operates as an inverting amplifier with unity gain because of the identical resistance of R122 and R123.

When the potential on input pin-6 is positive with respect to pin-5, diode D3 turns ON, and a reverse bias equivalent to the forward voltage of D2 and D3 is generated.

In this state, the potential of the amplifier's imaginary ground appears on the output through R122. In other words, the output potential is equal to that of pin-5 when input pin-6 is positive with respect to pin 5.

Therefore, the input-output characteristic of the amplifier is expressed as shown in the following figure.

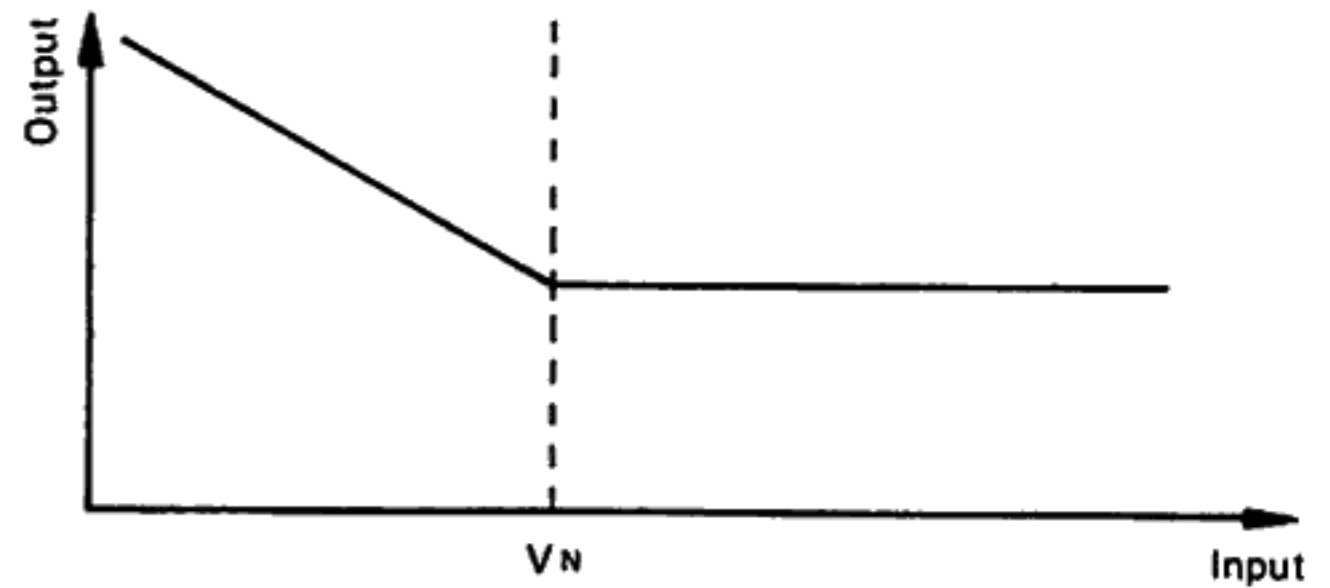

Input-output Characteristic of the Half-wave Rectifier Circuit

The output is then coupled to pin-2 of IC10 via R121. This IC10 operates as an adder circuit to add the input and output of the half-wave rectifier circuit. The adder circuit is shown in below figure.

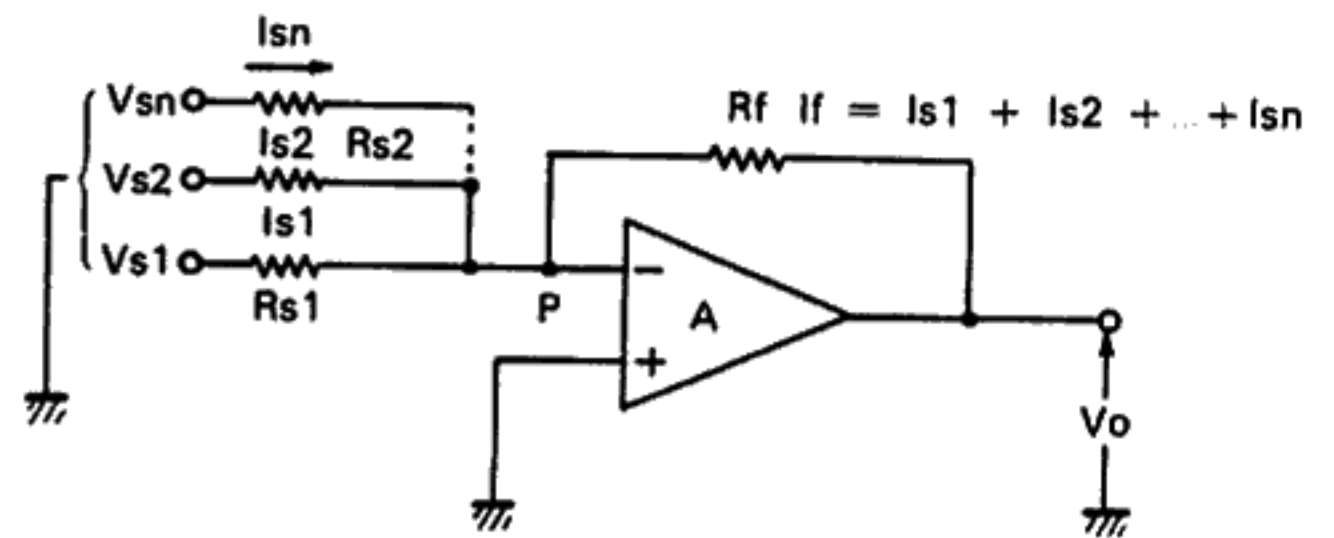

ADDER CIRCUIT

In above figure, since the current fed from point P into the amplifier is usually negligible, we obtain the following formula

$$I_f = I_{s1} + I_{s2} + \dots + I_{sn} \quad (1)$$

The potential on point P can be regarded as almost zero because the amplifier gain is very large and the non-inverting input is grounded. Therefore, each current component is expressed as follows:

$$I_{s1} = V_{s1}/R_{s1}, I_{s2} = V_{s2}/R_{s2}$$

$$I_{sn} = V_{sn}/R_{sn}, I_f = -V_o/R_f$$

Substituting eq. (2) for eq. (1) gives the following equation:

$$V_o = -R_f \left(\frac{V_{s1}}{R_{s1}} + \frac{V_{s2}}{R_{s2}} + \dots + \frac{V_{sn}}{R_{sn}} \right)$$

The above equation indicates that an output proportional to the reciprocals of $R_{s1}, R_{s2}, \dots, R_{sn}$ can be obtained. In the half wave rectifier circuit, input resistance R120 is 68K-ohms, and output resistance R121 is 22K-ohms. Therefore, the reciprocal ratio of these resistors is 1 : 3, which is illustrated as below figure.

CIRCUIT DESCRIPTION

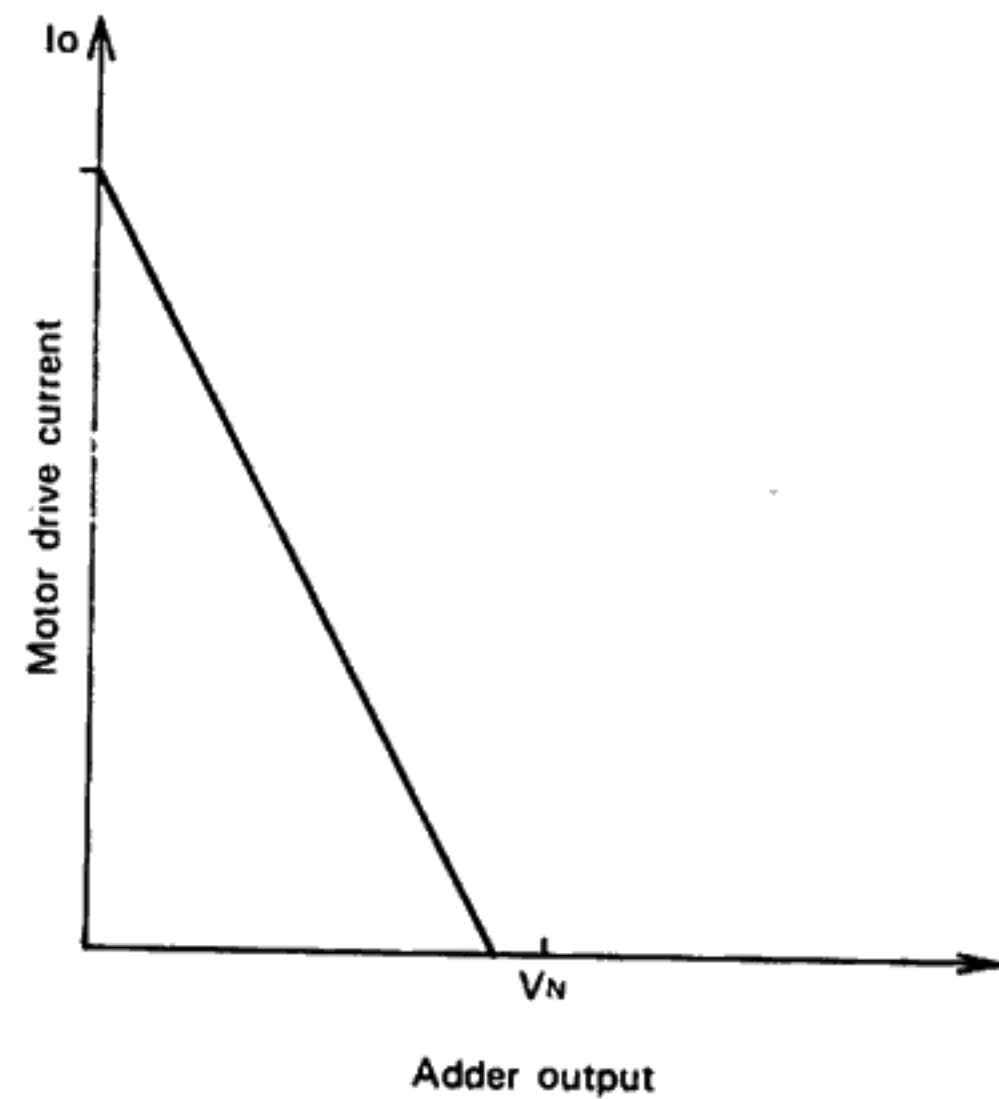
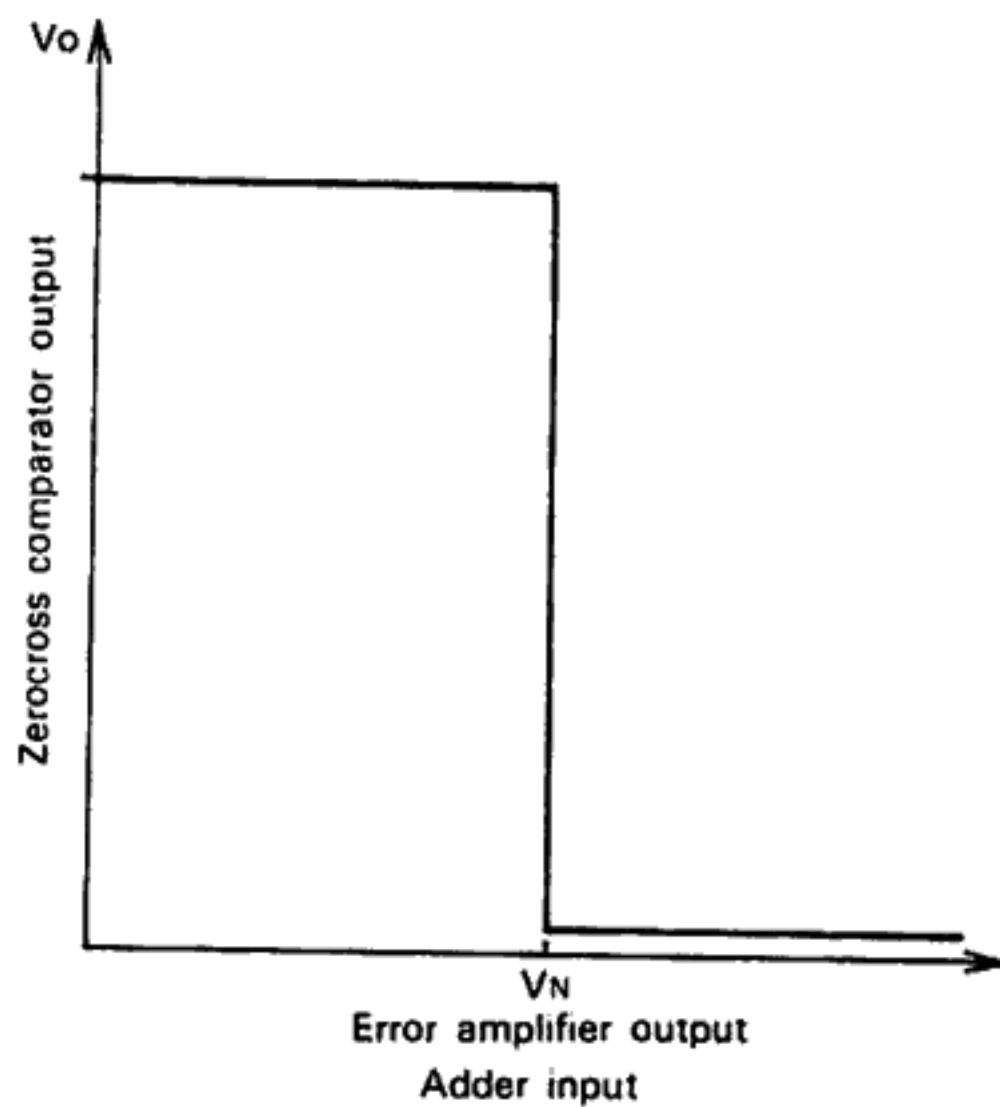
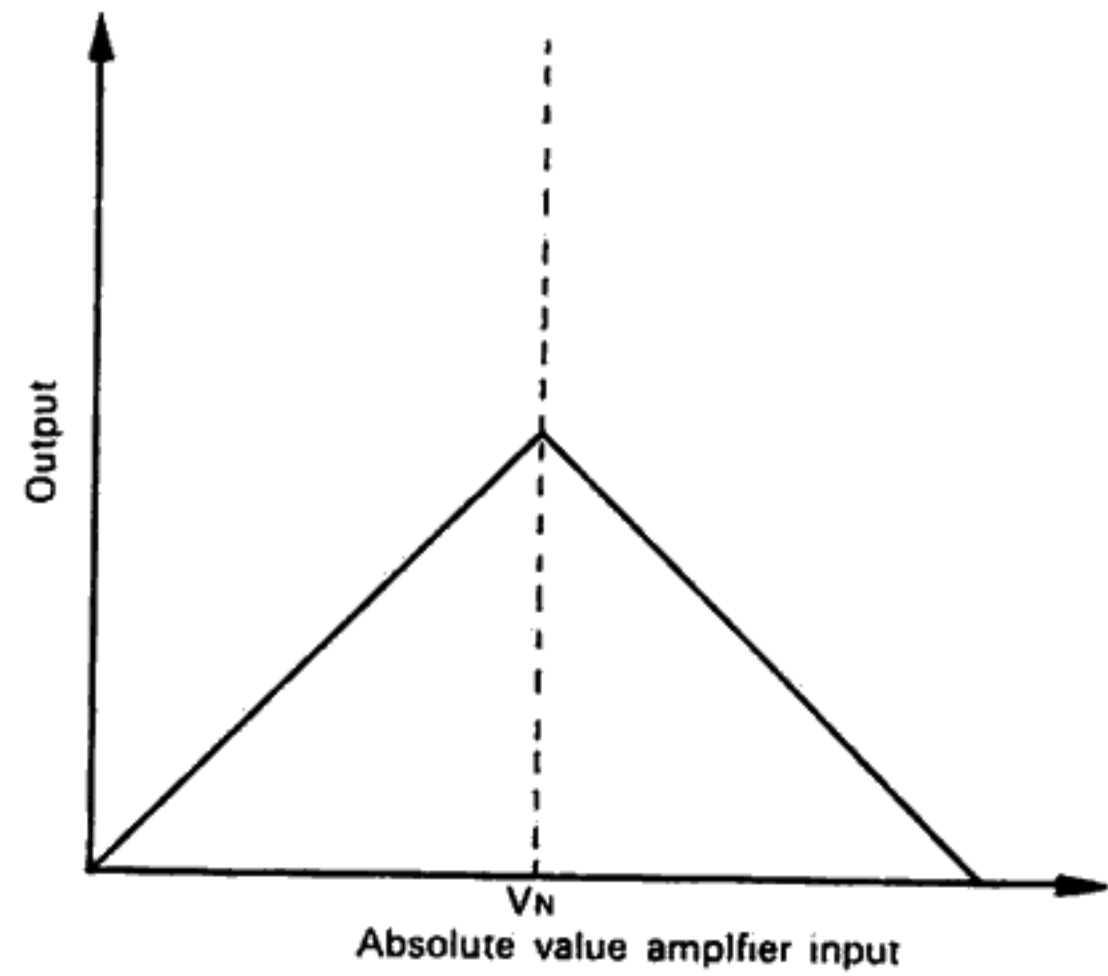
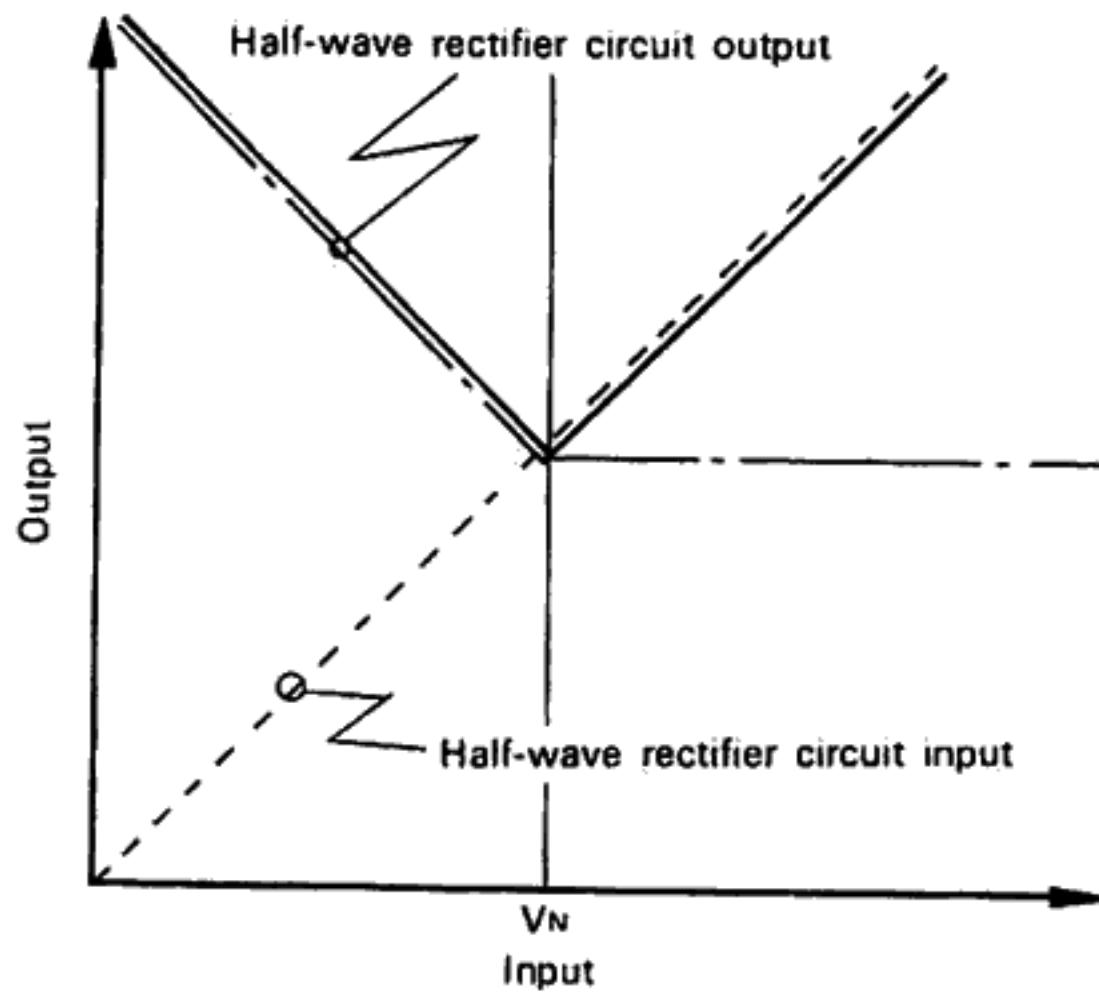

We have looked into the individual circuit operations of the KD-600 (650) turntable. Now let us discuss the overall operation of the turntable by following the signal flow.

STOP MODE

When the power of the turntable is turned ON, the initializing circuit in IC1 puts the turntable into the STOP mode. Also, voltages appear on pins 5 and 9 of IC1. The voltage appearing on pin-9 is used to control the logic circuits, and that appearing on pins 5 is used to drive the lock indicator and to change the PLL reference voltage respectively.

The "H" level output from pin-9 of IC1 goes into the lock indicator circuit where it is applied to input pin-1 of IC3. The output of IC3 thus goes "L" regardless of its other input state. This output is then inverted by IC7 into "H" and coupled to input pin-8 of IC3. Output pin-10 of IC3 thus goes "L" regardless of the state of pin-9. This "L" level output of IC3 turns off transistor Q18 for lock indicator switching, leaving the lamp turned off.

Another "H" level output from IC1 goes into the brake monitor circuit (which generates a brake signal on the transition from PLAY into STOP) where it is applied to input pin-5 of IC2. The other input pin-6 of IC2 is set to "L" since the input

to 5-step level comparator IC8 is applied high voltage. Output pin-4 of IC2 goes "H", bringing the reset terminal of IC4 into "H". Meanwhile, the J and K inputs of IC4 are pulled up to "H" (+15V) and its set terminal is always "L". Therefore, the output state of IC4 is determined by its clock and reset inputs. In the STOP mode, output Q is set to "L" while \bar{Q} is set to "H". Output Q is connected to input pin-5 of IC3 located in the motor drive ON/OFF control circuit. The other input pin-6 of IC3 accepts the STOP signal from IC1 as inverted into an "L" level signal by IC7. Output pin-4 of IC3 is then set to "H", turning off motor drive ON/OFF control transistor Q7, and thus inhibiting the +15V power supply to position detecting transistors Q4 through Q6.

When the motor remains stationary, outputs 2 and 3 of IC8 are set to "L". The pin-2 output of IC8 is connected to input pin-8 of IC2 as inverted into "H" by inverter IC7. Meanwhile, the pin-3 output of IC8 is applied to input 9 of IC2, of which output pin-10 is set to "H" and connected to the lock indicator and power indicator circuits.

In the lock indicator circuit, the signal is applied to pin-9 of IC3, bringing its output 10 into "L", and thus turning OFF Q18, as mentioned previously, to inhibit the lock indicator to turn OFF. In the power indicator circuit, an "L" level signal is

CIRCUIT DESCRIPTION

applied to input pin-1 of IC2 via inverter IC7. Since the other input pin-2 of IC2 accepts an "L" level signal from the motor drive ON/OFF control circuit, output pin-3 of IC2 goes "H", thus turning Q17 ON. The power indicator lamp connected to the Q17's collector is thus turned ON.

On the contrary, Q1 is turned OFF. This lamp is used to indicate the center line for the lock indicator. IC1's outputs 5 and 6 are connected to the operational amplifier which creates the reference voltage. Detailed descriptions for this section will be given in later paragraph. The voltages from IC1's outputs 5 and 6 are used to select dividing ratio of frequency divider IC9 which divides the frequency from the master crystal oscillator by 1/27 and 1/20 for 33 rpm and 45 rpm respectively.

TRANSITION FROM STOP MODE INTO 33-1/33 rpm

When the 33 rpm touch switch is touched, a small current passes through the switch and causes a voltage to generate on pin-13 of IC1. This makes the LED indicating the "33 rpm" to light up. On the other hand, pin-9 of IC1, which has been "H" during the STOP mode, goes into "L". Similarly, pins 5 and 6 also go into "L" level. The voltages on pins 5 and 6 are applied to pin-12 of IC9 after divided by resistors and set the dividing ratio programmed in the program counter into 1/27 for 33 rpm. In the lock indicator circuit, IC3's pin-1 transits into "L" due to the transition of IC1. The other input 2 of IC3 accepts a square wave corresponding to the turntable platter rotation. Therefore, IC3's output pin-3 feeds out a square wave reverse, in its polarity, to the input square wave. This output square wave is coupled to IC3's input 8. The other input 9 of IC3 goes "L" when the motor reaches the specified turning speed. Therefore, a reversed square wave is obtained on output 10 of IC3. The output square wave from pin-10 is connected to Q18's base, turning it ON and OFF repeatedly. The lock indicator lamp goes on and off at the frequency corresponding to the switching frequency of Q18, but it appears as if continuously illuminating since the driving signal's period and level are constant. The same token can be applied to the case of 45 rpm.

In the brake monitor circuit, the "L" level signal is applied to IC2's input 5. Since the other input 6 of IC2 goes "H" when the motor reaches the specified turning speed, output 4 of IC2 goes "H" and applies to the reset terminal of IC4. When the reset terminal of IC4 is set to "H", its outputs Q and \bar{Q} are set to "L" and "H" respectively. Output Q of IC4 is coupled to IC3's input 5 in the motor drive ON/OFF control circuit. The other input 6 of IC3 accepts an "H" level signal which is supplied from IC1's pin-9 via inverter IC7. Output 4 of IC3 thus goes "L", turning transistor Q7 ON and causing a current passing through the position detecting transistors.

While the motor is turning, a signal (FG signal) corresponding to the turning speed is generated from the motor. Since the voltage of this FG signal is too low and its leading edge is too dull, it must sustain a waveform shaping

through inverter IC6 and J-K flip-flop IC5. The FG signal applied to the half clock input of the J-K FF is obtained on its output Q because its J and K inputs are pulled up to "H" and reset terminal is set to "L". The output Q of the J-K FF is coupled to the lock indicator circuit and PLL IC9.

In the lock indicator circuit, the FG signal goes to IC5 and read into the IC, and the output of IC is reset in accordance with the reset signal coming from IC9. Output \bar{Q} of IC5, which is coupled to IC3's input 2, goes "H" and "L" repeatedly according to the reset and clock inputs. In other words, output \bar{Q} feeds out a square wave which has, as mentioned previously, a constant period.

The FG signal, after coupled to IC9, branches into the S-V output and P-D output. The S-V output goes to the adder and the 5-step level comparator. By the 5-step level comparator, the S-V signal is converted into a digital signal and makes its output terminal 2 "L" and 3 and 4 "H". Since IC8's pin-3 is set to "H", output 10 of IC2 in the speed monitor circuit goes "L". This "L" level signal goes to IC9 in the lock indicator circuit and causes to blink the lock indicator lamp.

Meanwhile, IC2's output 10 is coupled to the power indicator circuit where it turns Q17 off and Q1 on. The voltage appearing on pins 5 and 6 of IC1 is used to change the reference voltage for the PLL and lock indicator. It goes "L" in the 33 rpm mode, and is coupled to IC12's inputs 2 and 6. The output voltage caused by the input 2 of IC12 is applied to IC13's input 2 and short the resistor for generating reference voltages, the reference voltage is used for the PLL. IC13's input 3 accepts error voltages from the S-V and P-D and amplifies them before feeding them out to absolute value amplifier IC10 and the comparator.

When the input voltage to IC13's input 3 defers from the reference voltage applied to input 2 of the same IC, the difference is amplified and coupled to the absolute value amplifier and comparator on the next stage.

If the difference is positive, an amplified difference voltage directly appears on IC13's output 6. The output of the absolute value amplifier turns Q4 through Q6 ON orderly, causing the motor to rotate at a higher speed.

Also, when a positive voltage is applied to the comparator's input 13, its output 14 feeds out a negative voltage, turning Q8 ON, and causing the turning direction switching circuit to go into the normal turning mode. In other words, when a voltage higher than the reference voltage is applied to IC13's input 3, the motor rotates in the normal direction at a higher speed.

Meanwhile, when a voltage lower than the reference voltage is applied to IC13's input 3, the absolute value amplifier causes the motor to turn at a speed proportional to the difference voltage regardless of the polarity of the difference voltage. On the other hand, since the polarity of the voltage applied to IC10's input 13 is reversed, a reversal force is exercised to the motor. In other words, when a voltage lower than the reference voltage is applied to IC13, a reversal signal is issued, causing a braking force to the motor.

CIRCUIT DESCRIPTION

45 rpm

Since the logic operations are based on the status difference between the STOP and PLAY modes, those for the 45 rpm are almost the same as those for the 33 rpm, except that the voltage to the comparator IC13 is different from that for the 33 rpm

TRANSITION FROM THE PLAY MODE INTO THE STOP MODE

When the STOP switch is touched, the output of IC1 goes into the STOP mode. (Refer to the description of the STOP mode) Before the motor drive circuit goes into the STOP mode, the logic circuit issues a brake signal. Input 5 of IC2 in the brake monitor circuit goes "H" immediately after the STOP switch is activated, while the other input 6 of IC2 goes "H" (This "H" level is retained until the motor rotation reaches 0.144 rps or less). IC2's output 4 and its reset terminal go "L". Since IC4's clock input accepts a positive going signal, its outputs Q and \bar{Q} reverse their states, applying a brake signal to the brake circuit. Input 12 of IC3 in the brake circuit accepts the brake signal (H \rightarrow L) from IC4's \bar{Q} . The output of the brake circuit goes "L", and is added to IC13's input 3. It is then reversed in its polarity and causes braking to the motor

REVERSAL PREVENTION

The KD-600 (650) turntable is equipped with a reversal prevention circuit. While the motor is rotating, the turning direction monitoring circuit always monitors the motor's turning direction. When the turntable platter is manually rotated in the reverse direction before put into the PLAY mode, IC4 in the turning direction monitor circuit issues a reversal signal. Output Q of IC4 is coupled to the brake circuit, and pulls up IC13's input 3 toward positive, switching the turning direction switching circuit into the normal mode and applying the normal-direction brake to the motor. When the normal rotation is restored less than 0.144 rps, the turntable platter becomes in STOP condition because of setting the reset terminal of IC4 to "H" and of turning off Q7. Output \bar{Q} is coupled to Q10 via two inverters. When the motor rotation is in the normal direction, Q10's base accepts an "H" level output from \bar{Q} , and Q10 turns OFF. Therefore, no normal turning signal is issued. When the motor rotation is in the reverse direction, output \bar{Q} goes "L", turning Q10 ON. IC13's input 3 then goes "H", bringing comparator IC10's output 14 into "H". This causes a normal turning brake to restore the motor rotation into the normal direction.

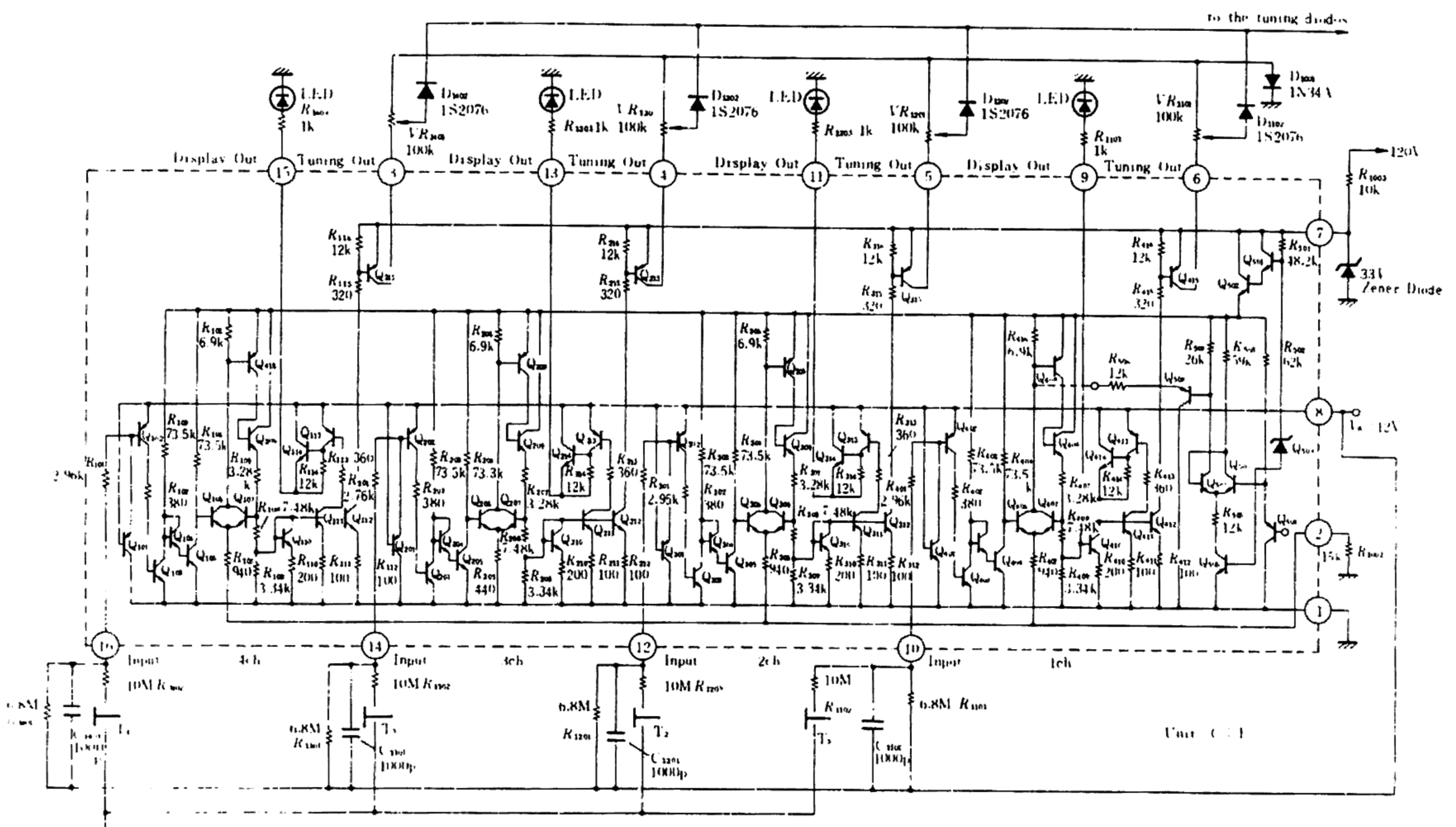

from "HITACHI LINEAR IC'S FOR ACOUSTIC EQUIPMENT"

< SAS560S Internal Schematic Diagram >

DISASSEMBLY FOR REPAIR

This disassembly procedure is for KD650.

Before disassembly, remove the screws fixing the bottom board.

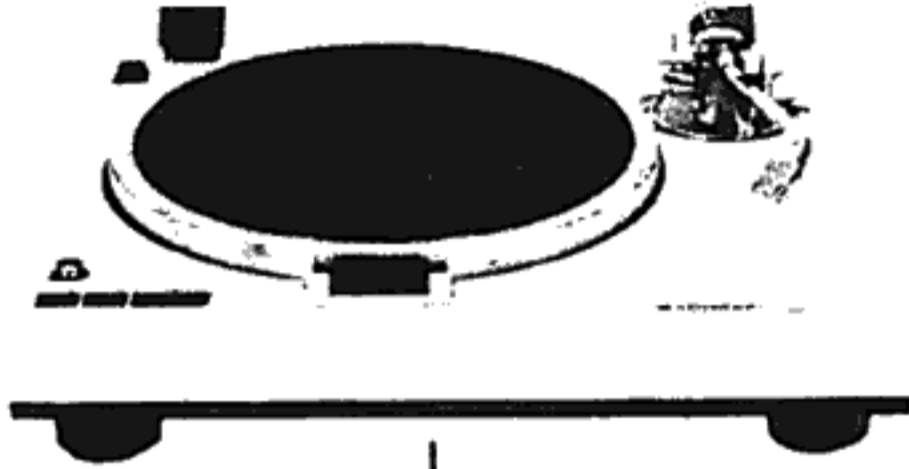

Shield Plate

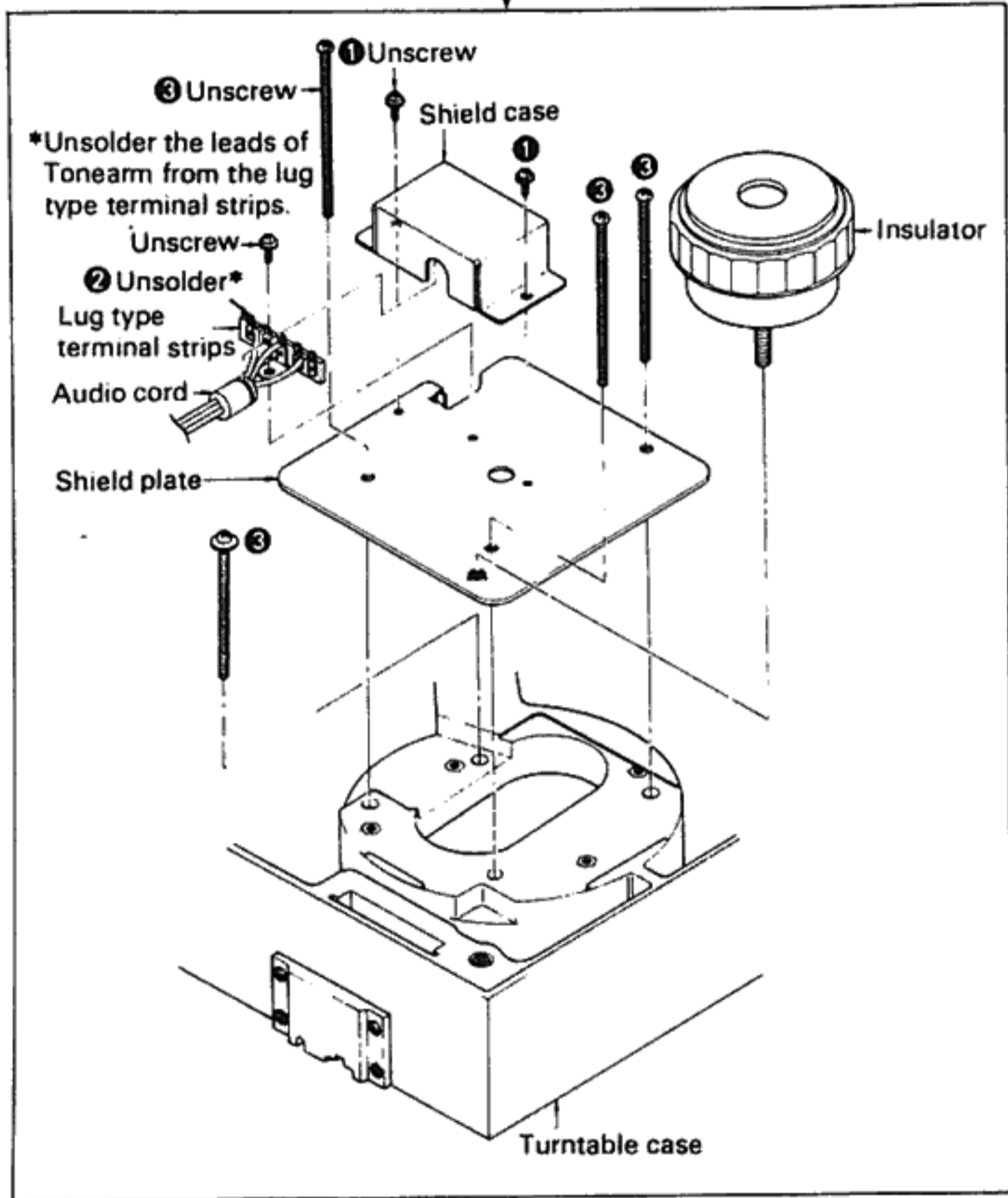

Tonearm Ass'y

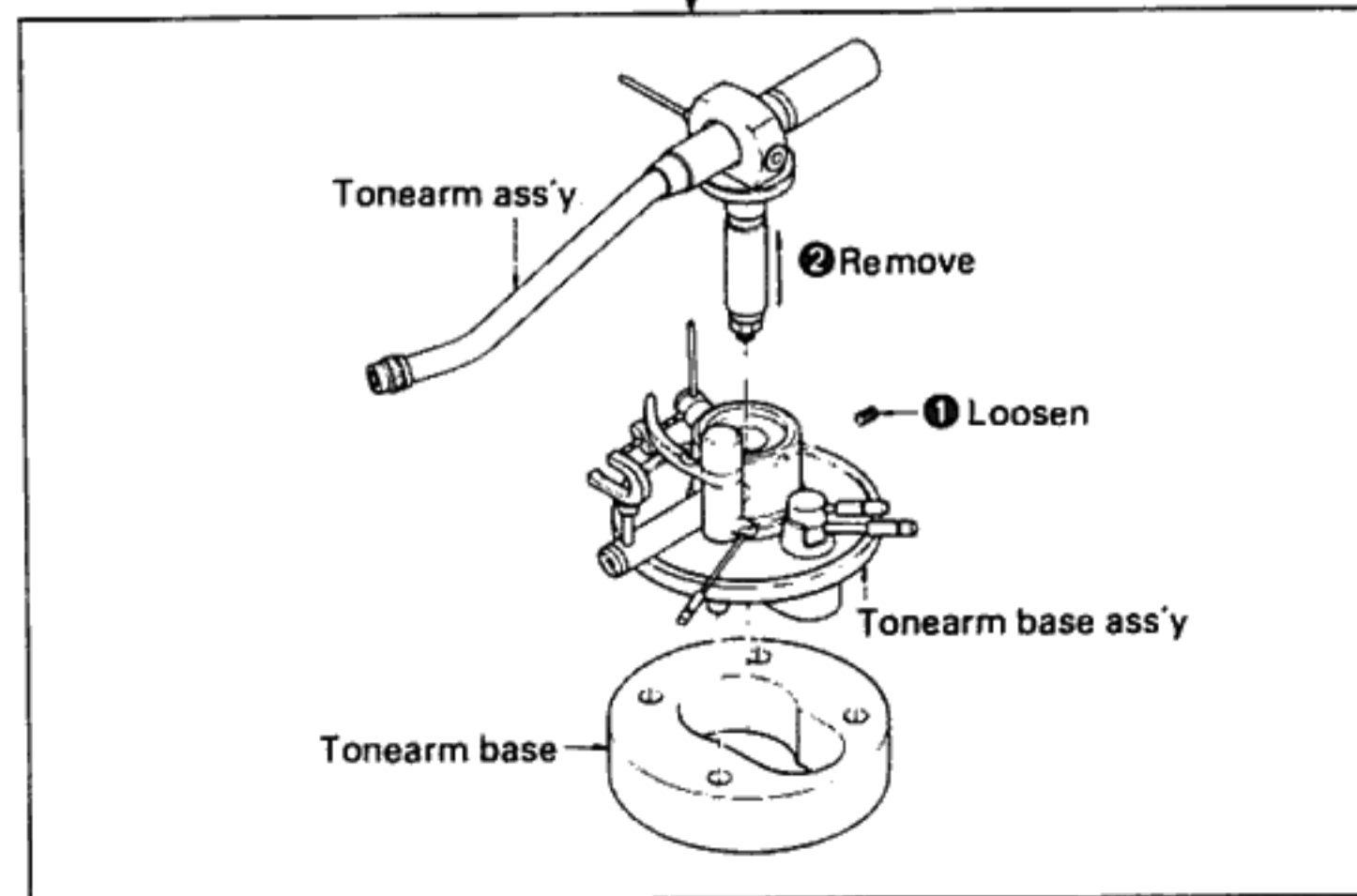

Switch

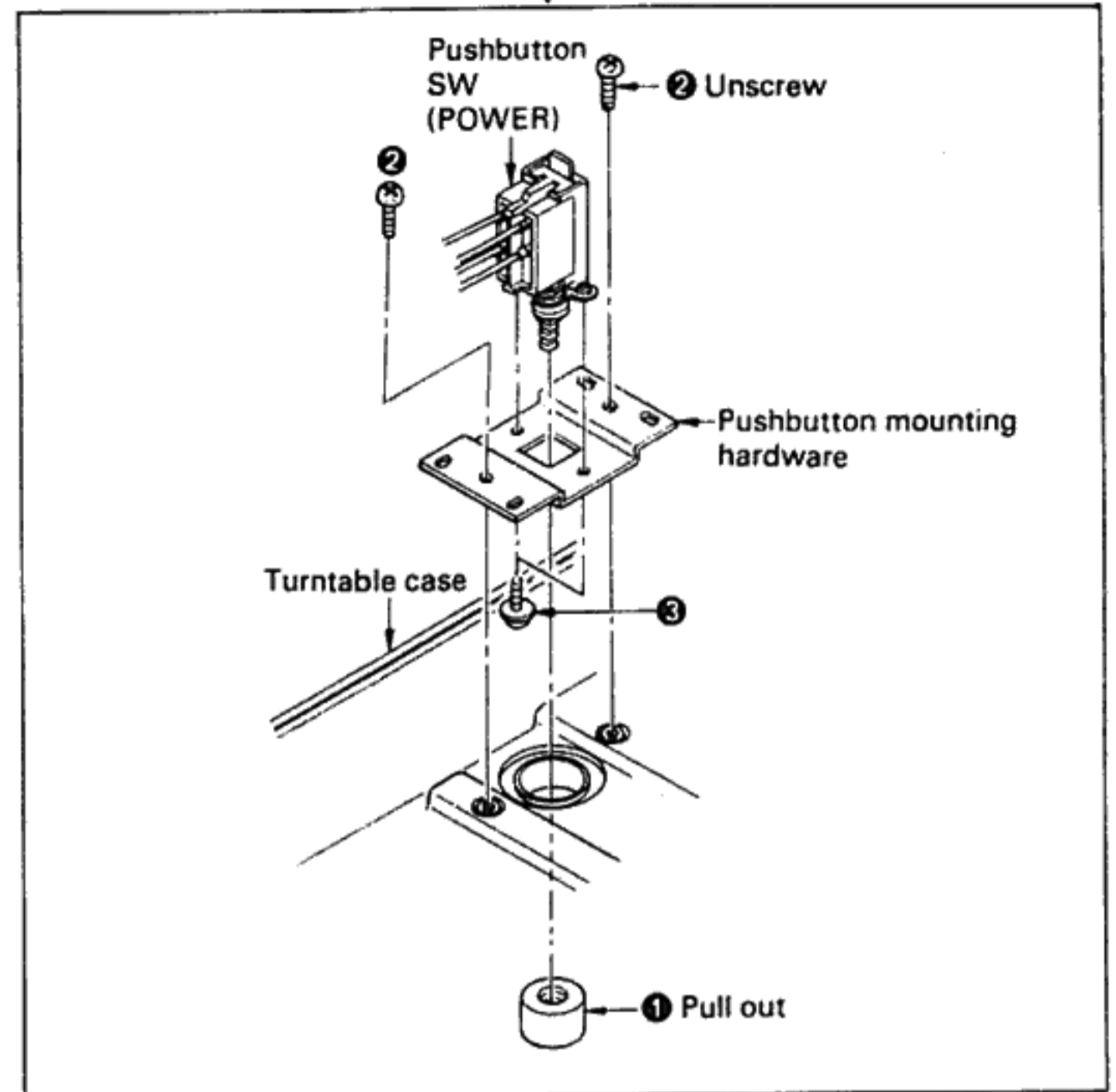

Slide Shaft Ass'y

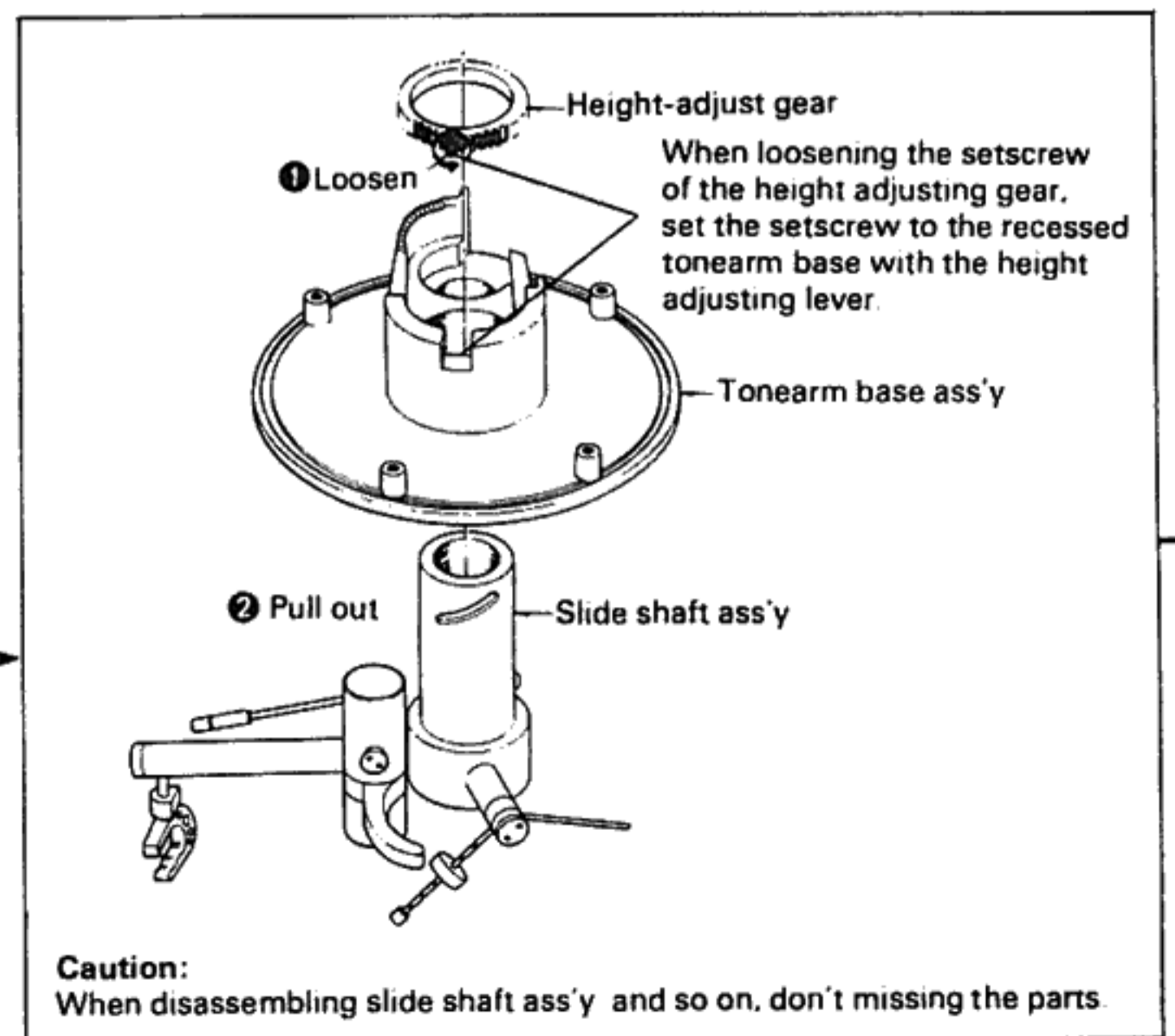

BLOCK DIAGRAM

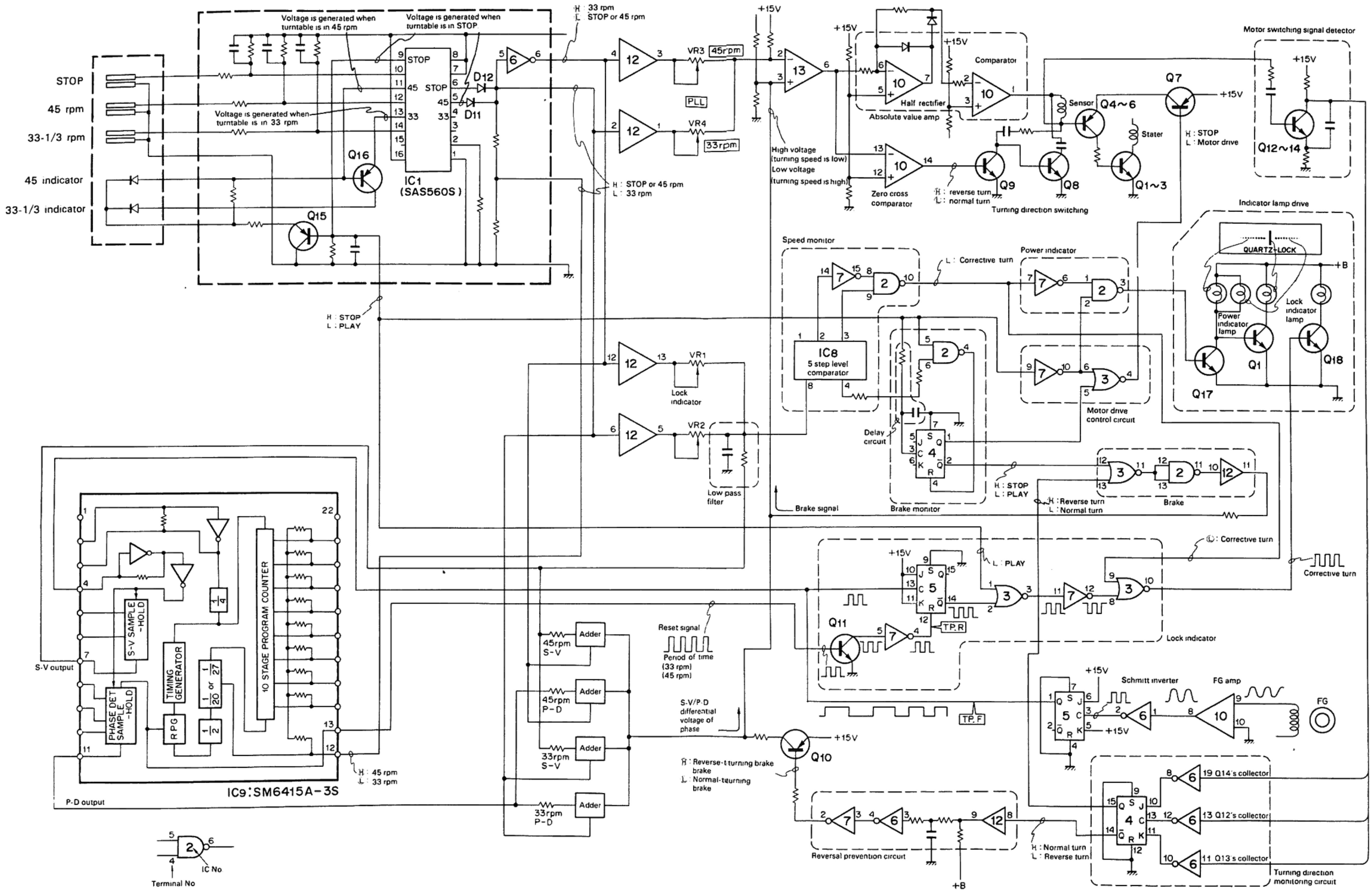

MECHANISM

ASSEMBLING THE TONE ARM UNIT

- 1 Insert the slide shaft ass'y (hereinafter referred to as "slide shaft") into the arm base.
- 2 Align the curve of the fixing cam with the edge of the slide shaft.

Note:

The slanted section of the fixing cam should be positioned as shown in the illustration below

- 3 With the adjust bolt fitted in place, engage the slide cam with the fixing cam

Note:

Screw the adjust bolt into the slide cam so that the slanted section of the slide cam is engaged with the fixing cam.

- 4 Mount the fixing lever
- 5 With the fixing lever set in full UP position, secure the lever making sure that the adjust-bolt setscrew is in the UP position.

Note:

The fixing lever should be locked securely at the center position.

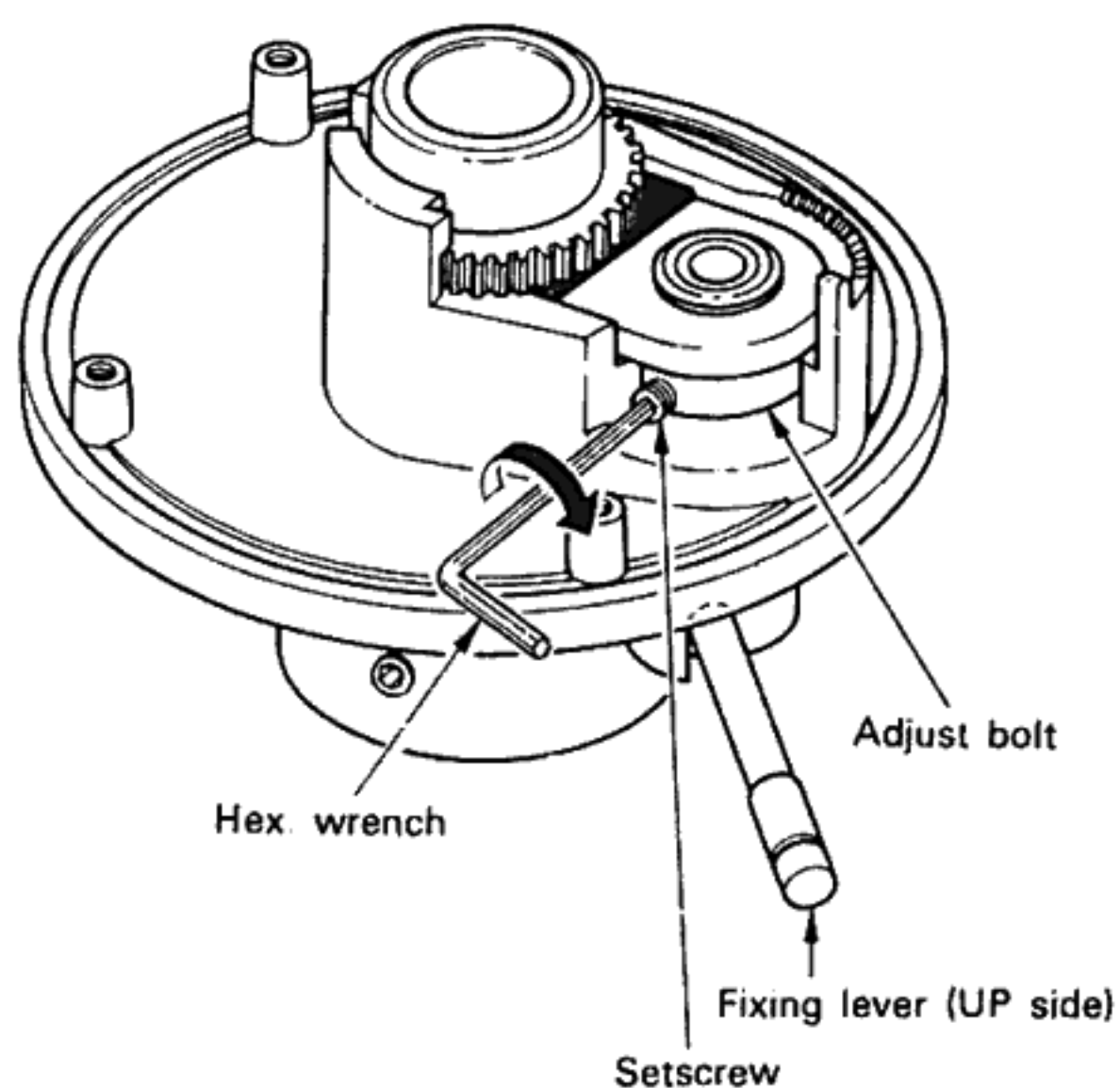

< Positions of Fixing Lever and Adjust Bolt >

- 6 Loosen the fixing lever in the UP direction and lower the slide shaft until the height-adjust gear is fitted in place. Insure that the setscrew of the height-adjust gear is positioned in the notch of the arm base.
- 7 Tighten the setscrew while making sure that it is fitted in the groove of the slide shaft

Note:

Do not tighten the setscrew excessively, as it will cause the slide shaft to fail to move up and down. After tightening the screw, loosen it about one turn. This screw should be locked with adhesive cement

8. Lower the slide shaft to the extreme DOWN position. Then set the height-adjust can ass'y as illustrated below. Secure the height-adjust lever

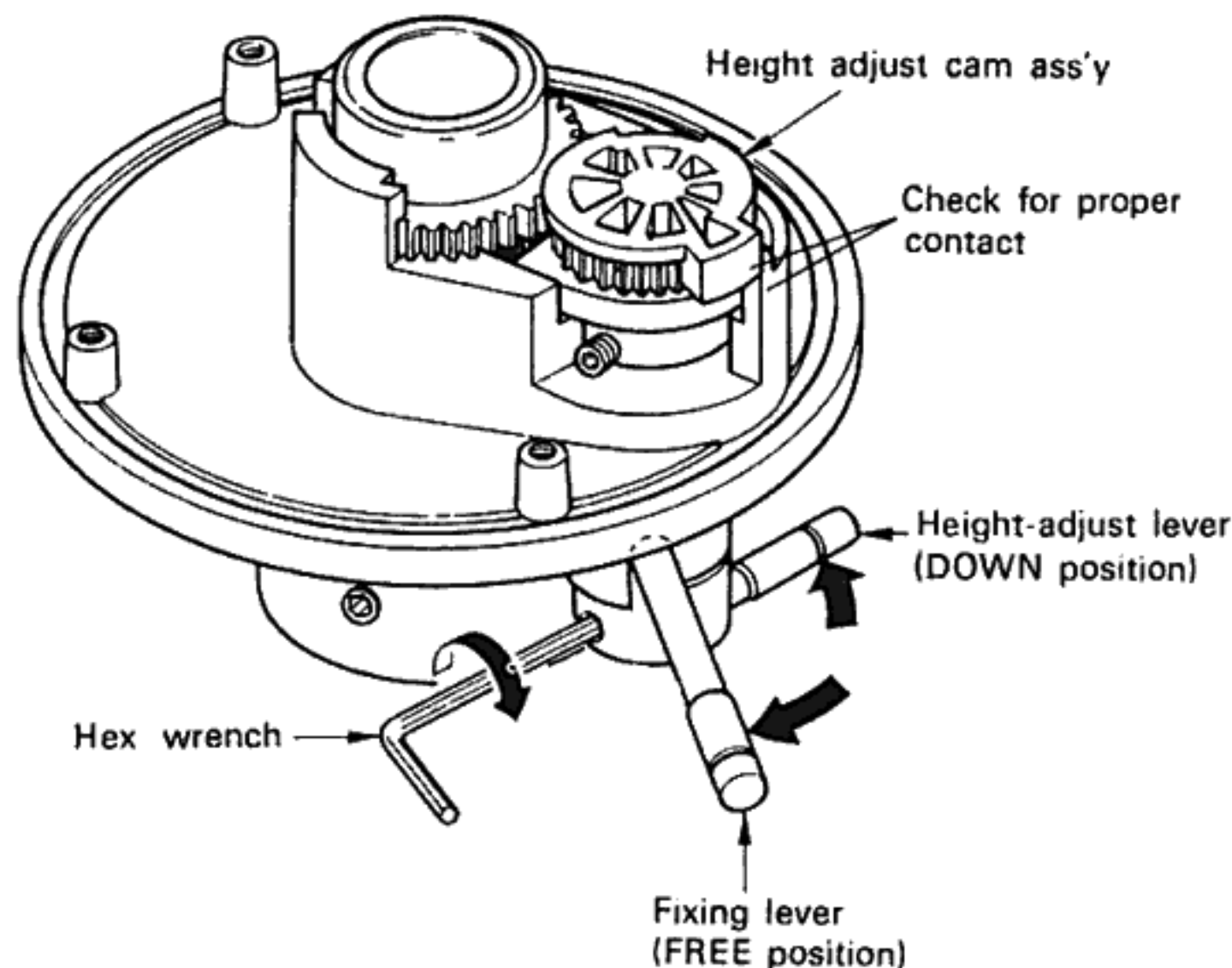

< Positions of Height-Adjust Lever and Cam >

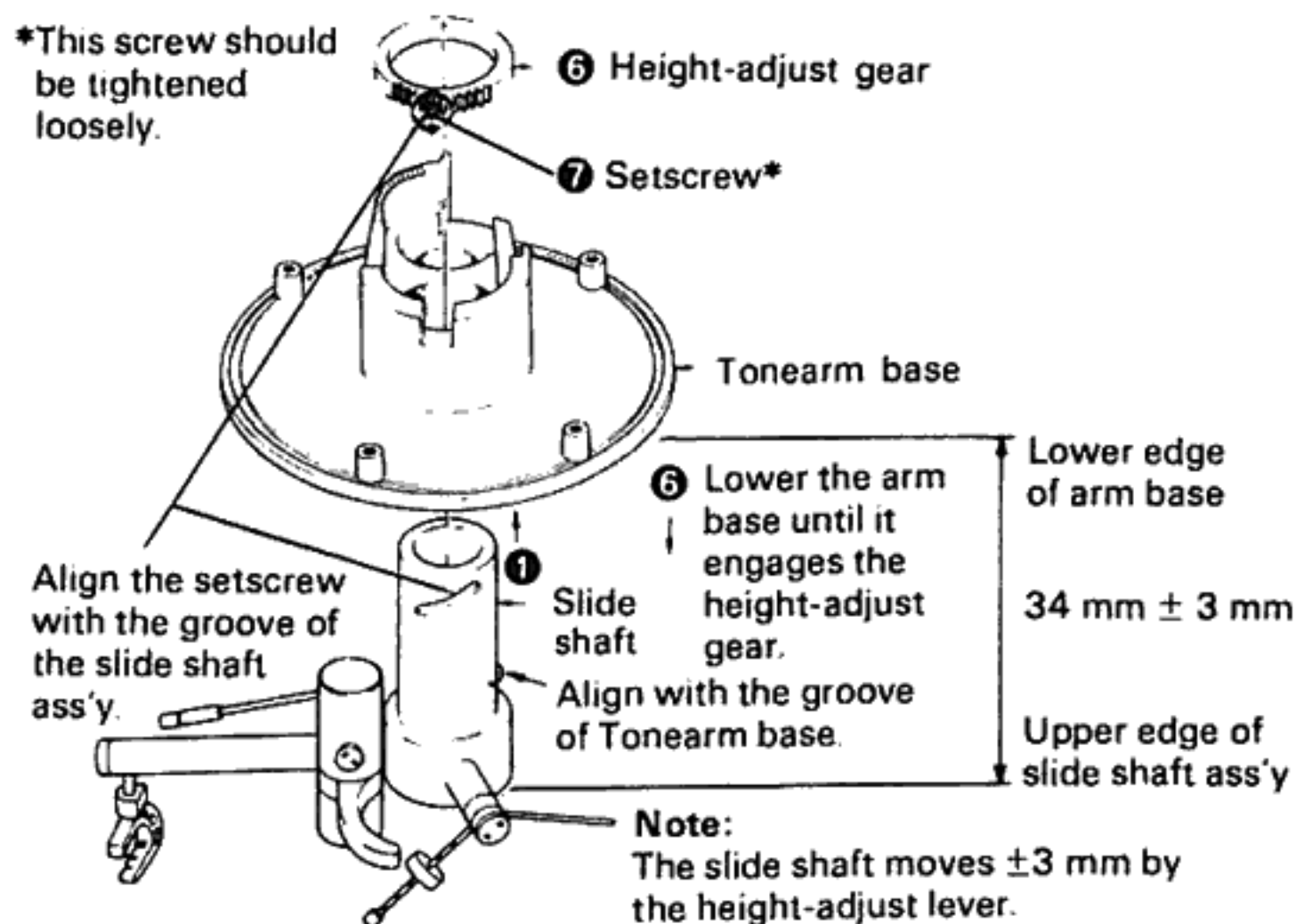
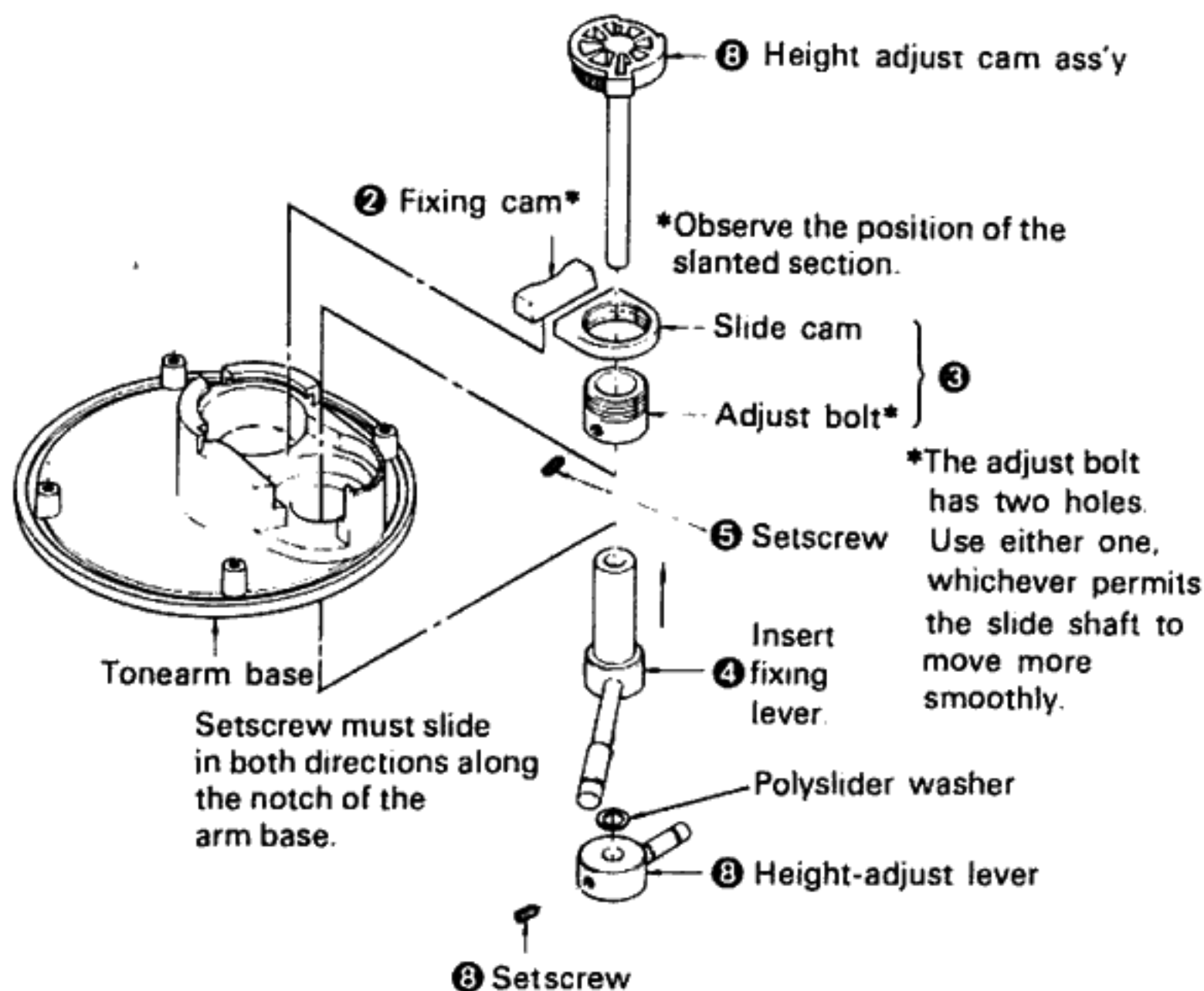

< Assembly of Tonearm >

DISASSEMBLY FOR REPAIR

This disassembly procedure is for KD650.

Before disassembly, remove the screws fixing the bottom board.

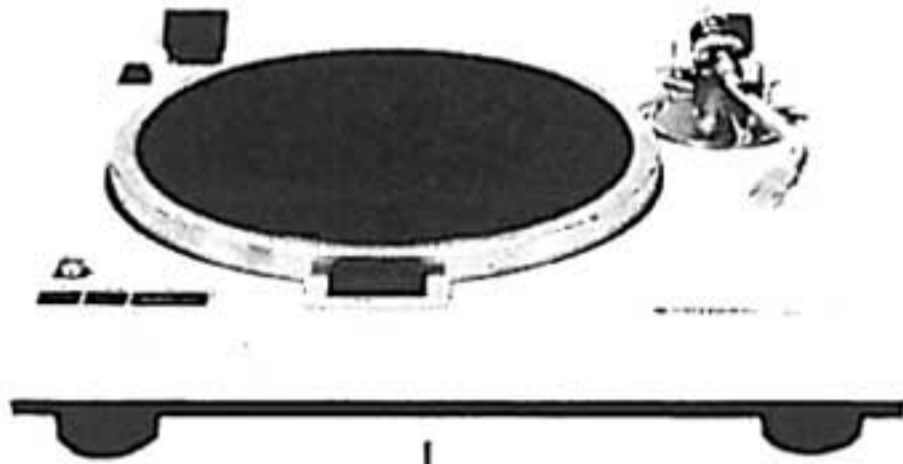

Shield Plate

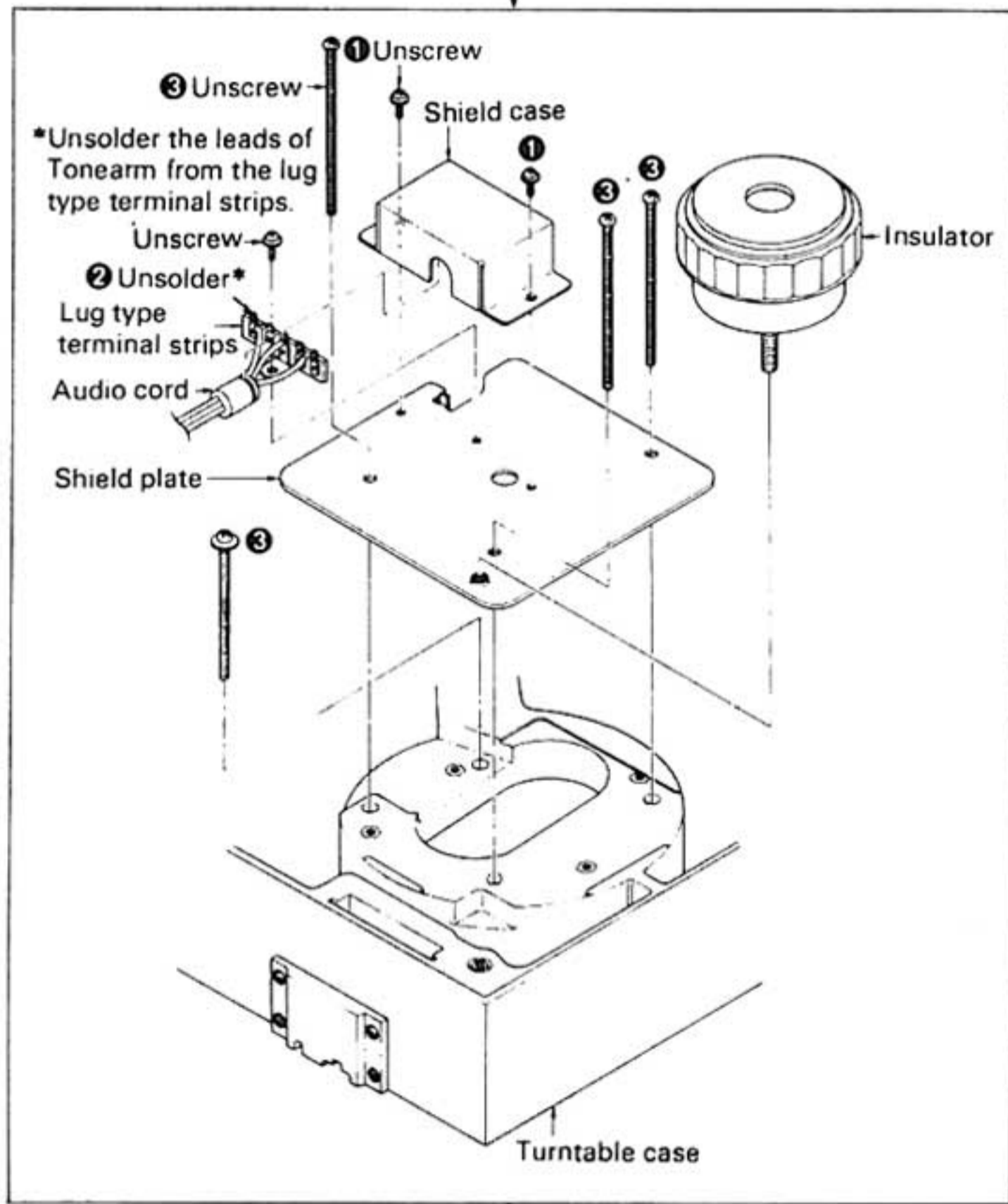

Tonearm Ass'y

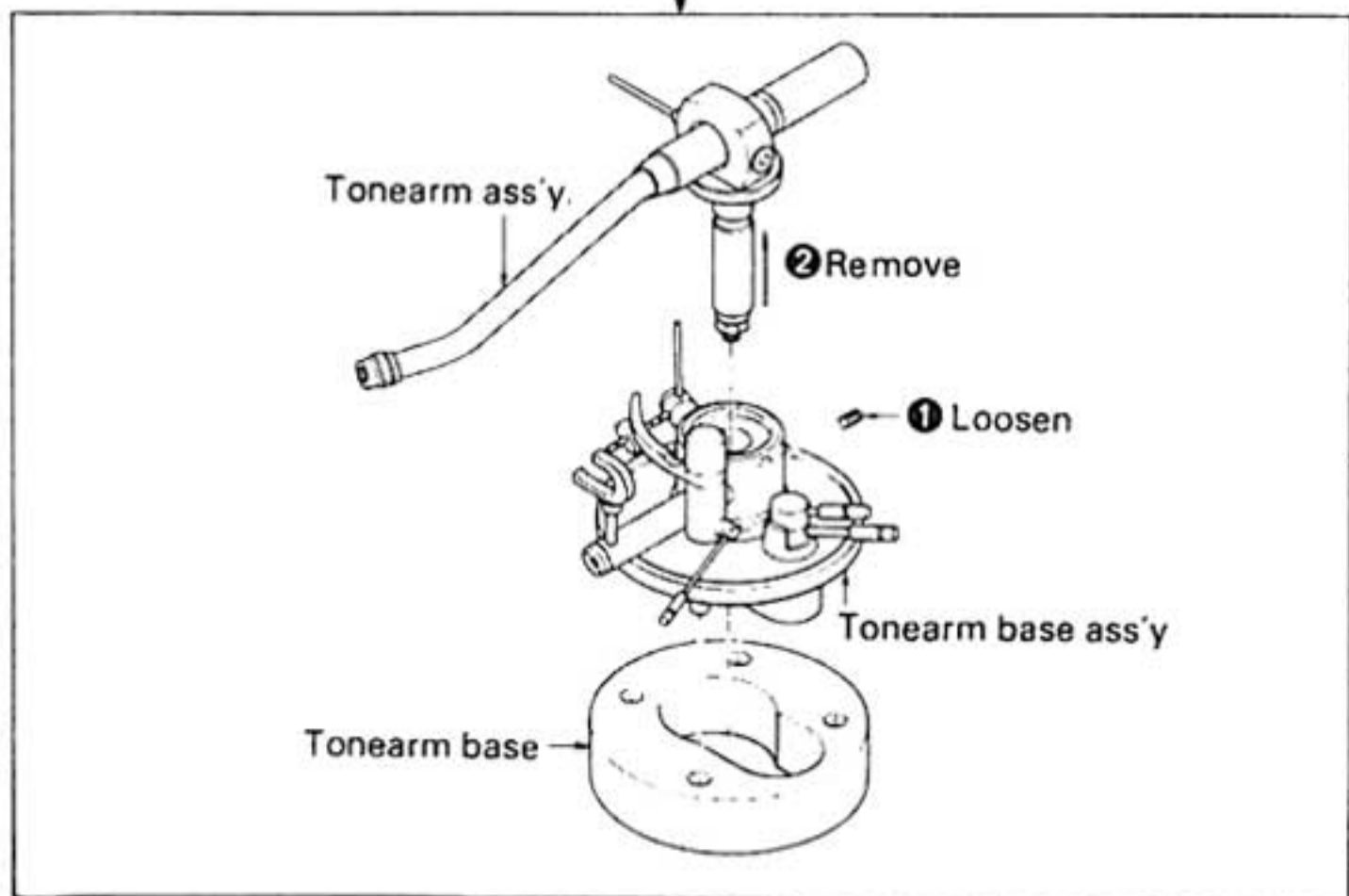

Switch

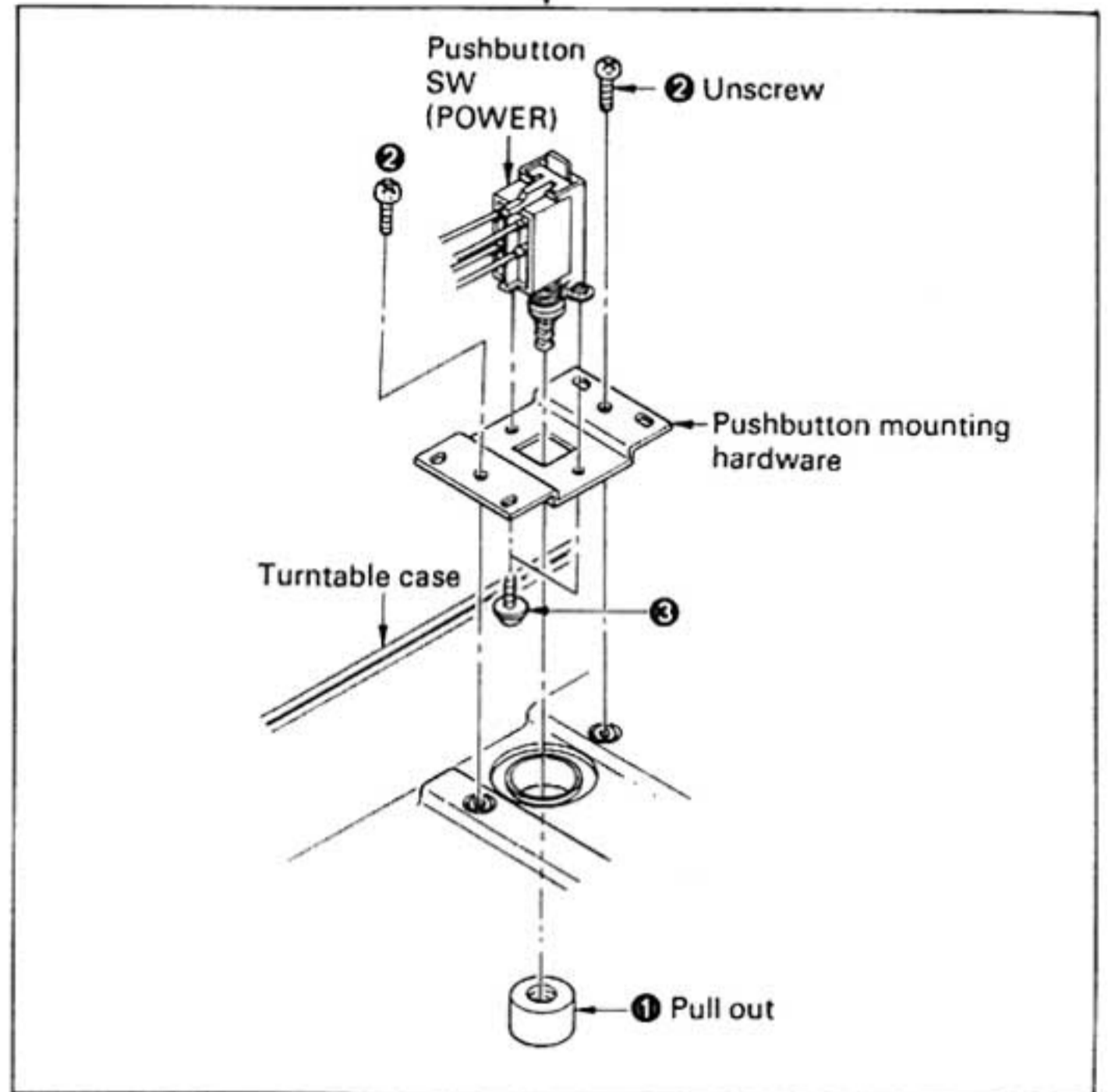

Slide Shaft Ass'y

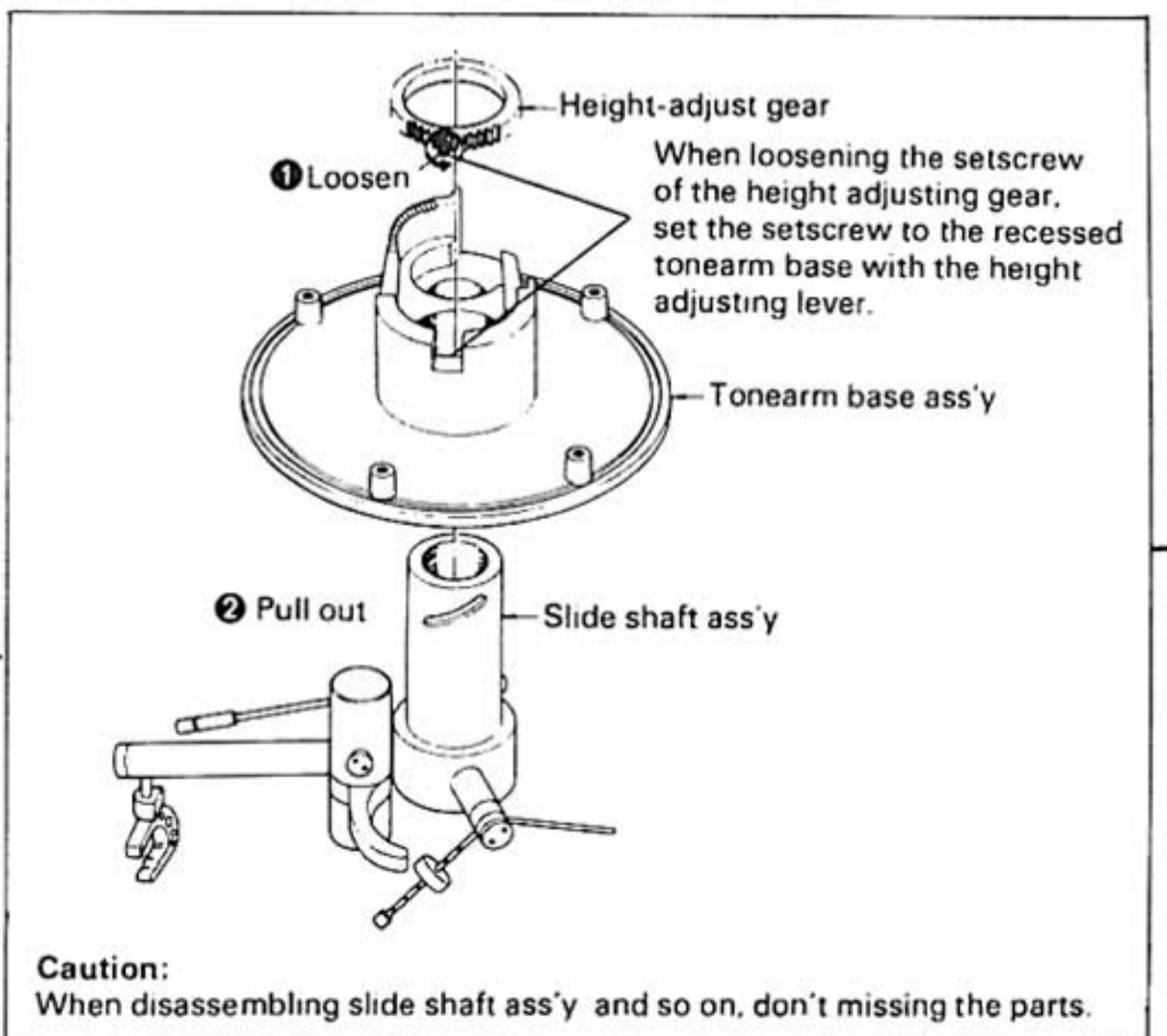

DISASSEMBLY FOR REPAIR

Power Transformer

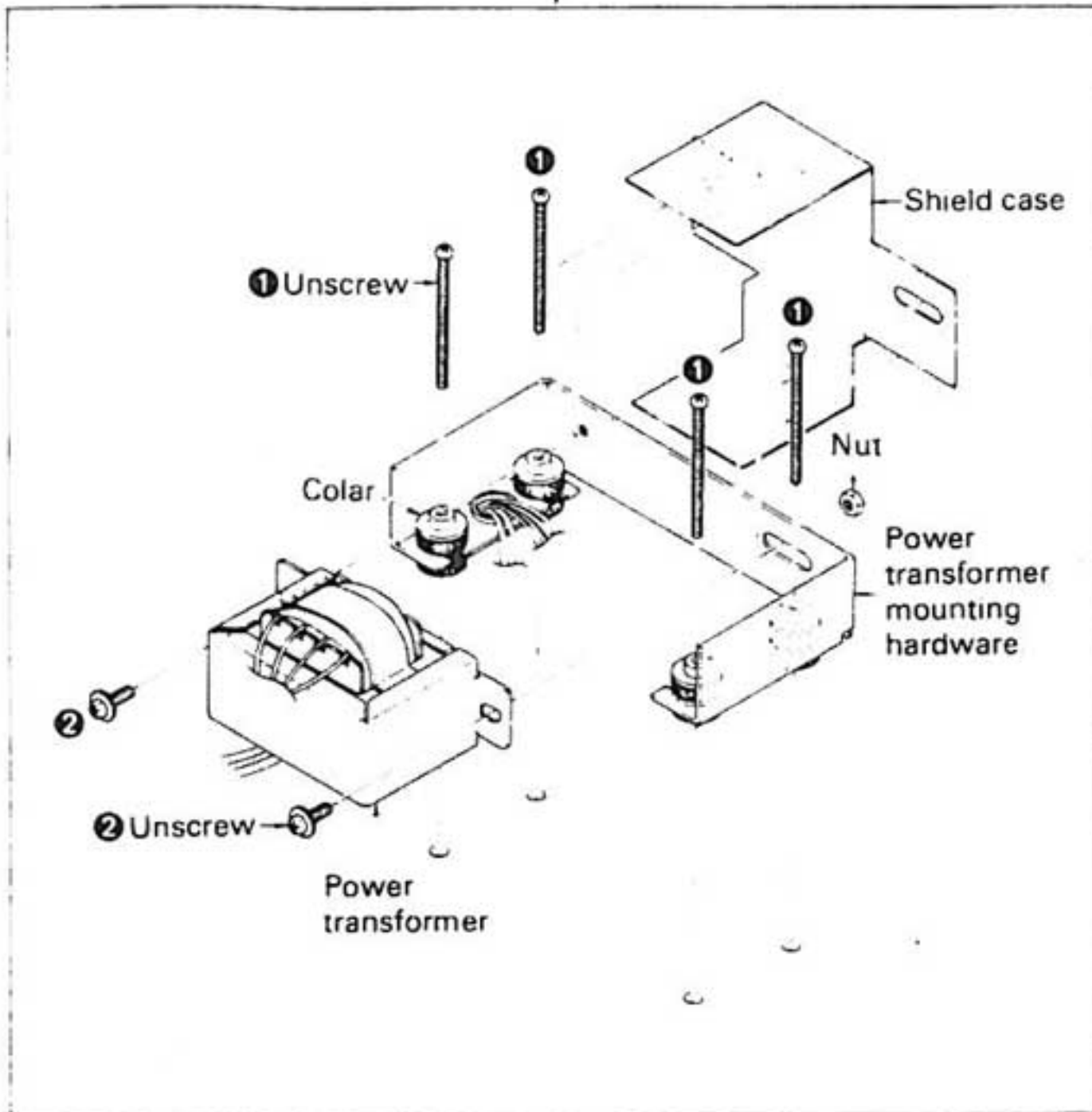

Indicator Ass'y

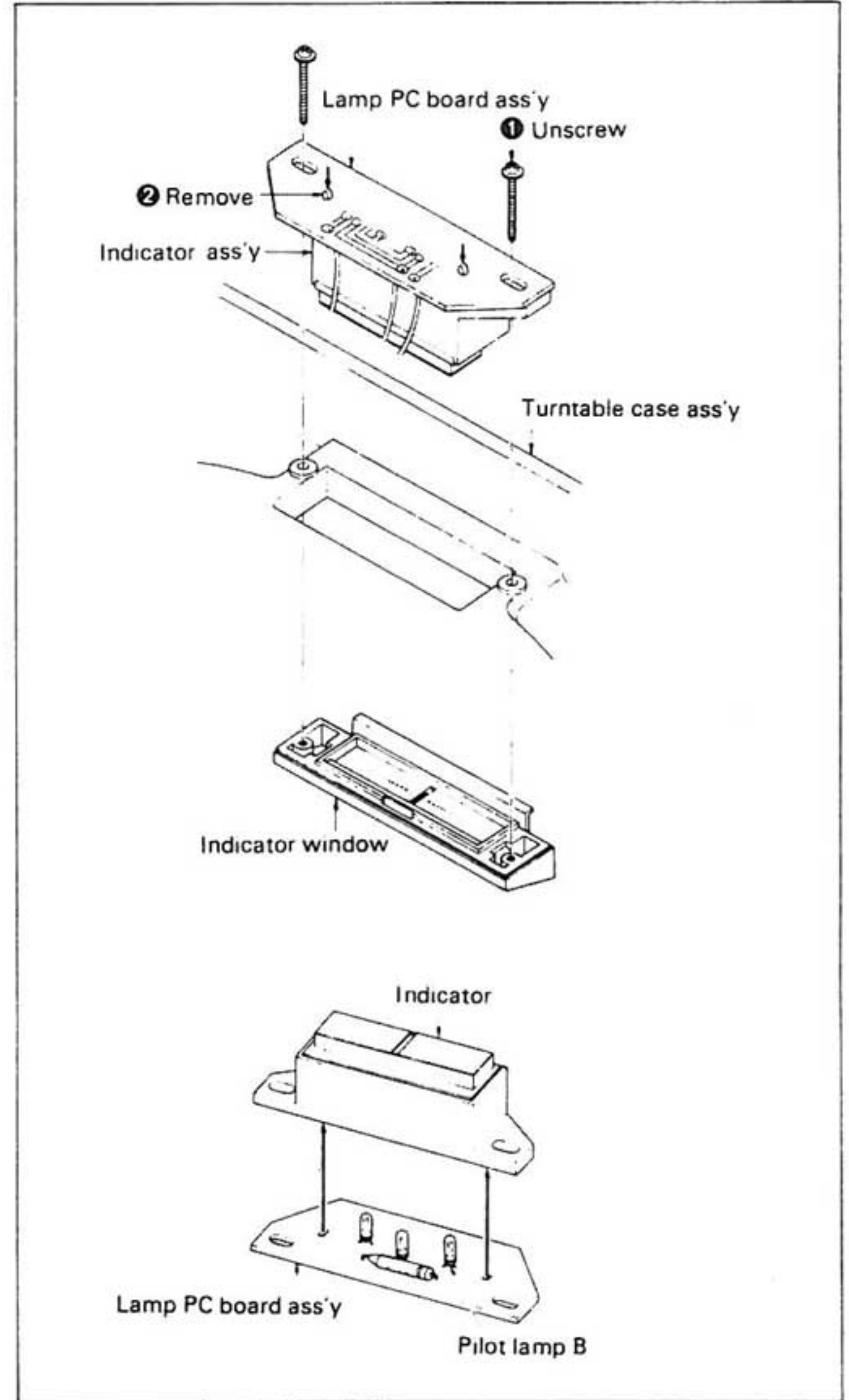

Lever

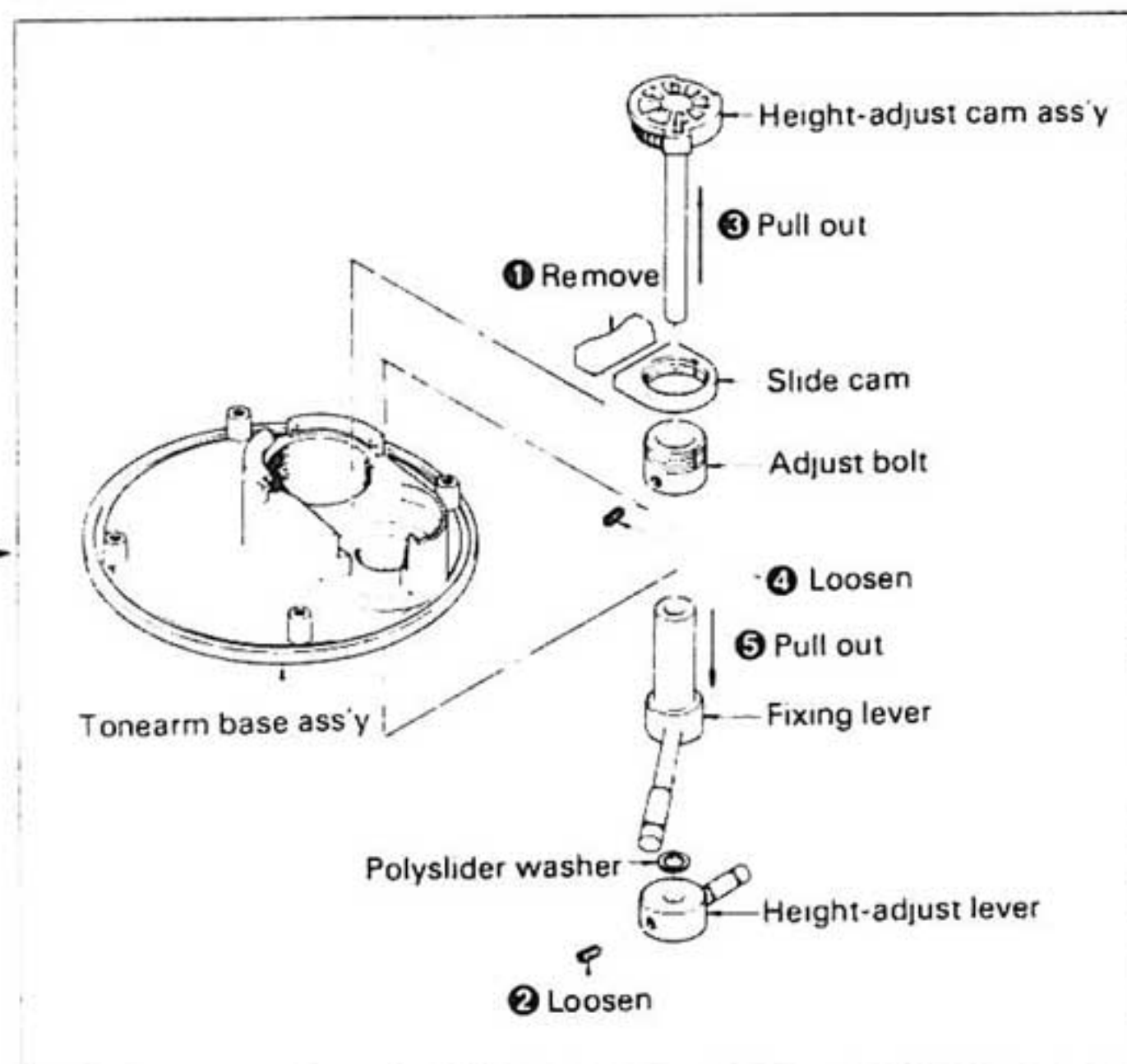

ADJUSTMENTS

BEFORE ADJUSTMENT

- Recommended Equipments are oscilloscope and d.c. voltmeter having input impedance of 1M ohms or more.
- Motor should be loaded with the turntable platter and the turntable sheet
- Set the turntable to the even position
- Turn the trimming potentiometers VR1 and 2 (white) on the control pcb ass'y to their mechanical center
- Connection cable to the oscilloscope should be used probe
- Before lock indicator adjustment, do PLL adjustment

KD-650 (600) has 4 adjustment points Use the following procedure to adjust the trimming potentiometers

LOCK INDICATOR ADJUSTMENT (BRAKE-OFF TIMING ADJUSTMENT)

- 1 Connect the DC voltmeter to TP V on the control PCB ass'y
- 2 Set the power switch to on and turn the trimming potentiometer VR1 so that the voltmeter indicate 265 mV when the turntable is in the correct speed condition
- 3 33-1/3 rpm (VR2) adjustment do the same way so that of 45 rpm

PLL ADJUSTMENT (WITH SINGLE TRACE OSCILLOSCOPE)

- 1 Connect the oscilloscope to TP R on the PC board
- 2 Push the POWER switch and set the waveform as Fig 1
- 3 Connect the output of TP R to EXT input on the oscilloscope (Don't touch the knobs.)
- 4 Connect the output of TP F to V input on the oscilloscope as Fig 2
- 5 Set the speed selector indicator to 33-1/3 rpm with touching the operation button
- 6 Turn the trimming potentiometer VR4 so that the waveform of TP F stops as Fig 2
- 7 45 rpm adjustment do the same way as that of 33-1/rpm (VR3)

PLL ADJUSTMENT (WITH DUAL TRACE OSCILLOSCOPE)

- 1 Connect the output of TP R and TP F to input jack, respectively
- 2 Expand the waveform of TP R
- 3 Stop the waveform of TP F as the following figure with the trimming potentiometers

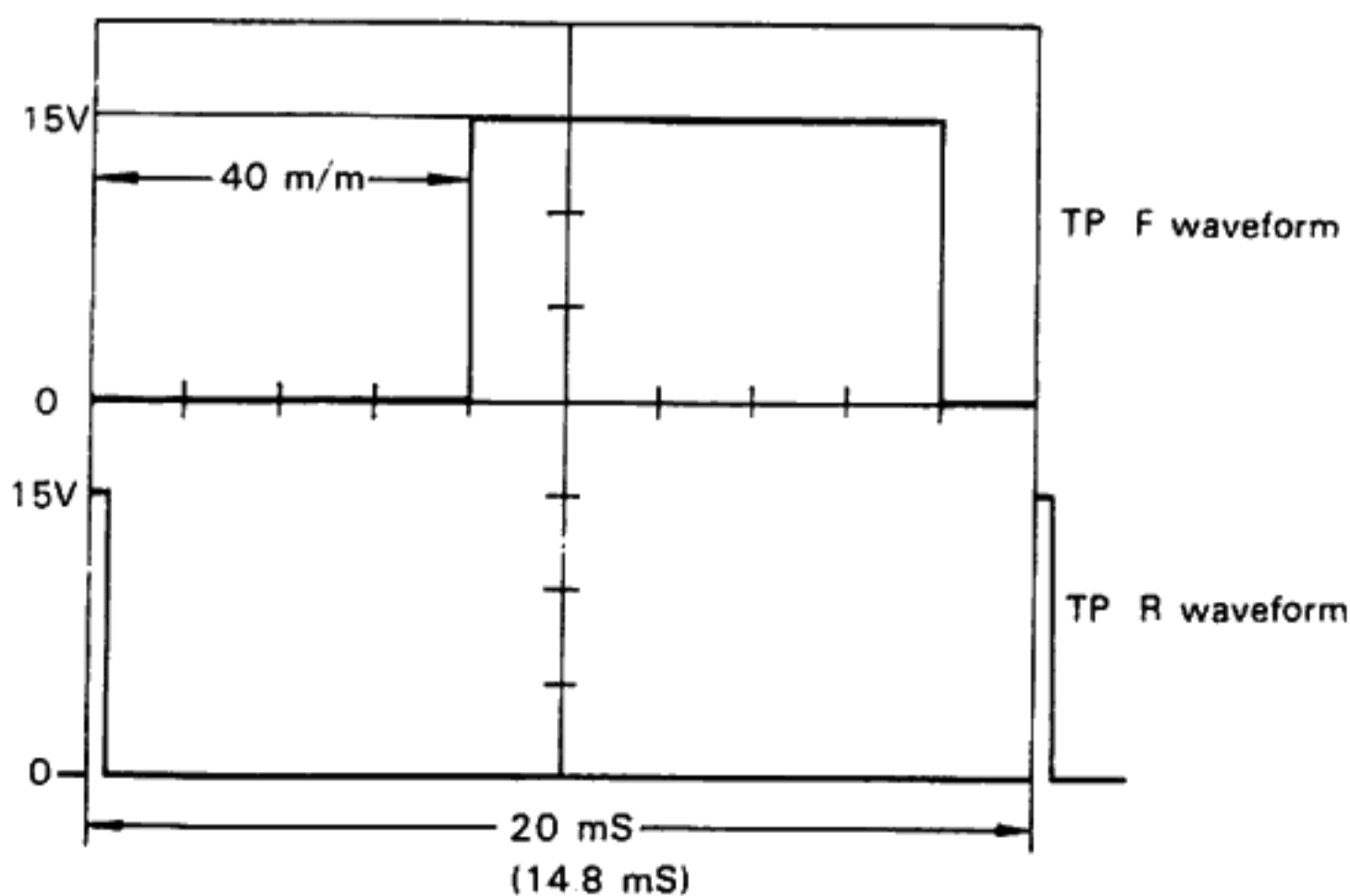

When turntable is set to 45 rpm, pulse period becomes 14.8 mS

< Sample Waveform with Dual Trace Oscilloscope >

ADJUSTMENTS

Fig. 1

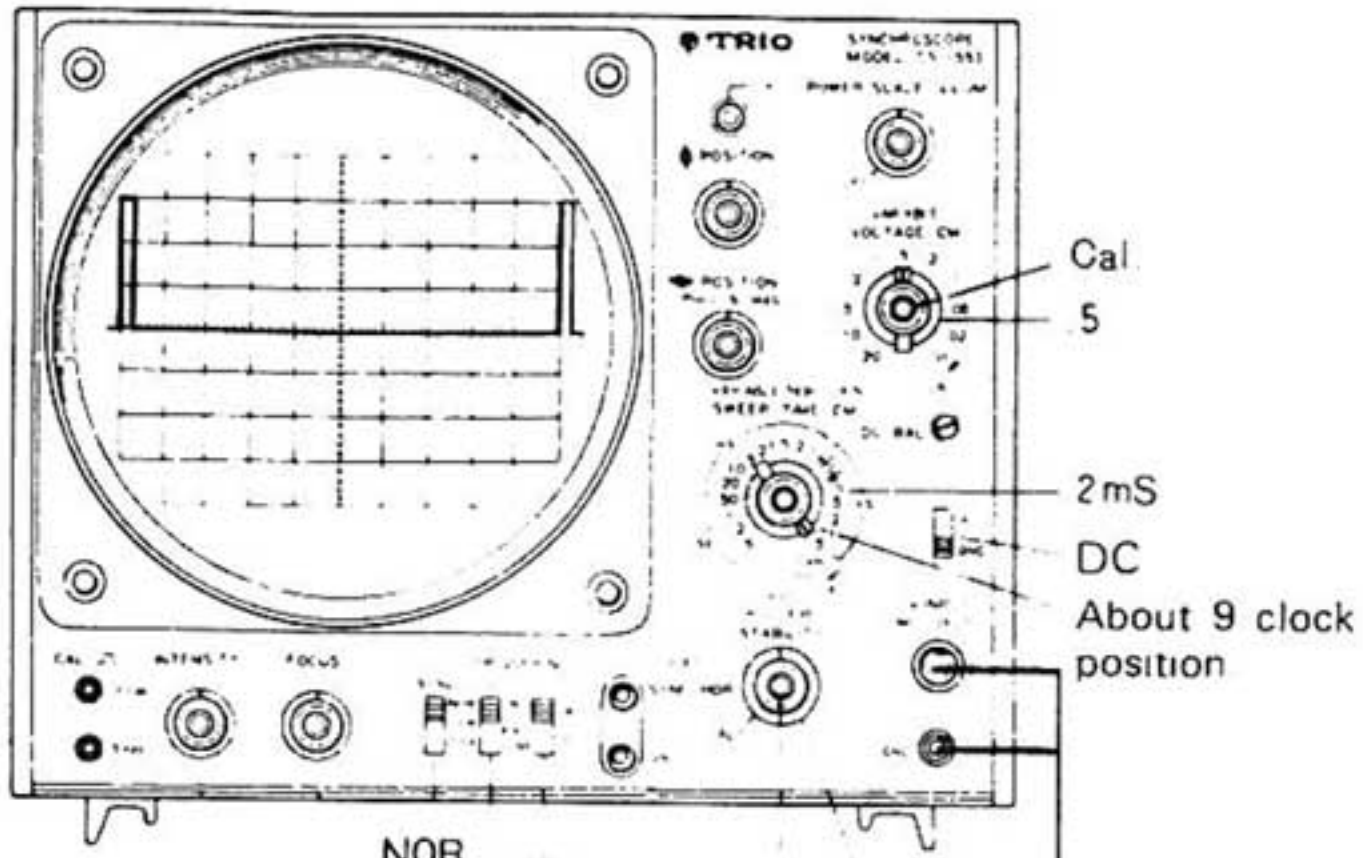

Set the knob to STOP position of waveform as above figure

Fig. 2

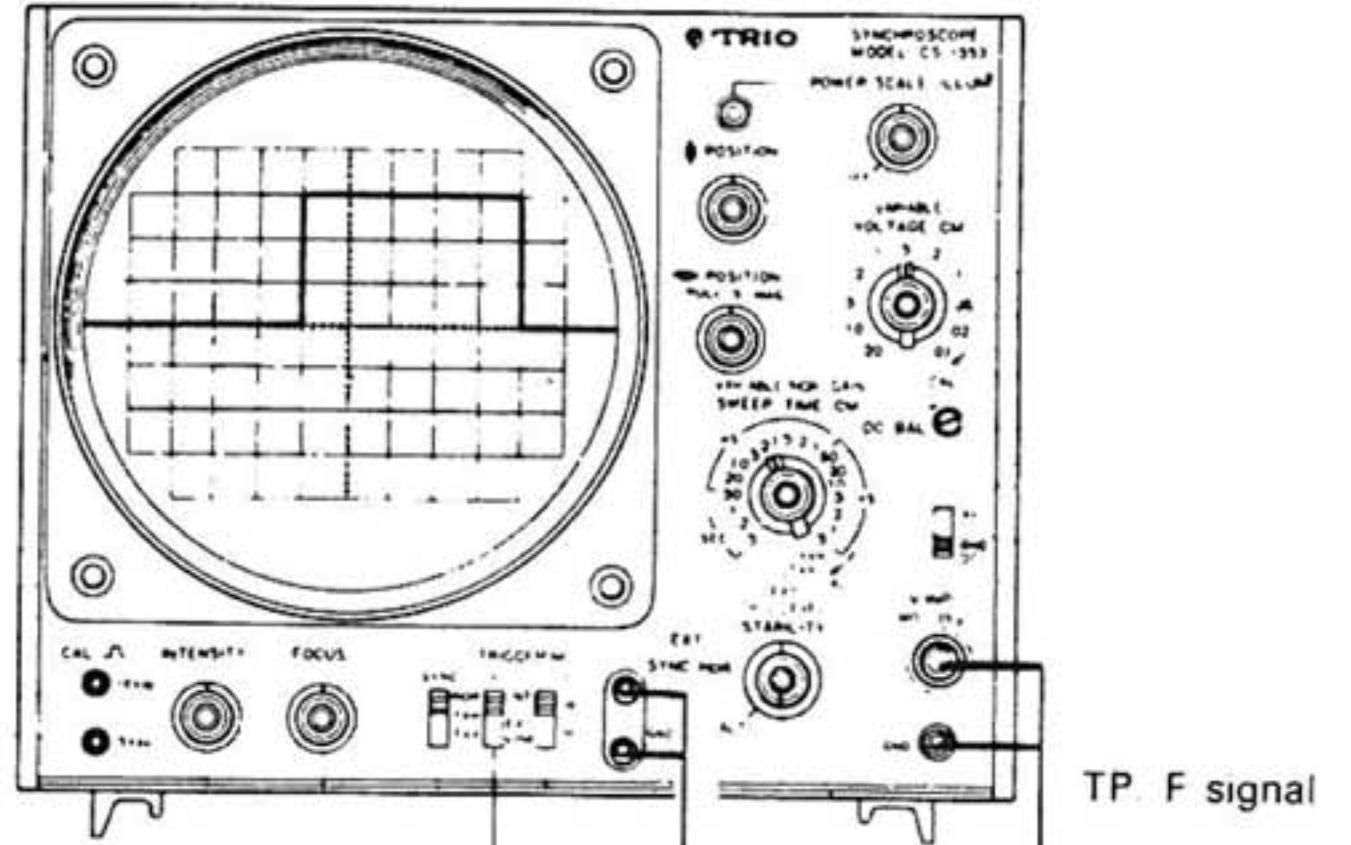

If oscilloscope has capacitive oscillation, it is not easy to adjust the turntable speed. In this case, connect the resistor 10 k Ω to input jack of oscilloscope in series. When adjusting the 45 rpm, set the SEEP TIME to 1 μ s and turn the VARIABLE of SEEP TIME so that waveform is expanded as 33-1/3 rpm adjustment.

When using the dual trace oscilloscope, connect the TP F to Ch. 1 of oscilloscope and TP R to Ch. 2 of that and adjust the trimming pot as single trace oscilloscope.

Probe (10.1)

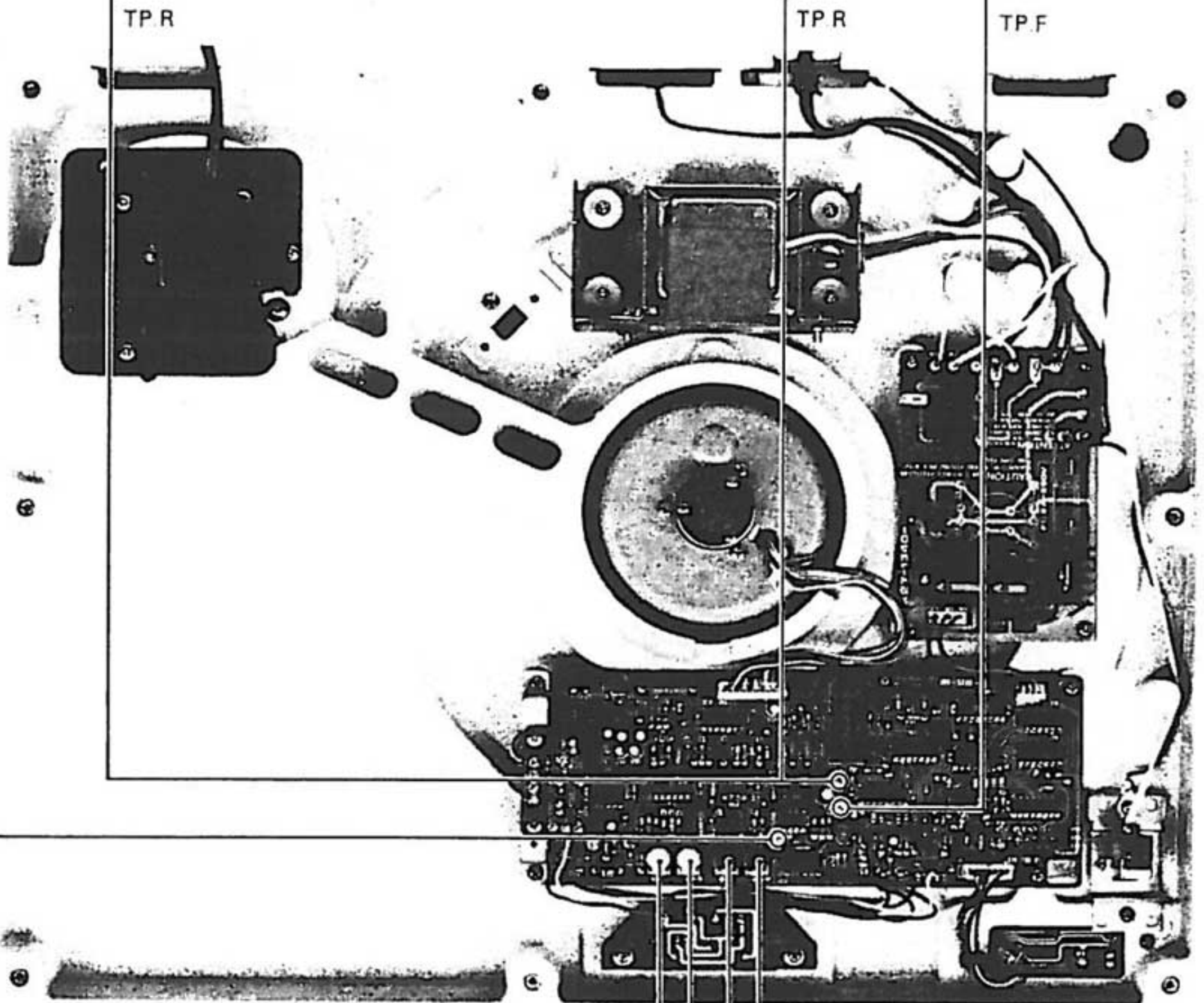

DC VTVM 265 mV

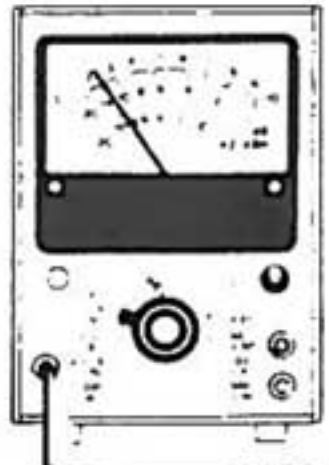

LOCK INDICATOR { VR1 VR2 } PLL { VR3 VR4 }

EXPLODED VIEW

A

B

1

2

3

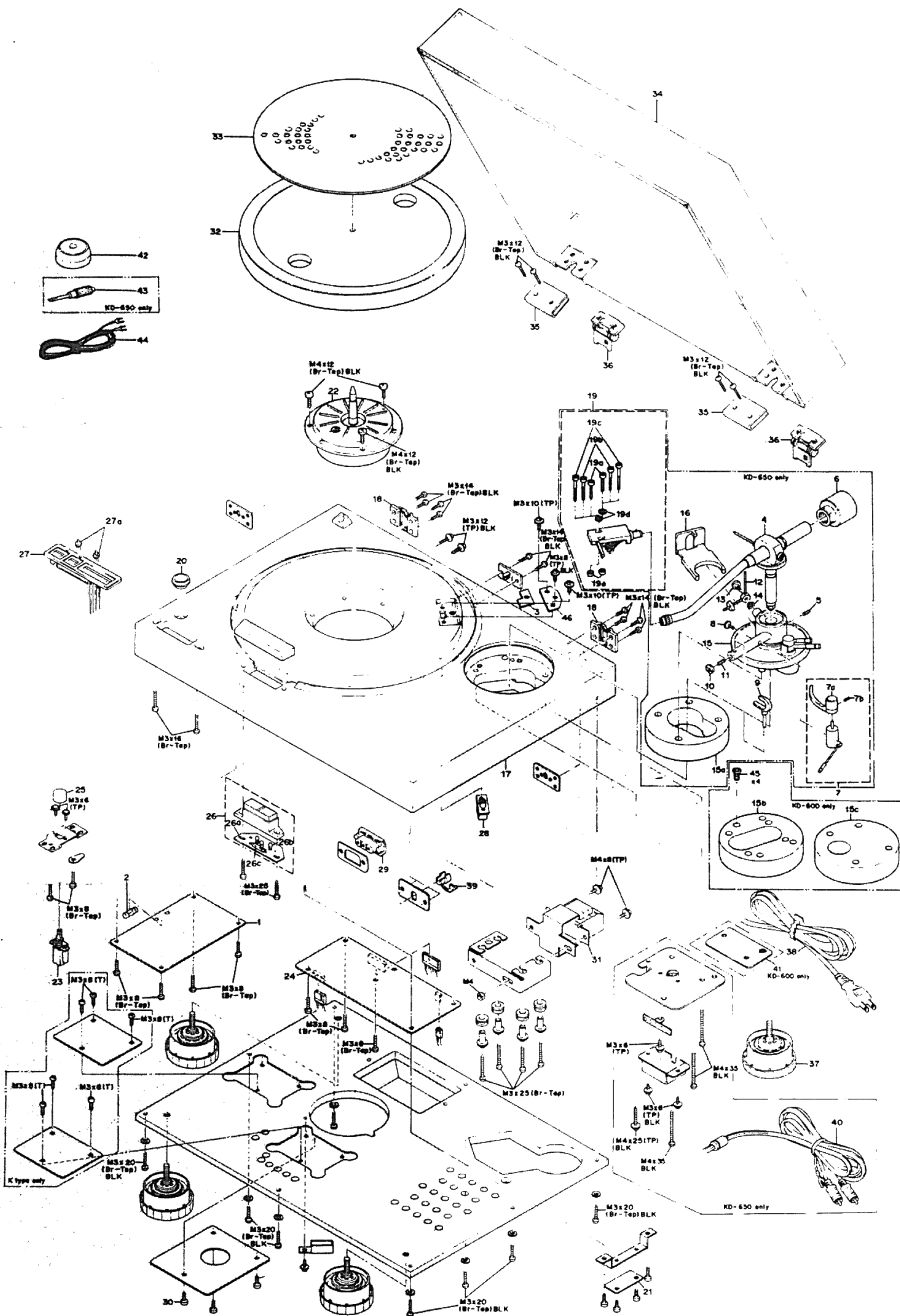

EXPLODED VIEW PARTS LIST

New Parts ★ Refer to Destinations: Parts List

Ref No	Parts No	Description	Re- marks	Ref No	Parts No.
1	★	Power supply PCB ass'y	3A	M3 × 6 (TP)	N90-3006-46
2	★	Fuse	2A	M3 × 6 (TP) BLK	N90-3006-45
3	★	Switch stopper	2B	M3 × 8 (Br-Tap)	N87-3008-46
4	J91-0118-08	Tonearm ass'y	2B	M3 × 8 (T)	N09-0215-04
5	N77-4010-45	Setscrew	2B	M3 × 8 (TP) BLK	N90-3008-45
6	D91-0116-08	Weight ass'y	2B	M3 × 10 (TP)	N90-3010-46
7	J19-1287-08	Elevation ass'y	2B	M3 × 12 (TP) BLK	N90-3012-46
7a	J19-1289-08	Elevation bar ass'y	2B	M3 × 12 (Br-Tap) BLK	N87-3012-45
7b	N77-3006-45	Setscrew	2B	M3 × 14 (Br-Tap) BLK	N87-3014-45
8	N08-0409-08	Dress screw A	2B	M3 × 16 (Br-Tap)	N87-3016-46
9	D39-0084-08	Tonearm rest	2B	M3 × 20 (Br-Tap) BLK	N87-3020-45
10	N13-0201-08	Dress nut	2B	M3 × 25 (Br-Tap)	N87-3025-46
11	N09-0847-08	Setscrew	2B	M4 × 8 (TP)	N90-4008-46
12	D19-0215-08	Inside force canceller ass'y	2B	M4 × 12 (Br-Tap) BLK	N87-4012-45
13	N08-0410-08	Dress screw B	2B	M4 × 25 (TP) BLK	N90-4025-45
14	N19-0549-08	Inside force canceller stopping washer	2B	M4 × 35 BLK	N30-4035-45
15a	J19-1286-08	Tonearm base ass'y	2B	M4	N10-2040-46
16	J42-0317-08	Shipping tonearm stopper	2B		
17	★	Turntable case ass'y	2B		
18	J21-2302-05	Hinge mounting hardware	2A,2B		
19	J92-0053-15	Head shell ass'y	1B		
19a	N09-0850-04	Cartridge mounting screw (M2.6 × 10)	2B		
19b	N09-0851-04	Cartridge mounting screw (M2.6 × 14)	1B		
19c	N09-0852-04	Cartridge mounting screw (M2.6 × 20)	1B		
19d	N19-0175-09	Cartridge mounting washer	2B		
19e	N14-0412-04	Cartridge mounting nut	2B		
20	B07-0538-14	Switch base	2A		
21	X25-1400-00	Muting PCB ass'y	3B		
22	T43-0017-05	Motor ass'y	1A		
23	★	Power switch	3A		
24	★	Control PCB ass'y	3A		
25	K29-0650-14	Power switch knob (1)	2A		
26	B08-9208-04	Indicator ass'y	2A		
26a	B38-0208-05	Lamp PCB ass'y	2A		
26b	B30-0716-05	Pilot lamp (B)	2A		
26c	B30-0717-05	Pilot lamp (C)	2A		
27	D40-0451-05	Operation ass'y	2A		
27a	V11-3400-10	LED (GL-2PR1)	2A		
28	★	Slide switch	2B		
29	★	Voltage selector	2B		
30	N09-0595-04	Taping screw (φ3 × 10) BLK	3A		
31	★	Power transformer	3B		
32	D02-0021-15	Turntable platter	1A		
33	★	Turntable sheet	1A		
34	A53-0213-12	Turntable cover	1B		
35	J50-0315-04	Hinge (2)	1B		
36	J50-0314-05	Hinge (1)	1B		
37	J02-0328-05	Insulator	3B		
38	★	Power cord	3B		
39	★	Cord bushing	2B		
40	E30-1333-05	Audio cord	3B		
41	★	Insulator mounting hardware	3B		
42	W01-0304-04	EP adapter	1A		
43	W01-0305-05	Small driver	1A		
44	E30-1301-05	GND wire	1A		
45	★	Bolt	2B		
46	★	Hole cover plate	2B		

PARTS LIST

☆ : New Parts

Ref No	Parts No.	Description	Re- marks	Ref No	Parts No.	Description	Re- marks
MUTING PCB ASS'Y (X25-1400-00)							
C101~103	C24-6522-67	Electrolytic 22 μ F 35WV		R118	R48-2222-64	RN 22.6k Ω \pm 2% 1/4W	
R102	R92-0501-05	Frame-proof RD 82 Ω \pm 10% 1/2W	☆	R119	R48-2240-24	RN 24k Ω \pm 2% 1/4W	
Q1	V03-0270-05	Transistor 2SC945 (Q, R)		R124	R48-2220-04	RN 22k Ω \pm 2% 1/4W	
POWER SUPPLY PCB ASS'Y (X27-1340-01)							
C101	C54-3310-39	Spark killer 0.01 μ F 2KV (X27-1340-03)		R125	R48-2240-24	RN 24k Ω \pm 2% 1/4W	
C103	C91-0309-05	Film 0.047 μ F \pm 5% (X27-1340-04, -05)		R141,142	R48-2220-24	RN 22k Ω \pm 2% 1/4W	
	C91-0302-05	Spark killer (X27-1340-01)		R148	R48-2240-24	RN 24k Ω \pm 2% 1/4W	
	C91-0024-05	Spark killer (X27-1340-02)		R150	R48-2118-23	RN 11.8k Ω \pm 1% 1/4W	
	C54-3310-39	Spark killer 0.01 μ F 2KV (X27-1340-03)		R152	R48-2110-23	RN 11k Ω \pm 1% 1/4W	
C104	C90-0295-05	Ceramic 0.1 μ F \pm 20%		R157	R48-2120-34	RN 120k Ω \pm 2% 1/4W	
C105	C90-0704-05	Electrolytic 2200 μ F 35WV		R160	R48-2270-34	RN 270k Ω \pm 2% 1/4W	
C106	C90-0295-05	Ceramic 0.1 μ F \pm 20%		R172~174	R92-0504-05	RN 10M Ω \pm 1% 1/4W	☆
—	J13-0052-05	Fuse holder \times 2		R175~177	R92-0503-05	RN 5.1M Ω \pm 1% 1/4W	☆
D1	V11-2400-20	Diode W02		R181	R43-1212-25	Flame-proof RD 1.2k Ω \pm 5% 1/4W	☆
IC1	V30-0310-10	IC μ PC78M15H	☆	R182	R43-1315-05	Flame-proof RD 15 Ω \pm 5% 1/2W	☆
CONTROL PCB ASS'Y (X29-1120-01)							
C101~103	C24-1733-57	Electrolytic 3.3 μ F 50WV		R183	R42-6233-25	Flame-proof RD 3.3k Ω \pm 5% 1/2W	
C104~106	C24-1722-57	Electrolytic 2.2 μ F 50WV		Q1~3	V04-0793-10	Transistor 2SD793 (R, Q)	☆
C107~108	C46-1710-47	Mylar 0.1 μ F \pm 20%	☆	Q4~6	V01-0733-50	Transistor 2SA733A (Q)	☆
C109~111	C46-1710-26	Mylar 0.001 μ F \pm 10%		Q7	V01-0733-30	Transistor 2SA733A (R, Q)	
C112~114	C46-1733-26	Mylar 0.0033 μ F \pm 10%		Q8,9	V03-0270-05	Transistor 2SC945 (Q, R)	
C115	C46-1710-36	Mylar 0.01 μ F \pm 10%		Q10	V01-0733-30	Transistor 2SA733A (R, Q)	
C116	C46-1756-26	Mylar 0.0056 μ F \pm 20%		Q11	V03-0270-05	Transistor 2SC945 (Q, R)	
C117	C46-1715-46	Mylar 0.15 μ F \pm 10%	☆	Q12~14	V03-0293-05	Transistor 2SC945 (Q)	
C118,119	C91-0320-05	Film 0.1 μ F 50WV	☆	Q15,16	V01-0733-30	Transistor 2SA733A (R, Q)	
C120,121	C91-0321-05	Film 0.1 μ F 50WV	☆	Q17	V03-2003-30	Transistor 2SC2003 (L, K)	☆
C122	C29-1447-51	Electrolytic 4.7 μ F 25WV	☆	Q18	V03-0270-05	Transistor 2SC945 (Q, R)	
C123,124	C59-1722-05	Ceramic 22pF \pm 5%		IC1	V30-0290-10	IC SAS560S	☆
C125	C53-1710-37	Ceramic 0.01 μ F \pm 20%		IC2	V30-0304-10	IC CD4011BE or	☆
C126	C46-1733-36	Mylar 0.033 μ F \pm 10%	☆		V30-0304-20	CD4011BCN	☆
C127	C24-1747-47	Electrolytic 0.47 μ F 50WV		IC3	V30-0303-10	IC CD4001BE or	☆
C128	C46-1710-36	Mylar 0.01 μ F \pm 10%			V30-0303-20	CD4001BCN	☆
C129~131	C52-1756-16	Ceramic 560pF \pm 10%		IC4,5	V30-0305-10	IC CD4027BE or	☆
C132	C24-1710-57	Electrolytic 1 μ F 50WV			V30-0305-20	CD4027BCN	☆
C133	C24-1447-51	Electrolytic 4.7 μ F 25WV		IC6	V30-0309-10	IC CD40106BE or	☆
C134	C24-6522-61	Electrolytic 22 μ F 35WV			V30-0309-20	CD40106BCN	☆
C135	C71-1722-06	Ceramic 22pF \pm 5%		IC7	V30-0306-10	IC CD4049UB or	☆
C136~138	C46-1710-37	Mylar 0.01 μ F \pm 20%			V30-0306-20	CD4049CN	☆
C139	C24-1710-57	Electrolytic 1 μ F 50WV		IC8	V30-0263-10	IC SN16889P	
—	F05-1013-05	Fuse (0.1A) (X29-1120-02)		IC9	V30-0250-30	IC SM6415A-4S	☆
—	J13-0301-05	Fuse clip \times 2 (X27-1120-02)	☆	IC10	V30-0256-10	IC CA324G	
—	L77-0569-05	Crystal (9.5040MHz, \pm 20ppm)	☆	IC11	V30-0307-10	IC CD4066BE or	☆
VR1	R12-3050-05	Trimming potentiometer 33k Ω (B) Lock indicator	☆		V30-0307-20	CE4066BCN	☆
VR2	R12-3051-05	Trimming potentiometer 22k Ω (B) Lock indicator	☆	IC12	V30-0308-10	IC MM74C906N	☆
VR3	R12-1043-05	Trimming potentiometer 2.2k Ω (B) PLL	☆	IC13	V30-0302-10	IC CA741CG	☆
VR4	R12-1041-05	Trimming potentiometer 3.3k Ω (B) PLL	☆	D1	V11-4103-30	Zener diode XZ-112	☆
R101	R47-1522-95	Flame-proof RS 2.2 Ω \pm 5% 2W		D2,3	V11-1200-80	Diode 1SS53	☆
				D4~6	V11-0051-05	Diode 1N60	
				D7,8	V11-1200-80	Diode 1SS53	☆
				D9	V11-1200-40	Diode 1SS55	
				D10	V11-0394-05	Zener diode WZ-050	
				D11,12	V11-1200-80	Diode 1SS53	☆
				—	W02-0202-05	Oscillation block	☆

DESTINATIONS' PARTS LIST

New Parts

Ref. No.	U.S.A. (K)	Canada (P)	PX (U)	Australia (X)	Europe (W)	Scandinavia (L)	England (T)	South Africa (S)	Other Area (M)	Audio Club (H)	Description
17	A09-0316-05	A09-0316-05	A09-0316-05	A09-0316-05	A09-0316-05	A09-0316-05	A09-0318-05	A09-0316-05	A09-0316-05	A09-0316-05	Turntable case (KD-600) ☆
17	A09-0315-05	A09-0315-05	A09-0315-05	A09-0315-05	A09-0315-05	A09-0315-05	A09-0317-05	A09-0315-05	A09-0315-05	A09-0315-05	Turntable case (KD-650) ☆
—	B46-0061-20	B46-0055-20	B46-0062-20	B46-0064-00	—	—	B46-0060-00	—	—	B46-0062-20	Warranty card
—	—	—	B46-0063-00	—	—	—	—	—	—	—	Warranty card
—	B50-2295-00	B50-2296-00	B50-2295-00	B50-2296-00	B50-2295-00	B50-2295-00	B50-2297-00	B50-2295-00	B50-2296-00	B50-2295-00	Instruction manual ☆
3	—	—	—	D32-0080-24	—	—	—	—	—	—	Switch stopper (voltage selector)
29	—	—	E03-0102-05	—	E03-0102-05	E03-0102-05	E03-0102-05	E03-0102-05	E03-0102-05	E03-0102-05	Voltage selector
38	E30-0181-05	E30-0181-05	E30-1305-15	E30-0185-05	E30-1329-05	E30-1329-05	E30-1328-05	E30-1328-05	E30-1305-15	E30-1329-05	Power cord
2	F05-2021-05	F05-2021-05	F05-2023-05	F05-2023-05	F05-2029-05	F05-2029-05	F05-2029-05	F05-2023-05	F05-2023-05	F05-2029-05	Fuse (2A)
46	F07-0610-04	F07-0610-04	F07-0610-04	—	F07-0610-04	F07-0610-04	F07-0610-04	F07-0610-04	F07-0610-04	F07-0610-04	Hole cover plate
33	G16-0325-02	G16-0323-02	G16-0323-02	G16-0323-02	G16-0323-02	G16-0323-02	G16-0323-02	G16-0323-02	G16-0323-02	G16-0323-02	Turntable sheet
—	H01-2317-04	H01-2319-04	H01-2317-04	H01-2319-04	H01-2319-04	H01-2319-04	H01-2318-04	H01-2319-04	H01-2319-04	H01-2319-04	Carton box (KD-600) ☆
—	H01-2314-04	H01-2316-04	H01-2316-04	H01-2316-04	H01-2316-04	H01-2316-04	H01-2315-04	H01-2316-04	H01-2316-04	H01-2316-04	Carton box (KD-650) ☆
15b	J19-1285-04	J19-1285-04	J19-1285-04	J19-1285-04	J19-1285-04	J19-1285-04	J19-1285-04	J19-1285-04	J19-1285-04	J19-1285-04	Tonearm base (B) (KD-600) ☆
15c	J19-1284-04	J19-1284-04	J19-1284-04	J19-1284-04	J19-1284-04	J19-1284-04	J19-1284-04	J19-1284-04	J19-1284-04	J19-1284-04	Tonearm base (C) (KD-600) ☆
39	J41-0034-05	J41-0034-05	—	J41-0024-15	—	—	—	—	—	—	Cord bushing
41	J21-2303-04	J21-2303-04	J21-2303-04	J21-2303-04	J21-2303-04	J21-2303-04	J21-2303-04	J21-2303-04	J21-2303-04	J21-2303-04	Insulator mounting hardware (KD-600)
31	L01-6211-05	L01-6211-05	L01-6214-05	L01-6214-05	L01-6214-05	L01-6214-05	L01-6214-05	L01-6214-05	L01-6214-05	L01-6214-05	Power transformer ☆
45	N09-0279-05	N09-0279-05	N09-0279-05	N09-0279-05	N09-0279-05	N09-0279-05	N09-0279-05	N09-0279-05	N09-0279-05	N09-0279-05	Bolt (M4 x 30)
45	N09-0856-05	N09-0856-05	N09-0856-05	N09-0856-05	N09-0856-05	N09-0856-05	N09-0856-05	N09-0856-05	N09-0856-05	N09-0856-05	Bolt (M4 x 20)
23	S40-1304-05	S40-1304-05	S40-1304-05	S40-2306-05	S40-2306-05	S40-2306-05	S40-2306-05	S40-1304-05	S40-1304-05	S40-2306-05	Power switch ☆
28	—	—	—	S31-2001-05	—	—	—	—	—	—	Slide switch
—	—	—	T21-0055-05	—	—	—	—	—	—	—	Cartridge (DM-11) (KD-650)
1	X27-1340-01	X27-1340-02	X27-1340-04	X27-1340-05	X27-1340-03	X27-1340-03	X27-1340-03	X27-1340-04	X27-1340-04	X27-1340-03	Power supply PCB ass'y ☆
24	X29-1120-01	X29-1120-01	X-29-1120-01	X29-1120-01	X29-1120-02	X29-1120-02	X29-1120-02	X29-1120-01	X29-1120-01	X29-1120-02	Control PCB ass'y ☆
—	W09-0007-15	W09-0007-15	W09-0007-15	W09-0007-15	W09-0007-15	W09-0007-15	W09-0007-15	W09-0007-15	W09-0007-15	W09-0007-15	Wrench (KD-600)

PACKING

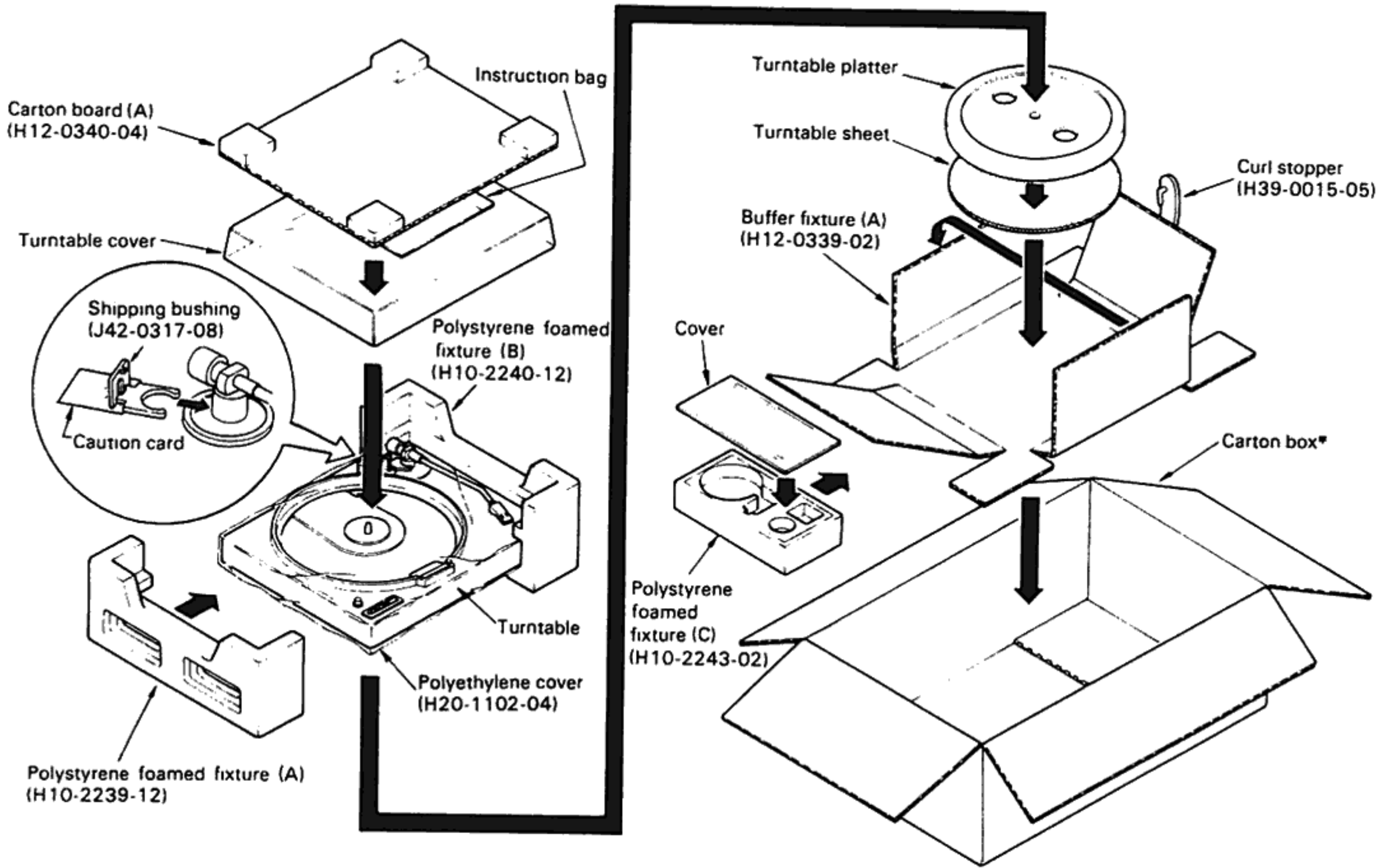

*Refer to Parts List

REVISED CIRCUIT

REVISED CIRCUIT

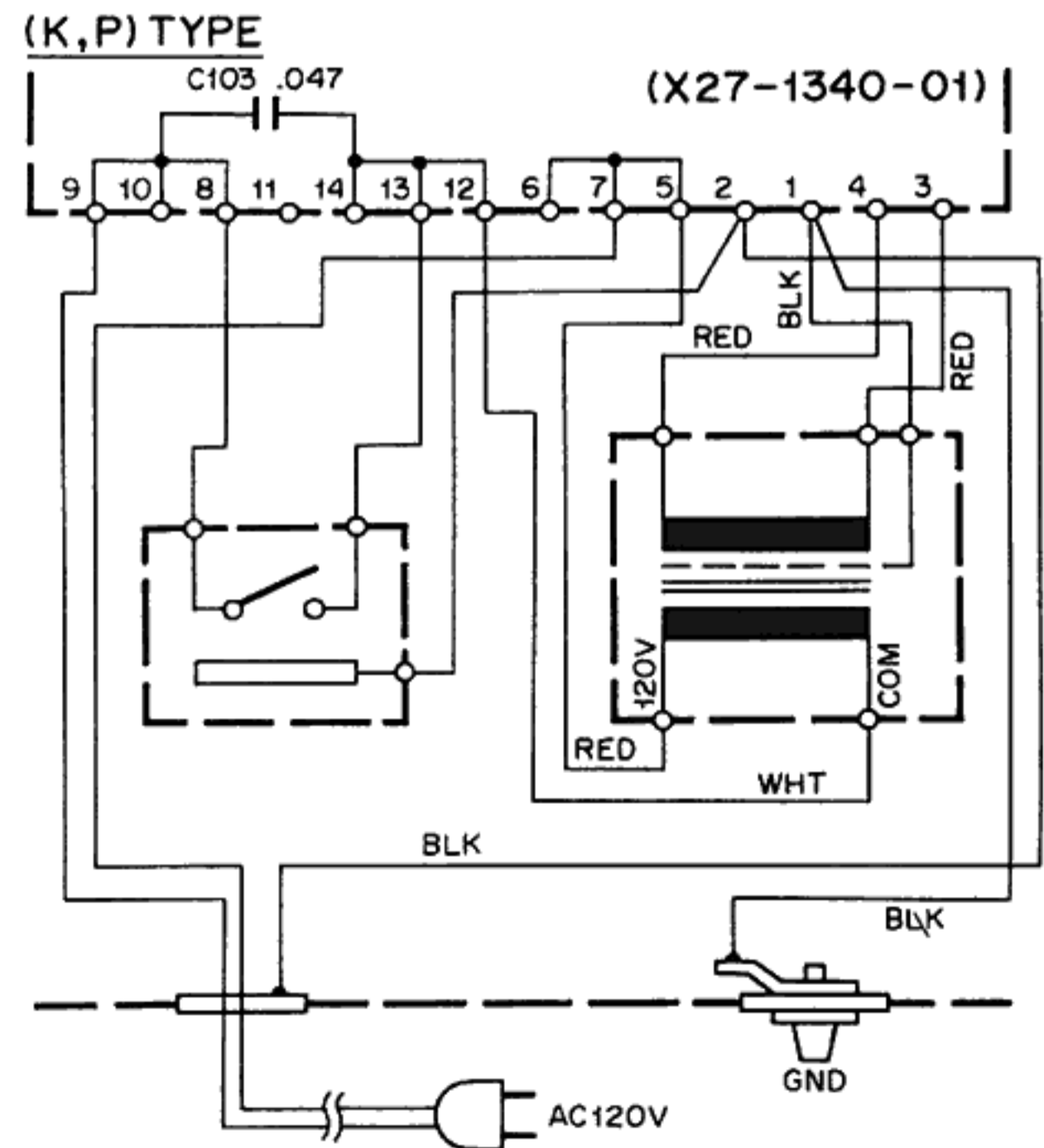
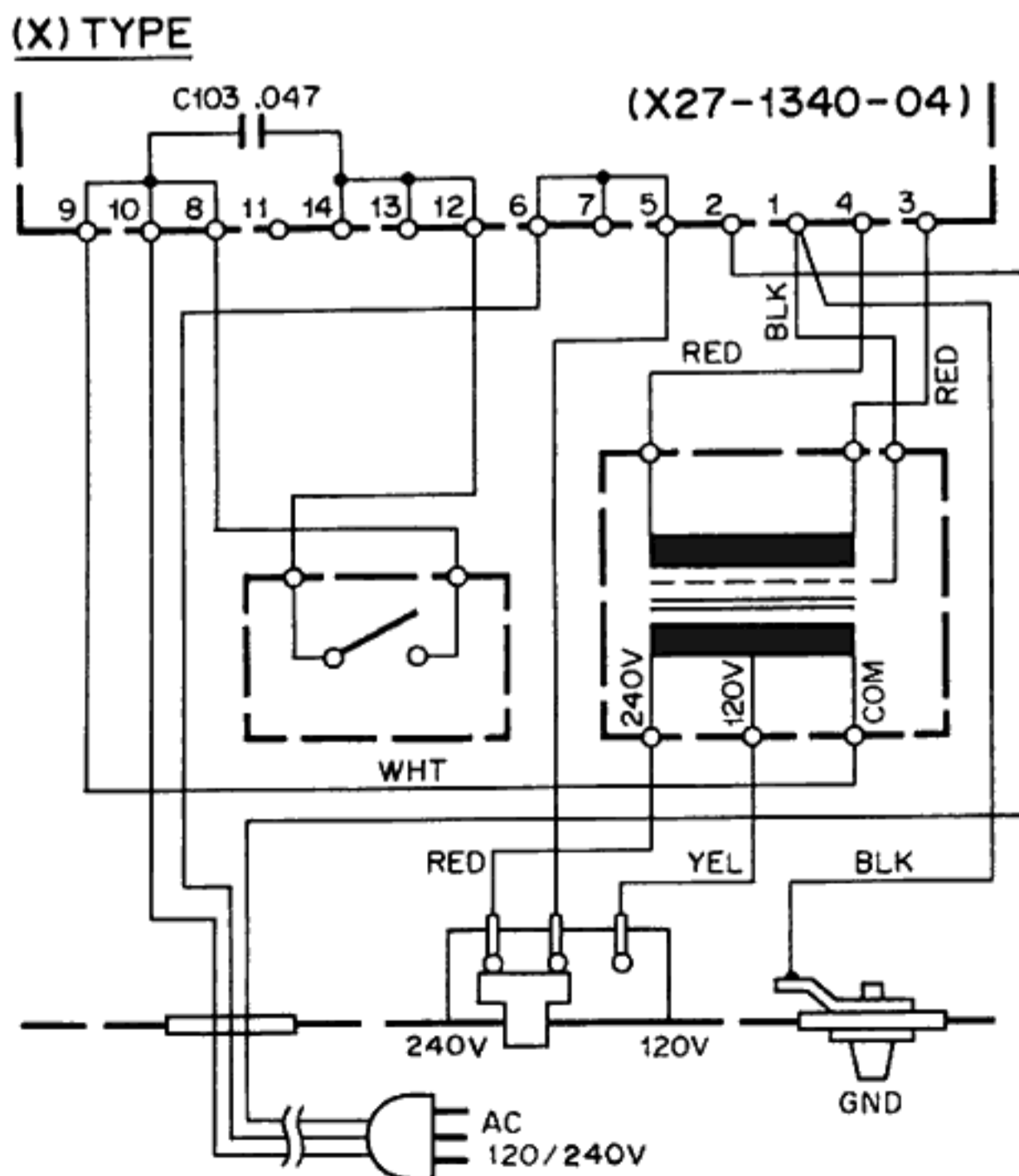
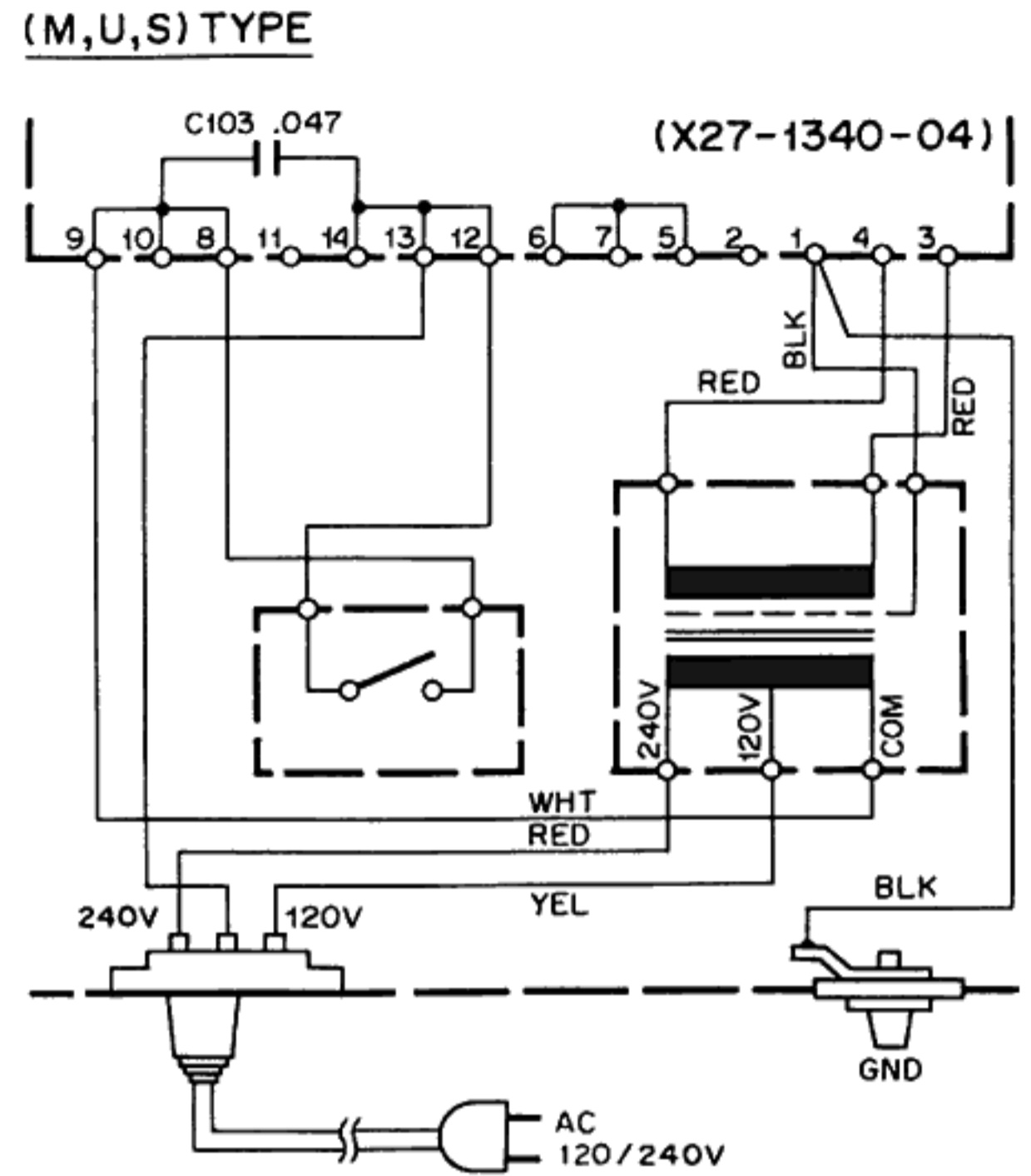
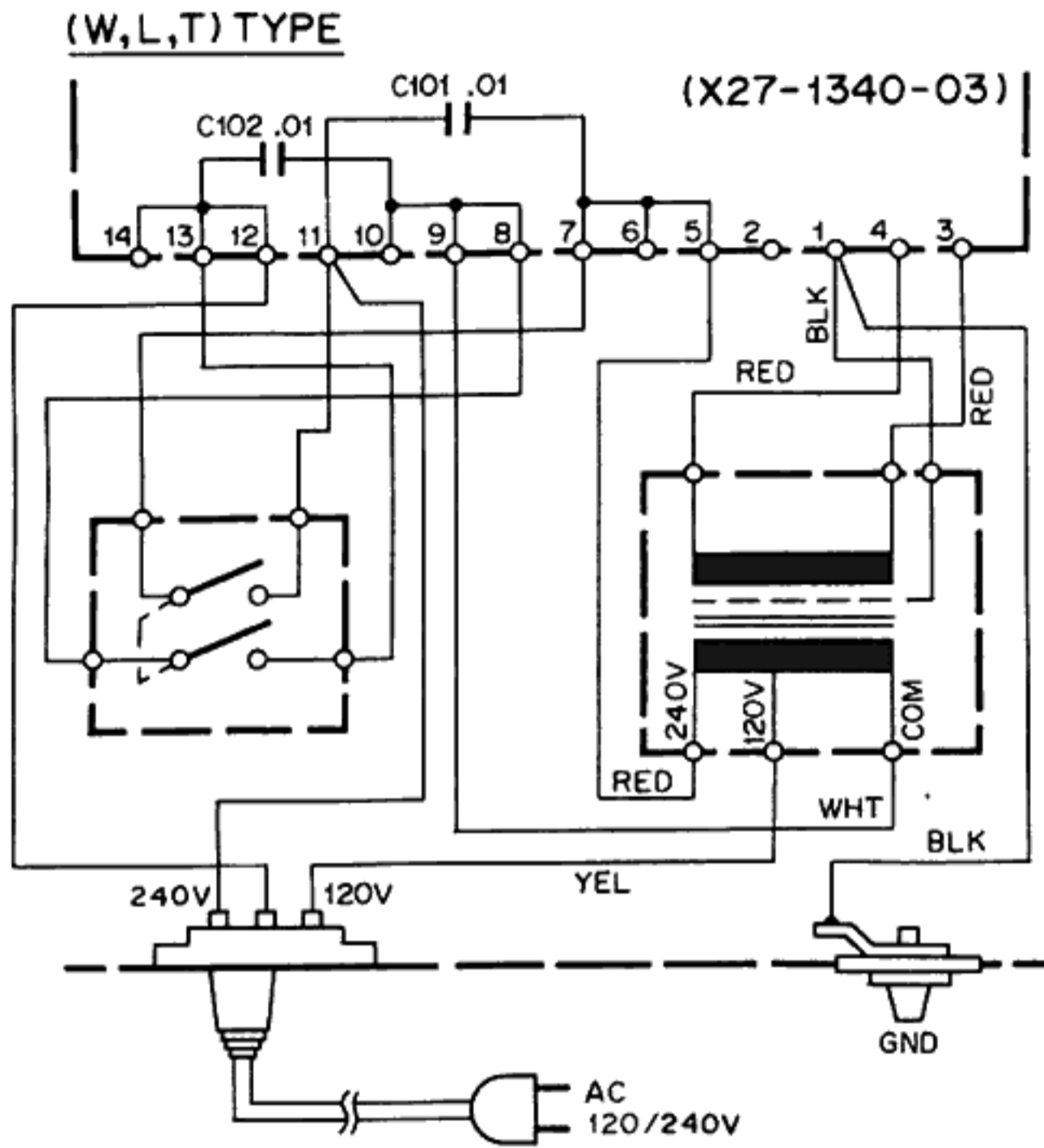

CIRCUIT/PC BOARD

POWER SUPPLY (X27-1340-01)

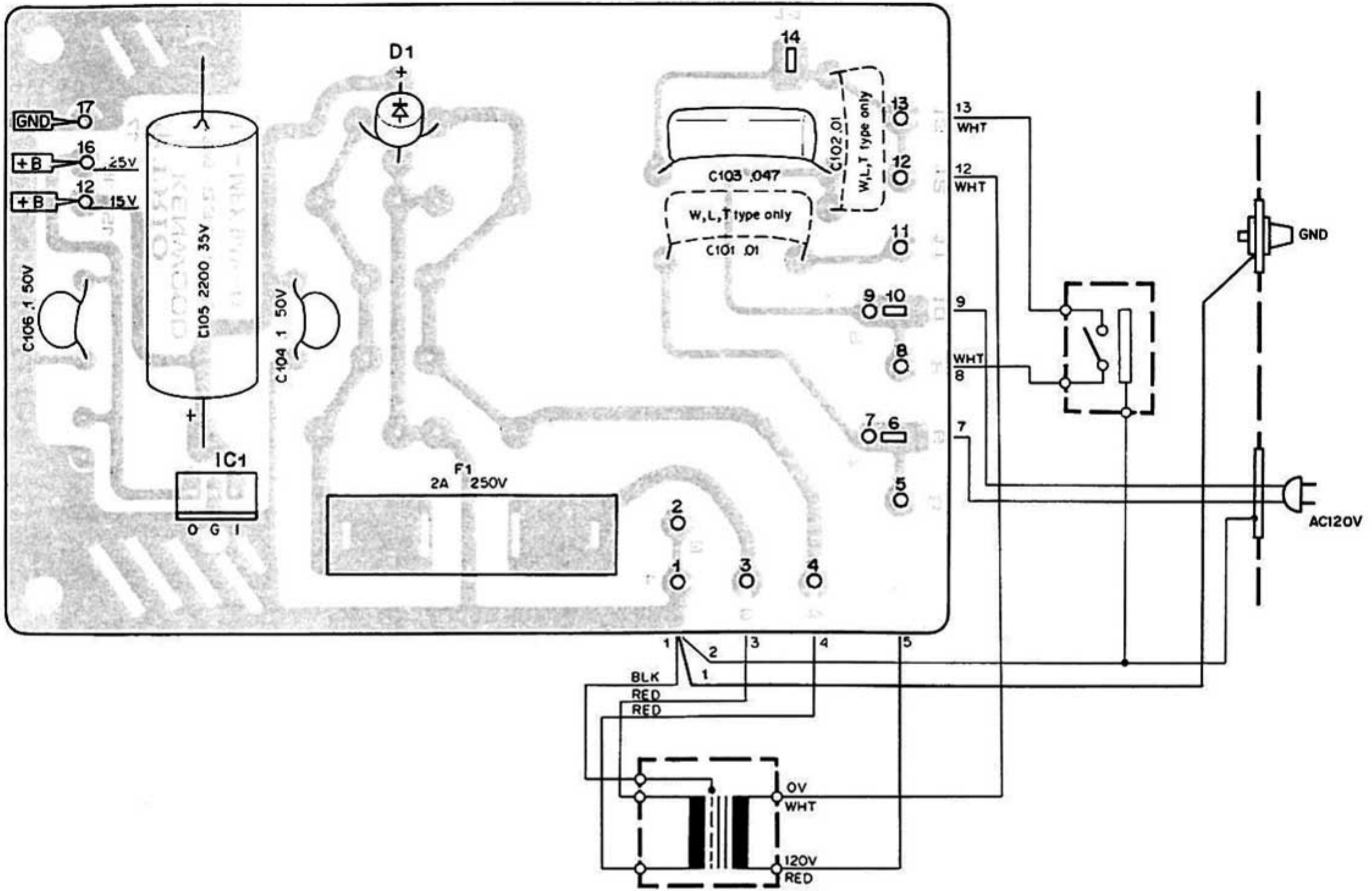

MUTING (X25-1400-00)

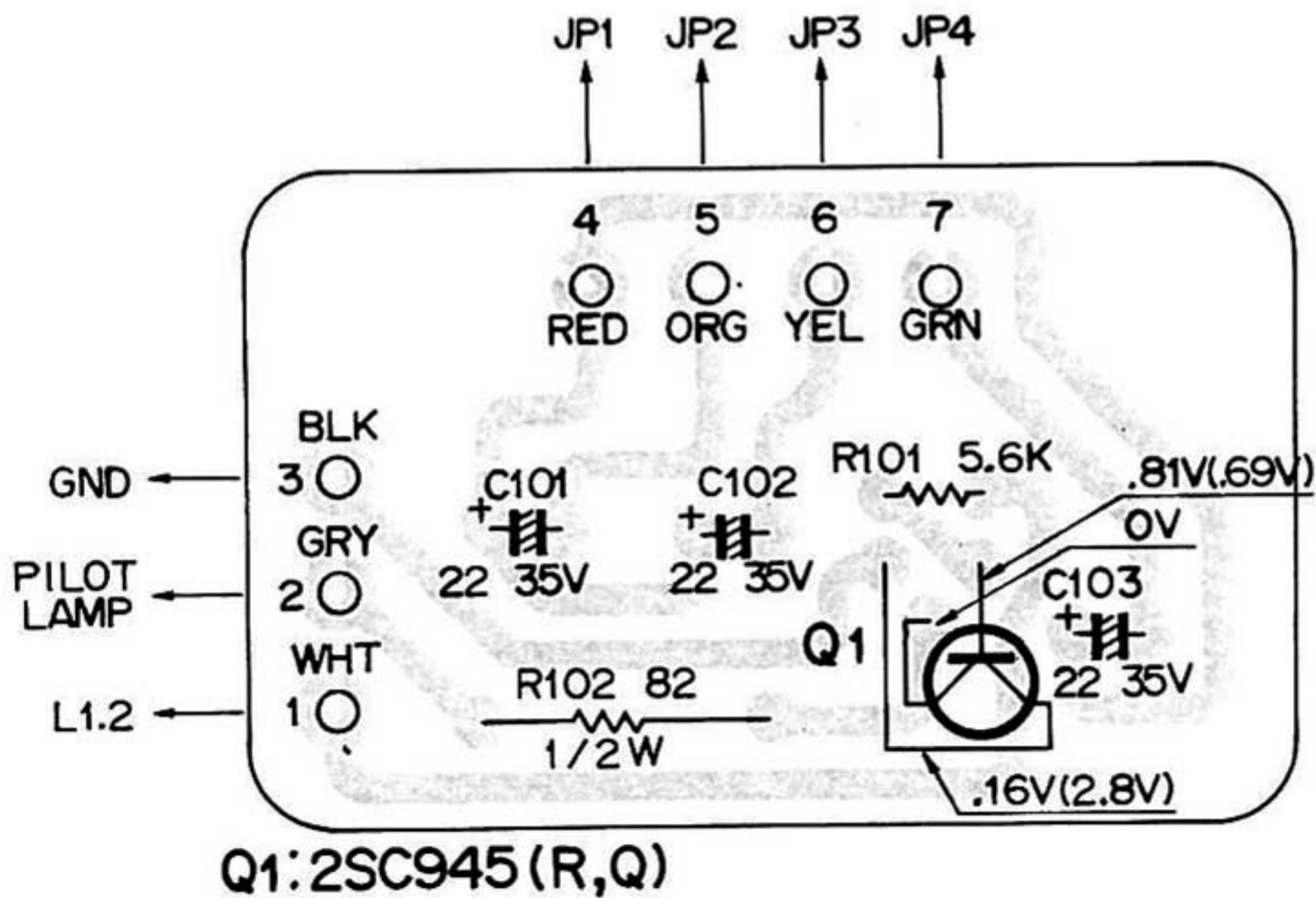

PC BOARD

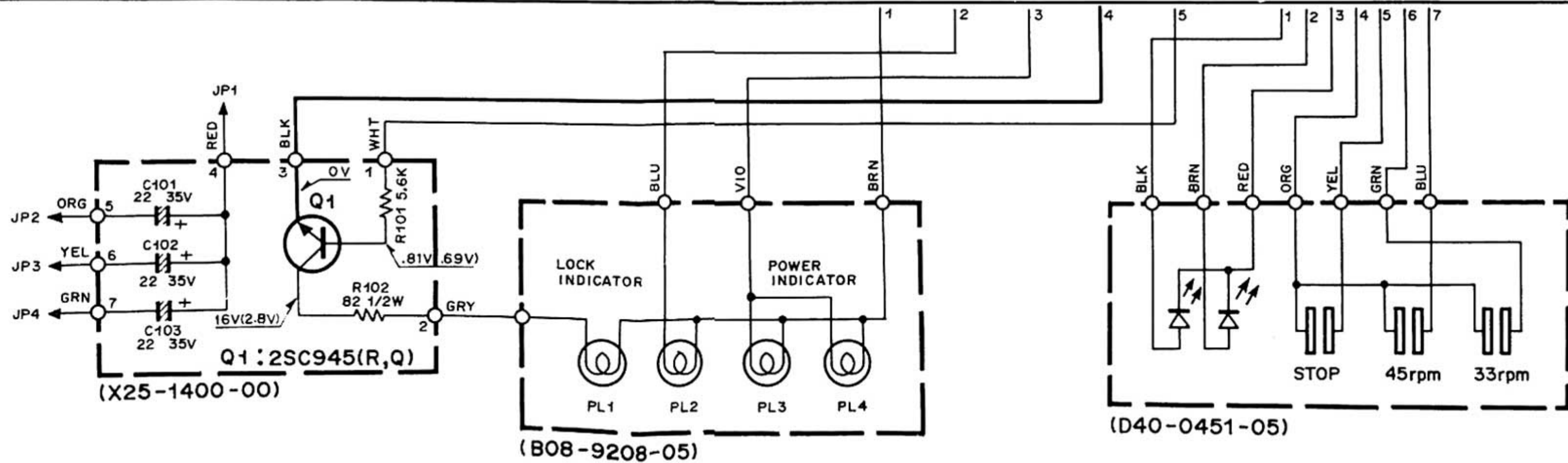
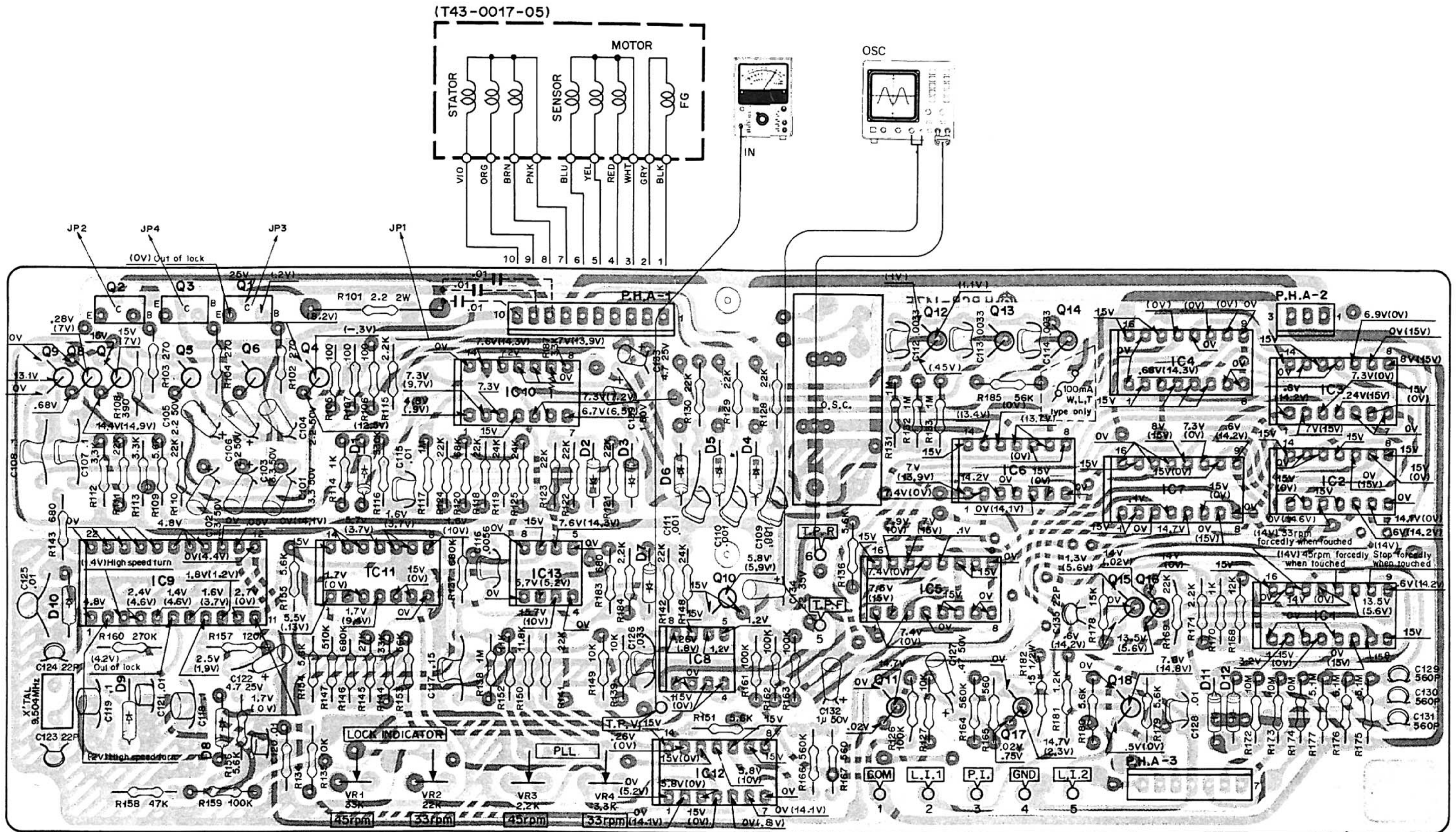

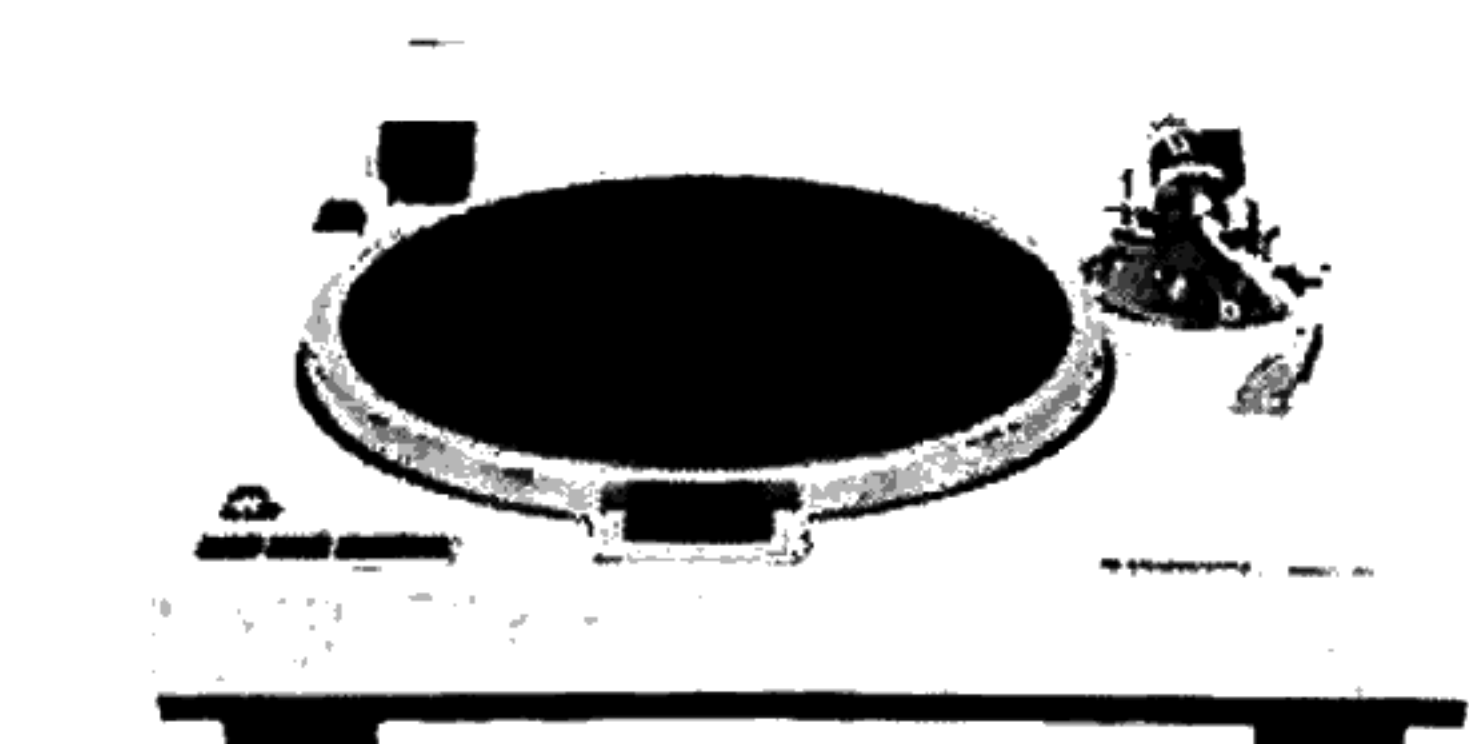


SPECIFICATIONS

MOTOR & TURNTABLE	
Drive System	Quartz PLL direct drive system
Motor	20 pole, 30 slot brushless DC servo motor (Starting torque 1.5 kg cm)
Turntable Platter	33 cm (13 inch) diameter Aluminum alloy die-cast Weight 2.6 kg (5.7 lbs.) Moment of inertia 550 g cm ²
Speeds	2 speed, 33 1/3 and 45 rpm
Wow & Flutter	Less than 0.02% (WRMS)
Signal to Noise Ratio	Less than +0.020% (DIN)
Rumble	DIN weighted better than -75 dB
Load Fluctuation	DIN unweighted better than -55 dB
Transient Load Fluctuation	0% (within 120g of tracking force) Less than 0.003% (at 33 1/3 rpm, 400 Hz, 20 g/cm load) Less than 0.0015% (at 33 1/3 rpm, 1,000 Hz, 20 g/cm load)
Starting Time	Within 1.8 sec
Platter Speed Deviation	Less than 0.002%
Time Drift	Less than 0.002 s/h
Temperature Drift	Less than 0.0002 %/°C
TONEARM (KD-650)	
Type	Static-balanced type S-shoof pipe arm, EIA plug in connector
Effective Tonearm Length	245 mm (9 5/8 inch)
Overhang	15 mm (9/16 inch)
Tracking Error	+1.8 to -1.0 degree
Stylus Pressure Variable Range	0 to 3 gram, 10.1 g step
Usable Cartridge Weight	2.0 to 12.0 grams
Adjustable Height Range	Within +3 mm (1/8 inch)
Arm Base	Wedge-shaped chuck type
CARTRIDGE (KD-650)	
(Only military's model is equipped with the DM 11 cartridge.)	
Furnished Cartridge	DM 11
Stylus	N-11
Frequency Response	20 Hz to 20,000 Hz
Output Voltage	3.5 mV (1,000 Hz, 5 cm/sec)
Optimum Tracking Force	2.0 to 3 grams
Lead Immersion	50 kohms
Channel Separation	Better than 27 dB (1,000 Hz)
Replacement Stylus	N-11
ADDITIONAL FEATURES	
	Illuminated quartz lock and power indicator
	Electronic controlled brake
	Digital sensor start and stop switches
	LED speed indicators
	Adjustable height insulators
	Acrylic dust cover (weight 1.2 kg)
	Headrest stand
	Helicoid type arm height adjuster
	Wedge-shaped chuck type arm base
	Static type anti-skating device
	Oil-damped overing device
	Stylus pressure direct readout counter
MISCELLANEOUS	
Power Requirement	AC 120V, 60 Hz U.S.A., Canada model AC 240V, 50 Hz U.K. model AC 120V/240V (switchable), 50 Hz Australia model AC 120V/220V (switchable), 50Hz/60 Hz, Others
Power Consumption	35.0 watts
Dimensions	W 490 mm (19 5/16") H 166 mm (6 5/8") D 458 mm (18 1/4")
Weight	KD-650 16.0 kg (35.2 lbs.) KD-600 15.4 kg (33.9 lbs.)
SUPPLIED ACCESSORIES	
	45 rpm adaptor with overhang gauge, Screw driver, Silicon cloth, Ground wire
	Hexagonal wrench, Two tonearm bases for SMC 3009/3008/3009-III and 18F18TV black wood or ORYFON AS 212MKII
CABINET	
Material	Construction of cabinet is anti-resonance compression base (ARCB) with hard homogenized board. This massive ARCB is compression molded from lime-stone particles, glass powder and lime-stone based and unsaturated polyester resin.
Cabinet Airy Weight	7.8 kg (17.4 lbs.)
ARCB Weight	6.5 kg (14.3 lbs.)
Note: Kenwood follows a policy of continuous advancement in development. For this reason specifications may be changed without notice.	

- | | | | | | | | | | | |
|---------|--------|---------|------------|--------|---------|---------|---------|-----------|--------|-----------|
| 2SA733 | 2SD793 | SN16889 | SM6415A-4S | CA324G | SAS560S | CA741CG | CD4001 | CD4066 | CD4027 | μPC78M15H |
| 2SC945 | | | | | | | CD4011 | MM74C906N | CD4049 | |
| 2SC2003 | | | | | | | CD40106 | | | |
-

DC voltage measured with 20 kΩ/V VOM under 33-1/3 rpm
() means STOP condition.

WAVEFORMS AT CHECK POINTS

Note:
When connecting a oscilloscope to every check points, use the probe 10:1, having a 10 M Ω impedance.

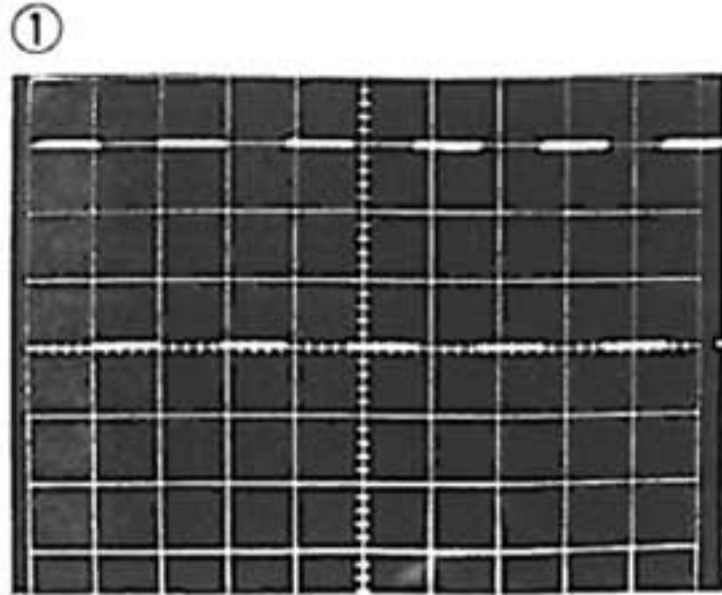

①
5 mS/cm, .5 V/cm, DC coupled:
Confirm FG signal.

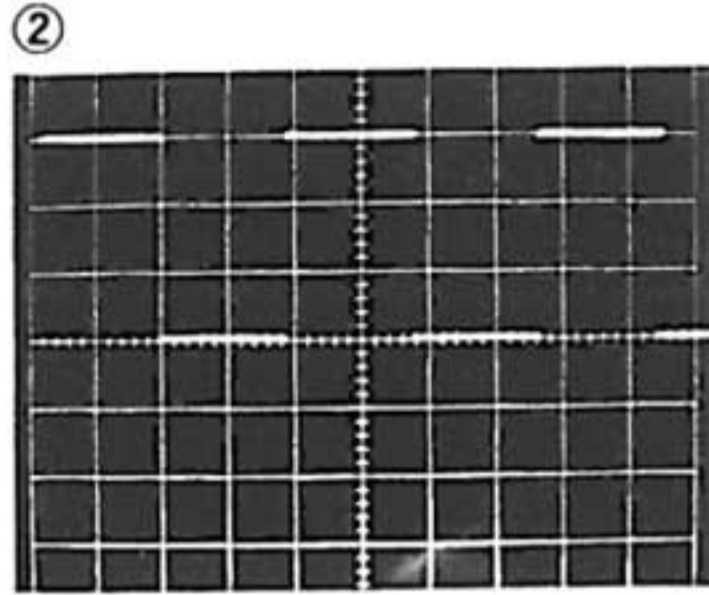

②
5 mS/cm, .5 V/cm, DC coupled:
Confirm FG signal

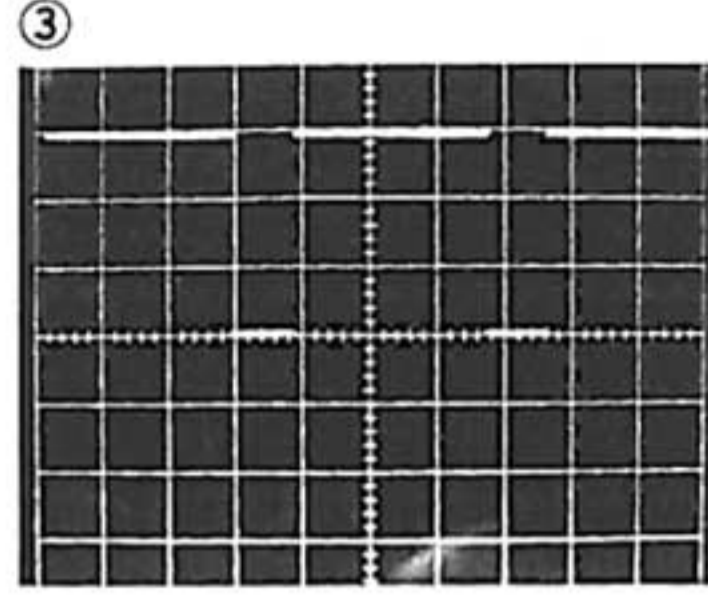

③
5 mS/cm, .5 V/cm, DC coupled:
Confirm lock indicator circuitry.

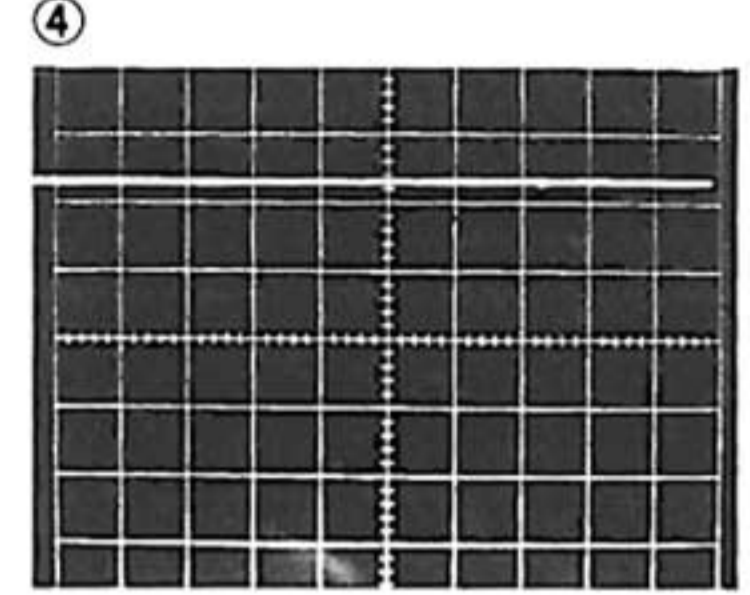

④
5 mS/cm, .5 V/cm, DC coupled:
Confirm Zener diode D1.

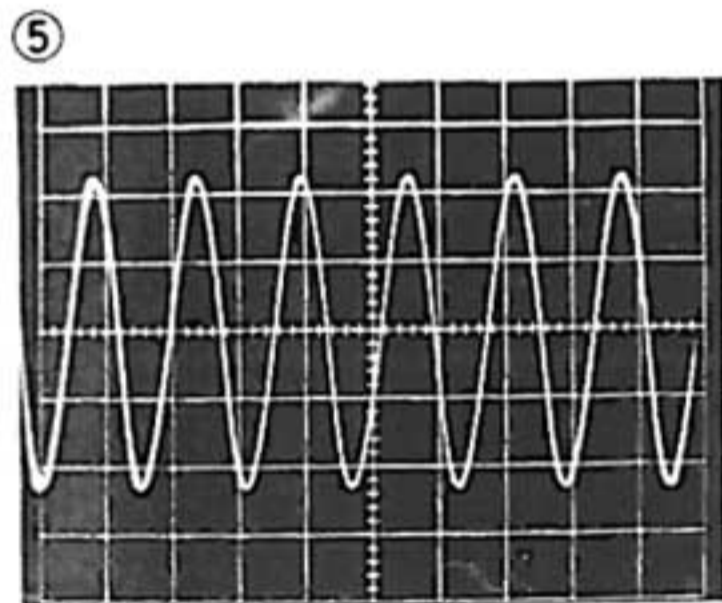

⑤
10 μ s/cm, .1V/cm, AC coupled:
Confirm OSC block (60 kHz, 5Vp-p)

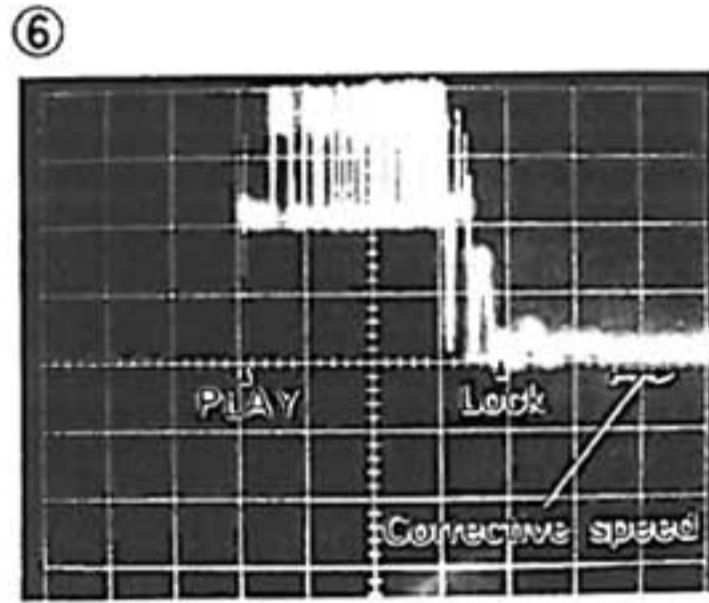

⑥
.5 μ S/cm, .5 V/cm, DC coupled:
Confirm motor-circuitry and -turning
132 mV (MAX) is generated when
turning the turntable platter.

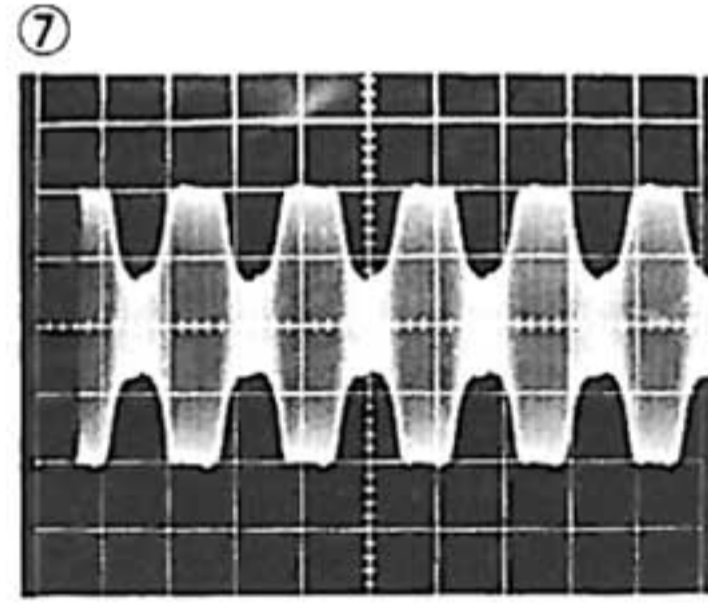

⑦
.1 S/cm, .1 V/cm, AC coupled:
Confirm sensor of motor.

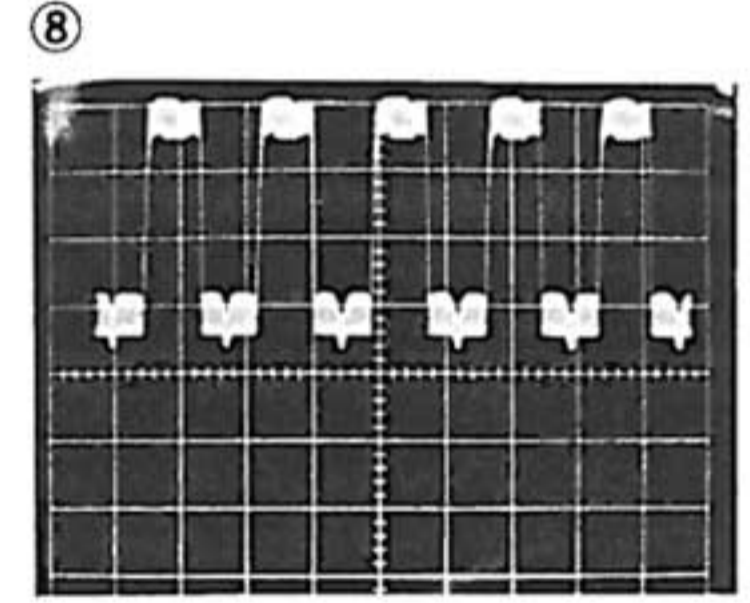

⑧
.1 S/cm, .2 V/cm DC coupled.
Confirm turning-direction detection
circuit

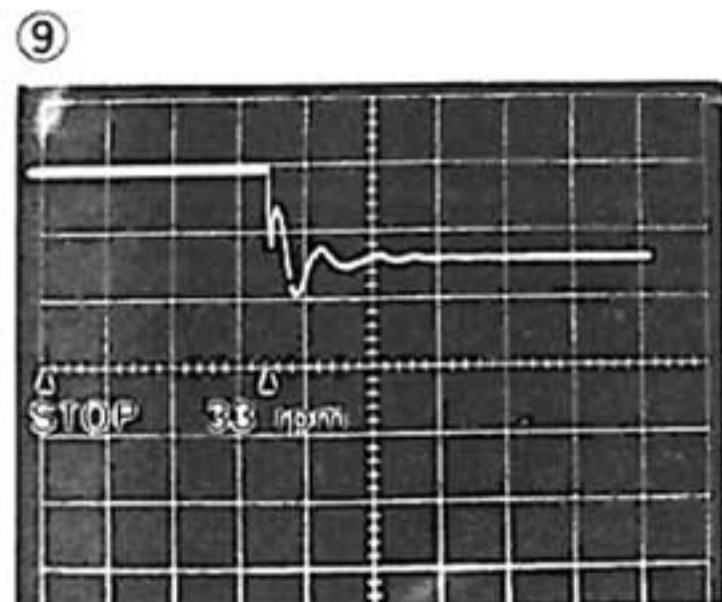

⑨
.5 S/cm, .5 V/cm DC coupled
Confirm control circuitry.

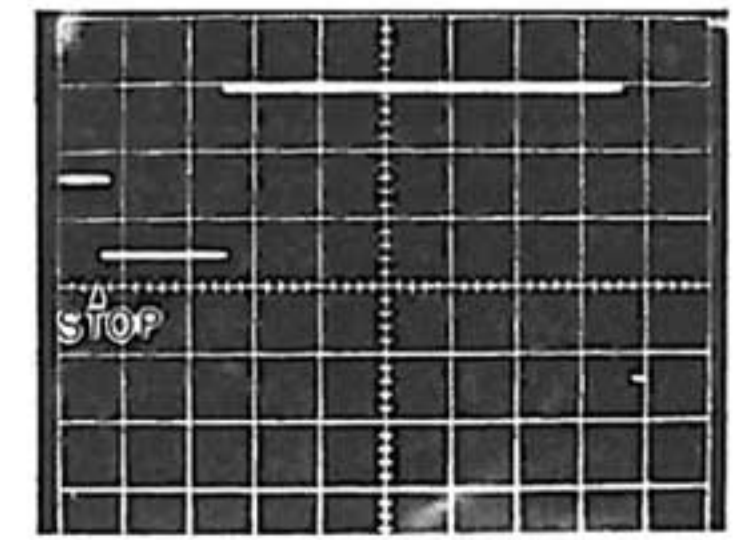
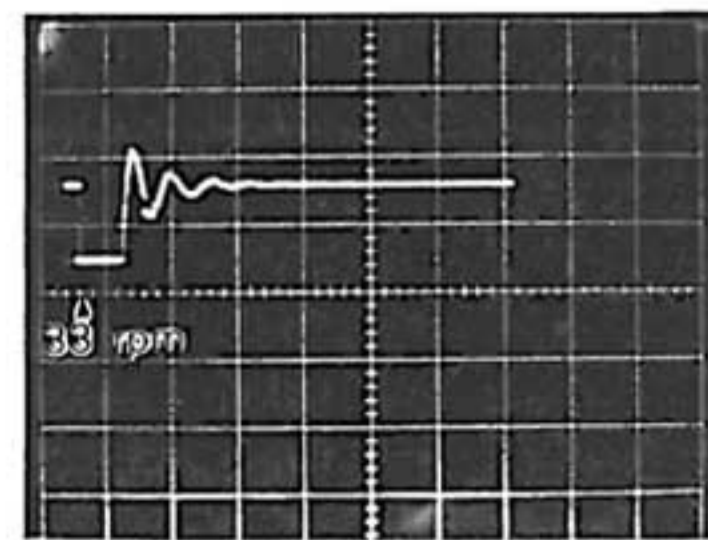
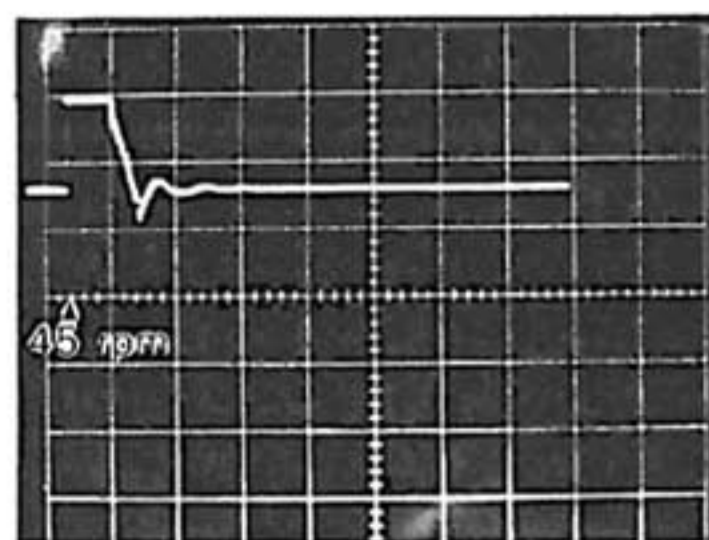

⑩

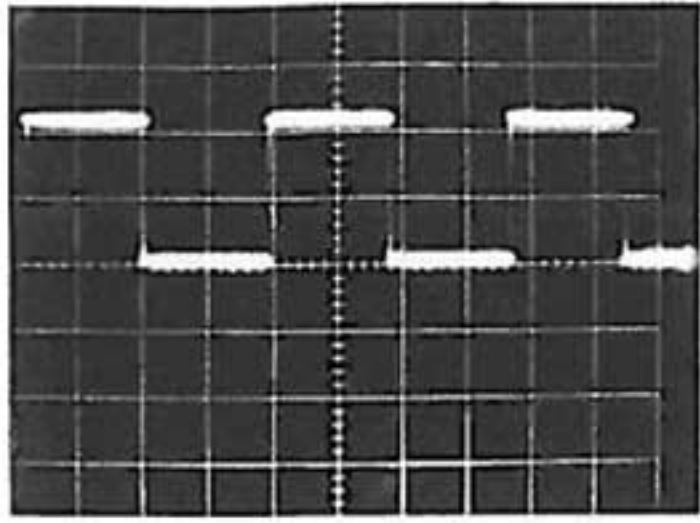

5 mS/cm, .2 V/cm DC coupled:
Confirm input signal to SM6415A.

⑪

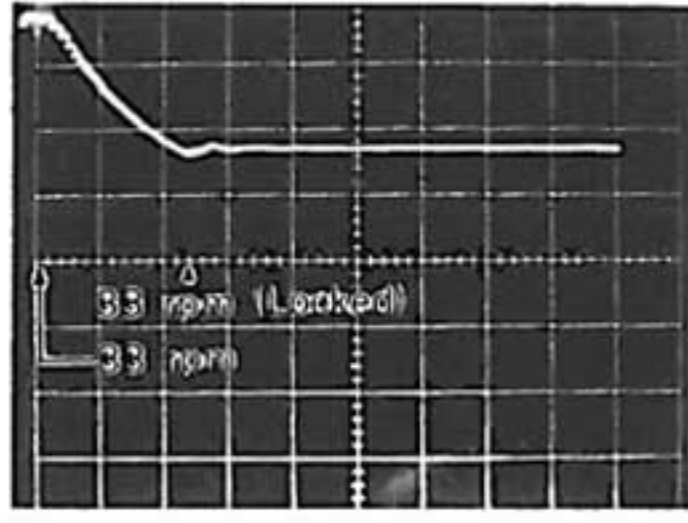

0.5 mS/cm, .1 V/cm DC coupled:
Confirm S-V converter output

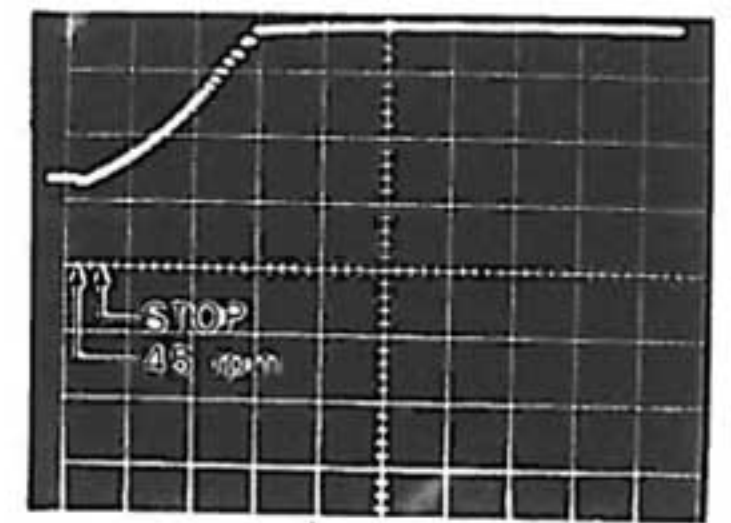
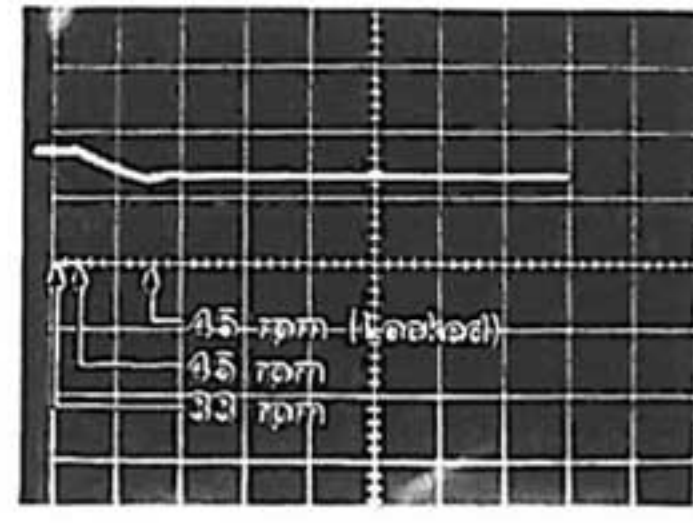

⑫

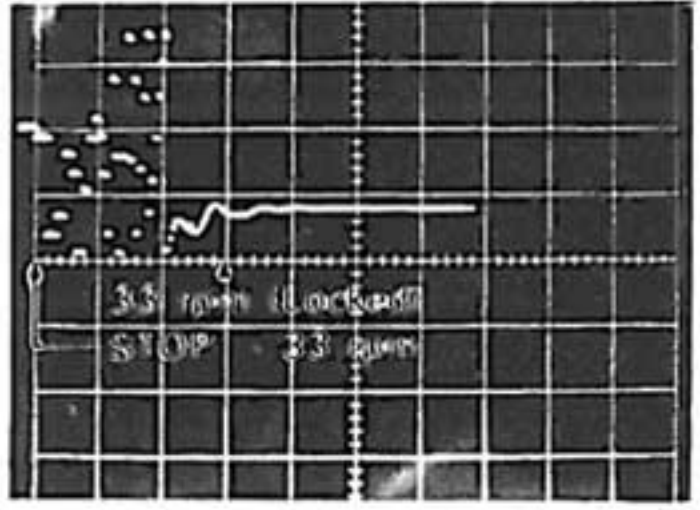

0.5 mS/cm, .1 V/cm DC coupled.
Confirm P-D detector output

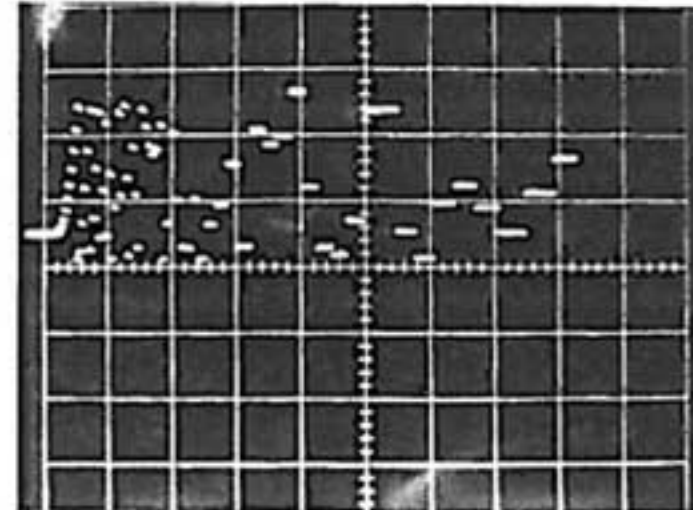
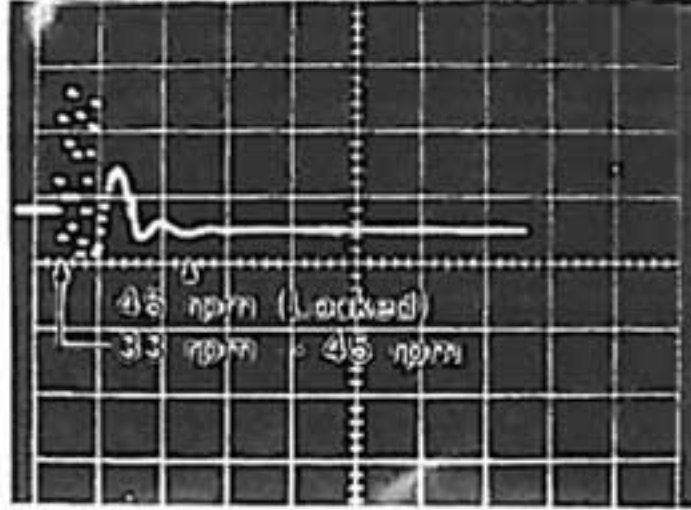

⑬



5 mS/cm, .1V/cm DC coupled:
Confirm S-V converter operation

⑭

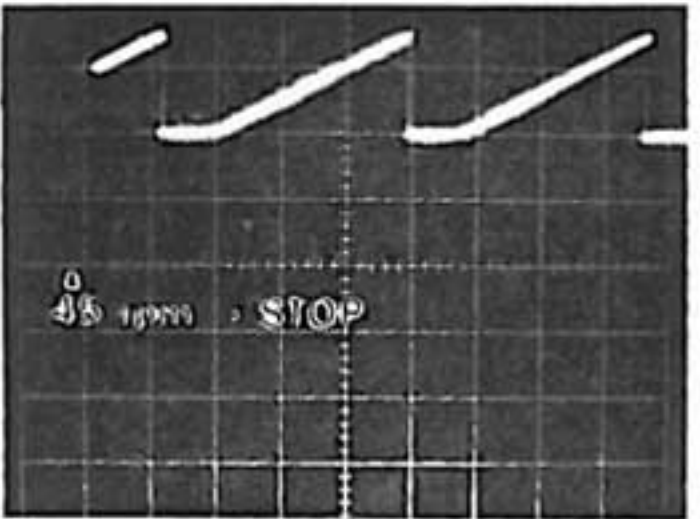

5 mS/cm, .2V/cm DC coupled.
Confirm P-D detector operations.

A product of

TRIO-KENWOOD CORPORATION

6-17, 3-chome, Aobadai, Meguro-ku, Tokyo 153, Japan

KENWOOD ELECTRONICS, INC.

1315 E. Watsoncenter Rd. Carson, California 90745
75 Seaview Drive, Secaucus, New Jersey 07094, U.S.A.

TRIO-KENWOOD ELECTRONICS, N.V.

Leuvensesteenweg 184 B-1930 Zaventem, Belgium

TRIO-KENWOOD ELECTRONICS GmbH

Rudolf-Braas-Str. 20, 6056 Heusenstamm, West Germany

TRIO-KENWOOD FRANCE S.A.

5, Boulevard Ney, 75018 Paris, France

TRIO-KENWOOD SVENSKA AB

Kemistvagen 10A, S-183 21 Taby, Sweden

TRIO-KENWOOD (AUSTRALIA) PTY. LTD.

30 Whiting St., Artarmon, N.S.W. 2064, Australia

KENWOOD & LEE ELECTRONICS, LTD.

Room 501, Wang Kee Building, 5th Floor, 34-37, Connaught Road, Central, Hong Kong

Free Manuals Download Website

<http://myh66.com>

<http://usermanuals.us>

<http://www.somanuals.com>

<http://www.4manuals.cc>

<http://www.manual-lib.com>

<http://www.404manual.com>

<http://www.luxmanual.com>

<http://aubethermostatmanual.com>

Golf course search by state

<http://golfingnear.com>

Email search by domain

<http://emailbydomain.com>

Auto manuals search

<http://auto.somanuals.com>

TV manuals search

<http://tv.somanuals.com>