

# KENWOOD

## **Document Copyrights**

Copyright 2006 by Kenwood Corporation. All rights reserved.

No part of this manual may be reproduced, translated, distributed, or transmitted in any form or by any means, electronic, mechanical, photocopying, recording, or otherwise, for any purpose without the prior written permission of Kenwood.

## **Disclaimer**

While every precaution has been taken in the preparation of this manual, Kenwood assumes no responsibility for errors or omissions. Neither is any liability assumed for damages resulting from the use of the information contained herein. Kenwood reserves the right to make changes to any products herein at any time for improvement purposes.

# TKR-901

## SERVICE MANUAL

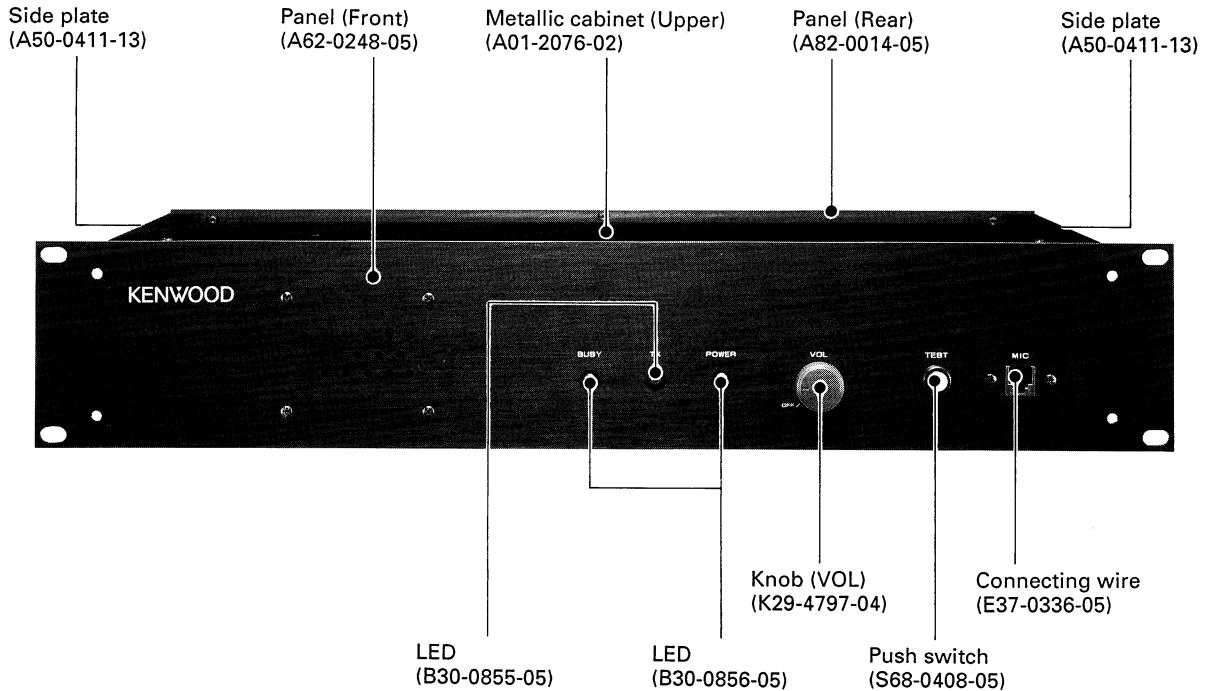

## CONTENTS

GENERAL .....	2	PACKING .....	28
OPERATING FEATURES .....	3	ADJUSTMENT .....	29
INSTALLATION .....	6	CHANNEL FREQUENCY CHART .....	33
BLOCK DIAGRAM .....	7	PC BOARD VIEWS	
CIRCUIT DESCRIPTION .....	8	RX UNIT (X55-3020-11) .....	37
SEMICONDUCTOR DATA .....	12	TX UNIT (X56-3020-11) .....	39
DESCRIPTION OF COMPONENTS .....	14	SCHEMATIC DIAGRAM .....	41
PARTS LIST .....	16	TERMINAL FUNCTION .....	44
EXPLODED VIEW .....	27	SPECIFICATIONS .....	BACK COVER

# TKR-901

## GENERAL

### INTRODUCTION

#### SCOPE OF THIS MANUAL

This manual is intended for use by experienced technicians familiar with similar types of commercial grade communications equipment. It contains all required service information for the equipment and is current as of the publication data. Changes which may occur after publication are covered by either Service Bulletins or Manual Revisions. These are issued as required.

#### ORDERING REPLACEMENT PARTS

When ordering replacement parts or equipment information, the full part identification number should be included. This applies to all parts : components, kits, or chassis. If the part number is not known, include the chassis or kit number of which it is a part, and a sufficient description of the required component for proper identification.

### PERSONNEL SAFETY

The following precautions are recommended for personnel safety :

- DO NOT transmit until all RF connectors are verified secure and any open connectors are properly terminated.
- SHUT OFF and DO NOT operate this equipment near electrical blasting caps or in an explosive atmosphere.
- This equipment should be serviced by a qualified technician only.

### SERVICE

This radio is designed for easy servicing. Refer to the schematic diagrams, printed circuit board views, and alignment procedures contained within.

### NOTE

WE CANNOT guarantee oscillator stability when using channel element manufactured by other than KENWOOD or its authorized agents.

### FCC COMPLIANCE AND TYPE NUMBERS

Type acceptance number	Frequency range	Compliance
ALHTKR-901-1	935~940MHz	Part 90

### 1. Overview

The TKR-901 is an 900-MHz-band trunking repeater system radio unit.

### 2. Main Features

- LTR® repeater system can be used by connecting the TKR-901 to the trunking logic controller.
- LTR® is registered trademark of E.F Johnson Co.
- 19-inch rack size fits into any 19-inch cabinet.
- Use of the frequency synthesizer and setting of FCC channels (1 to 399 channels) makes it easy to set frequencies.

## OPERATING FEATURES

### 1. Controls and Functions

#### 1-1. Front panel

- ① Speaker  
Used to output and monitor receive signals.
- ② BUSY indicator  
Lights when the receiver channel is in use. It blinks if a receiver failure occurs.
- ③ TX indicator  
Lights during transmission. It blinks if a transmitter failure occurs.
- ④ POWER indicator  
Lights while the repeater unit is energized. It blinks if an error occurs in repeater operation.
- ⑤ Volume control  
Used to adjust the output level of the monitor speaker.  
Normally set the control to the "off" position.
- ⑥ TEST switch  
Used as a transmission test switch.
- ⑦ MIC connector  
Used to connect with a **dynamic microphone** (use the optional microphone KMC-14). This connector is not used during repeater operation.

#### 1-2. Rear panel

- ⑧ TX OUT connector  
Used to output transmitter drive signals to the external RF amplifier.
- ⑨ LOGIC INTERFACE connector  
Used to connect the external logic control section.
- ⑩ RX ANT connector  
Used to connect the external RX ANT unit.
- ⑪ DC input connector  
Used to input 13.8V DC.
- ⑫ FUSE holder  
This holds a 3-A fuse.

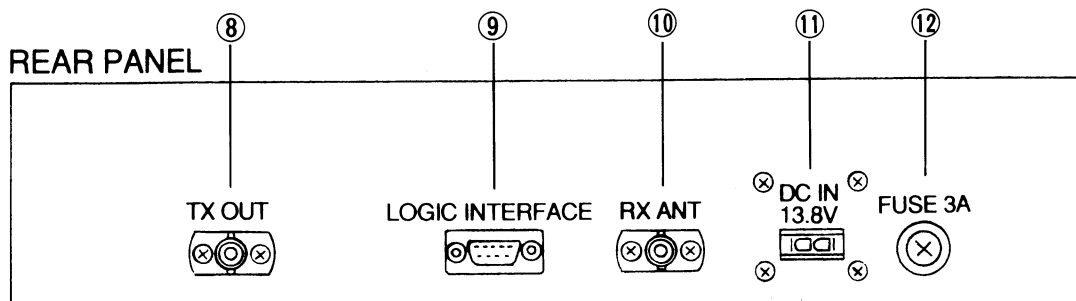
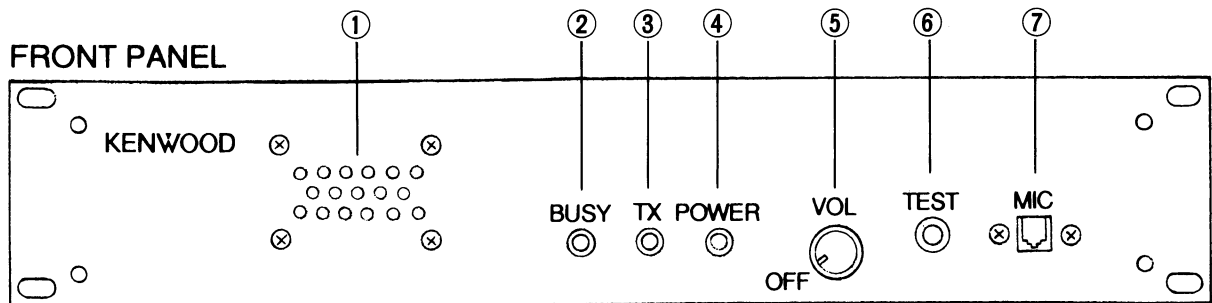

## OPERATING FEATURES

### 2. Logic Interface Connector (J304) Pins

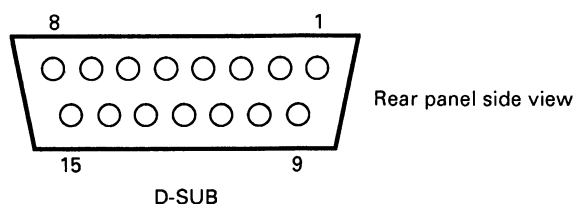

- ① NC  
Not used
- ② NC  
Not used
- ③ E  
Earth
- ④ NC  
Not used
- ⑤ RA (RX Audio Signal Output)  
This port outputs the AF signal passing through the AF band-pass filter in the receiver. The port can be used to check the receiver performance. The output level is about 400mVrms. (High impedance)
- ⑥ NC  
Not used
- ⑦ TA (TX Modulation Signal Input)  
This port inputs the modulation signal for repeater operation. The input level is 140mVrms (600Ω) and a 1-kHz AF signal causes 0.75kHz deviation.
- ⑧ MN (Monitor Switch)  
This port is used for the monitor switch. When it goes low, the preset squelch opens.
- ⑨ E (RX Earth)  
RX ground  
This ground is used when the RA pin (pin 5) and RD pin (pin 15) are used.
- ⑩ SQ (Squelch Signal)  
This signal indicates whether the unit is busy or not.  
High : Busy

- ⑪ PT1 (PTT Signal Input)  
This port is a PTT switch for repeater operation. When it goes low, the PTT turns on and transmission mode is entered.
- ⑫ T12 (10 voltage output)  
Transmission voltage (about 9.5V) is output during transmission.
- ⑬ TD (TX Tone Signal Input)  
This port inputs the sub-audio signal (DC to 300Hz) to operate the repeater. The input level is 0.5Vp-p (600Ω) and the AF signal (100Hz) causes a 0.75-kHz deviation.
- ⑭ E (TX Earth)  
TX ground  
This ground is used when the TA pin (pin 7) and TD pin (pin 13) are used.
- ⑮ RD (RX Detector Signal Output)  
This port is for the receive detection output signal to operate the repeater. The output level is 80mVrms (50kΩ).

### 3. Repeater Operation

Repeater operation is possible by supplying 13.8V DC to the power supply of the main unit and connecting the logic controller to the logic interface connector. (LTR® trunking system) When repeater operation is performed (link), the Busy LED (receive mode) and TX LED (transmit mode) light. If you want to monitor during repeater operation, turn the volume control clockwise.

### 4. Transceiver Operation

#### 4-1. Reception

13.8V is applied to DC IN.

When an incoming signal from the RX ANT matches the desired signal, the Busy LED lights. If the Busy LED flashes, something is wrong with receiver operation.

#### 4-2. Transmission

13.8V is applied to DC IN.

Transmit mode is entered and the TX LED lights when the PTT signal is output from the logic interface or the TEST pin is pressed. If the TX LED flashes, something is wrong with transmitter operation.

## OPERATING FEATURES

### 5. Setting FCC Channels

**Note :** The receive channel must be the same as the transmit channel. Switch the power off before performing steps 1 to 3.

1. Remove the six screws (①) holding the top part of the radio case, and remove the top part of the case.
2. Remove the six screws (②) holding the top part of the RX unit (X55-3020-11) case, and remove the top part of the case.
3. Remove the top part of the TX unit (X56-3020-11) case (③).
4. Apply 13.8V DC to the DC IN socket on the rear panel.
5. Turn S201 (100th digit), S202 (10th digit), and S203 (1st digit) in the RX unit and the TX unit with a screwdriver to set the desired channel. The channel operation for FCC repeater operation are listed in "Adjustment".
6. For example, to set channel 123, set S201, S202, and S203 as follows:

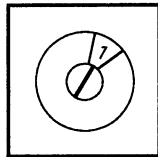

S201  
(100th digit)

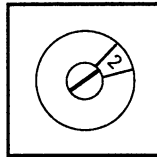

S202  
(10th digit)

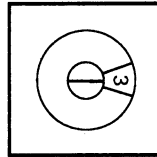

S203  
(1st digit)

7. Check the LED (D204) in the RX unit and the LED (D204) in the TX unit go off. (If they do not, the PLL is unlocked. See the PLL voltage in the adjustment procedure.)
8. Press S204 (non-locking switch) in the RX unit once. D204 in the RX unit lights, and after a while, goes off.
9. Press S204 (non-locking switch) in the TX unit once. D204 in the TX unit lights, and after a while, goes off.

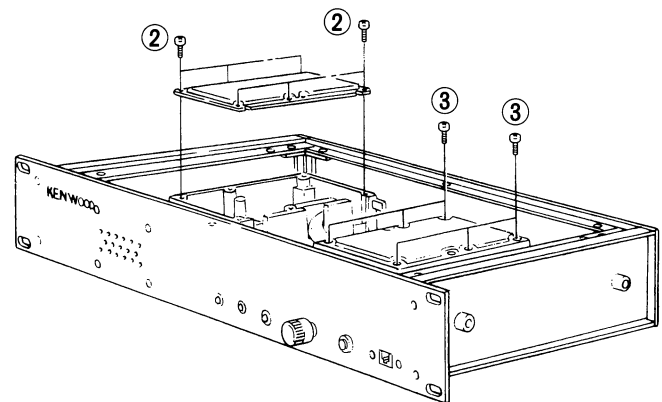
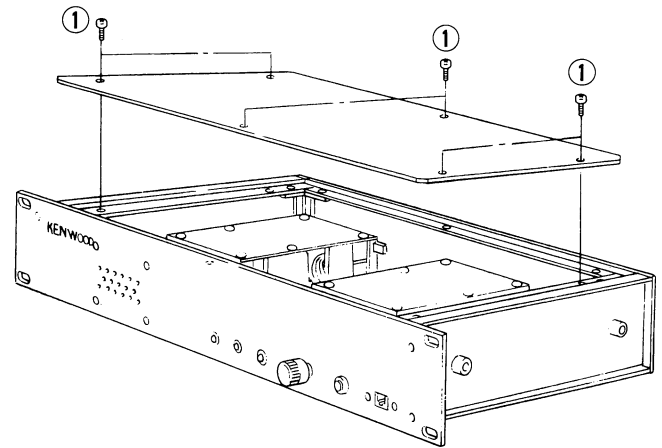

# TKR-901

## OPERATING FEATURES / INSTALLATION

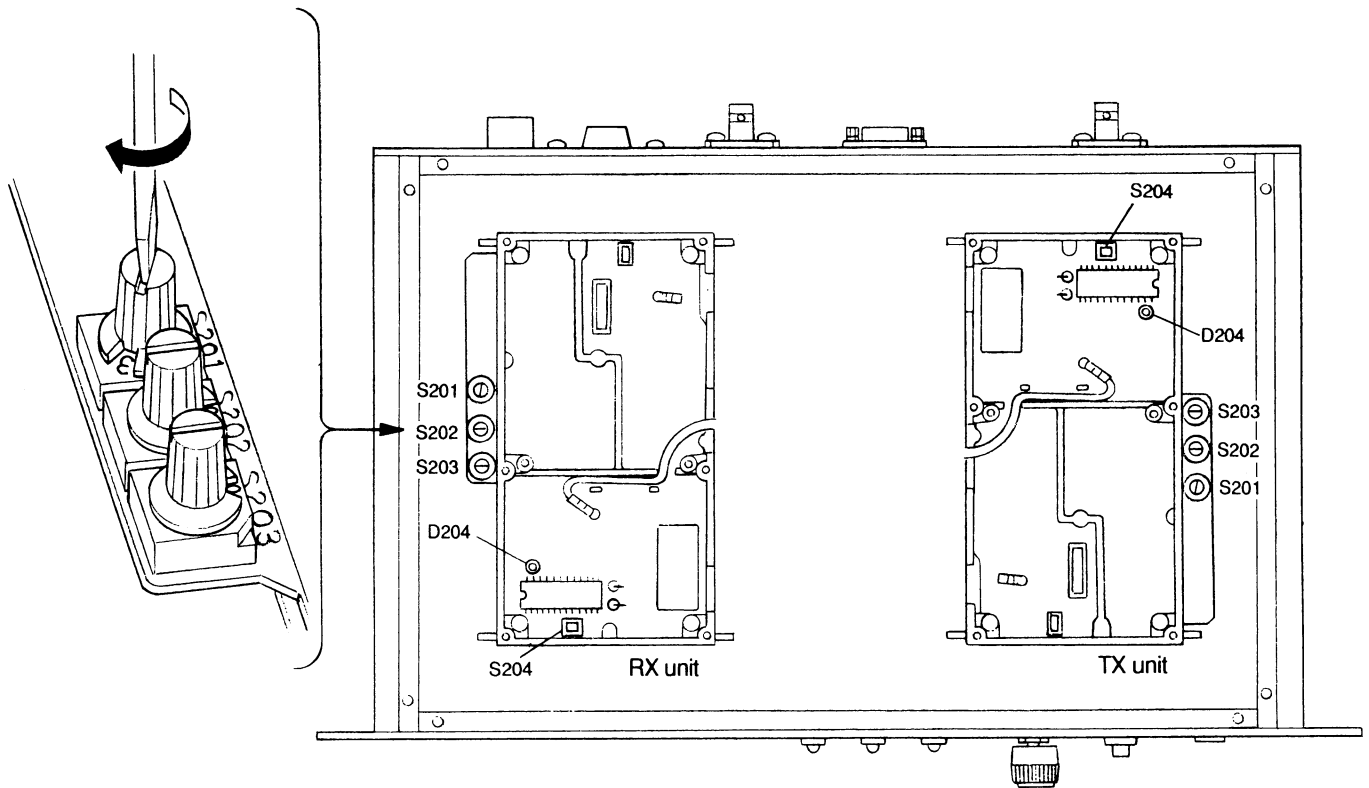

### 1. Installing the Handles (Accessories)

Install the handles with screws and washers.

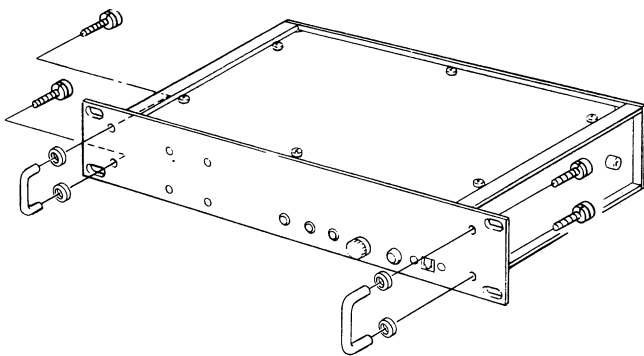

## BLOCK DIAGRAM

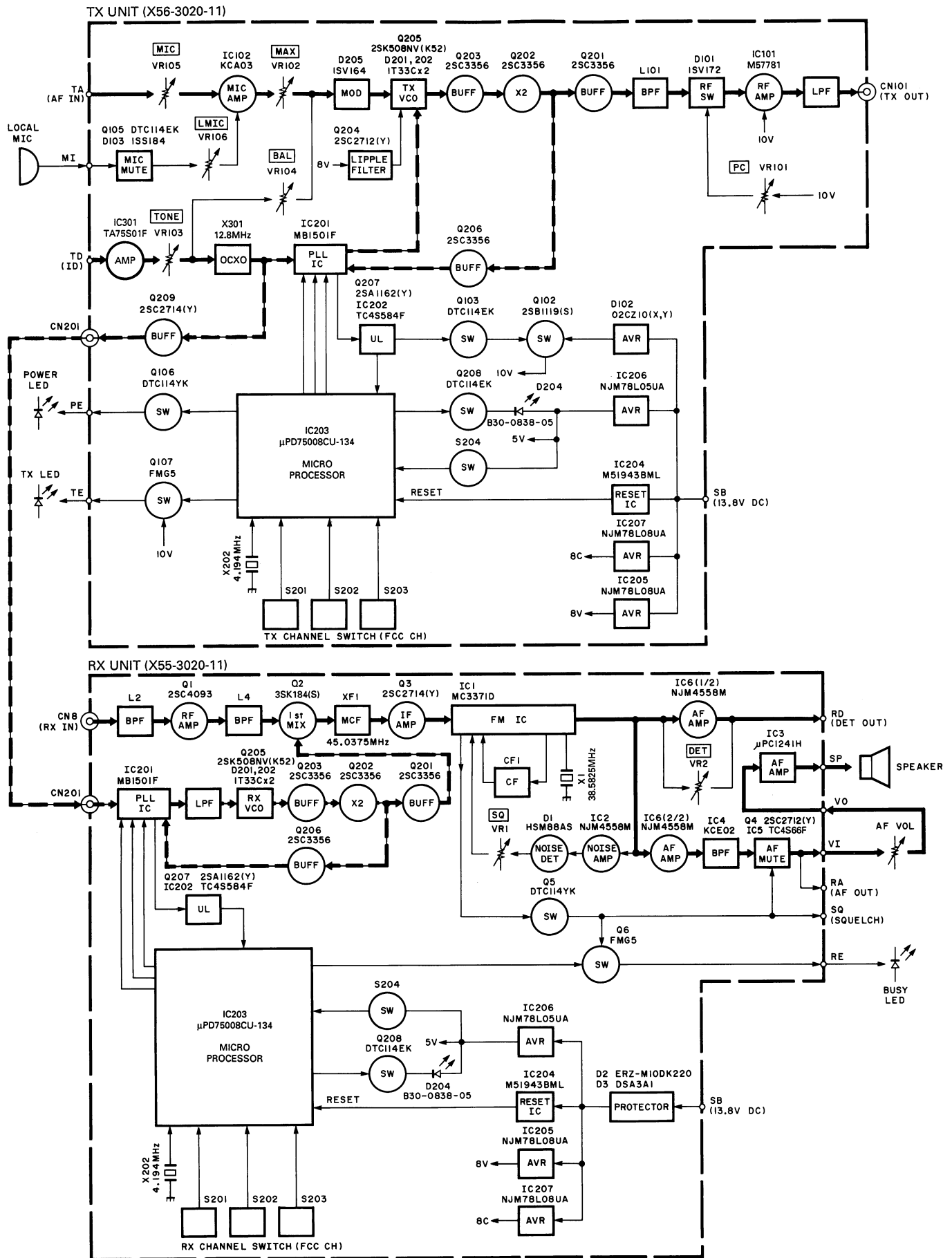



# TKR-901

## CIRCUIT DESCRIPTION

### 1. Overview

The TKR-901 is a 900-MHz-band trunking repeater system radio unit, consisting of an RX unit and a TX unit. The RX unit consists of a control section, a frequency synthesizer section (PLL), receive RF and IF sections, and a receiver audio amplifier unit. The TX unit consists of a control section, a frequency synthesizer (PLL), a transmitter microphone amplifier, and a transmitter drive amplifier section.

### 2. Receiver System

#### 2-1. RF and IF units

The receiver is a double-conversion superheterodyne designed to operate in the frequency range 896.0125 to 900.9875MHz. The RF and IF units of the receiver section consists of an RF amplifier (Q1), a first mixer (Q2), a first IF amplifier (Q3) and a second IF system IC (IC1).

An incoming RF signal through the antenna connector (CN201) is applied to a band-pass filter (L2). The

signal is then amplified by the RF amplifier (Q1) and filtered by another band-pass filter (L4). The resulting signal goes to the mixer (Q2), where it is mixed with the first local signal of the frequency synthesizer to generate the first IF signal of 39.0375MHz. The first IF signal is filtered by a four-pole crystal filter (XF1) and amplified by the first IF amplifier (Q3). The resulting signal is then applied to the second IF section.

The second IF section mainly uses on IF system IC (IC1), and consists of a second mixer, a second local oscillator, a second IF amplifier, a second IF filter, an FM detector, and a noise amplifier. The first IF signal is mixed with the second local oscillator signal (X1) of 38.5825MHz to generate the second IF signal of 455kHz. The output passes through the 455-kHz ceramic filter (CF1), and is demodulated by the quadrature-type FM detector in the limiting amplifier section in IC1. The signal is split into two: one signal is output to the receive audio amplifier section and the other is output to noise amplifier IC2 and noise detected to control the squelch signal.

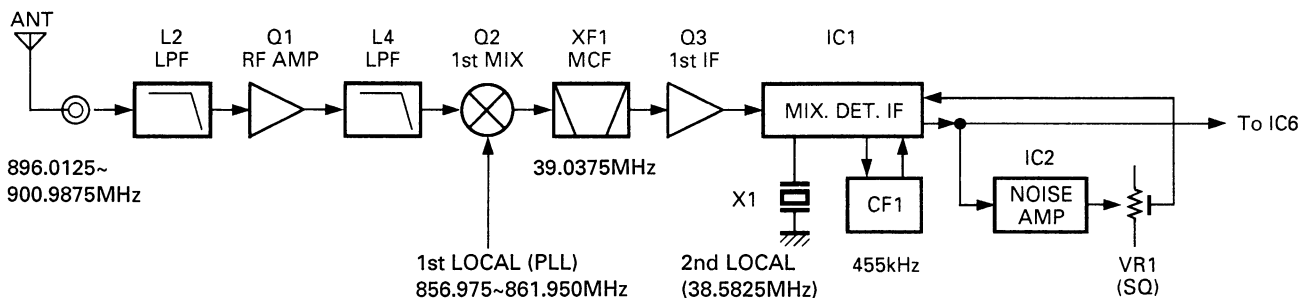

Fig. 1 Receiver system

#### 2-2. Receive audio amplifier section

One of the demodulated signals is amplified by IC6 (1/2) and output to the RD pin (CN4) as the detection output. The other signal is amplified by IC6 (2/2), and is applied to IC4. IC4 consists of a deemphasis circuit and a band-pass filter. One audio signal output from IC4 is output to the RA pin (CN4). The other passes

through the volume adjustment variable resistor, and is applied to the audio power amplifier (IC3). Here the signal is amplified to a sufficient level to drive a speaker. The audio signal output from IC4 inverts the SQ signal generated by IC1 to effect AF muting.

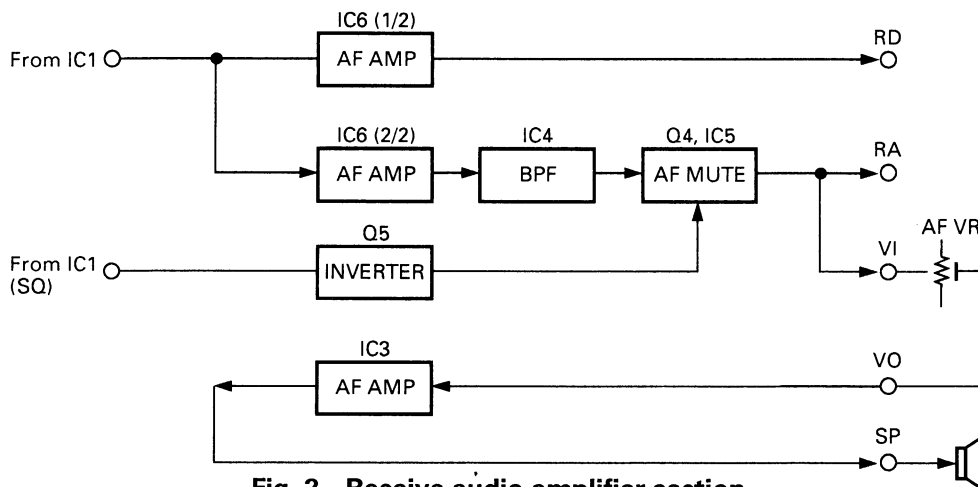

Fig. 2 Receive audio amplifier section

## CIRCUIT DESCRIPTION

### 2-3. Control section

The microprocessor sends frequency program data to the frequency synthesizer according to the receive channel data from the DIP switch (S201, S202, and S203).

The microprocessor determines whether the frequency synthesizer is locked (high). When it is locked, D204 turns off. When it is unlocked, D204 turns on, and a constant pulse signal is output to Q6 to turn it on or off. (UL indicator)

When switch S204 (non-locking type) is pressed, the microprocessor is reset, and sends frequency program data to the frequency synthesizer.

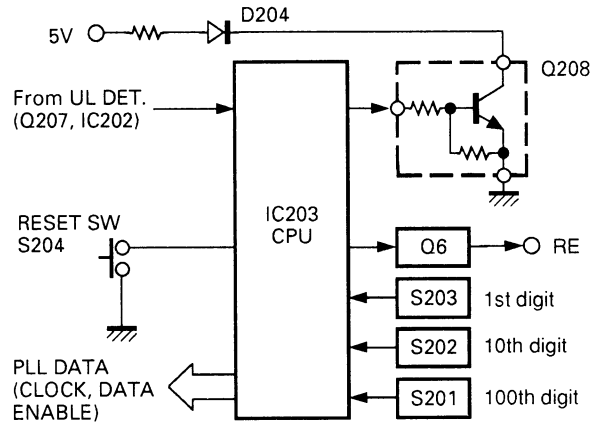

Fig. 3 RX control section

### 2-4. Frequency synthesizer section (PLL)

The frequency synthesizer section (PLL) consists of a VCO circuit, a phase-locked loop (PLL) circuit, and an unlock detection circuit. The PLL generates the first local oscillator signal for the receiver. The PLL reference signal of 12.8-MHz is supplied from the TX unit via CN201, its frequency being maintained within  $\pm 0.1$  ppm in the range  $-30$  to  $+60^\circ\text{C}$ . This signal goes to the PLL IC (IC201), and is divided by 1024 by IC201 to generate the 12.5-kHz reference signal.

The VCO is produced by Q205. The output signal from the VCO passes through the buffer amplifier (Q203) and is doubled by Q202. The RF signal is sent to two buffer amplifiers (Q201 and Q206). The output from Q201 is directed to the first mixer of the receiver circuit as the PLL output signal, and the output from

Q206 goes to the PLL IC (IC201).

The VCO signal and OCXO signal are divided according to the divide ratio data sent from the control section to generate the 12.5-kHz signal. The phase of the signal is compared with the reference signal. The phase difference signal is output from the phase comparator, passes through the charge pump and lug-reed low-pass filter, and is applied to D201 and D202 as the VCO control voltage to control the VCO frequency.

If the PLL is unlocked, the IC201 lock detect signal is converted to a DC signal by Q207 and IC202, and sent to the microprocessor in the control section. The microprocessor outputs the UL signal to Q208 and Q6. Q208 controls the LED (D204), and a pulse signal is sent to Q6 to control the external pin.

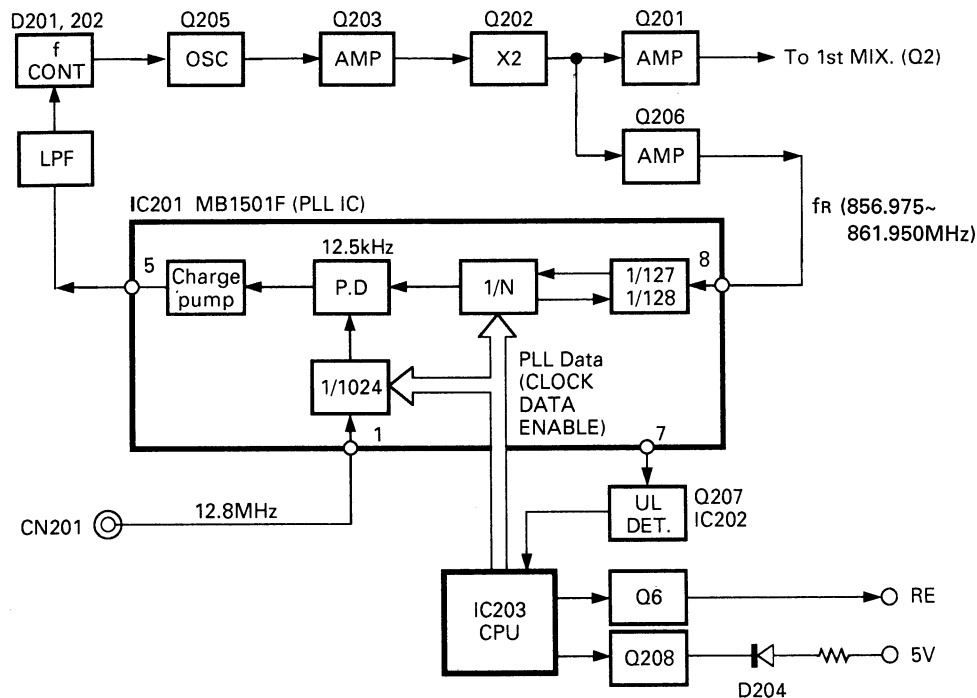

Fig. 4 RX PLL section

## CIRCUIT DESCRIPTION

### 3. Transmitter System

#### 3-1. Microphone Amplifier

The AF signal from the TA pin (CN104) goes through the microphone gain level potentiometer (VR105). The AF signal from the microphone passes through the microphone gain level potentiometer (VR106). The AF signal then goes to the microphone amplifier (IC102). IC102 consists of an amplifier, a preemphasis circuit,

and a splatter filter circuit, which has 24dB/octave characteristic. The tone encode signal input from the TD pin is amplified by IC301, and then summed with the output from IC102. The signal is applied to the modulation input of the modulator (D205) of the frequency synthesizer and the OCXO (X301).

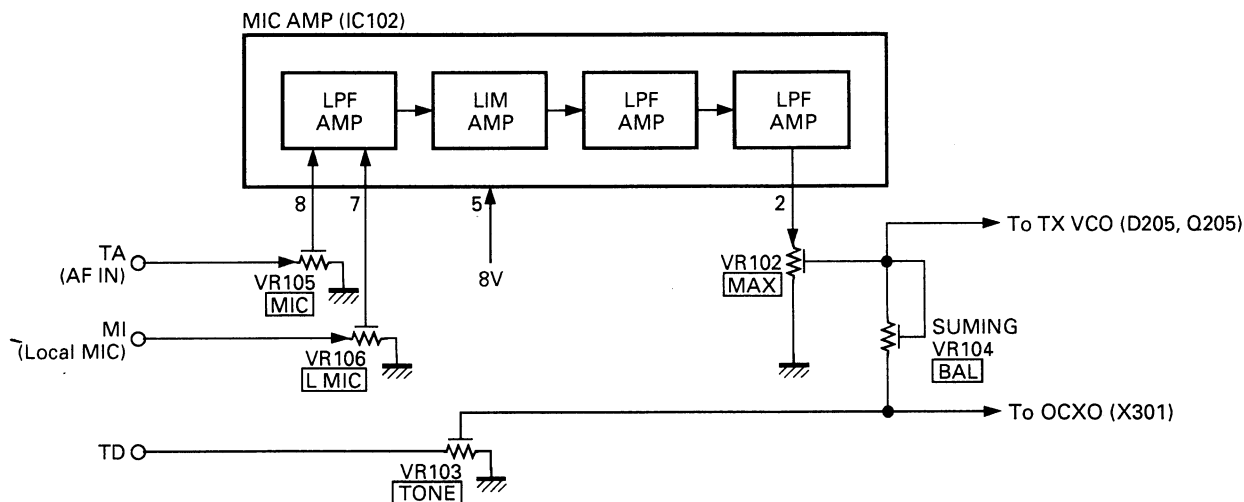

Fig. 5 Microphone amplifier

#### 3-2. Frequency synthesizer (PLL)

The frequency synthesizer section (PLL) consists of a OCXO (X301), a VCO circuit, a phase-locked loop (PLL) circuit, and a UL detection circuit. The OCXO operates at 12.8 MHz, its frequency being maintained within  $\pm 0.1$ ppm from  $-30$  to  $+60^\circ\text{C}$ . One signal output from the OCXO is routed to the PLL IC (IC201), and is divided by 1024 by IC201 to generate the 12.5-kHz reference signal. The other signal is amplified by Q209 and output from CN201.

The VCO is produced by Q205. The signal output from the VCO passes through a buffer amplifier (Q203) and is doubled by Q202. The RF signal is sent to two buffer amplifiers (Q201 and Q206). The output from Q201 is directed to the drive module of the transmitter circuit as the PLL output signal. The output from Q206 goes to the PLL IC (IC201).

The VCO signal and OCXO signal are divided according to the divide ratio data sent from the control section to generate the 12.5-kHz signal. The phase of the signal is compared with the reference signal. The phase difference signal is output from the phase comparator, passes through the charge pump and lug-reed low-pass filter, and is applied to D201 and D202 as the VCO control voltage, and is applied to control the VCO frequency.

If the PLL is unlocked, the IC201 lock detect signal is converted to a DC signal by Q207 and IC202. One signal cuts off the power to the transmitter stage by Q102 and Q103 to stop unnecessary transmission. The other signal is sent to the microprocessor in the control section. The microprocessor outputs one UL signal to Q208 to control the LED (D204), and the other to Q106 and Q107 to control the external pin.

The modulation signal from the microphone amplifier goes to D205 to modulate the frequency.

## CIRCUIT DESCRIPTION

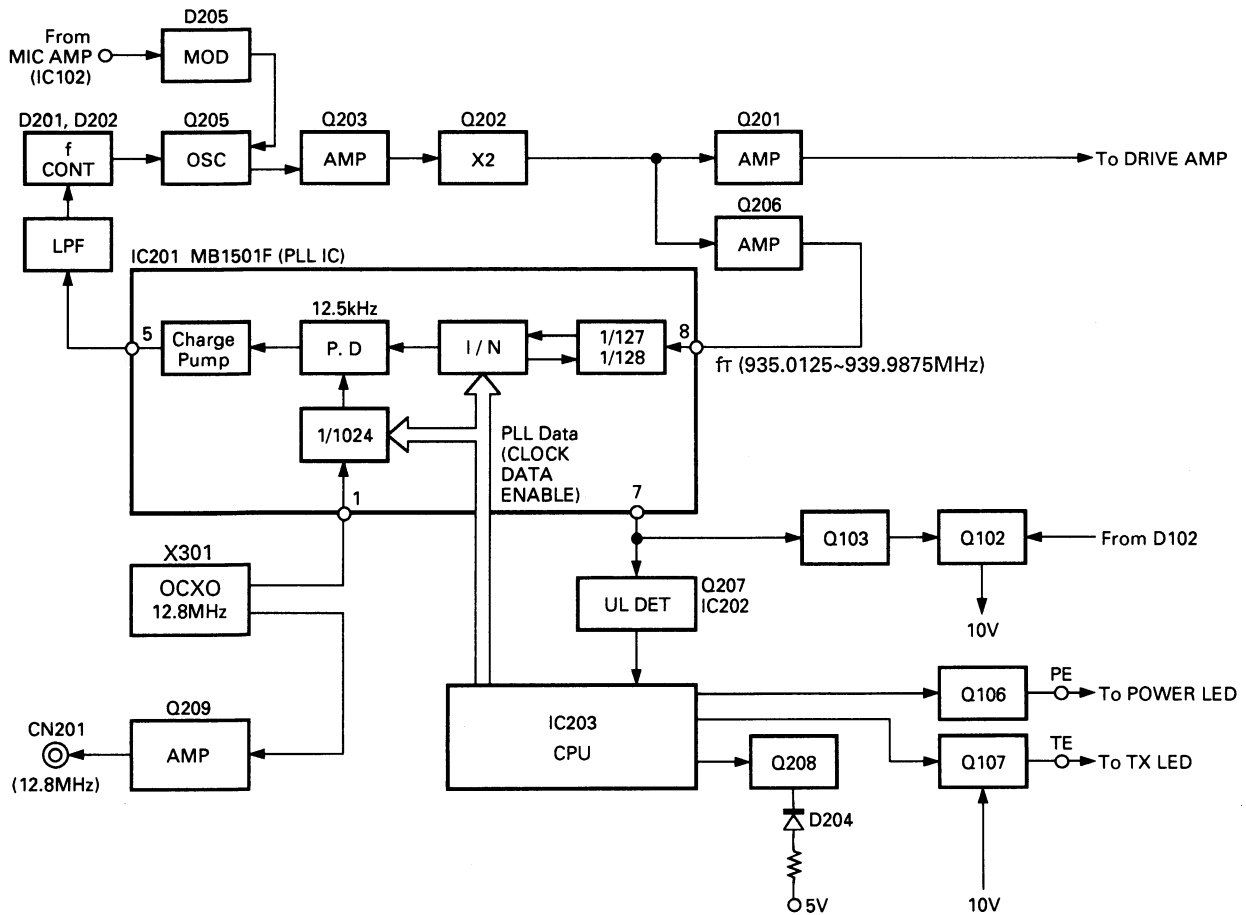

Fig. 6 TX PLL section

### 3-3. Drive amplifier

The RF signal output from the frequency synthesizer section (PLL) passes through band-pass filter L101, goes to high-frequency amplifier module IC101, and a 350-mW signal is output from CN101. The amplified signal is adjusted by the level potentiometer (VR101, D101). The high-frequency filter is a low-pass filter to attenuate the secondary harmonics to 30dB or less

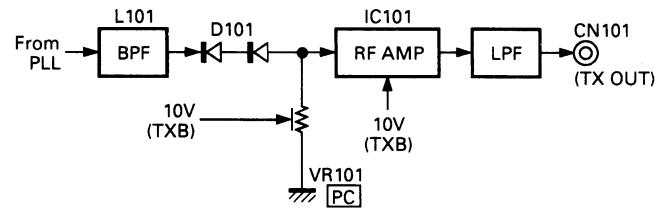

Fig. 7 Drive amplifier

### 3-4. Control section

The microprocessor sends frequency program data to the frequency synthesizer (PLL) according to the transmit channel data from the DIP switch (S201, S202, and S203).

The microprocessor determines whether the frequency synthesizer is locked (high). When it is locked, D204 turns off. When it is unlocked, D204 turns on, and a pulse signal is output to Q106 and Q107 to turn them on or off. (UL indicator)

When switch S204 (non-locking type) is pressed, the microprocessor is reset, and sends frequency program data to the frequency synthesizer.

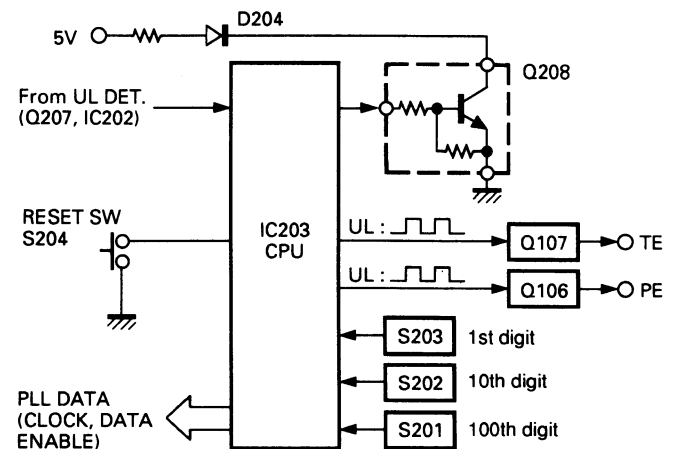
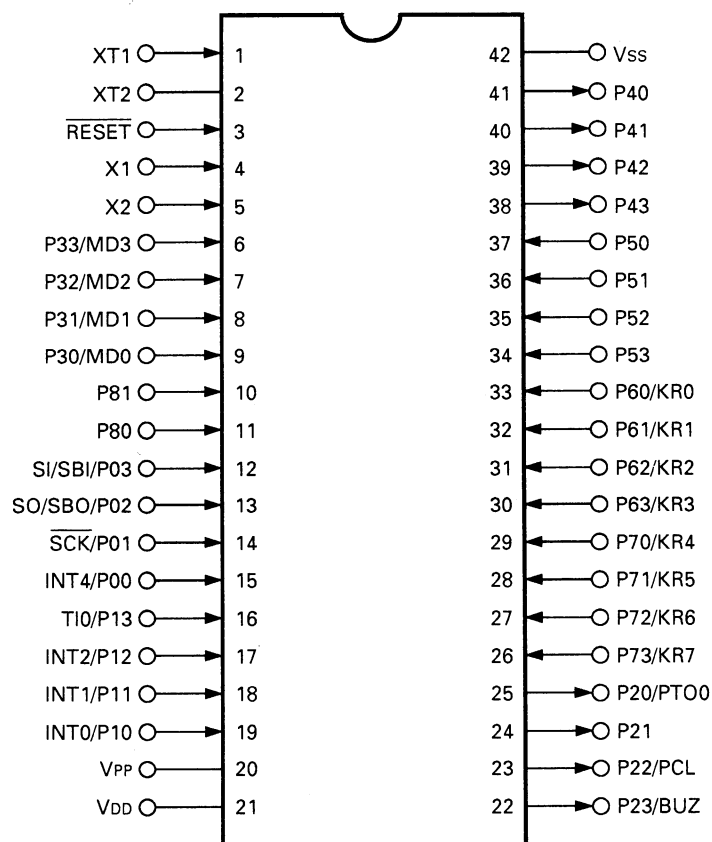

Fig. 8 TX control section

## SEMICONDUCTOR DATA

Microprocessor :  $\mu$ PD75008CU-134 (IC203)

• Terminal connection diagram



• Terminal function

Pin No.	Pin name	I/O	Function
1	XT1	I	Sub clock (not use).
2	XT2	-	
3	RESET	I	System reset input.
4	X1	I	System clock oscillator port.
5	X2	I	
6	P33/MD3	I	1st-digit channel setting.
7	P32/MD2	I	
8	P31/MD1	I	
9	P30/MD0	I	
10	P81	I	Not use.
11	P80	I	
12	SI/SBI/P03	I	
13	SO/SBO/P02	I	
14	SCK/P01	I	
15	INT4/P00	I	Wake up input.
16	TIO/P13	I	Open (not use).
17	INT2/P12	I	
18	INT1/P11	I	Unlock signal input.
19	INT0/P10	I	Open (not use).
20	VPP	-	+5V.
21	VDD	-	

Pin No.	Pin name	I/O	Function
22	P23/BUZ	O	RX enable output.
23	P22/PCL	O	TX enable output.
24	P21	O	Data output.
25	P20/PTO0	O	Clock output.
26	P73/KR7	I	100th-digit channel setting.
27	P72/KR6	I	
28	P71/KR5	I	
29	P70/KR4	I	
30	P63/KR3	I	10th-digit channel setting.
31	P62/KR2	I	
32	P61/KR1	I	
33	P60/KR0	I	
34	P53	I	Pull down.
35	P52	I	RX : "L", TX : "H"
36	P51	I	-12.5kHz when cut the R273.
37	P50	I	Pull up.
38	P43	O	Power LED control.
39	P42	O	TX LED control.
40	P41	O	BUSY LED control.
41	P40	O	PILOT LED control.
42	Vss	-	GND.

## SEMICONDUCTOR DATA

### IF System : MC3371D (RX Unit IC1)

#### • Terminal connection diagram

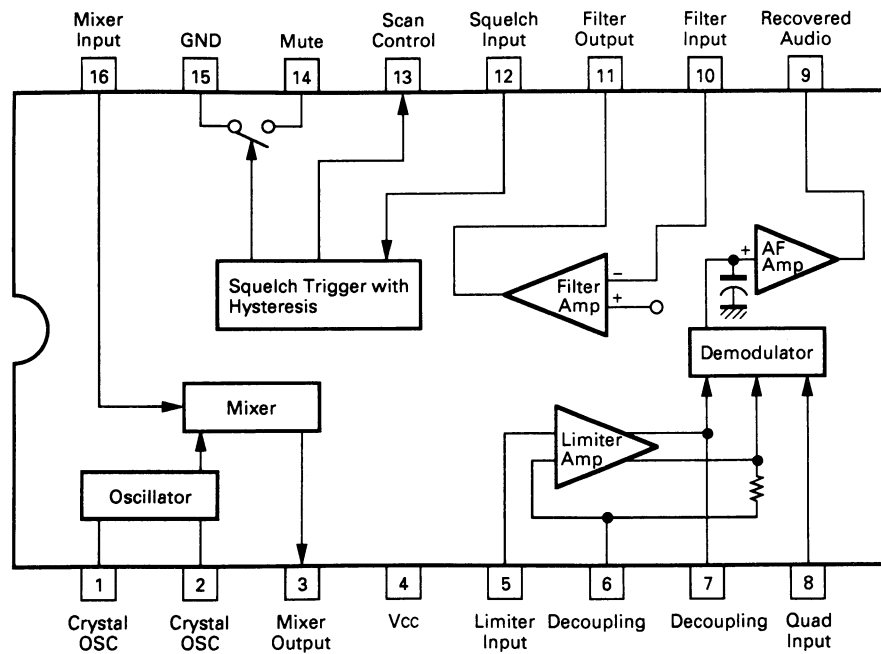

### PLL System : MB1501F (IC201)

#### • Terminal connection diagram

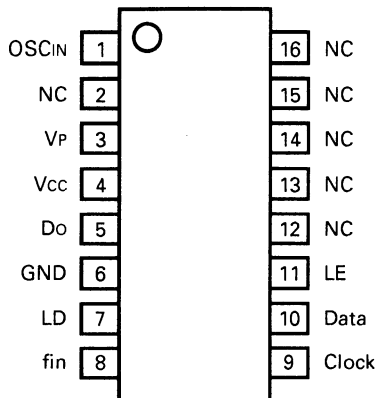

### TX Power Amplifier : M57781 (TX Unit IC101)

#### • Terminal connection diagram

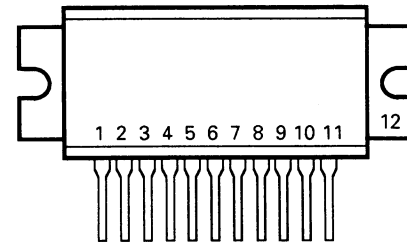

- 1 : Input
- 2-4 : GND
- 5 : First DC supply voltage
- 6-8 : GND
- 9 : Final DC supply voltage
- 10 : GND
- 11 : Output
- 12 : Fin (GND)

#### • Terminal function

Pin No.	Pin name	I/O	Function
1	OSCIN	I	VCXO input.
3	VP	-	Power supply pin for charge pump input.
4	Vcc	-	Power supply pin.
5	Do	O	Charge pump output pin.
6	GND	-	GND.
7	LD	O	Phase detector output. "H" when lock.
8	fin	I	VCO input.
9	Clock	I	PLL data input (Clock).
10	Data	I	PLL data input (Data).
11	LE	I	PLL data input (LE).

# TKR-901

## DESCRIPTION OF COMPONENTS

### RX UNIT (X55-3020-11)

Ref. No.	Parts No.	Use/Function	Operation/Condition
IC1	MC3371D	IF system	See SEMICONDUCTOR DATA.
IC2	NJM4558M	Noise amplifier	
IC3	μPC1241H	AF amplifier	
IC4	KCE02	AF band pass filter	
IC5	TC4S66F	AF MUTE	OFF when busy ON.
IC6	NJM4558M	AF amplifier	
IC201	MB1501F	PLL system	See SEMICONDUCTOR DATA.
IC202	TC4S584F	Lock detector switch	"H" when lock.
IC203	μPD75008CU-134	Microprocessor	See SEMICONDUCTOR DATA.
IC204	M51943BML	Reset IC	
IC205	NJM78L08UA	Voltage regulator	8V
IC206	NJM78L05UA	Voltage regulator	5V
IC207	NJM78L08UA	Voltage regulator	8V
Q1	2SC4093	RF amplifier	
Q2	3SK184(S)	RX 1st mixer	
Q3	2SC2714(Y)	RX 1st IF amplifier	39.0375MHz
Q4	2SC2712(Y)	Audio mute switch	
Q5	DTC114YK	Inverter	BUSY
Q6	FMG5	DC switch	ON when Busy and unlock.
Q201	2SC3356	RF amplifier	
Q202	2SC3356	Doubler	
Q203	2SC3356	Buffer amplifier	
Q204	2SC2712(Y)	Ripple filter	7.2V
Q205	2SK508NV(K52)	Oscillator	(856.975~861.950MHz)
Q206	2SC3356	Buffer amplifier	
Q207	2SA1162(Y)	Lock detector switch	"H" when lock.
Q208	DTC114EK	DC switch	"H" when lock.
D1	HSM88AS	Noise detector	
D2	ERZ-M10DK220	Surge absorber	
D3	DSA3A1	Reverse polarity protection	
D201,202	1T33C	Tuning	
D204	B30-0838-05	LED	Light when unlock.

## DESCRIPTION OF COMPONENTS

## TX UNIT (X56-3020-11)

Ref. No.	Parts No.	Use/Function	Operation/Condition
IC101	M57781	TX Power amplifier	See SEMICONDUCTOR DATA.
IC102	KCA03	MIC amplifier	2 : AF OUT 7, 8 : AF IN
IC201	MB1501F	PLL system	See SEMICONDUCTOR DATA.
IC202	TS4S584F	Lock detector switch	"H" when dock.
IC203	μPD75008CU-134	Microprocessor	See SEMICONDUCTOR DATA.
IC204	M51943BML	Reset IC	
IC205	NJM78L08UA	Voltage regulator	8V
IC206	NJM78L05UA	Voltage regulator	5V
IC207	NJM78L08UA	Voltage regulator	8V
IC301	TA75S01F	Tone encode signal amplifier	
Q101	2SD1682(R,S)	DC switch	
Q102	2SB1119(S)	DC switch	ON when lock and PTT ON.
Q103	DTC114EK	DC switch	ON when lock.
Q104	DTA114EK	DC switch	ON when PTT ON.
Q105	DTC114EK	AF MUTE	ON when MIC PTT.
Q106	DTC114YK	DC switch	ON when lock.
Q107	FMG5	DC switch	ON when lock and PTT ON.
Q201	2SC3356	RF amplifier	
Q202	2SC3356	Doubler	
Q203	2SC3356	Buffer amplifier	
Q204	2SC2712(Y)	Ripple filter	7.2V
Q205	2SK508NV(K52)	Oscillator	(935.0125~939.9875MHz)
Q206	2SC3356	Buffer amplifier	
Q207	2SA1162(Y)	Lock detector switch	"H" when lock.
Q208	DTC114EK	DC switch	"H" when lock.
Q209	2SC2714(Y)	Buffer amplifier	(12.8MHz)
D101	1SV172	RF switch	ON when TX.
D102	02CZ10(X,Y)	Voltage reference	9.5V
D103	1SS184	Current steering	
D201,202	1T33C	Tuning	
D204	B30-0838-05	LED	Light when unlock.
D205	1SV164	Modulator	



# TKR-901

## PARTS LIST

### CAPACITORS

CC 45 TH 1H 220 ↓  
 1 2 3 4 5 6

- 1 = Type ... ceramic, electrolytic, etc.    4 = Voltage rating  
 2 = Shape ... round, square, ect.        5 = Value  
 3 = Temp. coefficient                        6 = Tolerance

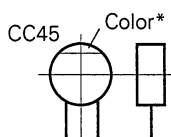

#### • Capacitor value

- 010 = 1pF  
 100 = 10pF  
 101 = 100pF  
 102 = 1000pF = 0.001μF  
 103 = 0.01μF

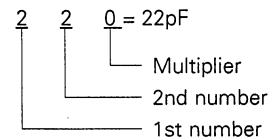

#### • Temperature coefficient

1st Word	C	L	P	R	S	T	U
Color*	Black	Red	Orange	Yellow	Green	Blue	Violet
ppm/°C	0	-80	-150	-220	-330	-470	-750

2nd Word	G	H	J	K	L
ppm/°C	±30	±60	±120	±250	±500

Example : CC45TH = -470 ± 60ppm/°C

#### • Tolerance

Code	C	D	G	J	K	M	X	Z	P	No code
(%)	±0.25	±0.5	±2	±5	±10	±20	+40 -20	+80 -20	+100 -0	More than 10μF -10 ~ +50 Less than 4.7μF -10 ~ +75

#### Less than 10pF

Code	B	C	D	F	G
(pF)	±0.1	±0.25	±0.5	±1	±2

#### • Voltage rating

2nd word \ 1st word	A	B	C	D	E	F	G	H	J	K	V
0	1.0	1.25	1.6	2.0	2.5	3.15	4.0	5.0	6.3	8.0	-
1	10	12.5	16	20	25	31.5	40	50	63	80	35
2	100	125	160	200	250	315	400	500	630	800	-
3	1000	1250	1600	2000	2500	3150	4000	5000	6300	8000	-

#### • Chip capacitors (Refer to the table above except dimension)

(EX) CC 73 F SL 1H 000 ↓  
 1 2 3 4 5 6 7  
 (Chip) (CH, RH, UJ, SL)

(EX) CK 73 F F 1H 000 ↓  
 1 2 3 4 5 6 7  
 (Chip) (B, F)

#### Dimension

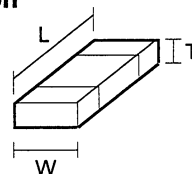

#### • Dimension (Chip capacitor)

Dimension code	L	W	T
Empty	5.6 ± 0.5	5.0 ± 0.5	Less than 2.0
E	3.2 ± 0.2	1.6 ± 0.2	Less than 1.25
F	2.0 ± 0.3	1.25 ± 0.2	Less than 1.25

#### • Dimension (Chip resistor)

Dimension code	L	W	T	Wattage
E	3.2 ± 0.2	1.6 ± 0.2	0.57	2B
F	2.0 ± 0.3	1.25 ± 0.2	0.45	2A

### RESISTORS

#### • Chip resistor (Carbon)

(EX) RD 73 E B 2B 000 ↓  
 1 2 3 4 5 6 7  
 (Chip) (B,F)

#### • Carbon resistor (Normal type)

(EX) RD 14 B B 2C 000 ↓  
 1 2 3 4 5 6 7

- 1 = Type ... ceramic, electrolytic, etc.    5 = Voltage rating  
 2 = Shape ... round, square, ect.        6 = Value  
 3 = Dimension                                7 = Tolerance  
 4 = Temp. coefficient

#### Rating wattage

Code	Wattage	Code	Wattage	Code	Wattage
2A	1/10W	2E	1/4W	3A	1W
2B	1/8W	2H	1/2W	3D	2W
2C	1/6W				

## PARTS LIST

× New Parts

Parts without Parts No. are not supplied.

Les articles non mentionnés dans le Parts No. ne sont pas fournis.

Teile ohne Parts No. werden nicht geliefert.

TKR-901

Ref. No. 参照番号	Address 位置	New Parts 新	Parts No. 部品番号	Description 部品名/規格	Desti- nation 仕向	Re- marks 備考
<b>TKR-901</b>						
1	1A		A01-2076-02	METALLIC CABINET(UPPER)		
2	3B		A10-1333-02	CHASSIS		
3	1A, 2B		A13-1604-05	FRAME(UPPER)		
4	2A, 3B		A13-1605-05	FRAME(BOTTOM)		
5	3B		A40-0639-02	BOTTOM PLATE		
6	1A, 3B		A50-0411-13	SIDE PLATE		
7	3A		A62-0248-05	PANEL(FRONT)		
8	1B		A82-0014-05	PANEL(REAR)		
10	3A		B30-0855-05	LED(TX)		
11	3A		B30-0856-05	LED(BUSY/POWER)		
12	2A, 1B		B42-2437-04	S/NO LABEL(UNIT)		
13	1B		B42-3343-04	S/NO LABEL(RADIO)		
14	1B	*	B72-0606-04	MODEL NAME PLATE		
15	3C		B42-5526-04	LABEL		
16	1B		E37-0334-05	CONNECTING WIRE(TX OUT)		
17	1B		E37-0335-05	CONNECTING WIRE(RX ANT)		
18	3A		E37-0336-05	CONNECTING WIRE(6P)		
-			E37-0337-05	CONNECTING WIRE(2P/LED)		
-			E37-0338-05	CONNECTING WIRE(3P/VOL)		
21	1B		E37-0339-15	CONNECTING WIRE(2P/DC)		
-			E37-0340-05	CONNECTING WIRE(2P/SP)		
-			E37-0342-05	CONNECTING WIRE(2P/TEST)		
24	1B		E37-0343-05	CONNECTING WIRE(15P/D-SUB)		
-			E37-0346-05	CONNECTING WIRE(1P-1P)		
-			E37-0378-05	CONNECTING WIRE(4P/LED)		
28	1B, 1D		F06-3023-05	FUSE(3A)		
29	1A, 1B		F11-1057-03	SHIELDING COVER(FRAME)		
30	3A		G53-0760-04	PACKING		
40	2A, 2B		G13-1305-04	CUSHION		
31	3A		G09-0405-05	SPRING(VOL KNOB)		
32	3A		G10-0651-04	SHEET(SP)		
33	2A, 3B		G10-0742-04	SHEET		
34	2C, 1D		H10-2770-02	POLYSTYRENE FOAMED FIXTURE		
35	2D		H12-1453-02	PACKING FIXTURE		
36	2D		H25-0361-04	PROTECTION BAG		
37	1D		H25-0029-04	PROTECTION BAG		
38	1C		H25-0761-04	PROTECTION BAG		
39	3D	*	H52-0498-04	ITEM CARTON BOX		
41	2A, 2B		J11-0149-05	CLAMPER		
42	1B		J13-0033-15	FUSE HOLDER		
43	3A		J19-1423-05	HOLDER(LED)		
44	3A		J21-2717-14	MOUNTING HARDWARE(SP)		
45	2A, 2B		J21-4244-04	MOUNTING HARDWARE(FRAME)		
46	1B		J21-4341-04	MOUNTING HARDWARE(DC/2P)		
47	3B		J21-4431-04	MOUNTING HARDWARE		
48	2A, 2B		J21-4432-05	MOUNTING HARDWARE(FRAME)		
49	1B		J32-0921-05	STUD & BOSS(D-SUB)		
51	1D		K01-0418-05	HANDLE & KNOB(ACS)		
52	3A		K29-4797-04	KNOB (VOL)		

L:Scandinavia

K:USA

P:Canada

Y:PX(Far East, Hawaii)

T:England

E:Europe

Y:AAFES(Europe)

X:Australia

M:Other Areas

▲ indicates safety critical components.

# TKR-901

## PARTS LIST

× New Parts

Parts without Parts No. are not supplied.

Les articles non mentionnes dans le Parts No. ne sont pas fournis.

Teile ohne Parts No. werden nicht geliefert.

TKR-901

RX UNIT (X55-3020-11)

Ref. No. 参照番号	Address 位置	New Parts 新	Parts No. 部品番号	Description 部品名 / 規格	Desti- nation 仕 向	Re- marks 備考
A	2A, 2B		N09-2084-05	SCREW		
B	1D		N16-0030-41	SPRING WASHER(D-SUB)		
C	3A, 2B		N32-3006-46	FLAT HEAD MACHIN SCREW		
D	3A		N33-2606-45	OVAL HEAD MACHIN SCREW		
E	1A, 3B		N35-3006-45	BINDING HEAD MACHINE SCREW		
F	1B		N35-3006-46	BINDING HEAD MACHINE SCREW		
G	2A, 2B		N35-4006-46	BINDING HEAD MACHINE SCREW		
H	1A, 1B		N87-2608-46	BRAZIER HEAD TAPTITE SCREW		
J	1B		N89-4008-45	BINDING HEAD TAPTITE SCREW		
54	3A		R05-3467-05	POTENTIOMETER (10K/A)		
-			R92-0150-05	JUMPER REST 0 OHM		
57	3A		S68-0408-05	PUSH SWITCH (TEST)		
59	3A		T07-0246-05	LOUDSPEAKER(FULLRANGE)		
61	2A	*	X55-3020-11	RX UNIT		
62	2B	*	X56-3020-11	TX UNIT		
-			212-3702-05	PLASTIC TUBE		
<b>RX UNIT (X55-3020-11)</b>						
101	2A		A13-0684-11	FRAME		
C1			CC73FCH1H060D	CHIP C 6PF D		
C2			CC73FCH1H010C	CHIP C 1PF C		
C3			CC73FCH1H020C	CHIP C 2PF C		
C4			CC73FCH1H030C	CHIP C 3PF C		
C5			CC73FCH1H010C	CHIP C 1PF C		
C7			CK73FB1H102K	CHIP C 1000PF K		
C8 ,9			CK73FB1H471K	CHIP C 470PF K		
C10 ,11			CC73FSL1H101J	CHIP C 100PF J		
C12 ,13			CK73FB1H102K	CHIP C 1000PF K		
C14			CC73FCH1H080D	CHIP C 8PF D		
C15 ,16			CK73FB1H102K	CHIP C 1000PF K		
C17			CK73FB1E104K	CHIP C 0.10UF K		
C18			C92-0009-05	CHIP TAN 4.7UF 10WV		
C19 ,20			CK73FB1E104K	CHIP C 0.10UF K		
C21			CC73FCH1H330J	CHIP C 33PF J		
C22			CK73FB1H102K	CHIP C 1000PF K		
C23			CC73FCH1H100D	CHIP C 10PF D		
C24			CK73FB1H102K	CHIP C 1000PF K		
C25 ,26			CC73FCH1H680J	CHIP C 68PF J		
C27 ,28			CC73FCH1H470J	CHIP C 47PF J		
C29			CK73FB1E223K	CHIP C 0.022UF K		
C30			CE04EW1C470M	ELECTRO 47UF 16WV		
C32			CE04EW1C470M	ELECTRO 47UF 16WV		
C33			CK73FB1H102K	CHIP C 1000PF K		
C34			CK73FB1E103K	CHIP C 0.01UF K		
C35 -37			CE04EW1C470M	ELECTRO 47UF 16WV		
C38			CK73FB1E103K	CHIP C 0.01UF K		
C39			CE04EW1A221M	ELECTRO 220UF 10WV		
C40			CE04EW1C470M	ELECTRO 47UF 16WV		
C41			CE04EW1E470M	ELECTRO 47UF 25WV		
C42			CK73FB1E103K	CHIP C 0.01UF K		
C43			C092M1H104K	MYLAR 0.10UF K		
C44			CE04EW1E471M	ELECTRO 470UF 25WV		

L:Scandinavia

K:USA

P:Canada

Y:PX(Far East, Hawaii)

T:England

E:Europe

Y:AAFES(Europe)

X:Australia

M:Other Areas

△ indicates safety critical components.

## PARTS LIST

× New Parts

Parts without Parts No. are not supplied.

Les articles non mentionnes dans le Parts No. ne sont pas fournis.

Teile ohne Parts No. werden nicht geliefert.

RX UNIT (X55-3020-11)

Ref. No. 参照番号	Address 位置	New Parts 新	Parts No. 部品番号	Description 部品名 / 規格	Desti- nation 仕 向	Re- marks 備考
C45			CK73FB1H102K	CHIP C 1000PF K		
C46, 47			CK73FB1H471K	CHIP C 470PF K		
C48			CE04EW1C470M	ELECTRØ 47UF 16WV		
C49			CK73FB1E104K	CHIP C 0.10UF K		
C50			CE04EW1C470M	ELECTRØ 47UF 16WV		
C51			CK73FB1H103K	CHIP C 0.010UF K		
C52 -58			CC73FSL1H101J	CHIP C 100PF J		
C201			CC73FCH1H020C	CHIP C 2PF C		
C204			CK73FB1H103K	CHIP C 0.010UF K		
C205			CC73FCH1H010C	CHIP C 1PF C		
C206, 207			CK73FB1H471K	CHIP C 470PF K		
C208			CC73FCH1H030C	CHIP C 3PF C		
C209			CC73FCH1H020C	CHIP C 2.0PF C		
C210			CC73FCH1H470J	CHIP C 47PF J		
C211			CC73FCH1H030C	CHIP C 3PF C		
C212			CC73FCH1H040C	CHIP C 4PF C		
C213, 214			CK73FB1H102K	CHIP C 1000PF K		
C215			CC73FCH1H010C	CHIP C 1PF C		
C216			CC73FCH1H150J	CHIP C 15PF J		
C217			CK73FB1H471K	CHIP C 470PF K		
C218			CC73FCH1H100D	CHIP C 10PF D		
C219			CC73FCH1H090D	CHIP C 9PF D		
C220			CC73FCH1H110J	CHIP C 11PF J		
C221			CC73FCH1H030C	CHIP C 3PF C		
C222			CK73FB1H471K	CHIP C 470PF K		
C223			CK73FB1H102K	CHIP C 1000PF K		
C224, 225			C92-0514-05	CHIP TAN 2.2UF 10WV		
C226			CE04EW1C470M	ELECTRØ 47UF 16WV		
C228			CC73FCH1H010C	CHIP C 1PF C		
C229			CK73FB1H102K	CHIP C 1000PF K		
C230			CC73FCH1H100D	CHIP C 10PF D		
C231			CC73FCH1H020C	CHIP C 2PF C		
C232, 233			C92-0543-05	CHIP TAN 3.3UF 10WV		
C234			CK73FB1H102K	CHIP C 1000PF K		
C235			C92-0004-05	ELECTRØ 1.0UF 16WV		
C236			CK73FB1H102K	CHIP C 1000PF K		
C237			C92-0004-05	ELECTRØ 1.0UF 16WV		
C238			CC73FSL1H101J	CHIP C 100PF J		
C239, 240			CC73FCH1H100D	CHIP C 10PF D		
C241-245			CC73FSL1H101J	CHIP C 100PF J		
C246			CK73FB1H102K	CHIP C 1000PF K		
C255			CK73FB1H102K	CHIP C 1000PF K		
C260, 261			CK73FB1H102K	CHIP C 1000PF K		
C262			CE04EW1C101M	ELECTRØ 100UF 16WV		
C263, 264			CK73FB1H102K	CHIP C 1000PF K		
C265			CE04EW1C101M	ELECTRØ 100UF 16WV		
C266			CK73FB1H102K	CHIP C 1000PF K		
C267			CE04EW1C101M	ELECTRØ 100UF 16WV		
C268			CK73FB1H102K	CHIP C 1000PF K		
C269			CE04EW1A221M	ELECTRØ 220UF 10WV		
C272			CK73FB1E333K	CHIP C 0.033UF K		
C273			CK73FB1H102K	CHIP C 1000PF K		
C274			CC73FCH1H100D	CHIP C 10PF D		
C275			CC73FCH1H470J	CHIP C 47PF J		

L:Scandinavia

K:USA

P:Canada

Y:PX(Far East, Hawaii)

T:England

E:Europe

Y:AAFES(Europe)

X:Australia

M:Other Areas

⚠ indicates safety critical components.

## PARTS LIST

× New Parts

Parts without Parts No. are not supplied.

Les articles non mentionnes dans le Parts No. ne sont pas fournis.

Teile ohne Parts No. werden nicht geliefert.

RX UNIT (X55-3020-11)

Ref. No. 参照番号	Address 位置	New Parts 新	Parts No. 部品番号	Description 部品名 / 規格	Desti- nation 仕 向	Re- marks 備考
CN2			E40-3237-05	PIN ASSY(2P)		
CN3			E40-3239-05	PIN ASSY(4P)		
CN4			E40-3243-05	PIN ASSY(8P)		
CN6			E40-3238-05	PIN ASSY(3P)		
CN7			E40-3237-05	PIN ASSY(2P)		
CN8			E04-0174-05	RF COAXIAL CABLE RECEPTACLE		
CN201			E04-0174-05	RF COAXIAL CABLE RECEPTACLE		
CN202			E23-0467-05	TERMINAL (TEST)		
102	2A		F10-2081-04	SHIELDING PLATE(PLL)		
-			F10-2082-04	SHIELDING PLATE(VCO)		
104	1A		G02-0570-04	LEAF SPRING (AF)		
105	2A		G02-0741-04	LEAF SPRING (FRONT)		
-			J30-0545-05	SPACER (X1)		
106	2A		K23-0901-05	KNØB (CH SW)		
CF1			L72-0360-05	CERAMIC FILTER(455KHZ)		
L1		*	L34-1306-15	CØIL		
L2			L79-1098-05	FILTER(2R-899MHZ)		
L3			L40-1072-48	SMALL FIXED INDUCTØR(10NH)		
L4			L79-1099-05	FILTER(3R-899MHZ)		
L6			L34-4237-05	CØIL		
L7			L30-0503-05	IFT		
L8			L40-6882-48	SMALL FIXED INDUCTØR(680NH)		
L201			L40-1072-48	SMALL FIXED INDUCTØR(10NH)		
L202			L40-1572-48	SMALL FIXED INDUCTØR(15NH)		
L203			L40-3372-48	SMALL FIXED INDUCTØR(33NH)		
L204			L40-1092-48	SMALL FIXED INDUCTØR(1UH)		
L205			L40-2292-48	SMALL FIXED INDUCTØR(2.2UH)		
L206, 207			L40-1092-48	SMALL FIXED INDUCTØR(1UH)		
L208			L40-1072-48	SMALL FIXED INDUCTØR(10NH)		
L209			L34-4240-05	CØIL		
L210			L92-0130-05	CØRE		
X1			L77-1434-05	CRYSTAL RESONATOR(38.5825MHZ)		
X202			L78-0017-05	RESONATOR (4.194MHZ)		
XF1			L71-0430-05	CRYSTAL FILTER(39.0375MHZ)		
K	2A		N87-2608-46	BRAZIER HEAD TAPTITE SCREW		
R1			R92-0670-05	CHIP R 0 ØHM		
R2			RK73FB2A470J	CHIP R 47 J 1/10W		
R3			RK73FB2A473J	CHIP R 47K J 1/10W		
R4			RK73FB2A561J	CHIP R 560 J 1/10W		
R5			RK73FB2A471J	CHIP R 470 J 1/10W		
R6			RK73FB2A103J	CHIP R 10K J 1/10W		
R7			RK73FB2A101J	CHIP R 100 J 1/10W		
R8			RK73FB2A681J	CHIP R 680 J 1/10W		
R9			RK73FB2A684J	CHIP R 680K J 1/10W		
R10 , 11			RK73FB2A223J	CHIP R 22K J 1/10W		
R12			RK73FB2A331J	CHIP R 330 J 1/10W		
R13			RK73FB2A332J	CHIP R 3.3K J 1/10W		
R14			RK73FB2A334J	CHIP R 330K J 1/10W		
R15			RK73FB2A474J	CHIP R 470K J 1/10W		
R16			RK73FB2A103J	CHIP R 10K J 1/10W		
R17			RK73FB2A272J	CHIP R 2.7K J 1/10W		

L:Scandinavia

K:USA

P:Canada

Y:PX(Far East, Hawaii)

T:England

E:Europe

Y:AAFES(Europe)

X:Australia

M:Other Areas

△ indicates safety critical components.

## PARTS LIST

× New Parts

Parts without Parts No. are not supplied.

Les articles non mentionnes dans le Parts No. ne sont pas fournis.

Teile ohne Parts No. werden nicht geliefert.

RX UNIT (X55-3020-11)

Ref. No. 参照番号	Address 位置	New Parts 新	Parts No. 部品番号	Description 部品名 / 規格	Desti- nation 仕 向	Re- marks 備考
R18			RK73FB2A472J	CHIP R 4.7K J 1/10W		
R21			RK73FB2A101J	CHIP R 100 J 1/10W		
R22			RK73FB2A332J	CHIP R 3.3K J 1/10W		
R23			RK73FB2A103J	CHIP R 10K J 1/10W		
R24			RK73FB2A393J	CHIP R 39K J 1/10W		
R25			RK73FB2A331J	CHIP R 330 J 1/10W		
R26			RK73FB2A2R2J	CHIP R 2.2 J 1/10W		
R27			RK73FB2A103J	CHIP R 10K J 1/10W		
R28 ,29			R92-0699-05	SOLID 10 1/2W		
R31			RK73FB2A102J	CHIP R 1.0K J 1/10W		
R32			RK73FB2A473J	CHIP R 47K J 1/10W		
R34			RK73FB2A273J	CHIP R 27K J 1/10W		
R35 ,36			RK73FB2A103J	CHIP R 10K J 1/10W		
R37 ,38			RK73FB2A104J	CHIP R 100K J 1/10W		
R39 ,40			RK73FB2A103J	CHIP R 10K J 1/10W		
R41			RK73FB2A102J	CHIP R 1.0K J 1/10W		
R42			RK73FB2A222J	CHIP R 2.2K J 1/10W		
R43 ,44			RK73FB2A104J	CHIP R 100K J 1/10W		
R45 ,46			RK73FB2A103J	CHIP R 10K J 1/10W		
R47			R92-0670-05	CHIP R 0 0HM		
R49 ,50			R92-0670-05	CHIP R 0 0HM		
R201			RK73FB2A180J	CHIP R 18 J 1/10W		
R202 ,203			RK73FB2A271J	CHIP R 270 J 1/10W		
R204			RK73FB2A181J	CHIP R 180 J 1/10W		
R205			RK73FB2A682J	CHIP R 6.8K J 1/10W		
R206			RK73FB2A183J	CHIP R 18K J 1/10W		
R207			RK73FB2A101J	CHIP R 100 J 1/10W		
R208			RK73FB2A473J	CHIP R 47K J 1/10W		
R209 ,210			RK73FB2A101J	CHIP R 100 J 1/10W		
R211			RK73FB2A103J	CHIP R 10K J 1/10W		
R212			RK73FB2A223J	CHIP R 22K J 1/10W		
R213			RK73FB2A101J	CHIP R 100 J 1/10W		
R214			RK73FB2A472J	CHIP R 4.7K J 1/10W		
R215			RK73FB2A101J	CHIP R 100 J 1/10W		
R216			RK73FB2A181J	CHIP R 180 J 1/10W		
R217			RK73FB2A221J	CHIP R 220 J 1/10W		
R218-220			RK73FB2A102J	CHIP R 1.0K J 1/10W		
R221			RK73FB2A561J	CHIP R 560 J 1/10W		
R222			RK73FB2A473J	CHIP R 47K J 1/10W		
R223			RK73FB2A104J	CHIP R 100K J 1/10W		
R224			RK73FB2A103J	CHIP R 10K J 1/10W		
R225			RK73FB2A223J	CHIP R 22K J 1/10W		
R226			RK73FB2A470J	CHIP R 47 J 1/10W		
R227			RK73FB2A101J	CHIP R 100 J 1/10W		
R228 ,229			RK73FB2A100J	CHIP R 10 J 1/10W		
R230			R92-0670-05	CHIP R 0 0HM		
R231			RK73FB2A333J	CHIP R 33K J 1/10W		
R232			RK73FB2A472J	CHIP R 4.7K J 1/10W		
R233			RK73FB2A123J	CHIP R 12K J 1/10W		
R234			RK73FB2A473J	CHIP R 47K J 1/10W		
R239			RK73FB2A102J	CHIP R 1.0K J 1/10W		
R240			RK73FB2A473J	CHIP R 47K J 1/10W		
R241			RK73FB2A102J	CHIP R 1.0K J 1/10W		
R244			R92-0670-05	CHIP R 0 0HM		
R245			RK73FB2A102J	CHIP R 1.0K J 1/10W		

L:Scandinavia

K:USA

P:Canada

Y:PX(Far East, Hawaii)

T:England

E:Europe

Y:AAFES(Europe)

X:Australia

M:Other Areas

△ indicates safety critical components.

## PARTS LIST

× New Parts

Parts without **Parts No.** are not supplied.

Les articles non mentionnes dans le **Parts No.** ne sont pas fournis.

Teile ohne **Parts No.** werden nicht geliefert.

**RX UNIT (X55-3020-11)**

**TX UNIT (X56-3020-11)**

Ref. No. 参照番号	Address 位置	New Parts 新	Parts No. 部品番号	Description 部品名 / 規格	Desti- nation 仕 向	Re- marks 備考
R246			R92-0670-05	CHIP R 0 0HM		
R247, 248			RK73FB2A102J	CHIP R 1.0K J 1/10W		
R249-255			RK73FB2A473J	CHIP R 47K J 1/10W		
R256			RK73FB2A102J	CHIP R 1.0K J 1/10W		
R257			RK73FB2A473J	CHIP R 47K J 1/10W		
R260			RK73FB2A473J	CHIP R 47K J 1/10W		
R272, 273			R92-0150-05	JUMPER REST 0 0HM		
R274			R92-0670-05	CHIP R 0 0HM		
R276			RK73FB2A473J	CHIP R 47K J 1/10W		
R277			R92-0670-05	CHIP R 0 0HM		
R278			R92-0670-05	CHIP R 0 0HM		
R279-281			R92-0670-05	CHIP R 0 0HM		
R301			R92-0670-05	CHIP R 0 0HM		
VR1 ,2			R12-3132-05	TRIM POT. 47K		
S201-203			S79-0408-05	SWITCH(CH)		
S204			S40-2446-05	PUSH SWITCH		
D1			HSM88AS	DIODE		
D2			ERZ-M10DK220	SURGE ABSORBER		
D3			DSA3A1	DIODE		
D201, 202			1T33C	DIODE		
D204			B30-0838-05	LED		
IC1			MC3371D	IC(FM IF)		
IC2			NJM4558M	IC(OP AMP X2)		
IC3			UPC1241H	IC		
IC4			KCE02	IC(AF BPF)		
IC5			TC4S66F	IC(BILATERAL SWITCH)		
IC6			NJM4558M	IC(OP AMP X2)		
IC201			MB1501F	IC(PLL FREQ SYNTHESIZER)		
IC202			TC4S584F	IC(SCHMITT TRIGGER)		
IC202			SC14S584F	IC(SCHMITT TRIGGER)		
IC203			UPD75008CU-134	IC (CPU)		
IC204			M51943BML	IC(SYSTEM RESET)		
IC205			NJM78L08UA	IC(VOLTAGE REGULATOR/ +8V)		
IC206			NJM78L05UA	IC(VOLTAGE REGULATOR/ +5V)		
IC207			NJM78L08UA	IC(VOLTAGE REGULATOR/ +8V)		
Q1			2SC4093	TRANSISTOR		
Q2			3SK184(S)	FET		
Q3			2SC2714(Y)	TRANSISTOR		
Q4			2SC2712(Y)	TRANSISTOR		
Q5			DTC114YK	DIGITAL TRANSISTOR		
Q6			FMG5	TRANSISTOR		
Q201-203			2SC3356	TRANSISTOR		
Q204			2SC2712(Y)	TRANSISTOR		
Q205			2SK508NV(K52)	FET		
Q206			2SC3356	TRANSISTOR		
Q207			2SA1162(Y)	TRANSISTOR		
Q208			DTC114EK	DIGITAL TRANSISTOR		
TH1			157-102-55008	THERMISTER(1K)		
<b>TX UNIT (X56-3020-11)</b>						
201	2B		A13-0684-11	FRAME		
C44			CE04EW1E471M	ELECTRO 470UF 25WV		
C101-103			CK73FB1H471K	CHIP C 470PF K		
C106			CK73FB1H102K	CHIP C 1000PF K		

L:Scandinavia

Y:PX(Far East, Hawaii)

Y:AAFES(Europe)

K:USA

T:England

X:Australia

P:Canada

E:Europe

M:Other Areas

 indicates safety critical components.

## PARTS LIST

× New Parts

Parts without Parts No. are not supplied.

Les articles non mentionnés dans le Parts No. ne sont pas fournis.

Teile ohne Parts No. werden nicht geliefert.

TX UNIT (X56-3020-11)

Ref. No. 参照番号	Address 位置	New Parts 新	Parts No. 部品番号	Description 部品名 / 規格	Desti- nation 仕 向	Re- marks 備考
C107			CK73FB1E103K	CHIP C 0.01UF K		
C108			CK73FB1H471K	CHIP C 470PF K		
C109			CK73FB1H102K	CHIP C 1000PF K		
C111			CK73FB1H102K	CHIP C 1000PF K		
C112-118			CK73FB1H471K	CHIP C 470PF K		
C119			CC73FCH1H470J	CHIP C 47PF J		
C120			CK73FB1E183K	CHIP C 0.018UF K		
C121-124			CC73FSL1H101J	CHIP C 100PF J		
C201, 202			CK73FB1H102K	CHIP C 1000PF K		
C203			CC73FCH1H1R5C	CHIP C 1.5PF C		
C204			CC73FCH1H470J	CHIP C 47PF J		
C205			CC73FCH1H040C	CHIP C 4PF C		
C206			CC73FCH1H100D	CHIP C 10PF D		
C207			CK73FB1H471K	CHIP C 470PF K		
C208, 209			CC73FCH1H030C	CHIP C 3PF C		
C210			CK73FB1H471K	CHIP C 470PF K		
C211			CC73FCH1H030C	CHIP C 3PF C		
C212			CC73FCH1H040C	CHIP C 4PF C		
C213, 214			CK73FB1H102K	CHIP C 1000PF K		
C215			CC73FCH1H010C	CHIP C 1PF C		
C216			CC73FCH1H150J	CHIP C 15PF J		
C217			CK73FB1H471K	CHIP C 470PF K		
C218			CC73FCH1H100D	CHIP C 10PF D		
C219			CC73FCH1H040C	CHIP C 4PF C		
C220			CC73FCH1H100D	CHIP C 10PF D		
C221			CC73FCH1H030C	CHIP C 3PF C		
C222			CK73FB1H471K	CHIP C 470PF K		
C223			CK73FB1H102K	CHIP C 1000PF K		
C224, 225			C92-0001-05	CHIP TAN 0.1UF 35WV		
C228			CC73FCH1H010C	CHIP C 1PF C		
C229			CK73FB1H102K	CHIP C 1000PF K		
C230			CC73FCH1H100D	CHIP C 10PF D		
C231			CC73FCH1H020C	CHIP C 2.0PF C		
C232, 233			C92-0543-05	CHIP TAN 3.3UF 10WV		
C234			CK73FB1H102K	CHIP C 1000PF K		
C235			C92-0004-05	ELECTRO 1.0UF 16WV		
C236			CK73FB1H102K	CHIP C 1000PF K		
C237			C92-0004-05	ELECTRO 1.0UF 16WV		
C238			CC73FSL1H101J	CHIP C 100PF J		
C239, 240			CC73FCH1H100D	CHIP C 10PF D		
C241-245			CC73FSL1H101J	CHIP C 100PF J		
C246			CK73FB1H102K	CHIP C 1000PF K		
C249			CK73FB1H102K	CHIP C 1000PF K		
C255			CK73FB1H102K	CHIP C 1000PF K		
C256			C92-0543-05	CHIP TAN 3.3UF 10WV		
C257			CC73FCH1H0R5C	CHIP C 0.5PF C		
C260, 261			CK73FB1H102K	CHIP C 1000PF K		
C262			CE04EW1C101M	ELECTRO 100UF 16WV		
C263, 264			CK73FB1H102K	CHIP C 1000PF K		
C265			CE04EW1C101M	ELECTRO 100UF 16WV		
C266			CK73FB1H102K	CHIP C 1000PF K		
C267			CE04EW1C101M	ELECTRO 100UF 16WV		
C268			CK73FB1H102K	CHIP C 1000PF K		
C269			CE04EW1A221M	ELECTRO 220UF 10WV		
C270			CK73FB1H102K	CHIP C 1000PF K		

L:Scandinavia

K:USA

P:Canada

Y:PX(Far East, Hawaii)

T:England

E:Europe

Y:AAFES(Europe)

X:Australia

M:Other Areas

⚠ indicates safety critical components.



## PARTS LIST

× New Parts

Parts without Parts No. are not supplied.

Les articles non mentionnes dans le Parts No. ne sont pas fournis.

Teile ohne Parts No. werden nicht geliefert.

TX UNIT (X56-3020-11)

Ref. No. 参照番号	Address 位置	New Parts 新	Parts No. 部品番号	Description 部品名 / 規格	Desti- nation 仕向	Re- marks 備考
C271			CE04EW1C100M	ELECTRO 10UF 16WV		
C272			CK73FB1H333K	CHIP C 0.033UF K		
C273			CK73FB1H102K	CHIP C 1000PF K		
C301			CK73FB1H102K	CHIP C 1000PF K		
C302, 303			C92-0009-05	CHIP TAN 4.7UF 10WV		
C304			CK73FB1E103K	CHIP C 0.01UF K		
C305			CK73FB1H102K	CHIP C 1000PF K		
C306			C92-0009-05	CHIP TAN 4.7UF 10WV		
C307			C92-0543-05	CHIP TAN 3.3UF 10WV		
C308			CK73FB1H102K	CHIP C 1000PF K		
CN101			E04-0174-05	RF COAXIAL CABLE RECEPTACLE		
CN102			E40-3237-05	PIN ASSY(2P)		
CN103			E40-3239-05	PIN ASSY(4P)		
CN104			E40-3240-05	PIN ASSY(5P)		
CN105			E40-3237-05	PIN ASSY(2P)		
CN106			E40-3239-05	PIN ASSY(4P)		
CN201			E04-0174-05	RF COAXIAL CABLE RECEPTACLE		
CN202			E23-0467-05	TERMINAL (TEST)		
202	2B		F10-2081-04	SHIELDING PLATE(PLL)		
-			F10-2082-04	SHIELDING PLATE(PLL)		
203	1B		G02-0597-04	LEAF SPRING (MODULE)		
204	1B		G02-0711-04	LEAF SPRING (AVR)		
205	2B		G02-0741-04	LEAF SPRING (FINAL)		
206	2B		K23-0901-05	KNØB (CH SW)		
L101		*	L79-1100-05	FILTER(2R-938MHZ)		
L201			L40-1072-48	SMALL FIXED INDUCTØR(10NH)		
L202			L40-1572-48	SMALL FIXED INDUCTØR(15NH)		
L203			L40-3372-48	SMALL FIXED INDUCTØR(33NH)		
L204			L40-1092-48	SMALL FIXED INDUCTØR(1UH)		
L205			L40-2292-48	SMALL FIXED INDUCTØR(2.2UH)		
L206, 207			L40-1092-48	SMALL FIXED INDUCTØR(1UH)		
L208			L40-1072-48	SMALL FIXED INDUCTØR(10NH)		
L209			L34-4240-05	COIL		
L210			L40-2292-48	SMALL FIXED INDUCTØR(2.2UF)		
L211			L40-1072-48	SMALL FIXED INDUCTØR(10NH)		
L212			L92-0130-05	CØRE		
L213		*	L40-3372-35	SMALL FIXED INDUCTØR(33NH)		
X202			L78-0017-05	RESØNATOR(4.194MHZ)		
X301		*	L77-1536-05	ØCXØ(12.8MZ)		
L	2B		N87-2608-46	BRAZIER HEAD TAPTITE SCREW		
R102			RK73FB2A102J	CHIP R 1.0K J 1/10W		
R103, 104			R92-0699-05	SØLID 10 1/2W		
R105			R92-0679-05	CHIP R 0 ØHM		
R106-108			RK73FB2A102J	CHIP R 1.0K J 1/10W		
R109			R92-0670-05	CHIP R 0 ØHM		
R110			RK73FB2A223J	CHIP R 22K J 1/10W		
R112			RK73FB2A104J	CHIP R 100K J 1/10W		
R113			RK73FB2A473J	CHIP R 47K J 1/10W		
R114			R92-0670-05	CHIP R 0 ØHM		
R115			RK73FB2A561J	CHIP R 560 J 1/10W		
R116			RK73FB2A103J	CHIP R 10K J 1/10W		
R117			RK73FB2A102J	CHIP R 1.0K J 1/10W		

L:Scandinavia

K:USA

P:Canada

Y:PX(Far East, Hawaii)

T:England

E:Europe

Y:AAFES(Europe)

X:Australia

M:Other Areas

△ indicates safety critical components.

## PARTS LIST

× New Parts

Parts without Parts No. are not supplied.

Les articles non mentionnés dans le Parts No. ne sont pas fournis.

Teile ohne Parts No. werden nicht geliefert.

TX UNIT (X56-3020-11)

Ref. No. 参照番号	Address 位置	New Parts 新	Parts No. 部品番号	Description 部品名 / 規格	Desti- nation 仕 向	Re- marks 備考
R118			R92-0670-05	CHIP R 0 ΩHM		
R119			RK73FB2A102J	CHIP R 1.0K J 1/10W		
R120			R92-0670-05	CHIP R 0 ΩHM		
R121			RK73FB2A473J	CHIP R 47K J 1/10W		
R201			R92-0670-05	CHIP R 0 ΩHM		
R204			RK73FB2A101J	CHIP R 100 J 1/10W		
R205			RK73FB2A103J	CHIP R 10K J 1/10W		
R206			RK73FB2A333J	CHIP R 33K J 1/10W		
R207			RK73FB2A101J	CHIP R 100 J 1/10W		
R208			RK73FB2A473J	CHIP R 47K J 1/10W		
R209, 210			RK73FB2A101J	CHIP R 100 J 1/10W		
R211			RK73FB2A103J	CHIP R 10K J 1/10W		
R212			RK73FB2A223J	CHIP R 22K J 1/10W		
R213			RK73FB2A101J	CHIP R 100 J 1/10W		
R214			RK73FB2A472J	CHIP R 4.7K J 1/10W		
R215			RK73FB2A101J	CHIP R 100 J 1/10W		
R216			RK73FB2A181J	CHIP R 180 J 1/10W		
R217			RK73FB2A221J	CHIP R 220 J 1/10W		
R218-220			RK73FB2A102J	CHIP R 1.0K J 1/10W		
R221			RK73FB2A472J	CHIP R 4.7K J 1/10W		
R222			RK73FB2A102J	CHIP R 1.0K J 1/10W		
R223			RK73FB2A104J	CHIP R 100K J 1/10W		
R224			RK73FB2A103J	CHIP R 10K J 1/10W		
R225			RK73FB2A223J	CHIP R 22K J 1/10W		
R226			RK73FB2A101J	CHIP R 100 J 1/10W		
R227			RK73FB2A471J	CHIP R 470 J 1/10W		
R228, 229			RK73FB2A100J	CHIP R 10 J 1/10W		
R230			R92-0670-05	CHIP R 0 ΩHM		
R231			RK73FB2A333J	CHIP R 33K J 1/10W		
R232			RK73FB2A472J	CHIP R 4.7K J 1/10W		
R233			RK73FB2A123J	CHIP R 12K J 1/10W		
R234			RK73FB2A473J	CHIP R 47K J 1/10W		
R239			RK73FB2A102J	CHIP R 1.0K J 1/10W		
R240			RK73FB2A473J	CHIP R 47K J 1/10W		
R241			RK73FB2A102J	CHIP R 1.0K J 1/10W		
R242, 243			R92-0670-05	CHIP R 0 ΩHM		
R246-248			RK73FB2A102J	CHIP R 1.0K J 1/10W		
R249			RK73FB2A473J	CHIP R 47K J 1/10W		
R251-255			RK73FB2A473J	CHIP R 47K J 1/10W		
R256			RK73FB2A102J	CHIP R 1.0K J 1/10W		
R257-262			RK73FB2A473J	CHIP R 47K J 1/10W		
R264			RK73FB2A473J	CHIP R 47K J 1/10W		
R265			RK73FB2A391J	CHIP R 390 J 1/10W		
R266			RK73FB2A683J	CHIP R 68K J 1/10W		
R268			RK73FB2A101J	CHIP R 100 J 1/10W		
R272, 273			R92-0150-05	JUMPER REST 0 ΩHM		
R276, 277			R92-0670-05	CHIP R 0 ΩHM		
R279-281			R92-0670-05	CHIP R 0 ΩHM		
R301-303			RK73FB2A104J	CHIP R 100K J 1/10W		
R304			RK73FB2A223J	CHIP R 22K J 1/10W		
R305			RK73FB2A224J	CHIP R 220K J 1/10W		
R306			R92-0670-05	CHIP R 0 ΩHM		
R308			R92-0670-05	CHIP R 0 ΩHM		
R309			RK73FB2A103J	CHIP R 10K J 1/10W		
R310			RK73FB2A470J	CHIP R 47 J 1/10W		

L:Scandinavia

K:USA

P:Canada

Y:PX(Far East, Hawaii)

T:England

E:Europe

Y:AAFES(Europe)

X:Australia

M:Other Areas

▲ indicates safety critical components.

## PARTS LIST

× New Parts

Parts without Parts No. are not supplied.

Les articles non mentionnes dans le Parts No. ne sont pas fournis.

Teile ohne Parts No. werden nicht geliefert.

TX UNIT (X56-3020-11)

Ref. No. 参照番号	Address 位置	New Parts 新	Parts No. 部品番号	Description 部品名 / 規格	Desti- nation 仕 向	Re- marks 備考
VR101-103 VR104 VR105,106			R12-3132-05 R12-6018-05 R12-3132-05	TRIM POT. 47K , TRIM POT. 470K TRIM POT. 47K		
S201-203 S204			S79-0408-05 S40-2446-05	SWITCH (CH) PUSH SWITCH		
D101 D102 D103 D201,202 D204			1SV172 02CZ10(X,Y) 1SS184 1T33C B30-0838-05	DIODE DIODE DIODE DIODE LED		
D205 IC101 IC102 IC201 IC202			1SV164 M57781 KCA03 MB1501F TC4S584F	DIODE IC(POWER MODULE) IC(MIC AMP) IC(PLL FREQ SYNTHESIZER) IC(SCHMITT TRIGGER)		
IC202 IC203 IC204 IC205 IC206			SC14S584F UPD75008CU-134 M51943BML NJM78L08UA NJM78L05UA	IC(SCHMITT TRIGGER) IC(CPU) IC(SYSTEM RESET) IC(VOLTAGE REGULATOR/ +8V) IC(VOLTAGE REGULATOR/ +5V)		
IC207 IC301 Q101 Q102 Q103			NJM78L08UA TA75S01F 2SD1682(R,S) 2SB1119(S) DTC114EK	IC(VOLTAGE REGULATOR/ +8V) IC TRANSISTOR TRANSISTOR DIGITAL TRANSISTOR		
Q104 Q105 Q106 Q107 Q201-203			DTA114EK DTC114EK DTC114YK FMG5 2SC3356	DIGITAL TRANSISTOR DIGITAL TRANSISTOR DIGITAL TRANSISTOR TRANSISTOR TRANSISTOR		
Q204 Q205 Q206 Q207 Q208			2SC2712(Y) 2SK508NV(K52) 2SC3356 2SA1162(Y) DTC114EK	TRANSISTOR FET TRANSISTOR TRANSISTOR DIGITAL TRANSISTOR		
Q209 TH201			2SC2714(Y) 157-502-55007	TRANSISTOR THERMISTER(5K)		

L:Scandinavia

K:USA

P:Canada

Y:PX(Far East, Hawaii)

T:England

E:Europe

Y:AAFES(Europe)

X:Australia

M:Other Areas

 indicates safety critical components.

## EXPLODED VIEW

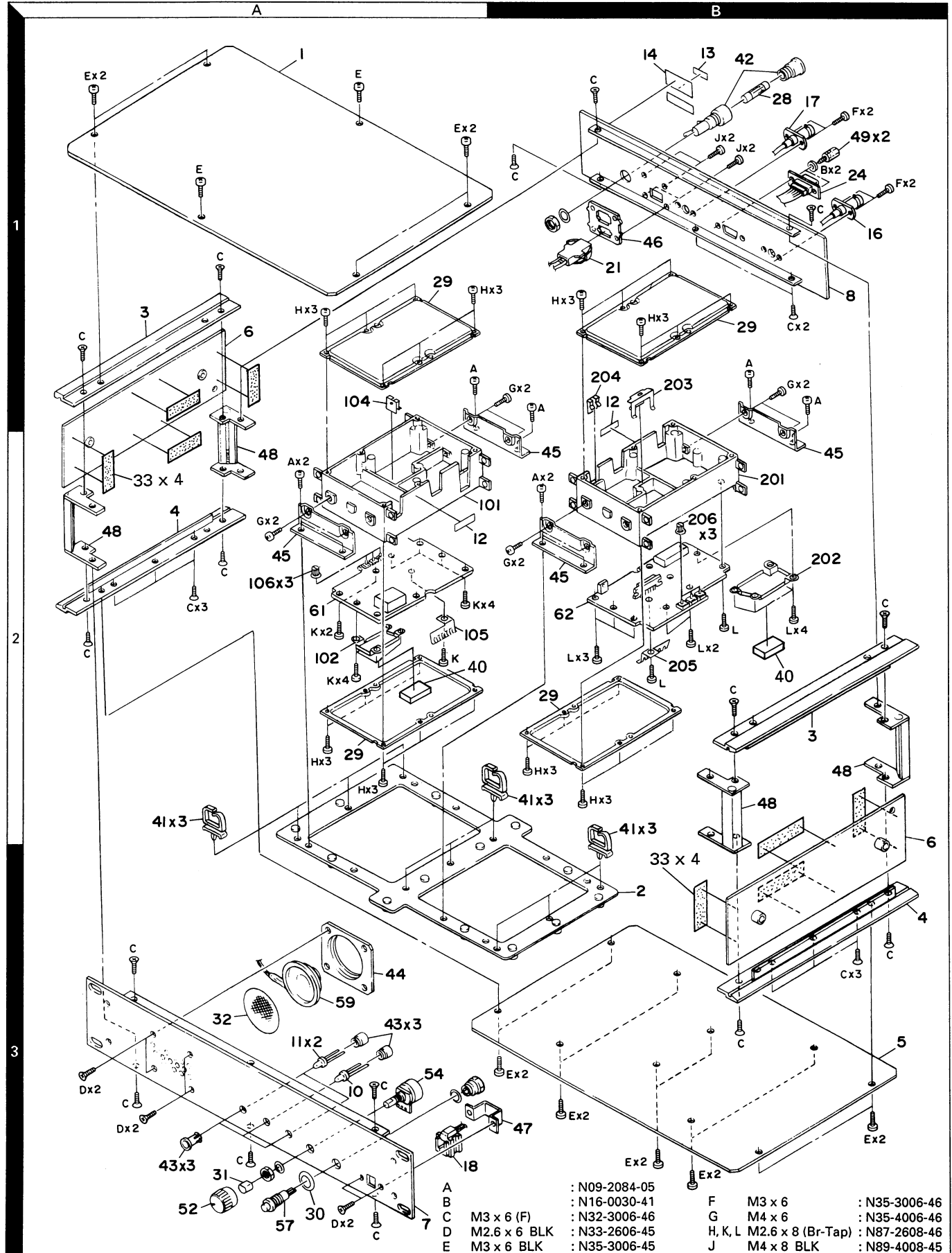

## PACKING

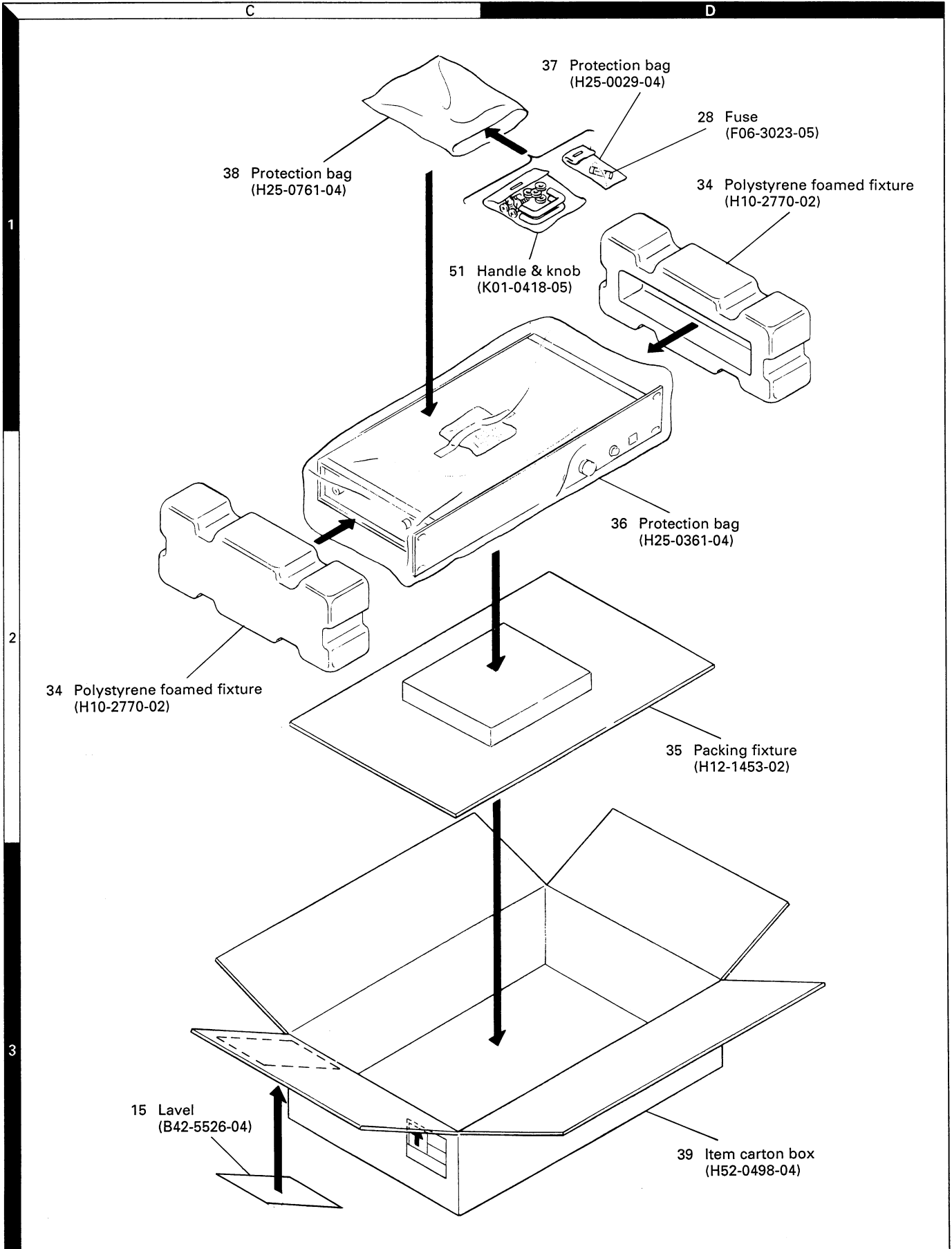

# ADJUSTMENT

## Test Equipment Required for Alignment

No.	Test Equipment	Major Specifications	
1	Standard Signal Generator (SSG)	Frequency Range Modulation Output	800 to 1000MHz. Frequency modulation and external modulation. 0.1 $\mu$ V to greater than 1mV.
2	Power Meter	Input Impedance Operation Frequency Measurement Capability	50 $\Omega$ . 800 to 1000MHz or more. Vicinity of 1W.
3	Deviation Meter	Frequency Range	800 to 1000MHz.
4	Digital Volt Meter (DVM)	Measuring Range Accuracy	1 to 20V DC. High input impedance for minimum circuit loading.
5	Oscilloscope		DC through 30MHz.
6	High Sensitivity Frequency Counter	Frequency Range Frequency Stability	10Hz to 1GHz. 0.02ppm or less.
7	Ammeter		3A.
8	AF Volt Meter (AFVTVM)	Frequency Range Voltage Range	50Hz to 10kHz. 3mV to 3V.
9	Audio Generator (AG)	Frequency Range Output	50Hz to 5kHz or more. 0 to 1V.
10	Distortion Meter	Capability Input Level	3% or less at 1kHz. 50mV to 10Vrms.
11	Voltmeter	Measuring Range Input Impedance	20 to 1.5V DC or less. 50k $\Omega$ /V or greater.

## The Following Parts are Required for Adjustment

- Test cable for local microphone

MIC connector  
front view

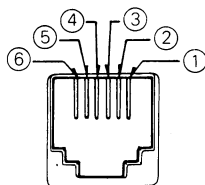

- ① NC
- ② PTTG
- ③ PTT
- ④ MICG
- ⑤ MIC
- ⑥ NC

- The following test cables are recommended.

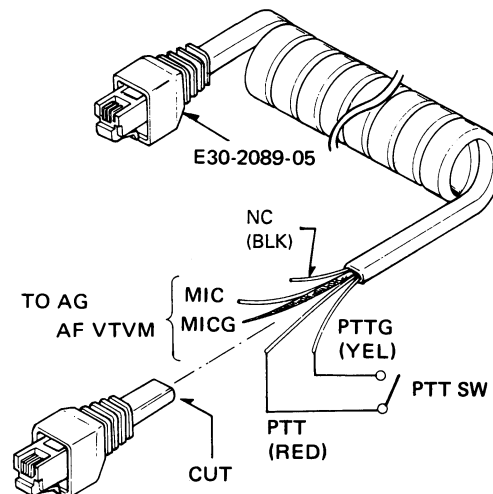

Test cable for Microphone input

- DC cable

Use the E30-2076-15 (DC cable assembly).

- D-SUB connector adapter (15-pin)

The connector is not provided as an option, so buy a commercially available one.

The TKR-901 is adjusted by applying input/output signals to each pin of the D-SUB connector. For details of pin functions, see the description of the logic interface connector (J304) in "Operating Features".

# TKR-901

## ADJUSTMENT

### Adjustment Location

- Top view

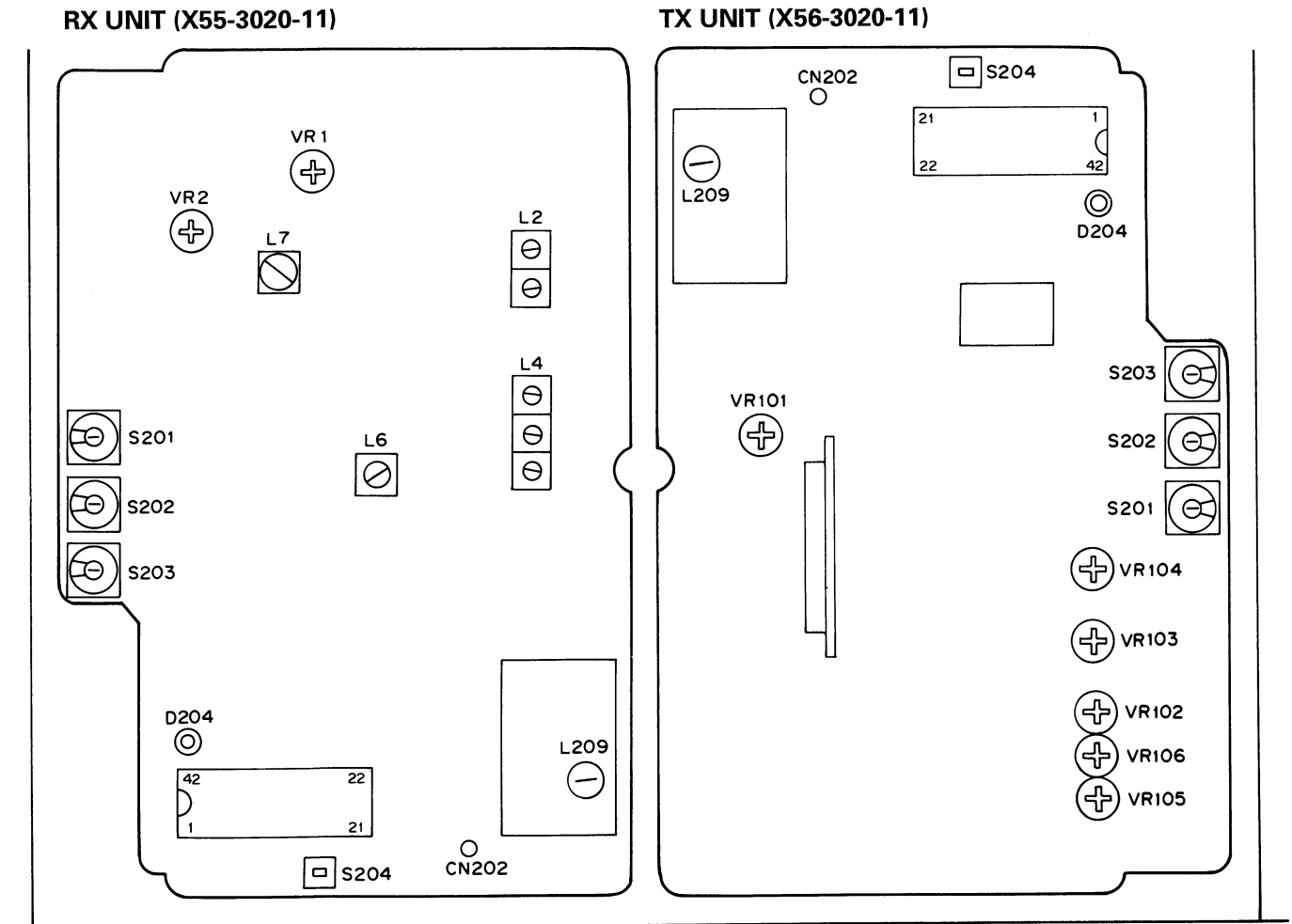

Front panel

VR1 : Squelch  
 VR2 : RX detector signal level  
 S201~203 : FCC channel (RX CH)  
 S204 : Reset switch  
 L2, 4 : BPF  
 L6, 7 : Distortion  
 L209 : RX PLL voltage  
 CN202 : RX PLL voltage output

VR101 : Power  
 VR102 : Maximum deviation  
 VR103 : Tone deviation  
 VR104 : Tone waveform  
 VR105 : System MIC sensitivity  
 VR106 : Local MIC sensitivity  
 S201~203 : FCC channel (TX CH)  
 S204 : Reset switch  
 L209 : TX PLL voltage  
 CN202 : TX PLL voltage output

## ADJUSTMENT

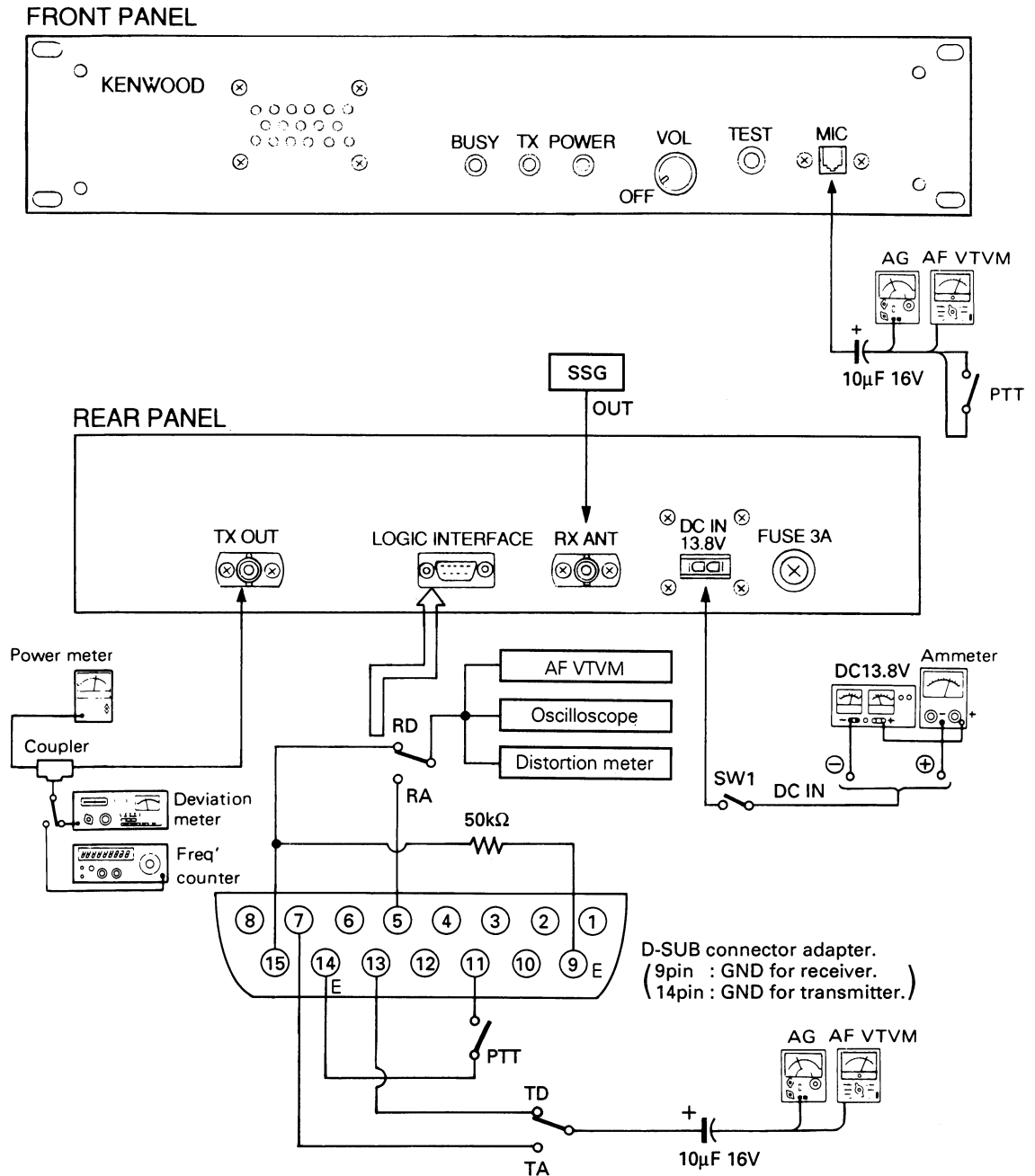

### Alignment

Item	Condition	Measurement			Adjustment			Specifications/Remarks
		Test-equipment	Unit	Terminal	Unit	Parts	Method	
1. Setting	1) VOL : OFF 2) Connect the test equipment. 3) Channel setting for used CH. (transmit and receive) 4) POWER SW (SW1) : ON							
2. TX PLL voltage	1) TEST SW : ON	DVM	TX	CN202	TX	L209	4.0V If 4.0V can not adjust, PLL voltage is adjust 2.0~4.0V (Low CH) or 4.0~6.0V (High CH).	±0.1V
3. Transmit frequency check	1) TEST SW : ON	Power meter f. counter					Check	frx ± 93Hz



# TKR-901

## ADJUSTMENT

Item	Condition	Measurement			Adjustment			Specifications/Remarks
		Test-equipment	Unit	Terminal	Unit	Parts	Method	
4. Power	1) Logic interface (11-PTT)	Power meter Ammeter	Rear panel	TX OUT	TX	VR101	360mW	±10mW, 1.5A or less.
5. TONE deviation	1) AG : 50Hz/0.5Vp-p square wave at logic interface (13-TD). Deviation meter filter HPF : OFF LPF : 3kHz Logic interface (11-PTT)	Power Deviation meter Oscilloscope	(D-SUB)			VR104	Make the demodulation waveform neat.	
	VR103					±0.75kHz	±0.05kHz	
6. Local MIC sensitivity	1) AG : 1kHz/25mV sine wave at MIC connector. Deviation meter filter HPF : OFF LPF : 15kHz PTT : ON (MIC connector PTT)		Rear panel Front panel			VR102	±1.7kHz Adjust one more than the other by switching between -P and +P.	±50Hz
	2) AG : 1kHz/2.5mV sine wave at MIC connector. Deviation meter filter HPF : OFF LPF : 15kHz PTT : ON (MIC connector PTT)					VR106	±0.75kHz	±50Hz
7. System MIC sensitivity	1) AG : 1kHz/140mV sine wave at logic interface (7-TA). Logic interface (11-PTT)					VR105	±0.75kHz	±50Hz
8. RX PLL voltage		DVM	RX	CN202	RX	L209	4.0V If 4.0V can not adjust, PLL voltage is adjust 2.0~4.0V (Low CH) or 4.0~6.0V (High CH).	±0.1V
9. Distortion	1) SSG output : 500μV/54dBμ/-53dBm (MOD : 1kHz, DEV : ±1.5kHz)	SSG AF VTVM Distortion meter Oscilloscope	Rear panel (D-SUB)	RX ANT Logic interface (5-RA)		L7	Adjust for maximum AF output.	
						L6	Adjust for minimum distortion.	Distortion : 3% or less
10. BPF	1) SSG output : 1.58μV/4dBμ/-103dBm (MOD : 1kHz, DEV : ±1.5kHz)					L2, 4	Adjust for maximum SINAD.	
11. Sensitivity	1) SSG output : 0.3μV/-10.5dBμ/-117.5dBm (MOD : 1kHz, DEV : ±1.5kHz)						Check	SINAD 12dB or more.
12. Squelch	1) SSG output : Value when 5dB is subtracted from the sensitivity value of 12dB SINAD. (MOD : 1kHz, DEV : ±1.5kHz)				RX	VR1	Set to threshold point.	Squelch close.
	2) SSG output : 12dB SINAD -3dBm						Check	Squelch open.
	3) SSG output : OFF							squelch close.
13. RX detector signal output	1) SSG output : 500μV/54dBμ/-53dBm (MOD : 1kHz, DEV : ±1.5kHz)	SSG AF VTVM Oscilloscope 50kΩ dummy load	Rear panel	RX ANT Logic interface (15-RD)	RX	VR2	80mV/50kΩ	±5mV
14. Power consumption	1) SSG output : OFF	SSG Ammeter					Check	Power consumption 0.5A or less.

## CHANNEL FREQUENCY CHART

FCC Chan.	Transmit (MHz)	Receive (MHz)
1	935.0125	896.0125
2	935.0250	896.0250
3	935.0375	896.0375
4	935.0500	896.0500
5	935.0625	896.0625
6	935.0750	896.0750
7	935.0875	896.0875
8	935.1000	896.1000
9	935.1125	896.1125
10	935.1250	896.1250
11	935.1375	896.1375
12	935.1500	896.1500
13	935.1625	896.1625
14	935.1750	896.1750
15	935.1875	896.1875
16	935.2000	896.2000
17	935.2125	896.2125
18	935.2250	896.2250
19	935.2375	896.2375
20	935.2500	896.2500
21	935.2625	896.2625
22	935.2750	896.2750
23	935.2875	896.2875
24	935.3000	896.3000
25	935.3125	896.3125
26	935.3250	896.3250
27	935.3375	896.3375
28	935.3500	896.3500
29	935.3625	896.3625
30	935.3750	896.3750
31	935.3875	896.3875
32	935.4000	896.4000
33	935.4125	896.4125
34	935.4250	896.4250
35	935.4375	896.4375
36	935.4500	896.4500
37	935.4625	896.4625
38	935.4750	896.4750
39	935.4875	896.4875
40	935.5000	896.5000
41	935.5125	896.5125
42	935.5250	896.5250
43	935.5375	896.5375
44	935.5500	896.5500
45	935.5625	896.5625
46	935.5750	896.5750
47	935.5875	896.5875
48	935.6000	896.6000
49	935.6125	896.6125
50	935.6250	896.6250
51	935.6375	896.6375
52	935.6500	896.6500
53	935.6625	896.6625
54	935.6750	896.6750

FCC Chan.	Transmit (MHz)	Receive (MHz)
55	935.6875	896.6875
56	935.7000	896.7000
57	935.7125	896.7125
58	935.7250	896.7250
59	935.7375	896.7375
60	935.7500	896.7500
61	935.7625	896.7625
62	935.7750	896.7750
63	935.7875	896.7875
64	935.8000	896.8000
65	935.8125	896.8125
66	935.8250	896.8250
67	935.8375	896.8375
68	935.8500	896.8500
69	935.8625	896.8625
70	935.8750	896.8750
71	935.8875	896.8875
72	935.9000	896.9000
73	935.9125	896.9125
74	935.9250	896.9250
75	935.9375	896.9375
76	935.9500	896.9500
77	935.9625	896.9625
78	935.9750	896.9750
79	935.9875	896.9875
80	936.0000	897.0000
81	936.0125	897.0125
82	936.0250	897.0250
83	936.0375	897.0375
84	936.0500	897.0500
85	936.0625	897.0625
86	936.0750	897.0750
87	936.0875	897.0875
88	936.1000	897.1000
89	936.1125	897.1125
90	936.1250	897.1250
91	936.1375	897.1375
92	936.1500	897.1500
93	936.1625	897.1625
94	936.1750	897.1750
95	936.1875	897.1875
96	936.2000	897.2000
97	936.2125	897.2125
98	936.2250	897.2250
99	936.2375	897.2375
100	936.2500	897.2500
101	936.2625	897.2625
102	936.2750	897.2750
103	936.2875	897.2875
104	936.3000	897.3000
105	936.3125	897.3125
106	936.3250	897.3250
107	936.3375	897.3375
108	936.3500	897.3500

## CHANNEL FREQUENCY CHART

FCC Chan.	Transmit (MHz)	Receive (MHz)
109	936.3625	897.3625
110	936.3750	897.3750
111	936.3875	897.3875
112	936.4000	897.4000
113	936.4125	897.4125
114	936.4250	897.4250
115	936.4375	897.4375
116	936.4500	897.4500
117	936.4625	897.4625
118	936.4750	897.4750
119	936.4875	897.4875
120	936.5000	897.5000
121	936.5125	897.5125
122	936.5250	897.5250
123	936.5375	897.5375
124	936.5500	897.5500
125	936.5625	897.5625
126	936.5750	897.5750
127	936.5875	897.5875
128	936.6000	897.6000
129	936.6125	897.6125
130	936.6250	897.6250
131	936.6375	897.6375
132	936.6500	897.6500
133	936.6625	897.6625
134	936.6750	897.6750
135	936.6875	897.6875
136	936.7000	897.7000
137	936.7125	897.7125
138	936.7250	897.7250
139	936.7375	897.7375
140	936.7500	897.7500
141	936.7625	897.7625
142	936.7750	897.7750
143	936.7875	897.7875
144	936.8000	897.8000
145	936.8125	897.8125
146	936.8250	897.8250
147	936.8375	897.8375
148	936.8500	897.8500
149	936.8625	897.8625
150	936.8750	897.8750
151	936.8875	897.8875
152	936.9000	897.9000
153	936.9125	897.9125
154	936.9250	897.9250
155	936.9375	897.9375
156	936.9500	897.9500
157	936.9625	897.9625
158	936.9750	897.9750
159	936.9875	897.9875
160	937.0000	898.0000
161	937.0125	898.0125
162	937.0250	898.0250

FCC Chan.	Transmit (MHz)	Receive (MHz)
163	937.0375	898.0375
164	937.0500	898.0500
165	937.0625	898.0625
166	937.0750	898.0750
167	937.0875	898.0875
168	937.1000	898.1000
169	937.1125	898.1125
170	937.1250	898.1250
171	937.1375	898.1375
172	937.1500	898.1500
173	937.1625	898.1625
174	937.1750	898.1750
175	937.1875	898.1875
176	937.2000	898.2000
177	937.2125	898.2125
178	937.2250	898.2250
179	937.2375	898.2375
180	937.2500	898.2500
181	937.2625	898.2625
182	937.2750	898.2750
183	937.2875	898.2875
184	937.3000	898.3000
185	937.3125	898.3125
186	937.3250	898.3250
187	937.3375	898.3375
188	937.3500	898.3500
189	937.3625	898.3625
190	937.3750	898.3750
191	937.3875	898.3875
192	937.4000	898.4000
193	937.4125	898.4125
194	937.4250	898.4250
195	937.4375	898.4375
196	937.4500	898.4500
197	937.4625	898.4625
198	937.4750	898.4750
199	937.4875	898.4875
200	937.5000	898.5000
201	937.5125	898.5125
202	937.5250	898.5250
203	937.5375	898.5375
204	937.5500	898.5500
205	937.5625	898.5625
206	937.5750	898.5750
207	937.5875	898.5875
208	937.6000	898.6000
209	937.6125	898.6125
210	937.6250	898.6250
211	937.6375	898.6375
212	937.6500	898.6500
213	937.6625	898.6625
214	937.6750	898.6750
215	937.6875	898.6875
216	937.7000	898.7000

## CHANNEL FREQUENCY CHART

FCC Chan.	Transmit (MHz)	Receive (MHz)
217	937.7125	898.7125
218	937.7250	898.7250
219	937.7375	898.7375
220	937.7500	898.7500
221	937.7625	898.7625
222	937.7750	898.7750
223	937.7875	898.7875
224	937.8000	898.8000
225	937.8125	898.8125
226	937.8250	898.8250
227	937.8375	898.8375
228	937.8500	898.8500
229	937.8625	898.8625
230	937.8750	898.8750
231	937.8875	898.8875
232	937.9000	898.9000
233	937.9125	898.9125
234	937.9250	898.9250
235	937.9375	898.9375
236	937.9500	898.9500
237	937.9625	898.9625
238	937.9750	898.9750
239	937.9875	898.9875
240	938.0000	899.0000
241	938.0125	899.0125
242	938.0250	899.0250
243	938.0375	899.0375
244	938.0500	899.0500
245	938.0625	899.0625
246	938.0750	899.0750
247	938.0875	899.0875
248	938.1000	899.1000
249	938.1125	899.1125
250	938.1250	899.1250
251	938.1375	899.1375
252	938.1500	899.1500
253	938.1625	899.1625
254	938.1750	899.1750
255	938.1875	899.1875
256	938.2000	899.2000
257	938.2125	899.2125
258	938.2250	899.2250
259	938.2375	899.2375
260	938.2500	899.2500
261	938.2625	899.2625
262	938.2750	899.2750
263	938.2875	899.2875
264	938.3000	899.3000
265	938.3125	899.3125
266	938.3250	899.3250
267	938.3375	899.3375
268	938.3500	899.3500
269	938.3625	899.3625
270	938.3750	899.3750

FCC Chan.	Transmit (MHz)	Receive (MHz)
271	938.3875	899.3875
272	938.4000	899.4000
273	938.4125	899.4125
274	938.4250	899.4250
275	938.4375	899.4375
276	938.4500	899.4500
277	938.4625	899.4625
278	938.4750	899.4750
279	938.4875	899.4875
280	938.5000	899.5000
281	938.5125	899.5125
282	938.5250	899.5250
283	938.5375	899.5375
284	938.5500	899.5500
285	938.5625	899.5625
286	938.5750	899.5750
287	938.5875	899.5875
288	938.6000	899.6000
289	938.6125	899.6125
290	938.6250	899.6250
291	938.6375	899.6375
292	938.6500	899.6500
293	938.6625	899.6625
294	938.6750	899.6750
295	938.6875	899.6875
296	938.7000	899.7000
297	938.7125	899.7125
298	938.7250	899.7250
299	938.7375	899.7375
300	938.7500	899.7500
301	938.7625	899.7625
302	938.7750	899.7750
303	938.7875	899.7875
304	938.8000	899.8000
305	938.8125	899.8125
306	938.8250	899.8250
307	938.8375	899.8375
308	938.8500	899.8500
309	938.8625	899.8625
310	938.8750	899.8750
311	938.8875	899.8875
312	938.9000	899.9000
313	938.9125	899.9125
314	938.9250	899.9250
315	938.9375	899.9375
316	938.9500	899.9500
317	938.9625	899.9625
318	938.9750	899.9750
319	938.9875	899.9875
320	939.0000	900.0000
321	939.0125	900.0125
322	939.0250	900.0250
323	939.0375	900.0375
324	939.0500	900.0500

# TKR-901

## CHANNEL FREQUENCY CHART

FCC Chan.	Transmit (MHz)	Receive (MHz)
325	939.0625	900.0625
326	939.0750	900.0750
327	939.0875	900.0875
328	939.1000	900.1000
329	939.1125	900.1125
330	939.1250	900.1250
331	939.1375	900.1375
332	939.1500	900.1500
333	939.1625	900.1625
334	939.1750	900.1750
335	939.1875	900.1875
336	939.2000	900.2000
337	939.2125	900.2125
338	939.2250	900.2250
339	939.2375	900.2375
340	939.2500	900.2500
341	939.2625	900.2625
342	939.2750	900.2750
343	939.2875	900.2875
344	939.3000	900.3000
345	939.3125	900.3125
346	939.3250	900.3250
347	939.3375	900.3375
348	939.3500	900.3500
349	939.3625	900.3625
350	939.3750	900.3750
351	939.3875	900.3875
352	939.4000	900.4000
353	939.4125	900.4125
354	939.4250	900.4250
355	939.4375	900.4375
356	939.4500	900.4500
357	939.4625	900.4625
358	939.4750	900.4750
359	939.4875	900.4875
360	939.5000	900.5000
361	939.5125	900.5125
362	939.5250	900.5250

FCC Chan.	Transmit (MHz)	Receive (MHz)
363	939.5375	900.5375
364	939.5500	900.5500
365	939.5625	900.5625
366	939.5750	900.5750
367	939.5875	900.5875
368	939.6000	900.6000
369	939.6125	900.6125
370	939.6250	900.6250
371	939.6375	900.6375
372	939.6500	900.6500
373	939.6625	900.6625
374	939.6750	900.6750
375	939.6875	900.6875
376	939.7000	900.7000
377	939.7125	900.7125
378	939.7250	900.7250
379	939.7375	900.7375
380	939.7500	900.7500
381	939.7625	900.7625
382	939.7750	900.7750
383	939.7875	900.7875
384	939.8000	900.8000
385	939.8125	900.8125
386	939.8250	900.8250
387	939.8375	900.8375
388	939.8500	900.8500
389	939.8625	900.8625
390	939.8750	900.8750
391	939.8875	900.8875
392	939.9000	900.9000
393	939.9125	900.9125
394	939.9250	900.9250
395	939.9375	900.9375
396	939.9500	900.9500
397	939.9625	900.9625
398	939.9750	900.9750
399	939.9875	900.9875

## RX UNIT (X55-3020-11) Component side view

## RX UNIT (X55-3020-11) Foil side view

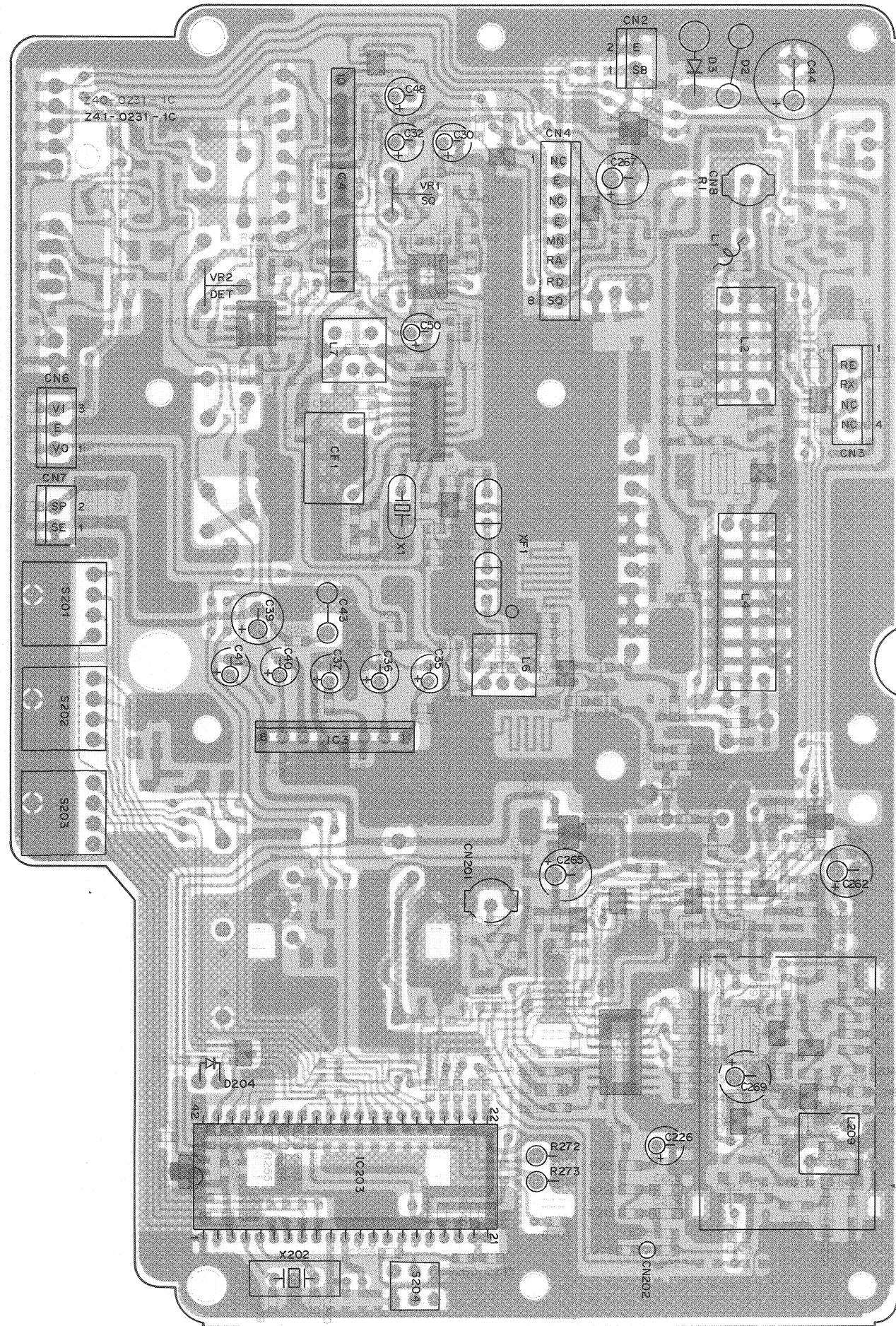

2SA1162  
2SC2712  
2SC2714  
2SC3356  
DTC114EK  
DTC114YK



2SC4093  
3SK184



2SK508NV



FMG5



NJM78L05UA  
NJM78L08UA  
M51943BML



TC4S66F

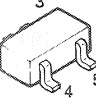

TC4S584F

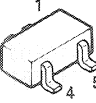

NJM4558M

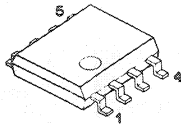

MC3371D  
MB1501F

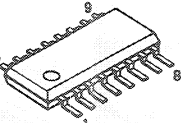

$\mu$ PC1241H

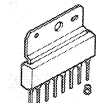

$\mu$ PD75008CU-134

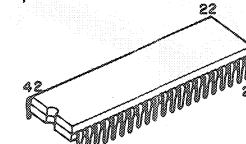

: Component side  
 : Foil side

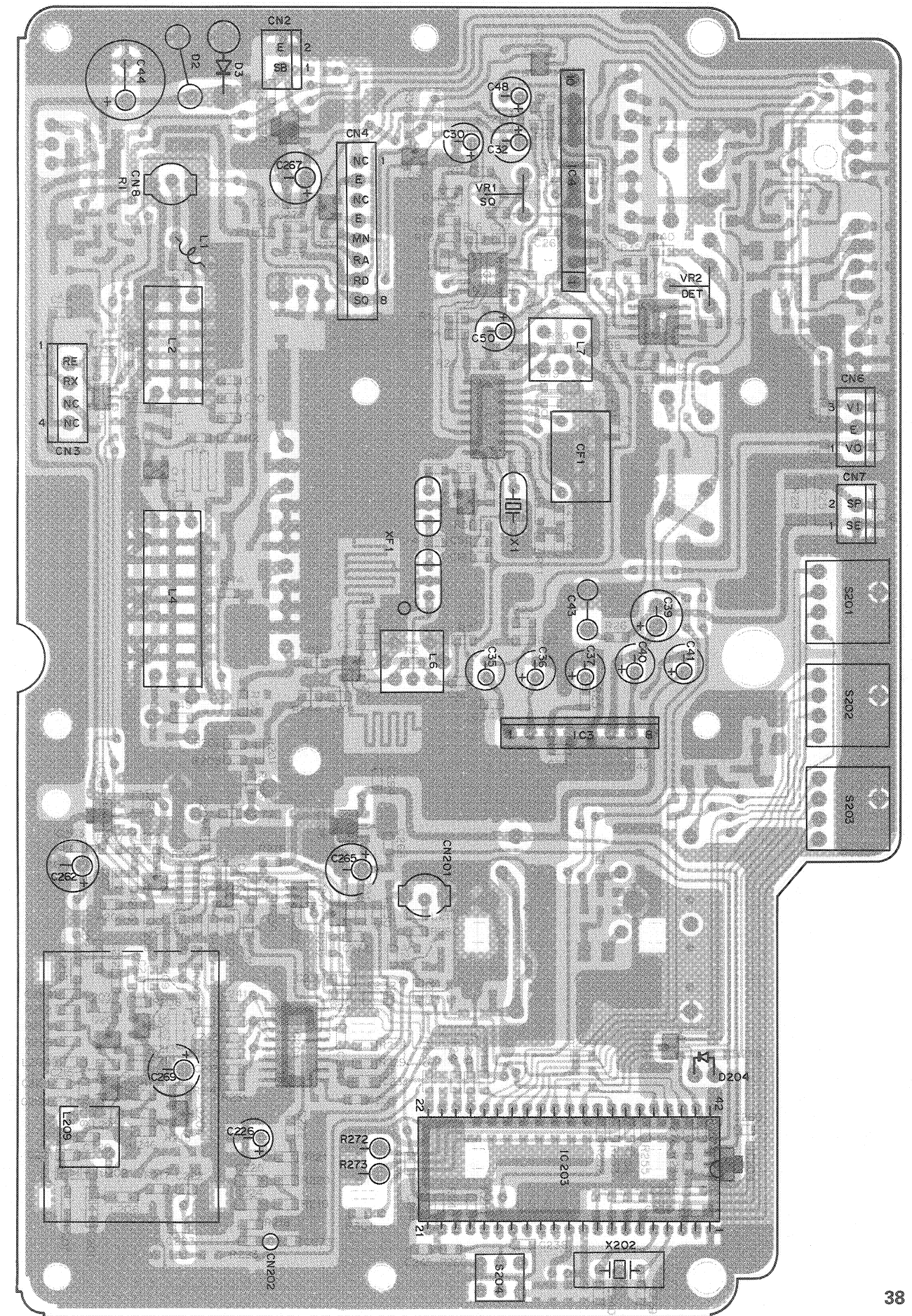





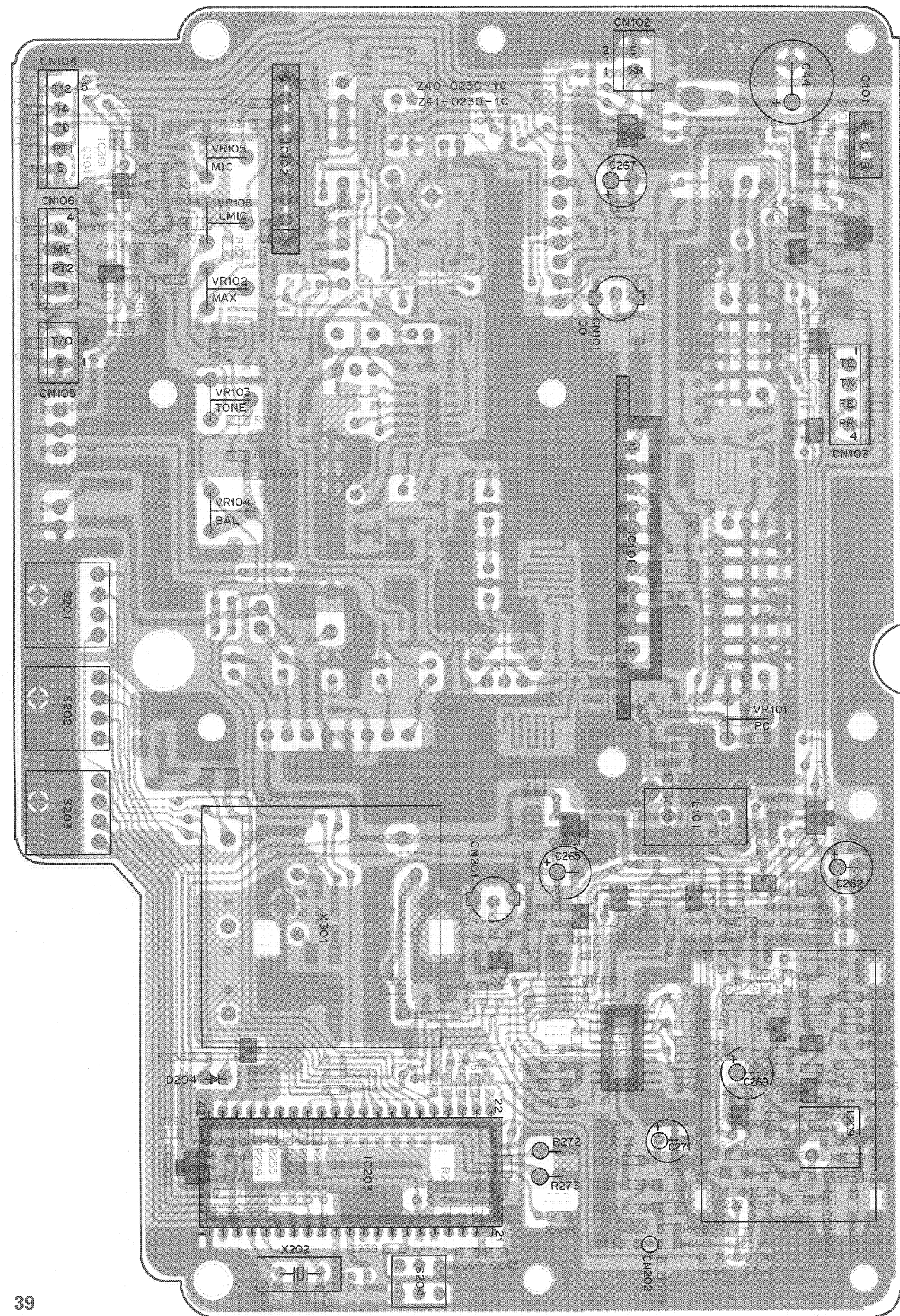

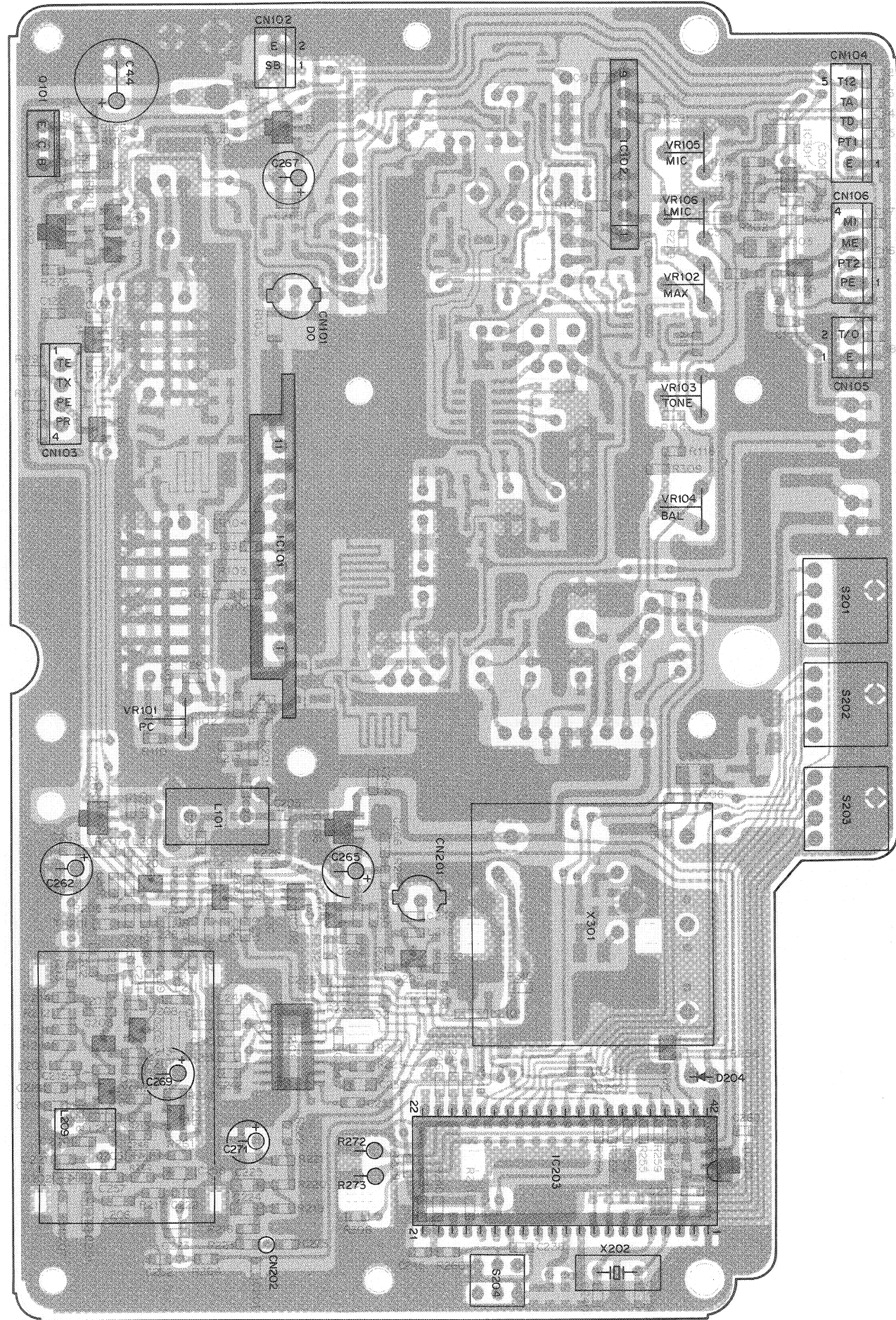

# TKR-901 PC BOARD VIEWS

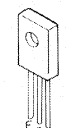

TX UNIT (X56-3020-11) Component side view



TX UNIT (X56-3020-11) Foil side view

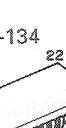

- 2SD1682 
- 2SA1162
- 2SC2712
- 2SC2714
- 2SC3356
- DTA114EK
- DTC114EK
- DTC114YK
- 2SB1119 
- 2SK508NV 
- FMG5 
- M57781 
- TA75S01F
- TC4S584F 
- NJM78L05UA
- NJM78L08UA
- M51943BML 
- MB1501F 
- μPD75008CU-134 

 : Component side  
 : Foil side

# SCHEMATIC DIAGRAM TKR-901

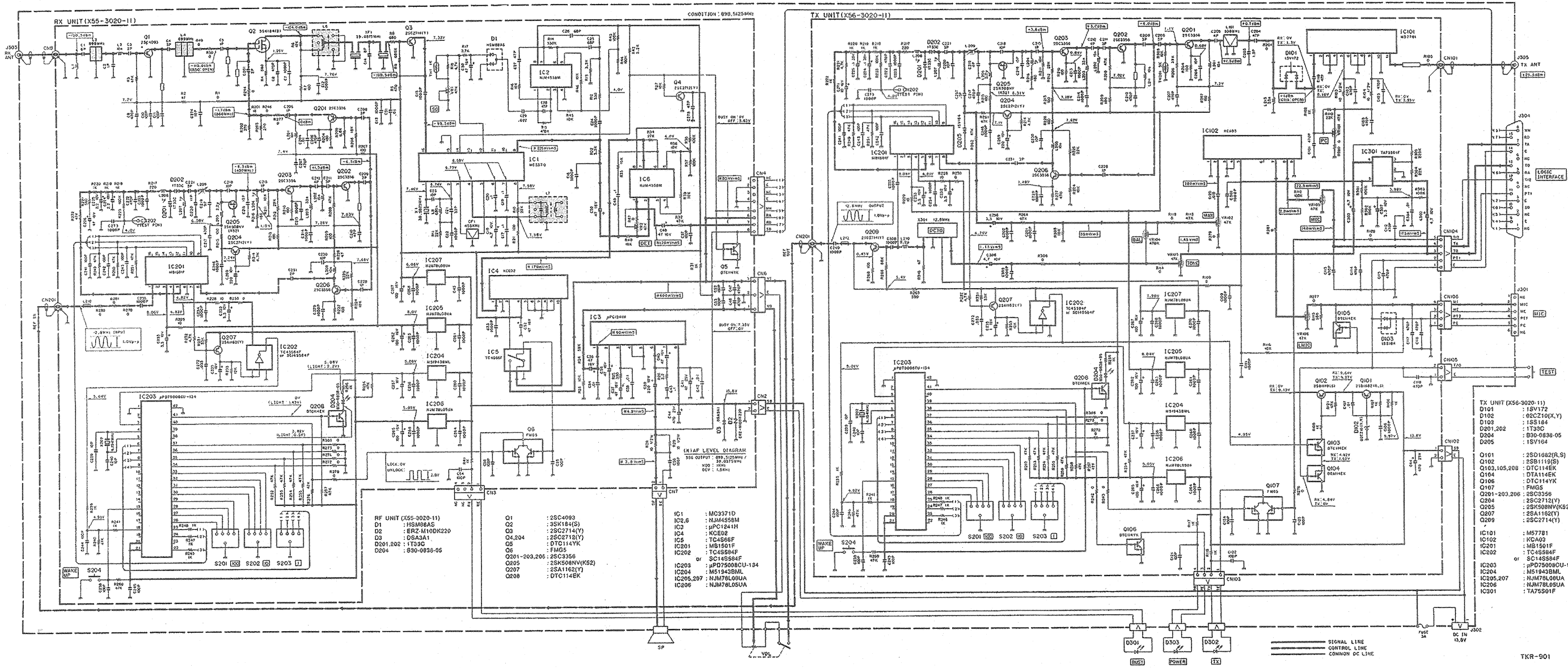

- RF UNIT (X55-3020-11)  
 D1 : 1S188AD  
 D2 : ER2-M10DK220  
 D3 : DSAS31  
 D201,202 : 1T30C  
 D204 : 830-0830-05
- Q1 : 2SC4093  
 Q2 : 2SK184(S)  
 Q3 : 2SC2714(Y)  
 Q4,204 : 2SC2712(Y)  
 Q5 : DTC114YK  
 Q6 : 7MG5  
 Q201-203,206 : 2SC3356  
 Q205 : 2SK508NV(K92)  
 Q207 : SA1152(Y)  
 Q208 : DTC114EK
- IC1 : MC3371D  
 IC2,6 : NJM4558M  
 IC3 : μPC1241H  
 IC4 : KC62  
 IC5 : TC4566F  
 IC201 : MB1501F  
 IC202 : TC45584F  
 or SC14584F  
 IC203 : μPD7508BU-134  
 IC204 : MS1943BML  
 IC205,207 : NJM78L05UA  
 IC206 : NJM78L05UA  
 IC301 : TA75501F

- TX UNIT (X56-3020-11)  
 D101 : 1S1172  
 D102 : 02C210(X,Y)  
 D109 : 1SS184  
 D201,202 : 1T30C  
 D204 : 830-0830-05  
 D205 : 1SV164
- Q101 : 2SD1682(R,S)  
 Q102 : 2SB1119(S)  
 Q103,105,208 : DTC114EK  
 Q104 : DTC114EK  
 Q106 : DTC114YK  
 Q107 : 7MG5  
 Q201-203,206 : 2SC3356  
 Q204 : 2SC2712(Y)  
 Q205 : 2SK508NV(K92)  
 Q207 : 2SA1152(Y)  
 Q209 : 2SC2714(Y)
- IC101 : M57781  
 IC102 : KA403  
 IC201 : MB1501F  
 IC202 : TC45584F  
 or SC14584F  
 IC203 : μPD7508BU-134  
 IC204 : MS1943BML  
 IC205,207 : NJM78L05UA  
 IC206 : NJM78L05UA  
 IC301 : TA75501F



# TKR-901

## TERMINAL FUNCTION

Connector No.	Terminal No.	Terminal Name	I/O	Terminal function
<b>RX UNIT (X55-3020-11)</b>				
CN2 For fuse	1	SB	I	Power supply input (13.8V ±20%).
	2	E	-	GND.
CN3 For LED	1	RE	I	ON when RX.
	2	RX	O	13.8V.
	3	NC	-	Not use.
	4	NC	-	Not use.
CN4 For LOGIC INTERFACE	1	NC	-	Not use.
	2	E	-	GND.
	3	NC	-	Not use.
	4	E	-	GND.
	5	MN	I	Monitor switch (ON when monitor).
	6	RA	O	RX audio signal output (400mV at high impedance).
	7	RD	O	RX detector signal output (80mV/50kΩ).
	8	SQ	O	Squelch signal output (open when "L").
CN6 For VOL	1	VO	O	Audio signal output (500mV at high impedance).
	2	E	-	GND.
	3	VI	I	Audio signal input.
CN7	1	SE	-	GND.
	2	SP	O	Audio signal output (VOL ON).
CN8	1	RI	I	Receiver signal input (0.3μV).
CN201	1	REF	I	Reference signal input (12.8MHz).
CN202	1	TP	O	Look test port (4.0V).
<b>TX UNIT (X56-3020-11)</b>				
CN101	1	TX OUT	O	Transmission RF output (360mW).
CN102	1	SB	I	Power supply input (13.8V ±20%).
	2	E	-	GND.
CN103	1	TE	I	TX LED (ON when TX).
	2	TX	O	13.8V.
	3	PE	I	Power LED (ON when DC connected).
	4	PR	O	13.8V.
CN104	1	E	-	GND.
	2	PT1	I	PTT signal input.
	3	TD	I	TX tone signal input (0.5Vp-p).
	4	TA	I	TX modulation signal input (0.75kHz/140mV).
	5	T12	O	10V.
CN105	1	E	-	GND.
	2	T/O	I	PTT signal input (TX when push ON).
CN106 For MIC JACK	1	PE	-	GND.
	2	PT2	I	PTT signal input.
	3	ME	-	GND.
	4	MI	I	Modulation signal input (0.75kHz/2.5mV).
CN201	1	REF	O	Reference signal output (12.8MHz).
CN202	1	TP	O	Lock test port (4.0V).



# TKR-901

## SPECIFICATIONS

### GENERAL

Frequency range .....	RX : 896.0125 ~ 900.9875MHz
	TX : 935.0125 ~ 939.9875MHz
Input voltage .....	13.8V DC negative ground
Temperature range .....	-22°F to 140°F (-30°C to 60°C)
Frequency stability .....	±0.00001%
Antenna impedance .....	50Ω
Channel spacing .....	12.5kHz (PLL channel step 12.5kHz)
Duty cycle .....	100%
Dimensions (not including protusions) .....	19.00" (482.6mm) W x 3.46" (88mm) H x 10.24" (260mm) D

### RECEIVER

Sensitivity (EIA 12dB SINAD) .....	0.3μV
Selectivity .....	-70dB
Modulation acceptance .....	±3.5kHz
Spurious and image rejection .....	-80dB
Intermodulation .....	-70dB
Frequency stability .....	±0.00001%

### TRANSMITTER

RF power output .....	340 ~ 380mW
Modulation .....	11KOF1D, 11KOF3E
Audio distortion .....	Less than 5%

The TKR-901 incorporates a heater type crystal oscillator for the clock pulse oscillator circuit ; consequently, stabilization requires 15 minutes. Keep this in mind when operating this equipment.

## KENWOOD CORPORATION

Alive Mitake, 2-5, Shibuya 1-chome, Shibuya-ku, Tokyo 150, Japan

### KENWOOD SERVICE CORPORATION

P.O. BOX 22745, 2201 East Dominguez Street, Long Beach, CA 90801-5745, U.S.A.

### KENWOOD ELECTRONICS DEUTSCHLAND GMBH

Rembrücker Str. 15, 6056 Heusenstamm, Germany

### KENWOOD ELECTRONICS BENELUX N.V.

Mechelsesteenweg 418 B-1930 Zaventem, Belgium

### TRIO-KENWOOD FRANCE S.A.

13, Boulevard Ney, 75018 Paris, France

### TRIO-KENWOOD U.K. LIMITED

KENWOOD House, Dwight Road, Watford, Herts., WD1 8EB United Kingdom

### KENWOOD ELECTRONICS NEDERLAND B.V.

Amsterdamseweg 35, 1422 AC Uithoorn, The Netherlands

### KENWOOD ELECTRONICS ITALIA S.p.A.

Via G. Sirtori, 7/9 20129 Milano, Italy

### KENWOOD ESPAÑA S.A.

Bolivia, 239-08020 Barcelona, Spain

### KENWOOD ELECTRONICS AUSTRALIA PTY. LTD.

(A.C.N. 001 499 074)

P.O. Box 504, 8 Figtree Drive, Australia Centre, Homebush, N.S.W. 2140, Australia

### KENWOOD & LEE ELECTRONICS, LTD.

Unit 3712-3724, Level 37, Tower one Metroplaza, 223 Hing Fong Road, Kwai Fong, N.T., Hong Kong

### KENWOOD ELECTRONICS CANADA INC.

6070 Kestrel Road, Mississauga, Ontario, Canada L5T 1S8

## Free Manuals Download Website

<http://myh66.com>

<http://usermanuals.us>

<http://www.somanuals.com>

<http://www.4manuals.cc>

<http://www.manual-lib.com>

<http://www.404manual.com>

<http://www.luxmanual.com>

<http://aubethermostatmanual.com>

Golf course search by state

<http://golfingnear.com>

Email search by domain

<http://emailbydomain.com>

Auto manuals search

<http://auto.somanuals.com>

TV manuals search

<http://tv.somanuals.com>