

KENWOOD

STEREO AMPLIFIER
Model TL-9200

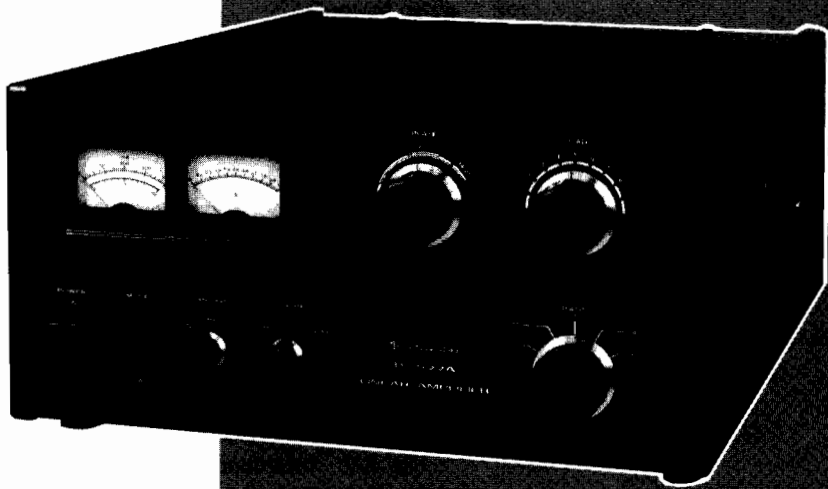

AFTER UNPACKING

It is advisable to save all original packing cartons (inner and outer) to protect your valuable Linear Amplifier from damage should you wish to transport it for remote operation or ship it for after-sales service.

The following explicit definitions apply in this manual. Be sure to read these definitions:

NOTE = If disregarded, inconvenience only — no damage or personal injury.

CAUTION = equipment damage may occur, but not personal injury.

WARNING = personal injury may occur — do not disregard.

CONTENTS

| | |
|---|-----------|
| TL-922A SPECIFICATIONS | 3 |
| SECTION 1 FEATURES | 4 |
| SECTION 2 PREPARATION FOR USE | 5 |
| 2.1 Accessories | |
| 2.2 Installation of Power Tubes | |
| 2.3 General Tips on Installation | |
| 2.4 AC Power Source | |
| 2.5 Line Voltage Change | |
| 2.6 Power Cable | |
| 2.7 Exciter | |
| 2.8 Antenna | |
| 2.9 Interconnection | |
| 2.9.1 Grounding | |
| 2.9.2 Cable Connection | |
| SECTION 3 CONTROLS AND THEIR FUNCTIONS . | 9 |
| 3.1 Front Panel | |
| 3.2 Rear Panel | |
| SECTION 4 OPERATION | 11 |
| 4.1 Prechecks | |
| 4.2 CW Operation | |
| 4.3 SSB Operation | |
| 4.4 RTTY Operation | |
| 4.5 Setting the ALC ADJ Control | |
| 4.6 Adjusting the RF Output Meter | |
| 4.7 High-Voltage Transformer Protection | |
| 4.8 Carrying Your TL-922A | |
| SECTION 5 CIRCUIT DESCRIPTION | 13 |
| 5.1 Linear Power Amplifier | |
| 5.2 Power Supply | |
| 5.3 Fan Motor Delay Stop Circuit | |
| 5.4 Meter Drive Circuit | |
| 5.5 Spark Suppressor | |

CAUTION

Read Operating Manual Section 2 before proceeding to unpack and assemble your amplifier.

WARNING

LETHAL VOLTAGES PRESENT.

| | |
|--|-----------|
| SECTION 6 MAINTENANCE | 15 |
| 6.1 Internal Cleaning | |
| 6.2 Replacing Power Fuses | |
| 6.3 Replacing Power Tubes | |
| 6.4 Input Matching Circuit | |
| SECTION 7 TROUBLESHOOTING HINTS | 16 |
| PACKING | 17 |
| INTERNAL PART LOCATIONS | 18 |
| SCHEMATIC DIAGRAM | 19 |

ILLUSTRATIONS

| | |
|---|----|
| Fig. 2-1 Upper Case Cover Assembly/ Disassembly | 5 |
| Fig. 2-2 Correct Power Tube Handling | 5 |
| Fig. 2-3 Parasitic Suppressor Coil Mounting | 6 |
| Fig. 2-4 Input Voltage Terminal Boards | 7 |
| Fig. 2-5 Power Cable Color Code | 8 |
| Fig. 2-6 Exciter Connections for RL and ALC Controls | 8 |
| Fig. 2-7 Interconnection of the TL-922A | 8 |
| Fig. 3-1 Front View | 9 |
| Fig. 3-2 Rear View | 10 |
| Fig. 5-1 Linear Power Amplifier Circuit | 13 |
| Fig. 5-2 Transformer Primary Current Flow | 14 |
| Fig. 5-3 Fan Motor Delay Stop Circuit | 14 |
| Fig. 5-4 Meter Drive Circuit | 14 |
| Fig. 7-1 Packing for Shipment | 17 |
| Fig. 7-2,3 Top, Bottom Views | 18 |

TABLES

| | |
|---|----|
| 1. Front Panel Controls Set-Up | 11 |
| 2. Tune and Load Initial Settings | 11 |

TL-922A SPECIFICATIONS

| | |
|--|---|
| Transmit Frequency Range: | 160m through 15m Amateur Bands |
| Excitation Energy Required: | 80 W nominal, 120 W maximum |
| Mode and Duty Cycle: | SSB, continuous for 30 minutes. CW and RTTY, key-down continuous for 10 minutes. |
| Rated Plate Input: | 2 kW P.E.P. SSB, 1 kW CW RTTY |
| Plate Voltage: (at No signal) | 3.1 kV SSB, 2.2 kV CW RTTY |
| Circuit Type: | Class AB2 grounded grid linear amplifier |
| 3rd Order Intermodulation Distortion: | Below -30dB. |
| Input Impedance: | 50 Ω , unbalanced at better than 1.5 SWR |
| Output Impedance: | 50 to 75 Ω , unbalanced. |
| Cooling: | Forced Air. |
| Interlock Safety Features: | Primary high voltage circuit cut-off. Secondary high-voltage circuit grounding. |
| Thermal Protector: | Locks out transmit relays if H.V. power transformer overheats. |
| Fan Motor Delay Stop Time: | 140 \pm 30 seconds. (at room temperature) |
| ALC: | Negative going, adjustable threshold -8V DC maximum output (typical). |
| Power Tubes Used: | Eimac 3-500Z, two pieces |
| Semiconductors: | Diodes, 18 pieces Zener diode, 1 piece |
| Power Requirements: | 120V, 28A; 240V, 14A; 50/60Hz; for maximum SSB input. |
| Cables Supplied: | Signal cable (coaxial) with UHF-type connector, 1.5m. Control cable, 1.5m. |
| Dimensions: | 390mm \times 190mm \times 407mm (15-3/8 \times 7-1/2 \times 16") |
| Weight: | Net 31 kg (68 lbs.) Shipping 38 kg (83 lbs.) |

The above specifications are subject to change without notice due to technical improvement.

SECTION 1. FEATURES

- 1. The TL-922A is a Class AB2, grounded grid linear amplifier developed by Trio-Kenwood through advanced high-power technology using two high-performance Eimac 3-500Z power tubes. It covers all bands 160 m through 15 m for SSB, CW and RTTY modes of operation.**
- 2. Unprecedented Reliability**

The TL-922A is designed to provide stable, high RF output power for extended periods of continuous use. Engineered with Trio-Kenwood's advanced circuit and mechanical technology, the TL-922A employs two rugged 3-500Z power tubes to their full advantage.
- 3. Low Intermodulation Distortion**

Intermodulation distortion (IMD) is minimized through the use of negative R.F. feedback.
- 4. Quick Turn-On**

Warm-up is not necessary. The 3-500Z tubes are fast heating.
- 5. Full Safety System**

To protect you against any possible high voltage electric shock, your TL-922A has a double safety system comprised of interlocking switches. One interrupts the high voltage primary circuit while the second directly grounds the secondary high voltage circuit. Also provided are bleeder resistors for discharging the high voltage capacitors and "DANGER" warnings at high voltage positions. Please observe all warnings, they are for your protection.
- 6. Newly-Developed Fan Motor Delay Stop Circuit**

To reduce power tube deterioration, your TL-922A has a newly-developed fan motor delay-stop circuit comprised of a thermal delay relay. The cooling fan will normally run for 140 seconds (Typ) after power is removed from the unit and will measurably extended tube life.
- 7. Mode Switch for Efficient Linear Operation**

MODE switching is provided to select between the SSB Mode for the maximum PEP output with good linearity, and the CW Mode for low power consumption and heat generation during extended periods of operation.
- 8. Linear Amplification Control Switch**

This switch is capable of setting your TL-922A in the straight-through state irrespective of the standby control on the exciter.
- 9. Variable Threshold Level (ALC Detector)**

The ALC circuit will accommodate exciters of 80 w to 120 w (nominal) by varying the ALC threshold level. This effectively prevents overdriving the final power tubes, limiting the Amplifier to its linear range and guaranteeing low distortion at maximum power.
- 10. Two Panel Meters**

In adjusting or monitoring your TL-922A, one meter always indicates the (Ip) plate current; while, with the other, you may read (Ig) grid current, (RF) relative output, or (HV) high voltage. This facilitates ease of operation of your TL-922A.
- 11. Rigid Mechanical Structure**

The die-cast side panels effectively support the weight of the amplifier against shocks and jarring during transportation. Recessed side panel handles are provided so the Amplifier can be easily carried.
- 12. Vernier Plate Tuning Dial**

The PLATE tune dial is equipped with a reduction gear that facilitates easy tuning, particularly for the higher bands. It also effectively prevents accidental miss-tuning during operation. Controls and panel arrangement, designed to human engineering standards, provide superior ease of operation.
- 13. Neat, Contemporary Appearance**

Mechanical arrangement and sophisticated design to match any Trio-Kenwood transceiver or transmitter. Your TL-922A can also be used as a high-quality, general purpose Amateur band linear amplifier with any exciter capable of 80W to 120W RF output.

SECTION 2. PREPARATION FOR USE

2.1 ACCESSORIES

Carefully unpack your TL-922A Linear Amplifier and check that it is supplied with the following accessories.

- | | |
|---|----------|
| 1. Instruction manual B50-2587-20 | 1 copy |
| 2. Coaxial cable, 1.5m, with UHF-type connectors X42-1100-00 | 1 piece |
| 3. Control cable W/8Pin Plug (For TS-520, TS-820 Series) X42-1110-10 | 1 piece |
| 4. Control cable W/7 Pin Plug (For TS-120, TS-130, TS-180, TS-430, TS-440, TS-530, TS-830, TS-930, TS-940 Series) X42-1110-11 | 1 piece |
| 5. Spare fuse, 15A F05-1533-05 | 2 pieces |
| 6. Extension foot J02-0049-14 | 2 pieces |
| 7. Screws, 4 x 12mm long N30-4012-46 | 2 pieces |
| 8. Plate cap F02-0407-04 | 2 pieces |
| 9. Parasitic suppressor coil, right hand L39-0401-05 | 1 piece |
| 10. Parasitic suppressor coil, left hand L39-0402-05 | 1 piece |
| 11. Screw, 3 x 6mm long N30-3006-46 | 4 pieces |
| 12. Plain washer N15-1030-46 | 4 pieces |
| 13. Spring washer N16-0030-46 | 4 pieces |

2.2 INSTALLATION OF POWER TUBES

To protect the power tubes in your TL-922A against vibration and shock during transport, they were packed separately from the amplifier. For insertion, follow the procedures below. Prepare the following mounting hardware and tools:

Mounting Hardware

- | | |
|---|--------------|
| Power tube, 3-500Z | 2 pieces |
| Plate cap | 2 pieces |
| Parasitic suppressor coil, right hand and left hand | 1 piece each |
| Screw, 3 x 6 mm long | 4 pieces |
| Plain washer | 4 pieces |
| Spring washer | 4 pieces |

Tools

- | | |
|----------------------------|---------|
| Phillips screwdriver | 1 piece |
| Small standard screwdriver | 1 piece |

NOTE: A parts tray to prevent loss of metric hardware is helpful.

WARNING: Before proceeding, make sure that:
The power cable is NOT plugged in the wall outlet. The METER switch is at the HV position and the multimeter reads OV.

Proceed as follows: (Refer to Fig. 2-1)

1. Remove the four 4 mm Phillips screws holding the upper case cover.
2. Remove the upper case cover.
3. Remove the four 3 mm self-tapping Phillips screws and four flat head self-tapping Phillips screws holding the inside shield on the power tube enclosure.

4. Remove the shield plate.
5. Take the tubes out of their case (Refer to Fig. 2-2). In handling, be sure to hold them by the glass envelope, not the plate cap.
6. Carefully index the pins of each tube into its socket and insert gently without excessive force.

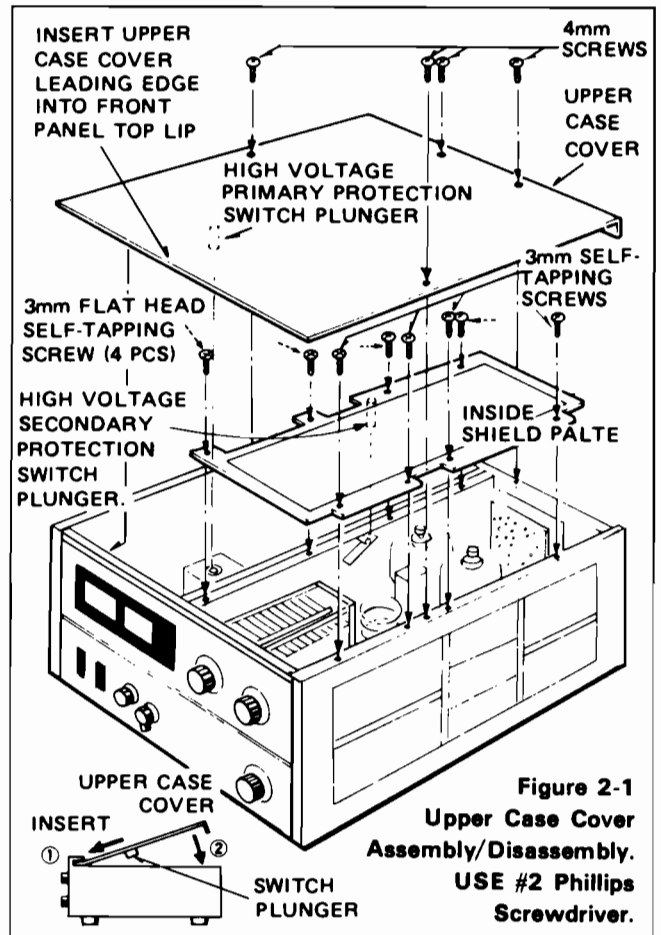

Figure 2-1
Upper Case Cover
Assembly/Disassembly.
USE #2 Phillips
Screwdriver.

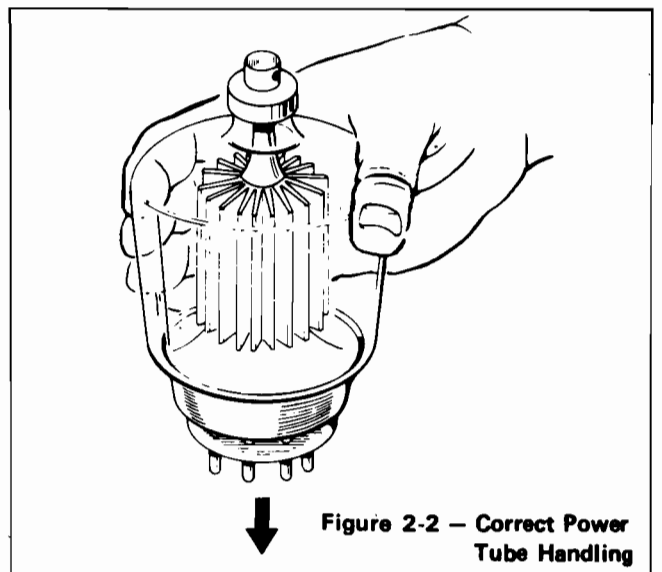

Figure 2-2 — Correct Power
Tube Handling

CAUTION

Particular care should be taken not to strike and break the glass tubes during installation. Tube breakage due to negligence is not warranted

7. (Refer to Fig. 2-3) Temporarily fix each parasitic suppressor coil on the plate cap with the letter "R" or "L" facing up. At this time, do not tighten the 4 mm screw and spring washer, but snug them so the coil may be adjusted.
8. Mount the plate cap with parasitic suppressor coil on each tube observing the right hand and left hand coil designations. If the screw holes do not align, shape the coil by slight bending or extending by hand for precise installation, keeping the coil below the level of the plate cap.

CAUTION: Particular care should be exercised in not applying excessive force to the tubes.

9. Carefully tighten the screws at each end of the coil while holding the plate cap by hand.
10. Tighten the plate cap screw using the small standard screwdriver.
11. Check to assure correct installation by reference to Fig. 3-3.

NOTE:

- 1: Before installation, check each parasitic suppressor coil for good alignment to prevent the application of excessive force to the tubes.
- 2: Letters "R" and "L" on the coils should face up.
- 3: Temporarily install each coil on their plate caps before final tightening. Use # Philips screwdriver.

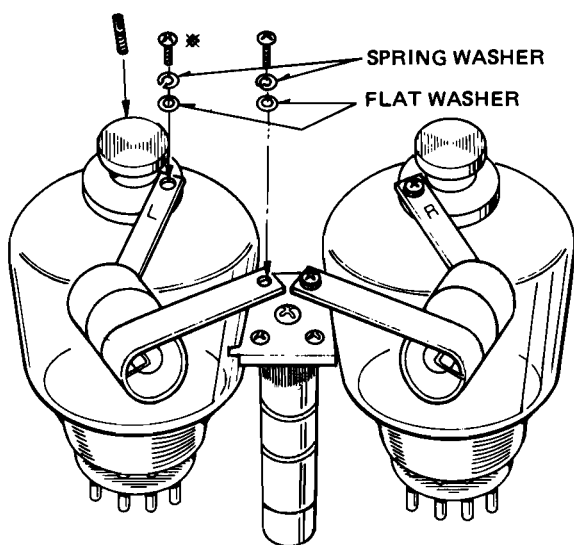

Figure 2-3 — Parasitic Suppressor Coil Mounting

Tube Installation Checkout

1. To avoid damage necessitating tube replacement, please check:
 - a. Power tubes are free from scratches or other physical defects.
 - b. Tubes are fully inserted into their sockets.
 - c. Plate cap screws tightened securely.
 - d. Screws at both ends of the parasitic suppressor coils are tightened securely.
 - e. Washers, screws, drivers and any other unnecessary material is not left inside the unit.
2. Refer to Fig. 2-1. The inside shield plate includes the high voltage secondary protection switch plunger (a bakelite bar.) Position the plate so that the plunger will securely engage the spring plate for ungrounding the plate high voltage.
3. Install the upper case cover with its leading edge inserted (approximately 1 mm) into the front panel lip. This cover has the high voltage primary protective switch plunger. Position the cover so the plunger will engage the microswitch.

2.3 GENERAL TIPS ON INSTALLATION

Install in a dry, well-ventilated area, shaded from direct Sun-light. Your TL-922A must have a minimum clearance of 15 cm to the rear to allow hot air at 50 to 70°C to exhaust.

Choose an operating position capable of safely supporting the weight of the TL-922A (31 kg), plus all the other station equipment.

Level your TL-922A in operation. The heated electrodes in each power tube will be distorted by gravity resulting in shortened service life, if slanted beyond 10°.

2.4 AC POWER SOURCE

Use an AC power line having sufficient current capacity or the performance of your TL-922A will be adversely affected by inadequate line regulation. In the worst case, do not deviate more than ±10% from the rated input voltage for which your Amplifier has been set.

2.5 LINE VOLTAGE CHANGE

WARNING

DISCONNECT THE AC INPUT POWER CABLE FROM THE TL-922A BEFORE PROCEEDING.

The input voltage can be changed to either 240V or 120V as required, by changing the power transformer input links located in the duct on the rear panel.

NOTE: The TL-922A was factory set in the 240V position.

To change link positions, remove the access cover by the two black snap fasteners. Loosen the screws holding the shorting bars, a few turns only. (Do not loosen excessively as they could drop into the Amplifier.) Draw each shorting bar upward for removal. Replace the shorting bars for the operating voltage desired as illustrated in Fig. 2-4. Tighten firmly. Also, be sure to tighten the screws from which the shorting bars were removed.

NOTE: Fuses need not be changed in current rating when the input voltage is changed.

CAUTION: Excess force may break the terminal strip.

2.6 POWER CABLE

The power cable supplied with your TL-922A has no plug at its end. Connect a plug mating with the wall outlet. The blue and brown leads are power, the green lead ground as illustrated in Figure 2-5.

2.7 EXCITER

An HF Amateur band SSB or CW transmitter or transceiver having an RF output impedance of 50Ω and output power of 80W to 120W is sufficient to drive the TL-922A. Exciter output exceeding 120W will cause overdrive, resulting in shortened power tube life and distorted output. To limit the power level above 120W, use an exciter having an external ALC input terminal.

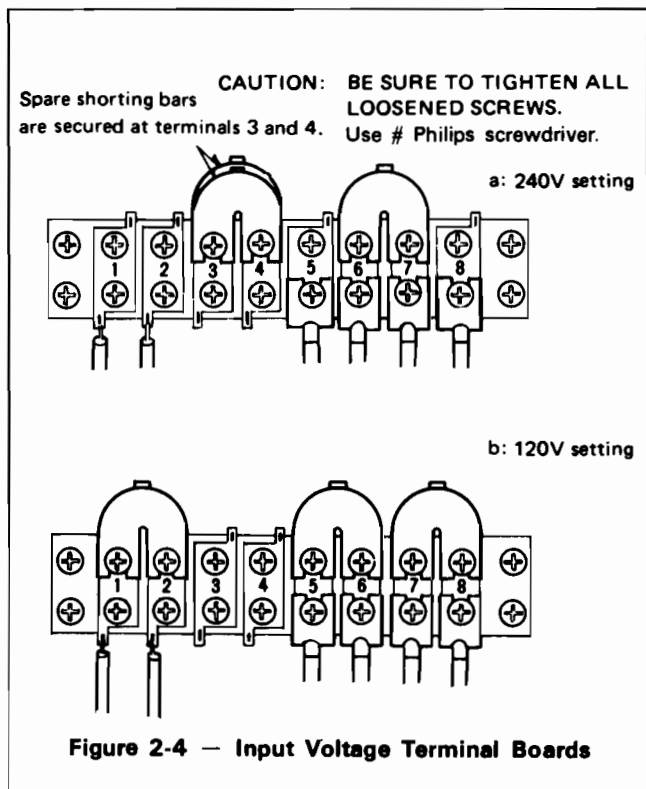

Trio-Kenwood's transceivers Series TS-930, TS-940, TS-830, TS-820, TS-530, TS-520, TS-430, TS-440S, TS-180, TS-130, TS-120 and TS-900 and transmitters Series TX/T-599 are all suitable exciters and will match the TL-922A in design as well as appearance.

NOTE: When the TS-440S is used, the modification is necessary.

Refer to TS-440S instruction manual.

2.8 ANTENNA

Your TL-922A requires an antenna having a 50 to 75Ω impedance and providing it is:

- (1) **Rated for 2 kW P.E.P. input power**
 - (2) **and, exhibits a low standing-wave ratio (SWR)**
- Desired SWR is 1.5 to 1, or less. A higher SWR, 2 or 3 to 1, may cause difficult matching with your TL-922A. Excessive SWR could melt the coaxial cable and antenna. To protect your TL-922A against adverse SWR effects, use an antenna tuner. Note that feeder radiation due to mismatching will cause TVI, BCI, or similar RFI.

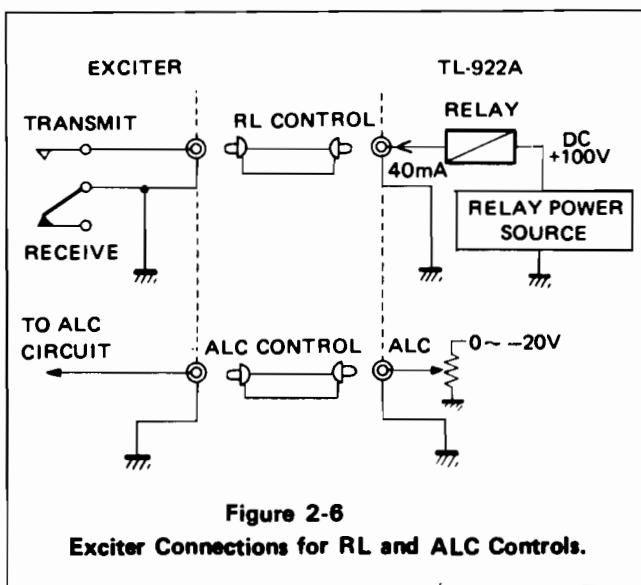
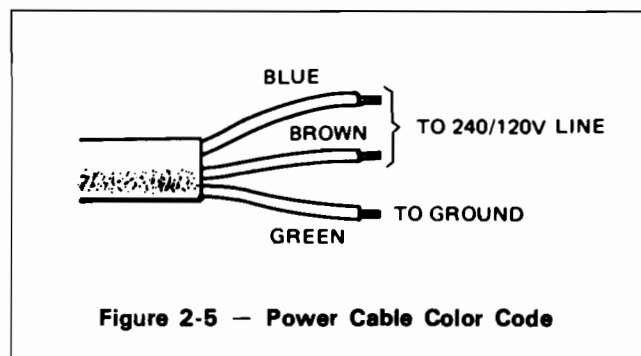

2.9 INTERCONNECTION

2.9.1 GROUNDING

Connect the GND posts of the TL-922A and exciter to prevent possible electric shock and RFI. The wire used should be as thick and short as possible and run to a good earth ground.

2.9.2 CABLE CONNECTION

Interconnect your TL-922A and exciter with the supplied cables as illustrated in Figure 2-7.

NOTE: If you use an exciter of another brand, replace the supplied connector with one appropriate to your exciter. The exciter used must accept the negative-going ALC voltage from the TL-922A.

(The ALC output at no signal input is normally positive when not connected to the exciter.)

The RL, or standby control, in the exciter must be switched to ground in transmit mode, as illustrated in Figure 2-6.

NOTE: Use RG-8/U, RG-11/U or heavier as antenna cable.

NOTE: If an SWR meter is connected between the TL-922A and the exciter, total coaxial cable length must not exceed 1.7 m.

SECTION 3. CONTROLS AND THEIR FUNCTIONS

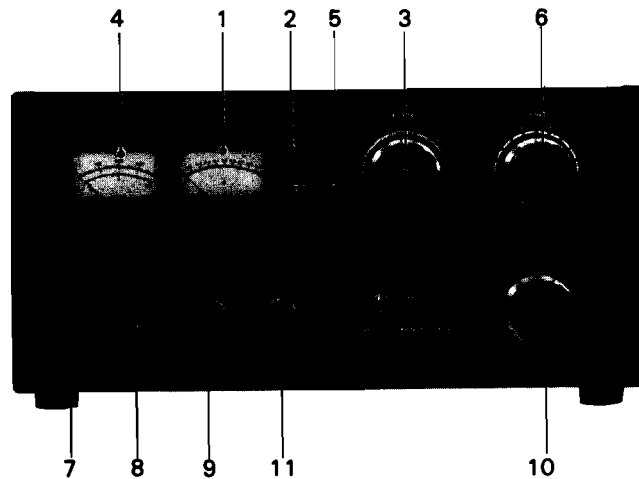

Figure 3-1 Front Panel View

3.1 FRONT PANEL

1. **IP Meter**
The IP meter reads the plate current flowing through the power tubes.
2. **ON AIR Indicator**
The ON AIR indicator lights up in the on-the-air, or transmit MODE.
3. **PLATE Tuning Control**
This control permits you to tune the plate circuit to the desired transmit frequency, and is equipped with a reduction gear for easy tuning.
4. **Multimeter**
The Multimeter can read the I_g (grid current), RF (relative power output), or HV (plate voltage) as selected by the METER switch.
5. **STBY Indicator**
With the unit turned on, shows unkeyed or receive state.
6. **LOAD Control**
Impedance matches the pi network to the antenna.
7. **POWER Switch**
A double pole switch completely disconnects the AC input from the transformers.
8. **MODE Switch**
Set for SSB or CW. For RTTY operation, set the switch to the CW position.
9. **METER Switch**
Selects I_g (grid current), RF (relative power output), or HV (plate voltage).
10. **BAND Selector**
Set for the Amateur band in which operation is desired.
11. **LINEAR Switch**
In the STBY position, the exciter runs straight through. In the OPERATE position, the Amplifier automatically keys with the exciter.

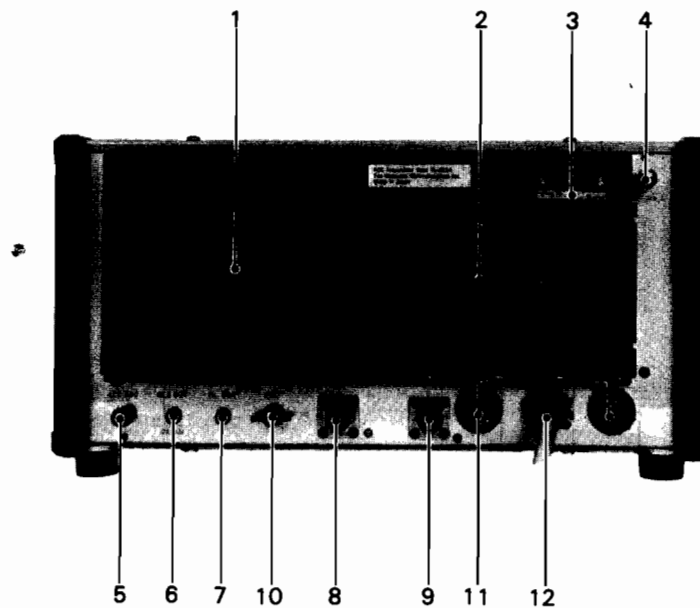

Figure 3-2 Rear Panel View

3.2 REAR PANEL

1. **Cooling Fan**
The Cooling Fan cools the power tubes and effectively keeps the inside temperature from increasing. **Be careful of hot air (50° to 70°C) at the exhaust port.**
2. **Line Voltage Change Terminals**
These terminals are located behind the rear cover, which is removed by pulling the two snap fasteners. For input voltage change, please refer to Section 2.5.
3. **Serial No. Plate**
This plate is stamped with the Serial Number of your TL-922A.
4. **RF METER Control**
This control is used to calibrate the RF output reading. For calibration, see Section 4.6.
5. **ALC ADJ Control**
This control is used to adjust the ALC voltage. For adjustment, see Section 4.5.
6. **ALC OUT Jack**
This jack feeds the ALC voltage out.
7. **RL CONT Jack**
This jack inputs the transmit-receive relay switching ground from the exciter.
8. **RF INPUT Connector**
This UHF-type connector inputs the RF signal fed from the exciter. Use the supplied cable.
9. **RF OUTPUT Connector**
This UHF-type connector feeds the RF output to the antenna.
10. **GND Post**
Use this post to ground the TL-922A to your exciter and station ground.
11. **FUSE Holders (2)**
Each contains a 15 A fuse. If either or both fuses are blown, determine the cause before replacement.
12. **POWER Cable**
AC power is supplied to the amplifier by a three-wire cable. (See section 2.6)

SECTION 4. OPERATION

4.1 PRECHECKS

If you are a newcomer to this type of equipment, or if you have replaced a power tube, you should first assure yourself of the following **before connection of power and turn on:**

- a. **Power tubes are installed correctly.**
Verify tube installation checkout with Section 2.2.
- b. **The upper case cover and inside shield plate are correctly installed per Section 2.2.**
The upper case cover controls the high voltage primary protection circuit. This circuit also controls the fan motor power. The inside shield plate controls the high voltage protection circuit, grounding the HV supply, which will immediately blow the power fuses if incorrectly installed. Particular care should be exercised when installing the inside shield plate. In addition, the upper case cover and inside shield plate are needed for heat-sinking the interior of your TL-922A. For installation of these plates, please refer to Section 2.2, "How To Install Power Tubes."
- c. **Line voltage change terminals are properly bridged for your local Line voltage.**
Refer to Section 2.5 "Line Voltage Change."
- d. Make certain that the exciter, antenna and ground wires are connected properly. Verify that the POWER switch on your TL-922A is in the OFF position **BEFORE CONNECTING** the AC power cable.
- e. Set the front panel controls of your TL-922A as follows:

TABLE 4-1 — Front Panel Controls Initial Set-Up

| Control | Position To: |
|---------|-----------------------------|
| LINEAR | STBY |
| METER | HV |
| MODE | CW |
| PLATE | Center of band used |
| LOAD | Fully counter-clockwise "O" |
| BAND | Exciter frequency |

CAUTION: Be sure to set the BAND switch to the same band as that of the exciter before operation is attempted.

Now you may turn the POWER switch "ON". Make certain that the fan motor is revolving. The Multimeter will read approximately 2 kV on the HV scale. If you turn the MODE switch to the SSB position the meter will read approximately 3 kV.

Turn the LINEAR switch to the OPERATE position. The exciter now controls the TL-922A for automatic transmit/receive operation. In the CW transmit mode, Ip (plate current) in the no signal state should be approximately 100 mA; in the SSB transmit mode, no signal state should be approximately 200 mA.

4.2 CW OPERATION

CAUTIONS: 1. Tune-up should be accomplished quickly or power tube life will be shortened. Maximum key-down: 10 minutes.
2. Full break-in operation is not possible. If the exciter operates full break-in operation, TL-922A may be damaged.

1. Adjust the exciter for maximum output.
2. Set the amplifier Mode switch to the CW position, multimeter to RF.
3. Adjust the carrier control on the exciter for a 50 W level.
4. Set the LINEAR switch on your TL-922A to the OPERATE position.
5. Increase the carrier control on the exciter for sufficient drive to adjust the tuning.
6. Quickly switch the amplifier to Ip and dip the plate.
7. Switch the amplifier to RF and adjust loading for maximum output.
8. Increase exciter output to maximum power (about 100W). Repeat steps 6 and 7 several times for the highest RF output. If the Ip exceeds 650 mA, reduce the RF input from the exciter by turning the ALC ADJ control on the rear panel. Refer to Section 4.5 "Setting the SLC".
9. Make certain that the Ig (grid current) is below 200 mA. If not, adjust the ALC ADJ control to reduce the RF input level.

CAUTION: Never change the BAND switch while transmitting.

**TABLE 4-2 —Tune and load initial setting
100W input 50Ω output loading.**

| Band | Freq. (MHz) | Initial load setting | |
|------|-------------|----------------------|-----|
| | | CW | SSB |
| 160 | 1.8 | 4 | 2 |
| | 2.0 | 5.5 | 3.5 |
| 80 | 3.5 | 3 | 2.5 |
| | 4.0 | 4 | 3 |
| 40 | 7.0 | 3 | 2 |
| | 7.3 | 3.5 | 2 |
| 20 | 14.0 | 4.5 | 4 |
| | 14.35 | 4 | 3.5 |
| 15 | 21.0 | 5 | 4.5 |
| | 21.45 | 5 | 4.5 |

4.3 SSB OPERATION

Tune up as in CW operation. Reduce the exciter carrier control to minimum and change the linear mode to SSB. Increase the exciter carrier control and tune for maximum output. When tune up is complete, reduce carrier level to minimum.

CAUTION: DO NOT key the linear in SSB mode with full CW power. ALWAYS start and finish this procedure by reducing exciter carrier level to minimum.

DO NOT, under any circumstance OPERATE your exciter in the CW mode while the linear is in the SSB mode.

Failure to heed this warning may cause immediate, extensive damage to the amplifier, repair of which will not be covered by your warranty.

REPEAT: DO NOT OPERATE CW IN THE SSB MODE!

To improve linearity in the SSB mode, adjust the LOAD control 0.5 to 1.0 division clockwise from the maximum RF output position and readjust the PLATE tuning control for maximum reading on the RF scale. This adjustment should be made only once (not repeated) and will minimize possible distortion at peak I_p (plate current) allowing your TL-922A to run at optimum linearity. Note that the I_p (plate current) should not exceed 400 mA for voice peaks. Even this low degree of plate current is enough to fully drive the amplifier. Do not drive the power tubes excessively, turn off the ALC or otherwise run the Amplifier to distortion. This will also generate spurious emissions causing interference with local stations. Greatest operating efficiency, cleanest signal and extended tube life can be achieved by conservative operation.

4.4 RTTY OPERATION

CAUTION: Maximum key down, 10 minutes.

To use a radioteletypewriter (RTTY) with your TL-922A, follow CW tune-up procedures outlined in Section 4.2.

4.5 SETTING THE ALC ADJ CONTROL

Some exciters may cause the I_p (plate current) in your TL-922A to exceed 650 mA in the CW mode or the I_g (grid current) to exceed 200 mA. If this occurs, remove the cap nut and adjust the ALC level control on the rear panel to bring current within specified limits.

If, after following the tune-up procedures outlined in Section 4.1, I_p and I_g cannot be reduced to their specified level, proceed as follows:

1. Set the carrier level for 600 to 650 mA maximum I_p (plate current) and 200 mA or less I_g (grid current). Adjust plate, and load controls for maximum RF output.
2. Increase the carrier level until I_p (plate current) and I_g (grid current) slightly exceed the specified values (no more than 750 mA maximum).
3. Set the ALC ADJ control until the I_p (plate current) is 650 mA or the I_g (grid current) is 200 mA. If neither reading is affected by this adjustment, re-setting is unnecessary. High current indicates over-drive, which results in excessive distortion, spurious emissions and shortened tube life.

4.6 ADJUSTING THE RF OUTPUT METER

The swing of the RF output reading varies with the impedance of the antenna. To adjust, remove the cap nut and set the RF METER control on the rear panel to register a 7 division swing when the RF output is maximum on any selected band.

4.7 HIGH VOLTAGE TRANSFORMER PROTECTION

The high voltage transformer in your TL-922A has a thermal protection circuit which operates only if the inside temperature of the transformer rises over 145°C due to either a full power, continuous transmission longer than 30 minutes, or continuous operation in a high ambient temperature environment. The protection circuit then locks the TL-922A in the STBY state. The standby relay in your TL-922A cannot be activated regardless of any switch setting. If protection has occurred, it has likely been caused by a continuous run exceeding the rated capacity of the amplifier. **Leave the POWER switch "ON" to allow forced air cooling.** While cooling, the exciter will operate straight through. Protection lock will be released in approximately 15 minutes. Resume Amplifier operation with its power lowered appropriately.

4.8 CARRYING YOUR TL-922A

Your TL-922A weighs 31 kg. (68 lbs.). To carry, use the handles on the side escutcheons. Do not slide or drop it, as the plastic legs could be damaged. Do not apply excess stress to the case. When being transported, repack the unit in its original shipping container as it was delivered upon purchase. Whenever your TL-922A is likely to be subjected to vibrations during transport also remove the power tubes and repack in their original boxes. See Fig. 7-1 "Packing for Shipment."

SECTION 5. CIRCUIT DESCRIPTION

5.1

The linear power amplifier in your TL-922A is a grounded grid class AB₂ amplifier consisting of two Eimac Hi-mu, zero bias triodes, 3-500Z, providing the following features:

1. Low IMD (intermodulation distortion) through negative RF feedback.
2. The grounded grid circuit does not require neutralization.
3. Due to its low input impedance, no cathode-swamping resistors are required.
4. High stability at any frequency.
5. Excitation energy is added to the RF output and is not lost.

Figure 5-1 shows a circuit diagram of the Linear Power Amplifier. The input matching circuit, comprised of L9 through L14, Cin-1, and Cin-2, matches the exciter impedance with the input circuit impedance to efficiently feed exciter energy into the power tubes. The tubes are heated by the center tapped filament transformer T2 requiring current only half the usual, preventing voltage drop due to wire resistance.

The choke coils L20 and L3 high frequency isolate the filaments from the filament transformer. The bias voltage, which determines the operating point of the tubes, is produced across zener diode D2. This diode carries the full current of the tubes excepting filaments. The grids are DC grounded through L7 and L8 and high-frequency grounded by C28 through C33.

The pi network, comprised of VC1, L4, L5 and VC2, matches the plate impedance to the antenna. The tubes are cut off to stand by through a positive voltage of approximately 100 V applied to the filament circuit.

5.2 POWER SUPPLY

The plate high voltage is supplied from a voltage doubling rectifier comprised of a large-capacity, small-sized transformer T1, fourteen high-voltage rectifier diodes rated 800 PIV and eight 200 μ F electrolytic capacitors rated 550 V surge. To improve reliability, the diodes are P.C.B. mounted and the electrolytic capacitors are held by plastic spacers. Filament voltage, relay energizing voltage (in common with the tube cut-off bias voltage), and pilot lamp voltage are supplied from transformer T2. Each primary of the power transformers T 1 and T 2 has two windings, each of which is fused. Note that fuses are not changed when the input line voltage has been changed (see Fig. 5-2).

5.3 FAN MOTOR DELAY STOP CIRCUIT

The cooling fan is held on for approximately 2 minutes to cool the power tubes after the POWER switch is turned off. This is accomplished by the fan motor delay stop circuit comprised of a bimetal thermal relay.

Figure 5-3 is a schematic diagram illustrating the circuit. When the POWER switch is at OFF, both the relay RL1 and the thermal relay DL1 are not activated and the fan is off.

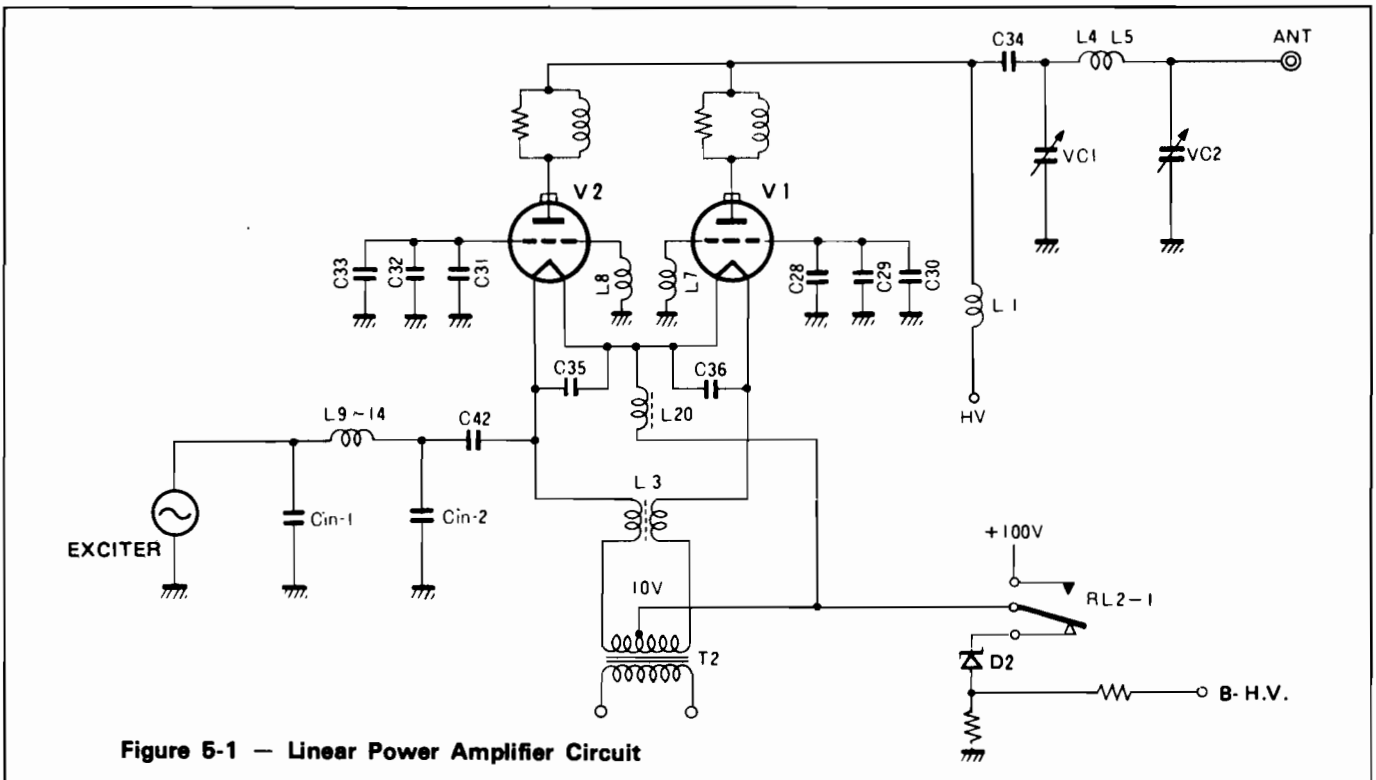

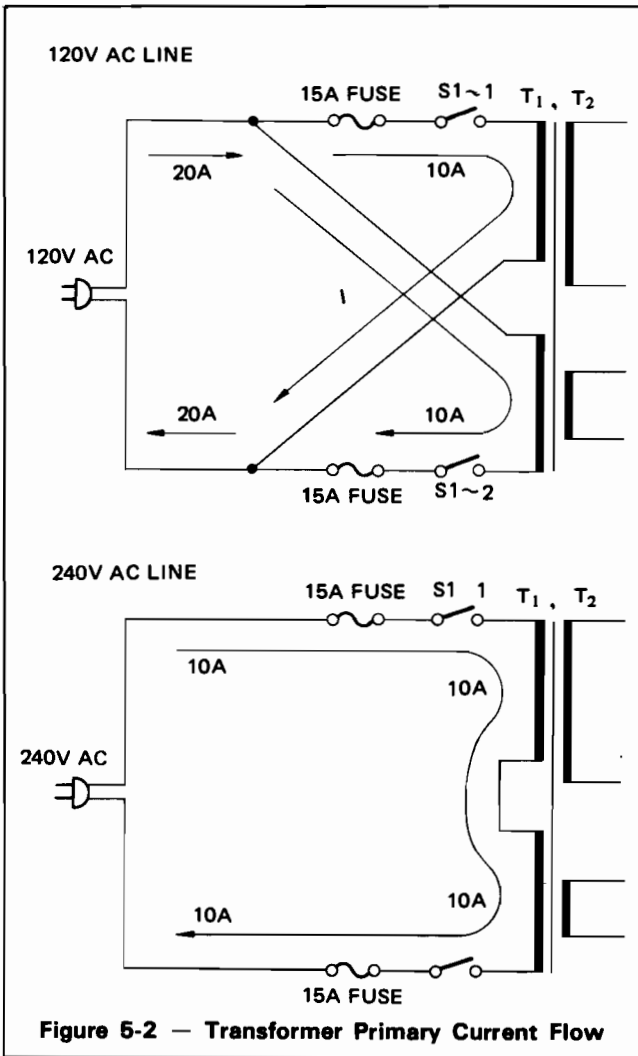

Figure 5-2 — Transformer Primary Current Flow

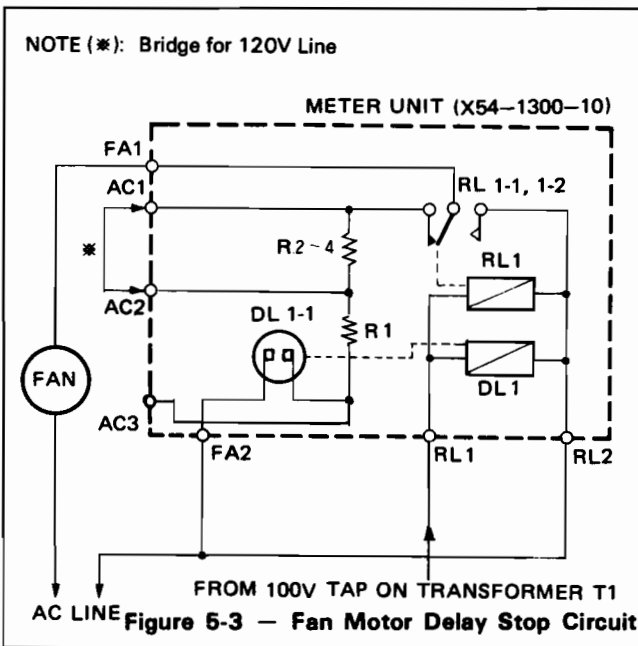

Figure 5-3 — Fan Motor Delay Stop Circuit

By turning the POWER switch to ON, RL1 is activated starting the fan. At the same time, voltage is applied to DL1 generating heat, which makes the contact DL1-1 close in approximately 60 seconds. By turning the POWER switch to OFF, RL1 is de-energized, returning contacts RL1-1 and RL1-2 to their home positions. But, the fan continues operating as the thermal relay contact DL1-1 is still closed. DL1-1 opens after approximately 140 seconds thereby stopping the fan.

5.4 METER DRIVE CIRCUIT

The power tube I_p (plate current) and I_g (grid current) can be read on their individual meters. Figure 5-4 is the meter drive circuit. I_p (plate current) is measured through shunt resistor $R6$ (1Ω), and deflects the I_p meter through $R7$ ($1.5k\Omega$) which adjusts meter sensitivity. Similarly, I_g (grid current) is measured on the Multimeter. In addition to the I_g , the Multimeter can selectively read relative RF output (which is a rectified RF signal), and HV (plate voltage). Precise plate voltage reading is obtained through three serial voltage dividing resistors of 5% tolerance.

5.5 SPARK SUPPRESSOR

Your TL-922A contains an oversized relay for conservative operation and its action is slower than smaller relays. The TL-922A is momentarily run leaving the antenna circuit open in such operations as VOX. This leads to high Q at the output circuit which would cause excessive voltage at the plate tuning capacitor. This could arc the capacitor. To prevent this, your TL-922A has a discharge gap device at the antenna relay terminals to dissipate any unusually high voltage. During relay changeover, you might sometimes hear arcing from the discharge gap. This is not a failure and should be considered normal.

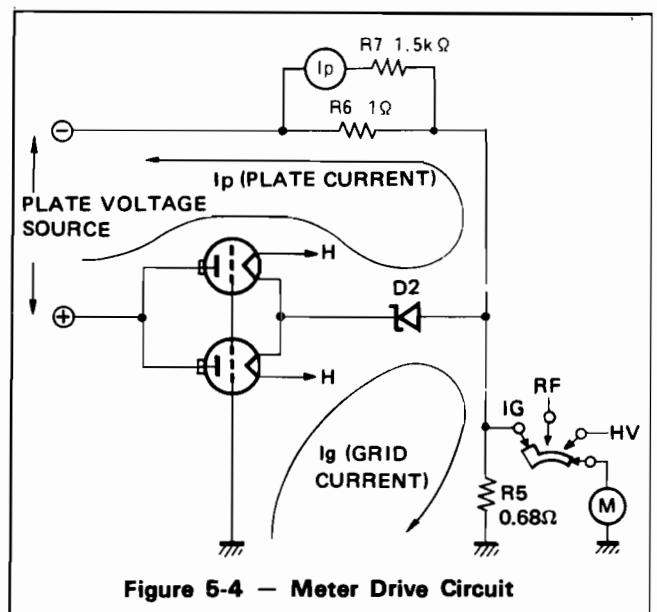

Figure 5-4 — Meter Drive Circuit

SECTION 6. MAINTENANCE

WARNING

YOUR TL-922A USES VERY HIGH VOLTAGE. **DISCONNECT ALL POWER FROM THE TL-922A BEFORE REMOVING OR REPLACING ANY PARTS, PARTICULARLY IN REMOVING THE UPPER AND LOWER COVERS FOR MAINTENANCE. ALSO MAKE CERTAIN THAT THE HV METER READS "0"!**

6.1 INTERNAL CLEANING

The cooling fan in your TL-922A pulls air in through the bottom and side walls. Every three months, vacuum clean the bottom vents, side escutcheon vents, tube glass and sockets and all areas in which dust collects. Include the high voltage diodes, the electrolytic capacitors, the vanes of the plate and load tuning variable capacitors and the fan. This is necessary to prevent arcing and overheating.

6.2 REPLACING THE POWER FUSES

Power fuses are located at the rear of the TL-922A. In the

event of blown fuses, first determine the cause. For replacement, use only 15 A fuses, either in 120V or 240V line operation.

WARNING

Be sure to disconnect the power cable before replacing fuses.

6.3 REPLACING THE POWER TUBES

Refer to Section 2.2 "Installation of Power Tubes".

6.4 INPUT MATCHING CIRCUIT

The input matching circuit is preset at the factory for broad band characteristics and needs no adjustment. There are dangerous high RF and DC voltages in the circuit. For readjustment, contact your nearest Trio-Kenwood authorized service facility.

SECTION 7. TROUBLESHOOTING HINTS

| TROUBLE | COMMON CAUSE | REMEDY |
|---|--|---|
| <p>1. No power output</p> <p>1) Relay will not activate.</p> <p>2) Relay is activated.</p> <p>a. Exciter RF meter swings off scale.</p> <p>b. HV meter will not swing, no Ip (plate current), cooling fan inoperative.</p> <p>c. Ip, RF meter swings off scale.</p> <p>d. Ip will not change.</p> | <p>a. Control cable disconnected.</p> <p>b. Power supply protector in lock due to temperature rise from extended transmission.</p> <p>c. LINEAR switch at STBY</p> <p>d. ALC and RL plugs reversed.</p> <p>Defective coaxial cable connection.</p> <p>Interlock switch not depressed due to faulty upper case cover installation.</p> <p>Antenna coaxial cable disconnected. RF INPUT and RF OUTPUT coaxial connectors reversed.</p> | <p>Secure control cable.</p> <p>Allow standby for approximately 15 minutes with power switch on for forced air cooling.</p> <p>Refer to Section 4.7.</p> <p>Turn switch to OPERATE.</p> <p>Correct reversed cables.</p> <p>Correct connection.</p> <p>Correct upper case cover installation. Refer to Section 2.2.3.</p> <p>Correct connection.</p> <p>Correct reversed cables.</p> |
| <p>2. Output power too low.</p> <p>1) Ip (plate current) below 400mA.</p> <p>2) Hv (plate voltage) in max. drive state below 1.5kV for CW and below 2kV for SSB.</p> | <p>a. Low exciter output</p> <p>b. Improper setting ALC ADJ control</p> <p>c. Different positions of BAND switches between exciter and TL-922A.</p> <p>Low line voltage.</p> | <p>Readjust exciter</p> <p>Readjust control. Refer to Section 4.5. Set both BAND switches to same position.</p> <p>Improve line regulation (refer to Section 2.4).</p> |
| <p>3. RF meter swing too hi or low.</p> | <p>Improper RF control setting.</p> | <p>Adjust RF control until RF meter reads Approximately 7 on scale. Refer to Section 4.6.</p> |
| <p>4. Fuse blows when POWER switch is turned "ON".</p> | <p>Inside shield plate incorrectly installed causing interlock switch to short high voltage line to ground.</p> | <p>Reinstall inside shield plate and replace fuse.</p> <p>Refer to Section 2.2.2.</p> |
| <p>5. Upper case over high voltage transformer too hot.</p> | <p>Line voltage change terminal cover on rear removed or ajar.</p> | <p>Replace cover securely.</p> |
| <p>6. Linear amplifier does not key.</p> | <p>1. Internal connector was not moved.</p> <p>2. REMOTE connector is miswired, or has a poor contact.</p> | <p>Refer to the TS-440S instruction manual.</p> |

PACKING FOR SHIPMENT

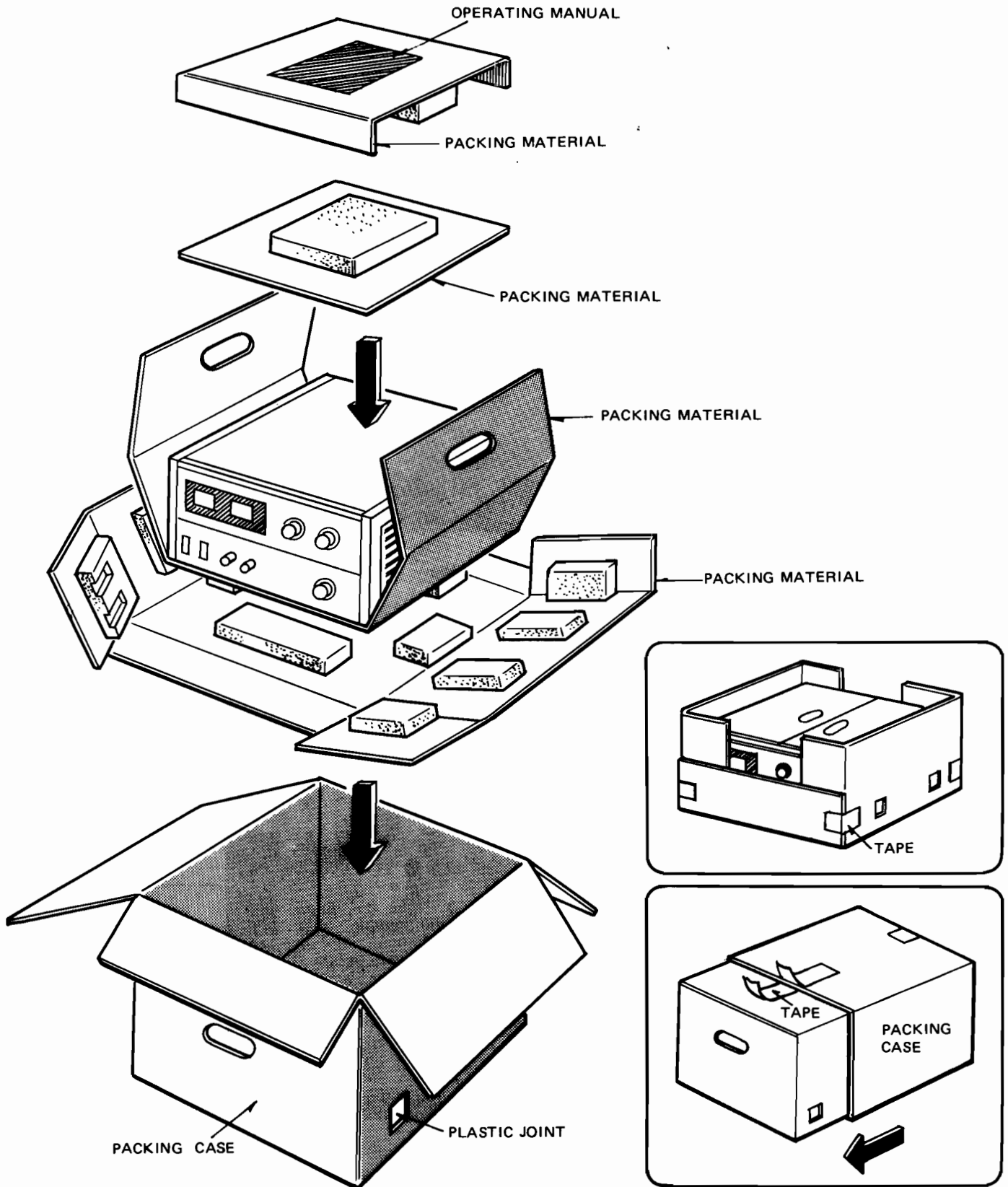

Figure 7-1 — Packing for Shipment

INTERNAL PARTS LOCATIONS

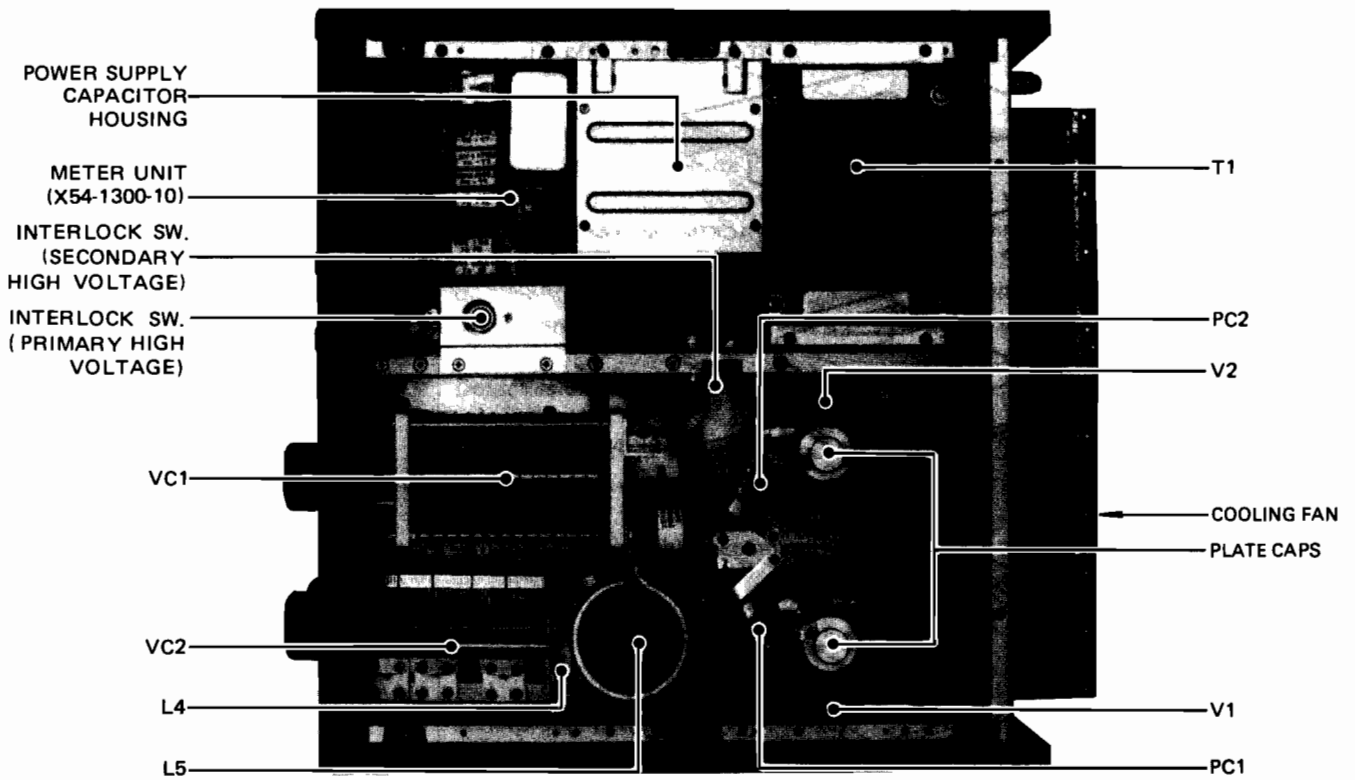

Figure 7-2 — Top View

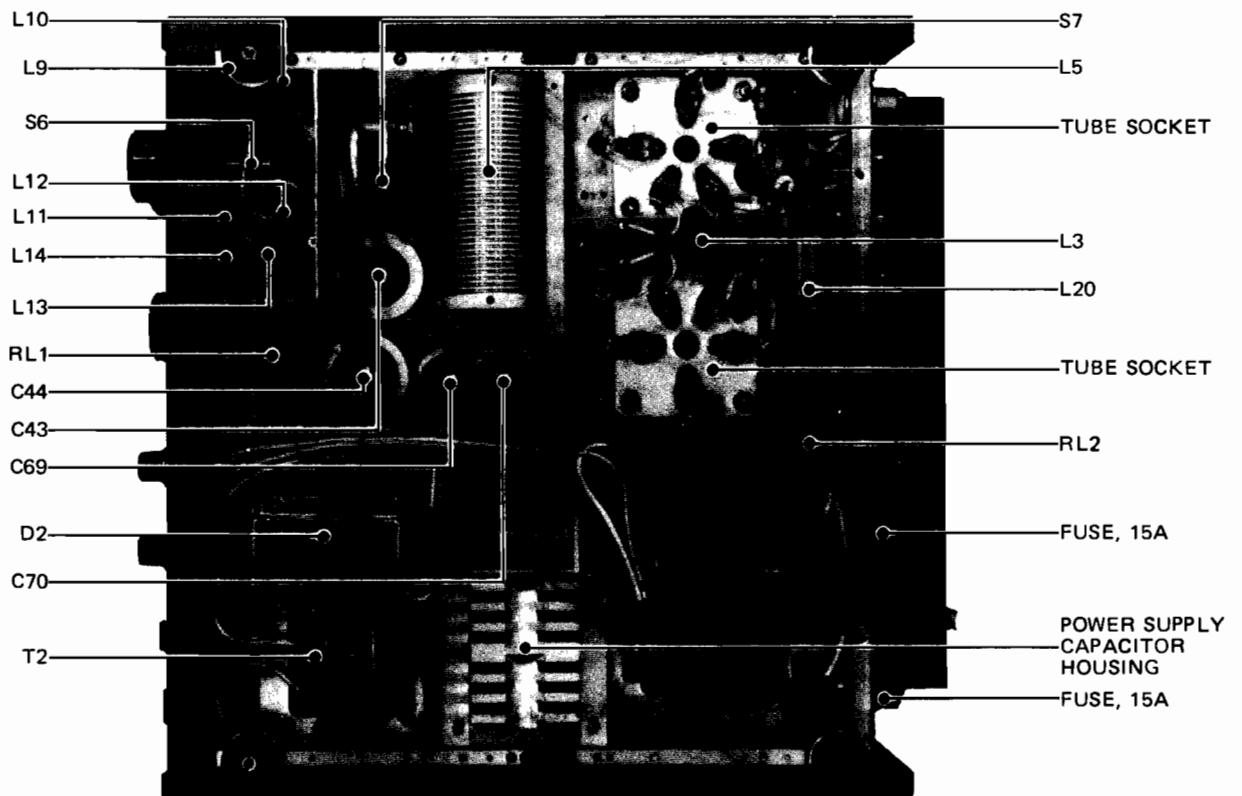

Figure 7-3 — Botoom View

SCHEMATIC DIAGRAM

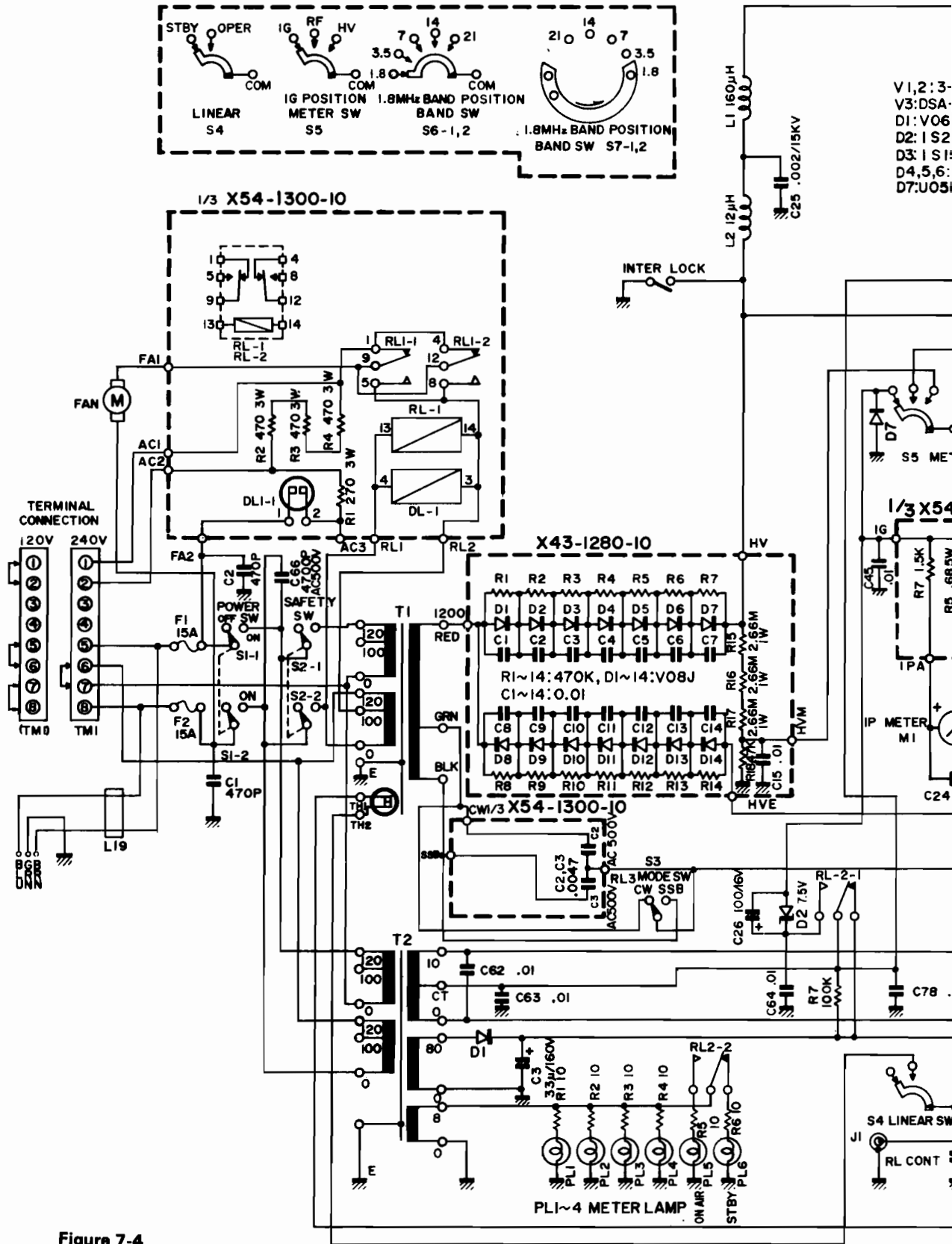
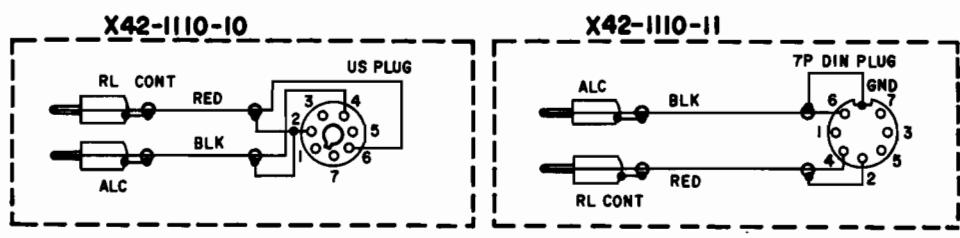
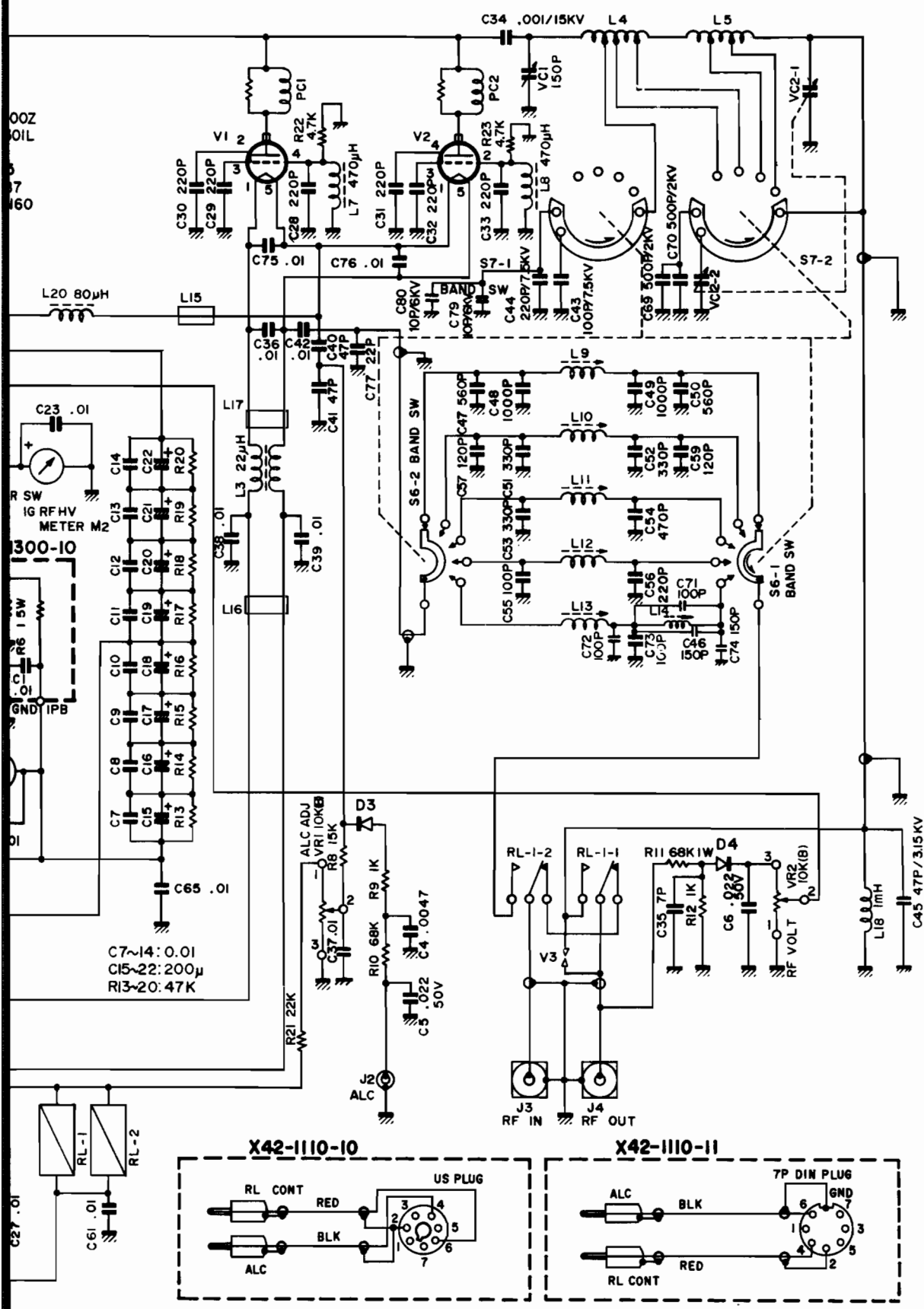

Figure 7-4



TL-922A(K)

Free Manuals Download Website

<http://myh66.com>

<http://usermanuals.us>

<http://www.somanuals.com>

<http://www.4manuals.cc>

<http://www.manual-lib.com>

<http://www.404manual.com>

<http://www.luxmanual.com>

<http://aubethermostatmanual.com>

Golf course search by state

<http://golfingnear.com>

Email search by domain

<http://emailbydomain.com>

Auto manuals search

<http://auto.somanuals.com>

TV manuals search

<http://tv.somanuals.com>