



User Guide

Lenovo B490, B590, B4301, B4302, B4303, B4305, B4306, B4307, B4308, B4309, B4310, B4311, B4312, B4315, B4316, B4317, B4318, B4319, B4320, B4321, B4322, B4323, B4325, B4326, B4327, B4328, B4329, B4330, B4331, B4332, B4333, B4335, B4336, B4337, B4338, B4339, B4360, B4361, B4362, B4363, B4365, B4366, B4367, B4368, B4369, B4370, B4371, B4372, B4375, B4376, B4377, and B4378

Before using this information and the product it supports, be sure to read and understand the following:

- *Safety, Warranty, and Setup Guide*
- *Regulatory Notice*
- “Important safety information” on page iv
- Appendix D “Notices” on page 65

The *Safety, Warranty, and Setup Guide* and the *Regulatory Notice* have been uploaded to the Web site. To refer to them, go to <http://www.lenovo.com/UserManuals>.

Second Edition (December 2012)

© Copyright Lenovo 2012.

LIMITED AND RESTRICTED RIGHTS NOTICE: If data or software is delivered pursuant a General Services Administration “GSA” contract, use, reproduction, or disclosure is subject to restrictions set forth in Contract No. GS-35F-05925.

Contents

Read this first	iii	Hardware connection	22
Important safety information	iv	Software configuration	23
Conditions that require immediate action	iv		
Safety guidelines	v		
Chapter 1. Getting to know your computer	1	Chapter 4. You and your computer	25
Top view	1	Accessibility and comfort	25
Left-side view	2	Ergonomic information	25
Right-side view	3		
Front view	4	Chapter 5. Security	27
Bottom view	5	Attaching a mechanical lock	27
Status indicators	5	Using passwords	27
Features	7		
Specifications	8	Chapter 6. Recovery overview	29
		Using the OneKey Recovery Pro program on the Windows 7 operating system	29
Chapter 2. Using your computer	9	Solving recovery problems on the Windows 7 operating system	29
Frequently asked questions	9	Using the Windows recovery program on the Windows 8 operating system	30
Tips on using your computer	10		
Reading the manuals	10	Chapter 7. Replacing devices	33
Connecting to power	10	Static electricity prevention	33
Turning on the computer	10	Replacing the battery	33
Configuring the operating system	10	Replacing the backup battery	34
Putting the computer into sleep mode or shutting it down	11	Replacing the hard disk drive	36
Using the ac power adapter and the battery pack	11	Replacing a memory module	37
Checking the battery status	11	Replacing the PCI Express Mini Card for wireless LAN/WiMAX connection	39
Using the ac power adapter	12	Removing the optical drive	40
Charging the battery	12		
Maximizing the battery life	13	Chapter 8. Preventing problems	43
Handling the battery	13	General tips for preventing problems	43
Using the touch pad	14	Taking care of your computer	44
Using the keyboard	14		
Numeric keypad	14	Chapter 9. Troubleshooting computer problems	47
Using the recovery button	16	Troubleshooting	47
Function key combinations	16	Battery and power problems	47
Connecting to external devices	18	Computer screen problems	48
Using the media card reader	18	Problems with drives and other storage devices	49
Using USB connectors	19	OneKey Recovery Pro program problems	50
Using the NVIDIA Optimus Graphics feature	19	A password problem	50
		A sound problem	51
		Other problems	51
Chapter 3. Connecting to the network	21	Appendix A. Regulatory information	53
Wired connection	21	Wireless related information	53
Hardware connection	21	ENERGY STAR model information	54
Software configuration	22		
Wireless connection	22		

Export classification notice	55
Electronic emission notices.	55
Federal Communications Commission (FCC)	
Declaration of Conformity	55

Appendix B. WEEE and recycling statements	59
China WEEE statement	59
Important WEEE Information	59
Japan recycling statements	59
Recycling information for Brazil	60
Battery recycling information for the European Union	61
Battery recycling information for the United States and Canada.	61

Battery recycling information for Taiwan.	61
---	----

Appendix C. Restriction of Hazardous Substances Directive (RoHS)	63
China RoHS.	63
Turkish RoHS	63
Ukraine RoHS	63
India RoHS	64

Appendix D. Notices.	65
Trademarks	66

Index.	67
-----------------------	-----------

Read this first

Be sure to follow the important tips given here to continue to get the most use and enjoyment out of your computer. Failure to do so might lead to discomfort or injury, or cause your computer to fail.

Protect yourself from the heat that your computer generates.



When your computer is turned on or the battery is charging, the base, the palm rest, and some other parts may become hot. The temperature they reach depends on the amount of system activity and the level of charge in the battery.

Extended contact with your body, even through clothing, could cause discomfort or even a skin burn.

- Avoid keeping your hands, your lap, or any other part of your body in contact with a hot section of the computer for any extended time.
- Periodically take hands from using the keyboard by lifting your hands from the palm rest.

Protect yourself from the heat generated by the ac power adapter.



When the ac power adapter is connected to an electrical outlet and your computer, it generates heat.

Extended contact with your body, even through clothing, may cause a skin burn.

- Do not place the ac power adapter in contact with any part of your body while it is in use.
- Never use it to warm your body.

Prevent your computer from getting wet.



To avoid spills and the danger of electrical shock, keep liquids away from your computer.

Protect the cables from being damaged.

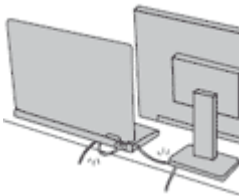

Applying strong force to cables may damage or break them.

Route communication lines, or the cables of an ac power adapter, a mouse, a keyboard, a printer, or any other electronic device, so that they cannot be walked on, tripped over, pinched by your computer or other objects, or in any way subjected to treatment that could interfere with the operation of your computer.

Protect your computer and data when moving it.



Before moving a computer equipped with a hard disk drive, do one of the following, and make sure that the power switch is off or is blinking:

- Turn it off.
- Put it in sleep mode.
- Put it in hibernation mode.

This will help to prevent damage to the computer, and possible loss of data.

Handle your computer gently.



Do not drop, bump, scratch, twist, hit, vibrate, push, or place heavy objects on your computer, display, or external devices.

Carry your computer carefully.



- Use a quality carrying case that provides adequate cushioning and protection.
- Do not pack your computer in a tightly packed suitcase or bag.
- Before putting your computer in a carrying case, make sure that it is off, in sleep mode, or in hibernation mode. Do not put a computer in a carrying case while it is turned on.

Important safety information

This information can help you safely use your notebook personal computer. Follow and retain all information included with your computer. The information in this document does not alter the terms of your purchase agreement or the Lenovo Limited Warranty.

Customer safety is important. Our products are developed to be safe and effective. However, personal computers are electronic devices. Power cords, power adapters, and other features can create potential safety risks that can result in physical injury or property damage, especially if misused. To reduce these risks, follow the instructions in this document carefully. By carefully following the information contained in this document and provided with your product, you can help protect yourself from hazards and create a safer computer work environment.

Conditions that require immediate action

Products can become damaged due to misuse or neglect. Some product damage is serious enough that the product should not be used again until it has been inspected and, if necessary, repaired by an authorized servicer.

As with any electronic device, pay close attention to the product when it is turned on. On very rare occasions, you might notice an odor or see a puff of smoke or sparks vent from your product. Or you might hear sounds like popping, cracking or hissing. These conditions might merely mean that an internal electronic component has failed in a safe and controlled manner. Or, they might indicate

a potential safety issue. However, do not take risks or attempt to diagnose the situation yourself. Contact the Customer Support Center for further guidance. For a list of Service and Support phone numbers, go to the following Web site:
<http://www.lenovo.com/support>

Frequently inspect your computer and its components for damage or wear or signs of danger. If you have any question about the condition of a component, do not use the product. Contact the Customer Support Center or the product manufacturer for instructions on how to inspect the product and have it repaired, if necessary.

In the unlikely event that you notice any of the following conditions, or if you have any safety concerns with your product, stop using the product and unplug it from the power source and telecommunication lines until you can speak to the Customer Support Center for further guidance.

- Power cords, plugs, power adapters, extension cords, surge protectors, or power supplies that are cracked, broken, or damaged.
- Signs of overheating, smoke, sparks, or fire.
- Damage to a battery (such as cracks, dents, or creases), discharge from a battery, or a buildup of foreign substances on the battery.
- A cracking, hissing or popping sound, or strong odor that comes from the product.
- Signs that liquid has been spilled or an object has fallen onto the computer product, the power cord or power adapter.
- The computer product, power cord, or power adapter has been exposed to water.
- The product has been dropped or damaged in any way.
- The product does not operate normally when you follow the operating instructions.

Note: If you notice these conditions with a product (such as an extension cord) that is not manufactured for or by Lenovo, stop using that product until you can contact the product manufacturer for further instructions, or until you get a suitable replacement.

Safety guidelines

Always observe the following precautions to reduce the risk of injury and property damage.

Service and upgrades

Do not attempt to service a product yourself unless instructed to do so by the Customer Support Center or your documentation. Only use a Service Provider who is approved to repair your particular product.

Note: Some computer parts can be upgraded or replaced by the customer. Upgrades typically are referred to as options. Replacement parts approved for customer installation are referred to as Customer Replaceable Units, or CRUs. Lenovo provides documentation with instructions when it is appropriate for customers to install options or replace CRUs. You must closely follow all instructions when installing or replacing parts. The Off state of a power indicator does not necessarily mean that voltage levels inside a product are zero. Before you remove the covers from a product equipped with a power cord, always make sure that the power is turned off and that the product is unplugged from any power source. If you have any questions or concerns, contact the Customer Support Center.

CAUTION:



Before replacing any CRUs, turn off the computer and wait three to five minutes to let the computer cool before opening the cover.

Power cords and power adapters



DANGER

Use only the power cords and power adapters supplied by the product manufacturer.

The power cords shall be safety approved. For Germany, it shall be H05VV-F, 3G, 0.75 mm², or better. For other countries, the suitable types shall be used accordingly.

Never wrap a power cord around a power adapter or other object. Doing so can stress the cord in ways that can cause the cord to fray, crack, or crimp. This can present a safety hazard.

Always route power cords so that they will not be walked on, tripped over, or pinched by objects.

Protect power cords and power adapters from liquids. For instance, do not leave your power cord or power adapter near sinks, tubs, toilets, or on floors that are cleaned with liquid cleansers. Liquids can cause a short circuit, particularly if the power cord or power adapter has been stressed by misuse. Liquids also can cause gradual corrosion of power cord terminals and/or the connector terminals on a power adapter, which can eventually result in overheating.

Always connect power cords and signal cables in the correct order and ensure that all power cord connectors are securely and completely plugged into receptacles.

Do not use any power adapter that shows corrosion at the ac input pins or shows signs of overheating (such as deformed plastic) at the ac input pins or anywhere on the power adapter.

Do not use any power cords where the electrical contacts on either end show signs of corrosion or overheating or where the power cord appears to have been damaged in any way.

To prevent possible overheating, do not cover the power adapter with clothing or other objects when the power adapter is plugged into an electrical outlet.

Extension cords and related devices

Ensure that extension cords, surge protectors, uninterruptible power supplies, and power strips that you use are rated to handle the electrical requirements of the product. Never overload these devices. If power strips are used, the load should not exceed the power strip input rating. Consult an electrician for more information if you have questions about power loads, power requirements, and input ratings.

Plugs and outlets



DANGER

If a receptacle (power outlet) that you intend to use with your computer equipment appears to be damaged or corroded, do not use the outlet until it is replaced by a qualified electrician.

Do not bend or modify the plug. If the plug is damaged, contact the manufacturer to obtain a replacement.

Do not share an electrical outlet with other home or commercial appliances that draw large amounts of electricity; otherwise, unstable voltage might damage your computer, data, or attached devices.

Some products are equipped with a three-pronged plug. This plug fits only into a grounded electrical outlet. This is a safety feature. Do not defeat this safety feature by trying to insert it into a non-grounded outlet. If you cannot insert the plug into the outlet, contact an electrician for an

approved outlet adapter or to replace the outlet with one that enables this safety feature. Never overload an electrical outlet. The overall system load should not exceed 80 percent of the branch circuit rating. Consult an electrician for more information if you have questions about power loads and branch circuit ratings.

Be sure that the power outlet you are using is properly wired, easily accessible, and located close to the equipment. Do not fully extend power cords in a way that will stress the cords.

Be sure that the power outlet provides the correct voltage and current for the product you are installing.

Carefully connect and disconnect the equipment from the electrical outlet.

Power supply statement



Never remove the cover on a power supply or any part that has the following label attached.



Hazardous voltage, current, and energy levels are present inside any component that has this label attached. There are no serviceable parts inside these components. If you suspect a problem with one of these parts, contact a service technician.

External devices

CAUTION:

Do not connect or disconnect any external device cables other than Universal Serial Bus (USB) cable while the computer power is on; otherwise, you might damage your computer. To avoid possible damage to attached devices, wait at least five seconds after the computer is shut down to disconnect external devices.

General battery notice



Personal computers manufactured by Lenovo contain a coin cell battery to provide power to the system clock. In addition, many mobile products, such as notebook computers, utilize a rechargeable battery pack to provide system power when in portable mode. Batteries supplied by Lenovo for use with your product have been tested for compatibility and should only be replaced with approved parts.

Never attempt to open or service any battery. Do not crush, puncture, or incinerate batteries or short circuit the metal contacts. Do not expose the battery to water or other liquids. Only recharge the battery pack strictly according to instructions included in the product documentation.

Battery abuse or mishandling can cause the battery to overheat, which can cause gasses or flame to “vent” from the battery pack or coin cell. If your battery is damaged, or if you notice any

discharge from your battery or the buildup of foreign materials on the battery leads, stop using the battery and obtain a replacement from the battery manufacturer.

Batteries can degrade when they are left unused for long periods of time. For some rechargeable batteries (particularly Lithium Ion batteries), leaving a battery unused in a discharged state could increase the risk of a battery short circuit, which could shorten the life of the battery and also can pose a safety hazard. Do not let rechargeable Lithium-Ion batteries completely discharge or store these batteries in a discharged state.

Rechargeable battery notice



DANGER

Do not attempt to disassemble or modify the battery pack. Attempting to do so can cause an explosion, or liquid leakage from the battery pack. A battery pack other than the one specified by Lenovo, or a disassembled or modified battery pack is not covered by the warranty.

If the rechargeable battery pack is incorrectly replaced, there is danger of an explosion. The battery pack contains a small amount of harmful substances. To avoid possible injury:

- Replace only with a battery of the type recommended by Lenovo.
- Keep the battery pack away from fire.
- Do not expose it to water or rain.
- Do not attempt to disassemble it.
- Do not short-circuit it.
- Keep it away from children.
- Do not drop the battery pack.

Do not put the battery pack in trash that is disposed of in landfills. When disposing of the battery, comply with local ordinances or regulations.

The battery pack should be stored at room temperature, charged to approximately 30 to 50% of capacity. We recommend that battery pack be charged about once per year to prevent overdischarge.

Lithium coin cell battery notice



DANGER

Danger of explosion if battery is incorrectly replaced.

When replacing the lithium coin cell battery, use only the same or an equivalent type that is recommended by the manufacturer. The battery contains lithium and can explode if not properly used, handled, or disposed of.

Do not:

- Throw or immerse into water
- Heat to more than 100°C (212°F)
- Repair or disassemble

Dispose of the battery as required by local ordinances or regulations.

The following statement applies to users in the state of California, U.S.A.

California Perchlorate Information:

Products containing manganese dioxide lithium coin cell batteries may contain perchlorate.

Perchlorate Material - special handling may apply, See www.dtsc.ca.gov/hazardouswaste/perchlorate

Heat and product ventilation



Computers, ac power adapters, and many accessories can generate heat when turned on and when batteries are charging. Notebook computers can generate a significant amount of heat due to their compact size. Always follow these basic precautions:

- When your computer is turned on or the battery is charging, the base, the palm rest, and some other parts may become hot. Avoid keeping your hands, your lap, or any other part of your body in contact with a hot section of the computer for any extended length of time. When you use the keyboard, avoid keeping your palms on the palm rest for a prolonged period of time. Your computer generates some heat during normal operation. The amount of heat depends on the amount of system activity and the battery charge level. Extended contact with your body, even through clothing, could cause discomfort or even a skin burn. Periodically take breaks from using the keyboard by lifting your hands from the palm rest; and be careful not to use the keyboard for any extended length of time.
- Do not operate your computer or charge the battery near flammable materials or in explosive environments.
- Ventilation slots, fans and/or heat sinks are provided with the product for safety, comfort, and reliable operation. These features might inadvertently become blocked by placing the product on a bed, sofa, carpet, or other flexible surface. Never block, cover, or disable these features.
- When the ac power adapter is connected to an electrical outlet and your computer, it generates heat. Do not place the adapter in contact with any part of your body while using it. Never use the ac power adapter to warm your body. Extended contact with your body, even through clothing, may cause a skin burn.

For your safety, always follow these basic precautions with your computer:

- Keep the cover closed whenever the computer is plugged in.
- Regularly inspect the outside of the computer for dust accumulation.
- Remove dust from vents and any perforations in the bezel. More frequent cleanings might be required for computers in dusty or high-traffic areas.
- Do not restrict or block any ventilation openings.
- Do not operate your computer inside furniture, as this might increase the risk of overheating.
- Airflow temperatures into the computer should not exceed 35°C (95°F).

Electrical current safety information



DANGER

Electric current from power, telephone, and communication cables is hazardous.

To avoid a shock hazard:

- Do not use your computer during a lightning storm.
- Do not connect or disconnect any cables or perform installation, maintenance, or reconfiguration of this product during an electrical storm.
- Connect all power cords to a properly wired and grounded electrical outlet.
- Connect to properly wired outlets any equipment that will be attached to this product.
- Whenever possible, use one hand only to connect or disconnect signal cables.
- Never turn on any equipment when there is evidence of fire, water, or structural damage.
- Disconnect the attached power cords, battery pack, and all the cables before you open the device covers, unless instructed otherwise in the installation and configuration procedures.
- Do not use your computer until all internal parts enclosures are fastened into place. Never use the computer when internal parts and circuits are exposed.



DANGER

Connect and disconnect cables as described in the following procedures when installing, moving, or opening covers on this product or attached devices.

To connect:

1. Turn everything OFF.
2. First, attach all cables to devices.
3. Attach signal cables to connectors.
4. Attach power cords to outlets.
5. Turn devices ON.

To disconnect:

1. Turn everything OFF.
2. First, remove power cords from outlets.
3. Remove signal cables from connectors.
4. Remove all cables from devices.

The power cord must be disconnected from the wall outlet or receptacle before installing all other electrical cables connected to the computer.

The power cord may be reconnected to the wall outlet or receptacle only after all other electrical cables have been connected to the computer.

Laser compliance statement



CAUTION:

When laser products (such as CD-ROMs, DVD drives, fiber optic devices, or transmitters) are installed, note the following:

- Do not remove the covers. Removing the covers of the laser product could result in exposure to hazardous laser radiation. There are no serviceable parts inside the device.
- Use of controls or adjustments or performance of procedures other than those specified herein might result in hazardous radiation exposure.



Some laser products contain an embedded Class 3A or Class 3B laser diode. Note the following:

Laser radiation when open. Do not stare into the beam, do not view directly with optical instruments, and avoid direct exposure to the beam.

Liquid crystal display (LCD) notice

CAUTION:

For products with mercury-containing fluorescent lamps (for example, non-LED)

- **The fluorescent lamp in the liquid crystal display contains mercury; dispose of according to local, state, or federal laws.**
- **The LCD is made of glass, and rough handling or dropping the computer can cause the LCD to break. If the LCD breaks and the internal fluid gets into your eyes or on your hands, immediately wash the affected areas with water for at least 15 minutes; if any symptoms are present after washing, get medical care.**

Using headphones or earphones

CAUTION:

Excessive sound pressure from earphones and headphones can cause hearing loss. Adjustment of the equalizer to maximum increases the earphone and headphone output voltage and the sound pressure level. Therefore, to protect your hearing, adjust the equalizer to an appropriate level.

Excessive use of headphones or earphones for a long period of time at high volume can be dangerous if the output of the headphone or earphone connectors do not comply with specifications of EN 50332-2. The headphone output connector of your computer complies with EN 50332-2 Sub clause 7. This specification limits the computer's maximum wide band true RMS output voltage to 150 mV. To help protect against hearing loss, ensure that the headphones or earphones you use also comply with EN 50332-2 (Clause 7 limits) for a wide band characteristic voltage of 75 mV. Using headphones that do not comply with EN 50332-2 can be dangerous due to excessive sound pressure levels.

If your Lenovo computer came with headphones or earphones in the package, as a set, the combination of the headphones or earphones and the computer already complies with the specifications of EN 50332-1. If different headphones or earphones are used, ensure that they comply with EN 50332-1 (Clause 6.5 Limitation Values). Using headphones that do not comply with EN 50332-1 can be dangerous due to excessive sound pressure levels.

Additional safety information



Plastic bags can be dangerous. Keep plastic bags away from babies and children to avoid danger of suffocation.

Chapter 1. Getting to know your computer

This chapter introduces the computer hardware features to give you the basic information you will need to start using the computer.

- “Top view” on page 1
- “Left-side view” on page 2
- “Right-side view” on page 3
- “Front view” on page 4
- “Bottom view” on page 5
- “Status indicators” on page 5
- “Features” on page 7
- “Specifications” on page 8

Top view

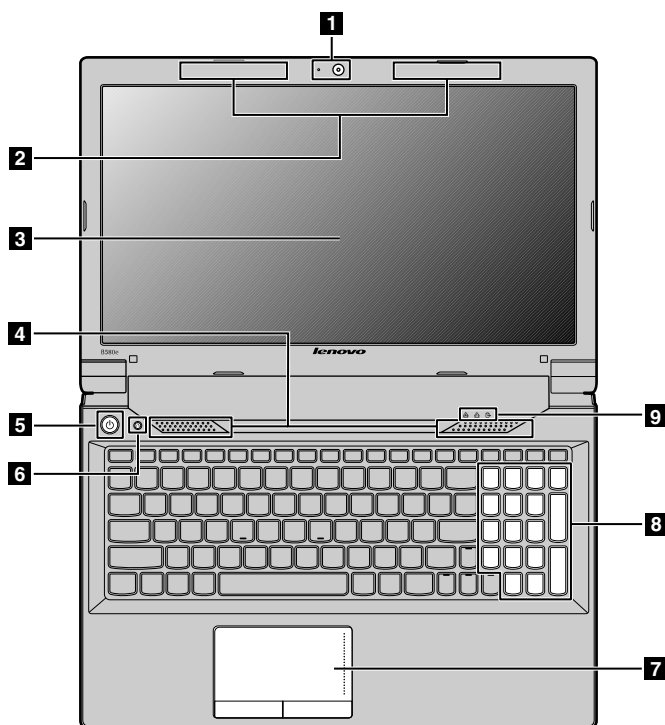

Figure 1. Top view

1 Integrated camera	6 Recovery button
2 Wireless module antennas	7 Touch pad
3 Computer display	8 Numeric keypad (for Lenovo B590 models)

4 Speakers	9 Status indicators
5 Power button	

Note: Your computer might look different from the above illustration.

1 Integrated camera

Use the camera to take pictures or hold a video conference.

2 Wireless module antennas

The built-in antennas ensure optimal reception of wireless radio.

3 Computer display

The LCD display provides brilliant visual output.

4 Built-in stereo speakers

To adjust the sound level of the built-in speakers, refer to “Function key combinations” on page 16.

5 Power button

Press this button to turn on the computer. To turn off the computer, refer to the instructions in “Putting the computer into sleep mode or shutting it down” on page 11.

6 Recovery button

On the Windows® operating system, press this button to launch the recovery program preinstalled on your computer. For more information, refer to “Using the recovery button” on page 16.

7 Touch pad

Move your fingertip across the touch pad to move the pointer. The touch pad buttons provide functions similar to those of a mouse and its buttons. For more information, refer to “Using the touch pad” on page 14.

8 Numeric keypad (for Lenovo B590 models)

Use the numeric keypad to input numbers quickly. For more information, refer to “Using the keyboard” on page 14.

9 Status indicators

The status indicators show the current status of your computer. For more information, refer to “Status indicators” on page 5.

Left-side view

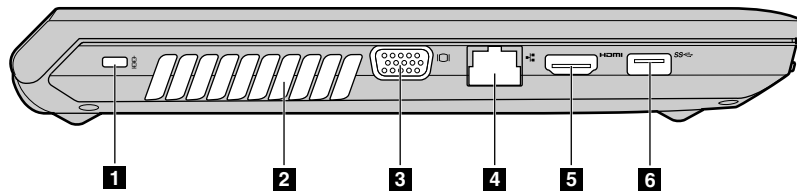

Figure 2. Left-side view

Note: Your computer might look different from the above illustration.

1 Security keyhole	4 Ethernet connector
2 Fan louvers	5 HDMI connector
3 Monitor connector	6 USB 3.0 connector

1 Security keyhole

Purchase a security cable lock that fits this keyhole to lock your computer to a stationary object to protect your computer from theft. For more information, refer to “Attaching a mechanical lock” on page 27.

2 Fan louvers

The internal fan and louvers enable air to circulate in the computer and cool the central processor.

Note: To avoid impeding airflow, do not place any obstacle in front of the fan.

3 Monitor connector

The monitor connector is used to connect an external monitor or projector to your computer.

4 Ethernet connector

Connect your computer to a local area network (LAN) with the Ethernet connector.



DANGER

To avoid the risk of electrical shock, do not connect the telephone cable to the Ethernet connector. You can only connect an Ethernet cable to this connector.

For more information, refer to “Wired connection” on page 21.

5 HDMI connector

Use the high-definition multimedia interface (HDMI) connector to connect a compatible digital audio device or video monitor such as an HDTV.

6 USB 3.0 connector

Connect devices compatible with a USB interface, such as a USB printer or a digital camera. For more information, refer to “Using USB connectors” on page 19.

Note: The USB 3.0 connector is compatible with USB 1.1, 2.0, and 3.0.

Right-side view

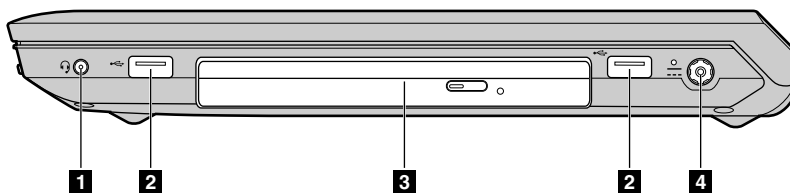

Figure 3. Right-side view

Note: Your computer might look different from the above illustration.

1 Combo audio jack	3 Optical drive
2 USB connectors	4 ac power connector

1 Combo audio jack

To listen to the sound from your computer, connect a headphone or a headset that has a 3.5 mm 4-pole plug to the combo audio jack.

2 USB connectors

Connect devices compatible with a USB interface, such as a USB printer or a digital camera. For more information, refer to “Using USB connectors” on page 19.

Note: The USB connectors are compatible with USB 1.1 and 2.0.

3 Optical drive

The optical drive reads optical discs.

4 ac power connector

The ac power adapter cable connects to the computer ac power connector to provide power to the computer and charge the battery. For more information, refer to “Using the ac power adapter and the battery pack” on page 11.

Front view



Figure 4. Front view

Note: Your computer might look different from the above illustration.

1 Status indicators	3 Media card reader slot
2 Built-in microphone	

1 Status indicators

The status indicators show the current status of your computer. For more information, refer to “Status indicators” on page 5.

2 Built-in microphone

The built-in microphone captures sound and voice when it is used with an application program capable of handling audio.

3 Media card reader slot

For more information, refer to “Using the media card reader” on page 18.

Bottom view

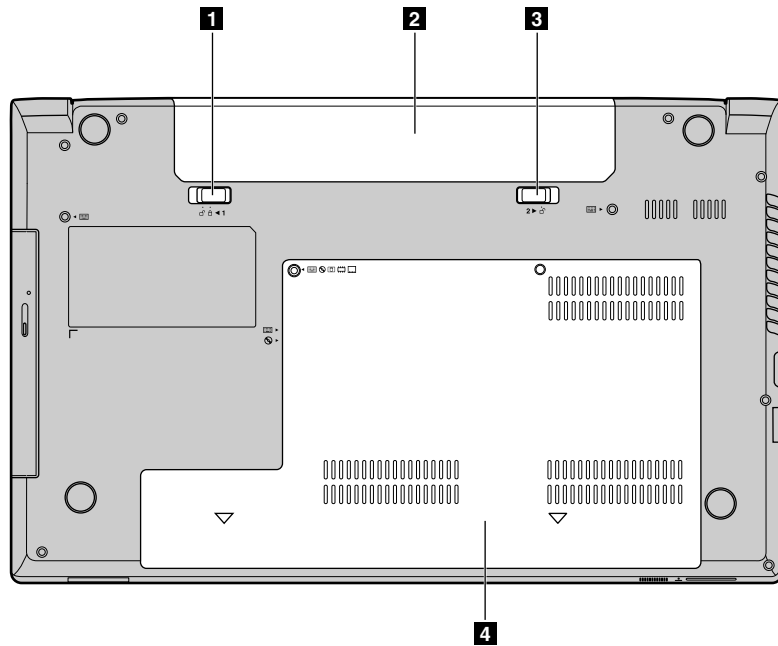

Figure 5. Bottom view

Note: Your computer might look different from the above illustration.

1 Battery latch (manual)	3 Battery latch (spring-loaded)
2 Battery	4 Bottom slot cover

1 Battery latch (manual)

Keeps the battery secured in place.

2 Battery

Use your computer with battery power whenever ac power is unavailable. For more information, refer to “Using the ac power adapter and the battery pack” on page 11.

3 Battery latch (spring-loaded)

Keeps the battery secured in place.

4 Bottom slot cover

The hard disk drive, memory module, and mini-PCI Express Card are placed underneath.

Status indicators

The status indicators show the current status of your computer.

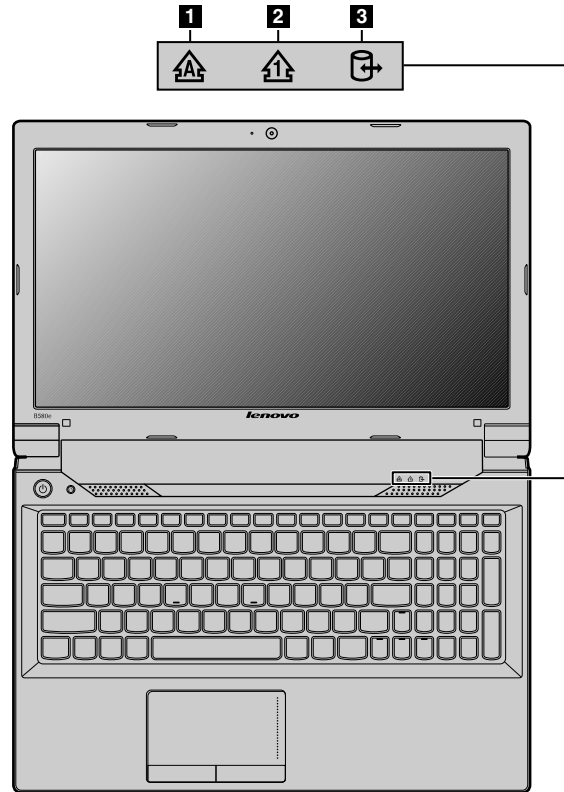

Figure 6. Status indicators

Note: Your computer might look different from the above illustration.

1 Caps Lock indicator

When the indicator is on, the Caps Lock mode is enabled. You can type all alphabetic characters (A-Z) in upper case directly.

2 Numeric Lock indicator

When the indicator is on, the numeric keypad is enabled. You can use the keypad to type numbers quickly.

3 Device access status indicator

When this indicator is on, the hard disk drive or the optical drive is reading or writing data.

Attention:

- When the indicator is on, do not put the computer into sleep mode or turn off the computer.
- When the indicator is on, do not move the computer. Sudden physical shock might cause drive errors.

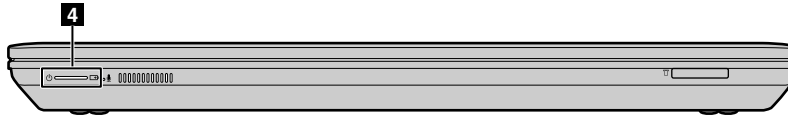

Figure 7. Status indicators

Note: Your computer might look different from the above illustration.

4 Power and battery status indicator

- **Green:** The battery charge level is between 80% and 100%, or the battery discharge level is between 20% and 100%.
- **Slow blinking green:** The battery charge level is between 20% and 80%, and charging is continuing. When the battery charge level reaches 80%, the battery status indicator stops blinking, but the charging might continue until the battery is 100% charged.
- **Slow blinking orange:** The battery charge level is between 5% and 20%, and the charging is continuing. When the battery charge level reaches 20%, the blinking color changes to green.
- **Orange:** The battery discharge level is between 5% and 20%.
- **Fast blinking orange:** The battery charge or discharge level is 5% or less.
- **Off:** The battery is detached or the computer is powered off.

Features

This topic lists the physical features for your computer.

Processor

- To view the processor information of your computer, do either of the following:
 - For the Windows 7 operating system: Click **Start**, right-click **Computer**. Then click **Properties**.
 - For the Windows 8 operating system: From the desktop, move the cursor to the top-right or bottom-right corner of the screen to display the charms. Then click **Settings** → **PC info**.

Memory

- Double data rate 3 (DDR3) synchronous dynamic random access memory (SDRAM)

Storage device

- 2.5-inch (7 mm height or 9.5 mm height) hard disk drive

Display

- Size:
 - 14.0 inches (356 mm)
 - 15.6 inches (396 mm for Lenovo B590 models)
- Resolution:
 - LCD: 1366-by-768
 - External monitor: Maximum 2048-by-1536
- Integrated camera
- Built-in microphones

Keyboard

- 6-row Lenovo keyboard
- Recovery button

Interface

- Combo audio jack
- USB 2.0 connectors
- USB 3.0 connectors
- RJ45 Ethernet connector
- HDMI connector
- External monitor connector
- 4-in-1 digital media card reader slot

Optical drive

- 12.7 mm Rambo optical drive (on some models)

Wireless features

- Integrated wireless LAN
- Integrated WiMAX
- 100/1000Mbps Ethernet communication

Specifications

This topic lists the physical specifications for your computer.

Heat output

- 65 W (222 Btu/hr) or 90 W (307 Btu/hr) maximum heat output (depending on the model)

Power source (ac power adapter)

- Sine-wave input at 50 to 60 Hz
- Input rating of the ac power adapter: 100 to 240 V ac, 50 to 60 Hz

Battery pack

- Lithium-ion (Li-Ion) battery pack

Chapter 2. Using your computer

This chapter provides information on using some of the computer components.

- “Frequently asked questions” on page 9
- “Tips on using your computer” on page 10
- “Using the ac power adapter and the battery pack” on page 11
- “Using the touch pad” on page 14
- “Using the keyboard” on page 14
- “Connecting to external devices” on page 18
- “Using the NVIDIA Optimus Graphics feature” on page 19

Frequently asked questions

The following are a few tips that will help you optimize the use of your computer.

- **Question:** Can I get my user guide in another language?
Solution: To download the user guide in another language, go to <http://www.lenovo.com/UserManuals>. Then follow the instructions on the screen.
- **Question:** What safety precautions should I follow when using my computer?
Solution: See “Important safety information” in the *Safety, Warranty, and Setup Guide* that comes with your computer.
- **Question:** How can I prevent problems with my computer?
Solution: See Chapter 8 “Preventing problems” on page 43.
- **Question:** What are the main hardware features of my computer?
Solution: See Chapter 1 “Getting to know your computer” on page 1 and Chapter 2 “Using your computer” on page 9.
- **Question:** Where can I find the detailed specifications for my computer?
Solution: Go to <http://www.lenovo.com/support>.
- **Question:** Where can I find the instructions on upgrading or replacing a device?
Solution: See Chapter 7 “Replacing devices” on page 33.
- **Question:** Where are the recovery discs?
Solution: Your computer does not come with a recovery disc. For an explanation of the alternative recovery solutions for your computer, see Chapter 6 “Recovery overview” on page 29.
- **Question:** How can I contact the Customer Support Center?
Solution: See “Service and Support information” in the *Safety, Warranty, and Setup Guide* that comes with your computer.
- **Question:** Where can I find the warranty information?
Solution: For the warranty applicable to your computer, including the warranty period and type of warranty service, see *Safety, Warranty, and Setup Guide* that comes with your computer.
- **Question:** How can I install the device drivers?
Solution: A compatible device driver is a requirement to ensure correct operation and performance of each component in your computer. If your computer is preinstalled with an operating system, Lenovo provides all device drivers that you need on the hard disk drive.

- **Question:** Where can I download the latest drivers?

Solution: The latest drivers for your computer are available from the Lenovo Support Web site. To download the latest drivers for your computer, go to <http://www.lenovo.com/drivers>. Then follow the instructions on the screen.

- **Question:** What can I do if the backup process fails?

Solution: If you can start the backup feature without a problem, but it fails during the backup process, try the following:

1. Close other applications, then restart the backup process.
2. Check if the destination medium is damaged, try to select another file path and then try again.

- **Question:** When do I need to restore the computer to the factory default settings?

Solution: You can restore the computer to the factory default settings when it fails or when you need to reinstall the operating system. This will restore your computer back to the initial state when you first started it up after receiving it from the store. Ensure that you have backed up your critical data before doing this to avoid data loss.

Tips on using your computer

This topic provides tips on using your computer for the first time.

Reading the manuals

Read the manuals that come with your computer before using the computer.

Connecting to power

The supplied battery pack is not fully charged at purchase. To charge the battery and begin to use your computer, install the battery pack, connect the computer to an electrical outlet, and then the battery will be charged automatically.

Installing the battery pack

For instructions on installing the battery pack, refer to the *Safety, Warranty, and Setup Guide* that comes with your computer.

Connecting the computer to an electrical outlet

To connect the computer to an electrical outlet, do the following:

1. Plug the power cord into an electrical outlet.
2. Connect the power cord to the transformer pack.
3. Insert the power jack into the computer.

Turning on the computer

Press the power button to turn on the computer.

Configuring the operating system

You might need to configure the operating system when you use the computer for the first time. The configuration process might include the following steps:

- Accepting the end user license agreement
- Configuring the Internet connection
- Registering the operating system

- Creating a user account

Putting the computer into sleep mode or shutting it down

To conserve power, put the computer into sleep mode or shut it down when the computer is not in use.

Putting your computer into sleep mode

If you will be away from your computer for a short time, put the computer into sleep mode. When the computer is in sleep mode, you can quickly wake it up to resume use and bypass the startup process.

To put the computer into sleep mode, do either of the following:

- **For the Windows 7 operating system:**
 1. Click **Start**.
 2. Select **Sleep** from the **Shut down** menu options.

For the Windows 8 operating system:

1. Move your cursor to the lower-right corner of the screen, and then the charms is displayed.
 2. Click **Settings**.
 3. Select **Sleep** from the **Power** menu options.
- Press Fn+F1.

Note: Wait until the power indicator starts blinking (indicating that the computer is in sleep state) before you move the computer. Moving the computer while the hard disk drive is spinning can damage the hard disk drive, causing loss of data.

To wake up the computer, do either of the following:

- Press the power button.
- Press the Fn key on the keyboard.

Shutting down the computer

If you are not going to use the computer for a day or two, shut it down.

To shut down the computer, do either of the following:

- **For the Windows 7 operating system:** Click **Start** → **Shut down**.
- **For the Windows 8 operating system:**
 1. Move your cursor to the lower-right corner of the screen, and then the charms is displayed.
 2. Click **Settings**.
 3. Select **Shut down** from the **Power** menu options.

Using the ac power adapter and the battery pack

This topic provides information about how to use the ac power adapter and the battery for your computer.

Checking the battery status

The battery gauge in the Windows notification area displays the percentage of battery power remaining.

The rate at which you use battery power will determine how long you can use the battery between charges. Because each computer user has different habits and needs, it is difficult to predict how long a battery charge will last. There are two main factors:

- How much energy is stored in the battery when you begin to work.
- The way you use your computer: how often you access the hard disk drive, how bright you make the computer display.

Using the ac power adapter

The power to run your computer can come either from the lithium-ion battery pack provided with it, or from ac power through the ac power adapter. While you use ac power, the battery charges automatically.

The ac power adapter has two basic components:

1. The transformer pack that converts ac power for use with the computer.
2. The power cord that plugs into the ac outlet and into the transformer pack.

Attention: Using an improper power cord could cause severe damage to the computer.

Connecting the ac power adapter

To connect the ac power adapter, do the following:

1. Plug the power cord into an electrical outlet.
2. Connect the power cord to the transformer pack.
3. Insert the power jack into the computer.

Tips on using the ac power adapter

When using the ac power adapter, observe the following guidelines:

- When the ac power adapter is not in use, disconnect it from the electrical outlet.
- Do not bind the power cord tightly around the ac power transformer pack when it is connected to the transformer.
- Before you charge the battery, make sure that its temperature is at least 10°C (50°F).
- You can charge the battery when the ac power adapter is connected to the computer and the battery is installed.

Charging the battery

When you find that the battery power is low, you need to charge the battery or replace it with a fully charged one.

You are recommended to charge the battery in any of the following situations:

- When you purchase a new battery
- If the battery status indicator starts blinking
- If the battery has not been used for a long time

Notes:

- You are advised to install the battery pack when using your computer to prevent small particles from entering the inside of your computer.
- To maximize the battery life, do not start recharging the battery immediately after it drops from full charge.
- Charge the battery at a temperature between 50 °F and 86 °F (10 °C-30 °C).
- Full charge or discharge is not required.

Maximizing the battery life

To maximize the life of a new battery or a battery that you have not used recently, do either of the following:

- Use the battery until the charge is completely depleted; that is, use the battery until the battery status indicator starts blinking orange.
- Recharge the battery completely before using it. The battery is fully charged if the battery indicator shows green when the ac power adapter is plugged in.

Handling the battery



DANGER

Do not attempt to disassemble or modify the battery pack.

Attempting to do so can cause an explosion, or liquid leakage from the battery pack.

A battery pack other than the one specified by Lenovo, or a disassembled or modified battery pack is not covered by the warranty.



DANGER

If the rechargeable battery pack is incorrectly replaced, there is danger of an explosion. The battery pack contains a small amount of harmful substances. To avoid possible injury:

- **Replace only with a battery of the type recommended by Lenovo.**
- **Keep the battery pack away from fire.**
- **Do not expose it to excessive heat.**
- **Do not expose it to water or rain.**
- **Do not short-circuit it.**
- **Store it in a cool dry place.**

- Keep it away from children.

Using the touch pad



Figure 8. Touch pad

Note: Your computer might look different from the above illustration.

1 Touch pad: To move the cursor on the screen, slide your fingertip over the pad in the direction in which you want the cursor to move.

2 Left click button: Functions the same as the left button on a conventional mouse.

3 Right click button: Functions the same as the right button on a conventional mouse.

Note: You can enable or disable the touch pad by pressing Fn+F6.

Using the keyboard

Your computer has a numeric keypad and function keys incorporated in its standard keyboard.

Numeric keypad

Depending on your model, your computer might come with a separate numeric keypad or function keys that could work as a numeric keypad.

10-key numeric keypad

The keyboard has keys that can work as a 10-key numeric keypad when enabled. To enable or disable the keypad, press Fn+F8. The 10-key numeric keypad is for the following models: Lenovo B490, B4301, B4302, B4303, B4305, B4306, B4307, B4308, B4309, B4310, B4311, B4312, B4315, B4316, B4317, B4318, B4319, B4320, B4321, B4322, B4323, B4325, B4326, B4327, B4328, B4329, B4330, B4331, B4332, B4333, B4335, B4336, B4337, B4338, B4339, B4360, B4361, B4362, B4363, B4365, B4366, B4367, B4368, B4369, B4370, B4371, B4372, B4375, B4376, B4377, and B4378.

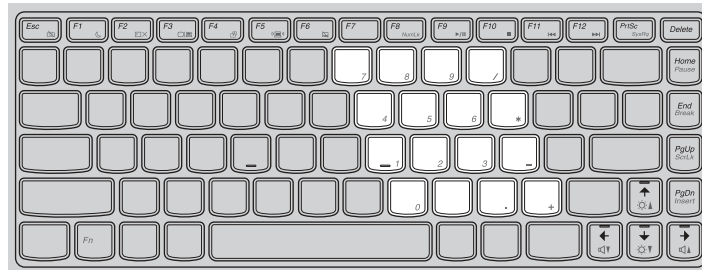

Separate numeric keypad

The keyboard has a separate numeric keypad. To enable or disable the keypad, press the Numeric Lock key (Num Lock). The separate numeric keypad is for Lenovo B590 models.

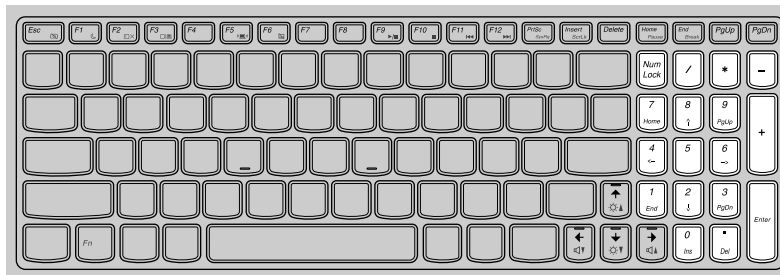

Note: The numeric lock indicator is on when the numeric keypad is enabled.

Using the recovery button

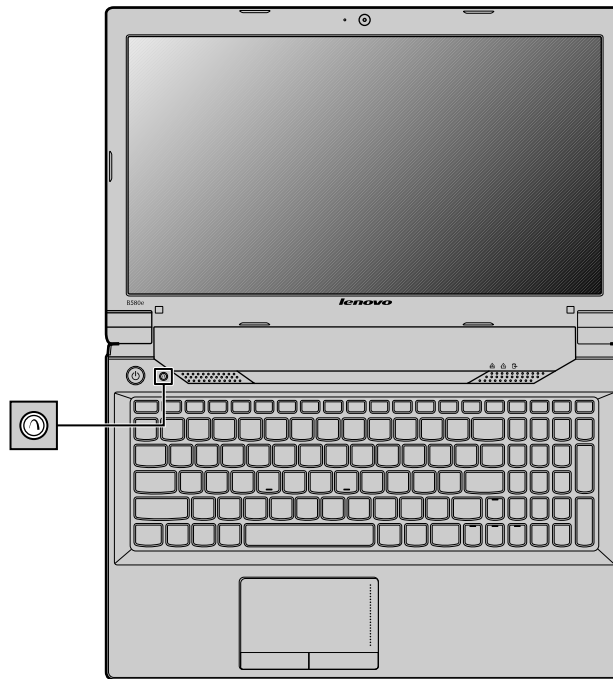

Note: Your computer might look different from the above illustration.

The recovery button enables you to launch the recovery programs preinstalled on your computer.

- For the Windows 7 operating system:
 - When the computer is turned off, press this button and then follow the on-screen instructions to launch the Product Recovery program.
 - When the computer is starting up and the Lenovo logo is displayed, press this button and then follow the on-screen instructions to start the Product Recovery program.
 - After you have entered the Windows operating system, press this button to launch the Lenovo Solution Center program.
- For the Windows 8 operating system: After you have entered the Windows operating system, press this button to launch the Lenovo Solution Center program.

For more information, refer to Chapter 6 “Recovery overview” on page 29.

Function key combinations

To use the function key combinations, press the Fn key **1**, then press one of the function keys **2**.



Note: Your computer might look different from the above illustration.

The following is a brief introduction to the function key combinations.

Launching the camera settings (Fn+Esc)

- On the Windows 7 operating system: Press Fn+Esc to open the camera and audio settings window. The camera preview is turned on. Change the camera and audio settings as desired.
- On the Windows 8 operating system: Press Fn+Esc to enable or disable the camera.

Volume controls (Fn + Left/Right arrow)

To adjust the sound volume from your computer, do the following:

- **Fn + Left arrow:** Decrease the sound volume.
- **Fn + Right arrow:** Increase the sound volume.

Adjusting display brightness level (Fn + Up/Down arrow)

You can temporarily change the computer display brightness level by pressing the two key combinations. When you press Fn + Up arrow, the computer display becomes brighter. When you press Fn + Down arrow, the computer display becomes dimmer.

Power conservation (Fn+F1)

Put your computer into sleep mode. To return to normal operation, press the Fn key only.

Display backlight feature (Fn+F2)

Press Fn+F2 to enable or disable the display backlight feature.

Switching the display output location (Fn+F3)

Press this function key combination to switch between the computer display and an external monitor. The following options will be displayed:

- **PC screen only**
- **Duplicate**
- **Extend**
- **Second screen only**

Note: To switch between the computer display and an external monitor, the Windows+P key combination also is available.

Wireless radio control (Fn+F5)

Press this key combination to enable or disable the built-in wireless networking features.

Touch pad controls (Fn+F6)

Press Fn+F6 to enable or disable the touch pad function on your computer.

Numeric keypad controls (Fn+F8)

For the following models, press Fn+F8 to enable or disable the numeric keypad: Lenovo B490, B4301, B4302, B4303, B4305, B4306, B4307, B4308, B4309, B4310, B4311, B4312, B4315, B4316, B4317, B4318, B4319, B4320, B4321, B4322, B4323, B4325, B4326, B4327, B4328, B4329, B4330, B4331, B4332, B4333, B4335, B4336, B4337, B4338, B4339, B4360, B4361, B4362, B4363, B4365, B4366, B4367, B4368, B4369, B4370, B4371, B4372, B4375, B4376, B4377, and B4378.

Multimedia controls

- Fn+F9: Play or Pause

- Fn+F10: Stop
- Fn+F11: Previous track or scene
- Fn+F12: Next track or scene.

Other functions

- **Fn+PgUp** : Enables or disables the Scroll Lock function.

Note: For Lenovo B590 models, press Fn+Insert to enable or disable the Scroll Lock function.

- **Fn+PrtSc**: Has the same function as the SysRq key on a conventional keyboard.
- **Fn+Home**: Has the same function as the Pause key on a conventional keyboard.
- **Fn+End**: Has the same function as the Break key on a conventional keyboard.
- **Fn+PgDn**: Has the same function as the Insert key on a conventional keyboard for the following models: Lenovo B490, B4301, B4302, B4303, B4305, B4306, B4307, B4308, B4309, B4310, B4311, B4312, B4315, B4316, B4317, B4318, B4319, B4320, B4321, B4322, B4323, B4325, B4326, B4327, B4328, B4329, B4330, B4331, B4332, B4333, B4335, B4336, B4337, B4338, B4339, B4360, B4361, B4362, B4363, B4365, B4366, B4367, B4368, B4369, B4370, B4371, B4372, B4375, B4376, B4377, and B4378.

Connecting to external devices

Your computer has a wide range of built-in features and connection capabilities.

Using the media card reader

Your computer supports the following cards:

- Secure Digital (SD) card
- Secure Digital High Capacity (SDHC) card
- SD eXtended Capacity (SDXC) card
- MultiMediaCard (MMC)

Notes:

- Your computer does not support the Content Protection for Recordable Media (CPRM) feature for the SD card.
- When transferring data to or from a flash media card, such as an SD card, do not put your computer in sleep or hibernation mode before the data transfer is complete. To do so might cause damage to your data.

Inserting a flash media card

To insert a flash media card, do the following:

1. Make sure that the card is correctly oriented.
2. Insert the card firmly into the 4-in-1 media card reader slot. The card might stop before it is completely installed into the slot.

Removing a flash media card

To remove a flash media card, do the following:

1. Push the flash media card until you hear a click.
2. Gently pull the flash media card out of the memory card slot.

Note: If you do not remove the card from your computer after you eject the card from the Windows operating system, the card can no longer be accessed. To access the card, you must remove it once, then insert it again.

Using USB connectors

Your computer is preinstalled with USB connectors compatible with USB 1.1, 2.0, or 3.0 devices.

Note: When using a high power consumption USB device such as a USB optical drive, use the power adapter that comes with the device. Otherwise, the device may not be recognized, and the system might be shut down.

Using the NVIDIA Optimus Graphics feature

Some Lenovo notebook computers support NVIDIA Optimus Graphics.

NVIDIA Optimus Graphics enables a dynamic switch, that is, a switch with no need to restart your computer between High Performance and Energy Saving.

Switching the Graphics Processing Unit

If your computer supports NVIDIA Optimus Graphics, the Graphics Processing Unit is switched automatically depending on the power settings you use.

Chapter 3. Connecting to the network

As a global network, the Internet connects computers worldwide, providing services such as e-mailing, information searching, electronic commerce, Web browsing, and entertainment.

You can connect the computer to the network in the following ways:

- “Wired connection” on page 21
- “Wireless connection” on page 22

Wired connection

It is a reliable and safe way to connect the computer to the Internet using a wired connection.

Wired connection	Description
Cable	Cable Internet services use a cable modem connected to the residential cable TV line.
Digital subscriber line (DSL)	DSL is a family of related technologies that bring high-speed network access to homes and small businesses over ordinary telephone lines.

Hardware connection

This topic provides information about how to connect to the Internet through hardware connection.

Cable

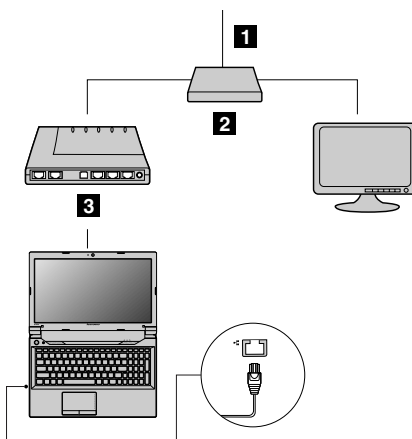

- 1** TV cable (not supplied)
- 2** Splitter (not supplied)
- 3** Cable modem (not supplied)

Note: Your wired connection might look different from the above illustrations.

DSL



- 1 Telephone line (not supplied)
- 2 Splitter (not supplied)
- 3 DSL modem (not supplied)

Note: Your wired connection might look different from the above illustrations.

Software configuration

Consult your Internet Service Provider (ISP) for details on how to configure your computer for wired connections.

Wireless connection

Wireless connections provide mobile access to the Internet, enabling you to stay online anywhere the wireless signal covers.

Divided by the signal scales, a wireless connection to the Internet can be established using the following standards.

Wireless connection	Description
Wi-Fi	Wi-Fi networks cover a small physical area, like a home, office, or small group of buildings. An access point is necessary for the connection.
WiMAX	WiMAX networks connect several Wireless LAN systems to cover a metropolitan area, providing high-speed broadband and provide high-speed broadband access.

To enable wireless communications, press Fn+F5.

Hardware connection

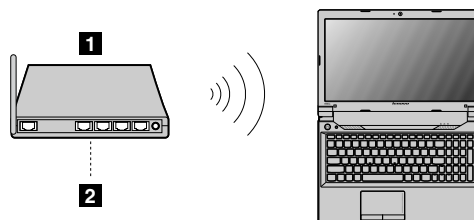

- 1 Wireless access point (not supplied)
- 2 Wi-Fi/WiMAX network

Software configuration

Consult your Internet Service Provider and search the Windows Help and Support Center for details on how to configure your computer for wireless connections.

Chapter 4. You and your computer

This chapter provides information about accessibility and comfort.

Accessibility and comfort

Good ergonomic practice is important to get the most from your personal computer and to avoid discomfort. Arrange your workplace and the equipment you use to suit your individual needs and the kind of work that you perform. In addition, use healthy work habits to maximize your performance and comfort while using your computer.

The following topics provide information about arranging your work area, setting up your computer equipment, and establishing healthy work habits.

Lenovo is committed to providing the latest information and technology to our customers with disabilities. Refer to our accessibility information which outlines our efforts in this area.

Ergonomic information

Working in the virtual office might mean adapting to frequent changes in your environment. Following some simple rules will make things easier and bring you the maximum benefits of your computer. Keeping in mind such basics as good lighting and proper seating, for example, can help you improve your performance and achieve greater comfort.

This example shows someone in a conventional setting. Even when not in such a setting, you can follow many of these tips. Develop good habits, and they will serve you well.

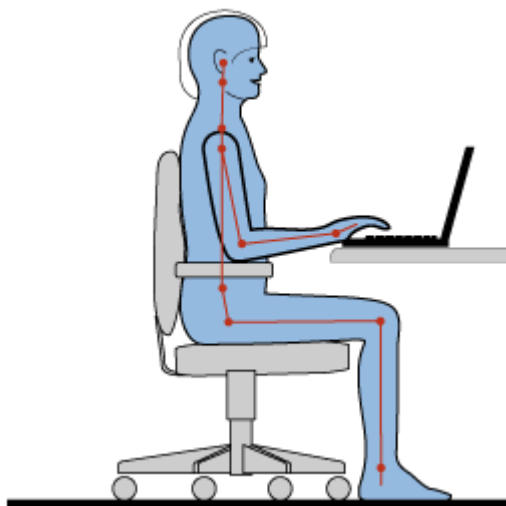

General posture: Make minor modifications in your working posture to deter the onset of discomfort caused by long periods of working in the same position. Frequent, short breaks from your work also help to prevent minor discomfort associated with your working posture.

Display: Position the display to maintain a comfortable viewing distance of 510-760 mm (20-30 inch). Avoid glare or reflections on the display from overhead lighting or outside sources of light. Keep the display screen

clean and set the brightness to levels that enable you to see the screen clearly. Press Fn + up/down arrow to adjust display brightness.

Head position: Keep your head and neck in a comfortable and neutral (vertical, or upright) position.

Chair: Use a chair that gives you good back support and seat height adjustment. Use chair adjustments to best suit your desired posture.

Arm and hand position: If available, use chair arm rests or an area on your working surface to provide weight support for your arms. Keep your forearms, wrists, and hands in a relaxed and neutral (horizontal) position. Type with a soft touch without pounding the keys.

Leg position: Keep your thighs parallel to the floor and your feet flat on the floor or on a footrest.

What if you are traveling?

It might not be possible to observe the best ergonomic practices when you are using your computer while on the move or in a casual setting. Regardless of the setting, try to observe as many of the tips as possible. Sitting properly and using adequate lighting, for example, will help you maintain desirable levels of comfort and performance.

Questions about vision?

The visual display screens of Lenovo notebook computers are designed to meet the highest standards and to provide you with clear, crisp images and large, bright displays that are easy to see, yet easy on the eyes. Of course, any concentrated and sustained visual activity can be tiring. If you have questions on eye fatigue or visual discomfort, consult a vision care specialist for advice.

Chapter 5. Security

This chapter provides information about protecting your computer from theft and unauthorized use.

Attaching a mechanical lock

You can attach a mechanical lock to your computer to prevent it from being removed without your permission.

Attach a mechanical lock to the keyhole of the computer; then secure the chain on the lock to a stationary object. Refer to the instructions shipped with the mechanical lock.

Note: You are responsible for evaluating, selecting, and implementing the locking devices and security features. Lenovo makes no comments, judgments, or warranties about the function, quality, or performance of locking devices and security features.

Using passwords

Using passwords helps prevent your computer from being used by others. Once you set a password and enable it, a prompt appears on the screen each time you power on the computer. Enter your password at the prompt. The computer cannot be used unless you enter the correct password.

Note: This password can be a combination of one to seven alphanumeric characters.

For more information about how to set the password, refer to the online help information system on the right screen of the BIOS.

Note: To enter the BIOS, press F1 when the Lenovo logo is displayed on the screen while the computer is starting up.

Chapter 6. Recovery overview

This chapter provides information about the recovery solutions for your computer.

- “Using the OneKey Recovery Pro program on the Windows 7 operating system” on page 29
- “Using the Windows recovery program on the Windows 8 operating system” on page 30

Using the OneKey Recovery Pro program on the Windows 7 operating system

On the Windows 7 operating system, the OneKey[®] Recovery Pro program enables you to do the following:

- Performing backup and recovery operations

The OneKey Recovery Pro program enables you to back up all your hard disk drive contents including the operating system, data files, software programs, and personal settings. You can designate where the OneKey Recovery Pro program stores the backup.

- Using the OneKey Recovery Pro workspace

The OneKey Recovery Pro workspace resides in a protected, hidden area of your hard disk drive that operates independently from the Windows operating system. This enables you to perform recovery operations even if you cannot start the Windows operating system. You can perform the following recovery operations from the OneKey Recovery Pro workspace.

- Creating and using a rescue medium

With a rescue medium, such as a disc or a USB hard disk drive, you can recover the computer from failures that prevent you from gaining access to the OneKey Recovery Pro workspace on your hard disk drive.

For more information, refer to the help information system of the OneKey Recovery Pro program.

Solving recovery problems on the Windows 7 operating system

To reinstall the Windows 7 operating system, do the following:

1. Turn off the computer.
2. Do one of the following:
 - Press the recovery button and then follow the on-screen instructions to launch the Product Recovery program.
 - Start the computer. When the Lenovo logo is displayed, press the recovery button and then follow the on-screen instructions to start the Product Recovery program.
 - Start the computer. After you have entered the Windows operating system, press the recovery button to launch the Lenovo Solution Center program.
3. Follow the on-screen instructions to reinstall the operating system.

Notes:

- You can choose to restore your system partition to the original factory state or to a previously generated backup.
- The recovery process is irreversible. Ensure that you have backed up your critical data before using the recovery feature.

If you are unable to access the OneKey Recovery Pro workspace or the Windows environment, do either of the following:

- Use a rescue medium to start the OneKey Recovery Pro workspace.
- Use recovery media if all other methods of recovery have failed and you need to restore the hard disk drive to the factory default settings.

Note: If you are unable to access the OneKey Recovery Pro workspace or the Windows environment from a rescue medium or recovery medium, you might not have the rescue device (an internal hard disk drive, a disc, a USB hard disk drive, or other external devices) set as the first boot device in the startup device sequence. You must first make sure that your rescue device is set as the first boot device in the startup device sequence in the BIOS program. Go to the **Startup → Boot** menu to temporarily or permanently change the startup device sequence.

It is important to create a rescue medium and a set of recovery media as early as possible and store them in a safe place for future use.

Using the Windows recovery program on the Windows 8 operating system

Your computer come with a built-in recovery program provided by Windows. On the Windows 8 operating system, the program enables you to do the following:

- **Refreshing your computer settings**

The refreshing enables you to restore your computer settings to factory contents only, without removing all the personal data and applications that you have installed from Windows Store.

To refresh your computer settings, do the following:

1. Move your cursor to the bottom right corner of the screen to bring up the charms. Then click **Settings → Change PC settings → General**.
2. In the **Refresh your PC without affecting your files** section, click **Get started**. Then follow the on-screen instructions to refresh your computer settings.

- **Resetting your computer settings**

When you use the recovery program to reset your computer settings, all the data you have stored on the hard disk drive will be deleted and the computer settings will be restored to the factory default settings.

Attention: To avoid data loss, back up all the data that will be in use later.

To reset your computer settings, do the following:

1. Move your cursor to the bottom right corner of the screen to bring up the charms. Then click **Settings → Change PC settings → General**.
2. In the **Remove everything and reinstall Windows** section, click **Get started**. Then follow the on-screen instructions to reset your computer settings.

Note: After restoring your computer settings to the factory contents, you might need to reinstall the drivers for some devices.

- **Advanced startup options**

Advanced startup options enable you to start up from an external drive or disc, change your computer settings, change the startup settings of the Windows operating system, or restore the Windows operating system from a system image.

To use the advanced startup option, do the following:

1. Move your cursor to the bottom right corner of the screen to bring up the charms. Then click **Settings → Change PC settings → General**.
2. In the **Advanced startup** section, click **Restart now → Troubleshoot → Advanced options**. Then follow the on-screen instructions to change the settings as desired.

For more information about the recovery solutions provided on your computer, refer to the online help information system of the Windows 8 operating system.

Chapter 7. Replacing devices

This chapter provides instructions on how to install or replace hardware for your computer.

- “Static electricity prevention” on page 33
- “Replacing the battery” on page 33
- “Replacing the backup battery” on page 34
- “Replacing the hard disk drive” on page 36
- “Replacing a memory module” on page 37
- “Replacing the PCI Express Mini Card for wireless LAN/WiMAX connection” on page 39
- “Removing the optical drive” on page 40

Static electricity prevention

Static electricity, although harmless to you, can seriously damage computer components and options. Improper handling of static-sensitive parts can cause damage to the part. When you unpack an option or CRU, do not open the static-protective package containing the part until the instructions direct you to install it.

When you handle options or CRUs, or perform any work inside the computer, take the following precautions to avoid static-electricity damage:

- Limit your movement. Movement can cause static electricity to build up around you.
- Always handle components carefully. Handle adapters, memory modules, and other circuit boards by the edges. Never touch exposed circuitry.
- Prevent others from touching components.
- When you install a static-sensitive option or CRU, touch the static-protective package containing the part to a metal expansion-slot cover or other unpainted metal surface on the computer for at least two seconds. This reduces static electricity from the package and your body.
- When possible, remove the static-sensitive part from the static-protective packaging and install the part without setting it down. When this is not possible, place the static-protective packaging on a smooth, level surface and place the part on it.
- Do not place the part on the computer cover or other metal surface.

Replacing the battery

Before you start, print these instructions.

Note: Your computer might look different from the illustrations in this topic.

Note: This system does not support batteries that are not genuine Lenovo-made or authorized. The system will continue to boot, but may not charge unauthorized batteries.

Attention: Lenovo has no responsibility for the performance or safety of unauthorized batteries, and provides no warranties for failures or damage arising out of their use.

Prerequisites for the procedure



If the rechargeable battery pack is incorrectly replaced, there is danger of an explosion. The battery pack contains a small amount of harmful substances. To avoid possible injury:

- Replace only with a battery of the type recommended by Lenovo.
- Keep the battery pack away from fire.
- Do not expose it to excessive heat.
- Do not expose it to water or rain.
- Do not short-circuit it.
- Do not drop, crush, puncture, or subject to strong forces. Battery abuse or mishandling can cause the battery to overheat, which can cause gasses or flame to “vent” from the battery pack or coin cell.

To replace the battery, do the following:

1. Turn off the computer; then disconnect the ac power adapter and all cables from the computer. Wait three to five minutes to let the computer cool.
2. Close the computer display, and turn the computer over.
3. Unlock the battery latch **1**. Hold the battery lock lever in the unlocked position **2**, and then remove the battery pack **2**.

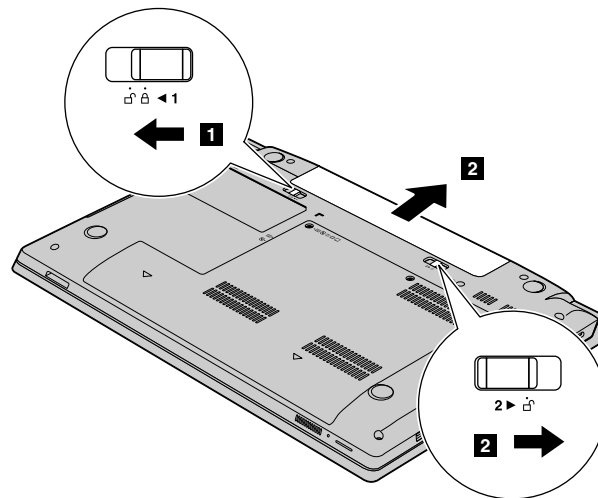

4. Insert a fully charged battery until it clicks into place.
5. Slide the manual battery latch to the locked position to secure the battery in place.
6. Turn the computer over again. Connect the ac power adapter and all cables.

Replacing the backup battery

Before you start, print these instructions.

Note: Your computer might look different from the illustrations in this topic.

Prerequisites for the procedure



If the backup battery is incorrectly replaced, there is danger of an explosion. The backup battery contains a small amount of harmful substances. To avoid possible injury:

- Replace only with a battery of the type recommended by Lenovo.
- Keep the battery pack away from fire.
- Do not expose it to excessive heat.
- Do not expose it to water or rain.
- Do not short-circuit it.
- Do not drop, crush, puncture, or subject to strong forces. Battery abuse or mishandling can cause the battery to overheat, which can cause gasses or flame to “vent” from the battery pack or coin cell.

To replace the backup battery, do the following:

1. Turn off the computer; then disconnect the ac power adapter and all cables from the computer. Wait three to five minutes to let the computer cool.
2. Close the computer display, and turn the computer over.
3. Remove the battery. See “Replacing the battery” on page 33.
4. Remove the screws **1**, and then remove the cover **2**.

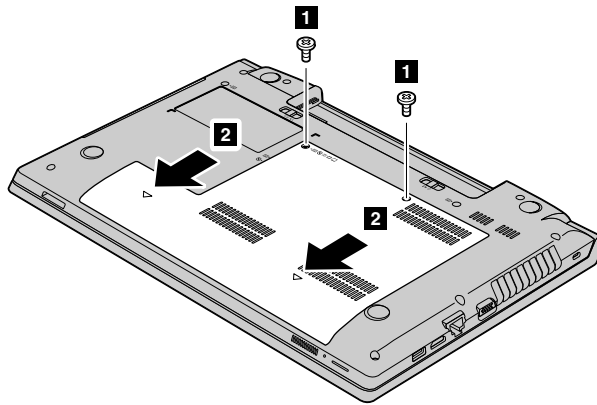

5. Insert a screwdriver into the backup battery hole and push the backup battery until the battery pops up.

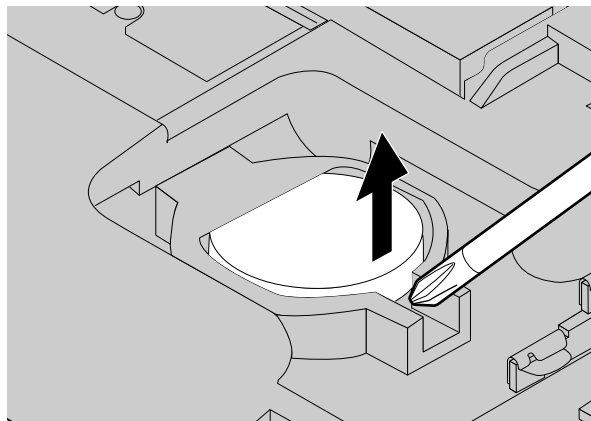

6. Install a new backup battery.
7. Reinstall the computer cover, and then reinstall the screws.
8. Reinstall the battery. See “Replacing the battery” on page 33.
9. Turn the computer over again. Connect the ac power adapter and all cables.

Replacing the hard disk drive

Before you start, print these instructions.

Note: Your computer might look different from the illustrations in this topic.

Prerequisites for the procedure

Attention: The hard disk drive is very sensitive. Incorrect handling can cause damage and permanent loss of data. Observe the following guidelines:

- Replace the hard disk drive only if you upgrade it or have it repaired. The connectors and slot of the hard disk drive are not designed for frequent changes, or drive swapping.
- Do not drop the drive or subject it to physical shocks. Put the drive on a material, such as soft cloth, that absorbs the physical shock.
- Do not apply pressure to the cover of the drive.
- Do not touch the connector.
- Before removing the hard disk drive, make a backup copy of all the information on it, and then turn the computer off.
- Never remove the drive while the computer is operating, in sleep mode, or in hibernation mode.

To replace the hard disk drive, do the following:

1. Turn off the computer; then disconnect the ac power adapter and all cables from the computer. Wait three to five minutes to let the computer cool.
2. Close the computer display, and turn the computer over.
3. Remove the battery. See “Replacing the battery” on page 33.
4. Remove the screws **1**, and then remove the cover **2**.

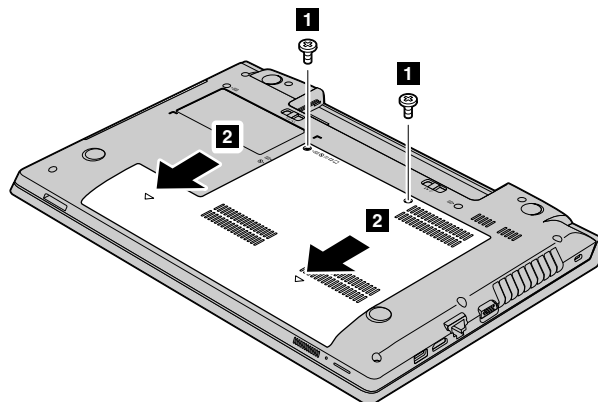

5. Remove the screw **3**, and then slide the hard disk drive out **4**.



6. Remove the hard disk drive by lifting the tab **5**.



7. Slide a new hard disk drive firmly into place, and then reinstall the screw to secure the drive.
8. Reinstall the computer cover, and then reinstall the screws to secure the cover.
9. Reinstall the battery. See “Replacing the battery” on page 33.
10. Turn the computer over again. Connect the ac power adapter and all cables.

Replacing a memory module

Before you start, print these instructions.

Note: Your computer might look different from the illustrations in this topic.

Prerequisites for the procedure

Note: The operating speed of the memory module has dependency on the system configuration. In some conditions, the memory module in your computer might not be able to operate at the maximum speed.

Attention: Before you start installing a memory module, touch a metal table or a grounded metal object. This action reduces any static electricity from your body. The static electricity could damage the memory module.

To replace a memory module, do the following:

1. Turn off the computer; then disconnect the ac power adapter and all cables from the computer. Wait three to five minutes to let the computer cool.
2. Close the computer display, and turn the computer over.
3. Remove the battery. See “Replacing the battery” on page 33.

4. Remove the screws **1**, and then remove the cover **2**.

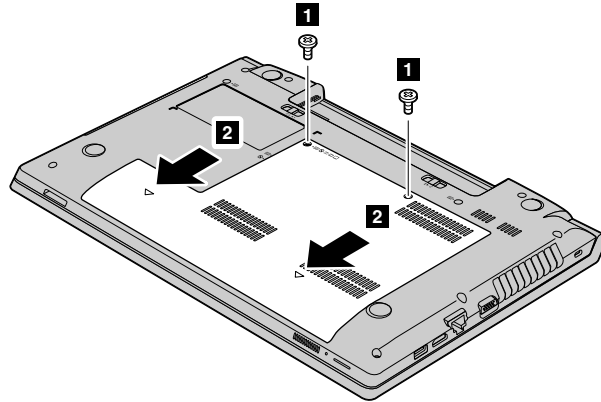

5. If two memory modules are already in the memory slots, press out on the latches on both edges of the socket at the same time **3**, and then remove a memory module to make room for the new one **4**. Save the removed memory module for future use.



6. Find the notch on the contact edge side of the memory module you are installing.

Attention: To avoid damaging the memory module, do not touch its contact edge.

7. With the notched end of the memory module toward the contact edge side of the socket, insert the memory module into the socket at an angle of about 20 degrees **5**; then press it in firmly **6**.



Note: If only one memory module is to be installed, install it in the bottom slot.

8. Pivot the memory module downward until it snaps into place.
9. Make sure that the memory module is firmly installed in the slot and cannot be moved easily.
10. Reinstall the computer cover, and then reinstall the screws to secure the cover.

11. Reinstall the battery. See “Replacing the battery” on page 33.
12. Turn the computer over again. Connect the ac power adapter and all cables.

Replacing the PCI Express Mini Card for wireless LAN/WiMAX connection

Before you start, print these instructions.

Note: Your computer might look different from the illustrations in this topic.

Your computer has a PCI Express Mini Card slot for connection to a wireless LAN/WiMAX. To replace the PCI Express Mini Card, read the following prerequisites.

Prerequisites for the procedure



During electrical storms, do not connect the cable to or disconnect it from the telephone outlet on the wall.



Electric current from power, telephone, and communication cables is hazardous. To avoid shock hazard, disconnect the cables before opening the cover of this slot.

Attention: Before you start installing a PCI Express Mini Card, touch a metal table or a grounded metal object. This action reduces any static electricity from your body. The static electricity could damage the card.

To replace the PCI Express Mini Card, do the following:

1. Turn off the computer; then disconnect the ac power adapter and all cables from the computer. Wait three to five minutes to let the computer cool.
2. Close the computer display, and turn the computer over.
3. Remove the battery. See “Replacing the battery” on page 33.
4. Remove the screws **1**, and then remove the cover **2**.



5. If a tool for removing connectors is included in the package with the new card, use it to disconnect the cables **3** from the card. If no such tool is included, disconnect the cables by picking up the connectors with your fingers and gently unplugging them. Then remove the screw **4** and the card pops up.

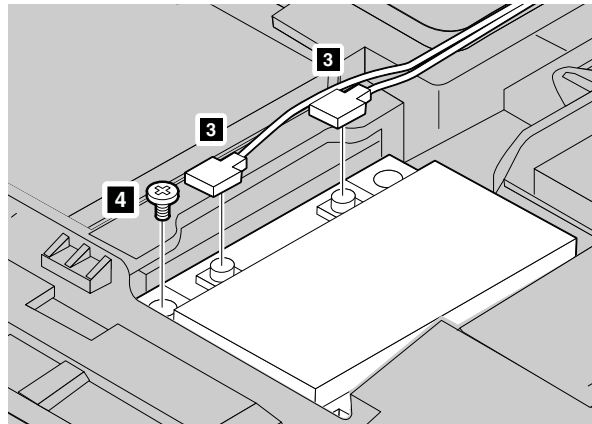

6. Remove the card.



7. Align the contact edge of the new PCI Express Mini Card with the corresponding socket.
8. Pivot the card until you can snap it into place. Then secure the card with the screw.
9. Connect the antenna cables to the new PCI Express Mini Card. Be sure to attach the gray cable to the connector marked “MAIN” or “M” on the card, and the black cable to the connector marked “AUX” or “A”.
10. Reinstall the computer cover, and then reinstall the screws to secure the cover.
11. Reinstall the battery. See “Replacing the battery” on page 33.
12. Turn the computer over again. Connect the ac power adapter and all cables.

Removing the optical drive

Before you start, print these instructions.

Note: Your computer might look different from the illustrations in this topic.

To replace the optical drive, do the following:

1. Turn off the computer; then disconnect the ac power adapter and all cables from the computer. Wait three to five minutes to let the computer cool.
2. Close the computer display, and turn the computer over.
3. Remove the battery. See “Replacing the battery” on page 33.
4. Remove the screws **1**, and then remove the cover **2**.

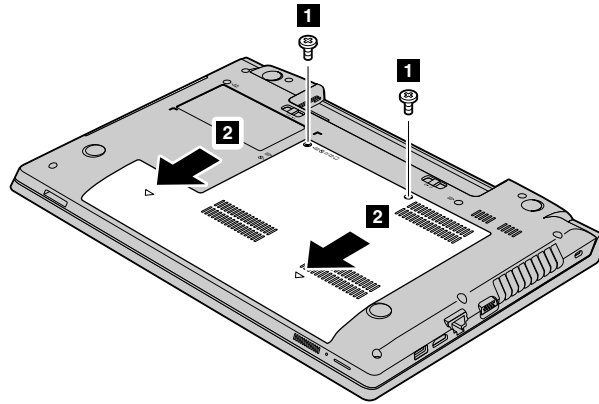

5. Remove the screw **3** that secures the optical drive.

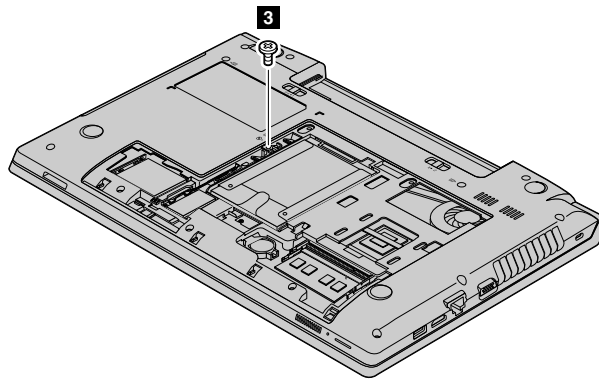

6. Insert a screwdriver into the screw hole, and then push the optical drive **5** to remove it.

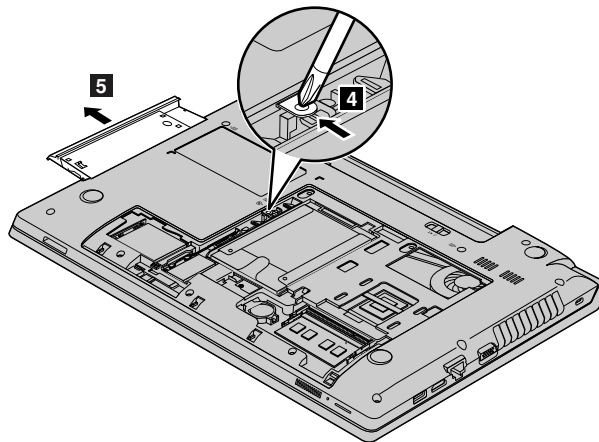

7. Insert a new optical drive, and then reinstall the screw to secure the drive.
8. Reinstall the computer cover, and then reinstall the screws to secure the cover.
9. Reinstall the battery. See “Replacing the battery” on page 33.
10. Turn the computer over again. Connect the ac power adapter and all cables.

Chapter 8. Preventing problems

An important part of owning a Lenovo notebook computer is maintenance. With proper care, you can avoid common problems. The chapter provides information that can help you keep your computer running smoothly.

- “General tips for preventing problems” on page 43
- “Taking care of your computer” on page 44

General tips for preventing problems

1. Check the capacity of your hard disk drive from time to time. If the hard disk drive gets too full, the operating system will slow down and might produce errors.
2. Empty your recycle bin on a regular basis.
3. To free up disk space, uninstall unused application programs.
4. Clean out your Inbox, Sent, and Trash folders from your e-mail client program.
5. Back up your data at least once a week. If critical data is present, it is a good idea to perform a daily backup operation. Lenovo has many backup options available for your computer. CD-RW drives and CD-RW/DVD drives are available for most computers and are easily installed.
6. Schedule system restore operations to take a system snapshot periodically.

Note: Always take a system snapshot before installing new drivers, updating software, or installing new software.

7. Update device drivers and BIOS when needed.
8. Profile your machine at <http://www.lenovo.com/support> to keep up to date with current drivers and revisions.
9. Keep up to date for device drivers on other non-Lenovo hardware. You might want to read the device driver information release notes prior to updating for compatibility or known issues.
10. Keep a log book. Entries might include major hardware or software changes, driver updates, minor issues you have experienced, and how you resolved the minor issues.
11. If required, you can find your country's Customer Support Center at <http://www.lenovo.com/support>. When calling the Customer Support Center, make sure that you have your machine model type, serial number, and the computer in front of you. Also, if the computer is producing error codes, it is helpful to have the error screen on or the message written down.

If you need help, service, technical assistance, or just want more information about Lenovo products, you will find a wide variety of sources available from Lenovo to assist you. This section contains information about where to go for additional information about Lenovo and our products, what to do if you experience a problem with your computer, and whom to call for service should it be necessary.

Information about your computer and preinstalled software, if any, is available in the documentation that comes with your computer. That documentation includes printed books, online books, readme files, and help files. In addition, information about Lenovo products is available on the World Wide Web.

Microsoft® Service Packs are the latest software source for Windows product updates. They are available through Web download (connection charges might apply) or through discs. For more specific information and links, go to <http://www.microsoft.com>. Lenovo offers technical assistance with installation of, or questions related to, Service Packs for your Lenovo-preloaded Microsoft Windows product. For information, contact the Customer Support Center.

Taking care of your computer

Although your computer is designed to function reliably in normal work environments, you need to use common sense in handling it. By following these important tips, you will get the most use and enjoyment out of your computer.

Be careful about where and how you work

- Do not eat or smoke over your keyboard. Particles that fall into your keyboard can cause damage.
- Store packing materials safely out of the reach of children to prevent the risk of suffocation from plastic bags.
- Keep your computer away from magnets, activated cellular phones, electrical appliances, or speakers (within 13 cm or 5 inch).
- Avoid subjecting your computer to extreme temperatures (below 5°C/41°F or above 35°C/95°F).
- Some appliances, such as certain portable desktop fans or air purifiers, can produce negative ions. If a computer is close to such an appliance, and is exposed for an extended time to air containing negative ions, it might become electrostatically charged. Such a charge might be discharged through your hands when you touch the keyboard or other parts of the computer, or through connectors on I/O devices connected to it. Even though this kind of electrostatic discharge (ESD) is the opposite of a discharge from your body or clothing to the computer, it poses the same risk of a computer malfunction.

Your computer is designed and manufactured to minimize any effects of electrostatic charge. An electrostatic charge above a certain limit, however, can increase the risk of ESD. Therefore, when using the computer close to an appliance that can produce negative ions, give special attention to the following:

- Avoid directly exposing your computer to the air from an appliance that can produce negative ions.
- Keep your computer and peripherals as far as possible from such an appliance.
- Wherever possible, ground your computer to facilitate safe electrostatic discharge.

Note: Not all such appliances cause a significant electrostatic charge.

Be gentle with your computer

- Avoid placing any objects (including paper) between the display and the keyboard or the palm rest.
- Do not open the display beyond 130 degrees, as this might damage the computer hinge.
- Do not turn your computer over while the ac power adapter is plugged in. This could break the adapter plug.

Carry your computer properly

- Before moving your computer, be sure to remove any media, turn off attached devices, and disconnect cords and cables.
- Before moving your computer, ensure that it is in sleep or hibernation mode, or turned off. This will prevent damage to the hard disk drive and avoid data loss.
- When picking up your open computer, hold it by the bottom. Do not pick up or hold your computer by the display.
- Use a quality carrying case that provides adequate cushion and protection. Do not pack your computer in a tightly packed suitcase or bag.

For outdoor use

- Back up your critical data before you take your computer outdoors.
- Ensure that the battery is fully charged.

- Be sure to turn off the power and close the LCD when not in use.
- When you leave the computer in your car, place it on the back seat to avoid being insulated.
- Carry the ac power adapter and power cord with the computer.

Handle storage media and drives properly

- If your computer comes with an optical drive, do not touch the surface of a disc or the lens on the tray.
- Wait until you hear the CD or DVD click into the center pivot of the drive before closing the tray.
- When installing the hard disk drives or optical drives, follow the instructions shipped with your hardware, and apply pressure only where needed on the device.
- Turn off your computer if you are replacing the hard disk drive.
- Store your external and removable hard disk drives or optical drives in the appropriate containers or packaging when not in use.
- Before you install any of the following devices, touch a metal table or a grounded metal object. This action reduces any static electricity from your body. The static electricity could damage the device.
 - Memory cards, such as SD cards, Memory Stick cards, MultiMediaCard modules, and Memory Stick Pro cards
 - Memory modules

Note: Not all listed devices are included in your computer.

This action reduces any static electricity from your body. The static electricity could damage the device.

- When transferring data to or from a flash media card, such as an SD card, do not put your computer in sleep or hibernation mode before the data transfer is complete. To do so might cause damage to your data.

Data protection

- Do not delete unknown files or change the name of files or directories that were not created by you; otherwise, your computer software might fail to work.
- Be aware that accessing network resources can leave your computer vulnerable to computer viruses, hackers, spyware, and other malicious activities that might damage your computer, software, or data.
- It is your responsibility to ensure that you have adequate protection in the form of firewalls, antivirus software, and anti-spyware software and keep the software up to date.

Take care in setting passwords

Remember your passwords. If you forget a supervisor or hard disk password, Lenovo authorized service providers will not reset it, and you might have to replace your system board or hard disk drive.

Clean the cover of your computer

Occasionally clean your computer by doing the following:

1. Prepare a mixture of a gentle kitchen-use detergent (one that does not contain abrasive powder or strong chemicals such as acid or alkaline). Use 5 parts water to 1 part detergent.
2. Absorb the diluted detergent into a sponge.
3. Squeeze excess liquid from the sponge.
4. Wipe the cover with the sponge, using a circular motion and taking care not to let any excess liquid drip.
5. Wipe the surface to remove the detergent.
6. Rinse the sponge with clean running water.
7. Wipe the cover with the clean sponge.

8. Wipe the surface again with a dry, soft, lint-free cloth.
9. Wait for the surface to dry completely and remove any fibers from the cloth.

Note: Shut down the computer and then disconnect the power cord before cleaning the computer.

Cleaning your computer keyboard

To clean the computer keyboard, do the following:

1. Apply some isopropyl rubbing alcohol to a soft, dust-free cloth.
2. Wipe each keytop surface with the cloth. Wipe the keys one by one; if you wipe several keys at a time, the cloth might hook onto an adjacent key and possibly damage it. Make sure that no liquid drips onto or between the keys.
3. Allow to dry.
4. To remove any crumbs and dust from beneath the keys, you can use a camera blower with a brush or cool air from a hair drier.

Note: Avoid spraying cleaner directly onto the display or the keyboard.

Cleaning your computer display

To clean your computer display, do the following:

1. Gently wipe the display with a dry, soft, lint-free cloth. If you see a scratchlike mark on your display, it might be a stain transferred from the keyboard when the cover was pressed from the outside.
2. Wipe or dust the stain gently with a soft, dry cloth.
3. If the stain remains, moisten a soft, lint-free cloth with water or a 50-50 mixture of isopropyl alcohol and water that does not contain impurities.
4. Wring out as much of the liquid as you can.
5. Wipe the display again; do not let any liquid drip into the computer.
6. Be sure to dry the display before closing it.

Registering your computer

To register your computer with Lenovo, do either of the following:

- Go to <http://www.lenovo.com/register> and then follow the on-screen instructions to register your computer.
- Connect your computer to the Internet and register your computer through a preinstalled registration program.
 - For the Windows 7 operating system: The preinstalled Lenovo Product Registration program launches automatically after you have used your computer for a time. Follow the on-screen instructions to register your computer.
 - For the Windows 8 operating system: Launch the Lenovo Support program. Then click **Registration** and follow the on-screen instructions to register your computer.

Be sure not to modify your computer

- Only an authorized Lenovo repair technician should disassemble and repair your computer.
- Do not modify or tape the latches to keep the display open or closed.

Chapter 9. Troubleshooting computer problems

This chapter provides information on what to do if you experience a problem with your computer.

Notice for users in U.S.A

- If your product is not working correctly, DO NOT RETURN IT TO THE STORE.
- For technical assistance, contact a Lenovo support specialist 24 hours a day by calling toll free 1-877-4 LENOVO (1-877-453-6686).
- Additionally, you can find support information and updates on the Lenovo Web site located at <http://www.lenovo.com/support>

Troubleshooting

To make sure that your computer has the features that are introduced in the following sections, consult the online help or the list shipped with your computer.

Battery and power problems

This topic contains instructions on troubleshooting battery and power problems.

Battery problems

Print these instructions now and keep it with your computer for reference later.

The battery pack cannot be fully charged in the standard charge time when the computer is powered off.

The battery pack might be over-discharged. Do the following:

1. Turn off the computer.
2. Make sure that the over-discharged battery pack is in the computer.
3. Connect the ac power adapter to the computer and let it charge.

If a quick charger is available, use it to charge the over-discharged battery pack.

If the battery pack cannot be fully charged in 24 hours, use a new battery pack.

Your computer shuts down before the battery status indicator shows empty, or your computer operates after the battery status indicator shows empty.

Discharge and recharge the battery pack.

The operating time for a fully charged battery pack is short.

Discharge and recharge the battery pack. If your battery operating time is still short, use a new battery pack.

The computer does not operate with a fully charged battery pack.

The surge protector in the battery pack might be active. Turn off the computer for one minute to reset the protector; then turn on the computer again.

The battery pack cannot be charged.

You cannot charge the battery when it is too hot. If the battery feels hot, remove it from the computer and allow it to cool to room temperature. After it cools, reinstall it and recharge the battery. If it still cannot be charged, have it serviced.

An ac power adapter problem

Print these instructions now and keep it with your computer for reference later.

The ac power adapter is connected to the computer and the working electrical outlet, but the power adapter (power plug) icon is not displayed on the taskbar. Also the ac power indicator does not light up.

Do the following:

1. Make sure that the connection of the ac power adapter is correct. For instructions on connecting the ac power adapter, see *Safety, Warranty, and Setup Guide* that comes with your computer.
2. If the connection of the ac power adapter is correct, turn off the computer, then disconnect the ac power adapter and remove the main battery.
3. Reinstall the battery and reconnect the ac power adapter, then turn on the computer.
4. If the power adapter icon still is not displayed on the taskbar and the ac power indicator does not light up, have the ac power adapter and your computer serviced.

A startup problem

Print these instructions now and keep it with your computer for reference later.

The Microsoft Windows operating system does not start.

On the Windows operating system, use the recovery program preinstalled on your computer to help solve or identify your problem. For details, refer to the instructions in Chapter 6 “Recovery overview” on page 29.

Sleep and hibernation problems

Print these instructions now and keep it with your computer for reference later.

A critical low-battery error occurs, and the computer immediately turns off.

The battery power is getting low. Connect the ac power adapter to the computer and plug it into an electrical outlet, or replace the battery with a charged one.

The computer enters sleep mode immediately after the power-on self-test.

Make sure that:

- The battery is charged.
- The operating temperature is within the acceptable range. refer to Chapter 8 “Preventing problems” on page 43.

Computer screen problems

Print these instructions now and keep it with your computer for reference later.

The screen is blank.

Do any of the following:

- If you are using the ac power adapter or using the battery, and the battery status indicator is on, press Fn + up arrow to increase the screen brightness.
- If the power indicator is in blinking, press the power button to resume from the sleep mode.

- Press Fn+F2 to confirm whether the LCD screen has been turned off.

If the problem persists, follow the solution to “The screen is unreadable or distorted.” on page 49

The screen is unreadable or distorted.

Make sure that:

- The display device driver is installed correctly.
- The screen resolution and color quality are correctly set.
- The monitor type is correct.

Incorrect characters are displayed on the screen.

Did you install the operating system or application program correctly? If they are installed and configured correctly, have the computer serviced.

When I turn on the computer, nothing is displayed on the screen and the computer does not beep while starting up.

Make sure that:

- The battery is installed correctly.
- The ac power adapter is connected to the computer and the power cord is plugged into a working electrical outlet.
- The computer is turned on. (Press the power button again for confirmation.)

If these items are correctly set, and the screen remains blank, have the computer serviced.

When I turn on the computer, only a white cursor is displayed on a blank screen.

Restore backed-up files to your Windows environment or the entire contents of your hard disk drive to the original factory contents using the preinstalled recovery programs on your computer. If the problem persists, have the computer serviced.

My screen goes blank while the computer is on.

Your screen saver or power management may be enabled. Do one of the following to exit from the screen saver or to resume from sleep or hibernation mode:

- Touch the touch pad.
- Press the Fn key on the keyboard.
- Press the power button.
- Press Fn+F2 to confirm whether the LCD screen has been turned off.

Problems with drives and other storage devices

This section includes hard disk drive problems and optical drive problems.

Hard disk drive problems

Print these instructions now and keep it with your computer for reference later.

The hard disk drive makes a rattling noise intermittently.

The rattling noise might be heard:

- When the hard disk drive begins or finishes getting access to data.
- When you carry the hard disk drive.

- When you carry your computer.

This is a normal characteristic of a hard disk drive and is not a defect.

The hard disk drive does not work.

On the **Startup → Boot** menu of the BIOS, make sure that the hard disk drive is on the **Boot priority order** list. If it is on the **Excluded from boot order** list, it is disabled. Select the entry for it on the list and press the Shift+1 key. This moves the entry to the **Boot priority order** list.

Optical drive problems

Print these instructions now and keep it with your computer for reference later.

You hear a noise from the drive when the CD, DVD, or CD-RW disc is spinning.

If the disc is not correctly loaded on the center pivot of the drive, it might rub against the drive cover and make a noise. Make sure that the disc is loaded correctly in the drive.

The tray does not open even if you press the eject button.

When your computer is not turned on, pressing the eject button does not cause the drive tray to open. Make sure that the computer is turned on and that the drive connector is firmly connected to the computer.

If the tray still does not open, make sure that the computer is running, and insert the end of a straightened paper clip into the emergency eject hole. The tray will open.

OneKey Recovery Pro program problems

Print these instructions now and keep it with your computer for reference later.

Backup cannot be made.

Make sure that:

- You are not using a Windows operating system.
- There is not enough space to store the backup data. You will need to free more hard disk drive space on your system partition (C drive).

Fail to restore system partition to factory default.

The system partition, such as the partition size or the drive capacity of C, has been modified.

A password problem

Print these instructions now and keep it with your computer for reference later.

I forgot my password.

Do any of the following:

- If you forget your user password, you must take your computer to a Lenovo authorized servicer or a marketing representative to have the password changed.
- If you forget your hard disk drive password, a Lenovo authorized servicer cannot reset your password or recover data from the hard disk drive. You must take your computer to a Lenovo authorized servicer or a marketing representative to have the hard disk drive replaced. Proof of purchase is required, and a fee will be charged for parts and service.
- If you forget your supervisor password, a Lenovo authorized servicer cannot reset your password. You must take your computer to a Lenovo authorized servicer or a marketing representative to have the system board replaced. Proof of purchase is required, and a fee will be charged for parts and service.

A sound problem

Print these instructions now and keep it with your computer for reference later.

No sound can be heard from the speaker even when the volume is turned up.

Make sure that:

- The mute function is off.
- The headphone jack is not used.
- Speakers are selected as the playback device.

Other problems

Print these instructions now and keep it with your computer for reference later.

Your computer does not respond.

Do either of the following:

- To turn off your computer, press and hold the power button for 4 seconds or more. If the computer still does not respond, remove the ac power adapter and the battery.
- Your computer might lock when it enters sleep mode during a communication operation. Disable the sleep timer when you are working on the network.

The computer does not start from a device you want.

Do the following:

1. Check the settings under **Startup → Boot** menu of BIOS. Make sure that the **Boot Priority Order** option starts from the device you want.
2. Also make sure that the device from which the computer starts is enabled. Under the **Startup → Boot** menu, make sure that the device is included in the **Boot Priority Order** list.
3. Press F12 when the Lenovo logo appears on the screen while the computer is starting up to select the device you want the computer starts from.

The connected external device does not work.

Make sure that:

- Do not connect or disconnect any external device cables other than USB cables while the computer is turned on; otherwise, you might damage your computer.
- When using a high power consumption external devices such as an external USB optical drive, use external device power adapter. Otherwise, the device may not be recognized, or the system might be turned off.

For more technical support, go to <http://www.lenovo.com/support>

Appendix A. Regulatory information

Wireless related information

Wireless interoperability

The Wireless LAN PCI Express Mini Card is designed to be interoperable with any wireless LAN product that is based on DSSS, CCK, and/or OFDM radio technology, and is compliant to:

- The 802.11b/g Standard, 802.11a/b/g or 802.11n draft 2.0 on Wireless LANs, as defined and approved by the Institute of Electrical and Electronics Engineers.
- The WiFi certification as defined by the Wi-Fi Alliance.

Your Bluetooth card is compliant to Bluetooth Specification 4.0 as defined by the Bluetooth Special Interest Group SIG, it supports the following profiles:

- Advanced Audio Distribution Profile (A2DP)
- Audio/Video Control Transport Protocol (AVCTP)
- Audio/Video Distribution Transport Protocol (AVDTP)
- A/V Remote Control Profile (AVRCP)
- Basic Imaging Profile (BIP)
- Basic Printing Profile (BPP)
- Dial-Up Networking Profile (DUN)
- File Transfer Profile (FTP)
- Generic Access Profile (GAP)
- Generic A/V Distribution Profile (GAVDP)
- Hardcopy Cable Replacement Profile (HCRP)
- Headset Profile (HSP)
- Hands-Free Profile (HFP)
- Human Interface Device Profile (HID)
- Message Access Profile (MAP)
- Object Exchange Protocol (OBEX)
- Object Push Profile (OPP)
- Personal Area Networking Profile (PAN)
- Phone Book Access Profile (PBAP)
- Service Discovery Protocol (SDP)
- Synchronization Profile (SYNC)
- Video Distribution Profile (VDP)
- Generic Attribute Profile (GATT)
- Proximity Profile
- Find Me Profile
- Immediate Alert Profile

- Battery Status Profile

Usage environment and your health

Integrated wireless cards emit radio frequency electromagnetic energy like other radio devices. However, the level of energy emitted is far much less than the electromagnetic energy emitted by wireless devices like for example mobile phones.

Due to the fact that integrated wireless cards operate within the guidelines found in radio frequency safety standards and recommendations, Lenovo believes they are safe for use by consumers. These standards and recommendations reflect the consensus of the scientific community and result from deliberations of panels and committees of scientists who continually review and interpret the extensive research literature.

In some situation or environment, the use of integrated wireless cards may be restricted by the proprietor of the building or responsible representatives of the organization. These situations and areas may for example include:

- Using the integrated wireless cards on board of airplanes, in hospitals or near petrol stations, blasting areas (with electro-explosive devices), medical implants or body-worn electronic medical devices, such as pace makers.
- In any other environment where the risk of interference to other devices or services is perceived or identified as harmful.

If you are uncertain of the policy that applies to the use of wireless devices in a specific organization (such as airport or hospital), you are encouraged to ask for authorization to use integrated wireless cards prior to turning on the computer.

ENERGY STAR model information



ENERGY STAR® is a joint program of the U.S. Environmental Protection Agency and the U.S. Department of Energy aimed at saving money and protecting the environment through energy efficient products and practices.

Lenovo is proud to offer our customers products with the ENERGY STAR qualified designation. Lenovo computers of the following machine type(s), if the ENERGY STAR mark is affixed, have been designed and tested to conform to the ENERGY STAR program requirements for computers.

3756, 3761, 3772, 6274, 20205, 20206, 20207, 20208

By using ENERGY STAR qualified products and taking advantage of the power-management features of your computer, you can help reduce the consumption of electricity. Reduced electrical consumption can contribute to potential financial savings, a cleaner environment, and the reduction of greenhouse gas emissions.

For more information about ENERGY STAR, go to:
<http://www.energystar.gov>

Lenovo encourages you to make efficient use of energy an integral part of your day-to-day operations. To help in this endeavor, Lenovo has preset the following power-management features to take effect when your computer has been inactive for a specified length of time:

Table 1. ENERGY STAR power-management features

Power plan: Energy Saver (settings when plugged into ac power)
<ul style="list-style-type: none"> • Turn off the display: After 10 minutes • Put the computer to sleep: After 25 minutes • Advanced power settings: <ul style="list-style-type: none"> – Turn off hard disk drives: After 20 minutes – Hibernate: After 1 hour

To awaken your computer from Sleep mode, press the Fn key on your keyboard. For more information about these settings, see your Windows Help and Support information system.

Export classification notice

This product is subject to the United States Export Administration Regulations (EAR) and has an Export Classification Control Number (ECCN) of 4A994.b. It can be re-exported except to any of the embargoed countries in the EAR E1 country list.

Electronic emission notices

The following information refers to the following Lenovo products, machine types: 3756, 3761, 3772, 6274, 20205, 20206, 20207, and 20208.

Lenovo B490, B590, B4301, B4302, B4303, B4305, B4306, B4307, B4308, B4309, B4310, B4311, B4312, B4315, B4316, B4317, B4318, B4319, B4320, B4321, B4322, B4323, B4325, B4326, B4327, B4328, B4329, B4330, B4331, B4332, B4333, B4335, B4336, B4337, B4338, B4339, B4360, B4361, B4362, B4363, B4365, B4366, B4367, B4368, B4369, B4370, B4371, B4372, B4375, B4376, B4377, and B4378

Federal Communications Commission (FCC) Declaration of Conformity

This equipment has been tested and found to comply with the limits for a Class B digital device, pursuant to Part 15 of the FCC Rules. These limits are designed to provide reasonable protection against harmful interference in a residential installation. This equipment generates, uses, and can radiate radio frequency energy and, if not installed and used in accordance with the instructions, may cause harmful interference to radio communications. However, there is no guarantee that interference will not occur in a particular installation. If this equipment does cause harmful interference to radio or television reception, which can be determined by turning the equipment off and on, the user is encouraged to try to correct the interference by one or more of the following measures:

- Reorient or relocate the receiving antenna.
- Increase the separation between the equipment and receiver.
- Connect the equipment into an outlet on a circuit different from that to which the receiver is connected.
- Consult an authorized dealer or service representative for help.

Lenovo is not responsible for any radio or television interference caused by using other than specified or recommended cables and connectors or by unauthorized changes or modifications to this equipment. Unauthorized changes or modifications could void the user's authority to operate the equipment.

This device complies with Part 15 of the FCC Rules. Operation is subject to the following two conditions: (1) this device may not cause harmful interference, and (2) this device must accept any interference received, including interference that may cause undesired operation.

Responsible Party:
Lenovo (United States) Incorporated
1009 Think Place - Building One
Morrisville, NC 27560
Phone Number: 919-294-5900



Industry Canada Class B emission compliance statement

This Class B digital apparatus complies with Canadian ICES-003.

Cet appareil numérique de la classe B est conforme à la norme NMB-003 du Canada.

European Union - Compliance to the Electromagnetic Compatibility Directive

This product is in conformity with the protection requirements of EU Council Directive 2004/108/EC on the approximation of the laws of the Member States relating to electromagnetic compatibility. Lenovo cannot accept responsibility for any failure to satisfy the protection requirements resulting from a non-recommended modification of the product, including the installation of option cards from other manufacturers.

This product has been tested and found to comply with the limits for Class B Information Technology Equipment according to European Standard EN 55022. The limits for Class B equipment were derived for typical residential environments to provide reasonable protection against interference with licensed communication devices.

EU contact: Lenovo, Einsteinova 21, 851 01 Bratislava, Slovakia



German Class B compliance statement

Deutschsprachiger EU Hinweis:

Hinweis für Geräte der Klasse B EU-Richtlinie zur Elektromagnetischen Verträglichkeit

Dieses Produkt entspricht den Schutzanforderungen der EU-Richtlinie 2004/108/EG (früher 89/336/EWG) zur Angleichung der Rechtsvorschriften über die elektromagnetische Verträglichkeit in den EU-Mitgliedsstaaten und hält die Grenzwerte der EN 55022 Klasse B ein.

Um dieses sicherzustellen, sind die Geräte wie in den Handbüchern beschrieben zu installieren und zu betreiben. Des Weiteren dürfen auch nur von der Lenovo empfohlene Kabel angeschlossen werden. Lenovo übernimmt keine Verantwortung für die Einhaltung der Schutzanforderungen, wenn das Produkt ohne Zustimmung der Lenovo verändert bzw. wenn Erweiterungskomponenten von Fremdherstellern ohne Empfehlung der Lenovo gesteckt/eingebaut werden.

Deutschland:

Einhaltung des Gesetzes über die elektromagnetische Verträglichkeit von Betriebsmitteln

Dieses Produkt entspricht dem „Gesetz über die elektromagnetische Verträglichkeit von Betriebsmitteln“

EMVG (früher „Gesetz über die elektromagnetische Verträglichkeit von Geräten“). Dies ist die Umsetzung der EU-Richtlinie 2004/108/EG (früher 89/336/EWG) in der Bundesrepublik Deutschland.

Zulassungsbescheinigung laut dem Deutschen Gesetz über die elektromagnetische Verträglichkeit von Betriebsmitteln, EMVG vom 20. Juli 2007 (früher Gesetz über die elektromagnetische Verträglichkeit von Geräten), bzw. der EMV EG Richtlinie 2004/108/EC (früher 89/336/EWG), für Geräte der Klasse B.

Dieses Gerät ist berechtigt, in Übereinstimmung mit dem Deutschen EMVG das EG-Konformitätszeichen - CE - zu führen. Verantwortlich für die Konformitätserklärung nach Paragraf 5 des EMVG ist die Lenovo (Deutschland) GmbH, Gropiusplatz 10, D-70563 Stuttgart.

Informationen in Hinsicht EMVG Paragraf 4 Abs. (1) 4:

Das Gerät erfüllt die Schutzanforderungen nach EN 55024 und EN 55022 Klasse B.

Korea Class B compliance statement

B급 기기 (가정용 방송통신기자재)
이 기기는 가정용(B급) 전자파적합기기로서 주로 가정에서 사용하는 것을 목적으로 하며, 모든 지역에서 사용할 수 있습니다.

Japan VCCI Class B compliance statement

この装置は、クラスB情報技術装置です。この装置は、家庭環境で使用することを目的としていますが、この装置がラジオやテレビジョン受信機に近接して使用されると、受信障害を引き起こすことがあります。

取扱説明書に従って正しい取り扱いをして下さい。

VCCI-B

Japan compliance statement for products which connect to the power mains with rated current less than or equal to 20 A per phase

日本の定格電流が 20A/相 以下の機器に対する高調波電流規制
高調波電流規格 JIS C 61000-3-2 適合品

Lenovo product service information for Taiwan

台灣 Lenovo 產品服務資訊如下：
荷蘭商聯想股份有限公司台灣分公司
台北市信義區信義路五段七號十九樓之一
服務電話：0800-000-702

Appendix B. WEEE and recycling statements

Lenovo encourages owners of information technology equipment to responsibly recycle their equipment when it is no longer needed. Lenovo offers a variety of programs and services to assist equipment owners in recycling their IT products. Information on product recycling offerings can be found on Lenovo's Internet site at <http://www.lenovo.com/recycling>.

China WEEE statement

《废弃电器电子产品回收处理管理条例》提示性说明

联想鼓励拥有联想品牌产品的用户当不再需要此类产品时，遵守国家废弃电器电子产品回收处理相关法律法规，将其交给当地具有国家认可的回收处理资质的厂商进行回收处理。更多回收服务信息，请点击进入<http://support.lenovo.com.cn/activity/551.htm>

Important WEEE Information



The WEEE marking on Lenovo products applies to countries with WEEE and e-waste regulations (for example, European Directive 2002/96/EC, India E-Waste Management & Handling Rules, 2011). Appliances are labeled in accordance with local regulations concerning waste electrical and electronic equipment (WEEE). These regulations determine the framework for the return and recycling of used appliances as applicable within each geography. This label is applied to various products to indicate that the product is not to be thrown away, but rather put in the established collective systems for reclaiming these end of life products.

Users of electrical and electronic equipment (EEE) with the WEEE marking must not dispose of end of life EEE as unsorted municipal waste, but use the collection framework available to them for the return, recycle, and recovery of WEEE and to minimize any potential effects of EEE on the environment and human health due to the presence of hazardous substances. For additional WEEE information go to: <http://www.lenovo.com/recycling>

Japan recycling statements

Collecting and recycling a disused Lenovo computer or monitor

If you are a company employee and need to dispose of a Lenovo computer or monitor that is the property of the company, you must do so in accordance with the Law for Promotion of Effective Utilization of Resources. Computers and monitors are categorized as industrial waste and should be properly disposed of by an industrial waste disposal contractor certified by a local government. In accordance with the Law for Promotion of Effective Utilization of Resources, Lenovo Japan provides, through its PC Collecting and

Recycling Services, for the collecting, reuse, and recycling of disused computers and monitors. For details, visit the Lenovo Web site at: http://www.lenovo.com/services_warranty/jp/ja/recycle/pcrecycle/.

Pursuant to the Law for Promotion of Effective Utilization of Resources, the collecting and recycling of home-used computers and monitors by the manufacturer was begun on October 1, 2003. This service is provided free of charge for home-used computers sold after October 1, 2003. For details, go to http://www.lenovo.com/services_warranty/jp/ja/recycle/personal/.

Disposing of Lenovo computer components

Some Lenovo computer products sold in Japan may have components that contain heavy metals or other environmental sensitive substances. To properly dispose of disused components, such as a printed circuit board or drive, use the methods described above for collecting and recycling a disused computer or monitor.

Disposing of disused lithium batteries from Lenovo computers

A button-shaped lithium battery is installed on the system board of your Lenovo computer to provide power to the computer clock while the computer is off or disconnected from the main power source. If you want to replace it with a new one, contact your place of purchase or ask for a repair service provided by Lenovo. If you have replaced it by yourself and want to dispose of the disused lithium battery, insulate it with vinyl tape, contact your place of purchase, and follow their instructions. If you use a Lenovo computer at home and need to dispose of a lithium battery, you must comply with local ordinances and regulations.

Disposing of a disused battery pack from Lenovo notebook computers

Your Lenovo notebook computer has a lithium ion battery pack or a nickel metal hydride battery pack. If you are a company employee who uses a Lenovo notebook computer and need to dispose of a battery pack, contact the proper person in Lenovo sales, service, or marketing, and follow that person's instructions. You also can refer to the instructions at <http://www.lenovo.com/jp/ja/environment/recycle/battery/>. If you use a Lenovo notebook computer at home and need to dispose of a battery pack, you must comply with local ordinances and regulations. You also can refer to the instructions at <http://www.lenovo.com/jp/ja/environment/recycle/battery/>.

Recycling information for Brazil

Declarações de Reciclagem no Brasil

Descarte de um Produto Lenovo Fora de Uso

Equipamentos elétricos e eletrônicos não devem ser descartados em lixo comum, mas enviados à pontos de coleta, autorizados pelo fabricante do produto para que sejam encaminhados e processados por empresas especializadas no manuseio de resíduos industriais, devidamente certificadas pelos órgãos ambientais, de acordo com a legislação local.

A Lenovo possui um canal específico para auxiliá-lo no descarte desses produtos. Caso você possua um produto Lenovo em situação de descarte, ligue para o nosso SAC ou encaminhe um e-mail para: reciclar@lenovo.com, informando o modelo, número de série e cidade, a fim de enviarmos as instruções para o correto descarte do seu produto Lenovo.

Battery recycling information for the European Union

EU

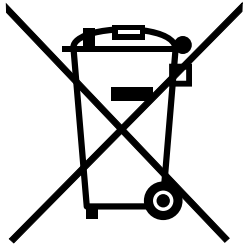

Notice: This mark applies only to countries within the European Union (EU).

Batteries or packaging for batteries are labeled in accordance with European Directive 2006/66/EC concerning batteries and accumulators and waste batteries and accumulators. The Directive determines the framework for the return and recycling of used batteries and accumulators as applicable throughout the European Union. This label is applied to various batteries to indicate that the battery is not to be thrown away, but rather reclaimed upon end of life per this Directive.

In accordance with the European Directive 2006/66/EC, batteries and accumulators are labeled to indicate that they are to be collected separately and recycled at end of life. The label on the battery may also include a chemical symbol for the metal concerned in the battery (Pb for lead, Hg for mercury, and Cd for cadmium). Users of batteries and accumulators must not dispose of batteries and accumulators as unsorted municipal waste, but use the collection framework available to customers for the return, recycling, and treatment of batteries and accumulators. Customer participation is important to minimize any potential effects of batteries and accumulators on the environment and human health due to the potential presence of hazardous substances. For proper collection and treatment, go to:
<http://www.lenovo.com/lenovo/environment>

Battery recycling information for the United States and Canada



US & Canada Only

Battery recycling information for Taiwan



廢電池請回收

Appendix C. Restriction of Hazardous Substances Directive (RoHS)

China RoHS

产品中有毒有害物质或元素的名称及含量

部件名称	有毒有害物质或元素					
	铅(Pb)	汞(Hg)	镉(Cd)	六价铬(Cr(VI))	多溴连苯(PBB)	多溴二苯醚(PBDE)
印刷电路板组件*	X	O	O	O	O	O
硬盘	X	O	O	O	O	O
光驱	X	O	O	O	O	O
内存	X	O	O	O	O	O
电脑I/O 附件	X	O	O	O	O	O
电源	X	O	O	O	O	O
键盘	X	O	O	O	O	O
鼠标	X	O	O	O	O	O
机箱/附件	X	O	O	O	O	O

○:表示该有毒有害物质在该部件所有均质材料中的含量均在SJ/T11363-2006标准规定的限量要求以下
 ×:表示该有毒有害物质至少在该部件的某一均质材料中的含量超出SJ/T11363-2006标准规定的限量要求
 表中标有“×”的所有部件都符合欧盟RoHS 法规。

印刷电路板组件*: 包括印刷电路板及其零部件、电容和连接器
 根据型号的不同,可能不会含有以上的所有部件,请以实际购买机型为准



在中华人民共和国境内销售的电子信息产品必须标识此标志,标志内的数字代表在正常使用状态下的产品的环保使用期限

Turkish RoHS

The Lenovo product meets the requirements of the Republic of Turkey Directive on the Restriction of the Use of Certain Hazardous Substances in Electrical and Electronic Equipment (EEE).

Türkiye EEE Yönetmeliğine Uygunluk Beyanı

Bu Lenovo ürünü, T.C. Çevre ve Orman Bakanlığı'nın "Elektrik ve Elektronik Eşyalarda Bazı Zararlı Maddelerin Kullanımının Sınırlandırılmasına Dair Yönetmelik (EEE)" direktiflerine uygundur.

EEE Yönetmeliğine Uygundur.

Ukraine RoHS

Цим підтверджуємо, що продукція Леново відповідає вимогам нормативних актів України, які обмежують вміст небезпечних речовин

India RoHS

RoHS compliant as per E-Waste (Management & Handling) Rules, 2011.

Appendix D. Notices

Lenovo may not offer the products, services, or features discussed in this document in all countries. Consult your local Lenovo representative for information on the products and services currently available in your area. Any reference to a Lenovo product, program, or service is not intended to state or imply that only that Lenovo product, program, or service may be used. Any functionally equivalent product, program, or service that does not infringe any Lenovo intellectual property right may be used instead. However, it is the user's responsibility to evaluate and verify the operation of any other product, program, or service.

Lenovo may have patents or pending patent applications covering subject matter described in this document. The furnishing of this document does not give you any license to these patents. You can send license inquiries, in writing, to:

*Lenovo (United States), Inc.
1009 Think Place - Building One
Morrisville, NC 27560
U.S.A.
Attention: Lenovo Director of Licensing*

LENOVO PROVIDES THIS PUBLICATION "AS IS" WITHOUT WARRANTY OF ANY KIND, EITHER EXPRESS OR IMPLIED, INCLUDING, BUT NOT LIMITED TO, THE IMPLIED WARRANTIES OF NON-INFRINGEMENT, MERCHANTABILITY OR FITNESS FOR A PARTICULAR PURPOSE. Some jurisdictions do not allow disclaimer of express or implied warranties in certain transactions, therefore, this statement may not apply to you.

This information could include technical inaccuracies or typographical errors. Changes are periodically made to the information herein; these changes will be incorporated in new editions of the publication. Lenovo may make improvements and/or changes in the product(s) and/or the program(s) described in this publication at any time without notice.

The products described in this document are not intended for use in implantation or other life support applications where malfunction may result in injury or death to persons. The information contained in this document does not affect or change Lenovo product specifications or warranties. Nothing in this document shall operate as an express or implied license or indemnity under the intellectual property rights of Lenovo or third parties. All information contained in this document was obtained in specific environments and is presented as an illustration. The result obtained in other operating environments may vary.

Lenovo may use or distribute any of the information you supply in any way it believes appropriate without incurring any obligation to you.

Any references in this publication to non-Lenovo Web sites are provided for convenience only and do not in any manner serve as an endorsement of those Web sites. The materials at those Web sites are not part of the materials for this Lenovo product, and use of those Web sites is at your own risk.

Any performance data contained herein was determined in a controlled environment. Therefore, the result obtained in other operating environments may vary significantly. Some measurements may have been made on development-level systems and there is no guarantee that these measurements will be the same on generally available systems. Furthermore, some measurements may have been estimated through extrapolation. Actual results may vary. Users of this document should verify the applicable data for their specific environment.

Trademarks

The following terms are trademarks of Lenovo in the United States, other countries, or both:

Lenovo
OneKey

The following terms are trademark or registered trademarks of the Microsoft group of companies.

Microsoft
Windows

Other company, products, or service names may be trademarks or service marks of others.

Index

A

ac power adapter 11

B

Built-in microphone 4

C

Camera 1, 17

Charging the battery 12

F

Function key combinations 16

K

Keyboard 14

P

Password 27

S

Security 27

T

Touch pad 2

lenovo®

Part Number:

Printed in China

(1P) P/N:



Free Manuals Download Website

<http://myh66.com>

<http://usermanuals.us>

<http://www.somanuals.com>

<http://www.4manuals.cc>

<http://www.manual-lib.com>

<http://www.404manual.com>

<http://www.luxmanual.com>

<http://aubethermostatmanual.com>

Golf course search by state

<http://golfingnear.com>

Email search by domain

<http://emailbydomain.com>

Auto manuals search

<http://auto.somanuals.com>

TV manuals search

<http://tv.somanuals.com>