

# SEARS

## OWNER'S MANUAL

**MODEL NO.**

390.251182

390.251982

390.252282

**CAUTION:**

Read and Follow  
All Safety Rules and  
Operating Instructions  
Before First Use of  
This Product.

Save This Manual For  
Future Reference.

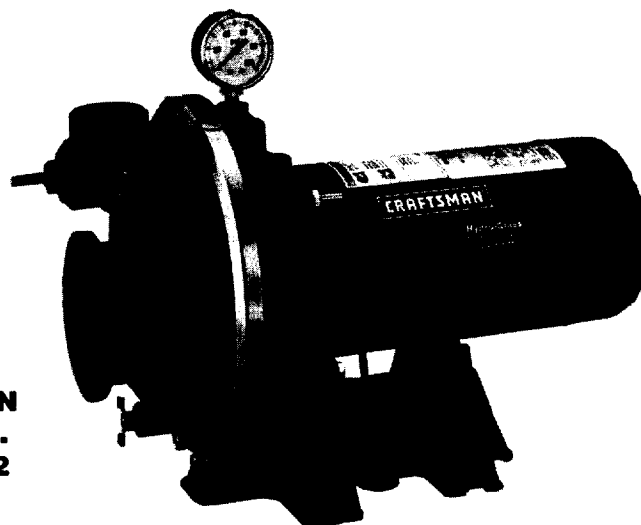

**CRAFTSMAN  
MODEL NO.  
390.251182**

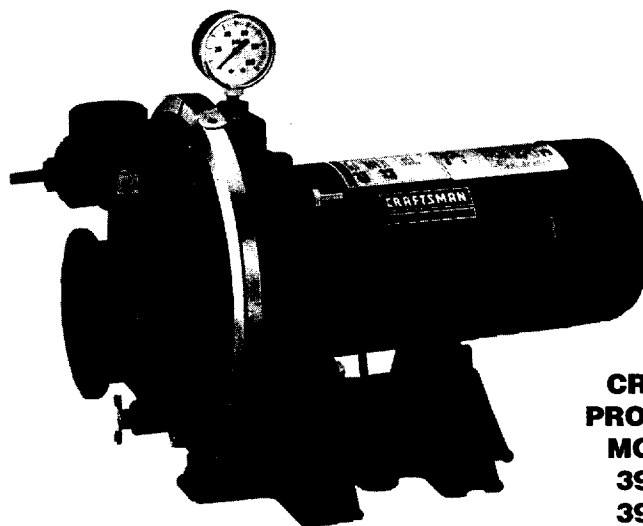

**CRAFTSMAN  
PROFESSIONAL  
MODEL NOS.  
390.251982  
390.252282**

# CRAFTSMAN® “HYDROGLASS”® CONVERTIBLE DEEP WELL JET PUMP

- Safety Instructions
- Installation
- Operation
- Troubleshooting
- Repair Parts

Sears, Roebuck and Co., Hoffman Estates, IL-60179 U.S.A.

# READ AND FOLLOW SAFETY INSTRUCTIONS!



**⚠ DANGER**

**⚠ WARNING**

**⚠ CAUTION**

This is the safety alert symbol. When you see this symbol on your pump or in this manual, look for one of the following signal words and be alert to the potential for personal injury:

**DANGER** warns about hazards that will cause serious personal injury, death or major property damage if ignored.

**WARNING** warns about hazards that will or can cause serious personal injury, death or major property damage if ignored.

**CAUTION** warns about hazards that will or can cause minor personal injury or property damage if ignored.

The label **NOTICE** indicates special instructions which are important but not related to hazards.

**Carefully read and follow all safety instructions in this manual and on pump.**

Keep safety labels in good condition.

Replace missing or damaged safety labels.

## Electrical Safety

## General Safety

**⚠ WARNING**



**Hazardous voltage. Can shock, burn, or cause death.**

Ground pump before connecting to power supply.

**⚠** Wire motor for correct voltage. See "Electrical" section of this manual and motor nameplate.

**⚠** Ground motor before connecting to power supply.

**⚠** Meet National Electrical Code and local codes for all wiring.

**⚠** Follow wiring instructions in this manual when connecting motor to power lines.

Make workshops childproof; use padlocks and master switches; remove starter keys.

## General Safety

Do not allow pump, pressure tank, piping, or any other system component containing water to freeze. Freezing may damage system, leading to injury or flooding. Allowing pump or system components to freeze will void warranty.

**⚠ WARNING**



**Hazardous pressure! Install pressure relief valve in discharge pipe.**

Release all pressure on system before working on any component.

Relief valve must be capable of passing full pump flow at 75 PSI.

Pump water only with this pump.

Periodically inspect pump and system components.

Wear safety glasses at all times when working on pumps.

Keep work area clean, uncluttered and properly lighted; store properly all unused tools and equipment.

Keep visitors at a safe distance from the work areas.

**⚠ WARNING** Pump body may explode if used as a booster pump unless relief valve capable of passing full pump flow at 75 PSI (517 kPa) is installed.

**⚠ CAUTION** Motor normally operates at high temperature and will be too hot to touch. It is protected from heat damage during operation by an automatic internal cutoff switch. Before handling pump or motor, stop motor and allow it to cool for 20 minutes.

## CONTENTS

Safety .....	2
Warranty/Introduction .....	3
Installation .....	4-8
Electrical .....	9
Operation .....	10
Maintenance .....	10
Service .....	11-12
Pump Performance .....	14
Repair Parts .....	15-19

## INTRODUCTION

We suggest you take a few minutes to read the instructions contained in this manual before installing and using your pump. This will help you obtain the full benefits of the quality and convenience built into this equipment. It will also help you avoid any needless service expense resulting from causes beyond our control which naturally cannot be covered in our warranty.

### FULL ONE YEAR WARRANTY ON CRAFTSMAN WELL PUMPS

For one year from the date of purchase Sears will replace or replace this pump if defective in materials or workmanship.

### LIMITED WARRANTY ON CRAFTSMAN PROFESSIONAL HYDROGLASS WELL PUMPS

After one year and through three years from the date of purchase Sears will furnish, free of charge, a replacement part for any defective part. You pay for labor.

### LIMITED WARRANTY ON CRAFTSMAN HYDROGLASS WELL PUMPS

After one year and through two years from the date of purchase. Sears will furnish, free of charge a replacement part for any defective part. You pay for labor.

This warranty does not cover repair or replacement parts necessary because of abuse or neglect including failure to install adjust and operate this pump according to the instructions in the owners manual.

### LIMITATION OF LIABILITY

**SEARS WILL NOT BE LIABLE FOR LOSS OR DAMAGE TO PROPERTY OR ANY INCIDENTAL OR CONSEQUENTIAL LOSS OR EXPENSE FROM PROPERTY DAMAGE DUE DIRECTLY OR INDIRECTLY FROM THE USE OF THIS PRODUCT**

Some states do not allow the exclusion or limitation of incidental or consequential damage so the above limitation or exclusion may not apply to you.

### WARRANTY SERVICE IS AVAILABLE BY SIMPLY CONTACTING THE SEARS SERVICE CENTER/DEPARTMENT IN THE UNITED STATES

This warranty applies only while the product is in use in the United States

This warranty gives you specific legal rights and you also have other rights which vary from state to state.

Sears, Roebuck and Co., Dept. 817WA, Hoffman Estates, IL 60179

## RULES FOR SAFE INSTALLATION AND OPERATION

1. Read the Owners Manual and Rules for Safe Operation and Installation Instructions carefully. Failure to follow these Rules and Instructions could cause serious bodily injury, and/or property damage.
2. Check your local electrical wiring codes before installation. If your local codes are not followed, your pump will not work to its full rated capacity. If in doubt, contact your local Power Company.
3. Be certain your pump installation meets all local plumbing, pump and well codes.
4. While installing the pump, always keep the well covered to prevent leaves and foreign matter from falling into the well and contaminating the water and/or causing possible serious damage to the mechanical operation of the pump.
5. Always test the well water for purity before using. Check with local health department for testing procedure.
6. Before installing or servicing your pump, BE CERTAIN pump power source is disconnected.
7. Be sure your pump electrical circuit is properly grounded.
8. Complete pump and piping system MUST be protected against below freezing temperature. Failure to do so could cause severe damage and voids the Warranty.
9. Make sure the line voltage and frequency of the electrical circuit supply agree with the motor wiring. If motor is dual voltage type, BE SURE it is wired correctly for your power supply.
10. The correct fusing and wiring sizing is essential to proper motor operation. Recommended fusing and wire size data is in the manual.

# INSTALLATION - DEEP WELL

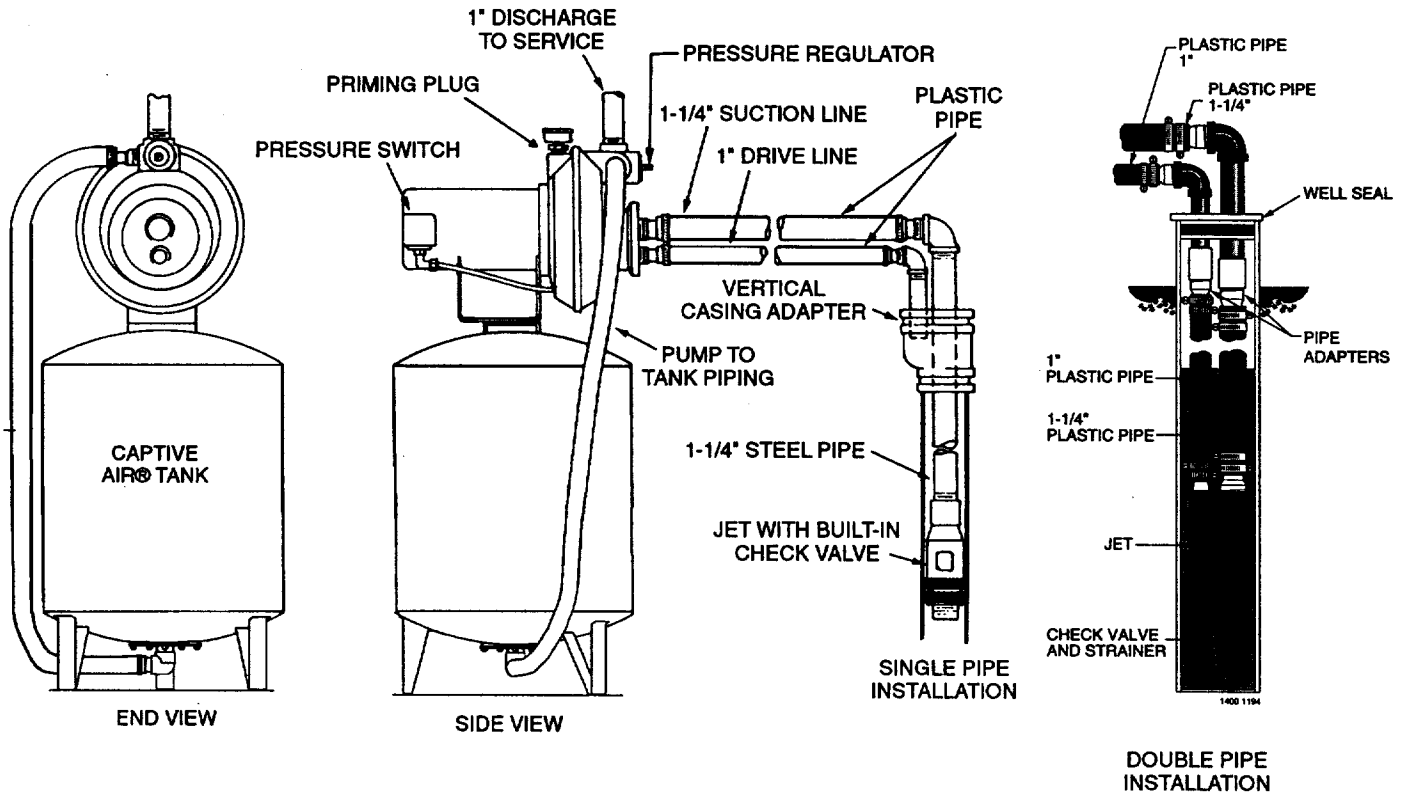

Figure 1 - Captive Air® Pressure Tank Installation - Deep Well

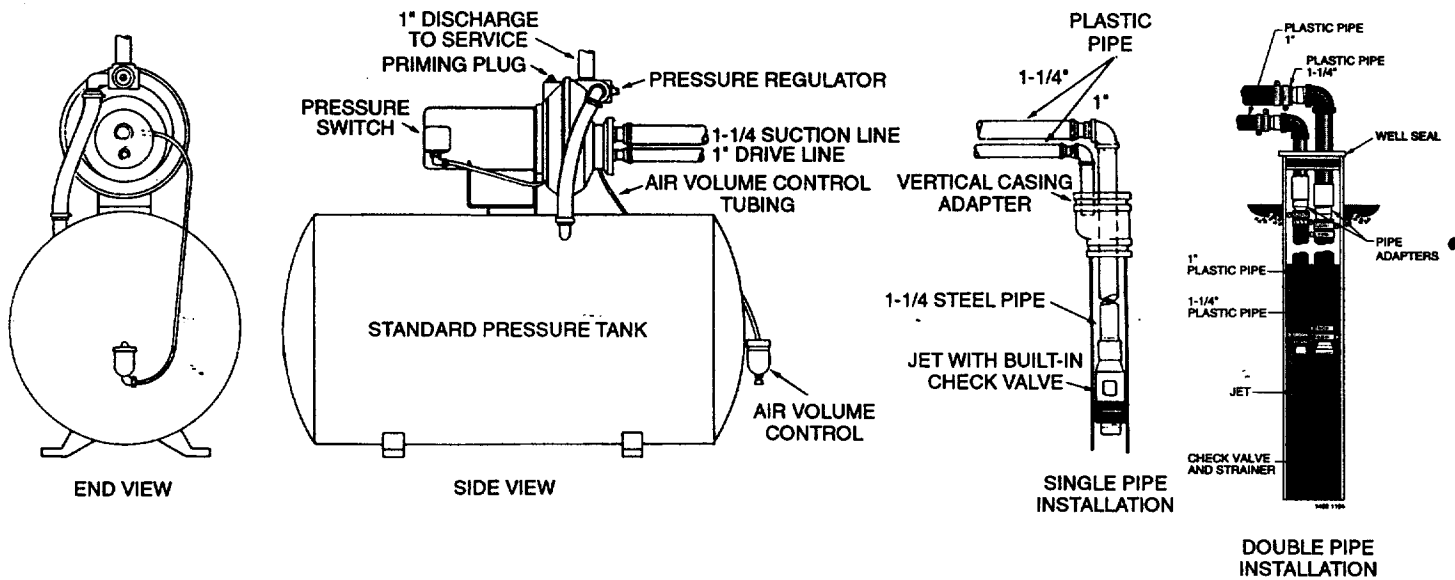
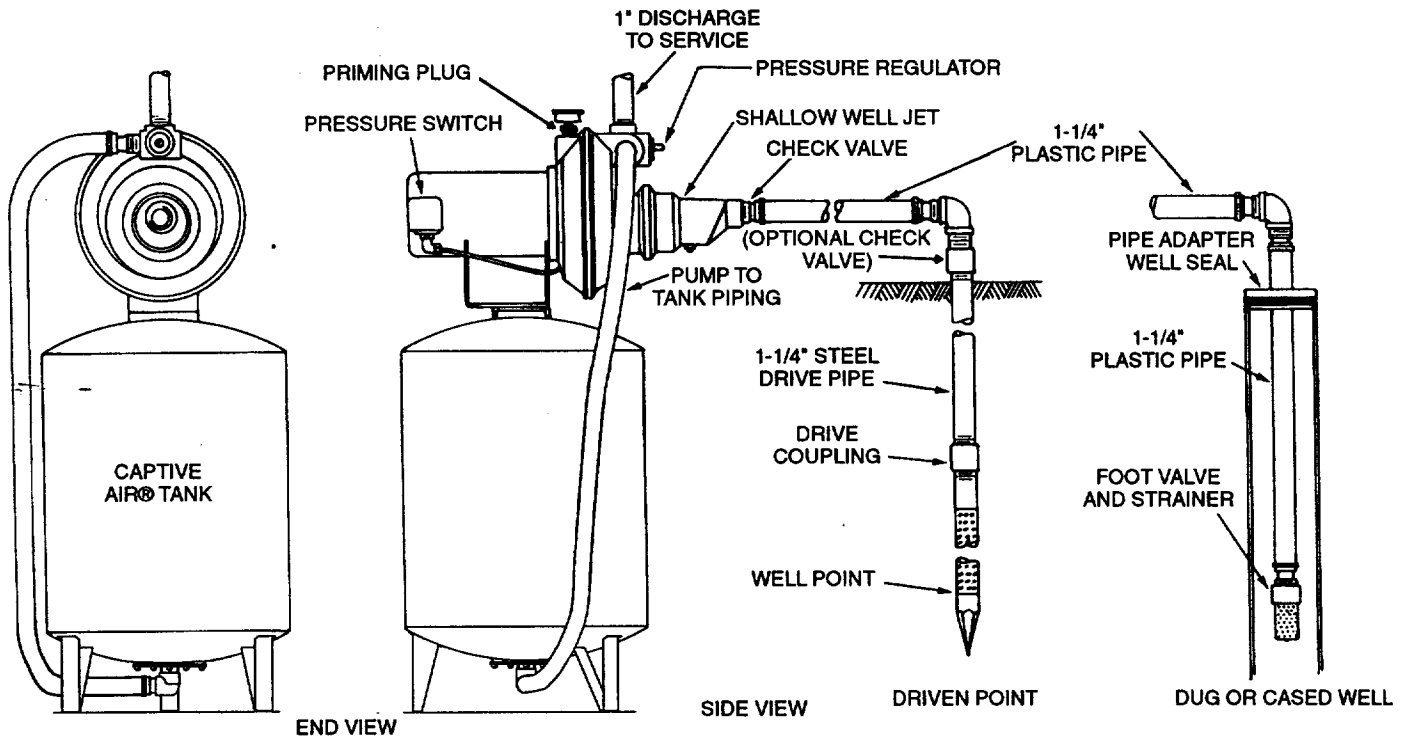
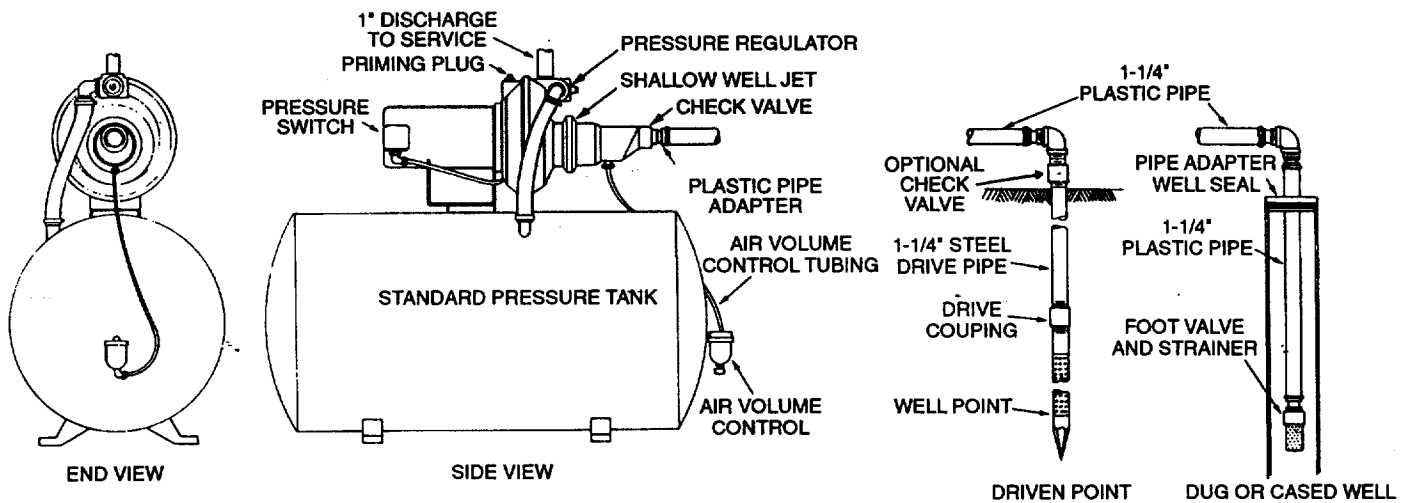

Figure 2 - Standard Pressure Tank Installation - Deep Well

# INSTALLATION - SHALLOW WELL



**Figure 3 – Captive Air® Pressure Tank Installation - Shallow Well**



**Figure 4 – Standard Pressure Tank Installation - Shallow Well**

# INSTALLATION

**NOTICE:** Use Teflon tape supplied with the pump or Plasto-Joint Stik1 for making all pipe-thread connections to the pump itself. To avoid stress-cracking, do not use pipe joint compounds on the pump.

1. Wrap male pipe threads being attached to pump with one or two layers of Teflon tape. Cover entire threaded portion of pipe.
2. Do not overtighten threaded fittings in the plastic pump. Be sure you do not try to tighten joint past thread stop in pump port!
3. If leaks occur, remove fittings, clean off old tape, rewrap with one to two layers of tape and remake the connection. If joint still leaks, replace the fittings (fittings may be undersized).
4. Be sure to support all piping connected to the System.

## MAJOR COMPONENTS AND WHAT THEY DO

### Tank and Air Volume Control

The tank serves two functions. It provides a reservoir of water, some of which can be drawn through the house fixture before the pump must start, and it maintains a cushion of air under pressure.

When Captive Air® Tanks are used, no air volume control is necessary. This tank contains a permanent pre-charge of air.

When a Standard Tank is used, an air volume control adds air to the tank when it is needed. See instructions included with Air Volume Control for details on installation and operation.

### Pressure Switch

The pressure switch provides for automatic operation.

MODEL NO.	PUMP STARTS AT	PUMP STOPS AT
390.251182	30 Pounds	50 Pounds
390.251982	40 Pounds	60 Pounds
390.252282	40 Pounds	60 Pounds

### Impeller, Jet and Pressure Regulator

The impeller of the pump rotates with the motor shaft, causing the water to fly out from its rim by centrifugal force. The rotation of the impeller creates a vacuum which "pulls" in more water. Part of the water is diverted back to the jet where it again passes through the nozzle and venturi - creating additional vacuum to draw in more water and delivering it at high pressure to the impeller.

In a **deep well installation**, the jet assembly is submerged in the well because the vertical distance to the water level exceeds the suction lift of the pump.

Adjustment of the pressure regulator causes the right amount of water to be diverted back to the jet for the most efficient operation.

In a **shallow well installation**, the jet assembly is attached directly to the pump because the vacuum created will pull water to the pump.

The pressure regulator may be used to restrict the flow of water in a shallow well system if the SEARS convertible pump produces more water than the well can produce.

## DEEP WELL PUMP INSTALLATION

### (Figures 1 & 2, Page 4)

In a deep well installation, the jet assembly is submerged in the well because the vertical distance to the water level exceeds the suction lift of the pump. A single pipe system must be used in 2" and 3" wells. A double pipe system must be used in 4" or larger wells.

Follow instructions packed with jet package for proper nozzle and venturi combination for your pumping depth.

## DOUBLE PIPE JET

When a double pipe jet is selected, 2 pipes are used in the well. One is the suction pipe, and the other, the pressure pipe. Plastic pipe is ideal for double pipe installations, due to its light weight and easy installation.

Use 100 pound flexible plastic pipe on horizontal jet pumps.

## TO INSTALL 4" DOUBLE PIPE JET

First, inspect jet to make sure no foreign matter has entered the openings.

Be certain no foreign matter enters pipe openings while installing the unit.

### Plastic Pipe Installations

1. Attach a foot valve (not furnished) to the jet with a short nipple.
2. Before installing, be certain foot valve operates freely.
3. A special plastic pipe adapter is included with the jet which screws into the 1-1/4" suction tapping over the venturi.
4. Assemble a plastic pipe adapter (not furnished) into 1" tapping in the jet body.
5. Use sufficient length of plastic pipe to place the jet 10-15 feet below the lowest drawdown water level. This is the level to which the water in the well will drop while being pumped continuously.
6. Tighten all hose clamps securely. A sanitary well seal is required on top of the well casing. Use steel nipples and elbows or specialized galvanized steel elbows to go through the well seat. Use plastic pipe adapters where special elbows are not used.

<sup>1</sup>Lake Chemical Co., Chicago, Illinois

# INSTALLATION

## STEEL PIPING INSTALLATIONS

When steel pipe is used to install the jet, be sure all pipes are clean and the ends are reamed. Screw both 1-1/4" NPT suction pipe and 1" NPT drive pipe directly into the jet body. The special adapter nipple furnished with the jet is not used on steel pipe installations, and should be discarded. Add sufficient piping, using pipe thread compound on the joints until proper depth is reached.

**NOTICE:** Pipe compound can damage plastic components in pump. Use only Teflon tape or Plasto-Joint Stik1 when connecting pipe to pump.

## SINGLE PIPE JETS - 2" OR 3" WELLS

Before installing jet in well, it is necessary to soften jet leathers by soaking in water for a minimum of one hour.

Single pipe-jets must be installed with steel suction piping in the well. Make sure all pipes are clean and ends are reamed before lowering any piping into the well. Look through pipe to make certain there are no obstructions.

During the process of lowering pipe into the well, always install coupling on top end of pipe and above clamp. This will prevent accidental dropping of pipe into well.

Attach the jet to the first length of suction pipe 1-1/4" (NPT). Use turned couplings (furnished) on 2" wells. Standard couplings may be used for suction piping on 3" wells. Use pipe compound on male threads only.

Tighten each length of pipe as it is lowered into the well. Lower it to proper depth which is 10-15 feet below the drawdown water level. This is the level to which the water will drop while the well is being pumped continuously.

**NOTICE:** Due to normal irregularities in the leather of the cup seals and the inner walls of the drop pipe, 2" packer jets do not form a perfect seal. In a dormant system, water will leak back into well over time and pump will normally start and cycle to maintain system pressure level.

## PRIMING PIPE (OR PIPES) IN WELL

Fill piping in well with water as each length is added, or after piping is complete in well. This serves to double check for leaks in piping and foot valve, and simplifies final priming of pump.

## INSTALLING CASING ADAPTER

Slide adapter on to well casing as far as it will go. Tighten three bolts to seal the adapter to the casing. Place a 1" nipple of proper length in the drive pipe opening in the casing adapter, and tighten top nuts. This will seal the glands on to both suction and drive piping. Add elbows and flexible pipe adapters for horizontal installations.

<sup>1</sup>Lake Chemical Co., Chicago, Illinois.

## SHALLOW WELL INSTALLATION AND OPERATION

### Installing the Pump on a Shallow Well

A shallow well jet is available for use when the SEARS jet pump is installed on wells 20 feet or less to drawdown water level.

Install this jet as follows:

- Loosen the stainless steel clamp until it fits over the flange on the jet body.
- Place O-Ring in circular groove on face of suction-drive line flange. If necessary, use petroleum jelly to hold in place.
- Venturi that protrudes from the jet body must be inserted in top (1-1/4" NPT) tapping. For ease of assembly, lubricate the small O-Ring on the end of the venturi and push the shallow well jet assembly into place.
- Align lugs on jet body with slots in pump.
- Place clamp over the flanges and tighten securely.

For standard tank installations, an air volume control is necessary and is connected to the 1/8" tapping in the jet body. Connect as shown in installation drawing, Figure 4, Page 5.

## PIPING IN THE WELL

A shallow well jet pump can be installed on a dug well, drilled well or with a driven point. SEARS shallow well jet pumps have a built-in check valve. In a dug or cased well, a foot valve and strainer is recommended and should be installed 5 to 10 feet below the lowest level to which the water will drop while the pump is operating (pumping water level). See Figure 4, Page 5. Your well driller can furnish this information. The strainer should not be too close to the bottom, or sediment may clog it. Before installing foot valve, check to see if it works freely.

When using a foot valve, a priming tee and a plug as shown in Figure 7 is recommended.

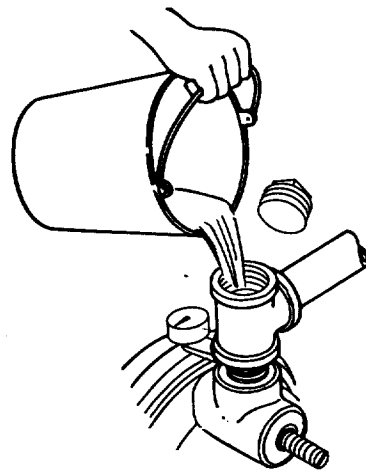

Figure 7

# INSTALLATION

**▲ CAUTION** NEVER run pump dry. Running pump without water may overheat unit, damaging seals and possibly burning persons handling pump.

**▲ WARNING** NEVER run pump against closed discharge. To do so can boil water inside pump, causing hazardous pressure in unit and possible scalding to persons handling pump.

Be sure the total lift from the pumping water level to the pump does not exceed 20 feet if the pump is over the well, or less if the pump is offset from the well. Both figures are for sea level - the maximum lift at which the pump can operate satisfactorily, decreases with the elevation at the approximate rate of 1 foot per 1,000 feet of elevation; thus, if the lift is 17 feet and your elevation is 3,000 feet above sea level, you would then be pumping 17 plus 3 or 20 feet, which is still satisfactory for shallow well pumping.

### Horizontal Piping From Well To Pump

On well point installations where the horizontal piping is more than 25 feet, a check valve should be installed as shown in Figures 3 and 4, Page 5.

When the pump is offset more than 25 feet from the well, horizontal piping should be increased in size to reduced friction losses. In no case should the offset piping be smaller than the suction tapping of the pump.

### Horizontal Offset Piping Sizes

#### Shallow Well Jets

1-1/4"	1-1/2"	2"
Up to 25 Ft.	25 to 50 Ft.	50 to 200 Ft.

### Horizontal Offset Piping Sizes

#### Deep Well Jets

Up to 50 Ft.		50 to 100 Ft.		100 to 300 Ft.	
Suct.	Drive	Suct.	Drive	Suct.	Drive
1-1/4	1	1-1/2	1-1/4	2	1-1/2

### Discharge Pipe Sizes

When the pump is set a distance from the house, barns, or other points of water use, the discharge pipe size should be increased to reduce pressure losses.

1"	1-1/4"	1-1/2"
Up to 25 Ft.	25 to 100 Ft.	100 to 600 Ft.

## PUMP INSTALLATION

SEARS jet pumps can be used with Captive Air® Tanks as shown in Figure 1, Page 4, and Figure 3, Page 5.

For mounting pump to tank, order tank fittings Kit No. 2788.

Captive Air® Tanks are pre-charged with air at the factory. Check operating instructions with tank to determine if air charge needs adjustment.

Model 390.251182 requires 30 pounds air charge for proper operation and Models 390.251982 and 390.252282 require 40 pounds for proper operation.

## EMERGENCY POWER

In some areas and with some installations, an emergency power supply to guard against power failure is a good idea. If you install an engine-generator set for emergency backup power for your pump, supply the generator set manufacturer with the nameplate data from the pump motor. He will then be able to provide a generator of the correct size to power your pump. Also, be sure to add the load from any other accessories (such as lights) that may be on the same circuit.

## Recommended Fusing and Wiring Data

Pump Model	Motor Horsepower	Volts	Max. Load Amperes	Branch* Delayed Fuse Rating Amps	Distance in Feet From Motor to Meter			
					0 to 50	51 to 100	101 to 200	201 to 300
					Wire Size			
390.251182	1/2	115	9.4	15.0	14	14	10	10
		230	4.7	15.0	14	14	14	14
390.251982	3/4	115	12.2	15.0	12	12	10	8
		230	6.1	15.0	14	14	14	14
390.252282	1	115	14.8	20.0	12	12	8	6
		230	7.4	15.0	14	14	14	14

\* Time delayed fuses are recommended instead of fuses in any motor circuit.



# ELECTRICAL

**⚠ Disconnect power before working on pump, motor, pressure switch, or wiring.**

Your Motor Terminal Board (under the motor end cover) and Pressure Switch look like one of those shown below. Convert to 115 Volts as shown. Do not change motor wiring

if line voltage is 230 Volts or if you have a single voltage motor. Connect power supply as shown for your type of switch and your supply voltage.

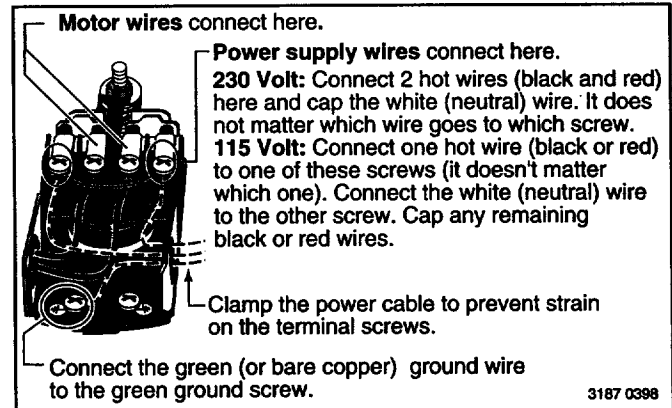
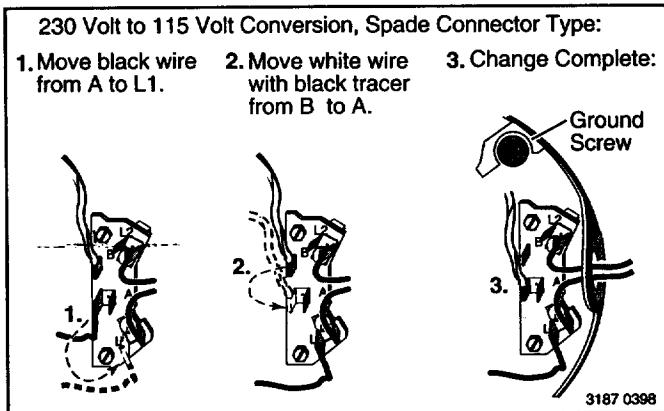
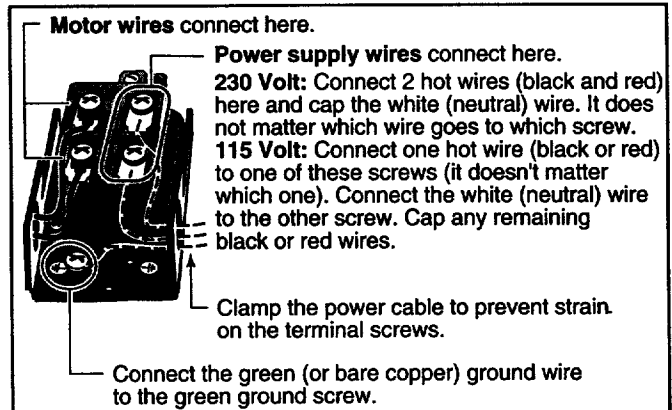
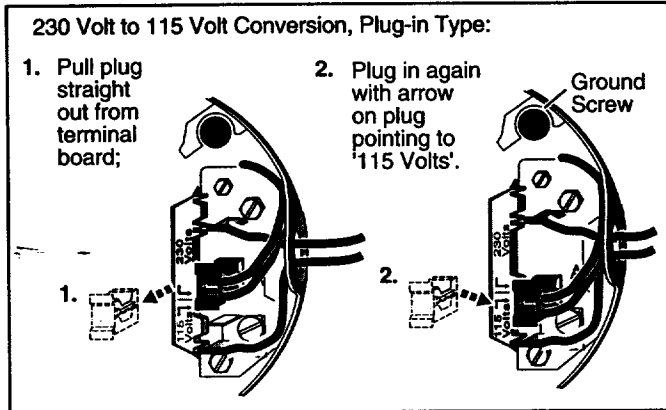

**Figure 8 – Motor wiring connections through Pressure Switch. Match motor voltage to line voltage.**

**⚠ WARNING Hazardous voltage. Can shock, burn, or kill. Connect ground wire before connecting power supply wires. Use the wire size (including the ground wire) specified in the wiring chart. If possible, connect the pump to a separate branch circuit with no other appliances on it.**

**⚠ WARNING Explosion hazard. Do not ground to a gas supply line.**

## Wiring Connections

**⚠ WARNING Fire hazard. Incorrect voltage can cause a fire or seriously damage the motor and voids the warranty. The supply voltage must be within  $\pm 10\%$  of the motor nameplate voltage.**

**NOTICE:** Dual-voltage motors are factory wired for 230 volts. If necessary, reconnect the motor for 115 volts, as shown. Do not alter the wiring in single voltage motors.

Install, ground, wire, and maintain your pump in compliance with the National Electrical Code (NEC) or the Canadian Electrical Code (CEC), as applicable, and

with all local codes and ordinances that apply. Consult your local building inspector for code information.

## Connection Procedure

1. Connect the ground wire first as shown in Figure 8. The ground wire must be a solid copper wire at least as large as the power supply wires.
2. There must be a solid metal connection between the pressure switch and the motor for motor grounding protection. If the pressure switch is not connected to the motor, connect the green ground screw in the switch to the green ground screw under the motor end cover. Use a solid copper wire at least as large as the power supply wires.
3. Connect the ground wire to a grounded lead in a service panel, to a metal underground water pipe, to a metal well casing at least ten feet (3M) long, or to a ground electrode provided by the power company or the hydro authority.
4. Connect the power supply wires to the pressure switch as shown in Figure 8.

## OPERATION

### PRIMING THE SHALLOW WELL PUMP

TO PREVENT DAMAGE TO INTERNAL PARTS, DO NOT START MOTOR UNTIL PUMP HAS BEEN FILLED WITH WATER.

1. Be sure pressure regulator located on pump body is open at all times during priming and running. Turn counter-clockwise all the way.
2. Remove priming plug. Fill pump with water. Replace priming plug. If a priming tee and plug have been provided for a long horizontal run, be sure this line is filled and the plug replaced, using pipe compound on plug threads. See Figure 7, Page 7.
3. Start the pump and run for approximately thirty (30) seconds. Stop pump, remove prime plug and refill with water. Replace prime plug and gauge and restart pump. Water will be pumped in a few minutes, the time depending on the depth to water and length of horizontal run. If pump does not prime, check for a possible leak on the suction side of pump. Check to be sure suction lift - distance from water level to pump - does not exceed twenty (20) feet.

### PRIMING THE DEEP WELL PUMP

TO PREVENT DAMAGE TO INTERNAL PARTS, DO NOT START MOTOR UNTIL PUMP HAS BEEN FILLED WITH WATER.

1. Remove the priming plug. Open pressure regulator (turn counter-clockwise) located on the pump body. Fill pump and piping with water and replace plug and tighten only until it seals.

**NOTICE:** For location of pressure regulator, see Installation Diagrams on Pages 4 and 5.

2. Close the pressure regulator (turn clockwise).
3. Open several faucets in the house or near the tank to prevent pressure build up in tank.
4. Start pump. Pressure should build up rapidly as the jet and pump prime. Pressure will be in excess of 60 pounds. If this fails to happen, repeat 2 and 3 above.
5. Once unit has primed on pressure has stabilized, slowly open (turn counter-clockwise) the pressure regulator and water will begin to be pumped into tank.
6. Continue to open pressure regulator until pressure falters (becomes erratic). At this point, close (turn clockwise) the pressure regulator slightly until pressure stabilizes. Close faucets and allow pump to pressurize the tank and shut off.
7. To insure pump is operating properly, alternately open and close faucets in system. With faucets open, pressure will drop until pressure switch starts pump; and with faucets closed, pressure will build up until pressure switch shuts off pump.
8. There are certain conditions of deep well operation whereby the pressure regulator can be completely open without any faltering of pressure and if so, pump should be operated in this manner.

## MAINTENANCE

### LUBRICATION

It is not necessary to lubricate the pump or its motor. The motor has two ball bearings lubricated for life. The mechanical shaft seal in the pump is water lubricated and self-adjusting.

### DRAINING FOR WINTER

When the pump is to be disconnected from service, or is in danger of freezing, it should be drained. The pump has a drain cock which must be opened. Remove the priming plug to vent the pump. Drain the pressure tank. Drain all piping to a point below the freeze line.

To drain an air volume control, remove AVC tubing and turn (loosen) it 180° on the 1/4" pipe fitting in the tank. This will permit any water remaining in the air volume control to drain back into the tank.

### DISASSEMBLY AND ASSEMBLY OF PUMP

The SEARS Hydroglass® pump is designed for ease in servicing and maintenance.

#### 1. Disassemble pump as follows:

- A. Disconnect power.
- B. Drain pump by opening drain cock on bottom of pump body and remove pressure switch tubing from fitting on top of pump body. This will allow air to replace the water in the pump.
- C. Remove clamp, Key No. 11, Page 16, which holds the two pump halves together.
- D. Remove pump base mounting bolts. Motor assembly and back half of pump can now be pulled away from pump front half. Carefully remove O-Ring and place in a clean area. Inside of pump is now accessible for service.

#### 2. Reassembly of pump.

- A. With a clean cloth, wipe out all foreign material from the large O-Ring groove on the pump back half. Also wipe clean the large O-Ring and also the small O-Ring, Key No. 6, Page 16 on the diffuser, Key No. 10, Page 16. This will insure a good tight seal.
- B. Lubricate O-Rings with petroleum jelly for ease of assembly. Place large O-Ring in groove.
- C. Pump halves can now be slid together until they are parallel and are as close together as possible.
- D. BE SURE inside of clamp is clean. Place clamp on pump halves and snug up. Alternately tighten clamp screw and tap around outside of clamp with a plastic mallet. This will insure proper seating of O-Ring and clamp.
- E. Assemble base mounting bolts. Reconnect pressure switch tubing and tighten drain cock.
- F. Reprime pump and turn on power.

# SERVICE

## REMOVING MOTOR FOR SERVICE AND REPLACING SHAFT SEAL

Should repair or replacement of motor or seal be necessary, the pump need not be disconnected from the piping.

(If it is necessary to repair or replace the motor, ALWAYS replace the shaft seal, Key No. 7, Page 16. Therefore, we suggest that you order this item and have on hand for future use).

### Remove motor as follows:

1. Disassemble pump per disassembly instruction on Page 10.
2. Remove diffuser and impeller, Key Nos. 8 and 9, Page 16, from pump back half.

### Remove Impeller as follows:

1. Loosen two-machine screws and remove the motor canopy, Key No. 1A, Page 16.
2. Partially unscrew capacitor clamp and move capacitor to one side.
3. Place a 7/16" open end wrench on the motor shaft flat.
4. To remove, turn the impeller counterclockwise (when facing impeller).

The seal consists of two parts, a rotating member and a floating seat.

**NOTICE:** The highly polished and lapped faces of the seal are easily damaged. Read instructions carefully.

5. Remove pump back half from motor by unscrewing four (4) nuts, Key No. 20, Page 16, and pry back half off of motor by inserting two (2) screwdrivers between the back pump half and the motor flange. Rotating portion of seal will now come off of shaft. Motor is now separated from pump (see Figure 9).

6. Lay back half of pump (large surface down) on a flat clean surface and tap out ceramic seat. Clean seal cavity from which seal was removed and clean motor shaft.

### Install New Seal As Follows:

1. Clean polished surface of floating seat with clean cloth.
2. Wet the outer edge of the O-Ring on the stationary seat with soap solution.
3. Press seat into cavity firmly and squarely with finger pressure. (Make sure polished face of seal is facing towards inside of pump). If seat will not locate properly, place a cardboard washer over polished face of seat and use piece of 3/4" standard pipe for pressing purposes (see Figure 11).
4. Dispose of cardboard washer and make sure that polished surface of seat is free of dirt or foreign particles and has not been scratched or damaged during installation.
5. Inspect shaft to make sure that it is clean.
6. Reassemble back half of pump to motor.
7. Apply soap solution to inside diameter and outer face of rubber drive ring.

8. Slide seal assembly on shaft (sealing face first) until rubber drive ring hits shaft shoulder. BE SURE you don't chip or scratch sealing face on shaft shoulder.
9. Screw impeller on shaft until impeller hub hits shaft shoulder. This will automatically locate seal in place and move the sealing washer face up against floating seat face (see Figure 11).

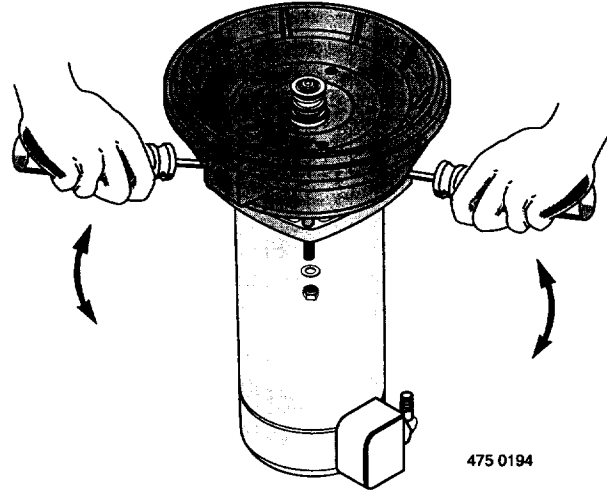

Figure 9

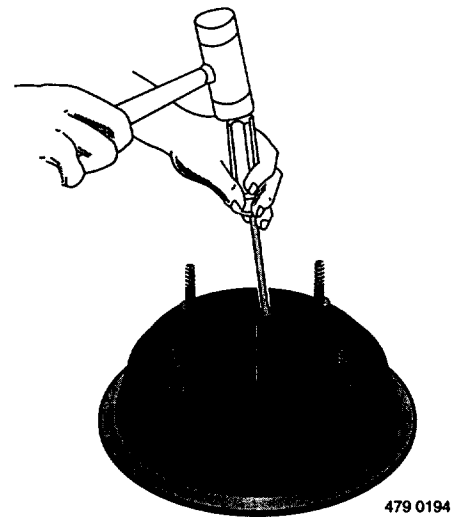

Figure 10

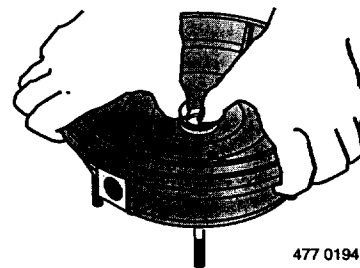

Figure 11

## SERVICE

### CLEANING IMPELLER

1. Disassemble pump per disassembly instruction on Page 10.
2. Remove diffuser and impeller from pump.
3. Clean impeller and reassemble.

### CLEANING SHALLOW WELL JET

To remove a stone or other foreign matter from venturi or nozzle, proceed as follows:

1. Disconnect power, and release all pressure on system.
2. If pump has an air volume control, unscrew compression nut from fitting in lower portion of jet body. Tube will not pull out of fitting.
3. Remove suction piping from pump.
4. Remove stainless steel clamp and remove the jet assembly by pulling it STRAIGHT out and away from the pump body.
5. Turn venturi counter-clockwise and remove it. The nozzle is now exposed and should also be removed by using a 5/8" Hex socket wrench with extension. Turn counter-clockwise. If socket wrench is not available, insert an ice pick, or other similar pointed tool carefully into the nozzle. This will dislodge foreign material.
6. Flush foreign material out by running water through the nozzle in the same direction as the dislodging tool was inserted. Jet body should be in a horizontal position for flushing.
7. Replace nozzle and venturi.
8. Replace jet assembly as explained under "Installing the pump on a shallow well," Page 7.

### CLEANING DEEP WELL JET

1. Disconnect power.
2. Disconnect piping and well seal or well casing adapter. (If pitless adapter is used, piping does not have to be disconnected).
3. Withdraw jet assembly from well.
4. Unscrew and remove the venturi. Remove nozzle with a socket wrench, if possible, and clean. If nozzle cannot be removed, clean as explained in steps 5, 6, and 7 under Cleaning Shallow Well Jet section above.

### HOW TO AVOID OVER-PUMPING A SHALLOW WELL

In the section on **Priming The Shallow Well Pump**, Page 10, the instructions were to open the pressure regulator all the way after the pump starts to deliver water. If you are over-pumping your well, however, you can partially close the pressure regulator on your SEARS jet pump to increase the pressure and reduce the delivery.

### HOW TO HANDLE A GASEOUS WELL

In some localities well water contains gases which must be allowed to escape before the water is used. This can be done as shown in Figure 12.

A good way of delivering gas-free water is to suspend a pipe, closed at the bottom and open at the top, surrounding the suction pipe (Figure 12). Since the gases rise in the well casing, the water sucked down through the pipe and into the suction pipe is free of gas. It is imperative that this type of well be vented to the outside of any enclosure.

### AIR CONTROL IN FLOWING WELLS

Flowing wells, or wells with little or no drawdown, could create a special problem in air control in the operation of your water system.

In such cases, it is recommended that you install a Captive Air® Tank, in which an air control mechanism is not required.

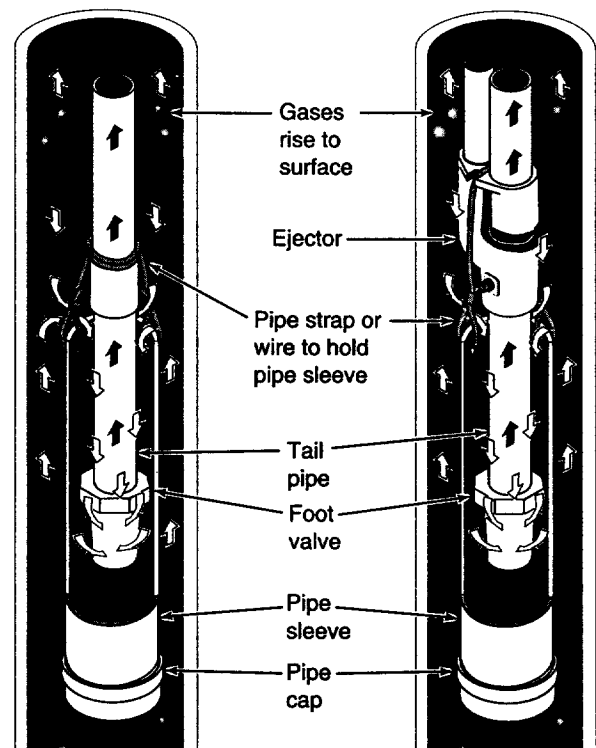

Figure 12

# TROUBLESHOOTING CHART

SYMPTOM	POSSIBLE CAUSE(S)	CORRECTIVE ACTION
Motor will not run	<ol style="list-style-type: none"> <li>1. Disconnect switch is off</li> <li>2. Fuse is blown</li> <li>3. Starting switch is defective</li> <li>4. Wires at motor are loose, disconnected, or wired incorrectly</li> <li>5. Pressure switch contacts are dirty</li> </ol>	<ol style="list-style-type: none"> <li>1. Be sure switch is on</li> <li>2. Replace fuse</li> <li>3. Replace starting switch</li> <li>4. Refer to instructions on wiring. Check and tighten all wiring.</li> <li>5. Clean by sliding pieces of plain paper between contacts</li> </ol>
Motor runs hot and overload kicks off	<ol style="list-style-type: none"> <li>1. Motor is wired incorrectly</li> <li>2. Voltage is too low</li> <li>3. Pump cycles too frequently</li> </ol>	<ol style="list-style-type: none"> <li>1. Refer to instructions on wiring</li> <li>2. Check with power company. Install heavier wiring if wire size is too small. See wiring instructions</li> <li>3. See section below on too frequent cycling</li> </ol>
Motor runs but no water is delivered	<ol style="list-style-type: none"> <li>1. Pump in new installation did not pick up prime through:               <ol style="list-style-type: none"> <li>a. Improper priming</li> <li>b. Air leaks</li> <li>c. Leaking foot valve</li> </ol> </li> <li>2. Pump has lost prime through:               <ol style="list-style-type: none"> <li>a. Air leaks</li> <li>b. Water level below suction of pump</li> </ol> </li> <li>3. Jet or impeller is plugged</li> <li>4. Check valve or foot valve is stuck in closed position</li> <li>5. Pipes are frozen</li> <li>6. Foot valve and/or strainer are buried in sand or mud</li> </ol>	<ol style="list-style-type: none"> <li>1. In new installation:               <ol style="list-style-type: none"> <li>a. Re-prime according to instructions</li> <li>b. Check all connections on suction line, air volume control, and jet</li> <li>c. Replace foot valve</li> </ol> </li> <li>2. In installation already in use:               <ol style="list-style-type: none"> <li>a. Check all connections on suction line, air volume control, jet and shaft seal</li> <li>b. Lower suction line into water and re-prime. If receding water level in well exceeds suction lift, a deep well pump is needed</li> </ol> </li> <li>3. Clean jet or impeller according to instructions</li> <li>4. Replace check valve or foot valve</li> <li>5. Thaw pipes. Bury pipes below frost line. Heat pit or pump house.</li> <li>6. Raise foot valve and/or strainer above well bottom</li> </ol>
Pump does not deliver water to full capacity (Also check point 3 immediately above)	<ol style="list-style-type: none"> <li>1. Water level in well is lower than estimated</li> <li>2. Steel piping (if used) is corroded or limed, causing excess friction</li> <li>3. Offset piping is too small in size</li> </ol>	<ol style="list-style-type: none"> <li>1. A deep well jet pump may be needed (over 20 ft. to water)</li> <li>2. Replace with plastic pipe where possible, otherwise with new steel pipe</li> <li>3. Use larger offset piping</li> </ol>
Pump pumps water but does not shut off	<ol style="list-style-type: none"> <li>1. Pressure switch is out of adjustment or contacts are "frozen"</li> <li>2. Faucets have been left open</li> <li>3. Jet or impeller is clogged</li> <li>4. Water level in well is lower than estimated</li> <li>5. Motor is wired incorrectly</li> </ol>	<ol style="list-style-type: none"> <li>1. Adjust or replace pressure switch</li> <li>2. Close faucets</li> <li>3. Clean jet or impeller</li> <li>4. Check possibility of using a deep well jet pump</li> <li>5. Refer to instructions on wiring</li> </ol>
Pump cycles too frequently	<ol style="list-style-type: none"> <li>1. Standard pressure tank is water-logged and has no air cushion</li> <li>2. Pipe leak</li> <li>3. Faucets or valves are open</li> <li>4. Foot valve leaks</li> <li>5. Pressure switch is out of adjustment</li> <li>6. Air charge too low in Captive Air® Tank <b>Model 390.251182 requires 30 pounds and Models 390.251982 and 390.252282 require 40 pounds for proper operation</b></li> </ol>	<ol style="list-style-type: none"> <li>1. Drain tank to air volume control tapping. Check air volume control for defects. Check for air leaks at any connection</li> <li>2. Check connections</li> <li>3. Close faucets or valves</li> <li>4. Replace foot valve</li> <li>5. Replace pressure switch</li> <li>6. Disconnect electrical power and open faucets until all pressure is relieved. Using automobile tire pressure gauge, check air pressure in tank at the valve stem located at top of tank. If air pressure is lower, pump air into tank from outside source until proper air pressure is reached. Check air valve for leaks, using soapy solution, and replace core if necessary.</li> </ol>
Air spurts from faucets	<ol style="list-style-type: none"> <li>1. Pump is picking up prime</li> <li>2. Leak in suction side of pump</li> <li>3. Well is gaseous</li> <li>4. Intermittent over-pumping of well</li> </ol>	<ol style="list-style-type: none"> <li>1. As soon as pump picks up prime, all air will be ejected</li> <li>2. Check suction piping</li> <li>3. Change installation as described in manual</li> <li>4. Lower foot valve if possible, otherwise restrict discharge side of pump</li> </ol>

*Continued on Page 14*

## TROUBLESHOOTING CHART

SYMPTOM	POSSIBLE CAUSE(S)	CORRECTIVE ACTION
Leaks at the metal clamps <b>⚠ WARNING</b> Release all pressure in system before working on clamp!	1. Loose clamps or O-Ring not sealed	1. First check the clamp tightening screw to see if it is tight. If it is tight and slight leakage still occurs, place a piece of wood on the clamp and firmly tap the wood with a hammer. Repeat this operation around the edge of the clamp and retighten the clamp screw. If leak continues, disassemble clamp and pump halves and check to see that O-Ring is properly seated and no foreign material is on O-Ring or O seat. Reassemble pump.

### Pump Performance at 40 PSI Discharge Pressure

(In Gallons Per Minute)

Type of System	Jet Pkg. Stock No.	Pump Model No.	HP	Pumping Depth in Feet										
				5	10	15	20	30	40	50	60	70	80	90
Shallow Well	29650	390.251182	1/2	8.2	7.3	6.2	5.0							
		390.251982	3/4	10.9	10.4	8.6	7.5							
		390.252282	1	17.0	15.0	13.0	10.5							
2" Single Pipe	29670*	390.251182	1/2					3.4	2.8	2.3	1.8	1.3		
		390.251982	3/4					4.1	3.7	3.1	2.6	2.1	1.6	
		390.252282	1					5.0	4.5	4.1	3.7	3.1	2.6	2.1
3" Single Pipe	29902**†	390.251182	1/2					4.1	3.2	2.0	1.2			
		390.251982	3/4					6.6	5.4	4.4	3.4	2.5	1.9	1.6
		390.252282	1					8.2	7.2	6.2	5.0	3.2	2.7	2.2
4" Double Pipe	29660***	390.251182	1/2					4.1	3.2	2.0	1.2			
		390.251982	3/4					6.6	5.4	4.4	3.4	2.5	1.9	1.6
		390.252282	1					8.2	7.2	6.2	5.0	3.2	2.7	2.2

Use 160 PSI Min. Rating Plastic Pipe.

\* Jet Package No. 29670 – 2" Single Pipe (use 1-1/4" galvanized pipe).

\*\* Jet Package No. 29902 – 3" Single Pipe (use 1-1/4" galvanized pipe).

\*\*\* Jet Package No. 29660 – 4" Double Pipe.

† Must be ordered through Sears Product Service, 1-800-366-7278.

# SHALLOW WELL JET AND CHECK VALVE ASSEMBLY

STOCK NO. 29650

For Pump Models 390.251182, 390.251982 and 390.252282

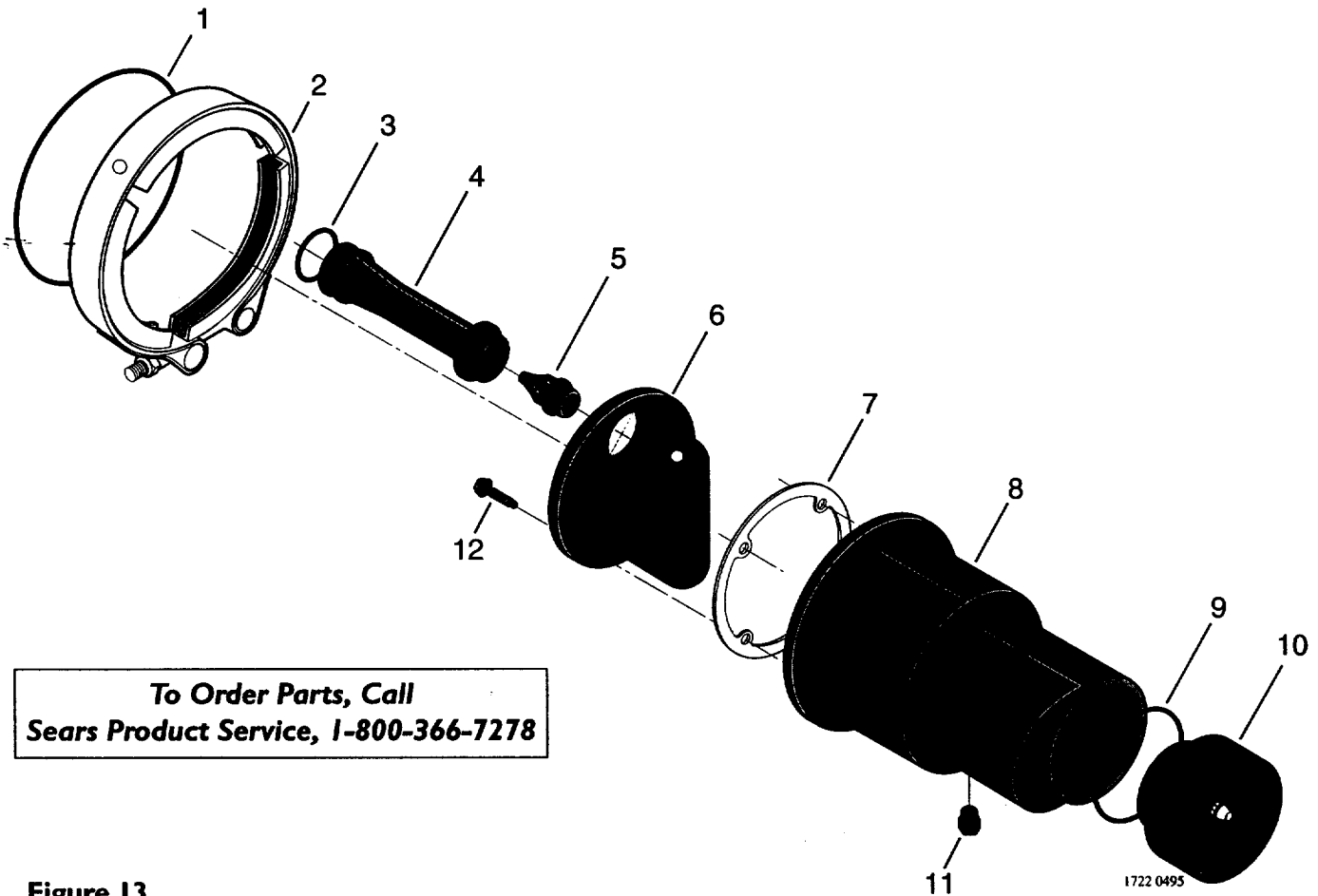

To Order Parts, Call  
Sears Product Service, 1-800-366-7278

Figure 13

## Repair Parts

Key No.	Part Number	Part Description
1	U9-202	O-Ring - Jet Body
2	J19-6	Clamp
3	U9-201	O-Ring - Venturi
4	N32P-63	Venturi (Use with Model 390.252282)
4	N32P-72E	Venturi (Use with Model 390.251982)
4	N32P-72	Venturi (Use with Model 390.251182)
5	J34P-41	#51 Nozzle (Use with Model 390.251182, 390.252282)
5	J34P-44	#54 Nozzle (Use with Model 390.251982)
6	N40-39P	Insert - Jet Body
7	J20-18	Gasket
8	N40-38P	Jet Body
9	U9-226	O-Ring - Check Valve
10	N166-5P	Check Valve - (Complete)
11	WC78-41T	Pipe Plug - 1/8" NPT - Sq. Hd.
12	U30-742SS	Screw - #10 - 16 x 1-1/8" Lg. (4 Req.)

# REPAIR PARTS

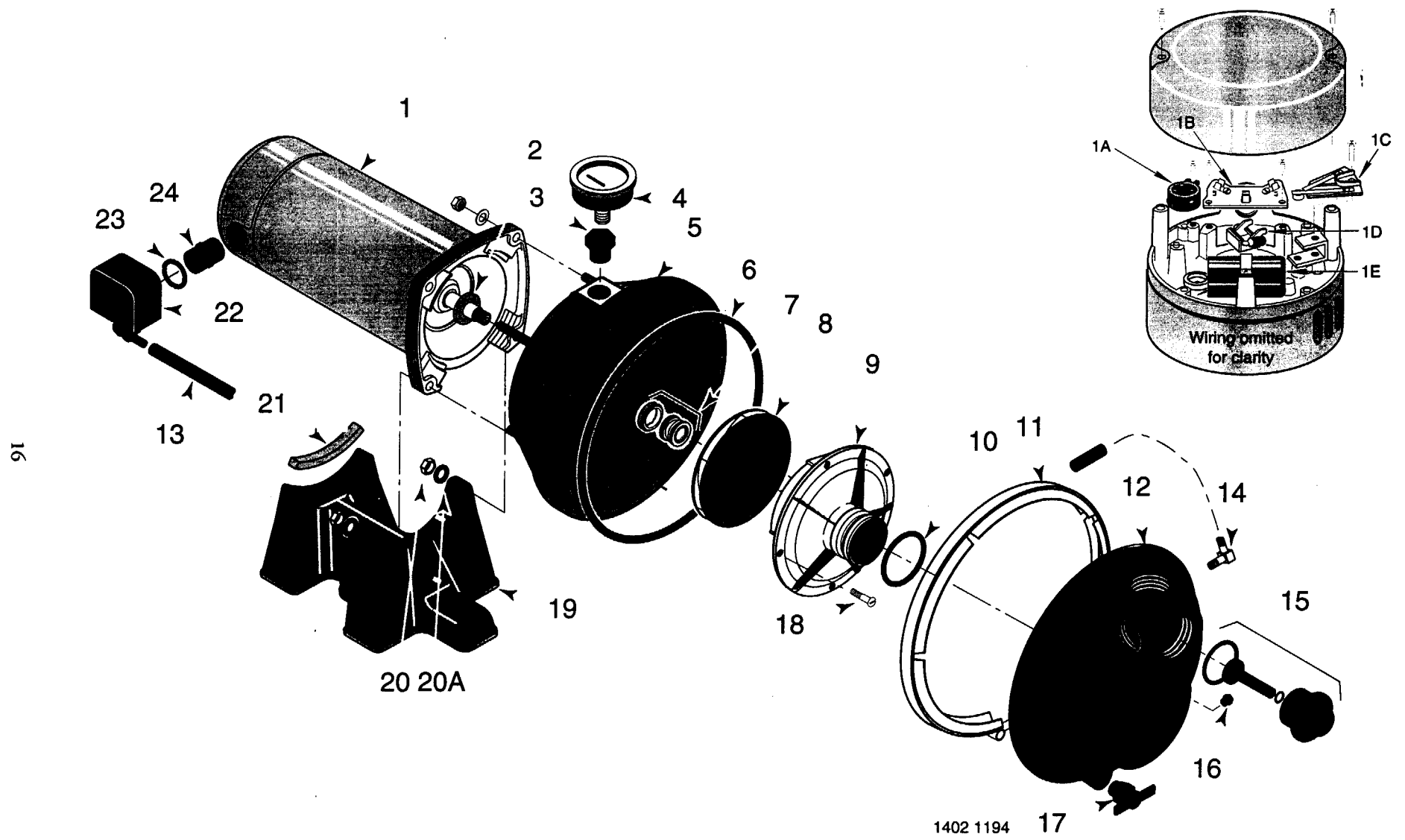

Figure 14

1402 1194 17



Key No.	1/2 HP Model 390.251182	3/4 HP Model 390.251982	1 HP Model 390.252282	Part Description
1	J218-995C	-	-	Motor - 1/2 HP, 115/230V, 60 Cycle
1	-	J218-954C	-	Motor - 3/4 HP, 115/230V, 60 Cycle
1	-	-	J218-955C	Motor - 1 HP, 115/230V, 60 Cycle
1A	-	U18-1155	U18-1140	Overload Protector
1B	U18-1180	U18-1180	U18-1180	Terminal Board
1C	U18-1098	U18-1098	U18-1098	Contactator
1D	U18-128	U18-128	U18-128	Governor
1E	-	U18-526	U18-526	Capacitor
2	C69-2	C69-2	C69-2	Water Slinger
3	U78-107PT	U78-107PT	U78-107PT	Reducer Bushing - 1/2" x 1/8" NPT
4	2768	2768	2768	Pressure Gauge
5	L176-47P	L176-47P	L176-47P	Pump Body (Back Half)
6	U9-399	U9-399	U9-399	O-Ring - Pump Body - 9-1/2" x 9" x 1/4"
7	U109-6A	U109-6A	U109-6A	Shaft Seal
8	J105-40PE	J105-42PT	J105-8PAN	Impeller
9	J1-39P	J1-39P	J1-40P	Diffuser
10	U9-199	U9-199	U9-199	O-Ring - Diffuser 1-7/8" x 1-5/8" x 1/8"
11	C19-54SS	C19-54SS	C19-54SS	Clamp - Tank Body
12	L76-34P	L76-34P	L76-34P	Pump Body (Front Half)
13	U37-673P	U37-673P	U37-673P	Switch Tube
14	U111-212T	U111-212T	U111-212T	90° Hose Barb
15	L162-10PS	L162-10PS	L162-10PS	Pressure Regulator
16	WC78-41T	WC78-41T	WC78-41T	Pipe Plug - 1/8" NPT
17	U212-68T	U212-68T	U212-68T	Draincock - 1/4" NPT
18	U30-542SS	U30-542SS	U30-542SS	Screw - #8 - 32 x 7/8" Lg. (5 Required)
19	C4-42P	C4-42P	C4-42P	Base
20	U36-37ZP	U36-37ZP	U36-37ZP	Nut - 5/16" - 18 Hex. (4 Required)
20A	U43-11ZP	U43-11ZP	U43-11ZP	Washer - 5/16" (4 Required)
21	C35-11	C35-11	C35-11	Motor Pad
22	2781	2782	2782	Pressure Switch
23	U36-112ZP	U36-112ZP	U36-112ZP	Locknut - 1/2"
24	L43-5C	L43-5C	L43-5C	Connector

# REPAIR PARTS

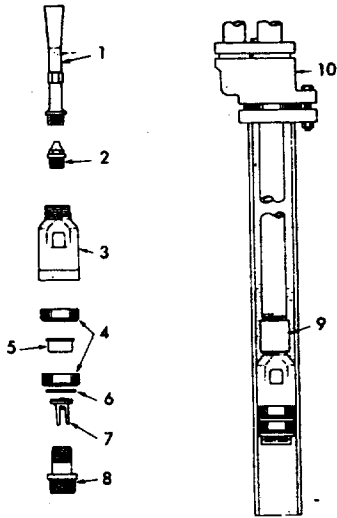

Single Pipe Jets

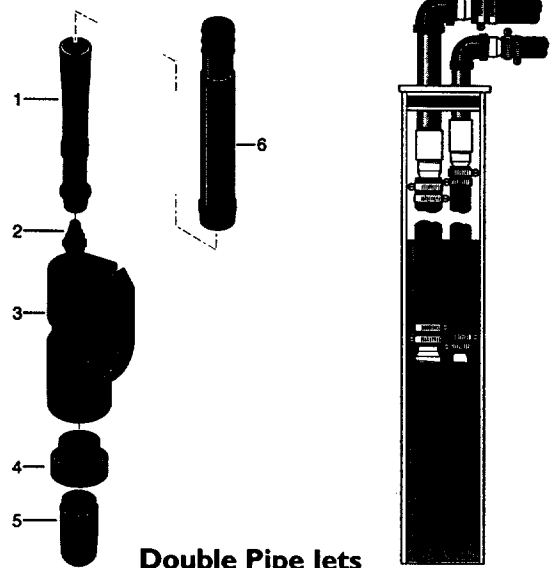

Double Pipe Jets

## SINGLE PIPE JETS

Jet Size	Pump Model	Jet Pkg. Stock No.	Max. Pumping Depth	Part Description										
				1	2	No. Stamped On Nozzle	3	4	5	6	7	8	9	10
				Venturi	Nozzle*		Jet Body	Packer Leather	Spacer	Washer	Check Valve	Valve Seat	Turned Coupling	Casing Adapter
2"	390.251182	29670	40'	J32P-24	J34P-44	54	J40-24	J57-1	J43-14P	-	P122-10B	J66-13	U11-1	J216-13
			70'	J32P-18	J34P-42	52	J40-24	J57-1	J43-14P	-	P122-10B	J66-13	U11-1	J216-13
	390.251982		80'	J32P-18	J34P-42	52	J40-24	J57-1	J43-14P	-	P122-10B	J66-13	U11-1	J216-13
	390.252282		90'	J32P-18	J34P-42	52	J40-24	J57-1	J43-14P	-	P122-10B	J66-13	U11-1	J216-13
3"	390.251182	29902	40'	J32P-24	J34P-41	51	J40-25	J57-3	J43-16	J43-20C	J161-3	J66-14	-	J216-14
			60'	J32P-18	J34P-42	52	J40-25	J57-3	J43-16	J43-20C	J161-3	J66-14	-	J216-14
	390.251982		60'	J32P-24	J34P-41	51	J40-25	J57-3	J43-16	J43-20C	J161-3	J66-14	-	J216-14
			90'	J32P-18	J34P-42	52	J40-25	J57-3	J43-16	J43-20C	J161-3	J66-14	-	J216-14
	390.252282		70'	J32P-22	J34P-43	53	J40-25	J57-3	J43-16	J43-20C	J161-3	J66-14	-	J216-14
			90'	J32P-18	J34P-42	52	J40-25	J57-3	J43-16	J43-20C	J161-3	J66-14	-	J216-14

## DOUBLE PIPE JETS

Jet Size	Pump Model	Jet Pkg. Stock No.	Max. Pumping Depth	Part Description						
				1	2	No. Stamped On Nozzle	3	4	5	6
				Venturi	Nozzle*		Jet Body	Check Valve	Strainer	Plastic Pipe Adapter
4"	390.251182	29660	40'	J32P-24	J34P-41	51	N40-92	N212-12P	L8-1P	U11-104P
			60'	J32P-18	J34P-42	52	N40-92	N212-12P	L8-1P	U11-104P
	390.251982		60'	J32P-24	J34P-41	51	N40-92	N212-12P	L8-1P	U11-104P
			90'	J32P-18	J34P-42	52	N40-92	N212-12P	L8-1P	U11-104P
	390.252282		70'	J32P-22	J34P-43	53	N40-92	N212-12P	L8-1P	U11-104P
			90'	J32P-18	J34P-42	52	N40-92	N212-12P	L8-1P	U11-104P

\*Order Nozzle Replacement Part by this Part Number.

# REPAIR PARTS

## VERTICAL CASING ADAPTERS

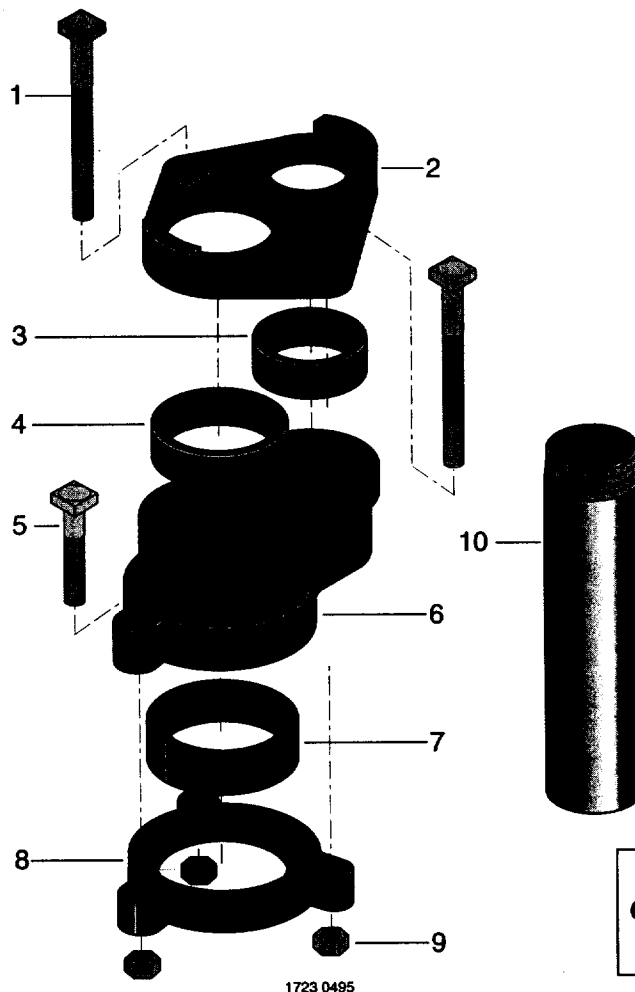

**To Order Parts,  
Call Sears Product Service,  
1-800-366-7278**

## 2" AND 3" VERTICAL CASING ADAPTER

Key No.	2" Vertical Casing Adapter	3" Vertical Casing Adapter	Part Description
-	J216-13	-	2" Vertical Casing Adapter
-	-	J216-14	3" Vertical Casing Adapter
1	U30-282ZP	U30-282ZP	Machine Bolt 3/8-16 x 5" Lg. (2 Req.)
2	J16-19ZZP	J16-23ZZP	Upper Flange
3	J21-19	J21-19	Seal Ring - Drive Pipe
4	J21-18	J21-18	Seal Ring - Suction Pipe
5	U30-277ZP	U30-277ZP	Machine Bolt 3/8-16 x 2-1/2" Lg.
6	J51-1ZZP	J51-3ZZP	Casing Adapter Body
7	J21-17	J21-21	Seal Ring - Lower
8	J16-20ZZP	J16-24ZZP	Lower Flange
9	U36-38ZP	U36-38ZP	Nut 3/8" Sq. Hd. (3 Req.)
10*	U37-116GP	U37-116GP	1" x 6" Nipple

\*Furnished with Jet Package.

# SEARS

## OWNER'S MANUAL

### MODEL NO.

390.251182

390.251982

390.252282

The model number of your Deep Well Jet Pump will be found on the pump body.

When requesting service or ordering parts, always give the following information:

- Product Type
- Model Number
- Part Number
- Part Description

# CRAFTSMAN<sup>®</sup> "HYDROGLASS"<sup>®</sup> CONVERTIBLE DEEP WELL JET PUMP

For the repair or replacement parts you need

Call 7 am - 7 pm, 7 days a week

**1-800-366-PART**

(1-800-366-7278)



For in-home major brand repair service

Call 24 hours a day, 7 days a week

**1-800-4-REPAIR**

(1-800-473-7247)



For the location of a  
Sears Repair Service Center in your area

Call 24 hours a day, 7 days a week

**1-800-488-1222**



For information on purchasing a Sears  
Maintenance Agreement or to inquire

about an existing Agreement

call 9 am - 5 pm, Monday-Saturday

**1-800-827-6655**



**SEARS**  
**REPAIR SERVICES**

*America's Repair Specialists*

Sears, Roebuck and Co., Hoffman Estates, IL 60179 U.S.A.

## Free Manuals Download Website

<http://myh66.com>

<http://usermanuals.us>

<http://www.somanuals.com>

<http://www.4manuals.cc>

<http://www.manual-lib.com>

<http://www.404manual.com>

<http://www.luxmanual.com>

<http://aubethermostatmanual.com>

Golf course search by state

<http://golfingnear.com>

Email search by domain

<http://emailbydomain.com>

Auto manuals search

<http://auto.somanuals.com>

TV manuals search

<http://tv.somanuals.com>