

MDR-RF950

SERVICE MANUAL

Ver 1.0 1998.06

*US Model
Canadian Model*



MDR-RF950 is headphones
in MDR-RF950RK.

SPECIFICATIONS

General

Carrier frequency 913.0 – 915.0 MHz
Channel Ch1, Ch2, Ch3
Modulation FM stereo
Frequency response 18 – 22,000 Hz

Headphones

Power source DC 3 V: 2 × R6 (size AA) battery or
2 × supplied
NC-AA-HJ Ni-Cd
rechargeable battery
Mass Approx. 265 g (9.4 oz.) incl.
Ni-cd batteries

Design and specifications are subject to change without
notice.

TABLE OF CONTENTS

| | |
|---|----|
| 1. GENERAL | 2 |
| 2. DISASSEMBLY | 3 |
| 3. ELECTRICAL ADJUSTMENTS | |
| 3-1. Checking/Adjusting Receiving Frequency | 5 |
| 3-2. Checking/Adjusting Degree of Modulation of Main Carrier (L + R) | 6 |
| 3-3. Checking/Adjusting Separation | 7 |
| 4. DIAGRAMS | |
| 4-1. Printed Wiring Boards | 11 |
| 4-2. Schematic Diagram | 13 |
| 5. EXPLODED VIEWS | 15 |
| 6. ELECTRICAL PARTS LIST | 17 |

Notes on chip component replacement

- Never reuse a disconnected chip component.
- Notice that the minus side of a tantalum capacitor may be damaged by heat.

WIRELESS STEREO HEADPHONES



SONY®

SECTION 1 GENERAL

▶ Operating the system

Setting up the headphones

- 1 Open the battery compartment lid on the left outer side of the head band.

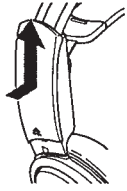

- 2 Insert two charged NC-AA-HJ batteries by matching the \oplus and \ominus on the batteries to the \oplus and \ominus in the battery compartment.

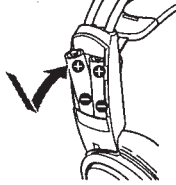

- 3 Close the battery compartment lid.

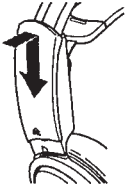

Using the headphones with a commercially available size AA (R6) dry batteries
Install the batteries in the manner as described in "Setting up the headphones."

Battery life

| Battery | Approx. hours* |
|--------------------------------|----------------|
| Sony alkaline battery SG (LR6) | 60 |
| Sony battery SR (R6P) | 30 |

* at 1 kHz, 1 mW + 1 mW output

Notes on batteries

To avoid damage to the system caused by battery leakage and corrosion,

- Install the batteries with the correct polarity.
- Do not try to recharge dry batteries.
- Remove the batteries if the system is not to be used for a long period of time.

In case of battery leakage, wipe off any deposit in the battery compartments before installing new batteries.

Check the remaining power of the headphones' battery

Pull up the self adjusting band, and check that the headphones' power indicator lights in red. You can now use the headphones.

Charge the battery or install a new dry battery, if the power indicator light is weak or turned off and the sound become distorted or has a lot of noise.

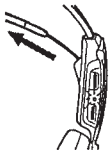

Notes

- * During recharging, the transmitter is turned off.
- * When the life of the rechargeable batteries are shortened by half even after a proper recharging, replace them with new NC-AA-HJ batteries.

Listening to a program

- 1 First turn on the audio/video equipment, then the transmitter.

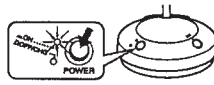

- 2 Select the radio frequency with the CHANNEL selector switch.

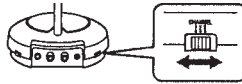

- 3 Put on the headphones and the power turns on automatically.



- 4 Turn up the volume to a moderate level with the VOL control, then tune the headphones to the transmitte frequency with the TUNING control until you can hear the audio signal loud and clear.

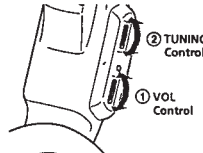

Try the above steps 2 and 4 until the receiving performance becomes better.

Sending RF signals from the Transmitter

The transmitter starts sending the RF signals automatically, when the transmitter power is turned on, and audio signals from the connected equipment is detected.

If it does not detect an audio signal for more than approximately five minutes, the transmitter will stop sending RF signals.

But the Power indicator remains lighting. When the transmitter receives an audio signal again, it starts sending the RF signals.

If the audio signal is very weak, the transmitter does not send RF signals automatically. In this case, make sure the volume of the equipment connected is set to 5 - 6.

You may not hear the beginning of the sound from the headphones until the transmitter starts sending the RF signals after detecting an audio signal.

Note

If the transmitter is connected to the headphones jack of the source equipment, set the volume of that equipment as high as possible without distorting the audio signal.

Auto power on/off function

When you remove the headphones, the power turns off automatically. Do not allow the self adjusting band to be pulled up, otherwise the headphones will be switched on.

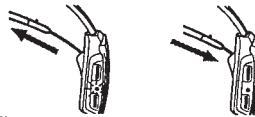

Mute function

If a hissing noise is heard when the headphones are used outside of the effective range (see the next section), the mute function will be activated and the sound will not be heard from the headphones. To restore the sound, move near toward the transmitter.

After listening to a program

Take the headphones off and rest them away on the holder of the transmitter as shown below.

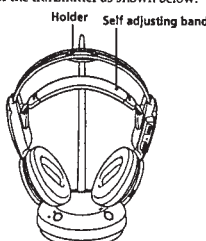

Note

Do not hang the headphones by the self adjusting band, otherwise, the self adjusting band will be pulled up and the headphones will be switched on.

The effective areas of the transmitter

The optimum distance is up to approximately 150 feet (46 m) without the system picking up some interference. However, the distance may vary according to the surroundings and environment. If the system picks up some noise while using it within the above mentioned distance, reduce the distance between the transmitter unit and the headphones, or select the other channel.

Notes

- * When you use the headphones inside the effective areas of the transmitter, the transmitter can be placed in any direction from the listener.
- * Even within the signal reception area, there are some spots (dead spot) where the RF signal can not be received. This characteristics is inherent to RF signals, and does not indicate malfunction. By slightly moving the transmitter, location of the dead spot can be changed.

Replacing the ear pads

When the ear pads become dirty or damaged, you can get replacements from your Sony dealer. Replace them as illustrated below.

- 1 Remove the old ear pad by pulling it out of the groove on the housing.

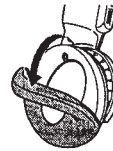

- 2 Place the new ear pad on the driver unit and insert the edge of the pad into the groove as illustrated.

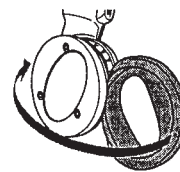

Make sure that the entire edge of the ear pad is securely inserted into the groove.

▶ Additional information

Precautions

- * When the headphones are not to be used for a long period of time, remove the batteries to avoid damage caused by battery leakage and subsequent corrosion.
- * When the transmitter is not to be used for a long period of time, disconnect the AC power adaptor from the AC outlet holding the plug. Do not pull on the cord. Also remove the batteries to avoid damage caused by battery leakage and subsequent corrosion.
- * Do not leave the wireless stereo headphone system in a location subject to direct sunlight, heat or moisture.

Notes on headphones

Preventing hearing damage

Avoid using headphones at high volume. Hearing experts advise against continuous, loud and extended play. If you experience a ringing in your ears, reduce the volume or discontinue use.

Caring for others

Keep the volume at a moderate level. This will allow you to hear outside sounds and to be considerate to the people around you.

If you have any questions or problems concerning the system that are not covered in this manual, please consult the nearest Sony dealer.

Be sure to bring the headphones and the transmitter to the Sony dealer when requiring repair work.

SECTION 2 DISASSEMBLY

- This set can be disassembled in the order shown below.



Note: Follow the disassembly procedure in the numerical order given.

FRONT PLATE ASSY

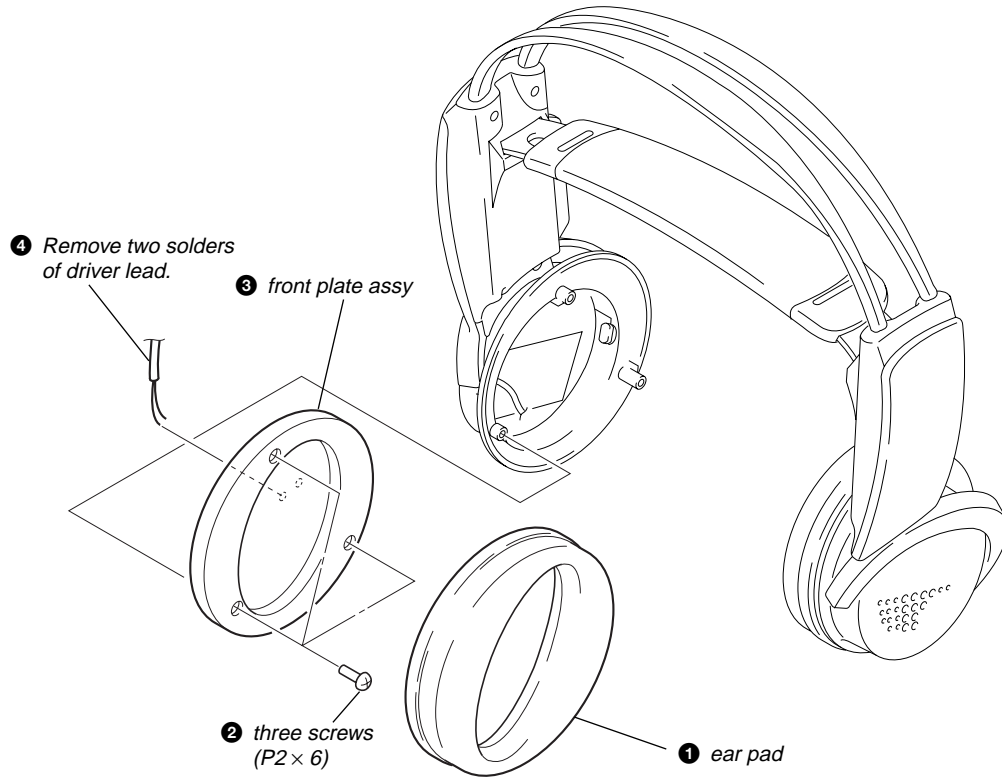

RX-BASE BOARD

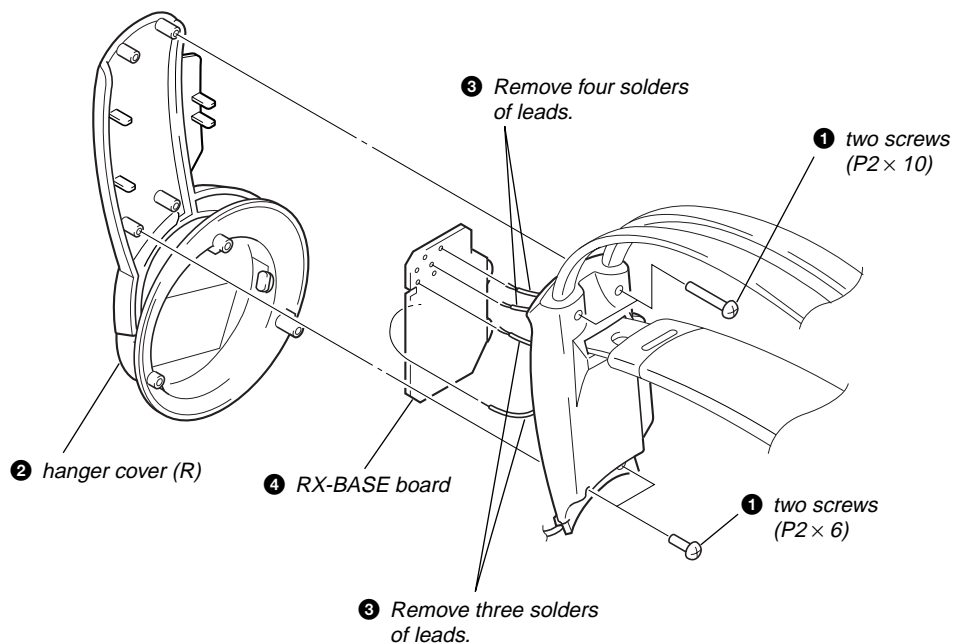

SW BOARD

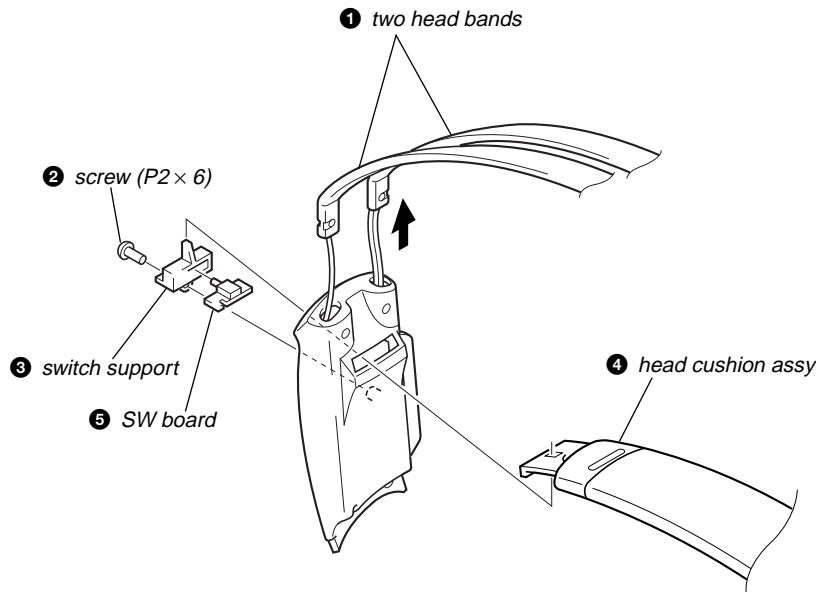

HANGER COVER (L)

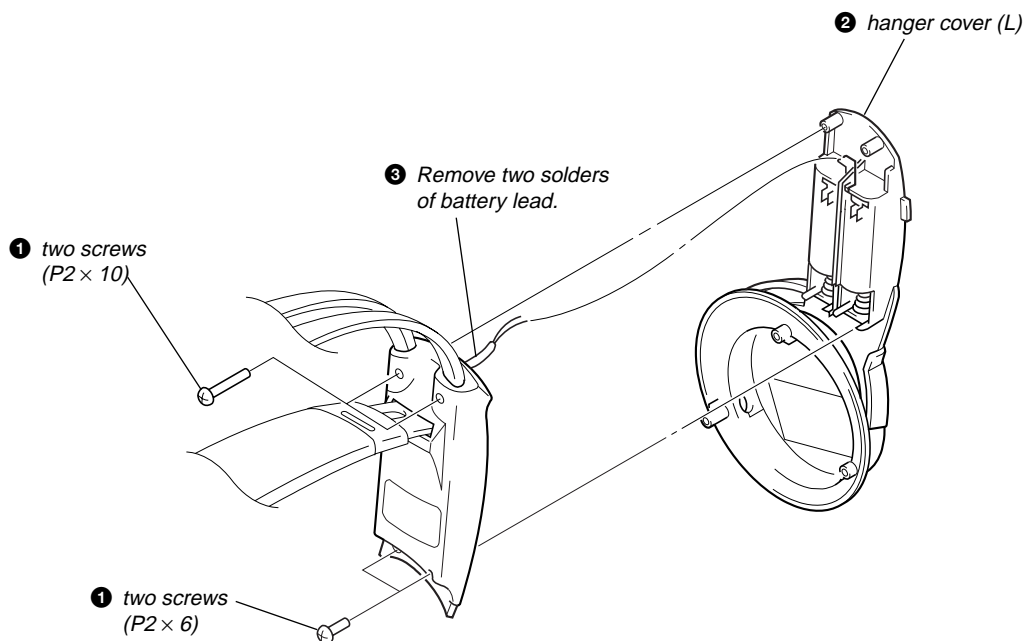

SECTION 3 ELECTRICAL ADJUSTMENTS

Note:

1. The adjustments should be performed in the order given.
2. The transmitter (TMR-RF950R) already checked and adjusted should be used.

3-1. Receiving Frequency Check and Adjustment

Preparation:

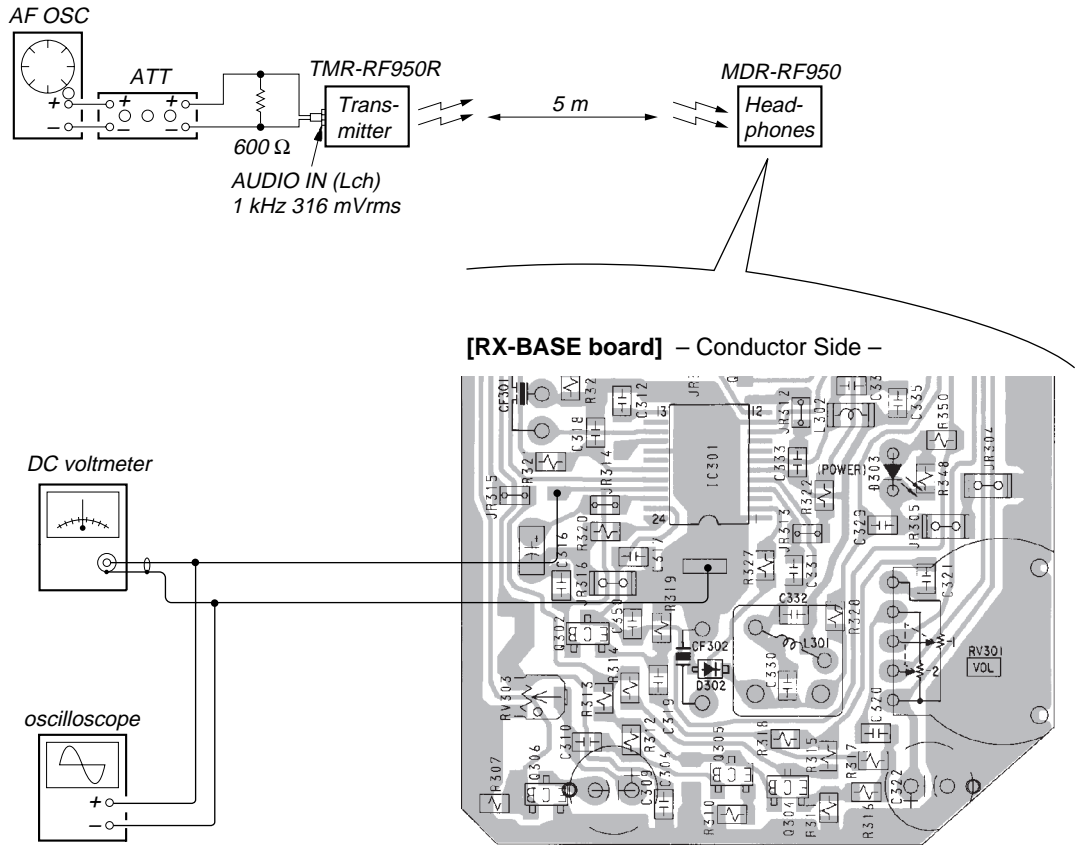

Procedure:

1. Set the channel of the transmitter to CH2.
2. Turn OFF the noise filter switch on the transmitter.
3. Enter 1 kHz 316 mVrms signal only to the Lch on the transmitter.
4. Place the transmitter away from the headphone (MDR-RF950) more than 5 m.
5. Set the volume control (RV301) on the RX-BASE board to the minimum position.
6. Set the tuning control (RV302) on the RX-BASE board to the center position.
7. Connect a DC voltmeter and an oscilloscope between IC301 pin ② and ground on the RX-BASE board.
8. After confirming that demodulated 1 kHz waveform (about 13 mV) appears on the oscilloscope, check that the DC voltmeter indicates DC1 V to 1.2 V.
9. If demodulated 1 kHz waveform does not appear on the oscilloscope, or if the voltage is out of the specified value, adjust the air-core coil (L301) on the RX-BASE board so that the demodulated 1 kHz waveform appears on the oscilloscope, and under this condition, adjust finely the air-core coil (L301) so that the DC voltmeter indicates DC1.1 V.
10. Finally, check that signals are received when the channel is changed over to CH1/CH3 on the transmitter, then when the tuning control (RV302) on the RX-BASE board is rotated.

Adjustment Location: RX-BASE board (See page 9.)

3-2. Degree of Modulation of Main Carrier (L + R) Check and Adjustment

Preparation:

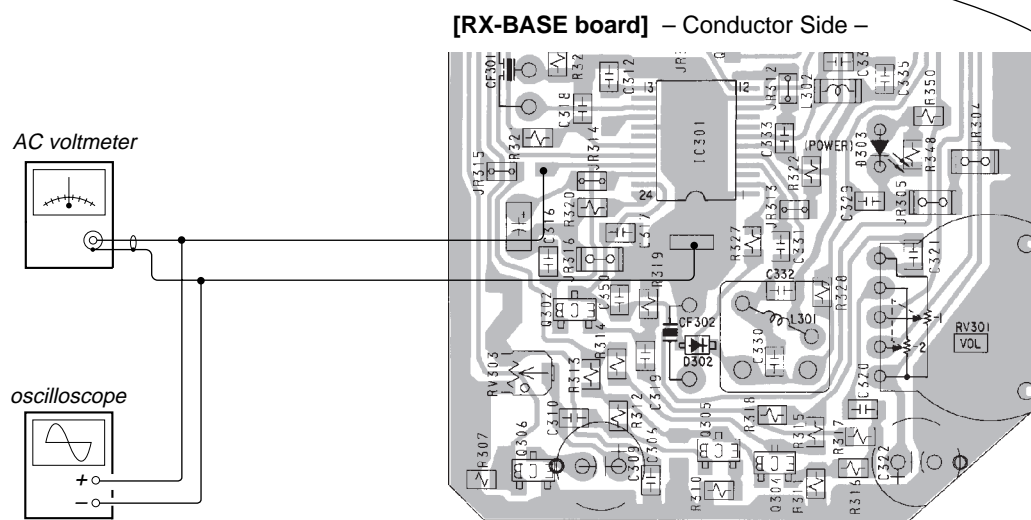
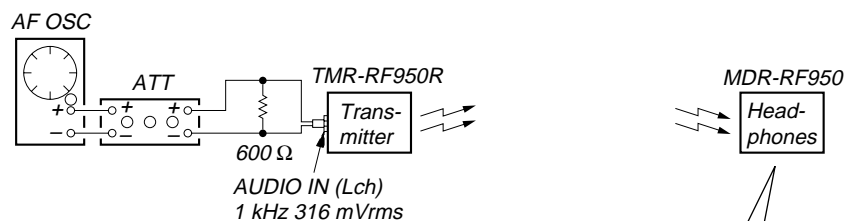

Procedure:

1. Set the channel of the transmitter to CH2.
2. Turn OFF the noise filter switch on the transmitter.
3. Enter 1 kHz 316 mVrms signal only to the Lch on the transmitter.
4. Set the volume control (RV301) on the RX-BASE board to the minimum position.
5. Connect an AC voltmeter and an oscilloscope between IC 301 pin ② and ground on the RX-BASE board.
6. Rotating the tuning control (RV302) on the RX-BASE board, receive signals.
7. After confirming that demodulated 1 kHz waveform appears on the oscilloscope, check that the AC voltmeter indicates 12 mVrms to 15 mVrms.
8. If out of the specified value, rotate RV404 on the TX-BASE board in the transmitter (TMR-RF950R) so as to attain 13.5 mVrms.

Adjustment Location: TX-BASE board in the transmitter (TMR-RF950R) (See page 8.)

3-3. Separation Check and Adjustment

Preparation:

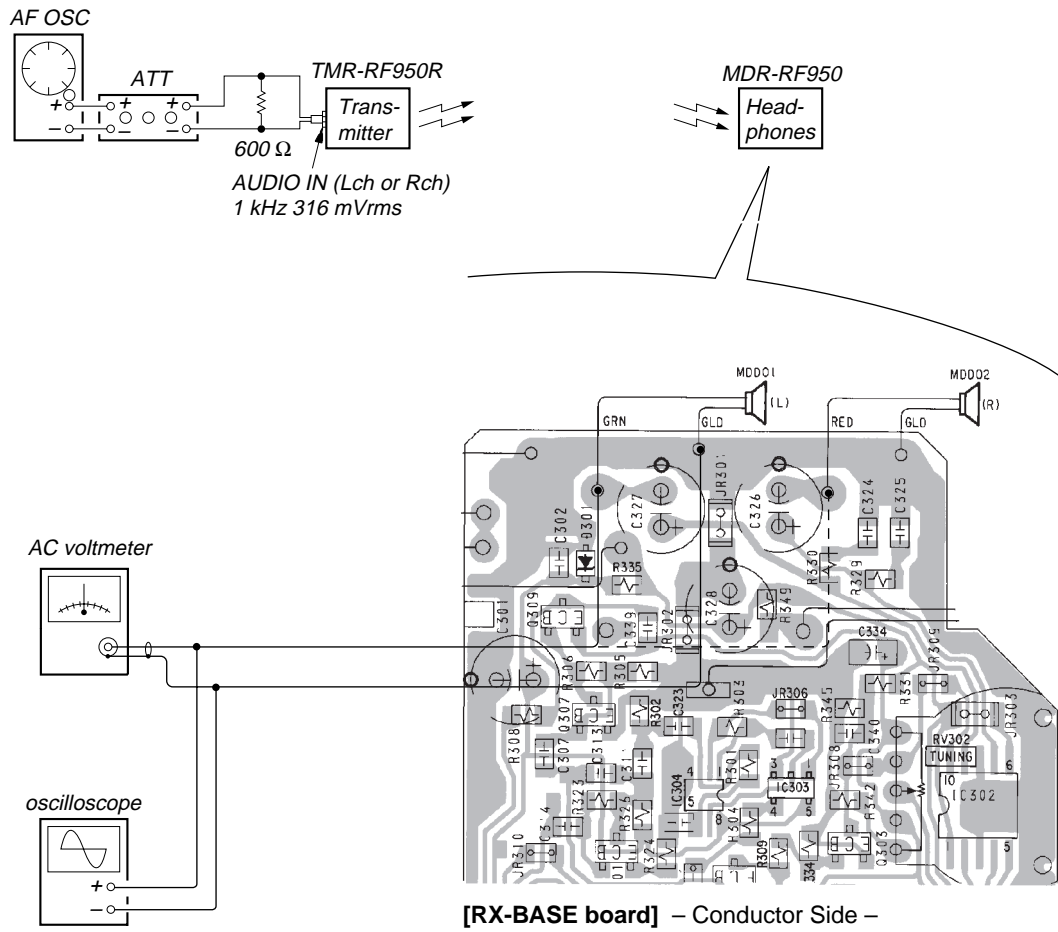

Procedure:

1. Set the channel of the transmitter to CH2.
2. Turn OFF the noise filter switch on the transmitter.
3. Enter 1 kHz 316 mVrms signal only to the Lch on the transmitter.
4. Connect an AC voltmeter and an oscilloscope to the Lch speaker output (both ends of MDD01) on the RX-BASE board.
5. Rotating the tuning control (RV302) on the RX-BASE board, receive signals.
6. Adjust the volume control (RV301) on the RX-BASE board so that the Lch speaker output (both ends of MDD01) on the RX-BASE board becomes 155 mVrms.
7. Connect an AC voltmeter and oscilloscope to the Rch speaker output (both ends of MDD02) and measure voltage.
8. Check that a difference in speaker output level between Lch and Rch (i. e., separation) is over 20 dB. If not over 20 dB, rotate RV303 on the RX-BASE board to minimize the Rch output, then reconfirm that a difference in speaker output level between Lch and Rch is over 20 dB.
9. Enter 1kHz 316 mVrms signal only to the Rch on the transmitter.
10. Adjust the volume control (RV301) on the RX-BASE board so that the Rch speaker output (voltage across MDD02) on the RX-BASE board become 155 mVrms.
11. Connect an AC voltmeter and oscilloscope to the Lch speaker output (both ends of MDD01) and measure voltage.
12. Check that a difference in speaker output level between Lch and Rch (i.e., separation) is over 20 dB.

Adjustment Location: RX-BASE board (See page 9.)

Adjustment Location:

Transmitter (TMR-RF950R)

[TX-BASE board] – Component Side –

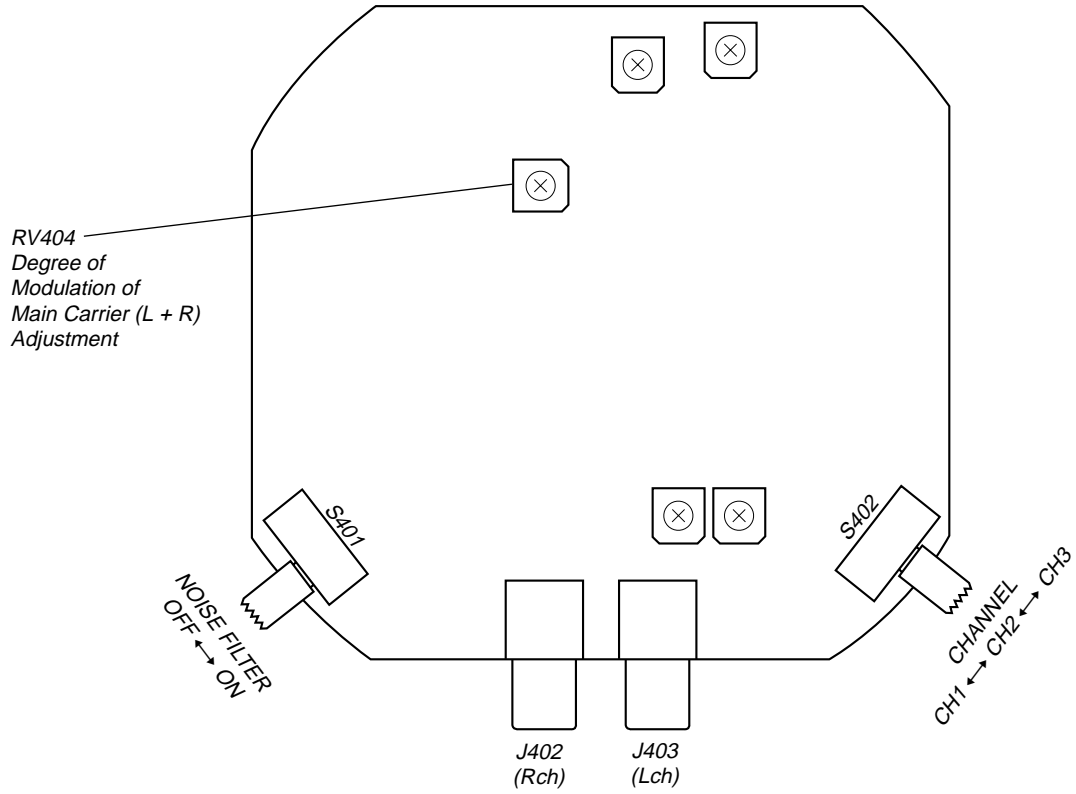

Headphone (MDR-RF950)

[RX-BASE board] – Component Side –

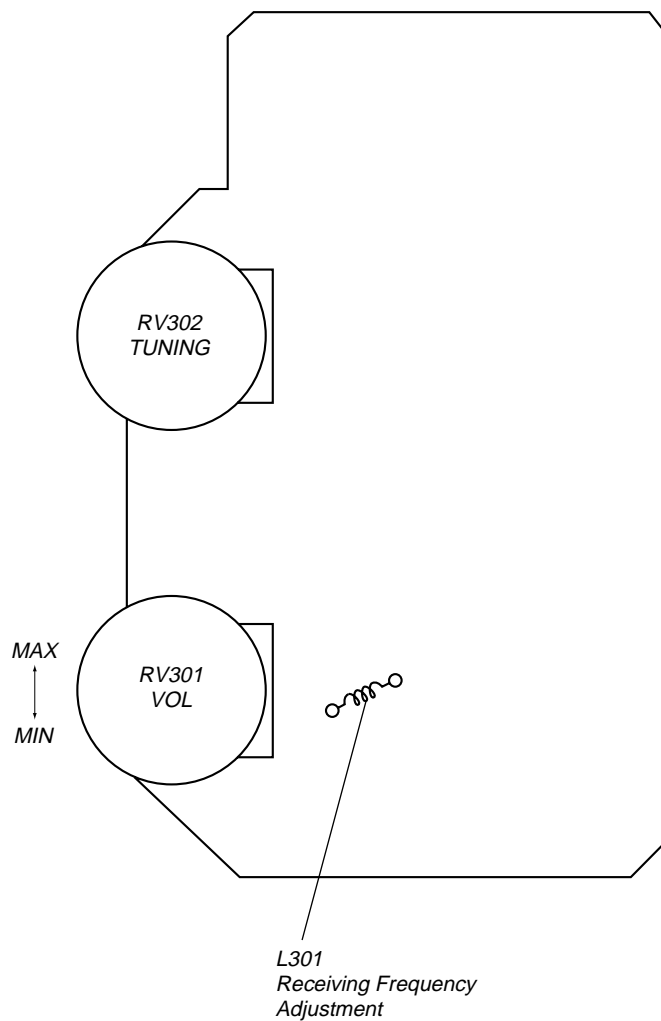

[RX-BASE board] – Conductor Side –

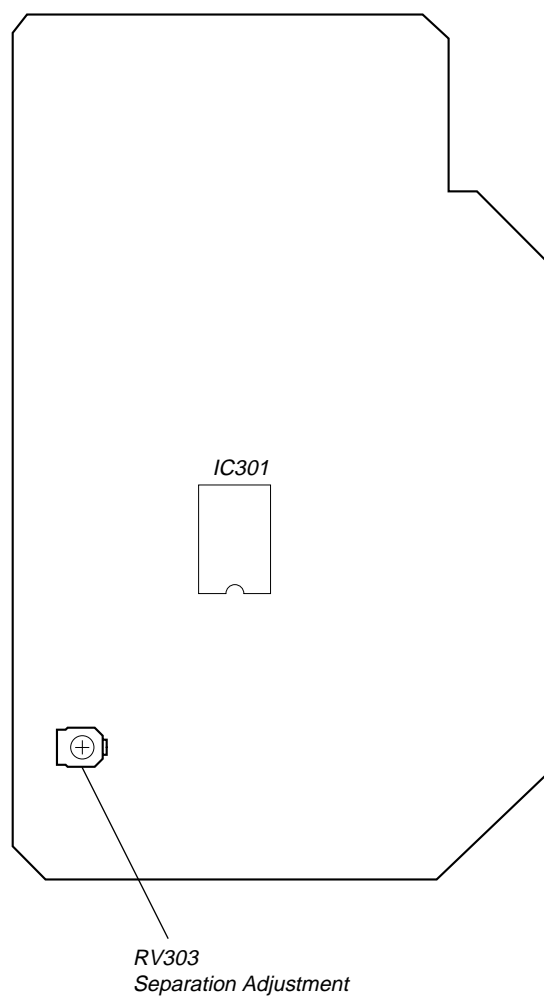

SECTION 4 DIAGRAMS

• IC Block Diagrams

IC301 CXA1611N-T4

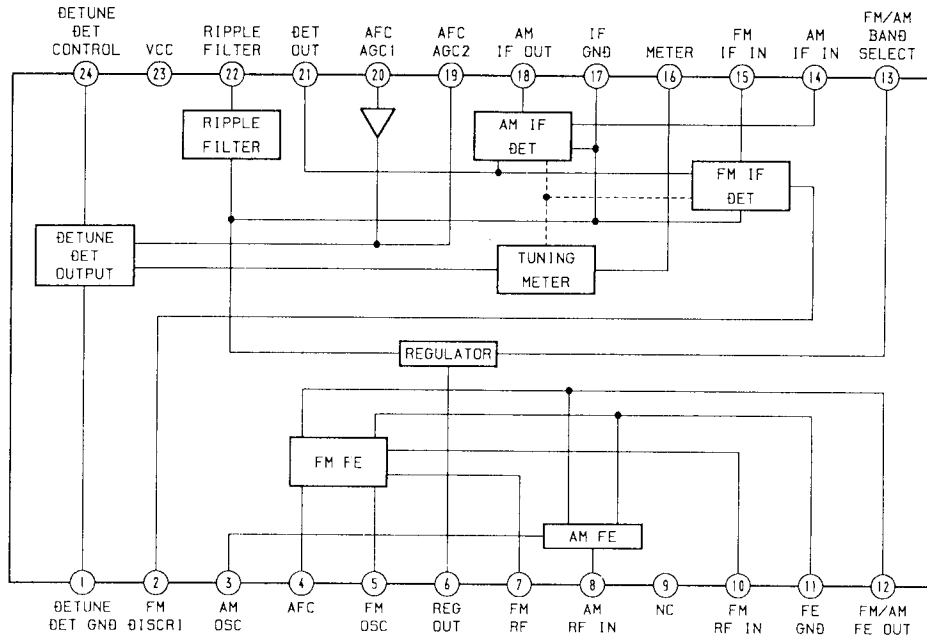

IC302 LA4533M

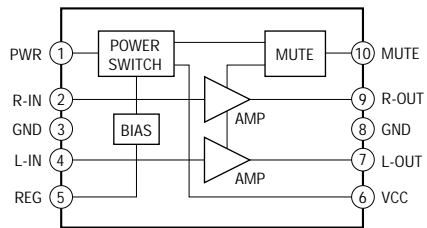

SECTION 5 EXPLODED VIEWS

NOTE:

- -XX and -X mean standardized parts, so they may have some difference from the original one.
- Color Indication of Appearance Parts
Example:
KNOB, BALANCE (WHITE) . . . (RED)
 ↑ ↑
 Parts Color Cabinet's Color
- Items marked “*” are not stocked since they are seldom required for routine service. Some delay should be anticipated when ordering these items.
- The mechanical parts with no reference number in the exploded views are not supplied.

(1) HEADPHONE (R) SECTION

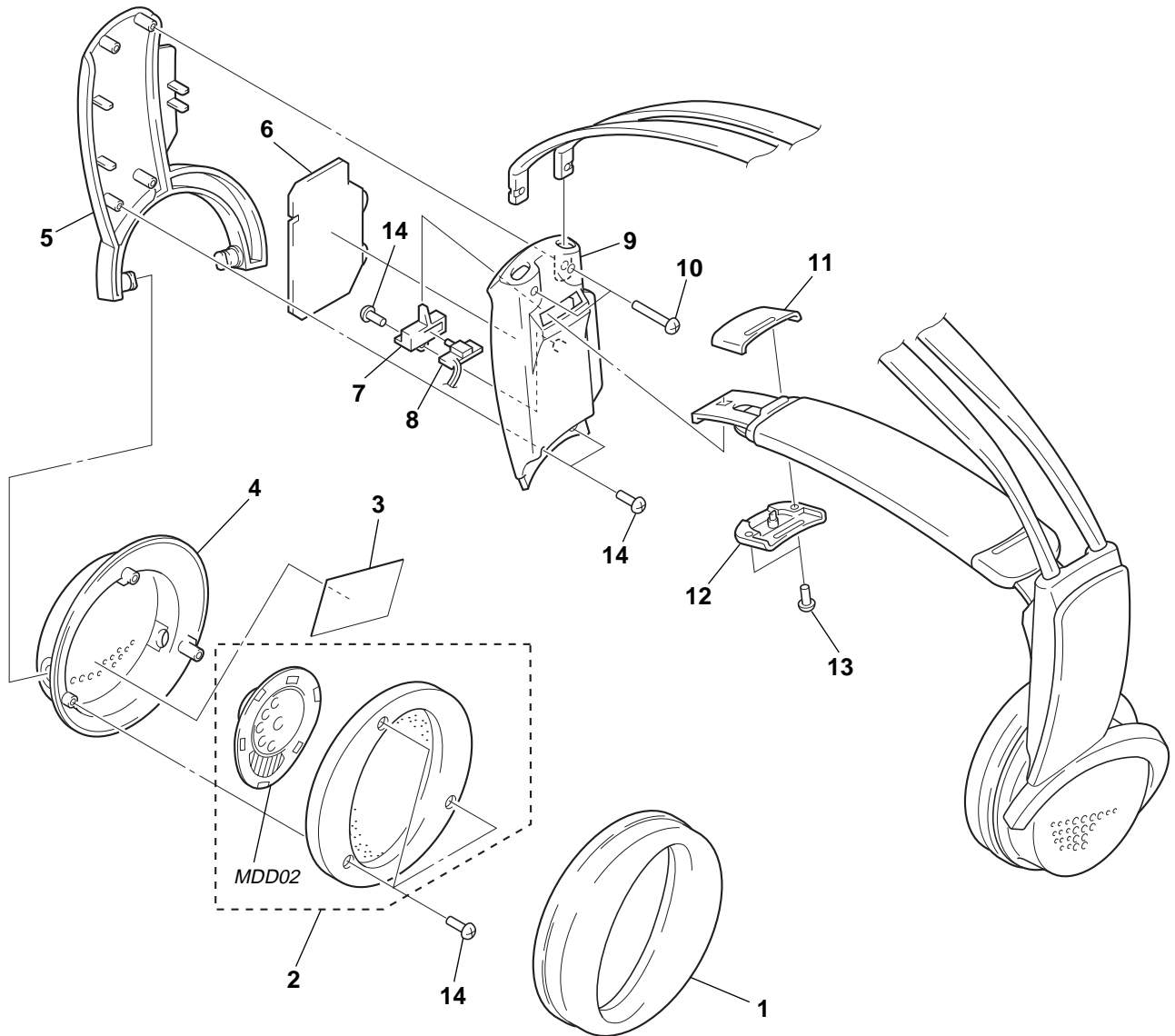

| <u>Ref. No.</u> | <u>Part No.</u> | <u>Description</u> | <u>Remark</u> | <u>Ref. No.</u> | <u>Part No.</u> | <u>Description</u> | <u>Remark</u> |
|-----------------|-----------------|-------------------------|---------------|-----------------|-----------------|------------------------------|---------------|
| 1 | 4-971-700-01 | PAD, EAR | | 9 | 4-999-767-01 | HANGER (R) | |
| 2 | X-4950-190-1 | PLATE (R) ASSY, FRONT | | 10 | 7-685-106-19 | SCREW +P 2X10 TYPE2 NON-SLIT | |
| 3 | 4-999-774-01 | REGISTER, HOUSING | | 11 | 4-966-791-11 | STOPPER (UPPER) | |
| 4 | 4-999-773-01 | HOUSING (R) | | 12 | 4-966-792-11 | STOPPER (LOWER) | |
| 5 | 4-999-769-11 | COVER (R), HANGER | | 13 | 3-318-203-62 | SCREW (B1.7X4), TAPPING | |
| * 6 | A-4542-518-A | RX-BASE BOARD, COMPLETE | | 14 | 7-685-104-19 | SCREW +P 2X6 TYPE2 NON-SLIT | |
| 7 | 4-210-255-01 | SUPPORT, SWITCH | | MDD02 | 1-505-117-21 | DRIVER (R-CH) | |
| * 8 | 1-670-527-11 | SW BOARD | | | | | |

(2) HEADPHONE (L) SECTION

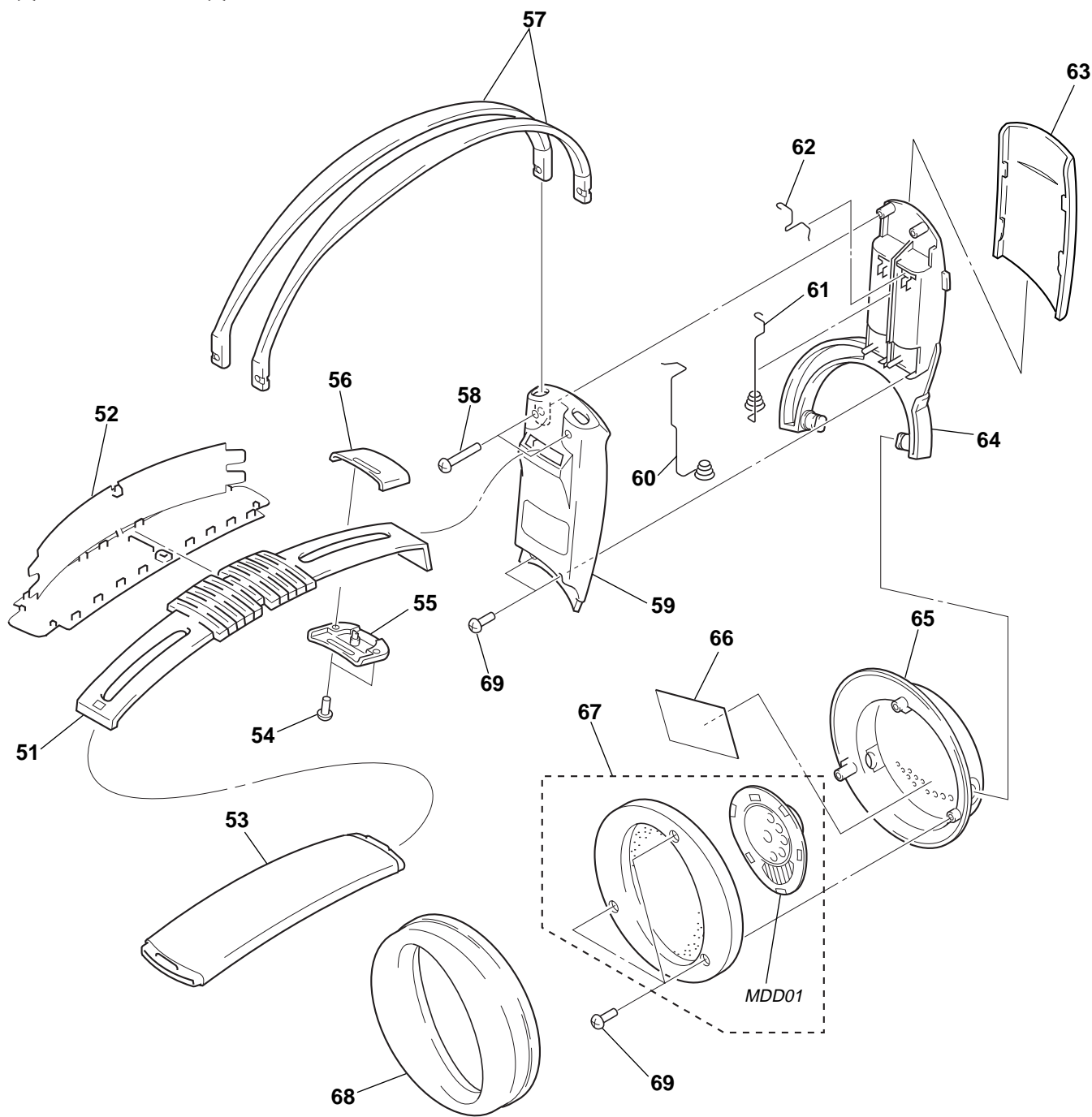

| Ref. No. | Part No. | Description | Remark | Ref. No. | Part No. | Description | Remark |
|----------|--------------|------------------------------|--------|----------|--------------|-----------------------------|--------|
| 51 | 4-999-771-01 | SUSPENDER | | 61 | 4-210-257-01 | TERMINAL (-), BATTERY | |
| 52 | 4-978-518-02 | BASE, SUSPENDER | | 62 | 4-210-256-01 | TERMINAL (+), BATTERY | |
| 53 | 4-978-519-01 | CUSHION, HEAD | | 63 | 4-999-770-11 | LID, BATTERY CASE | |
| 54 | 3-318-203-62 | SCREW (B1.7X4), TAPPING | | 64 | 4-999-768-01 | COVER (L), HANGER | |
| 55 | 4-966-792-11 | STOPPER (LOWER) | | 65 | 4-999-772-01 | HOUSING (L) | |
| 56 | 4-966-791-11 | STOPPER (UPPER) | | 66 | 4-999-774-01 | REGISTER, HOUSING | |
| 57 | 4-999-765-01 | BAND, HEAD | | 67 | X-4950-189-1 | PLATE (L) ASSY, FRONT | |
| 58 | 7-685-106-19 | SCREW +P 2X10 TYPE2 NON-SLIT | | 68 | 4-971-700-01 | PAD, EAR | |
| 59 | 4-999-766-11 | HANGER (L) (US) | | 69 | 7-685-104-19 | SCREW +P 2X6 TYPE2 NON-SLIT | |
| 59 | 4-999-766-21 | HANGER (L) (Canadian) | | MDD01 | 1-505-117-21 | DRIVER (L-CH) | |
| 60 | 4-210-258-01 | TERMINAL (MIDWAY), BATTERY | | | | | |

SECTION 6 ELECTRICAL PARTS LIST

| | |
|----|---------|
| FE | RX-BASE |
|----|---------|

NOTE:

- Due to standardization, replacements in the parts list may be different from the parts specified in the diagrams or the components used on the set.
- -XX and -X mean standardized parts, so they may have some difference from the original one.
- RESISTORS
All resistors are in ohms.
METAL: Metal-film resistor.
METAL OXIDE: Metal oxide-film resistor.
F: nonflammable

- Items marked “*” are not stocked since they are seldom required for routine service. Some delay should be anticipated when ordering these items.
- SEMICONDUCTORS
In each case, u: μ , for example:
uA. . : μ A. . uPA. . : μ PA. .
uPB. . : μ PB. . uPC. . : μ PC. .
uPD. . : μ PD. .
- CAPACITORS
uF: μ F
- COILS
uH: μ H

When indicating parts by reference number, please include the board.

| Ref. No. | Part No. | Description | Remark | Ref. No. | Part No. | Description | Remark | |
|----------|--------------|--|---------|----------|----------|--------------|--|------------------------------|
| | | FE BOARD ***** (Included in RX-BASE BOARD, COMPLETE) | | | | | | |
| | | < CAPACITOR > | | | | | | |
| C1 | 1-162-906-11 | CERAMIC CHIP | 1.5PF | | L2 | 1-469-237-21 | INDUCTOR 0.68uH | |
| C2 | 1-162-927-11 | CERAMIC CHIP | 100PF | | L3 | 1-414-665-11 | INDUCTOR CHIP 12nH | |
| C3 | 1-162-964-11 | CERAMIC CHIP | 0.001uF | | L4 | 1-414-665-11 | INDUCTOR CHIP 12nH | |
| C4 | 1-162-908-11 | CERAMIC CHIP | 3PF | | L5 | 1-414-660-11 | INDUCTOR CHIP 4.7nH | |
| C5 | 1-162-918-11 | CERAMIC CHIP | 18PF | | L6 | 1-414-660-11 | INDUCTOR CHIP 4.7nH | |
| C6 | 1-162-964-11 | CERAMIC CHIP | 0.001uF | | | | < TRANSISTOR > | |
| C8 | 1-162-910-11 | CERAMIC CHIP | 5PF | | Q1 | 8-729-046-22 | FET 3SK240 (TE85L) | |
| C9 | 1-162-920-11 | CERAMIC CHIP | 27PF | | Q3 | 8-729-230-81 | TRANSISTOR 2SC3606 | |
| C10 | 1-162-905-11 | CERAMIC CHIP | 1PF | | Q4 | 8-729-232-73 | TRANSISTOR 2SC4320 (TE85L) | |
| C12 | 1-162-915-11 | CERAMIC CHIP | 10PF | | | | < RESISTOR > | |
| C13 | 1-162-905-11 | CERAMIC CHIP | 1PF | | R1 | 1-216-845-11 | METAL CHIP 100K 5% 1/16W | |
| C14 | 1-162-925-11 | CERAMIC CHIP | 68PF | | R4 | 1-216-853-11 | METAL CHIP 470K 5% 1/16W | |
| C15 | 1-162-927-11 | CERAMIC CHIP | 100PF | | R5 | 1-216-845-11 | METAL CHIP 100K 5% 1/16W | |
| C16 | 1-162-906-11 | CERAMIC CHIP | 1.5PF | | R7 | 1-216-809-11 | METAL CHIP 100 5% 1/16W | |
| C17 | 1-162-964-11 | CERAMIC CHIP | 0.001uF | | R8 | 1-218-293-11 | RES.CHIP 24K 5% 1/16W | |
| C20 | 1-162-964-11 | CERAMIC CHIP | 0.001uF | | R10 | 1-216-845-11 | METAL CHIP 100K 5% 1/16W | |
| C21 | 1-162-964-11 | CERAMIC CHIP | 0.001uF | | R11 | 1-216-810-11 | METAL CHIP 120 5% 1/16W | |
| C23 | 1-162-906-11 | CERAMIC CHIP | 1.5PF | | R12 | 1-216-809-11 | METAL CHIP 100 5% 1/16W | |
| C24 | 1-162-906-11 | CERAMIC CHIP | 1.5PF | | | | < CAPACITOR > | |
| C28 | 1-162-917-11 | CERAMIC CHIP | 15PF | | THC1 | 1-104-511-51 | CERAMIC 0.001uF | |
| C30 | 1-162-921-11 | CERAMIC CHIP | 33PF | | THC2 | 1-111-231-43 | CERAMIC 2PF 99% | |
| C39 | 1-162-964-11 | CERAMIC CHIP | 0.001uF | | THC3 | 1-111-231-43 | CERAMIC 2PF 99% | |
| C40 | 1-162-909-11 | CERAMIC CHIP | 4PF | | | | < SAW RESONANTOR > | |
| C41 | 1-162-910-11 | CERAMIC CHIP | 5PF | | X1 | 1-767-906-11 | RESONANTOR, SAW | |
| C43 | 1-162-964-11 | CERAMIC CHIP | 0.001uF | | ***** | | | |
| C44 | 1-162-927-11 | CERAMIC CHIP | 100PF | | * | A-4542-518-A | RX-BASE BOARD, COMPLETE ***** (Including FE BOARD) | |
| | | < IC > | | | | | | |
| IC1 | 8-759-469-63 | IC S-81215SGUP-DQK-T1 | | | | | < CAPACITOR > | |
| | | < RESISTOR > | | | | | | |
| JR1 | 1-216-864-11 | METAL CHIP | 0 | 5% | 1/16W | C301 | 1-126-154-11 | ELECT 47uF 20% 6.3V |
| JR2 | 1-216-864-11 | METAL CHIP | 0 | 5% | 1/16W | C302 | 1-164-489-11 | CERAMIC CHIP 0.22uF 10% 16V |
| | | < COIL > | | | | C303 | 1-163-239-11 | CERAMIC CHIP 33PF 5% 50V |
| L1 | 1-469-237-21 | INDUCTOR | 0.68uH | | | C306 | 1-163-037-11 | CERAMIC CHIP 0.022uF 10% 25V |
| | | | | | | C307 | 1-163-121-11 | CERAMIC CHIP 150PF 5% 50V |
| | | | | | | C309 | 1-126-572-11 | ELECT 4.7uF 20% 35V |
| | | | | | | C310 | 1-164-004-11 | CERAMIC CHIP 0.1uF 10% 25V |

RX-BASE

| Ref. No. | Part No. | Description | Remark | Ref. No. | Part No. | Description | Remark |
|----------|--------------|----------------------|------------|----------|--------------|---------------------------|----------|
| C311 | 1-163-243-11 | CERAMIC CHIP 47PF | 5% 50V | JR311 | 1-216-295-00 | SHORT | 0 |
| C312 | 1-163-021-00 | CERAMIC CHIP 0.01uF | 10% 50V | JR312 | 1-216-295-00 | SHORT | 0 |
| C313 | 1-163-113-00 | CERAMIC CHIP 68PF | 5% 50V | JR313 | 1-216-295-00 | SHORT | 0 |
| C314 | 1-163-125-00 | CERAMIC CHIP 220PF | 5% 50V | JR314 | 1-216-295-00 | SHORT | 0 |
| C315 | 1-124-233-11 | ELECT 10uF | 20% 16V | JR315 | 1-216-295-00 | SHORT | 0 |
| C316 | 1-163-023-00 | CERAMIC CHIP 0.015uF | 5% 50V | JR316 | 1-216-296-00 | SHORT | 0 |
| C317 | 1-163-021-00 | CERAMIC CHIP 0.01uF | 10% 50V | | | < COIL > | |
| C318 | 1-164-346-11 | CERAMIC CHIP 1uF | 16V | | | | |
| C319 | 1-164-505-11 | CERAMIC CHIP 2.2uF | 16V | L301 | 1-416-796-11 | COIL, AIR-CORE | |
| C320 | 1-164-346-11 | CERAMIC CHIP 1uF | 16V | L302 | 1-412-933-11 | INDUCTOR 0.33uH | |
| C321 | 1-164-346-11 | CERAMIC CHIP 1uF | 16V | | | < TRANSISTOR > | |
| C322 | 1-124-242-00 | ELECT 33uF | 20% 25V | Q301 | 8-729-230-49 | TRANSISTOR 2SC2712-YG | |
| C323 | 1-163-243-11 | CERAMIC CHIP 47PF | 5% 50V | Q302 | 8-729-230-49 | TRANSISTOR 2SC2712-YG | |
| C324 | 1-164-004-11 | CERAMIC CHIP 0.1uF | 10% 25V | Q303 | 8-729-230-49 | TRANSISTOR 2SC2712-YG | |
| C325 | 1-164-004-11 | CERAMIC CHIP 0.1uF | 10% 25V | Q304 | 8-729-230-49 | TRANSISTOR 2SC2712-YG | |
| C326 | 1-124-434-00 | ELECT 220uF | 20% 4V | Q305 | 8-729-230-49 | TRANSISTOR 2SC2712-YG | |
| C327 | 1-124-434-00 | ELECT 220uF | 20% 4V | Q306 | 8-729-920-31 | TRANSISTOR DTC343TK | |
| C328 | 1-124-434-00 | ELECT 220uF | 20% 4V | Q307 | 8-729-230-49 | TRANSISTOR 2SC2712-YG | |
| C329 | 1-164-346-11 | CERAMIC CHIP 1uF | 16V | Q308 | 8-729-040-78 | TRANSISTOR DTA124GKA-T146 | |
| C330 | 1-163-009-11 | CERAMIC CHIP 0.001uF | 10% 50V | Q309 | 8-729-027-36 | TRANSISTOR DTA143XKA-T146 | |
| C331 | 1-163-224-11 | CERAMIC CHIP 7PF | 0.25PF 50V | | | < RESISTOR > | |
| C332 | 1-163-113-00 | CERAMIC CHIP 68PF | 5% 50V | R301 | 1-216-121-00 | RES,CHIP 1M | 5% 1/10W |
| C333 | 1-163-021-00 | CERAMIC CHIP 0.01uF | 10% 50V | R302 | 1-216-101-00 | METAL CHIP 150K | 5% 1/10W |
| C334 | 1-124-233-11 | ELECT 10uF | 20% 16V | R303 | 1-216-081-00 | METAL CHIP 22K | 5% 1/10W |
| C335 | 1-163-245-11 | CERAMIC CHIP 56PF | 5% 50V | R304 | 1-216-061-00 | METAL CHIP 3.3K | 5% 1/10W |
| C336 | 1-163-245-11 | CERAMIC CHIP 56PF | 5% 50V | R305 | 1-216-103-00 | RES,CHIP 180K | 5% 1/10W |
| C337 | 1-163-021-00 | CERAMIC CHIP 0.01uF | 10% 50V | R306 | 1-216-113-00 | METAL CHIP 470K | 5% 1/10W |
| C338 | 1-163-037-11 | CERAMIC CHIP 0.022uF | 10% 50V | R307 | 1-216-097-00 | RES,CHIP 100K | 5% 1/10W |
| C339 | 1-164-489-11 | CERAMIC CHIP 0.22uF | 10% 16V | R308 | 1-216-073-00 | METAL CHIP 10K | 5% 1/10W |
| C340 | 1-164-346-11 | CERAMIC CHIP 1uF | 16V | R309 | 1-216-089-00 | RES,CHIP 47K | 5% 1/10W |
| C341 | 1-164-161-11 | CERAMIC CHIP 2200PF | 5% 50V | R310 | 1-216-041-00 | METAL CHIP 470 | 5% 1/10W |
| C350 | 1-163-021-00 | CERAMIC CHIP 0.01uF | 10% 50V | R311 | 1-216-049-11 | RES,CHIP 1K | 5% 1/10W |
| | | < CERAMIC FILTER > | | R312 | 1-216-113-00 | METAL CHIP 470K | 5% 1/10W |
| CF301 | 1-577-588-11 | FILTER, CERAMIC | | R313 | 1-216-061-00 | METAL CHIP 3.3K | 5% 1/10W |
| CF302 | 1-567-163-11 | FILTER, CERAMIC | | R314 | 1-216-051-00 | RES,CHIP 1.2K | 5% 1/10W |
| | | < DIODE > | | R315 | 1-216-067-00 | METAL CHIP 5.6K | 5% 1/10W |
| D301 | 8-719-045-99 | DIODE RD2.2M-T1B | | R316 | 1-216-061-00 | METAL CHIP 3.3K | 5% 1/10W |
| D302 | 8-719-002-81 | DIODE 1T363 | | R317 | 1-216-061-00 | METAL CHIP 3.3K | 5% 1/10W |
| D303 | 8-719-066-69 | LED BR2434D (POWER) | | R318 | 1-216-067-00 | METAL CHIP 5.6K | 5% 1/10W |
| | | < IC > | | R319 | 1-216-061-00 | METAL CHIP 3.3K | 5% 1/10W |
| IC301 | 8-752-066-93 | IC CXA1611N-T4 | | R320 | 1-216-097-00 | RES,CHIP 100K | 5% 1/10W |
| IC302 | 8-759-802-75 | IC LA4533M | | R321 | 1-216-093-00 | METAL CHIP 68K | 5% 1/10W |
| IC303 | 8-759-195-02 | IC TC7S86F-TE85L | | R322 | 1-216-093-00 | METAL CHIP 68K | 5% 1/10W |
| IC304 | 8-759-096-87 | IC TC7WU04FU(TE12R) | | R323 | 1-216-125-00 | METAL CHIP 1.5M | 5% 1/10W |
| | | < SHORT > | | R324 | 1-216-025-00 | RES,CHIP 100 | 5% 1/10W |
| JR301 | 1-216-296-00 | SHORT | 0 | R325 | 1-216-057-00 | METAL CHIP 2.2K | 5% 1/10W |
| JR302 | 1-216-296-00 | SHORT | 0 | R326 | 1-216-061-00 | METAL CHIP 3.3K | 5% 1/10W |
| JR303 | 1-216-296-00 | SHORT | 0 | R327 | 1-216-025-00 | RES,CHIP 100 | 5% 1/10W |
| JR304 | 1-216-296-00 | SHORT | 0 | R328 | 1-216-077-00 | METAL CHIP 15K | 5% 1/10W |
| JR305 | 1-216-296-00 | SHORT | 0 | R329 | 1-216-001-00 | METAL CHIP 10 | 5% 1/10W |
| JR306 | 1-216-295-00 | SHORT | 0 | R330 | 1-216-001-00 | METAL CHIP 10 | 5% 1/10W |
| JR308 | 1-216-295-00 | SHORT | 0 | R331 | 1-216-097-00 | RES,CHIP 100K | 5% 1/10W |
| JR309 | 1-216-295-00 | SHORT | 0 | R334 | 1-216-097-00 | RES,CHIP 100K | 5% 1/10W |
| JR310 | 1-216-295-00 | SHORT | 0 | R335 | 1-216-029-00 | METAL CHIP 150 | 5% 1/10W |
| | | | | R342 | 1-216-062-11 | RES,CHIP 3.6K | 5% 1/10W |
| | | | | R345 | 1-216-089-11 | METAL CHIP 47K | 5% 1/10W |

| Ref. No. | Part No. | Description | | | Remark |
|----------|--------------|-------------|------|----|--------|
| R348 | 1-216-069-00 | METAL CHIP | 6.8K | 5% | 1/10W |
| R349 | 1-216-001-00 | METAL CHIP | 10 | 5% | 1/10W |
| R350 | 1-216-053-00 | METAL CHIP | 1.5K | 5% | 1/10W |

< VARIABLE RESISTOR >

| | | |
|-------|--------------|--------------------------------|
| RV301 | 1-223-968-11 | RES, VAR, CARBON 20K/20K (VOL) |
| RV302 | 1-225-641-11 | RES, VAR, CARBON 10K (TUNING) |
| RV303 | 1-238-857-11 | RES, ADJ, CERMET 22K |

* 1-670-527-11 SW BOARD

< SWITCH >

| | | |
|-----|--------------|------------------------------|
| SW1 | 1-572-467-61 | SWITCH, PUSH (1 KEY) (POWER) |
|-----|--------------|------------------------------|

MISCELLANEOUS

| | | |
|-------|--------------|---------------|
| MDD01 | 1-505-117-21 | DRIVER (L-CH) |
| MDD02 | 1-505-117-21 | DRIVER (R-CH) |

Free Manuals Download Website

<http://myh66.com>

<http://usermanuals.us>

<http://www.somanuals.com>

<http://www.4manuals.cc>

<http://www.manual-lib.com>

<http://www.404manual.com>

<http://www.luxmanual.com>

<http://aubethermostatmanual.com>

Golf course search by state

<http://golfingnear.com>

Email search by domain

<http://emailbydomain.com>

Auto manuals search

<http://auto.somanuals.com>

TV manuals search

<http://tv.somanuals.com>