

High End Residential In-Ground Basketball System Owners Manual

1-800-Spalding

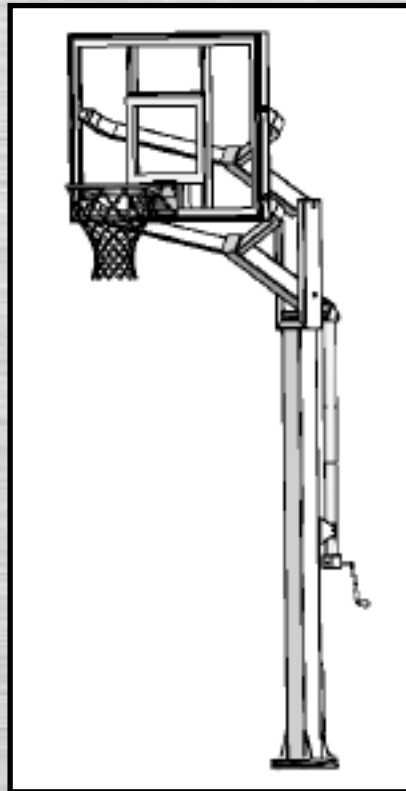

Adult Assembly Required.

This manual, accompanied by sales receipt, should be saved and kept on hand as a convenient reference, as it contains important information about your model.

**Write Model Number
From Box Here:**



WARNING!

**READ AND UNDERSTAND OPERATOR'S
MANUAL BEFORE USING THIS UNIT.**

**FAILURE TO FOLLOW OPERATING
INSTRUCTIONS COULD RESULT IN
INJURY OR DAMAGE TO PROPERTY.**

Toll-Free Customer Service Number for U.S: **1-800-334-9111** Australia Customer Service: **1300 367 582**
Internet Address: **<http://www.spalding.com>** **www.spalding.com.au**

SAFETY INSTRUCTIONS

FAILURE TO FOLLOW THESE SAFETY INSTRUCTIONS MAY RESULT IN SERIOUS INJURY, PROPERTY DAMAGE AND WILL VOID WARRANTY.

Owner must ensure that all players know and follow these rules for safe operation of the system.

To ensure safety, do not attempt to assemble this system without following the instructions carefully. Proper and complete assembly, use and supervision is essential for proper operation and to reduce the risk of accident or injury. A high probability of serious injury exists if this system is not installed, maintained, and operated properly. Check entire box and inside all packing material for parts and/or additional instructional material. **Before beginning assembly, read the instructions and identify parts using the hardware identifier and parts list in this document.**

- If using a ladder during assembly, use extreme caution.
- Three (3) capable adults are recommended for this operation.
- Before digging, contact utility company to locate underground power cables, gas, and water lines. Ensure there are no overhead power lines within 20 ft. (7 m) radius of pole location.
- Climate, corrosion, excessive use, or misuse could result in system failure.
- If technical assistance is required, contact Customer Service.
- Minimum operational height is 6'6" (1.98 m) to the bottom of backboard.
- This equipment is intended for home recreational use only and NOT excessive competitive play.
- Read and understand the warning label affixed to pole.
- The life of your basketball pole depends on many conditions. The climate, placement of the pole, the location of the pole, exposure to corrosives such as pesticides, herbicides or salts are all important.
- Adult supervision is recommended when adjusting height.
- Serious injury could occur if teeth/face come in contact with backboard, net, or rim.

Most injuries are caused by misuse and/or not following instructions. Use caution when using this system.

For more information on assembly, placement, proper use and maintenance, visit The American Basketball Council website at <http://www.smarthoops.com>.



WARNING

Read and understand warnings listed below before using this product.

Failure to follow these warnings may result in serious injury and/or property damage.

Owner must ensure that all players know and follow these rules for safe operation of the system.

- DO NOT HANG on the rim or any part of the system including backboard, support braces or net.
- During play, especially when performing dunk type activities, keep player's face away from the backboard, rim and net. Serious injury could occur if teeth/face come in contact with backboard, rim or net.
- Do not slide, climb, shake or play on base and/or pole.
- When adjusting height or moving system, keep hands and fingers away from moving parts.
- Do not allow children to move or adjust system.
- During play, do not wear jewelry (rings, watches, necklaces, etc.). Objects may entangle in net.
- Keep organic material away from pole base. Grass, litter, etc. could cause corrosion and/or deterioration.
- Check pole system for signs of corrosion (rust, pitting, chipping) and repaint with exterior enamel paint. If rust has penetrated through the steel anywhere, replace pole immediately.
- Check system before each use for proper ballast, loose hardware, excessive wear and signs corrosion and repair before use.
- Check system before each use for instability.
- Never play on damaged equipment.
- Keep pole top covered with cap at all times.
- See instruction manual for proper installation and maintenance.

SPALDING
In the U.S.: 1-800-558-5234
In Canada: 1-800-294-8339
In Australia: 1-300-367-582

RUSSELL









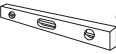

HYDRA-RIB
In the U.S.: 1-800-334-9111

SURE SHOT
In the U.S.: 1-800-558-5234

Trademarks registered in the USA and other countries.
ID#: 58800001 02/12

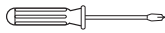
HUFFY SPORTS
In the U.S.: 1-800-558-5234
In Canada: 1-800-284-8339

REQUIRED TOOLS AND MATERIALS:

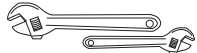
 • 3 Capable Adults  • Carpenter's Level  • 15' Tape Measure  • Shovel & Post Hole Digger  • Wood Board (scrap)	 • (2) Stepladders 8 ft. (2.4 m)  • (1) Utility Knife  • Safety Goggles  • Phillips-Head Screwdriver	<div style="border: 1px solid black; padding: 5px; text-align: center;"> <p>CONCRETE</p> <p>• 1520 LBS. (689 KG.)</p> </div> <p>• Container to Mix</p> 
<p>• (2 each) Wrenches and/or Socket Wrenches and Sockets (Deep-Well Sockets are Recommended).</p> <div style="display: flex; justify-content: space-around; align-items: center;"> <div style="text-align: center;">  <p>1/2" 9/16" 3/4" 15/16"</p> </div> <div style="text-align: center;">  <p>1/2" 9/16" 3/4" 15/16"</p> </div> </div>		<p>• Optional: Large & Small Adjustable Wrenches</p> 

BEFORE YOU START!

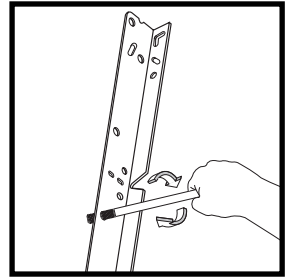
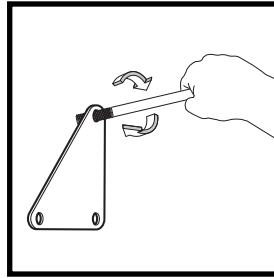
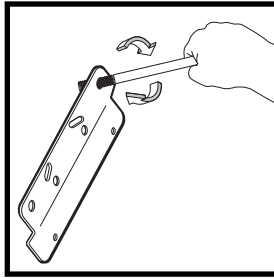
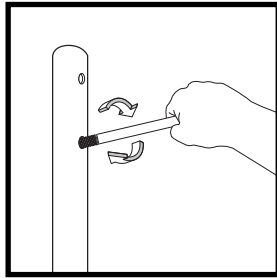

To ensure optimal playability of backboard system, a close tolerance fit between the elevator components and hardware is required. Test-fit large bolts into large holes of elevator tubes, backboard brackets, and triangle plates. Carefully rock them in a circular motion to ream out any excess paint from holes if necessary.

Not all items pictured are included with every model.

NOTICE TO ASSEMBLERS

Adult Assembly Required. Dispose of ALL packaging materials promptly. As with all products, periodically inspect for loose small parts.

ALL basketball systems, including those used for DISPLAYS, MUST be assembled and installed according to instructions. Failure to follow instructions could result in SERIOUS INJURY. It is NOT acceptable to devise a makeshift support system.

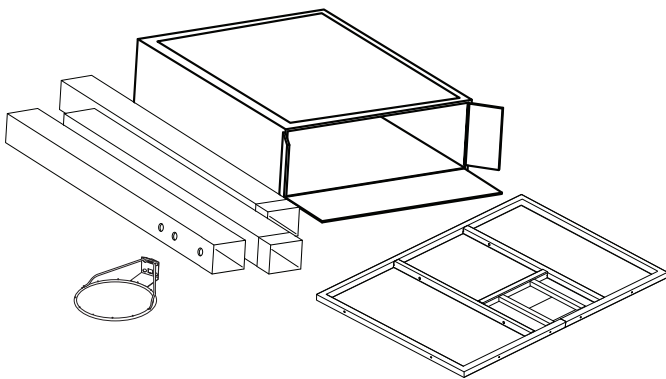

IMPORTANT!

**Remove all contents from boxes.
Be sure to check inside pole sections,
hardware and additional parts are packed inside.**



Questions or Missing Parts?

DON'T go back to the store!

Call TOLL-FREE Customer Service
number listed on the front page!



WARNING!



IF YOUR SYSTEM IS EQUIPPED WITH AN ACRYLIC BACKBOARD, EXAMINE BACKBOARD FOR ANY DAMAGE THAT MAY HAVE OCCURRED DURING SHIPMENT. CRACKS IN THE BACKBOARD COULD RESULT IN SUDDEN BREAKAGE. IF BACKBOARD IS DAMAGED IN ANY WAY PRIOR TO OR AFTER ASSEMBLY, CALL TOLL-FREE NUMBER: U.S. 1-800-334-9111 Internet Address: www.spalding.com

PARTS LIST - See Hardware Identifier

<input checked="" type="checkbox"/>	<u>Item</u>	<u>Qty.</u>	<u>Part No.</u>	<u>Description</u>
<input type="checkbox"/>	1	1	958860C	Pole
<input type="checkbox"/>	2	1	908265	Tube, Ground Anchor, Black
<input type="checkbox"/>	3	1		Rim Assembly
<input type="checkbox"/>	4	1		Net
<input type="checkbox"/>	5	4	203017	Nut, Hex, 3/8-16
<input type="checkbox"/>	6	4	203300	Washer, 3/8 Locking, .380 I.D., .63 O.D.
<input type="checkbox"/>	7	2	250001	Bolt, Hex, Tap, 3/8-16 x 4" Long
<input type="checkbox"/>	8	2*	250002	Bolt, Hex, Tap, 3/8-16 x 2" Long
<input type="checkbox"/>	9	8	265575	Nut, Hex, 5/8-11, Zinc
<input type="checkbox"/>	10	3	204993	Rebar, .5" diameter, 18" Long
<input type="checkbox"/>	11	1	200685	Label, Height Adjustment
<input type="checkbox"/>	12	1	204940	Screw Jack
<input type="checkbox"/>	13	24	204670A	Bushing, Plastic
<input type="checkbox"/>	14	1	80854501	Rod, Threaded Assembly, 5/8-11 x 19.8", Zinc
<input type="checkbox"/>	15	1	204922	Pin, Hitch
<input type="checkbox"/>	16	1		Cover, Rim
<input type="checkbox"/>	17	1	978880C	Yoke, Upper, Center, Pole
<input type="checkbox"/>	18	1	988880C	Yoke, Lower, Center, Pole
<input type="checkbox"/>	19	1		Backboard
<input type="checkbox"/>	20	1	202900	Bolt, Hex, 1/2-13 x 5, Zinc
<input type="checkbox"/>	21	16	202651	Washer, Flat, .053 I.D., 1.08 O.D., Zinc
<input type="checkbox"/>	22	9*	206340	Nut, Lock, Nylon Insert, 1/2-13, Zinc
<input type="checkbox"/>	23	1*	220048	Bolt, Hex Head, 1/2"-13 x 6", Zinc
<input type="checkbox"/>	24	9	200704	Washer, 5/8 Flat, .656 I.D., 1.313 O.D., Zinc
<input type="checkbox"/>	25	4	205830	Bolt, Hex, 1/2-13 x 2.5, Zinc
<input type="checkbox"/>	26	1	215008	Nut, Hex, 5/8-11, Grade 8, Black
<input type="checkbox"/>	27	4*	203309	Washer, Flat, 3/8"
<input type="checkbox"/>	28	3	224728	Bolt, Hex, 1/2-13 x 9.25, Zinc
<input type="checkbox"/>	29	4	204733	Screw, #8, .50 Long
<input type="checkbox"/>	30	2	204735	Height Indicator, Plastic
<input type="checkbox"/>	31	1	204741	Label, Height Indicator, Right
<input type="checkbox"/>	32	1	204742	Label, Height Indicator, Left
<input type="checkbox"/>	33	2*	206311	Spacer, .52 I.D. x .75 O.D. x .5" Long, Plastic
<input type="checkbox"/>	34	1	204923	Pin, Cotter, #8
<input type="checkbox"/>	35	1	204921	Washer, Barrel
<input type="checkbox"/>	36	1	204669	Spacer, .51 ID x .75 OD x 4.00 Long, Metal

* You may have extra parts with this model.

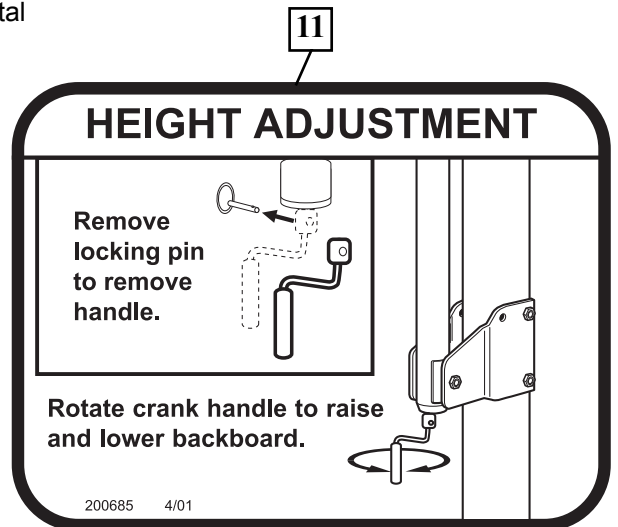

HARDWARE IDENTIFIER (Bolts and Screws)

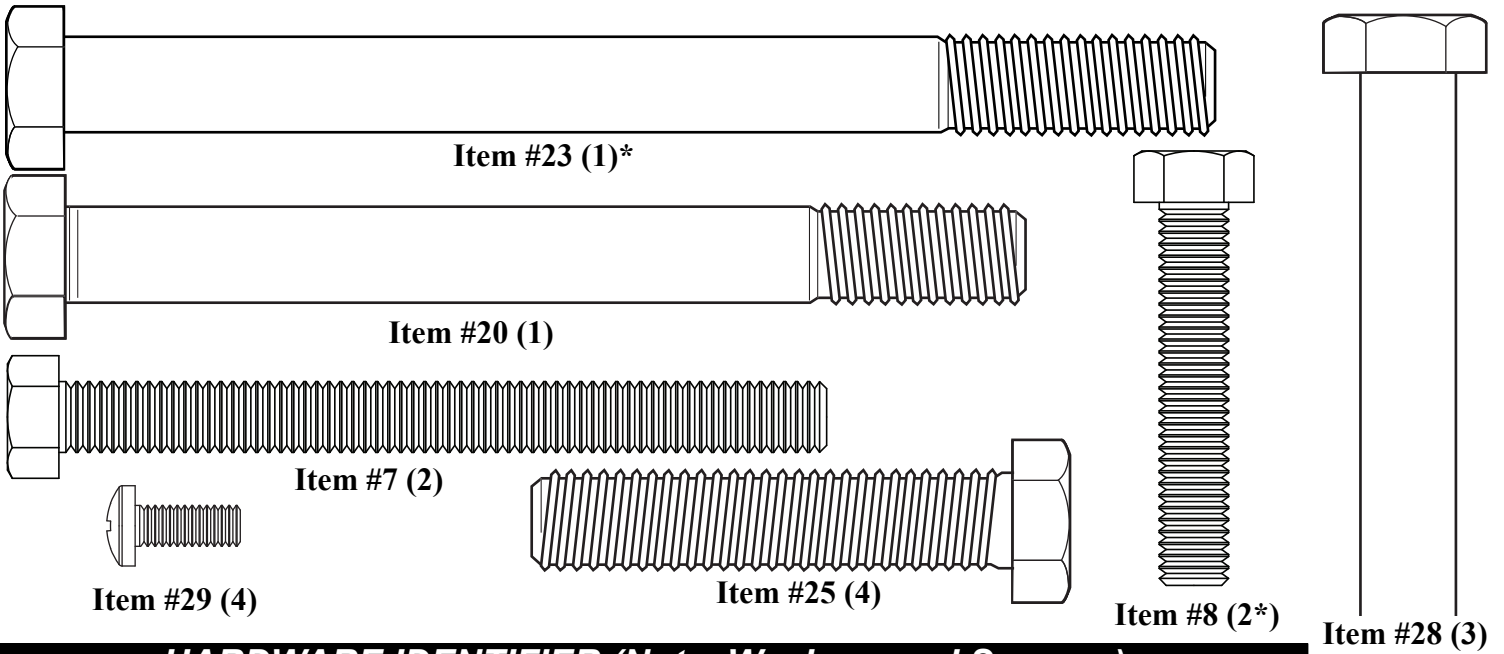

HARDWARE IDENTIFIER (Nuts, Washers and Spacers)

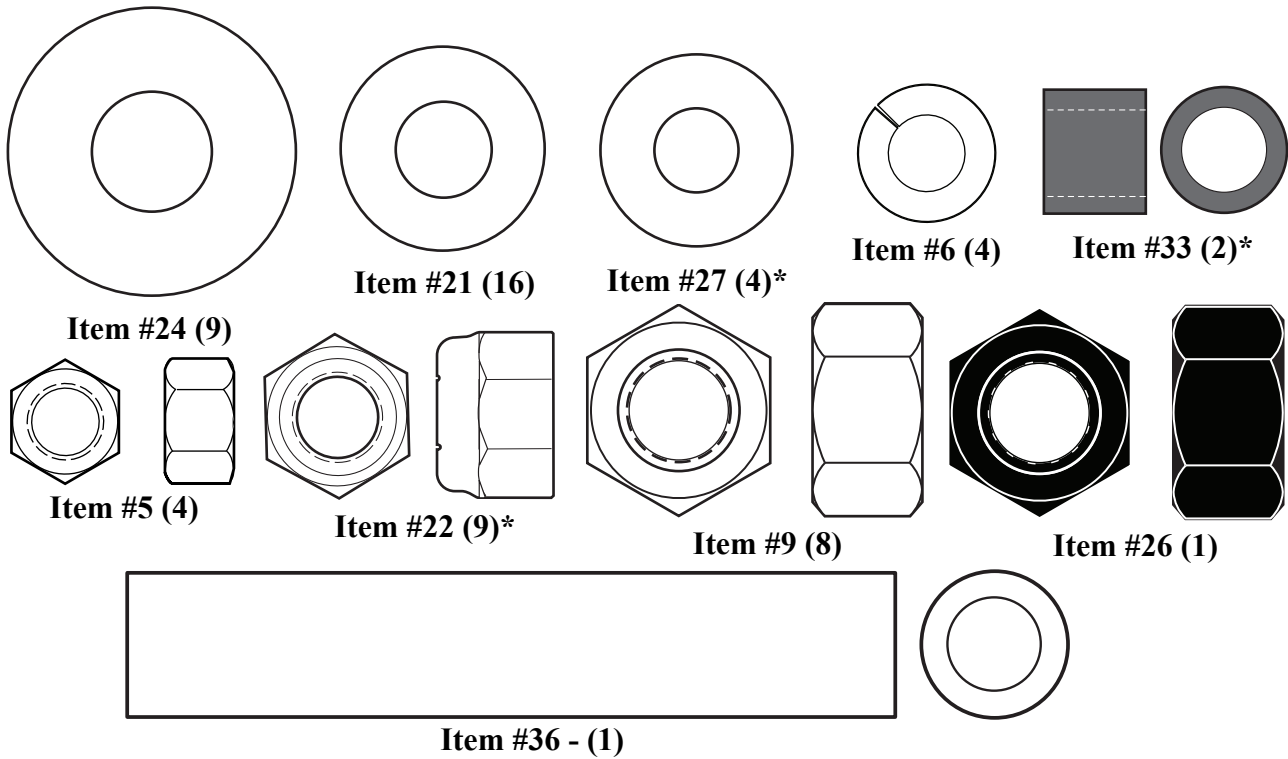

HARDWARE IDENTIFIER (Other - Not Actual Size)

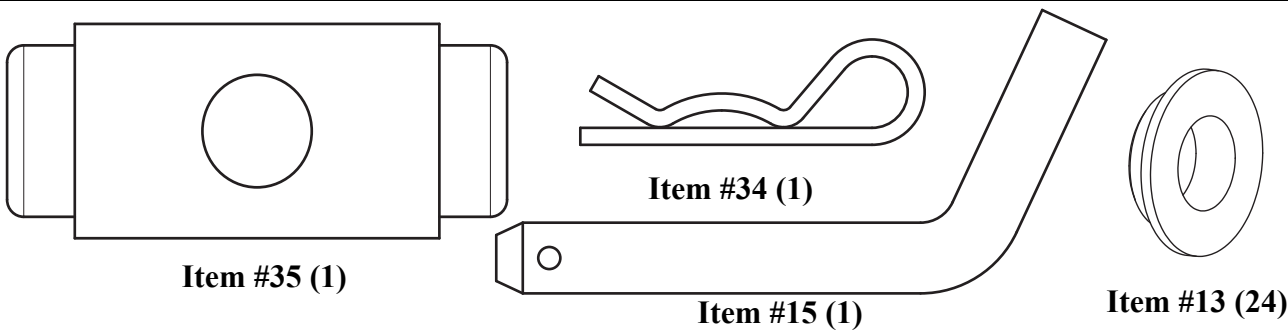

1. Ensure ground is level with playing surface, then dig pole hole.

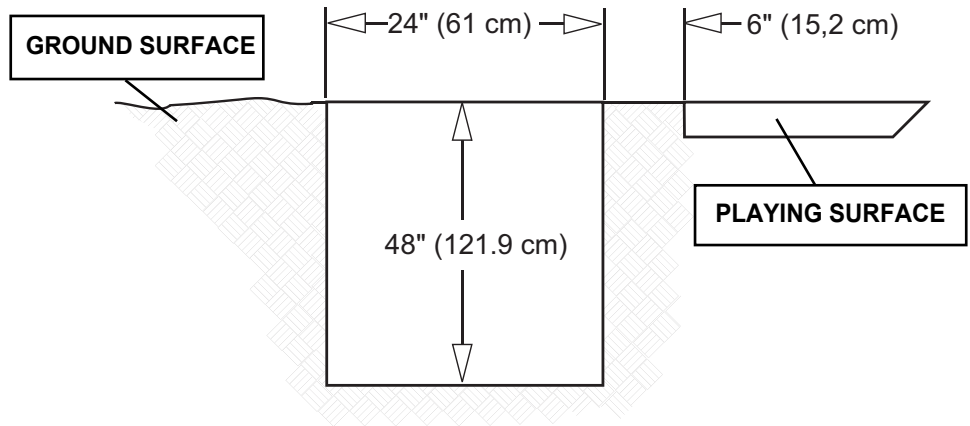
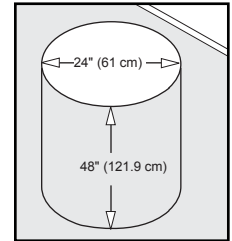
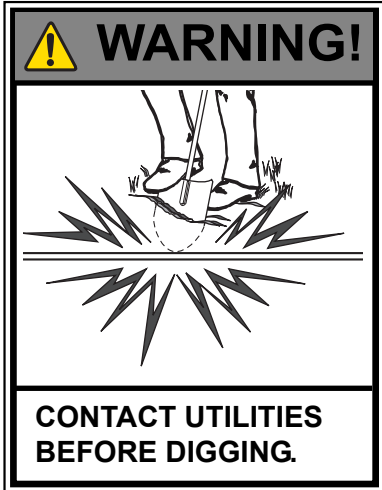

2. Install nuts (9) onto the ground tube (2) bolts as shown.

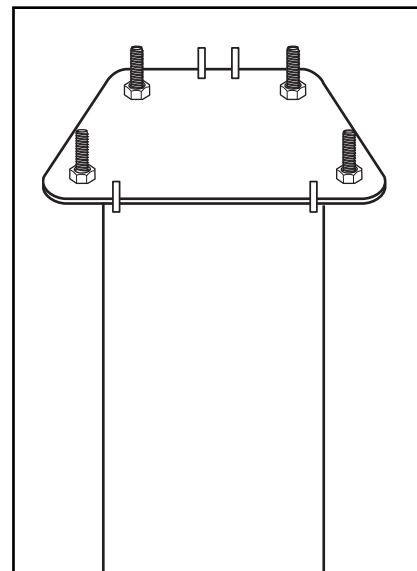
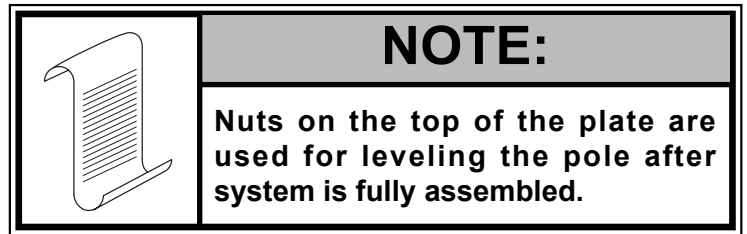
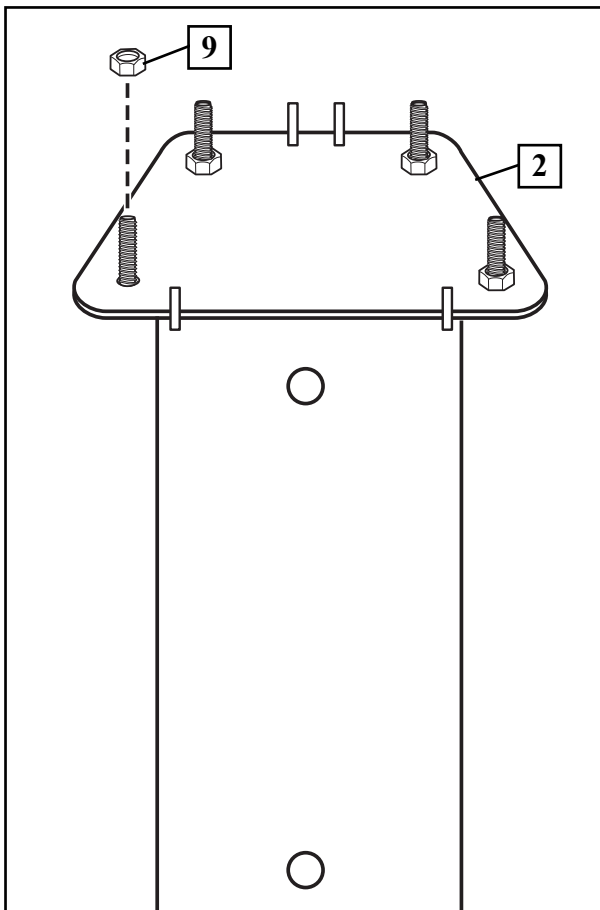

3. Fill hole with concrete. Tamp down concrete to release air pockets and build drainage hill.

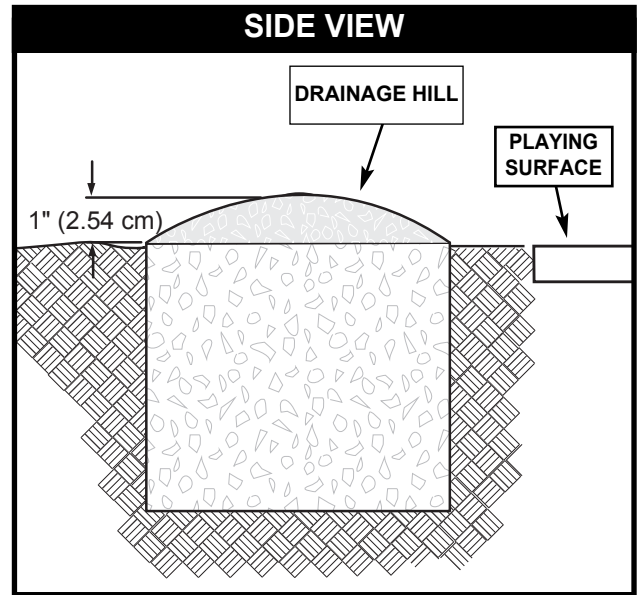
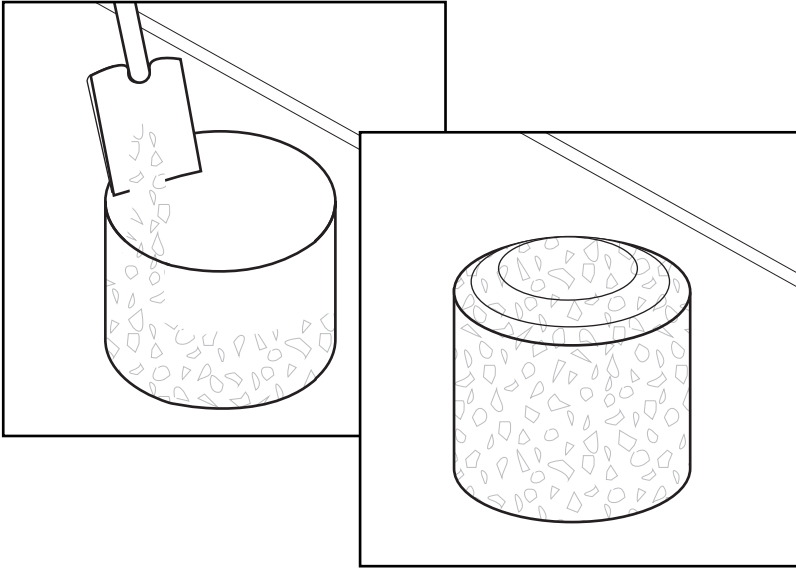

4. Insert rebar (10) through holes in ground tube assembly (2) as shown.

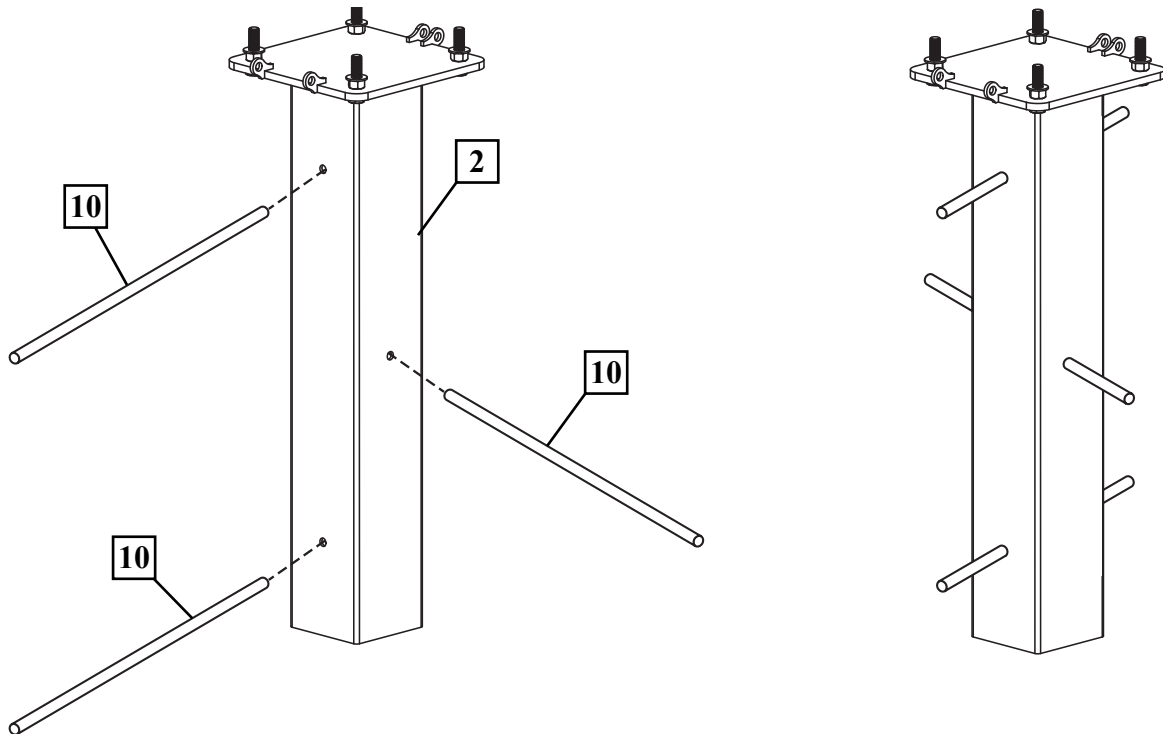

5. Insert ground tube assembly (2) into cement as shown. Move assembly around to release any air pockets in cement, then rest mounting plate on cement drainage hill. Apply some pressure to level mounting plate on top of drainage hill. Level mounting plate and square with playing surface. Clean off any excess cement on mounting plate at this time and place washers (24) on mounting bolts.



IMPORTANT!

NOTE ORIENTATION

Front of mounting plate
must be parallel with
playing surface.

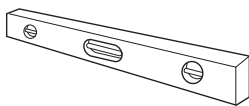
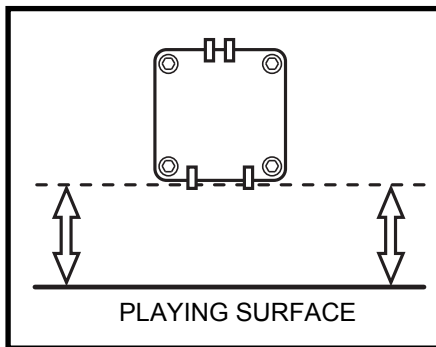

IMPORTANT!

Check leveling of mounting plate
several times with carpenter's
level while concrete is curing.

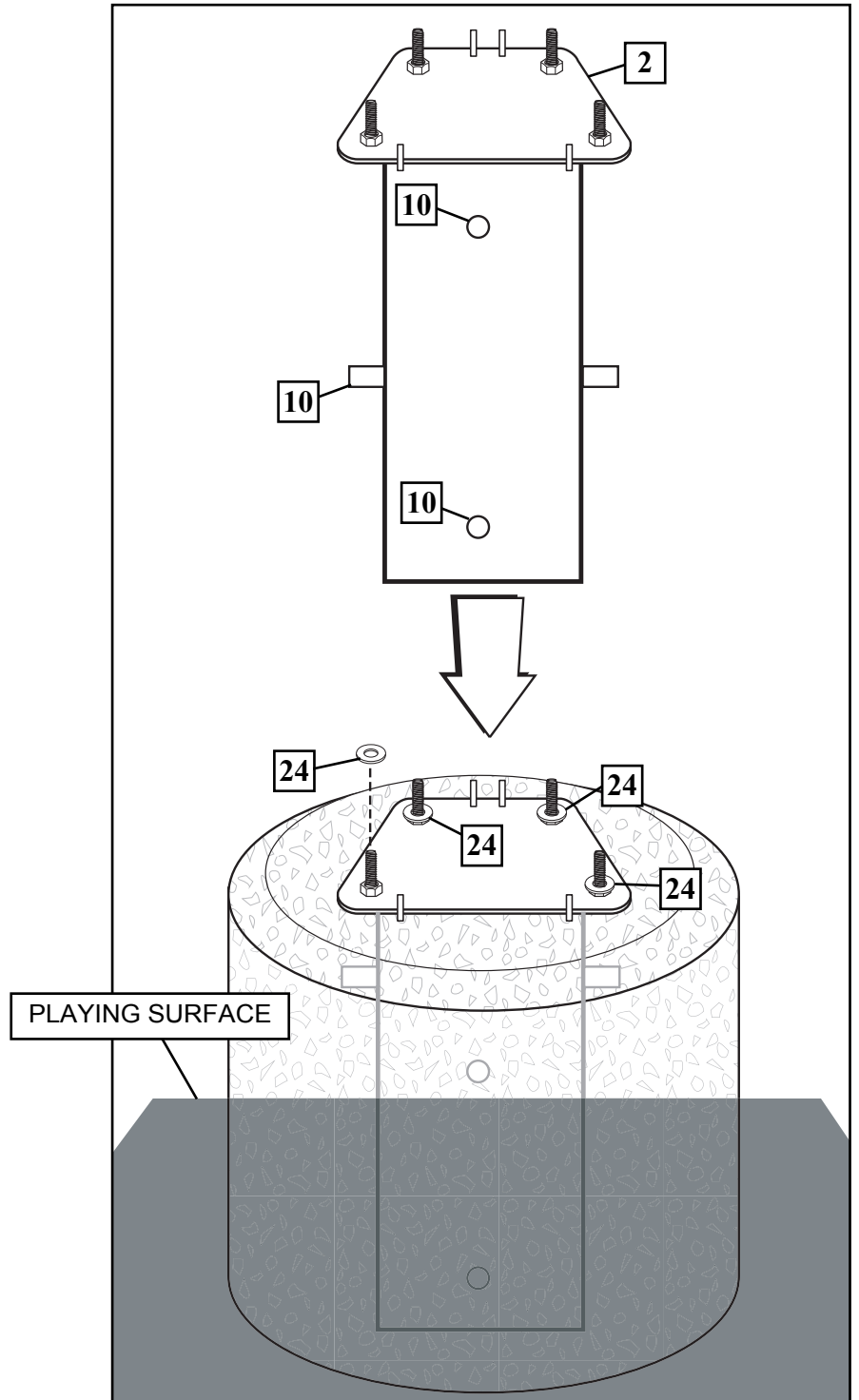

IMPORTANT!: WAIT A MINIMUM OF 72 HOURS BEFORE GOING ON TO NEXT STEP. CONCRETE MUST CURE. ALLOW ADDITIONAL TIME FOR COLD, WET OR HUMID WEATHER.

6. Insert bushings (13) into areas shown.

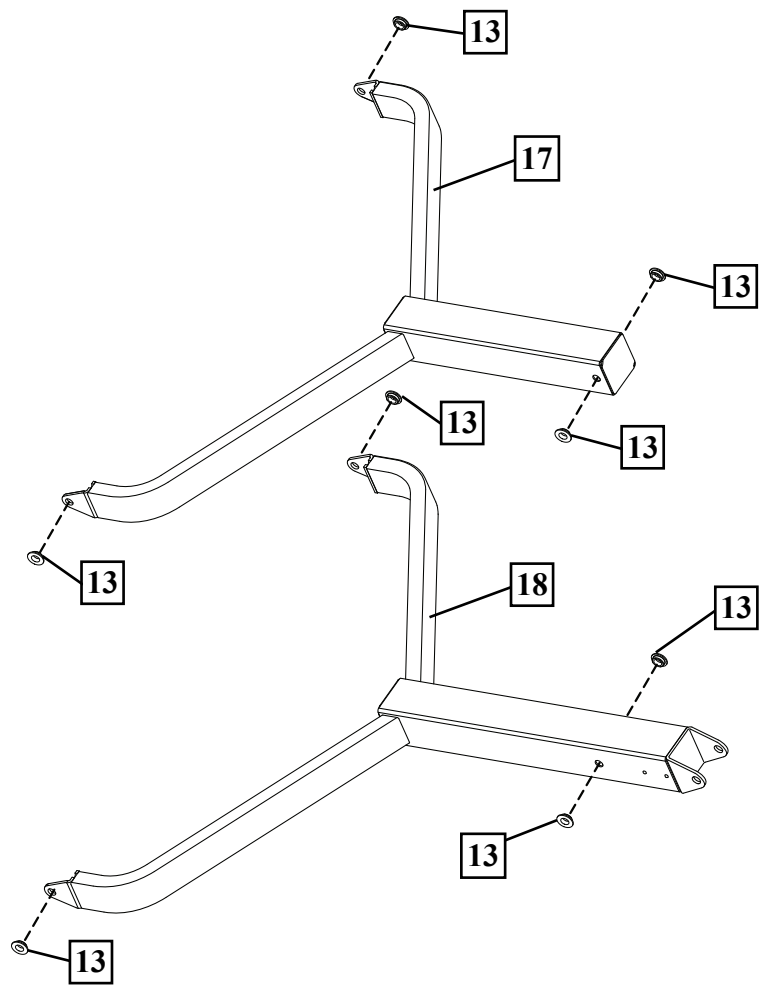
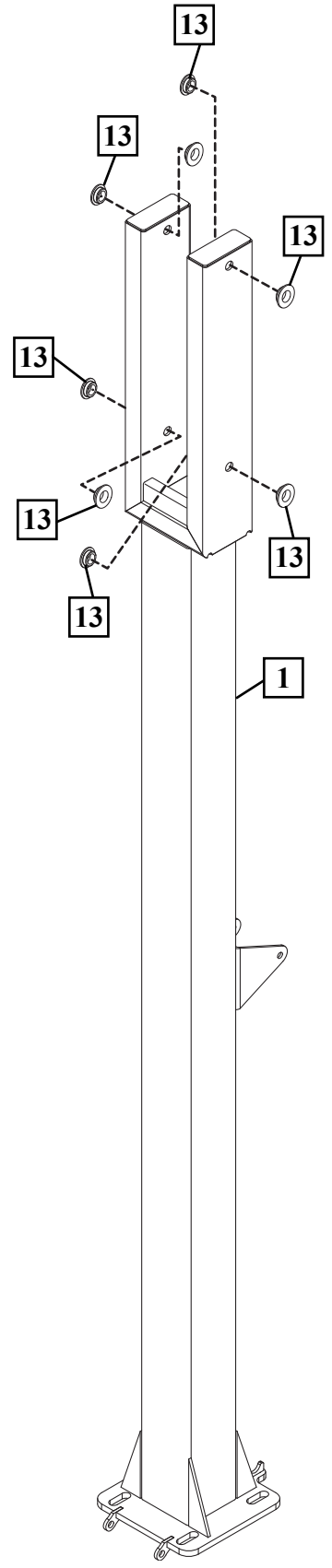
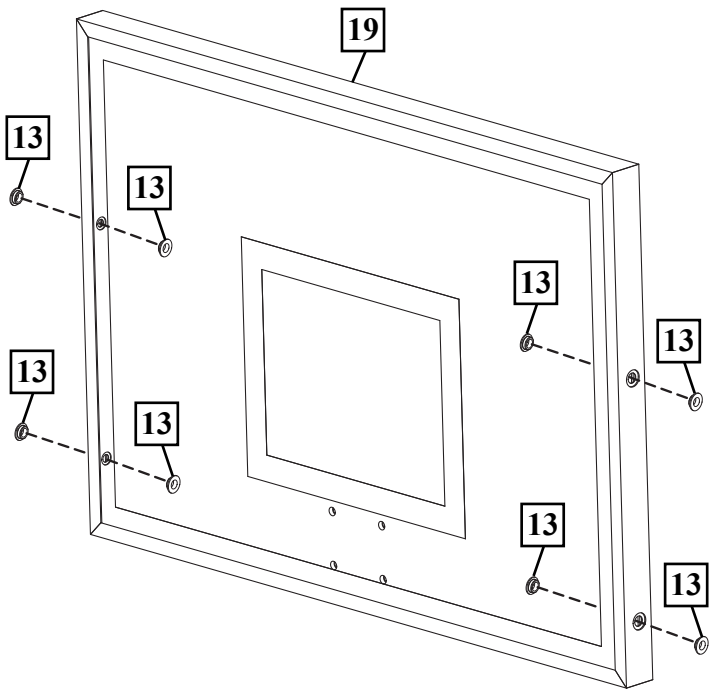

7. Rest top of pole (1) on a piece of scrap wood (not included) and line up holes in pole to holes in mounting plate as shown.

A.

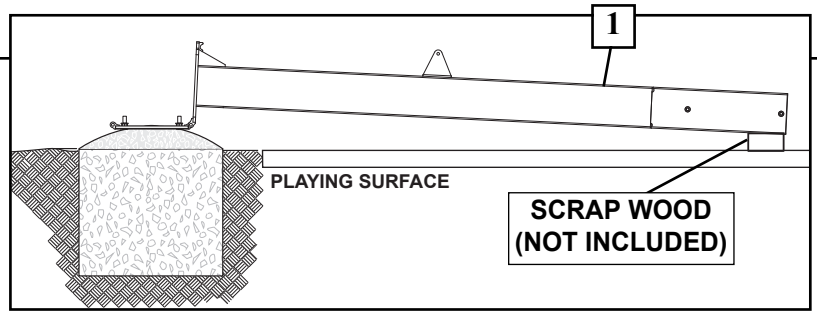

WARNING!

THREE CAPABLE ADULTS
REQUIRED FOR THIS
PROCEDURE. FAILURE
TO FOLLOW THIS
WARNING COULD RESULT
IN SERIOUS INJURY
AND/OR PROPERTY
DAMAGE.

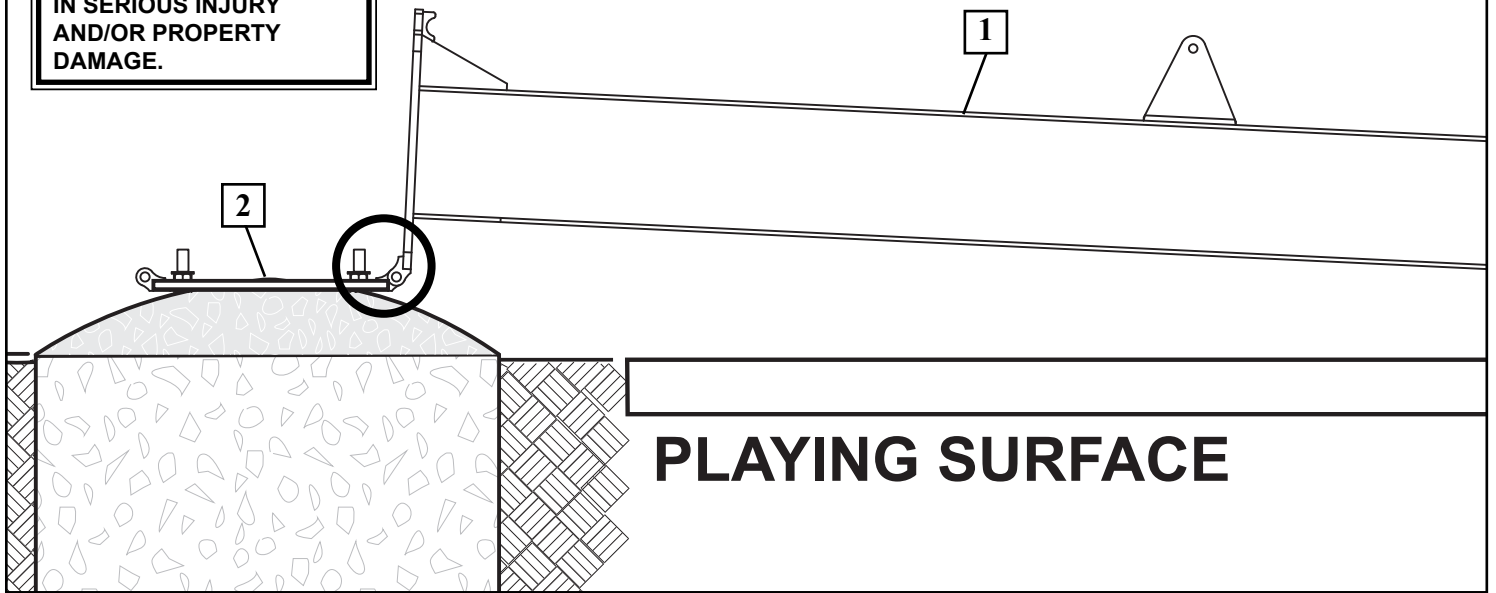

B. Insert bolt (28) through holes in plate and pole (1) and secure with nut (22).

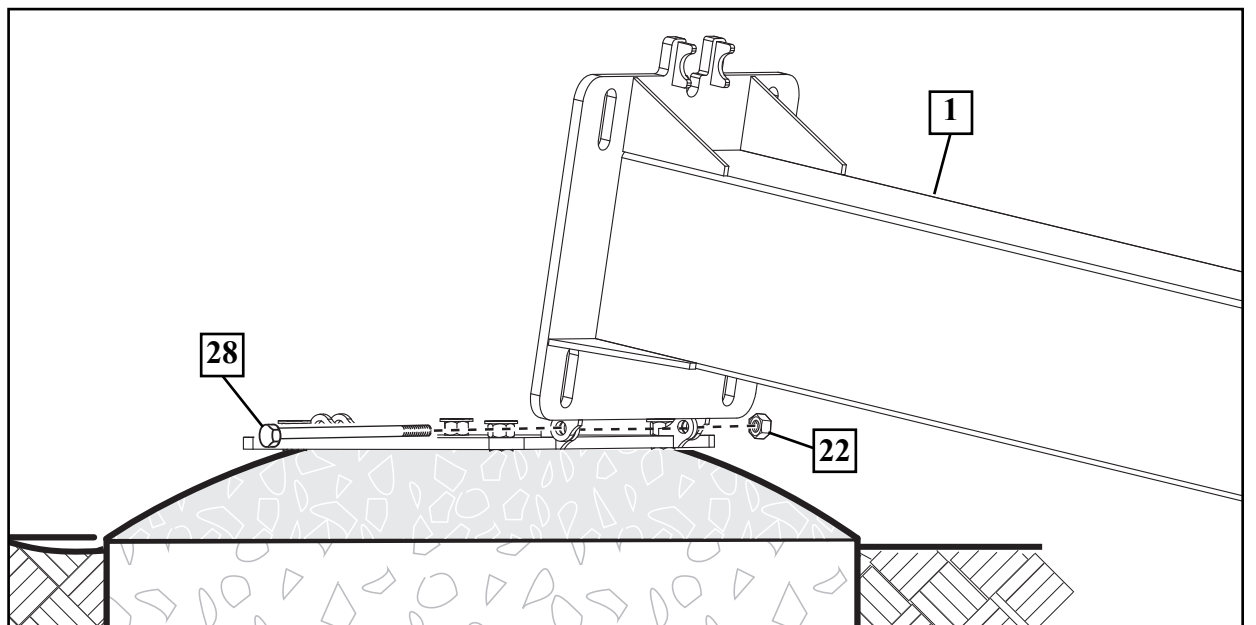

8.

TWO people are required to lift pole into position so that the threaded assembly rod (14) can be installed and secured by the **THIRD** person.

While pole is being supported by **TWO** capable adults, position rod (14) and lock into place with hitch pin (15) and cotter pin (34).

Slide barrel washer (35) onto other end of rod (14) and secure with washer (24) and nut (26). Tighten nut (26) until it is positioned at 3-3/4" from the end of the rod (14) as shown (Figure A).

WARNING!



THREE CAPABLE ADULTS REQUIRED FOR THIS PROCEDURE. FAILURE TO FOLLOW THIS WARNING COULD RESULT IN SERIOUS INJURY AND/OR PROPERTY DAMAGE.

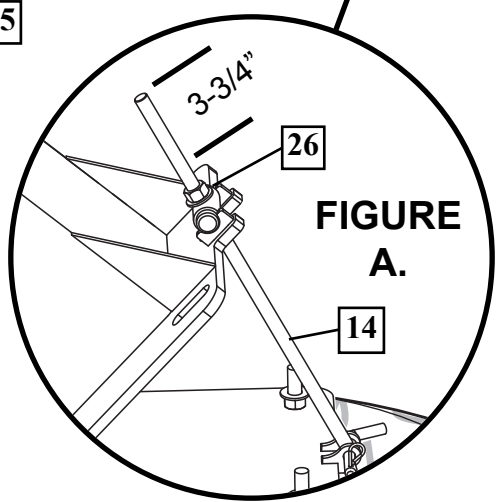
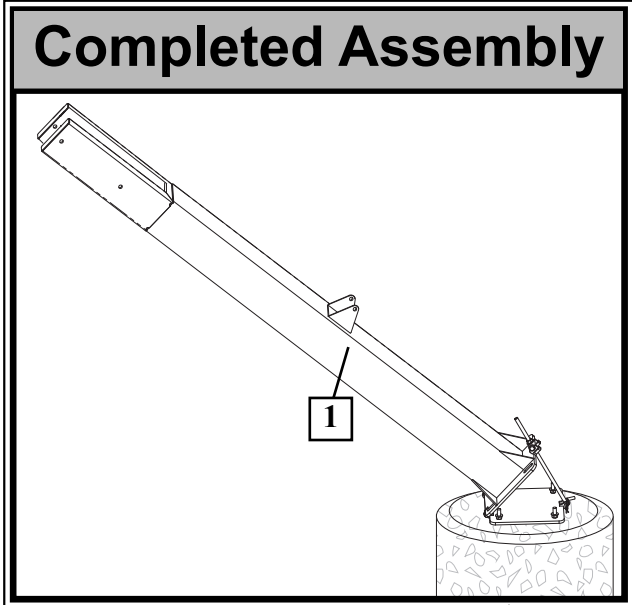
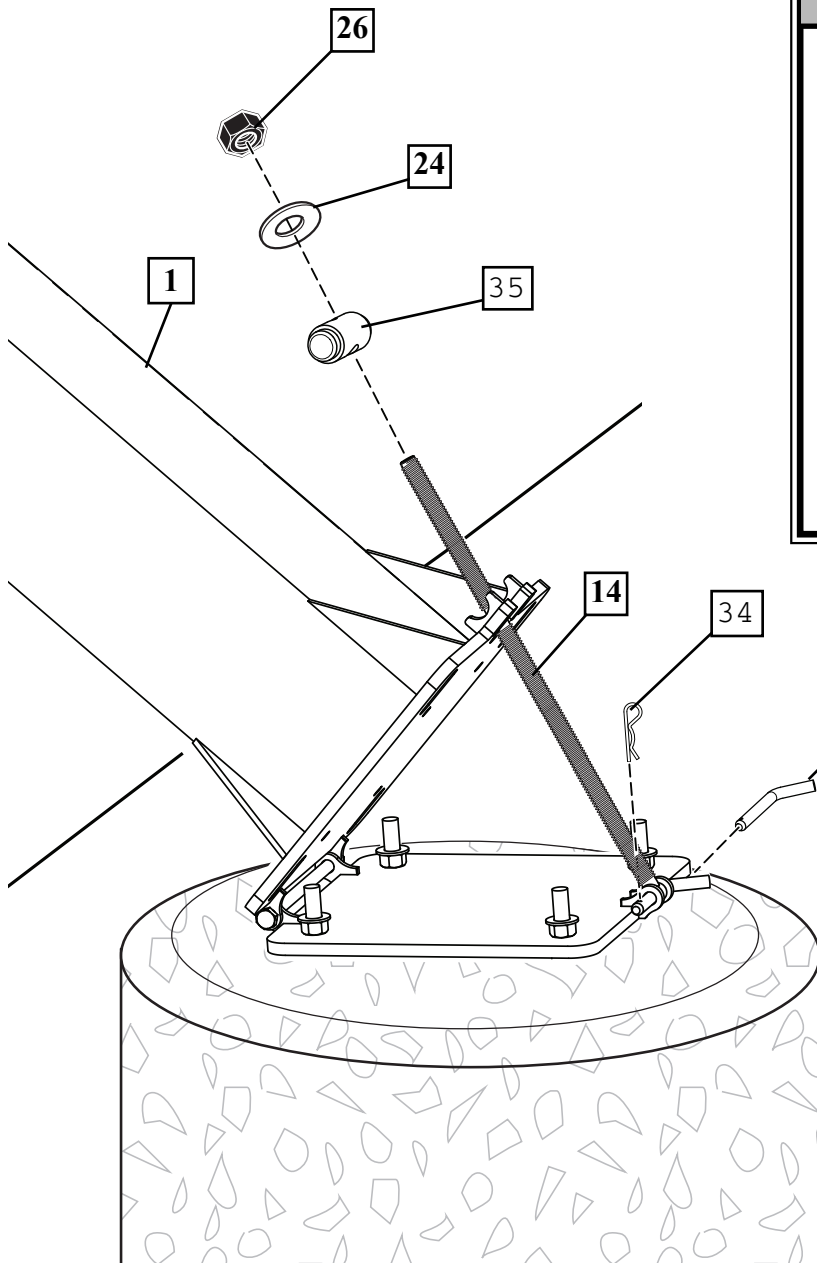
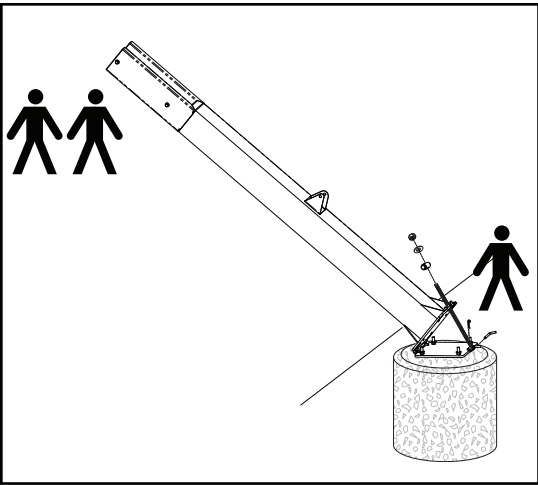

9. While still in forward position, attach both upper and lower yokes (17 & 18) to pole as shown.

WARNING!



THREE CAPABLE ADULTS
REQUIRED FOR THIS
PROCEDURE. FAILURE
TO FOLLOW THIS
WARNING COULD RESULT
IN SERIOUS INJURY
AND/OR PROPERTY
DAMAGE.

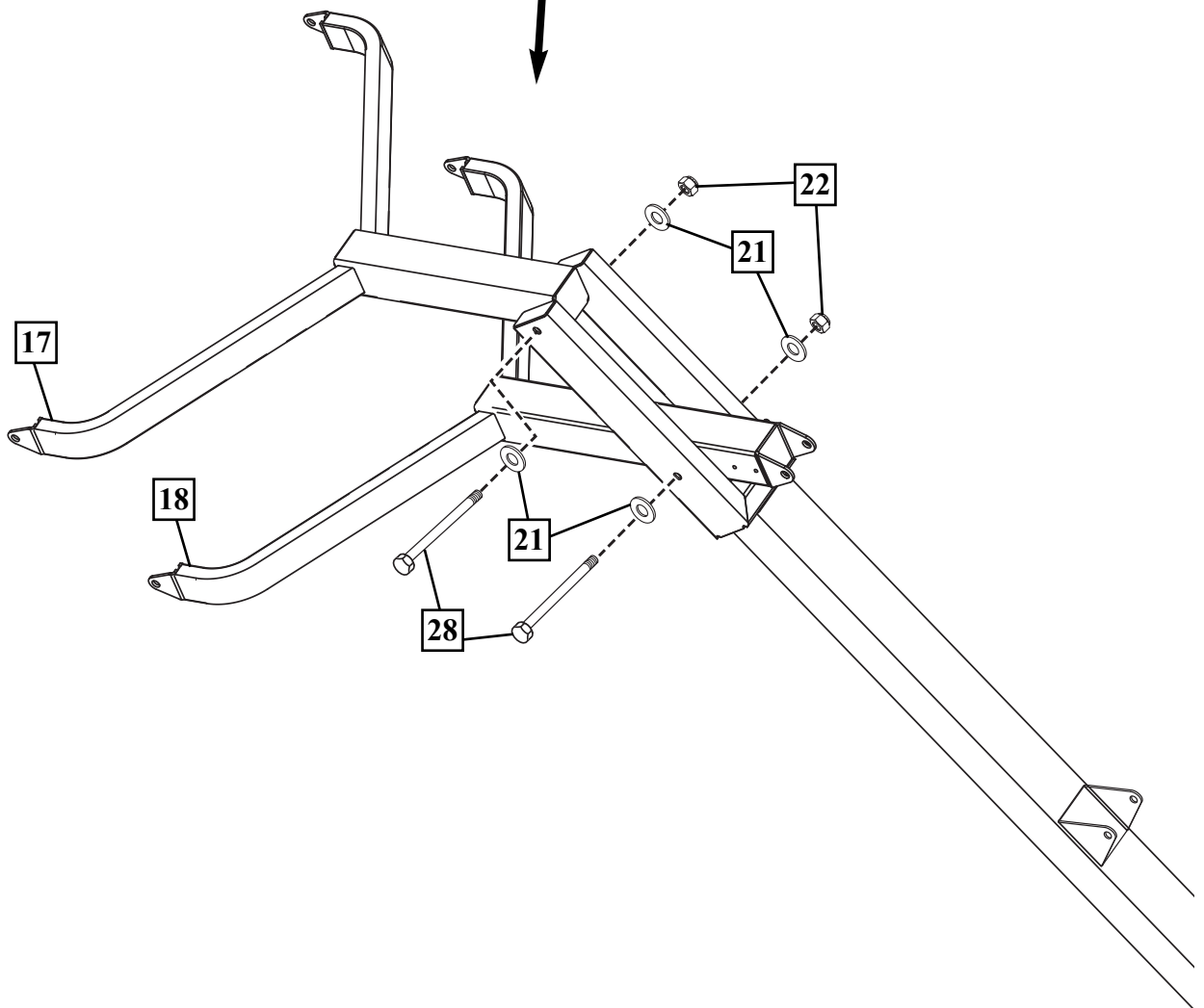
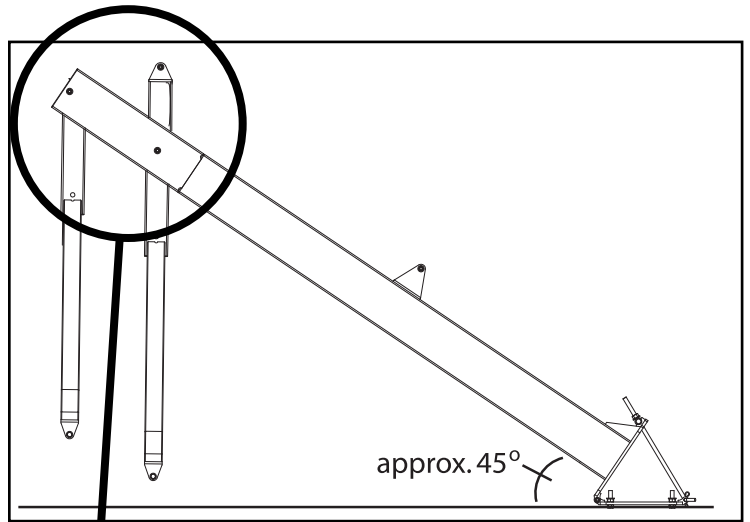

10. Attach elevator adjustment (12) to lower yoke (18).

WARNING!



THREE CAPABLE ADULTS
REQUIRED FOR THIS
PROCEDURE. FAILURE
TO FOLLOW THIS
WARNING COULD RESULT
IN SERIOUS INJURY
AND/OR PROPERTY
DAMAGE.

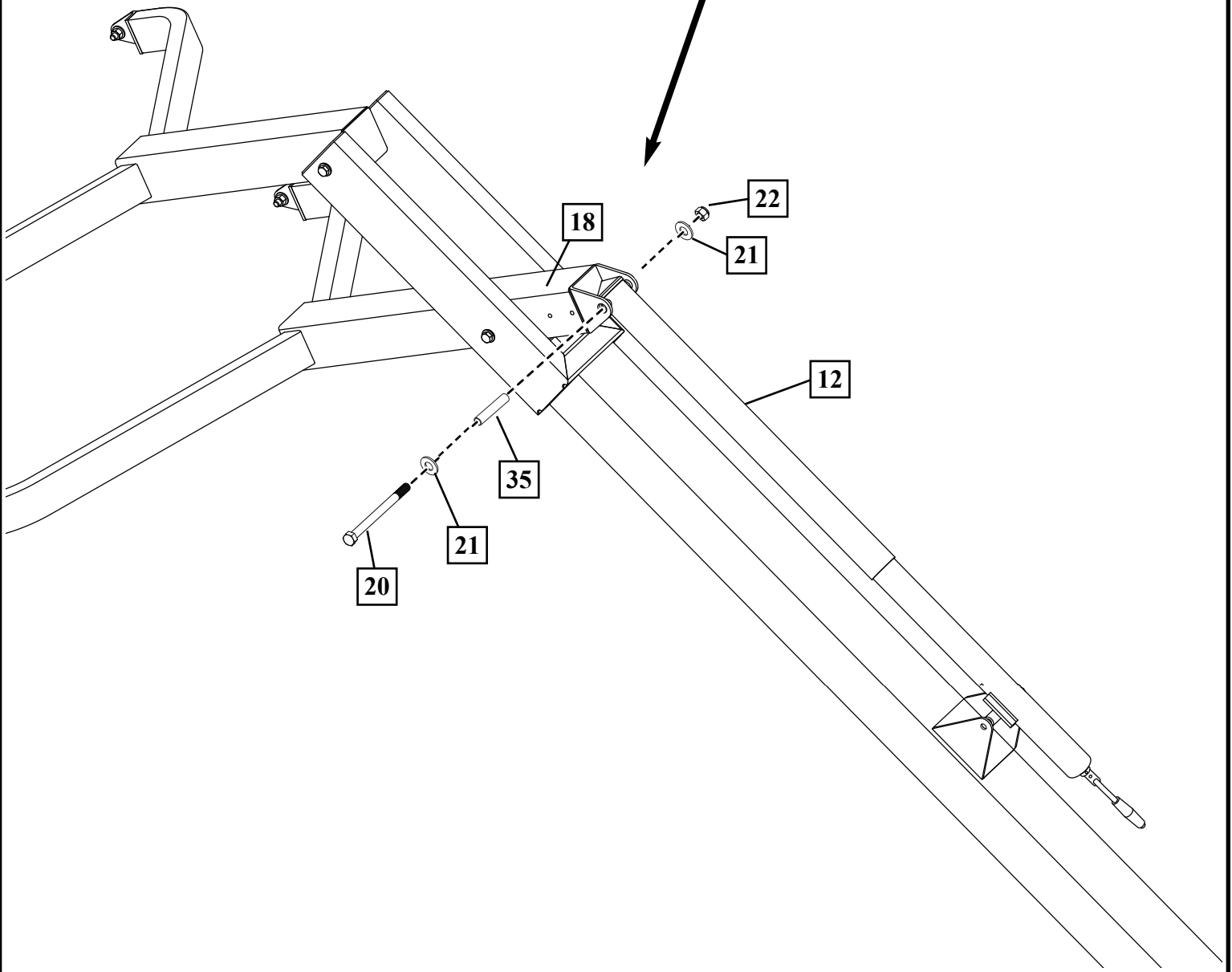
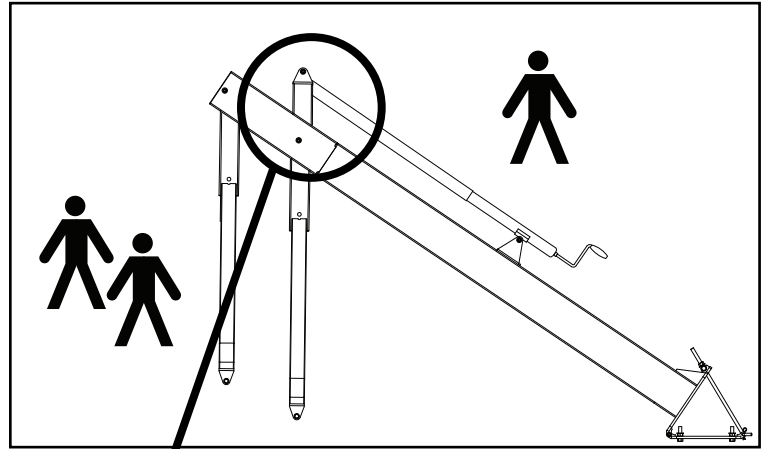

11. Attach elevator adjustment (12) to pole bracket.

WARNING!



THREE CAPABLE ADULTS
REQUIRED FOR THIS
PROCEDURE. FAILURE
TO FOLLOW THIS
WARNING COULD RESULT
IN SERIOUS INJURY
AND/OR PROPERTY
DAMAGE.

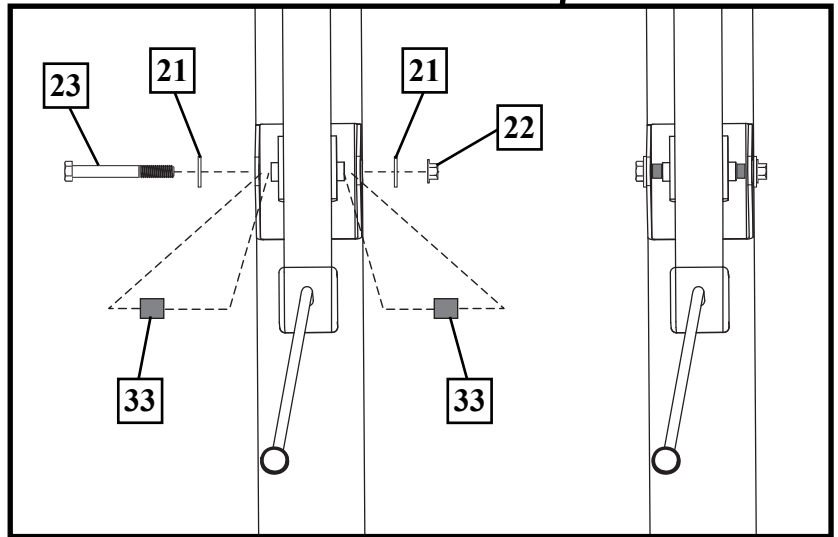
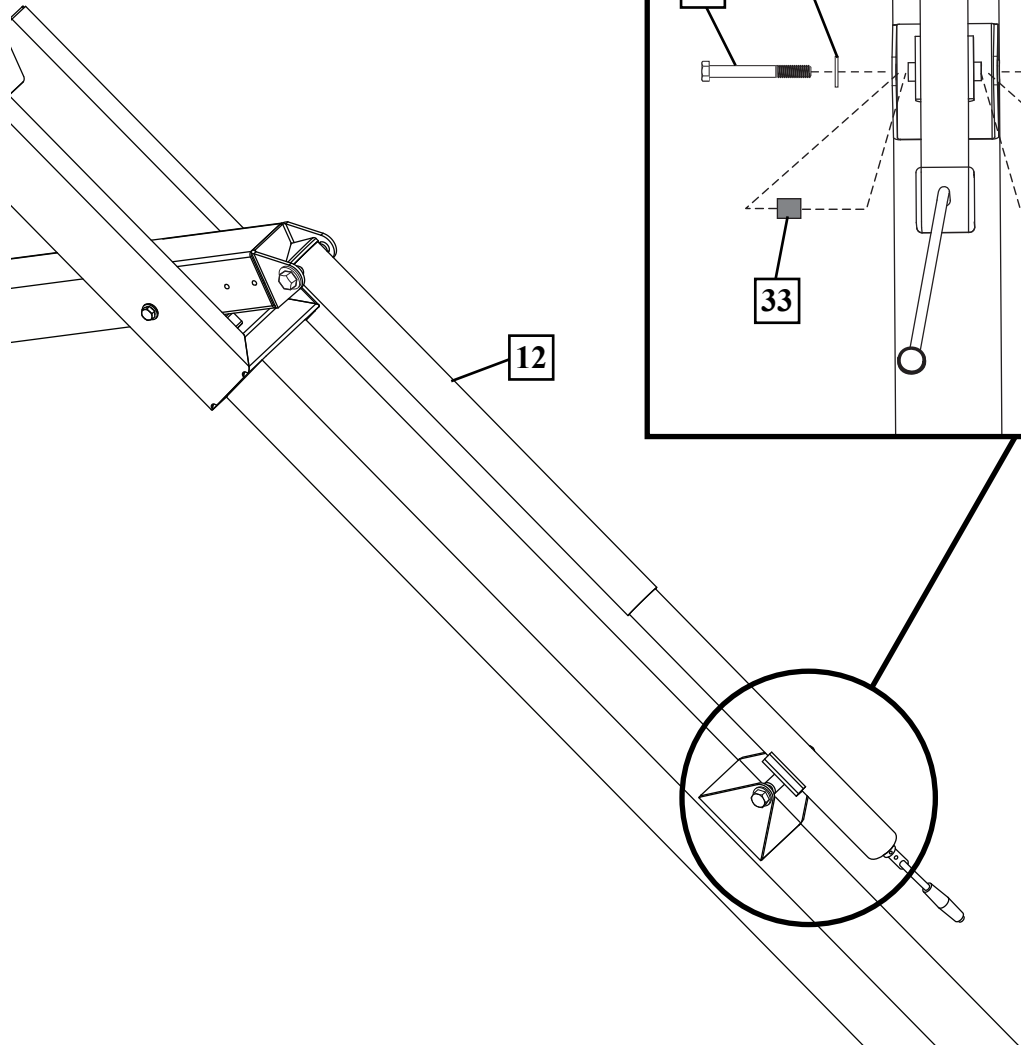
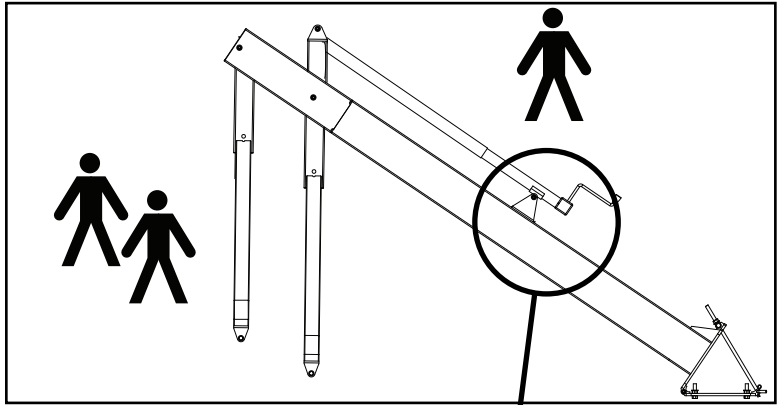

12. Attach backboard (19) to upper and lower yokes (17 & 18).

A. First attach board (19) to upper yoke (17), using TWO people to hold the board and ONE person to attach hardware (FIG. A). Use hardware as shown in FIG. B.

B. Then, hinge board to match up with holes in lower yoke (18), FIG. C, and secure with hardware as shown in FIG. D.

! WARNING!



THREE CAPABLE ADULTS REQUIRED FOR THIS PROCEDURE. FAILURE TO FOLLOW THIS WARNING COULD RESULT IN SERIOUS INJURY AND/OR PROPERTY DAMAGE.

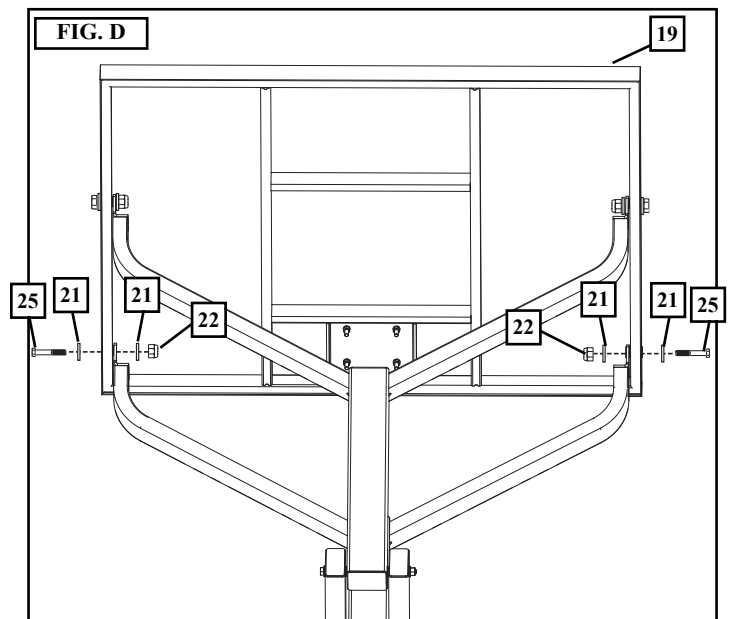
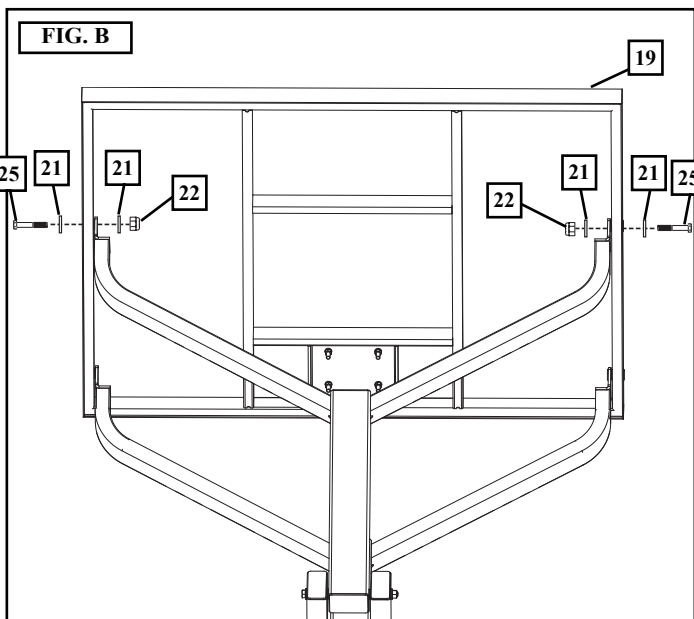
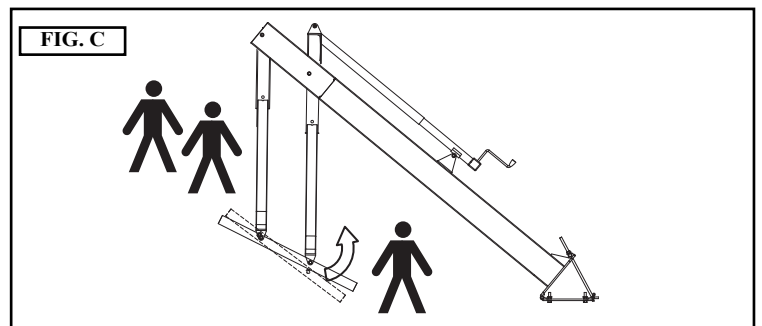
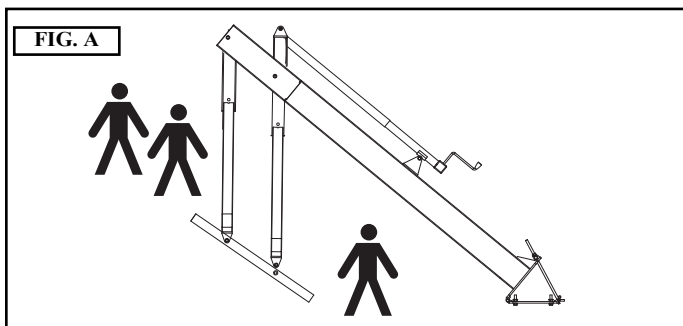

13. Before starting rim assembly, tighten nut (26) until it is positioned 6-3/4" from the end of the rod (14) as shown (Figure A).

Remove rim cover (16), attach rim assembly (3) to backboard (19) and reattach rim cover (16).

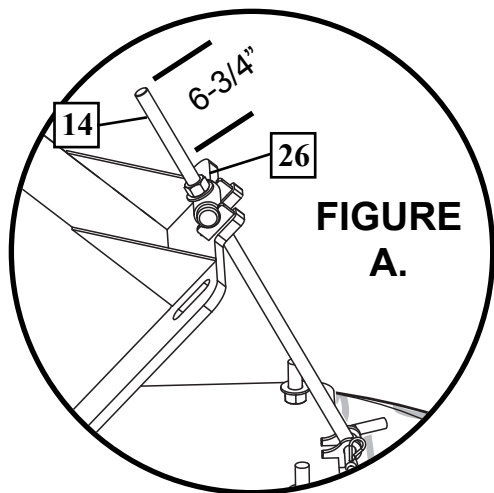

! IMPORTANT! !	
POLYCARBONATE & ACRYLIC BOARDS: Carefully cut and peel protective film away from board prior to attaching rim.	
GLASS BOARDS: DO NOT cut and peel protective film away from back of board prior to attaching rim!	

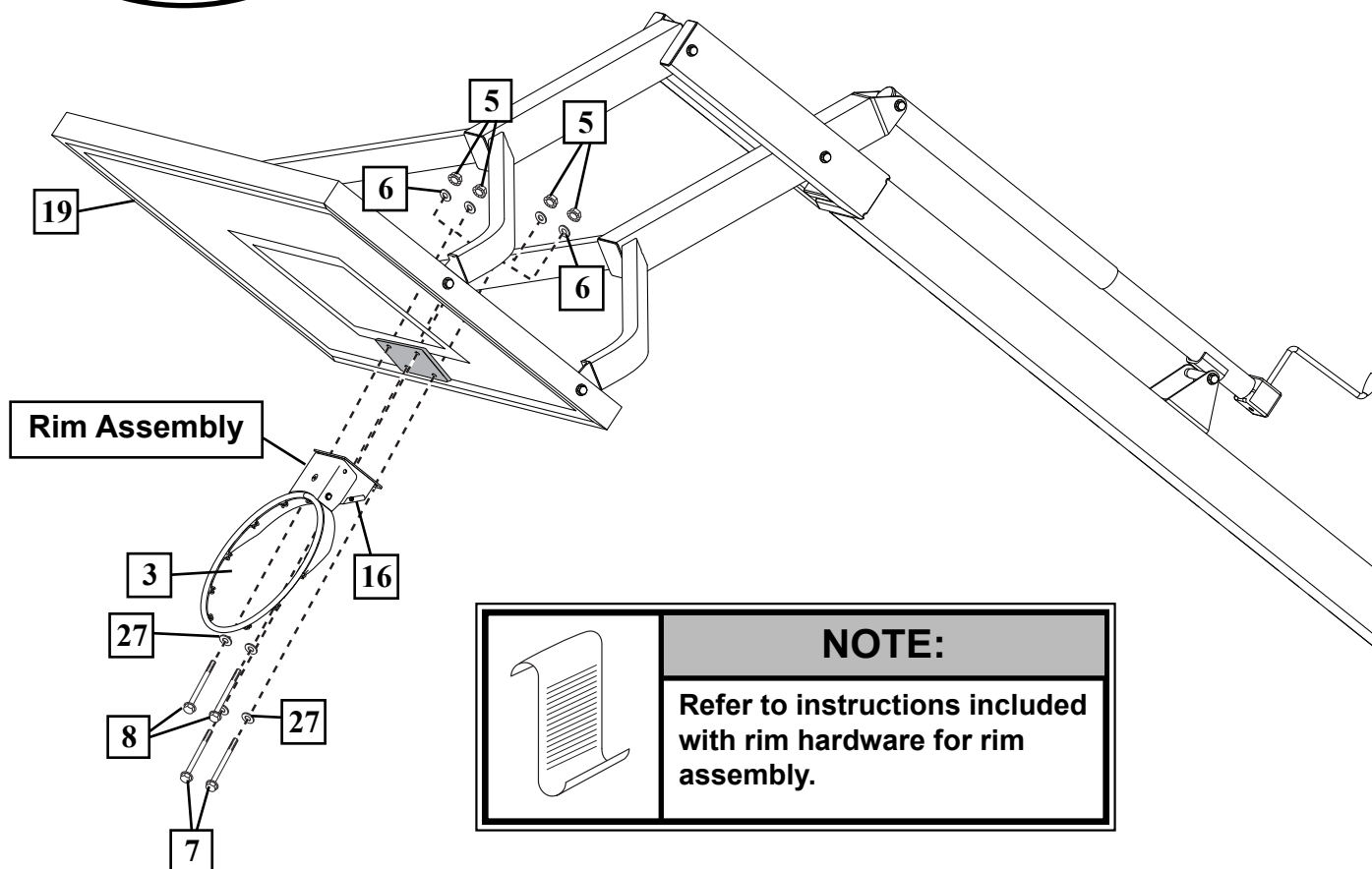

	NOTE:
	Refer to instructions included with rim hardware for rim assembly.

14.

A. Apply height indicator labels (31 & 32) to height indicators (30).

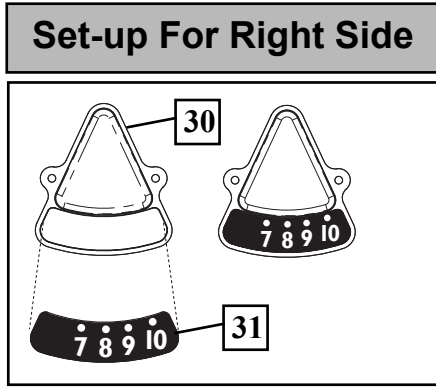
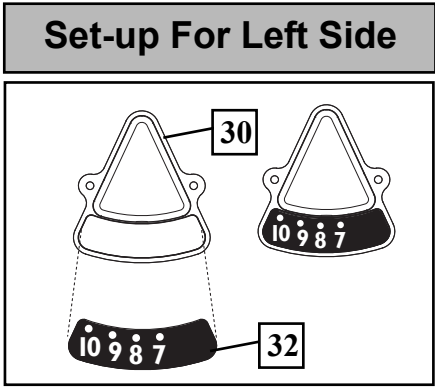

B. Attach height indicator to lower yoke (18) in area shown by turning screws (29) into place with a phillips-head screwdriver.

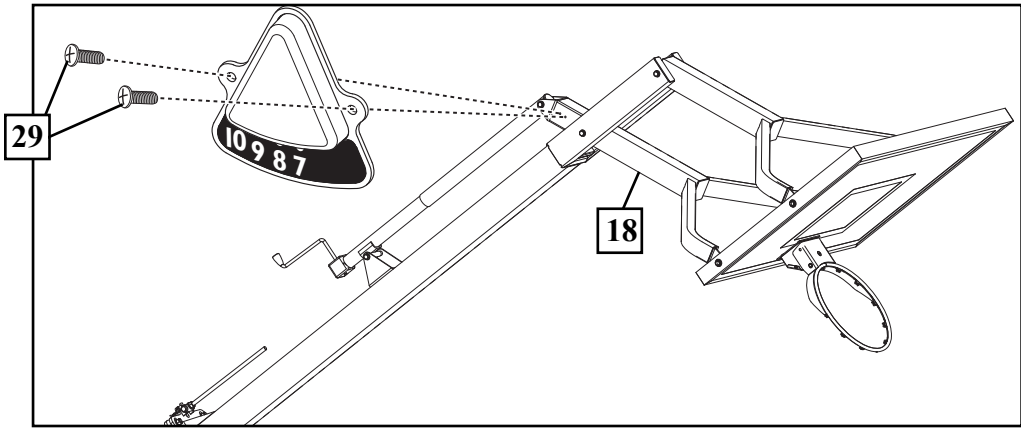

IMPORTANT!

NOTE ORIENTATION OF HEIGHT INDICATORS:
10' MARK SHOULD FACE AWAY FROM BACKBOARD.

C. Attach height indicator to lower yoke (18) in area shown by turning screws (29) into place with a phillips-head screwdriver.

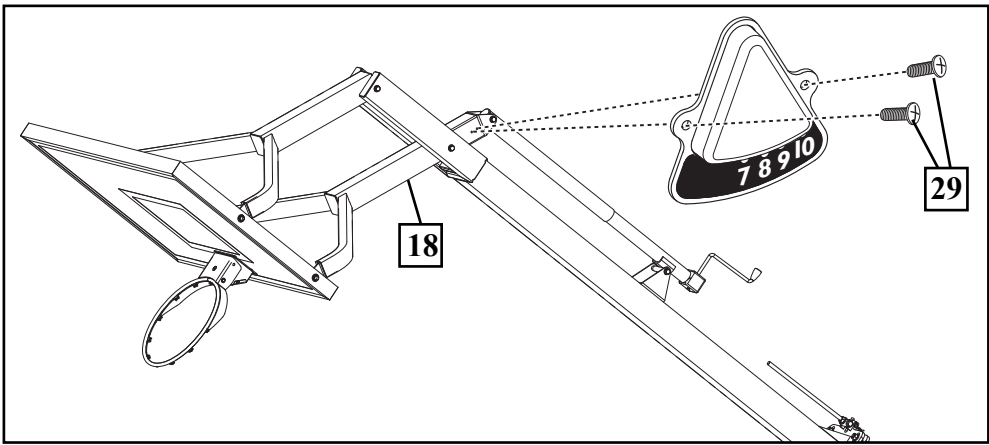

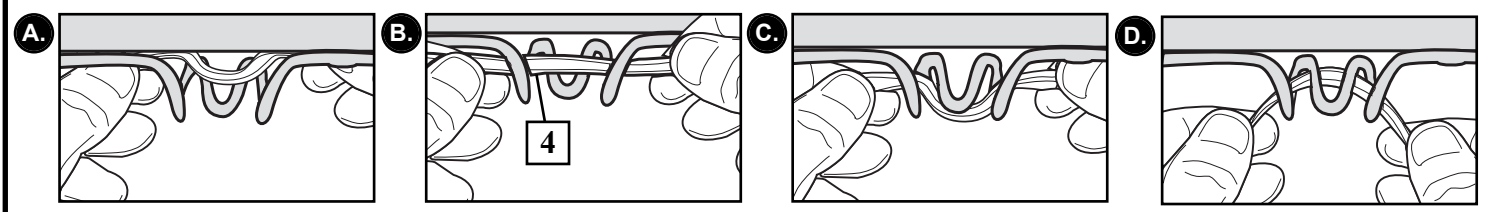

15. Install net (4) to rim as shown.

OUTSIDE VIEW



16. Upright pole (1) by tightening nut (26).
Using 15/16" wrench, turn nut (26) clockwise to begin standing pole upright. Continue to turn nut (26) until pole has come to rest against washers (24) and pole is vertical.

Once pole is in its final position, install washers (24) and nuts (9) onto mounting bolts (19) and fully tighten to secure pole to anchor plate (2).

 WARNING!	
	THREE CAPABLE ADULTS REQUIRED FOR THIS PROCEDURE. TWO PEOPLE ARE REQUIRED TO GUIDE AND SUPPORT THE SYSTEM WHILE THE THIRD PERSON IS TIGHTENING NUT (26) TO RAISE THE SYSTEM UPRIGHT.
	FAILURE TO FOLLOW THIS WARNING COULD RESULT IN SERIOUS INJURY AND/OR PROPERTY DAMAGE.

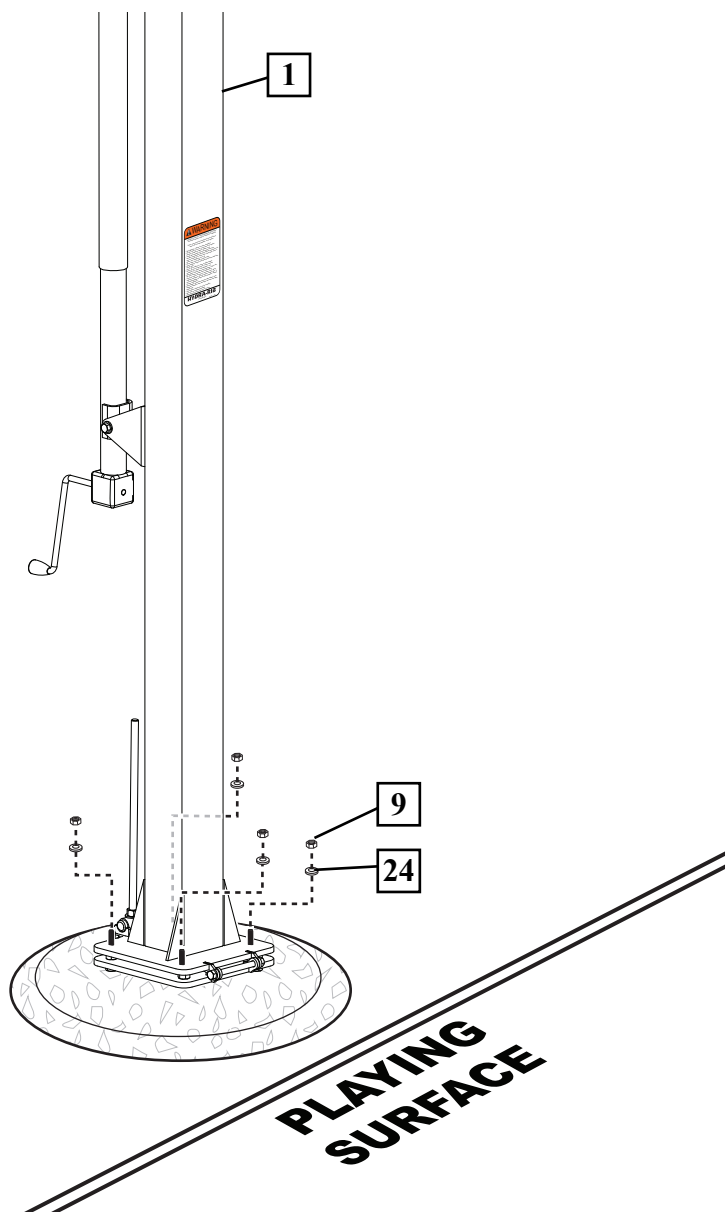
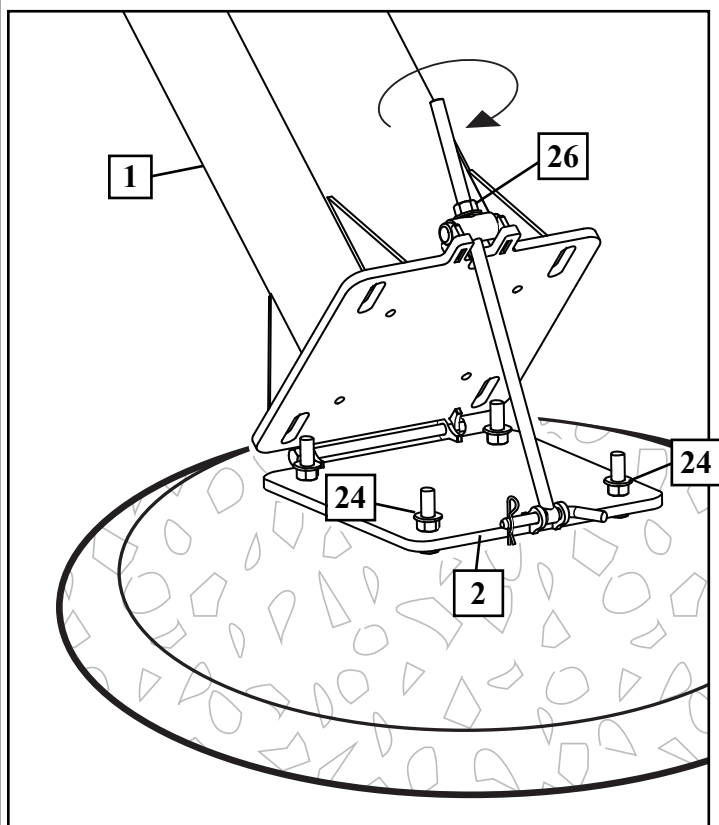
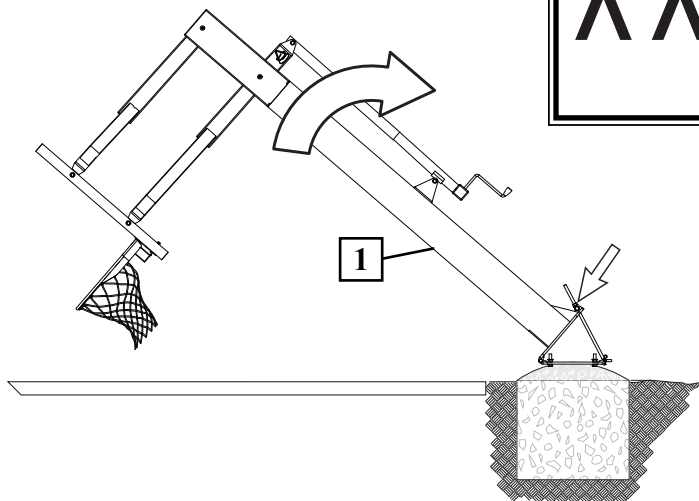

17.

After pole has been secured to the anchor plate loosen nut (26), remove cotter pin (34), and pull out pin (15). This will allow the removal of the threaded assembly rod (14) which is no longer necessary for the remainder of the assembly and installation of system.

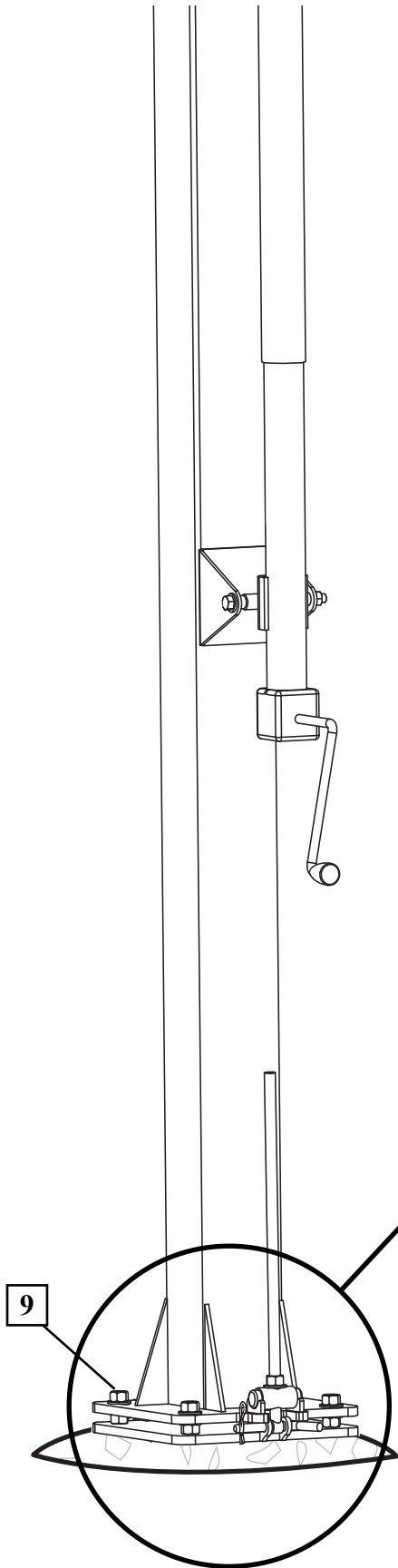

WARNING!

ONLY AFTER THE ANCHOR PLATE HAS BEEN FULLY TIGHTENED: Remove cotter pin (34) and pin (15) to remove threaded assembly rod (14) from anchor plate.

26

24

35

14

34

9

24

15

18.

Check system leveling. Pole (1) should be level in all directions. After system is leveled, completely tighten all nuts (9).

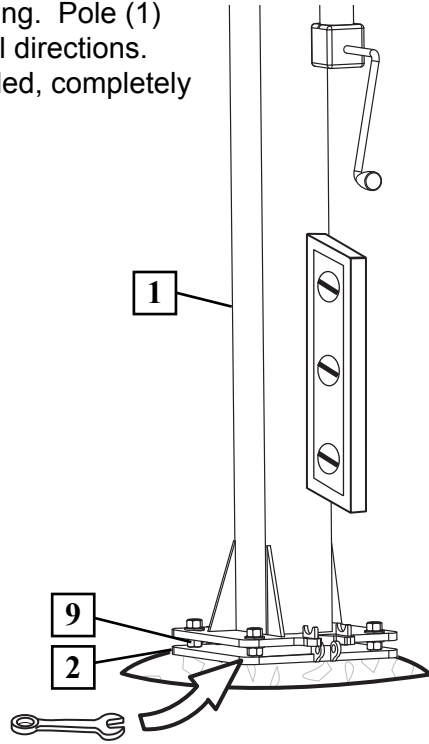

NOTE:

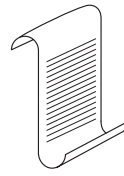

If adjustment is necessary, adjust system by rotating the nuts (9) between anchor plate and pole flange.

19.

Apply height adjustment label (11).

Adjust system by turning crank until desired height is reached per height indicator (30).

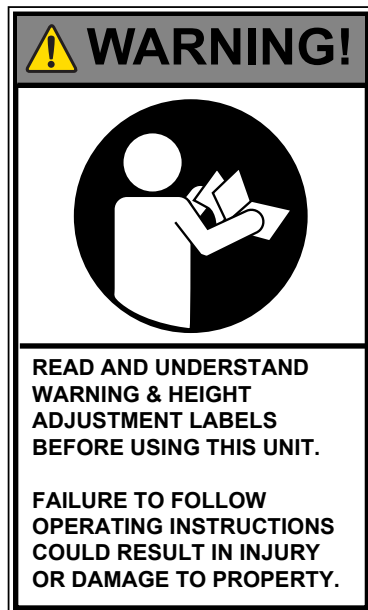

10 feet
(3.05 m)

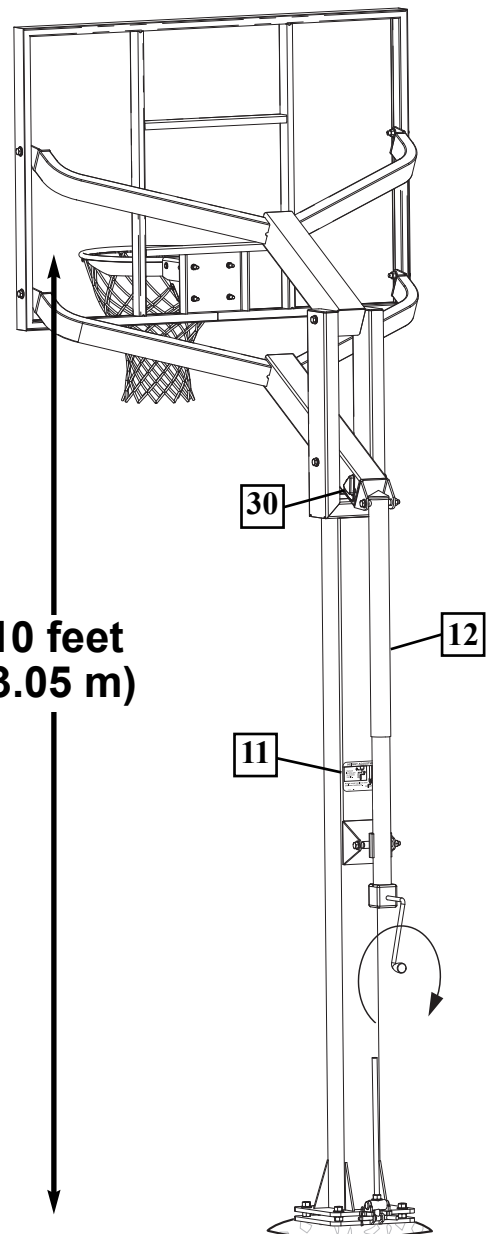

LIMITED LIFETIME WARRANTY

Subject to proper installation and normal use, Spalding® warrants, subject to limitations below, to the original retail purchaser all structural components of the Spalding® system to be free of defects in material and workmanship for the duration of ownership by the original retail purchaser.

Merchandise must be shipped prepaid with a copy of proof of purchase to our factory for examination to see whether it needs to be repaired or replaced. Any labor costs, travel expenses and any other charges involved in the removal, installation or replacement of the defective/repared parts from/to your Spalding® system will be your (the purchaser's) responsibility. Shipping charges for replaced or warranted merchandise being sent back to the customer from our factory must be prepaid by the customer in advance. If not, the replacement shipment will be sent out collect.

What is Not Covered By This Warranty

Paint or rusted parts.

RIM

HANGING ON THE RIM WILL VOID YOUR WARRANTY.

Rims are not warranted for any defects other than workmanship. Torn back plates, damaged springs, bent rings, damaged eye bolts, and torn or distorted rim supports result from hanging on the rim and are not warranted.

Free Manuals Download Website

<http://myh66.com>

<http://usermanuals.us>

<http://www.somanuals.com>

<http://www.4manuals.cc>

<http://www.manual-lib.com>

<http://www.404manual.com>

<http://www.luxmanual.com>

<http://aubethermostatmanual.com>

Golf course search by state

<http://golfingnear.com>

Email search by domain

<http://emailbydomain.com>

Auto manuals search

<http://auto.somanuals.com>

TV manuals search

<http://tv.somanuals.com>