

Owner's Manual

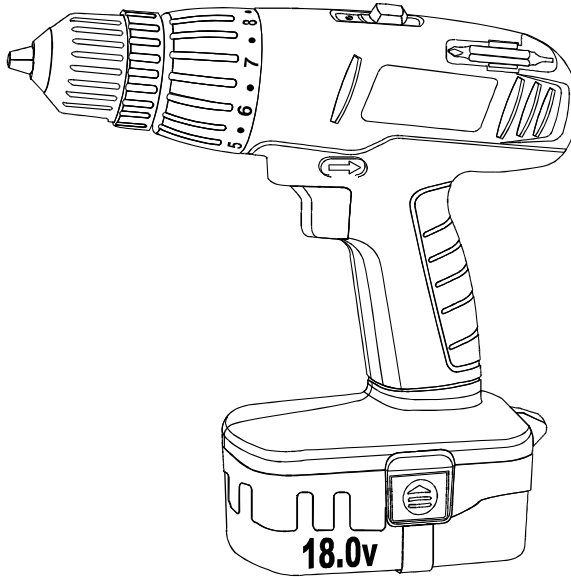

GreatNeck®

18V Cordless Variable Speed 80133



CAUTION:
Before using this cordless drill or any of its accessories, read this manual and follow all its Safety Rules and Operating Instructions.

- General Safety Rules
- Specific Safety Rules and Symbols

- Functional Description
- Assembly
- Operation
- Maintenance
- Accessories

Distributed by GreatNeck Tools LLC, Mineola, NY 11501
Rev 1 03/08

TABLE OF CONTENTS

SECTION	PAGE	SECTION	PAGE
Warranty	2	Know Your Cordless Drill	9
Product Specifications ...	3	Accessories	10
Power Tool Safety	4-6	Carton Contents.....	10-11
Drill Safety	6	Assembly & Operation ..	12-17
Battery & Charger Safety	6-7	Maintenance	18
Symbols	8	Parts & Service	19-21

WARRANTY

One Year Limited Warranty

For one year from the date of purchase of this GreatNeck® product you find any defect in material or workmanship, through normal usage, either return it to the place of purchase, or send it to GreatNeck® Tools LLC. for repair or replacement at our discretion. In order to obtain this service send your tool and proof of purchase, transportation pre-paid, to **GreatNeck® Tools LLC Q.A. Dept, 3580 E. Raines Rd. #3, Memphis, TN 38118**. This warranty gives you specific legal rights, and you may also have other rights, which vary from state to state.

This product is not guaranteed if used for industrial or commercial purposes.

TOLL FREE HELPLINE: 1-866-458-2472

SPECIFICATIONS:

DRILL

Chuck speeds	0–400/0–1150 RPM (no load)
Gearbox	2 speed
Battery	18 V
Clutch positions	17 including drill mode
Keyless chuck	$\frac{3}{8}$ "
Weight	7 lb. 14 oz. (3.6 kg)

BATTERY & CHARGER

Battery Voltage	18 V
Charger	3–5 Hour, Class 2
Charger Input	120 V AC, 60 Hz
Charger Output	25 V DC, 500 mA
Replacement Battery	80133-4

 **WARNING:** To avoid electrical hazards, fire hazards or damage to the battery charger, use proper circuit protection.

The battery charger is wired at the factory for 110–120 V operation. It must be connected to a 110–120 V, 15 A time delayed fuse or circuit breaker. To avoid shock or fire, replace power cord immediately if it is worn, cut or damaged in any way.

POWER TOOL SAFETY

GENERAL SAFETY RULES

⚠ WARNING: Read and understand all instructions. Failure to follow all instructions listed below may result in electric shock, fire and/or serious personal injury.

WORK AREA

Keep your work area clean and well lit. Cluttered benches and dark areas invite accidents.

Do not operate power tools in explosive atmospheres, such as in the presence of flammable liquids, gas or dust. Power tools create sparks which may ignite the dust or fumes.

Keep bystanders, children and visitors away while operating the tool. Distractions can cause you to lose control.

ELECTRICAL SAFETY

Double insulated tools are equipped with a polarized plug (one blade is wider than the other). This plug will fit in a polarized plug only one way. If the plug does not fit fully in the outlet, reverse the plug. If it still does not fit, contact a qualified electrician to install a polarized outlet. Do not change the plug in any way. Double insulation eliminates the need for the three-prong grounded power cord and grounded power supply system.

Avoid body contact with grounded surfaces such as pipes, radiators, ranges and refrigerators. There is increased risk of electric shock if your body is grounded.

Don't expose power tools to rain or wet conditions. Water entering the power tool will increase the risk of electric shock.

Do not abuse the cord. Never use the cord to carry the tools or pull the plug from an outlet. Keep cord away from heat, oil, sharp edges or moving parts. Replace damaged cords immediately. Damaged cords increase the risk of electric shock.

When operating a power tool outside, use an outdoor extension cord marked "W-A" or "W". These cords are rated for outdoor use and reduce the risk of electric shock.

PERSONAL SAFETY

Stay alert, watch what you are doing and use common sense when operating a power tool. Do not use the tool while tired or under the influence of drugs, alcohol or medication. A moment of inattention while operating power tools may result in serious personal injury.

Dress properly. Do not wear loose clothing or jewelry.

Contain long hair. Keep your hair, clothing and gloves away from moving parts. Loose clothing, jewelry or long hair can be caught in moving parts.

Avoid accidental starting. Be sure switch is OFF before plugging in. Carrying tools with your finger on the switch or plugging in tools that have the switch turned ON invites accidents.

Remove adjusting keys or wrenches before turning the tool ON. A wrench or key that is left attached to a rotating part of the tool may result in personal injury.

Do not overreach. Keep proper footing and balance at all times. Proper footing and balance enables better control of the tool in unexpected situations.

SAVE THESE INSTRUCTIONS FOR REFERENCE

SAVE THESE INSTRUCTIONS FOR REFERENCE

POWER TOOL SAFETY

Use safety equipment. Always wear eye protection. Dust mask, non-skid safety shoes, hard hat or hearing protection must be used under applicable conditions.

TOOL USE AND CARE

Use clamps or other practical method to secure and support the workpiece on a stable platform. Holding the work by hand or against your body is unsafe and may lead to loss of control.

Do not force the tool. Use the correct tool for your application. The correct tool will do the job better and safer at the rate for which it is designed.

Do not use the tool if the switch does not turn it ON or OFF. Any tool that cannot be controlled with the switch is dangerous and must be repaired.

Disconnect the plug from the power source before making any adjustments, changing accessories or storing the tool. Such preventive safety measures reduce the risk of starting the tool accidentally.

Store idle tools out of reach of children and other untrained persons. Tools are dangerous in the hands of untrained users.

Maintain tools with care. Keep cutting tools sharp and clean. Properly maintained cutting tools with sharp cutting edges are less likely to bind and are easier to control.

Check for misalignment or binding of moving parts, breakage of parts and any other condition that may affect the tool's operation. If damaged, have the tool serviced before using. Many accidents are caused by poorly maintained tools.

Use only accessories that are recommended by the manufacturer for your model. Accessories that may be suitable for one tool may become hazardous when used on another tool.

SERVICE

Tool service must be performed only by qualified personnel. Service or maintenance performed by unqualified personnel could result in risk of injury.

When servicing a tool, use only identical replacement parts. Follow instructions in the Maintenance section of this manual. Use of unauthorized parts or failure to follow Maintenance instructions may create a risk of electric shock or injury.

SPECIFIC SAFETY RULES

⚠ WARNING: For your safety, do not plug in your charger or install the battery in the tool until you have carefully read and understood this Owner's Manual.

- **Wear eye protection.** Use face or dust mask along with safety goggles if operation is dusty. Use hearing protection, particularly during extended periods of operation.
- **Do not** wear gloves, neckties or loose clothing.
- **Do not** drill, cut, or sand material too small to be securely held.
- **Always** keep hands out of the path of the drill bit and saw blade. Avoid awkward hand positions where a sudden slip could cause your hand to move into the path of the drill bit or saw blade.

POWER TOOL SAFETY

SPECIFIC SAFETY RULES – cont'd

- **Secure workpiece.** Use clamps or a vice to hold the workpiece. It is safer than using your hand and it frees both hands to operate the tool.
- **Make sure** there are no nails or foreign objects in the part of the workpiece to be cut, drilled or sanded.

DRILL SAFETY

- **To avoid injury** from accidental starting, always remove the battery from the tool before installing or removing a drill bit, saw blade, sandpaper, accessory or attachment.
- **Do not** install or use any drill bit that exceeds 7" (175 mm) in length or extends more than 6" (150 mm) beyond the chuck jaws. They can bend or break suddenly.
- **Before starting** the operation, jog the drill switch to make sure the drill bit does not wobble or vibrate.
- **Do not use** fly cutters or multiple-part hole cutters, as they can come apart or become unbalanced in use.
- **Make sure** the spindle has come to a complete stop before touching the chuck or attempting to change the drill bit.
- **Always make sure the chuck is tight and the drill bit firmly tightened in the chuck** before starting drill.

BATTERY & CHARGER SAFETY



- **Do not store or carry battery in a manner in which metal objects could contact the exposed metal end.** Do not place battery in aprons, pockets, drawers, etc. with loose nails, screws, keys etc. The battery could short circuit causing a fire, personal injury or damage to the battery.
- **Never attempt to open the battery for any reason.** If the housing of the battery breaks or cracks, immediately discontinue use and do not recharge.
- **Do not charge the battery if it is wet or shows any evidence of corrosion.**
- A small leakage from the battery may occur under extreme usage, charging or temperature conditions. This does not indicate a failure. **If however, the outer seal is broken and this leakage gets on your skin, follow these steps:**
 1. Wash immediately with soap and water.
 2. Neutralize with a mild acid such as lemon juice or vinegar.
 3. If liquid gets into your eyes, flush immediately with clean water for a minimum of 10 minutes and seek medical attention.**NOTE:** The battery liquid is a 20–35% solution of potassium hydroxide.
- **Do not incinerate the battery.** It can explode in a fire.
- **Do not use an extension cord.** Plug the charger cord directly into an electrical outlet.









BATTERY & CHARGER SAFETY

- **Use the charger only in a standard 110–120 V 60 Hz electrical outlet.**
- **Charge the battery only with the charger supplied with the drill.**
- **Do not use the charger in wet or damp conditions.** It is intended for indoor use only. Do not use the charger near sinks or tubs. Do not immerse the charger in water.
- **Do not allow the cord to hang over the edge of a table or counter or touch hot surfaces.** The charger should be placed away from sinks and hot surfaces.
- **Do not use charger to charge any batteries other than the drill batteries.** Other batteries may explode.
- **Do not operate charger if cord or plug is damaged.** Replace damaged cord and plug immediately.
- **Do not operate charger if it has received a sharp blow,** been dropped or otherwise damaged in any way. Have a qualified technician examine the charger and repair it if necessary. Do not disassemble the charger.
- For best results, only charge the battery when the temperature range of the battery or work area is between 10–40°C (50–105°F).
- **Unplug the charger when not in use** and before cleaning or maintenance.
- **Do not abuse the cord.** To reduce the risk of damage to the electric cord or plug, never carry the charger by the cord or yank the cord to pull the plug. Always grasp the plug and pull to disconnect. Always keep the cord away from heat, oil and sharp edges.

SYMBOLS

⚠ WARNING: Some of the following symbols may be used on your tool. Please study them and learn their meaning. Proper interpretation of these symbols will allow you to operate the tool better and safer.

V	volts
A	amperes
Hz	hertz
W	watt
kW	kilowatts
	microfarads
L	liters
kg	kilograms
H	hours
N/cm²	Newtons per square centimeter
Pa	Pascals
Min	minutes
S	seconds
	alternating current
	three-phase alternating current

	three-phase alternating current with neutral
	direct current
n_o	no load speed
	alternating or direct current
	class II construction
	splash proof construction
	watertight construction
	protective earthing at earthing terminal, Class I tools
.../min	revolutions or reciprocations per minute
\emptyset	diameter
0	off position
	arrow
	warning symbol



This symbol designates that this tool is listed with both Canadian and U.S. requirements by Underwriters Laboratories.

KNOW YOUR CORDLESS DRILL

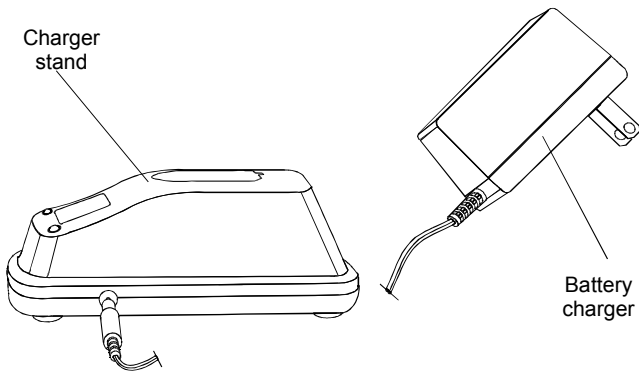
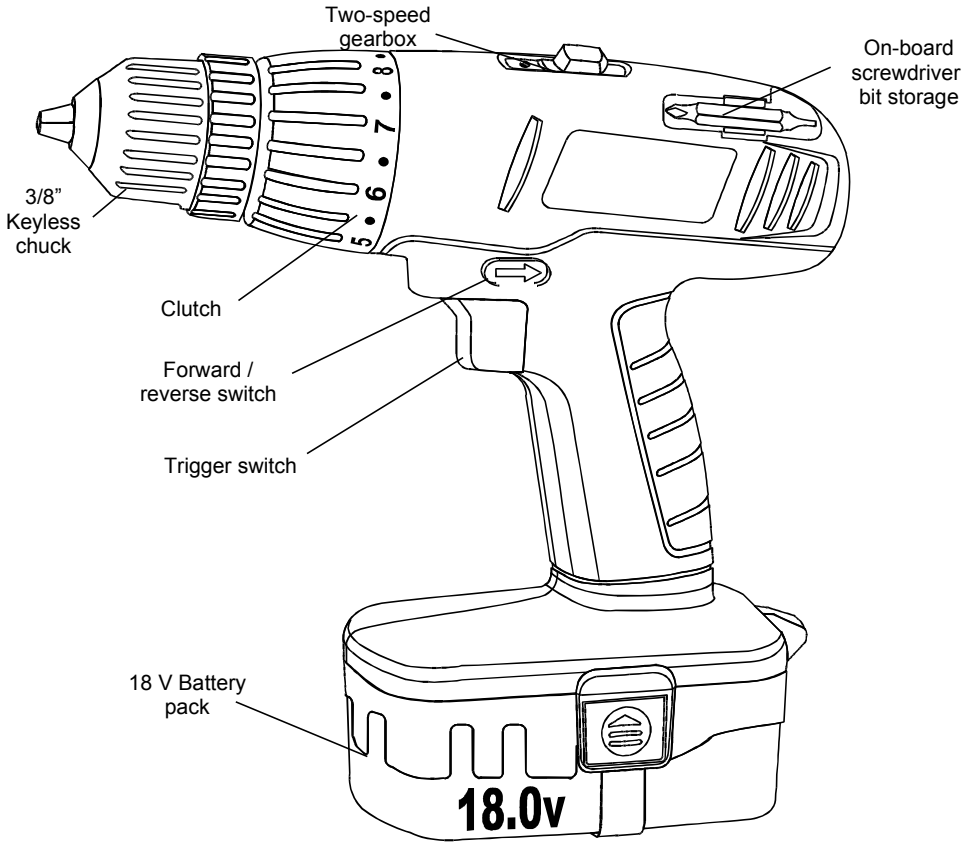

ACCESSORIES & CARTON CONTENTS

AVAILABLE ACCESSORIES

⚠ WARNING: Use only accessories recommended for this cordless drill. Follow instructions that accompany accessories. Use of improper accessories may cause injury to the operator or damage to the cordless drill.

Do not use any accessory unless you have completely read the instructions or Owner's Manual for that accessory.

- Drill bits
- Screwdriver bits

CARTON CONTENTS – cont'd

DRILL

COMPONENTS KEY DESCRIPTION QTY

YADrill 1BD Double-ended screwdriver bits

#1 & #2



#2 & 6 mm

1

1C 18 V Battery pack 1DBattery charger 1EBattery charger stand 1F Blow-molded case 1Owner's manual 1

CARTON CONTENTS

⚠ WARNING: If any part is missing or damaged, do not plug the charger into the power source until the missing or damaged part is replaced.

Carefully unpack the drill. Compare against the "Drill Components" chart at right.

NOTE: See illustration of components on Page 10.

⚠ WARNING: To avoid fire or toxic reaction never use gasoline, naphtha, acetone, lacquer thinner, or any other similar highly volatile solvents to clean the tool.

CARTON CONTENTS

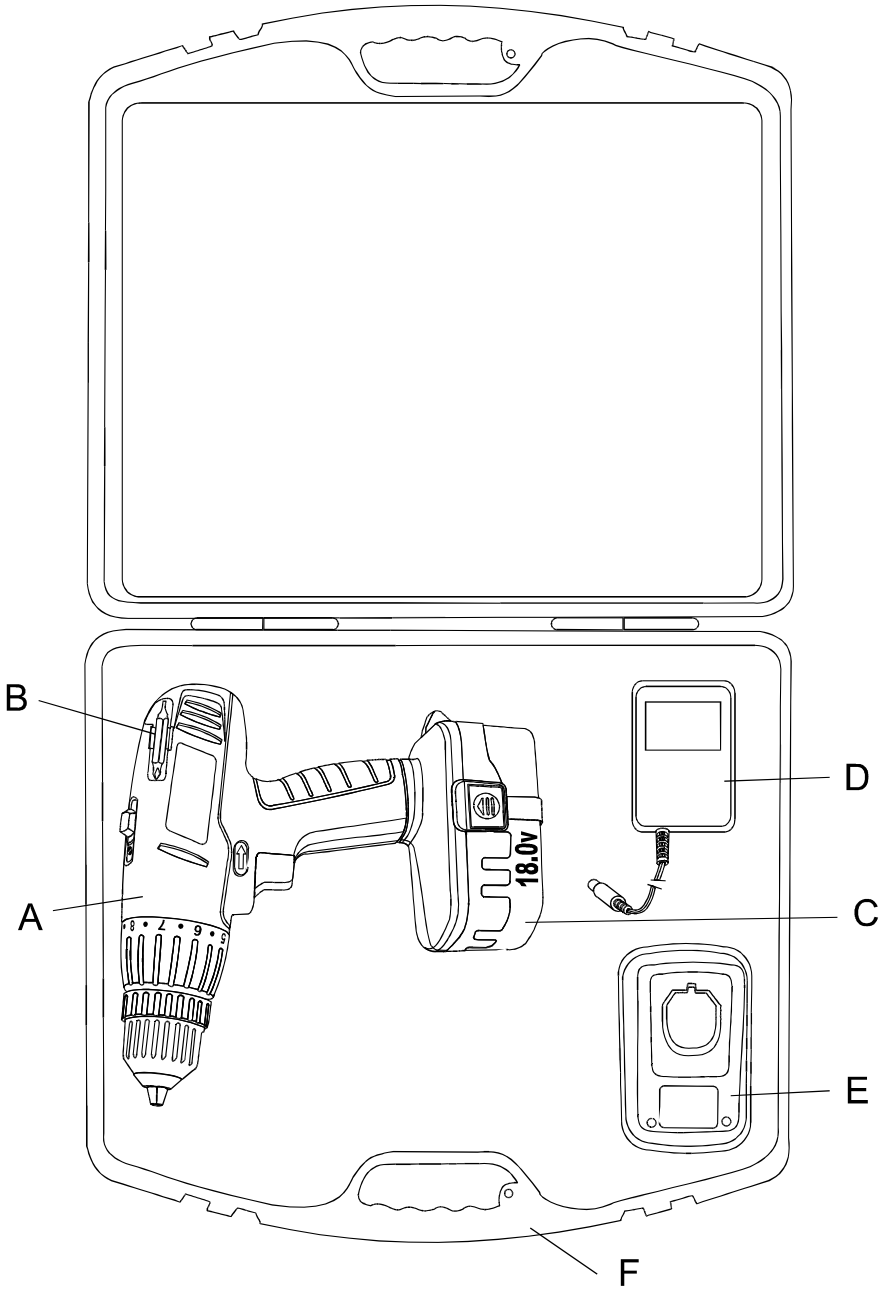

ASSEMBLY & OPERATION

CHARGING THE 18 V BATTERY PACK

1. Place the charging stand near a 110–120 V 60 Hz electrical outlet.
2. Insert small charger plug (1) into charger stand (2) and plug the battery charger (3) into the 110–120 V 60 Hz wall receptacle (Fig. 1).
NOTE: The green indicator light (4) will turn ON.
3. Turn the battery pack (5) upside down and insert it into the matching slots on the charger stand.
NOTES:
 - Make sure the battery pack fits completely into the slots on the charger.
 - The red indicator light (6) will come ON when the battery pack is properly inserted into the charger stand.
 - If red indicator light does not come ON, check to make sure battery pack is inserted fully into the charger and the electrical outlet is working properly.

NOTES:

- A new battery pack or one that is completely run down should be charged for 5 hours. After normal use, a battery pack should be fully charged in about 3 hours.
- It is normal for the battery charger to hum and be warm to the touch during operation.
- If the battery pack does not charge properly, check to make sure the electrical outlet is “live”.
- The battery pack should only be charged in an area where the temperature is between 10–40°C (50–105°F).

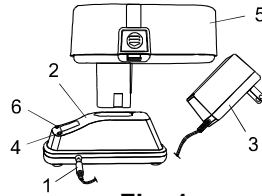

Fig. 1

INSTALLING THE BATTERY PACK IN THE DRILL

1. Remove the discharged battery pack (1) from the tool by pressing the battery release buttons (2) on each side of the battery pack and pulling the battery pack out of the tool handle (3) (Fig. 2).
2. Insert the fully charged battery pack into the matching slots in the tool handle where the discharged battery pack has been removed.
NOTE: The battery release buttons will “click” into place when the battery pack is fully installed.

⚠ WARNING: Do not immerse battery pack in water. Sudden cooling could cause a hot battery to explode or leak.

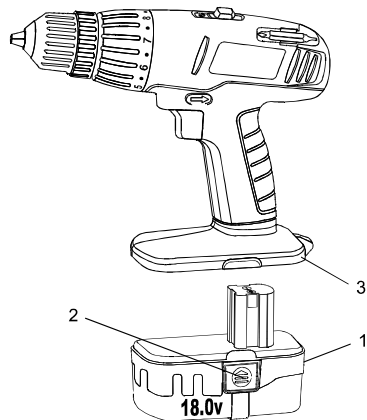

Fig. 2

ASSEMBLY & OPERATION

ON-BOARD SCREWDRIVER BIT STORAGE

Convenient on-board screwdriver bit storage (1) is provided at the rear of the drill housing (Fig. 3).

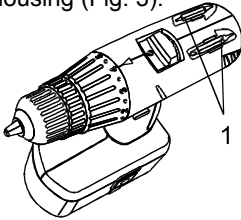

Fig. 3

TORQUE ADJUSTMENT

Your drill is equipped with an adjustable torque clutch for driving different types of screws into different types of materials. The proper setting depends upon the type of material and size of screw being used.

Adjust the torque setting as follows:

1. Identify the torque settings located on the torque adjustment ring (1) (Fig. 4).
2. Rotate adjustment ring to align the correct torque setting number with the torque indicator arrow (2). See chart below for correct torque settings.
 - 1–2 For driving small screws
 - 3–4 For driving medium-sized screws into soft materials
 - 5–6 For driving screws into soft & medium-density materials
 - 7 For driving screws into hardwood
 - 8 For driving large screws
 - Use highest setting for drilling. This position is marked with a picture of a drill bit on the torque adjustment ring.

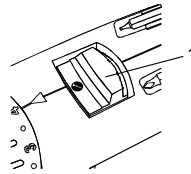

Fig. 4

FORWARD/REVERSE SWITCH

The forward/reverse switch (1) is conveniently mounted above the trigger switch (2) (Fig.5). To make the drill rotate clockwise (for drilling) push the forward / reverse switch to the left. To make the drill rotate counter-clockwise for removing screws, push the forward / reverse switch to the right.

NOTES:

- a) Never change position of the forward/reverse switch while chuck is turning.
- b) The trigger switch will NOT function with the forward/reverse switch in the middle position.

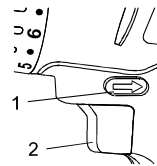



Fig. 5

TWO-SPEED GEARBOX

Set the speed control switch (1) to the desired speed (Fig. 6). Slide the speed control switch toward the rear of the drill for low-speed operation. Slide the speed control switch forward toward the front of the drill for high-speed operation.

NOTES:

- a) Use low-speed setting (position ) for drilling large holes and for driving screws.

ASSEMBLY & OPERATION

TWO-SPEED GEARBOX – cont'd

- b) Use high-speed setting (position ②) for drilling small holes.
- c) Do NOT change the speed control switch position while drill is turned ON. Damage to the gears may result.

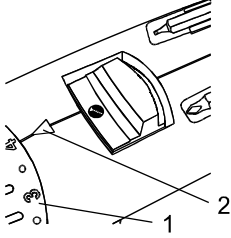

Fig. 6

VARIABLE SPEED TRIGGER SWITCH

This drill is equipped with a variable speed ON/OFF trigger switch.

1. To start drill, gently squeeze the trigger switch (1) (Fig. 7).
NOTE: Drill will turn at its slowest speed when the trigger switch is depressed slightly. The drill will turn at its fastest speed when the trigger switch is fully depressed.
2. To stop the drill, release the trigger switch.

NOTE: Drilling at a slow drilling speed for an extended period of time may cause the drill motor or the battery pack to overheat. If the drill or battery get hot, stop drilling and allow it to cool for at least 15 minutes.

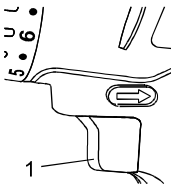

Fig. 7

INSTALLING DRILL BITS

⚠ WARNING: Never hold the chuck body with one hand and use the drill power to rotate the drill body to loosen or tighten bits. Serious injury may result.

1. To open the keyless drill chuck, grasp and hold the chuck collar (1) with one hand (Fig. 8). Rotate the chuck body (2) with the other hand in a counter-clockwise direction (3) until the chuck jaws (4) open wide enough to accept the bit.
2. Insert bit into the chuck the full length of the jaws. Raise the front of your drill slightly to prevent the bit from falling out of the chuck jaws.
3. Tighten the chuck jaws onto the bit by turning the chuck body in a clockwise direction.

NOTE: Make sure the bit is properly aligned in the jaws and NOT at an angle. An improperly aligned bit could be thrown from the chuck when the drill is started. Make sure the chuck jaws grasp the flat sides of a screwdriver bit.

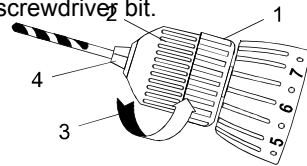

Fig. 8

4. Finish tightening the chuck jaws by holding the chuck collar with one hand and firmly tightening the chuck body by rotating it in a clockwise direction.
NOTE: Hand tighten chuck jaws. Do NOT use pliers.

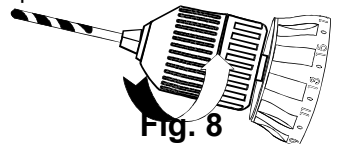

Fig. 8

ASSEMBLY & OPERATION

INSTALLING DRILL BITS – cont'd

⚠ WARNING: Do not insert drill bit into chuck and tighten as shown in Fig. 9. Drill bit **MUST** be properly inserted with all three chuck jaws holding the bit centered in the chuck. Failure to properly insert drill bit could cause the drill bit to be thrown from the chuck resulting in possible serious injury or damage to the chuck.

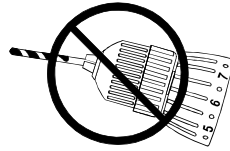

Fig. 9

REMOVING BITS

1. To open the keyless drill chuck, grasp and hold the chuck collar with one hand. Rotate the chuck body with the other hand in a counter-clockwise direction until the chuck jaws open and release the bit.
2. Remove the drill bit.

ASSEMBLY & OPERATION

WARNING

Have you read “POWER TOOL SAFETY”, “DRILL SAFETY”, “BATTERY & CHARGER SAFETY” and “SYMBOLS” on pages 4, 5, 6, 7 & 8 of this Manual? If not, please do so before you operate this drill. Your safety depends on it!

Every time you use the drill you should verify the following:
Chuck is tight.

Workpiece is properly secured.
Safety glasses are being worn.

Failure to adhere to these safety rules can greatly increase the chances of injury.

DRILLING

When drilling into smooth, hard surfaces such as metal, use a centre punch to mark the desired hole location. This will prevent the drill bit from slipping off centre as the hole is started.

The workpiece to be drilled should be secured in a vise or with clamps to keep it from turning as the drill bit rotates (Fig. 10).

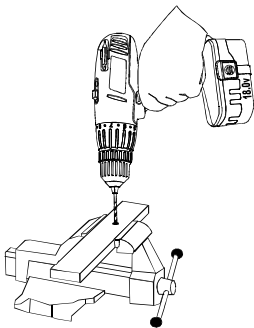

Fig. 10

DRILLING – cont’d

1. Check drill bit to make sure it is firmly locked into the drill chuck and the forward/reverse switch is in the forward position.
2. Set torque clutch to highest setting.
3. Hold the drill firmly with both hands whenever possible. Use one hand to grasp the handle and switch and the other to grasp the body of the drill.
NOTE: Make sure the hand placed on the body of the drill does not cover the air vents. Covering these air vents will reduce the motor cooling and possibly lead to overheating the motor.
4. While holding the drill firmly, place the point of the drill bit at the point to be drilled. Depress the switch trigger to start the drill.

NOTE: Always use a higher drill speed when drilling small holes. Use a slower drill speed when drilling large holes.

5. Move the drill bit into the workpiece applying only enough pressure to keep the bit cutting. Do not force the drill bit or apply sideways pressure to elongate the hole.

WARNING: Be prepared for binding and bit breakthrough. When these situations occur, the drill bit has a tendency to grab the workpiece. This action will kick the drill opposite to the direction of drill bit rotation and could cause loss of control when breaking through material as you complete drilling the hole. If you are not prepared, this loss of control can result in serious injury.

ASSEMBLY & OPERATION

When drilling metals, use a light oil on the drill bit to keep it from overheating. The oil will prolong the life of the drill bit and improve the drill cutting action. If the bit jams in the workpiece or if the drill stalls, release the trigger switch immediately. Remove the bit from the workpiece and determine the reason for jamming.

DRIVING SCREWS

When driving screws, care must be taken to use the bit that correctly fits the screw being driven. Make sure you use the largest bit size that will properly fit into the head of the screw.

1. Select the correct screwdriver bit for the screw being driven.
2. Fasten the screwdriver bit into the chuck, making sure the flats of the bit are gripped by the chuck jaws.
3. Set the torque clutch to the appropriate setting based on the chart shown on Page 13.
4. If the screw is driven too far into the workpiece before the clutch releases, set the clutch to a lower setting and do not pull the trigger switch fully back. If the screw is not driven far enough into the workpiece, set the clutch at a higher setting.

NOTE: Do not continue to drive the screw once the clutch has released. This will damage the clutch.

CHUCK REMOVAL

The drill chuck must be removed in order to use some accessories. To remove the chuck:

CHUCK REMOVAL – cont'd

1. Remove the battery pack from the drill.
2. Insert a 5/16" or larger hex key (1) into the chuck (2) and tighten the chuck jaws securely. Make sure the chuck jaws (3) are seated on flat surface of the hex key (Fig. 11).
3. Tap the hex key sharply with a mallet (4) in a clockwise direction. This action will loosen the screw in the chuck for easy removal.

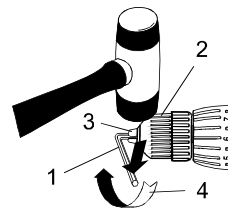

Fig. 11

4. Open chuck jaws and remove hex key.
 5. Open chuck jaws as far as possible.
 6. Remove the chuck screw using a #2 (+) screwdriver (Fig. 12).
- NOTE:** Turn screw CLOCKWISE to remove it. This screw has a left-handed thread.

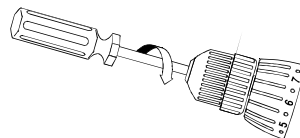

Fig. 12

7. Insert hex key into chuck and tighten jaws of chuck securely (Fig. 13). Tap the hex key sharply with a mallet in a COUNTER-CLOCKWISE direction. This will loosen the chuck on the spindle. The chuck can now be unscrewed and removed from the spindle by hand.

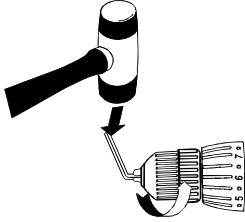

Fig. 13

RETIGHTENING LOOSE CHUCK

After installing the chuck once it has been removed, the chuck may become loose on the spindle and develop a wobble. Also, the chuck screw may become loose causing the chuck jaws to bind and prevent them from closing. To tighten the chuck, follow these steps:

1. Insert hex key into chuck and tighten chuck securely.
2. Tap hex key sharply with a mallet in a CLOCKWISE direction (Fig. 11). This will tighten the chuck on the spindle.
3. Open chuck jaws and remove the hex key.
4. Tighten the chuck screw using a #2 ⊕ screwdriver.
NOTE: Turn screw COUNTER-CLOCKWISE to tighten it. This screw has a left-handed thread.

GENERAL

⚠ WARNING: When servicing, use only identical GreatNeck® replacement parts. Use of any other part may create a hazard or cause product damage.

DO NOT use solvents when cleaning plastic parts. Most plastics are susceptible to damage from various types of commercial solvents and may be damaged by their use. Use clean cloth to remove dirt, dust, oil, grease etc.

⚠ WARNING: Do not at any time allow brake fluids, gasoline, petroleum-based products, penetrating oils, etc. to come in contact with plastic parts. They contain chemicals that can damage, weaken or destroy plastic.

DO NOT abuse power tools. Abusive practices can damage the tool as well as the workpiece.

⚠ WARNING: DO NOT attempt to modify tools or create accessories not recommended. Any such alteration or modification is misuse and could result in a hazardous condition leading to possible serious injury. It will also void the warranty.

LUBRICATION

All of the bearings in this tool are lubricated with a sufficient amount of high-grade lubricant for the life of the unit under normal conditions. Therefore, no further lubrication is required.

PARTS DIAGRAM – MODEL 80133

Cordless Drill

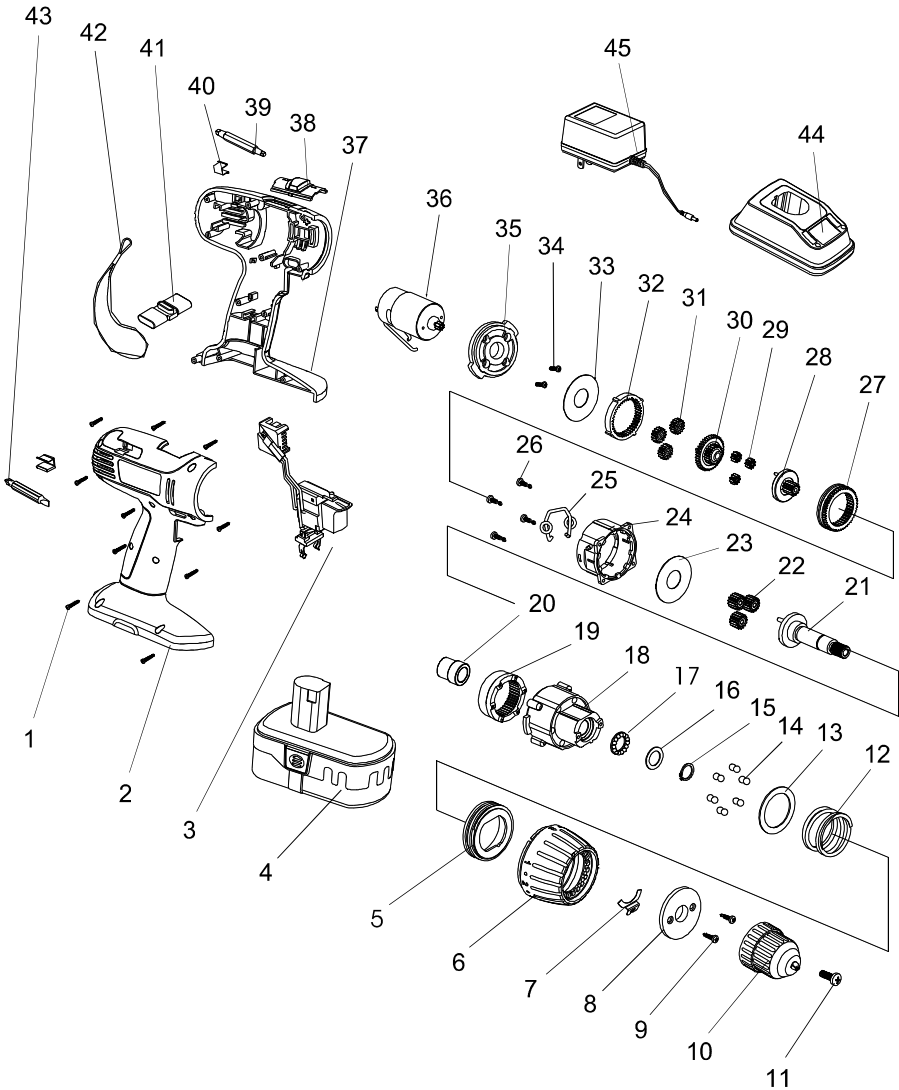

PARTS LIST – MODEL 80133

Cordless Drill

⚠ WARNING: When servicing, use only GreatNeck® replacement parts. Use of any other parts may create a HAZARD or cause damage to your power tool.

Any attempt to repair or replace electrical parts on this power tool may create a hazard unless repair is performed by a qualified technician.

Always order by PART NUMBER, not by key number

Key #	Part #	Part Name	Quantity
1	500001	Self-tapping screw	10
2	306036	Right enclosure	1
3	163608	Switch assembly	1
4	654500	18 V Battery pack	1
5	315821	Inner threaded ring	1
6	312075	Torque setting ring	1
7	242503	Positioning spring	1
8	152502	Clamping plate	1
9	500005	Tapping screw	1
10	161100	Chuck	1
11	500813	Chuck screw	1
12	241515	Spring	1
13	221209	Washer	1
14	516001	Ball group	2
15	511001	Retaining ring	1
16	221210	Washer	1
17	516000	Small ball group	15
18	316808	Gearbox	1
19	201308	Ring gear	2
20	205516	Shaft coat	16
21	213708	Shaft	1
22	200021	Planetary gear	1
23	221226	Clamping plate	1
24	316809	Governor box	1
25	242514	Lever	3
26	500006	Self-tapping screw	1
27	201307	Movable ring gear	3
28	144008	Planetary carrier	1
29	200015	Planetary gear	2

PARTS LIST – MODEL 80133

Key #	Part #	Part Name	Quantity
30	144016	Planetary carrier	1
31	200016	Planetary gear	1
32	201311	Fixed-ring gear	1
33	221228	Clamping plate	1
34	500801	Self-tapping screw	1
35	316504	Motor flange	1
36	130018	Motor	1
37	306036	Left enclosure	1
38	312857	Two-speed selector	1
39	323503	Driver bit	1
40	616000	Bit holder	1
41	311512	Direction setting button	1
42	612000	Strap	1
43	662000	Driver bit	1
44	652102	Charger base	1
45	652101	AC-DC adaptor	1

Free Manuals Download Website

<http://myh66.com>

<http://usermanuals.us>

<http://www.somanuals.com>

<http://www.4manuals.cc>

<http://www.manual-lib.com>

<http://www.404manual.com>

<http://www.luxmanual.com>

<http://aubethermostatmanual.com>

Golf course search by state

<http://golfingnear.com>

Email search by domain

<http://emailbydomain.com>

Auto manuals search

<http://auto.somanuals.com>

TV manuals search

<http://tv.somanuals.com>