

INSTALLATION INSTRUCTION FOR ATTIC LADDER

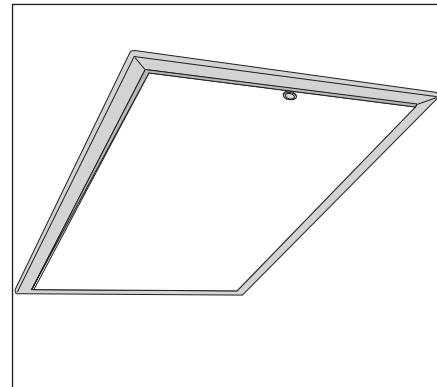

INSTALLERS, CARPENTERS, CONTRACTORS

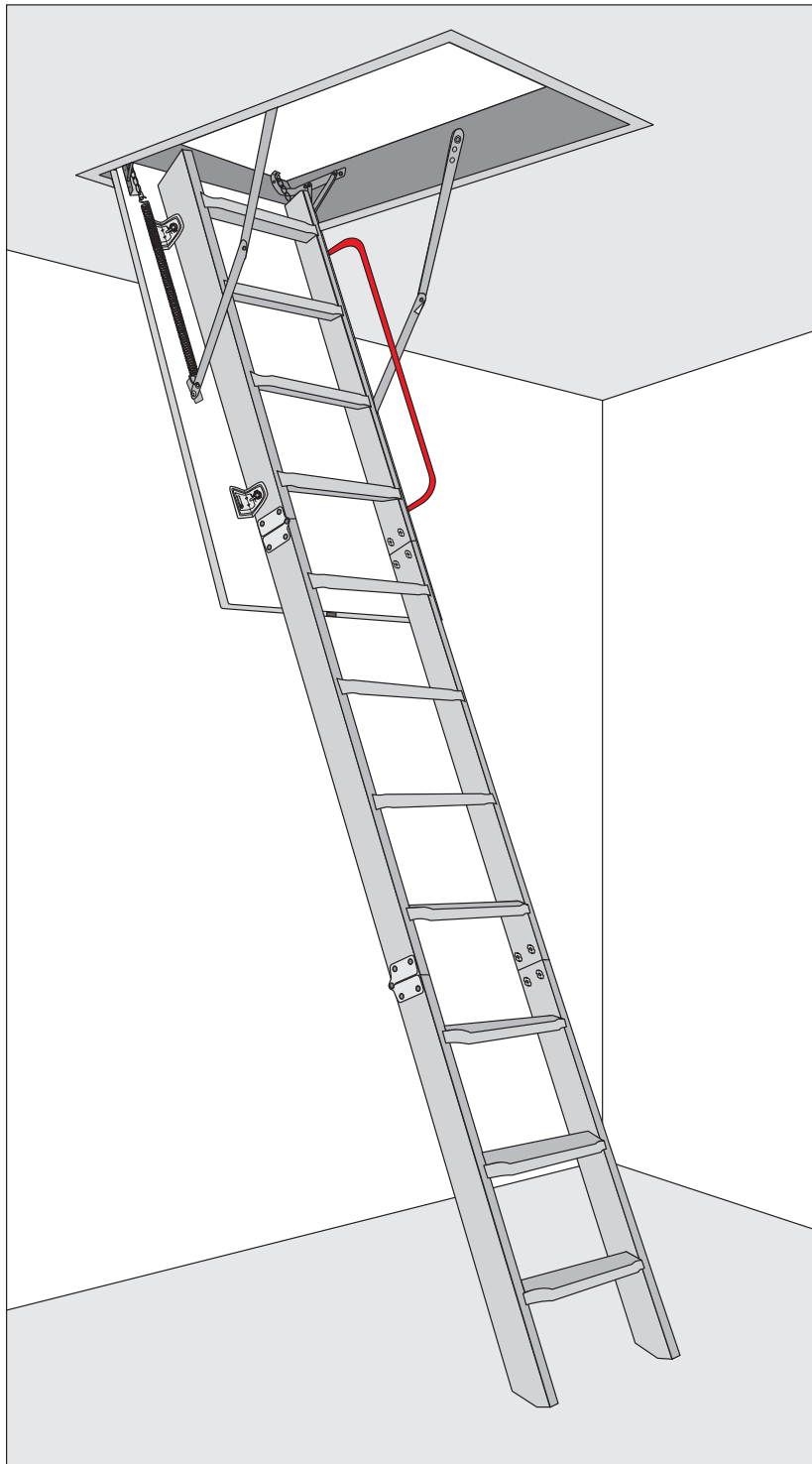

- **Read all warning notes. Warning notes contain important safety tips.**
- **In order to assure safe use of the attic ladder, proceed according to the installation instruction.**
- **The attic ladder is not safe to use, unless it is completely installed according to the following instructions.**

Table of content

I.	Important issues to consider	.pages 2
	- are you able to install attic ladder?	.pages 2
	- will attic ladder satisfy your expectations?	.pages 2
	- does the construction of your ceiling enables installation of the attic ladder?	.pages 2
II.	Your package should contain	.pages 3
III.	Required manpower, tools and materials	.pages 3
IV.	Finding a suitable locations for installation	.pages 4
V.	Cutting a hole in the ceiling	.pages 5
VI.	Cutting the ceiling joists	.pages 6
VII.	Framing the installation opening	.pages 7
	- installing the single headers	.pages 7
	- double headers	.pages 8
	- installation of stringers	.pages 9
VIII.	Installation of the temporary support boards	.pages 9
IX.	Positioning the attic ladder	.pages 10
X.	Shimming, squaring and nailing the attic ladder	.pages 11
XI.	Trimming the attic ladder legs	.pages 12

I. IMPORTANT ISSUES TO CONSIDER

Before you start any work read carefully all instructions, in order to make sure that you have a proper spot for installation and tools.

Are you able to install attic ladder?

In order to install this attic ladder, you need to know how to cut wood and use framing square. Not being able to do the above, installation of this product should be done by a professional installer (refer to yellow pages).

Will attic ladder satisfy your expectations?

The attic ladder has been designed only for home use. Installation of this product in commercial buildings can be obstructing to existing building codes. Before installation of this product consult with Fire Department or your local building inspector.

Maximum load of the attic ladder is 325 LB.

The attic ladder has been designed to be installed in room where the ceiling height is in the range described on the packaging. This product should not be installed if the ceiling height does not fit in the range described on the product's label. Modifications of the attic ladder can be dangerous.

Does the construction of your ceiling enables installation of the attic ladder?

The attic ladder can be installed in buildings with typical wood framed ceiling (Figure1). You should never cut any of the constructing elements of the ceiling without prior consultation with an architect (refer to yellow pages).

The attic ladder should not be installed in chosen spot if there is one of the following:

- ó air ducts
- ó metal constructions
- ó cement ceiling
- ó drop ceiling

If your ceiling has one of the above elements you can not install the attic ladder. In this case you should seek professional help.

The following instruction describes the installation method of the attic ladder.

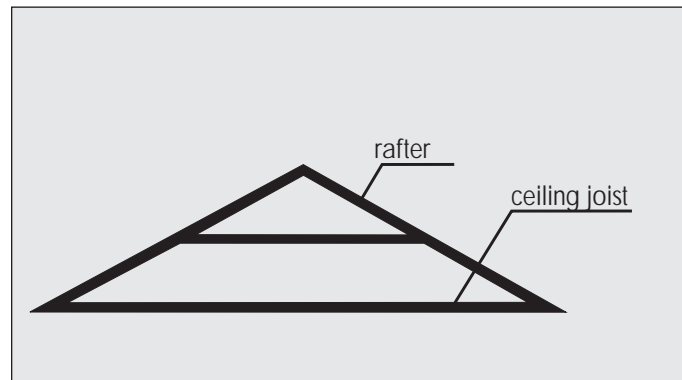

Fig.1. Typical roof construction

WARNING! DO NOT CUT THIS TYPE OF CONSTRUCTION (FIG. 2, 3) WITHOUT PRIOR CONSULTATION WITH AN ARCHITECT.

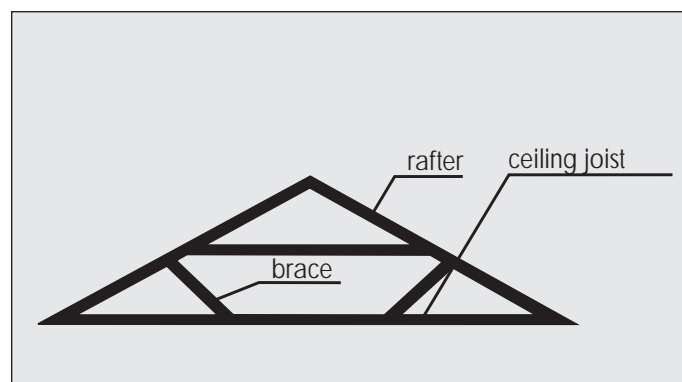

Fig.2. Typical construction of the roof with braces connected to the ceiling joists.

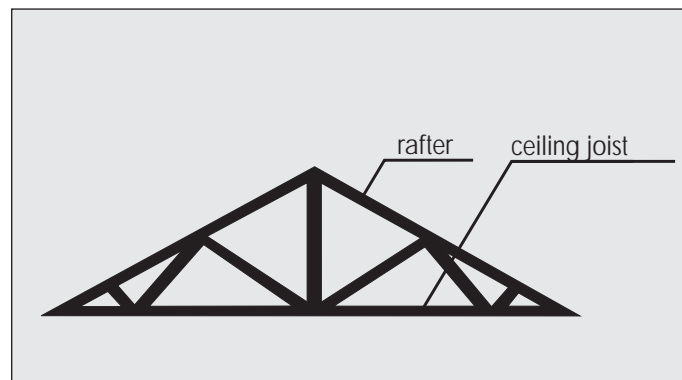

Fig.3. Truss roof frame.

II. YOUR PACKAGE SHOULD CONTAIN:

- ó Attic ladder fully assembled and ready for installation. You should not dismantle assembled product for installation
 - ó Control rod
- Prior to installation inspect the product for any cracks in the wood. Make sure that the metal elements are not damaged and securely fastened.

III. REQUIRED MANPOWER, TOOLS AND MATERIALS

Manpower

- ó 2 people (one must be able to lift 65 LB and carry it in to the attic)

Materials

- ó few pieces of joist-sized lumber
- ó 2 boards 1x4x36E for temporary support
- ó few boards for working platform in the attic space
- ó wood shim stock
- ó 20d sinker nails
- ó 4E screws for wood

Stepladder

Stepladder should be long enough to allow you to enter the overhead space. Make sure that the ladder will withstand your weight +65 Lb.

WARNING

You should be extremely cautious while climbing the ladder, other person should be holding the ladder preventing it from tipping over.

Tools

- ó flashlight
- ó claw hammer
- ó pencil
- ó hand saw
- ó tape measure
- ó framing square
- ó power drill
- ó 1/8E drill bit
- ó tools to cut opening in the ceiling

Safety equipment

- ó gloves
- ó safety goggles
- ó dust mask

IV. FINDING A SUITABLE LOCATION FOR INSTALLATION

Before you begin:

make sure that you have required tools, manpower, and the construction of the ceiling is suitable for installation of the attic ladder.

Look for a space free from obstacles and dangers. Make sure that the space will allow proper installation and use of the attic ladder.

Make sure that the length of the attic ladder is suitable for your ceiling height (fig.4, table 1).

STEP 1

Choose potential installation spot. Check dimension of the required opening, refer to the label or table 2 on page 5.

If the attic ladder will be installed in the garage consider the location of parked cars.

STEP 2

Check the swing clearance. Figure 4 and table 1.

STEP 3

Check the landing space, so that both legs rest on the floor. Figure 4 table 1.

STEP 4

If the attic ladder will fit between the ceiling joists and there is no need for cutting the joists proceed to step 7 d'Framing the installation openingĒ page 7-9.

If it is necessary to cut the ceiling joist proceed to step 6 d'Cutting the ceiling joistsĒ page 6.

STEP 5

Go in to the attic space and locate the spot for installation.

You can find this location by listening for tapping from below or measure the space below and in the attic area.

STEP 6

In the installation spot you should do the following:

- a) check if there is enough room to work during the installation
- b) make sure there are no obstacles (ie. air ducts, electrical installations, etc.) in the attic area disabling safe installation and use of the attic ladder.

Warning

In order to check the attic area for the above mentioned obstacles and dangers put on a dust mask, safety goggles, gloves and proper clothes to prevent cuts caused by mineral wool. Next, slowly lift up the layer of insulation, do not inhale dust and other particles which might be dangerous to your health.

Step 7

If in the chosen spot you find any obstacles, you should find another spot for installation or contact professionals to remove the obstacle (refer to yellow pages).

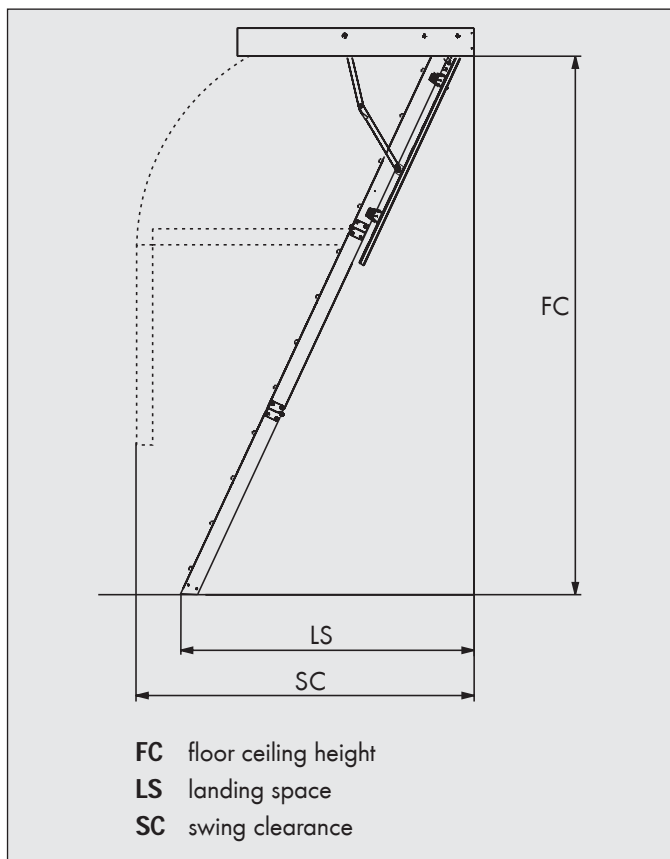

Fig.4. Characteristics of the attic ladder.

MODEL	SC	LS	FC
LWS-P 22/47	67Ē	58Ē	7ĳ4ĳĳ ĳ 8ĳ10ĳĳ
LWS-P 25/47	67Ē	58Ē	7ĳ4ĳĳ ĳ 8ĳ10ĳĳ
LWS-P 22/54	80Ē	64Ē	8ĳ10ĳĳ ĳ 10ĳ
LWS-P 25/54	80Ē	64Ē	8ĳ10ĳĳ ĳ 10ĳ

Table 1

WARNING!

For your own safety do not sit on the ceiling nor the insulation - it was not design to carry load. Only the ceiling joists can withstand your weight. Mind sharp nails sticking out of the ceiling's construction. Do not nail anything in to the ceiling that can conduct electricity until you are sure that there are no electric wires. Contact with electric wires can be deadly.

V. CUTTING A HOLE IN THE CEILING

Before you begin:

find a spot which is:

- ó free from any obstacles in the attic area
- ó free from obstacles in the ceiling
- ó big enough to carry out the installation
- ó big enough to use a step ladder

STEP 1

Prepare the work area. Remove the furniture and cover the floor with a drop cloth. Remove children and pets to a safe distant area.

STEP 2

Put on the safety goggles, dust mask and gloves. These will protect your eyes and lungs.

STEP 3

Using a hammer and a chisel make an initial hole near the center of your chosen location (Figure 5).

STEP 4

Enlarge the initial hole with a hand saw until you can see the joist (Figure 6)

STEP 5

Trace the cutting lines on the ceiling for the installation opening. Make sure that one of the traced lines is parallel to the ceiling joist (Figure7, table 2).

Note:

Having one edge of the opening parallel to the ceiling joist will allow to use it as part of the frame which will be needed for installation.

STEP 6

Cut out and remove remaining part of the ceiling according to traced lines (rectangle) while observing:

- a. not to cut any joists, only the ceiling board
- b. remove the ceiling board by small pieces, because the ceiling materials can be very heavy.

STEP 7

If there are no joists along or across the opening go to section 7 dFraming the installation openingE pg. 7-9.

If there are joists in the cut out opening proceed to section 6 dCutting the ceiling joistsE.

WARNING!

Do not cut, file nor nail anything to the ceiling until you are sure that the chosen space for installation is free from dangers and other obstacles. Contact with electric wires can be deadly.

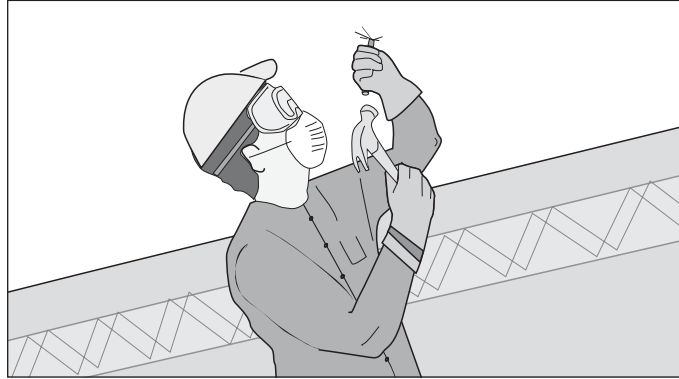

Fig.5. Make an initial hole.



Fig.6. Enlarge the initial hole so that you can see the joist.



Fig.7. Draw a ractangle the size of the ceiling opening.

MODEL	Ceiling opening size
LWS-P 22/47	22-1/2E x 47E
LWS-P 25/47	25E x 47E
LWS-P 22/54	22-1/2E x 54E
LWS-P 25/54	25E x 54E

Table 2

VI. CUTTING THE CEILING JOISTS

Before you begin

You should now have the cut out hole in the appropriate spot.

STEP 1

If the room has a ceiling in which you made the opening proceed to step 2.

If there is no ceiling in place mark the joists according to instruction A or B, below.

A - If the chosen location is parallel to the ceiling joists, mark the length of the opening on the top surface of the joist as shown on Figure 9. Do not cut the joist as marked.

B - If the chosen location is perpendicular to the ceiling joists, mark the width of the opening on the top surface of the joist as shown on Figure 8. Do not cut the joist as marked.

STEP 2.

Cut 2 pieces of board similar to the size of the ceiling joist, long enough to nail them to the ceiling joists on both ends of the opening (Figure 10). These boards will provide support to joists which will be cut out.

STEP 3

Position these boards approximately 2 ft from the opening edge (pic 10).

Note

The 2 ft space is required to nail the frame.

STEP 4

Next decide where you will cut the joist see Figure 11. The cutting line should be away from the actual opening twice the thickness of the frame (usually 3 inches). This will allow to install double headers at both ends of the joist (pic 17 pg.8).

Note

In older homes the thickness of the joist might be greater than what is currently sold in lumber yards. In such case the cutting line should be marked at twice the thicknesses of the material which you will use to build the frame not the joist.

STEP 5

Cut the joist carefully, watching not to cut the ceiling board and making sure that the cut out joist is even and vertical (square).

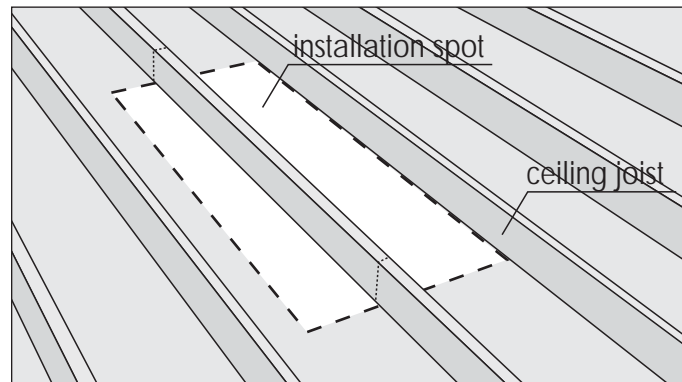

Fig.8. Dotted line indicates your chosen location parallel to the joist.

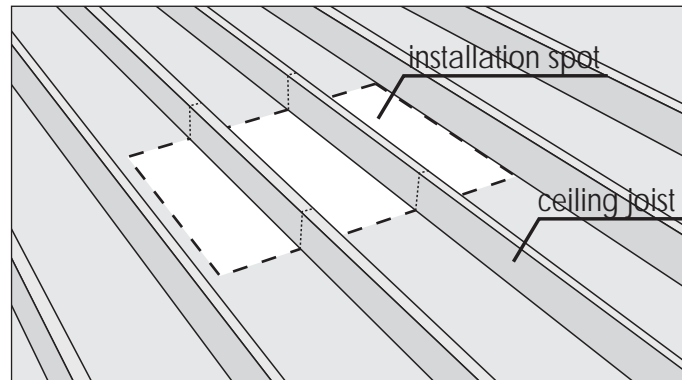

Fig.9. Dotted line indicates your chosen location perpendicular to the joist.

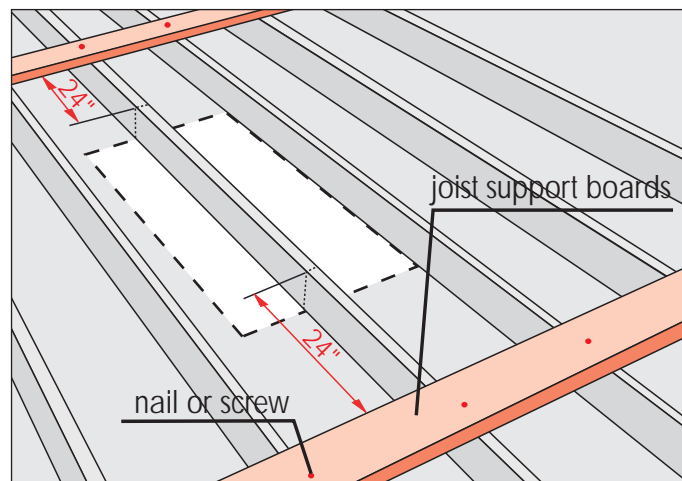

Fig.10. Dotted line indicates your chosen location.

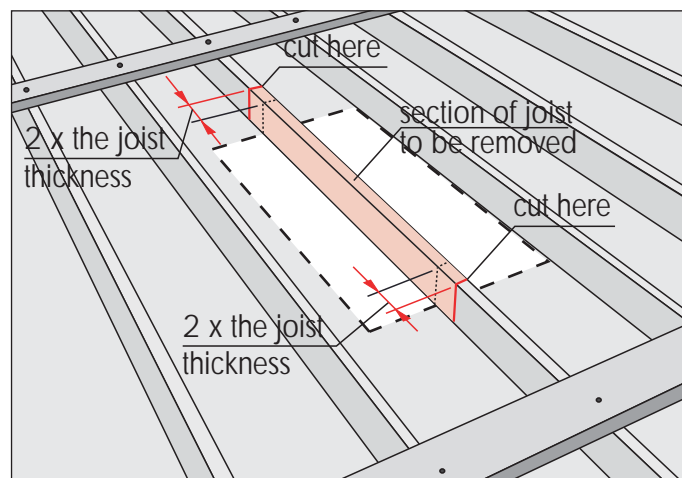

Fig.11. Dotted line indicates your chosen location.

VII. FRAMING THE INSTALLATION OPENING

Before you begin

The distance between the joists should be the same as the width of installation opening. All cut joists must be attached to the joists that have not been cut.

WARNING!

For your own safety mind all dangerous elements above your head. Do not sit on the ceiling - it is not designed to carry load. Only joists will withstand load. In order to make a working area place several boards across the ceiling joists.

Installing the headers

If none of the joists were cut proceed to section d'single headerE.

If one or more joists were cut proceed to section d'double headersE on page 8.

Single headers

STEP 1

Measure the distance between the ceiling joists. The measurement should be done perpendicular to the joist (Figure 12).

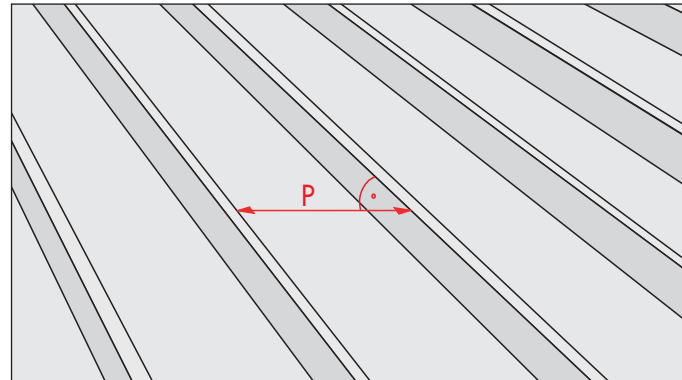

Fig.12. P- Distance between the ceiling joists.

STEP 2

Cut 2 boards for headers to the measured length. Use timber material similar in size to the joists.

STEP 3

Position the header at one end of the installation opening (Figure 13). The header must tightly fit between the joists. If needed use a hammer to position the header.

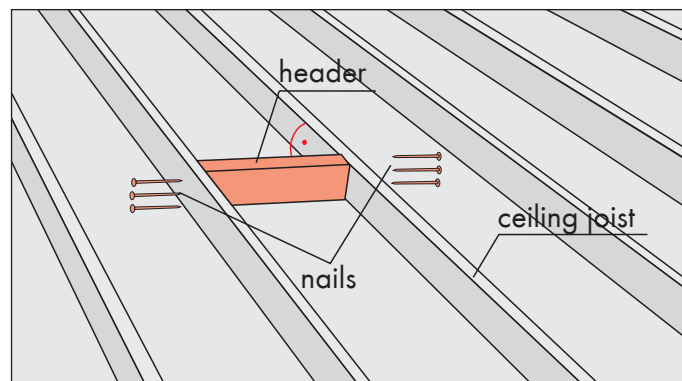

Fig.13. Nail the header at both ends.

Step 4

Align the header at 90° angle to the joists and drive 3 nails (16D) at each end.

STEP 5

Position the second header 47E apart from the first one for LWS-P 22/47, LWS-P 25/47 or 54E for LWS-P 22/54, LWS-P 25/54 and repeat step 4 (Figure 14).

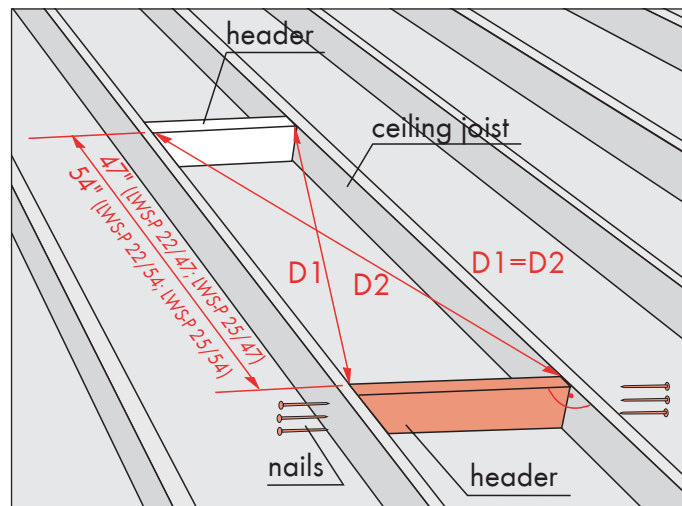

Fig.14.

STEP 6

The frame must have four sides where the headers are two of them. If the ceiling joists are positioned as the other two sides check the angles by measuring the diagonals. Both measured dimensions should be within 1/8E to consider them equal.

Proceed to section 8 d'installation of temporary support boardsE.

If the ceiling joists do not make the other two sides of the frame, you should install one or two wooden elements in order to make the frame in the ceiling opening. Proceed to section d'installation of stringersE.

Double headers

STEP 1

Measure the length of the header d'PĒ between uncut joists (Figure15). The measurement should be done perpendicular to the joists.

STEP 2

Cut to size 4 headers. For that purpose use timber similar in size to existing joists.

STEP 3

Position one header at the end of the cut out joist (Figure16). It must fit tightly between the uncut joists. If needed use a hammer to set the header in the appropriate place.

STEP 4

Square the header to one joist and drive 3 nails (16d) on both ends and to the cut joist (Figure 16).

STEP 5

Position the second header in front of the first one and nail it (Figure 17).

STEP 6

Repeat steps 3-5 in order to install headers at the other side of the ceiling opening.

STEP 7

In order to install other elements of the frame proceed to section d'installation of stringersĒ.

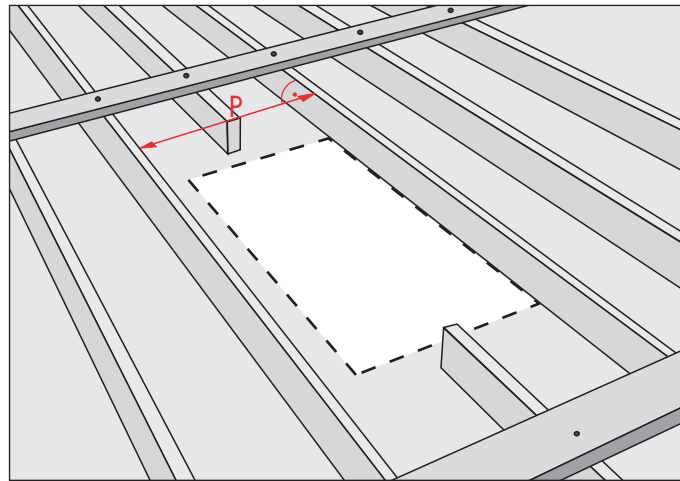

Fig.15. P- Distance between the ceiling joists.

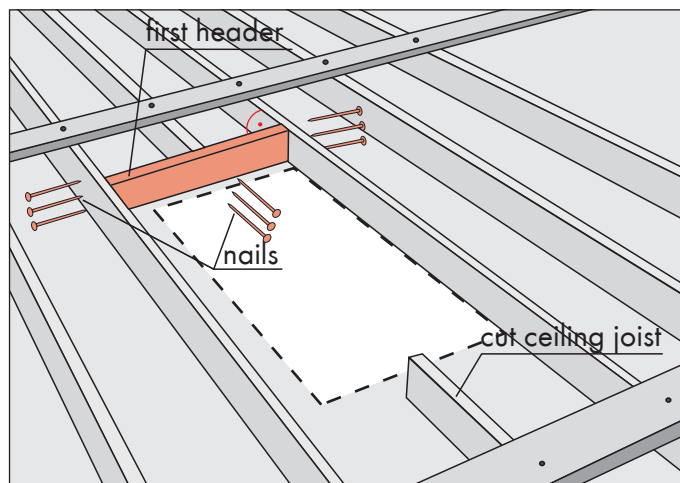

Fig.16.

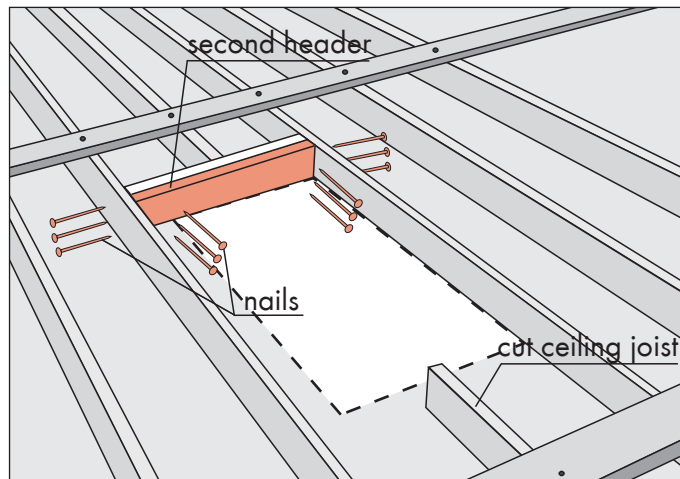

Fig.17.

Installation of stringers

STEP 1

Measure the length of the stringer $d'W\bar{E}$ between the cross-beams (Figure 18). The measurement should be perpendicular to the headers.

STEP 2

Cut the stringer to size. Use timber similar in size to the existing ceiling joists.

STEP 3

If the joists do not make up the other two sides of the frame, you need to install one more stringer of the same length as before. On Figure 18 only one stringer is needed because the ceiling joist makes up one side of the frame.

STEP 4

Position the stringer (or stringers) along the unframed side of the ceiling opening (Figure 19). The inside dimensions of the frame should be equal to the ceiling opening (see product label or table 2 on page 5).

STEP 5

In order to install stringers to the headers you should use nails long enough to go through both cross-beams and enter the stringer at least $1\bar{E}$. In most cases it should be $20d$ nail $4\bar{E}$ long. Square the stringer and drive 3 nails at each end through the double header. Both measured dimensions should be within $1/8\bar{E}$ to consider them equal.

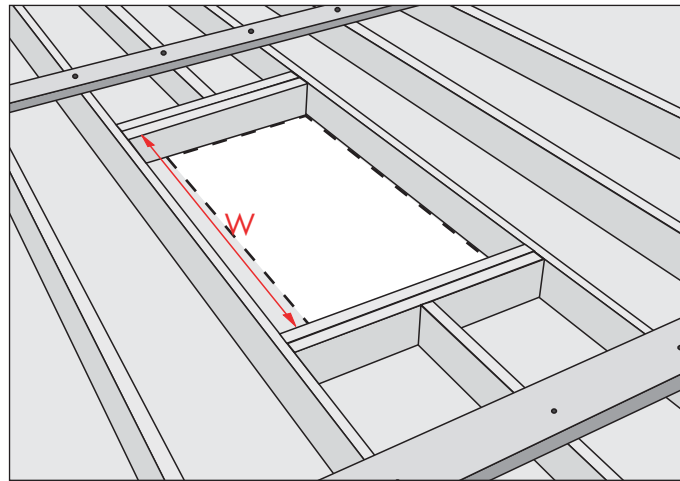

Fig.18. W - Distance between the ceiling joists.

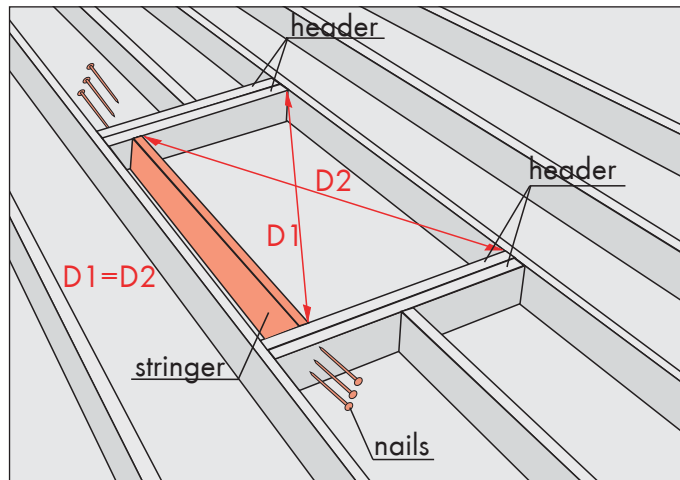

Fig.19.

VIII. INSTALLATION OF THE TEMPORARY SUPPORT BOARDS

Before you begin:

The frame around the ceiling opening must be finished.

STEP 1

Using 4 nails or screws attach the temporary support board $1\bar{E} \times 4\bar{E} \times 36\bar{E}$ where the hinged end of the ladder will be installed. This temporary support board must form a $1/4\bar{E}$ ledge across the ceiling opening (Figure 20).

Note:

It is recommended to use double headed nails which can be easily removed.

STEP 2

Using 4 nails or screws, attach the second temporary support at the other end of the opening so that the temporary support boards are $dX\bar{E}$ inches apart (table 3).

CAUTION: Check the distance between the temporary support boards, it must be equal to the values given in table 3 and fig. 20. The attic ladder can fall down if the temporary support boards are spaced incorrectly.

MODEL	X - distance between headers
LWS-P 22/47	$46-1/16\bar{E}$
LWS-P 25/47	$46-1/16\bar{E}$
LWS-P 22/54	$52-7/8\bar{E}$
LWS-P 25/54	$52-7/8\bar{E}$

Table 3

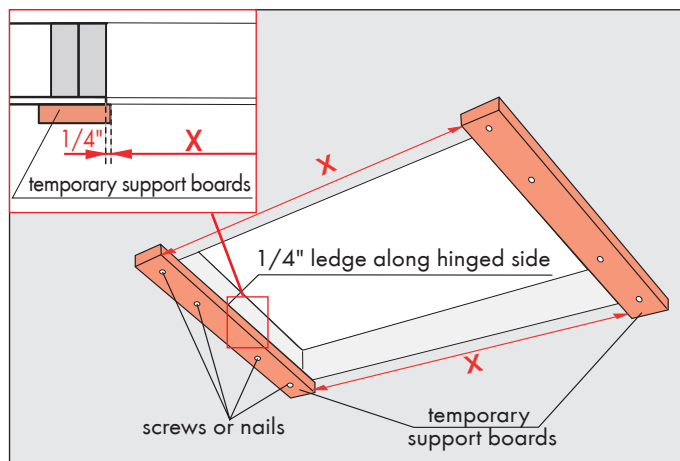

Fig.20. Installation of temporary support boards.

IX. POSITIONING THE ATTIC LADDER

Before you begin:

You must have temporary support boards installed at both ends (Figure20)

STEP 1

Take out the control rod (Figure21). Leave the control rod for the person working below the ceiling.

STEP 2

One person must go in to the attic space while the other person stays below.

WARNING!

The attic ladder can not be used to climb in to the overhead space until it is permanently installed to the previously made frame, and until the legs are trimmed to the appropriate length. Therefore in some cases the person in the overhead space must remain there until the end of installation.

STEP 3

Make sure that people other than installers are kept clear from the working area.

STEP 4

Carefully position the attic ladder on the temporary support so that the hinged end rests on the 1/4" ledge. The person working in the overhead space is blocking the attic ladder with shims, preventing it from falling down from the ledges (Figure22). Shims should be inserted between the case of the attic ladder and the headers at the opening end. Make sure that the attic ladder rests on the temporary support boards.

STEP 5

Open the attic ladder using the control rod by turning it 90° (arrow 1) counterclockwise (Figure23). Pull the lid until fully open and until the blocking mechanism is engaged (arrow 2).

WARNING!

Too abrupt opening of the lid can cause the attic ladder to slip out from the temporary support boards and fall down.

Do not lift up the lid using the control rod until the attic ladder is completely installed. This can cause the attic ladder to slip out from the temporary support boards and fall down.

Do not open the attic ladder by pushing the lid from the above. The tension of the spring rapidly changes, you could loose your balance and fall down.

Do not open the attic ladder by force nor change the positioning of the temporary support boards while the ladder is in place. If the lid is blocked by the temporary support disabling you to open the attic ladder you should remove the attic ladder and re install the temporary support boards.

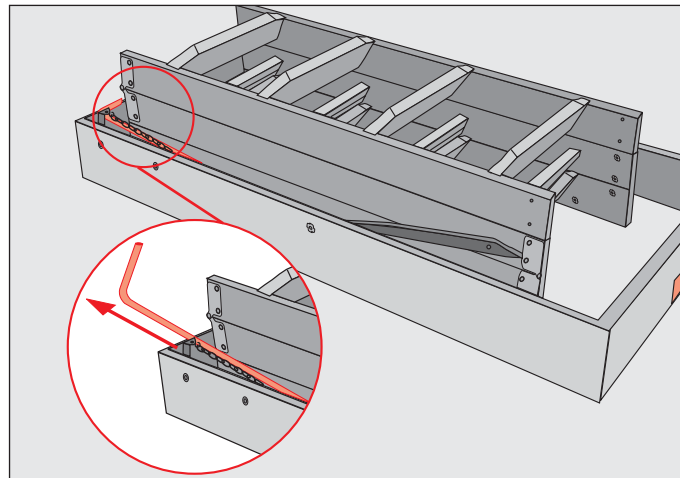

Fig.21.

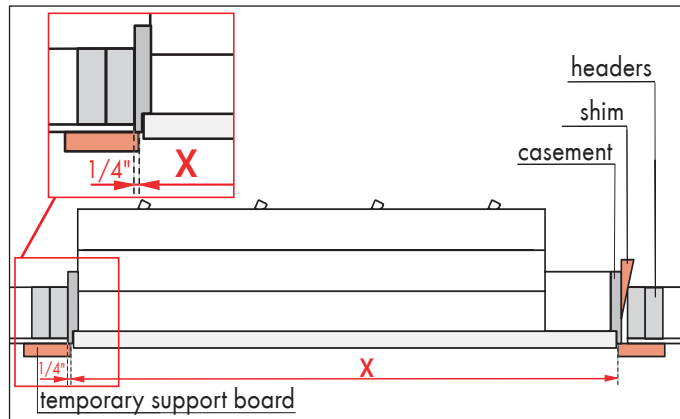

Fig.22.

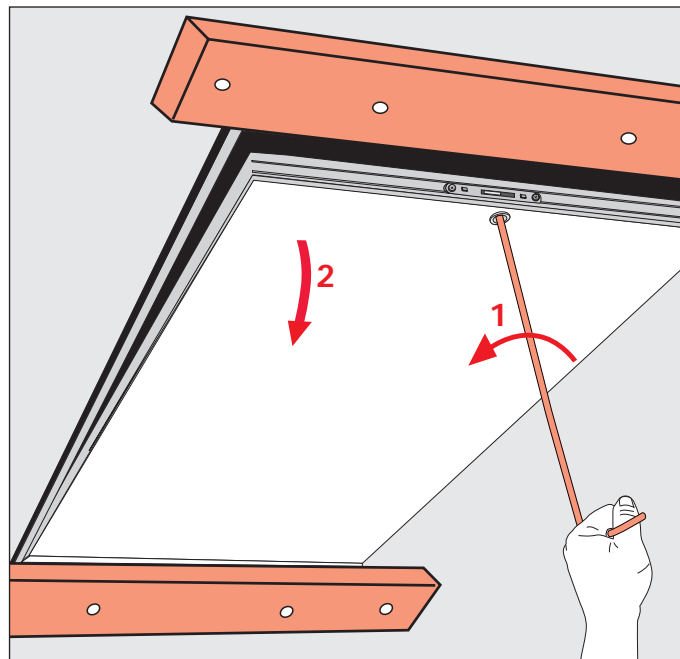

Fig.23.

Warning!

Do not unfold legs of the attic ladder yet. Use of the attic ladder is not safe yet. Do not step on the attic ladder nor leave it unattended until completely installed and both legs are adjusted to rest on the floor. This can damage the attic ladder and cause severe injury.

X. SHIMMING, SQUARING AND NAILING THE ATTIC LADDER.

Before you begin:

The attic ladder should be resting on the temporary support boards. The lid should be openable but do not unfold legs of the attic ladder.

Warning!

Do not unfold legs of the attic ladder yet. Use of the attic ladder is not safe yet. Do not step on the attic ladder nor leave it unattended until completely installed and both legs are adjusted to rest on the floor. This can damage the attic ladder and cause severe injury.

STEP 1

Insert the wooden shims between the case of the attic ladder and the frame (as shown on Figure24) and until it is square in the frame you built. The shims should be inserted from the top and bottom and not extend below the ceiling surface.

Note:

Use of an oversized shims can damage the casement of the attic ladder.

Check the squareness of the frame by measuring the diagonals (Figure24). Both measurements should be within $1/8\text{E}$ to be considered square.

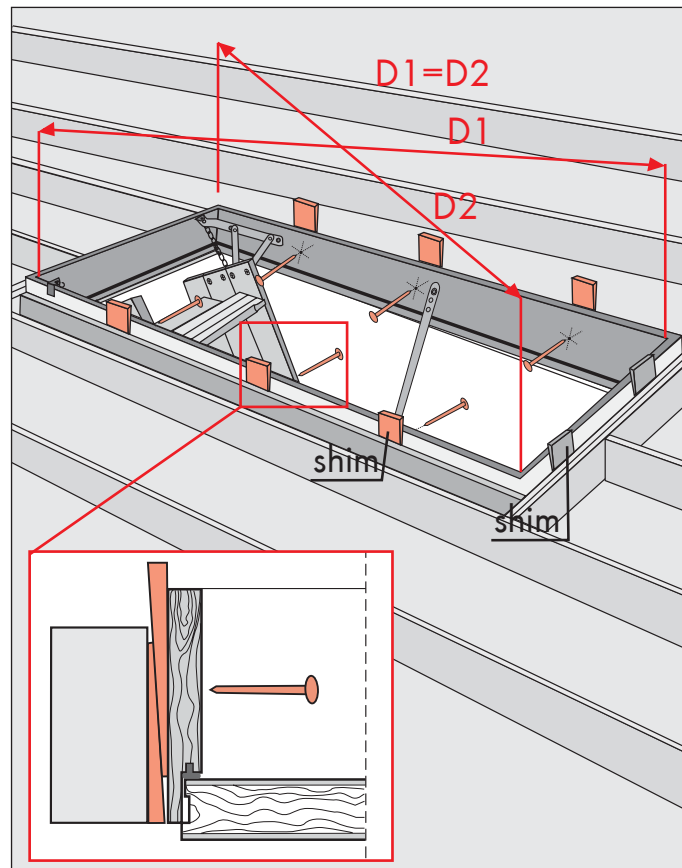

Fig.24.

STEP 2

Using a $1/8\text{E}$ drill bit, pre drill nail locations in the ladder casing (Figure25). Do not drill through joists and headers. Drilling should be done on the longer sides of the casement where the shims are, in the middle of the casement's height.

Nail the attic ladder following instructions:

- Drive 6 nails 20d or screws 4E, check squareness
- Be careful not to hit the spring or the hinge

STEP 3

Trim the sticking out shims. Upon complete installation you can also remove the temporary shims.

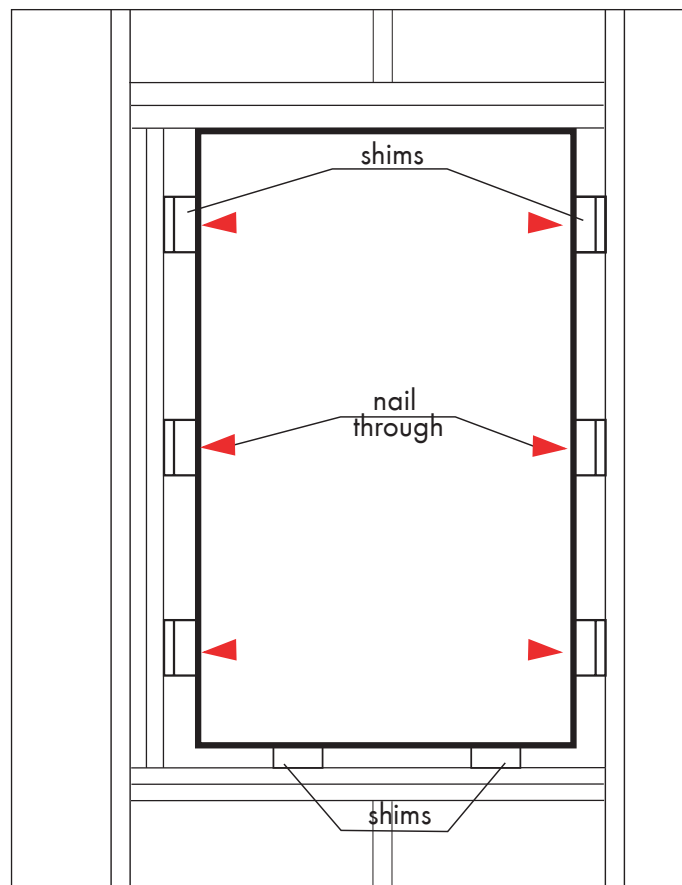

Fig.25. View from the top.

XI. TRIMMING THE ATTIC LADDER LEGS

Before you begin:

The attic ladder should be properly shimmed and securely nailed to the frame in the proper location.

WARNING!

Use of the attic ladder is not safe yet.

Do not unfold the attic ladder yet. Do not step on the attic ladder nor leave it unattended until completely installed and both legs are adjusted to rest on the floor. This can damage the attic ladder and cause severe injury.

STEP 1

Make sure that the lid is fully open. Unfold legs of the attic ladder and fold the bottom section as shown on Figure 26.

STEP 2

Loosen screws as shown by the arrow 1 and move the steps away from the lid as shown by arrow 2 (Figure 27).

STEP 3

Tighten the previously loosened screws as shown by arrow 3 (Figure 28).

WARNING!

Upon completion of these tasks the distance between the steps and the lid should remain constant. Otherwise this can cause damage to the attic ladder and cause severe injuries.

STEP 4.

Using a straight edge measure the distance $d'AE$ and $d'BE$ as shown on Figure 26.

This measurement should be very precise in order to ensure proper trimming of the legs.

ATTENTION

Measure the distance $d'AE$ and $d'BE$ on both sides of the attic ladder. The distance may not be the same on both sides of the attic ladder.

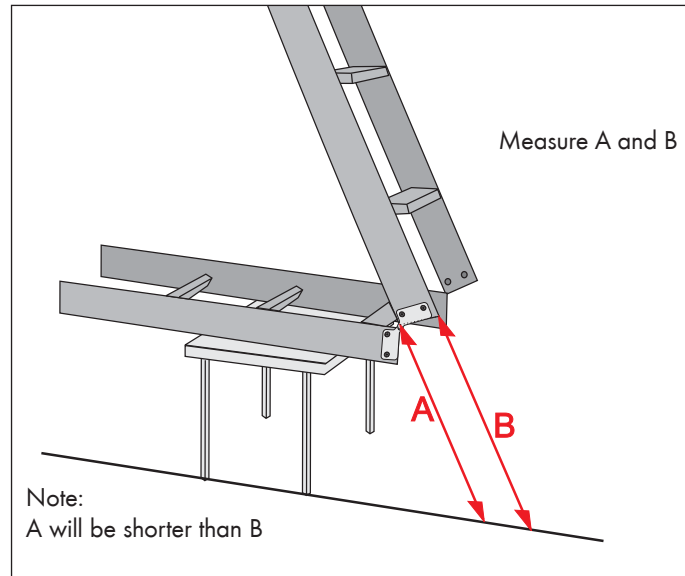

Fig.26.

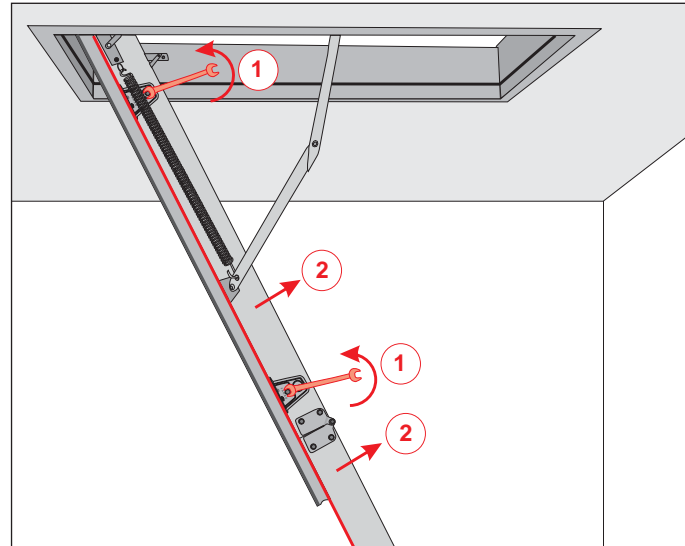

Fig.27.

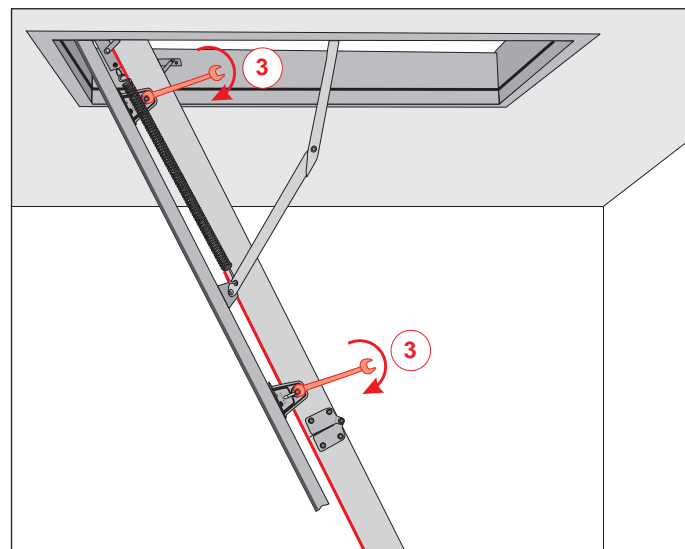

Fig.28.

	Left leg	Right leg
A		
B		

STEP 5

Measure the $d'AE$ and $d'BE$ distance from the top edge of the bottom section of the attic ladder and mark it on both legs (Figure29). Trim lines must be accurate in order to avoid trimming the legs too short.

WARNING!

If the trimming line is marked along the rung, you should reposition the full run of steps where it is attached to the lid. The trimming line must not be in line with the rung (Figure30). Next repeat measurements $d'AE$ and $d'BE$ starting from step 4.

STEP 6

Trim the legs along the trimming lines. Trim the corners of the legs perpendicular to side $d'BE$ but no more than $1/2E$ from the corner (Figure29). Using attic ladder with too short legs will damage the ladder and can cause severe injuries.

STEP 7

Check for proper trimming of the legs, by unfolding the full run. The ladder should look like on Figure 31. There should be no gaps between the metal hinges and the feet should be flush with the floor.

ATTENTION:

Gaps between the metal hinges mean that the feet are not properly trimmed (Figure32 and 33). Do not climb the attic ladder if there are visible gaps between the metal hinges. This can cause damage to the attic ladder and and result in serious injury.

If the attic ladder looks like on Figure 32, one or both legs are too long. Send or trim the feet until there are no gaps between the metal hinges and both legs are flush with the floor.

If the legs look like on Figure 33, both legs are too short. If there are no gaps between the metal hinges but one leg is too short, use of the attic ladder is not safe. If the legs are trimmed too short do not use the attic ladder.

Contact your local dealer.

STEP 8

Remove the temporary support boards.

Congratulations! Your installation is complete!

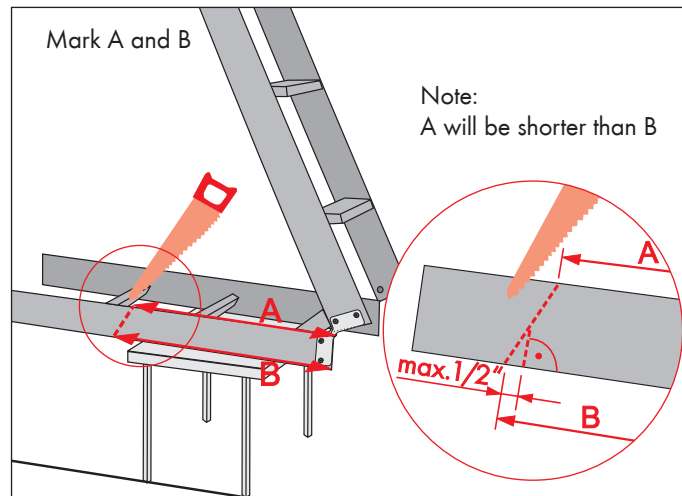

Fig.29.

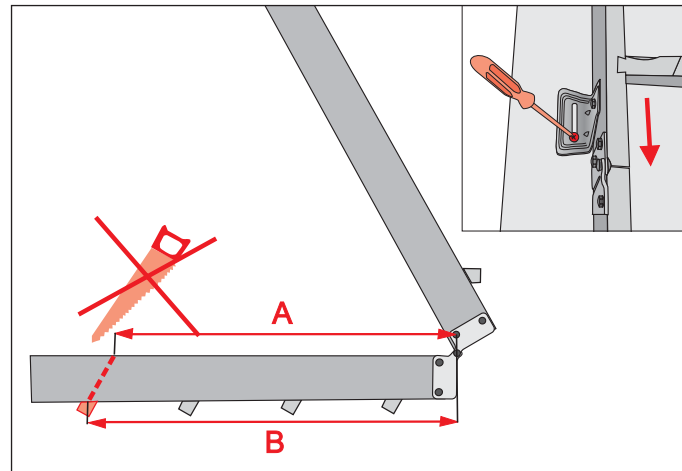

Fig.30.

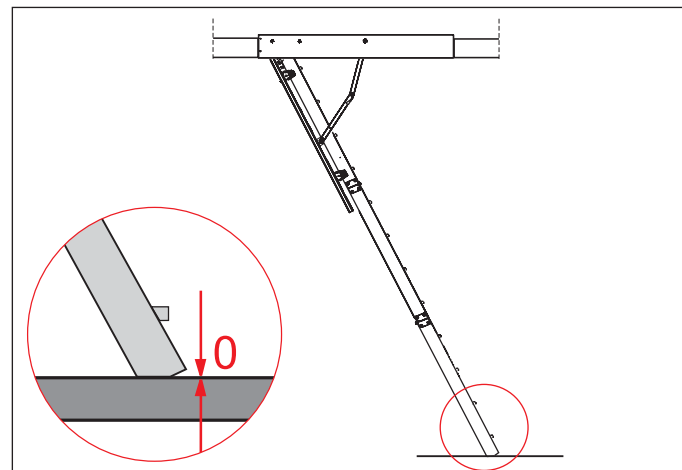

Fig.31. Properly installed attic ladder

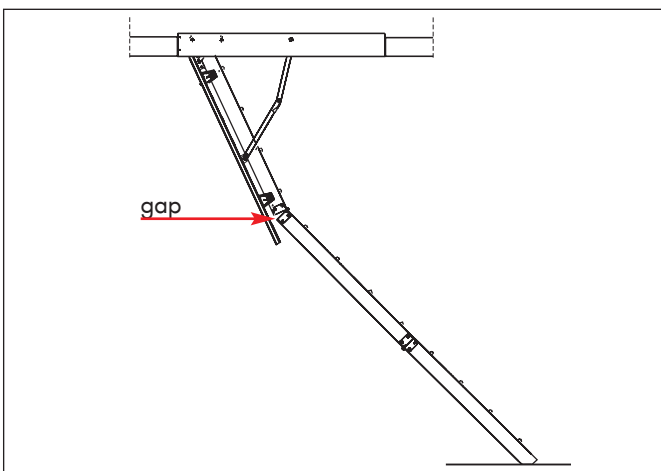

Fig.32. Legs too long.

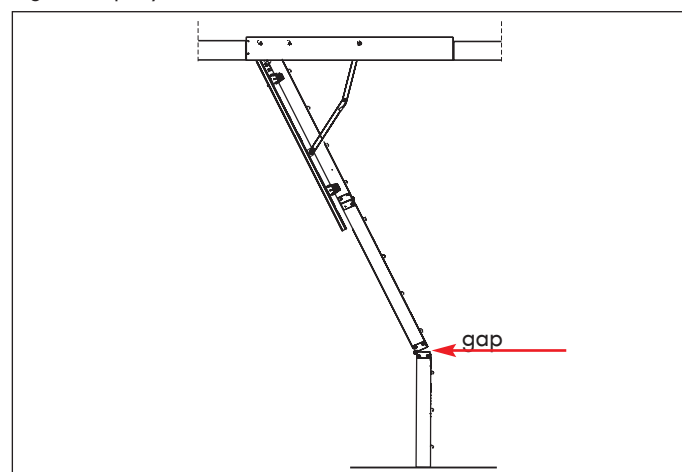

Fig.33. Legs too short.

FAKRO AMERICA, L.L.C.
311 W. Laura Dr
Addison, IL 60101, USA
tel. (630) 543-1010
fax. (630) 543-1011
e-mail: sales@fakro.info
www.fakro.info
www.fakro.com

"FAKRO" and the FAKRO logo are registered trademarks of FAKRO Group.
All specifications are subject to change without prior notice.
©2003 FAKRO GROUP

Free Manuals Download Website

<http://myh66.com>

<http://usermanuals.us>

<http://www.somanuals.com>

<http://www.4manuals.cc>

<http://www.manual-lib.com>

<http://www.404manual.com>

<http://www.luxmanual.com>

<http://aubethermostatmanual.com>

Golf course search by state

<http://golfingnear.com>

Email search by domain

<http://emailbydomain.com>

Auto manuals search

<http://auto.somanuals.com>

TV manuals search

<http://tv.somanuals.com>