



Operating Manual

For



MigWeld 140

140AMP Transformer MIG Welder 110v

Table of Contents:

PG. 3: Thank you From LONGEVITY

PG. 4-6: Warranty/Shipping Damage/Order Information

PG. 7-9: Warning and Safety Information

PG. 10: General Description

PG. 11: Specifications and Ratings

PG. 12-16: Safety Precautions

PG. 17: Unpacking

PG. 18: Components and Controls

PG. 19-23: Installation

PG. 23-24: Welding Operations

PG. 25: Suggested Settings

PG. 26: Overload Protection

PG. 27: Enjoy your new welding machine from LONGEVITY!

THANK YOU!

We, at LONGEVITY, want to thank you for purchasing our product. You are almost ready to experience Longevity Welding first hand. Longevity definitely appreciates your business and understand that this equipment may be overwhelming to setup and operate so we have prepared a manual that will assist you in understand your new plasma cutter/welder. If you have any questions during or after reading this manual, please feel to contact us! Please take a moment to register your product on our website at www.longevity-inc.com or www.lweld.com

Once again, thank you for choosing Longevity as your main welding supplier!

Longevity Global, Inc.
23591 Foley St
Hayward, CA 94545

Toll-Free Customer Support: 1-877-LONG-INC / 1-877-566-4462

Website: www.longevity-inc.com

Sales: sales@longevity-inc.com

Customer Service: help@longevity-inc.com

Dealers: dealers@longevity-inc.com

Complaints: complaints@longevity-inc.com

Please join our welding forums to share welding tips and tricks, to receive useful information from customers who also use our products, and to be a part of the Longevity™ welding community at www.freeweldingforum.com



Check out LONGEVITY Racing at www.longevity-racing.com

Warranty

LONGEVITY Plasma Cutters, Welders, and Multi-Purpose Welders are covered for specific Parts and Labor warranty at our facility. For detailed information regarding your specific LONGEVITY welder or cutter, please view our Terms and Policies page on our website at the following website link: <http://www.longevity-inc.com/terms/>

Shipping Damage

Your machine is insured against damage during shipping. Keep all packing materials and containers in case machine must be returned. We will initiate a claim with the shipping company to cover damage or loss. If there is shipping damage upon opening your package, our customer service team will work with you to get the matter resolved.

In Warranty Service

Customers, who own machines that are in warranty and require service, should contact our Warranty Department by email at help@longevity-inc.com to obtain a return authorization code. In addition to the warranty we offer, we would like for you to register your product on our website at www.longevity-inc.com/resources. Remember, warranty starts from the date of purchase. For your convenience, write your order information below so you can track your order in case you need warranty work.

Order No.: _____

Date of Purchase: _____

Warranty Period: _____

Out-of-Warranty Service

Customers, who own machines that are out of warranty and require service, should contact us for an estimate. Longevity offers an exchange program on out of warranty units. We also help non LONGEVITY customers with repairs, replacement, and service.

If your unit is not manufactured by Longevity and you cannot receive service from your manufacturer or seller, Longevity will lend out hand. Our warranty policy is also available for all plasma cutters and welders. For more information, please email us at help@longevity-inc.com

Warnings and Safety

Welding and plasma cutting may be dangerous to the operator and to bystanders, if the equipment is not operated properly. Welding or cutting must be performed in accordance with all relevant safety regulations. Carefully read and understand this instruction manual before installing and operating this equipment.

Changing function modes during welding may damage equipment.

Before welding, disconnect the electrode-holder cable from the equipment.

A circuit breaker is required to prevent electrical overload of the equipment.

Only high quality welding tools should be used.

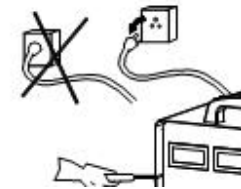

Electric Shock can be fatal.

Ensure that ground cable is connected in accordance with applicable safety codes.

Never touch electrodes, wires, or circuit components with bare hands. Wear dry welding gloves when welding.

The operator must be insulated from the work piece.





Smoke and gas can be harmful to health.

Ensure that the working area is well ventilated.

Avoid breathing smoke and gas generated during the welding process. Cutting and welding can cause cancer because of the smoke that comes from the welds and cuts.

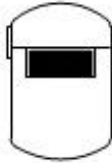
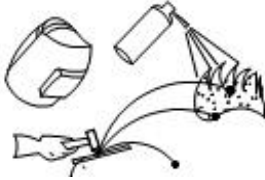

<p>Arc-light emission can be harmful to eyes and skin.</p> <p>Always wear a welding helmet, anti-radiation glass, and work clothes while welding.</p> <p>Ensure that people in or near the working area are protected.</p>	
<p>Welding splash is a fire hazard.</p> <p>Keep flammable material away from the work place.</p> <p>Keep a fire extinguisher nearby, and have all personnel trained in its use.</p> <p>Surface noise generated while welding or cutting can be harmful to hearing.</p>	
<p>In the event of a machine fault.</p> <p>Refer to this instruction manual.</p> <p>If the fault cannot be determined, contact your local dealer or supplier for assistance.</p>	

Safety Tips

Consider the following tips to ensure safe operation of your welding/cutting equipment:

- Ensure that this welding equipment is installed in an area free of corrosive chemical gases, flammable gases or materials, and explosive chemicals.
- The area should contain little dust, and have a humidity of no more than 80%.
- Operate the welding equipment in an area sheltered from direct sunlight and precipitation. Work area temperature should be maintained at -10°C to +40°C;
- If, because of an overload, the machine suddenly stops, and it is necessary to restart it, leave the internal fan operating to lower the inside temperature.
- Always wear protective clothing and a welding mask to protect your skin.
- Wear safety goggles designed to darken the arc generated by your machine.
- Wear suitable noise protection to protect your hearing.
- Ensure that machine is grounded through the power cord or on the machine case.
- Never operate the machine in bare feet or on a wet floor.
- Never switch the machine off while it's in use. Doing so will damage the internal circuitry.
- Ensure that your circuit breaker is rated to handle the current requirements of your machine.
- Use a UL approved receptacles and plugs with your machine. Never hard wire the machine to main power.
- Work in a well-ventilated area to avoid smoke. Keep your head out of the smoke. Ensure that air is flowing away from you to avoid inhaling smoke.
- Ensure proper ventilation through the machine's louvers. Maintain a distance of at least 12 inches between this cutting equipment and any other objects in the work area.
- Use a screen or curtain designed to keep passer byes from viewing the arc.
- The arc spray and metal spray from machine use may cause nearby fires. Use caution.
- If, after reviewing this manual, you have any problems in setting up or operating your machine, contact us at help@longevity-inc.com.

General Description:

The LONGEVITY MIGWELD 140 welder delivers industrial quality and performance at an affordable price. Perfect for the beginner and the professional. The MIGWELD 140 is the most versatile welder which will do aluminum with the optional spool gun in addition to all exotic metals. The MIGWELD 140 will easily connect to your existing 110v wall outlet and can be setup easily in minutes. Running on a standard 110v power cord, which is included, you will be able to lay down a nice weld anywhere.

Operation Manual

Carefully read the operation manual prior to using, installing and maintaining the electric welding machine for the purpose of preventing damages such as fire, electric shock and etc from occurring. Please keep the manual for the reference in the future.

Specifications and Parameters

Rated input	115VAC, 60 hertz, 20 amps
Maximum output open-circuit voltage	28 volts DC
Rated output	90 AMPS@18volts 20%duty cycle
Wire feed rate	59 to 393 in/min (1.5-10.0m/min)
Specifications of applicable welding wire	.025”-.030” (0.6-0.8mm) solid steel .030”-.035” (0.8-0.9mm) Flux-Cored
Welding Wire Spool	8”x2” (200mmx50mm) 4”x5/8” (100mmx16mm)
Weight	54 lb (24.5 kg)
Dimensions (Length*Width*Height)	16”x9.6”x14.5” (408x244x367)

NOTE: DUTY CYCLE is welding equipment specification, which defines the number of minutes, within a given time interval, during which a given welding machine can safely produce a particular welding current. It is usually expressed as a ratio of the uninterrupted no-load duration to the total time (usually 10 minutes)

SAFETY WARNINGS AND PRECAUTIONS

WARNING: When using welder, basic safety precautions should always be followed to reduce the risk of personal injury and damage to equipment.

Read all instructions before using this welder.

Keep work area clean. Cluttered areas invite injuries.

Observe work area conditions. Do not use machines or power tools in damp or wet locations. Don't expose to rain. Keep work area well lighted. Do not use electrically powered tools in the presence of flammable gases or liquids.

Keep children away. Children must never be allowed in the work area. Do not let them handle machines, tools or extension cords.

Store idle equipment. When not in use, tools must be stored in a dry location to inhibit rust. Always lock up tools and keep them out of the reach of children.

Do not force tool. It will do the job better and more safely at the rate for which it was intended. Do not use inappropriate attachments in an attempt to exceed the tool capacity.

Use the right tool for the job. Do not attempt to force a small tool or attachment to do the work of a larger industrial tool. There are certain applications for which this welder was designed. Do not modify this welder and do not use this welder for a purpose for which it was not intended.

Dress properly. Do not wear loose clothing or jewelry as they can be caught in moving parts. Protective, flame retardant, electrically non-conductive cloths and non-skid footwear are recommended when working. Wear restrictive hair covering to contain long hair.

Use eye and ear protection. Always wear ANSI approved, arc shaded, impact safety face shield (welding helmet). Always use a full-face shield when welding. Always wear ANSI approved eyewear under face shield and while in the workplace. Wear a NIOSH approved dust mask or respirator when working around metal, chemical dusts, fumes and mists.

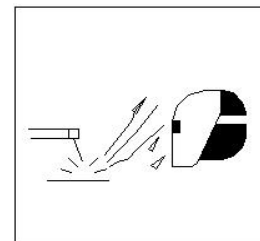

Do not over reach. Keep proper footing and balance at all times. Do not reach over or across running machines.

Maintain tools with care. Keep tools sharp and clean for better and safer performance. Follow instructions for lubricating and changing accessories. Inspect tool cords periodically and, if damaged, have them repaired by an authorized technician. The handles must be kept clean, dry, and free from oil and grease at all times.

Disconnect power. Unplug tool when not in use.

Remove adjusting keys and wrenches. Check that keys and adjustment wrenches are removed from the welder and work area before plugging in.

Avoid unintentional starting. Be sure the switch is in the off position when not in use and before plugging in. Do not carry any tool with your finger on the trigger, whether it is plugged in or not.

Stay alert. Watch what you are doing. Use common sense. Do not operate any tool when tired.

Check for damaged parts. Before using any tool, any part that appears damaged should be carefully checked to determine that it would operate properly and perform its intended function. Check for alignment and binding of moving parts; any broken parts or mounting fixtures; and any other condition that may affect proper operation. Any part that is damaged should be properly repaired or replaced by a qualified technician. Do not use the tool if any switch does not turn on and off properly.

Guard against electric shock. Prevent body contact with grounded surfaces such as pipes, radiators, ranges, and refrigerator enclosures.

Replacement parts and accessories. When servicing, use only identical replacement part. Use of any other parts will void warranty. Only use accessories intended for use with this welder. Approved accessories are available from LONGEVITY.



Do not operate tool if under the influence of alcohol or drugs. Read warning labels on prescriptions to determine if your judgment or reflexes are impaired while taking drugs. If there is any doubt, do not operate the welder.

Maintenance. For your safety, service and maintenance should be performed regularly by a qualified technician.

Use proper size and type extension cord. If an extension cord is required, it must be of the proper size and type to supply the correct current to the welder without heating up. Otherwise, the extension cord could melt and catch fire, or cause electrical damage to the welder. This welder requires use of an extension cord of 20 amps minimum capability up to 30 feet, with a wire size rated at 12 AWG. Longer extension cords require larger size wire. If you are using the welder outdoors, use an extension cord rated for outdoor use, signified by “WA” on the jacket. Performance of this welder may vary depending on condition in local line voltage. Extension cord usage may also affect welder performance.

WARNING: The warnings, cautions and instructions discussed in this instruction manual cannot cover all possible conditions and situations that may occur. It must be understood, by the operator, that common sense and caution are factors, which cannot be built into this product, but must be supplied by the operator.

ARC WELDER SAFETY WARNINGS AND PERCAUTIONS

Warning: This product, when used for welding and similar applications, produces chemicals to cause cancer and birth defects (or other reproductive harm).

Avoid electrical shock. Do not permit electrically live parts, cables, or electrodes to contact skin, clothing or gloves. Protective clothing should be hole free, dry and ANSI approved. This unit draws enough current to cause serious injury or death. Before turning the welder on, check the welder gun to be sure that there are no protruding screw heads and that all insulation is secure. Do not weld unless you are insulated from the ground and the work piece.

Avoid breathing fumes or gases. These gases can cause serious health problems. Use an active ventilation system directly above the welding area. Keep your head out of the fumes.

Avoid eye and body damage. Arc rays and infrared radiation can cause injury to the eyes and burn the skin. Wear ANSI approved eye and body protection. Do not allow viewing by visitors without proper eye and body protection.

Know proper arc welding practices. Read and understand the manufacture's instructions, as well as your employer's safety practices for arc welding.

Connect only to a code approved power source. Connect only to a grounding power source conforming to the National Electrical Code and Local Codes.

Avoid fire and explosion. Remove flammable and explosive material to a minimum of 35 feet from the welding arc to prevent welding sparks or molten metal from starting a fire. Keep a type ABC fire extinguisher within easy reach. Thoroughly clean the object being welded of any paint, grease or other foreign material.

Avoid being burned. Always wear ANSI approved welding gear: eye wear, leather gloves, leather apron and shoes.

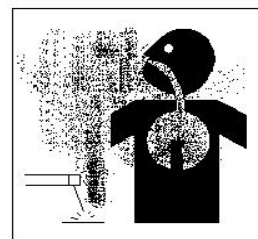
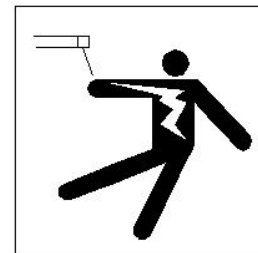

WARNING **ARC WELDING CAN BE HAZARDOUS**

WARNING: THIS WELDING MACHINE MUST BE CONNECTED TO POWER SOURCE IN ACCORDANCE WITH LOCAL ELECTRICAL CODES

WARNING: DISCONNECT POWER SOURCE BEFORE DISASSEMBLY OF THE TORCH

WARNING: THE SHIELD NOZZLE MUST BE INSTALLED PRIOR TO OPERATION OF THE TORCH

WARNING: ALL INSTALLATION, MAINTENANCE, REPAIR OPERATION OF THIS EQUIPMENT SHOULD BE PERFORMED BY QUALIFIED PERSONS ONLY IN ACCORDANCE WITH NATIONAL, STATE AND LOCAL CODES ELECTRIC SHOCK CAN KILL.

Improper use of electric arc welders can cause electric shock, injury and death! Take all precautions described in this manual to reduce the possibility of electric shock.

The MigWeld140 power switch is to be in the OFF (“O”) position when installing work cable and gun and when connecting power cord to input power.

Always wear dry, protective clothing and welding gloves and insulated footwear.

Always operate the welder in a clean, dry, well-ventilated area. Do not operate the welder in humid, wet, rainy or poorly ventilated areas.

Be sure that the work piece is properly supported and grounded prior to beginning the electric arc welding operation.

The electrode and work (or ground) circuits are electrically “hot” when the welder is on. Do not touch these “hot” parts with your bare skin or wet clothing.

Ground the work or metal to be welded to a good electrical (earth) ground.

FUMES AND GASES can be dangerous.

Do not breathe fumes that are produced by the arc welding operation. These fumes are dangerous.

Keep the head and face out of the welding fumes.

Shielding gases used for arc welding can displace air and cause injury or death. Always use enough ventilation.

WELDING SPARKS can cause fire or explosion.

Do not operate electric arc welder in areas where flammable or explosive vapors.

Always keep a fire extinguisher accessible while performing arc-welding operations.

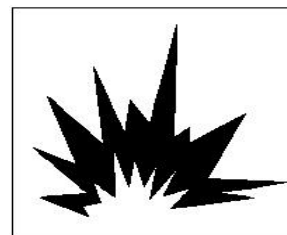

ARC RAYS can burn.

Use a shield with the proper filter and cover plates to protect your eyes from sparks and the rays of the arc when welding or observing open arc welding.

Use suitable clothing made from durable flame-resistant material to protect your skin and that of your helpers from the rays.

Protect other nearby personnel with suitable non-flammable screening or warn them not to watch the arc nor expose themselves

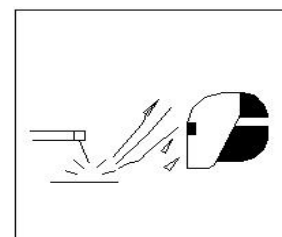

to the arc rays or to hot spatter or metal.

HOT METAL can burn

Electric arc welding operations cause sparks and hot metal to temperatures that can cause severe burns! Use protective gloves and clothing when performing any metal working operations.

Make sure that all persons in the welding area are protected from heat, sparks and ultraviolet rays. Use additional face shields and flame resistant barriers as needed.

Never touch work piece until completely cooled.

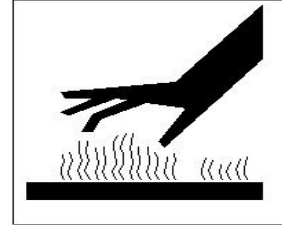

ELECTRIC AND MANGETIC FIELDS may be dangerous

The electric magnetic field that is generated during arc welding may interfere with the operation of various electrical and electronic devices such as cardiac pacemakers. Persons using such devices should consult with their physician prior to performing any electric welding operations .Exposure to electromagnetic fields during welding may have other health effects, which are not known.

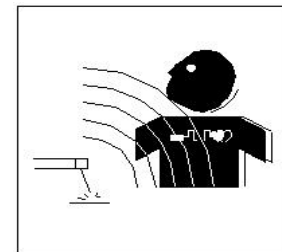

I. UNPACKING

Please check to ensure that the following components are included when unpacking (See Figure A-1)

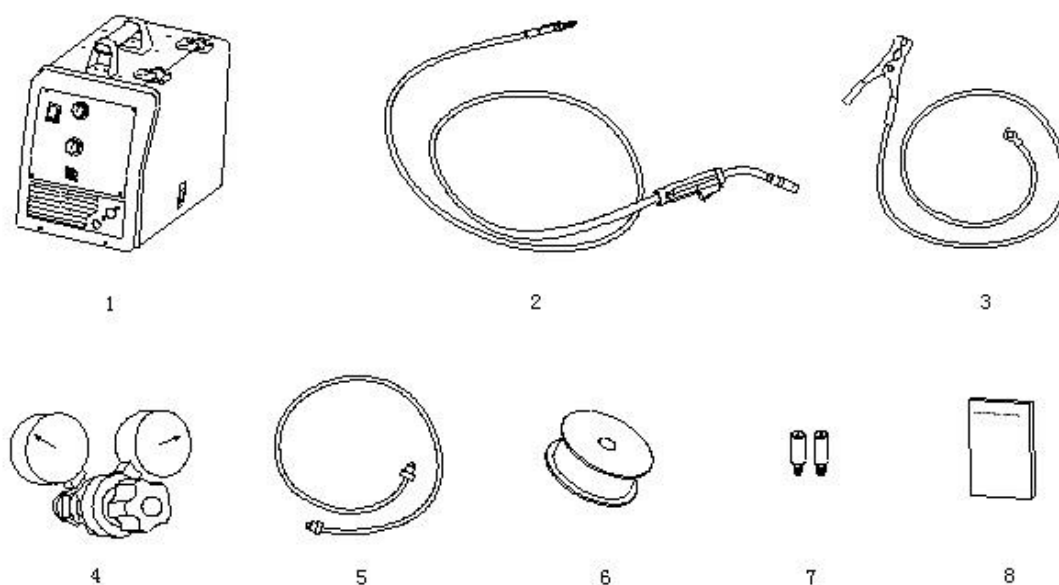
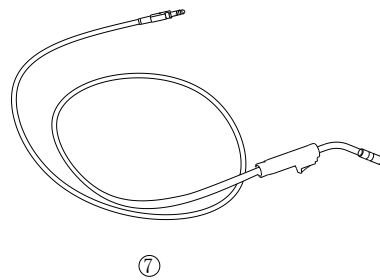
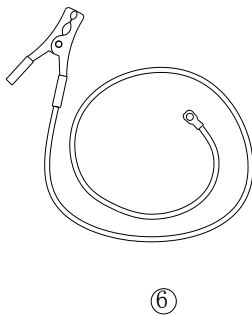
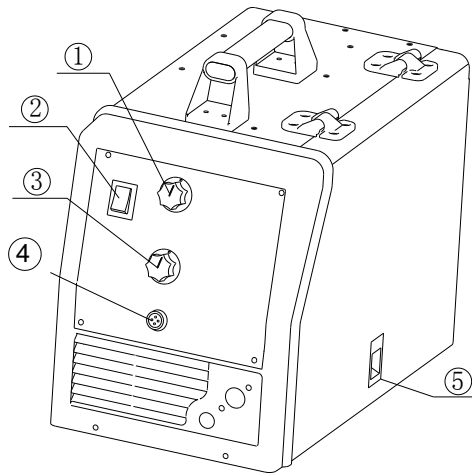

Figure A-1

- | | | |
|--|----------|------------------------------|
| 1. MigWeld 140 | 2. Torch | 3. Work clamp |
| 4. Regulator Flow Gauge | 5. Hose | 6. 2 lb. Spool .025 MIG Wire |
| 7. .030 Contact tip and .035 Contact tip | | 8. Operator's manual |

II. COMPONENTS AND CONTROLS

1. Output voltage adjust knob
2. Power switch
3. Wire feed rate adjust knob
4. Gun trigger lead connectors
5. Latch
6. Ground (work) clamp and cable
7. Welding gun and cable assembly
8. Power cord
9. Reset overload protective device - the protector will cut off the circuit if the welding machine is in excess of the maximum load, after which the switch must be manually reset.
10. Shielding gas inlet fitting
11. Wire feed gearbox
12. Wire spool spindle/shaft
13. Wing screw to fasten welding gun
14. Positive (+) and Negative (-) output terminals
15. Change switch(for optional spool gun)



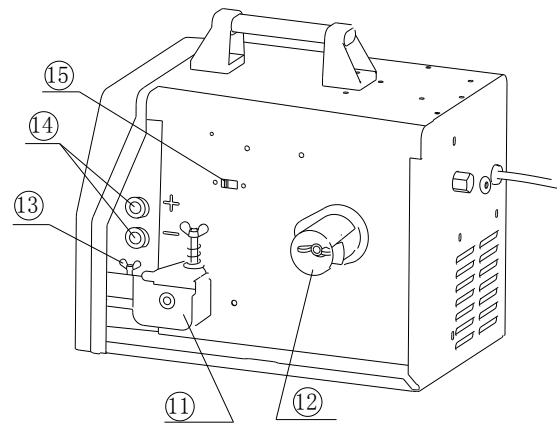
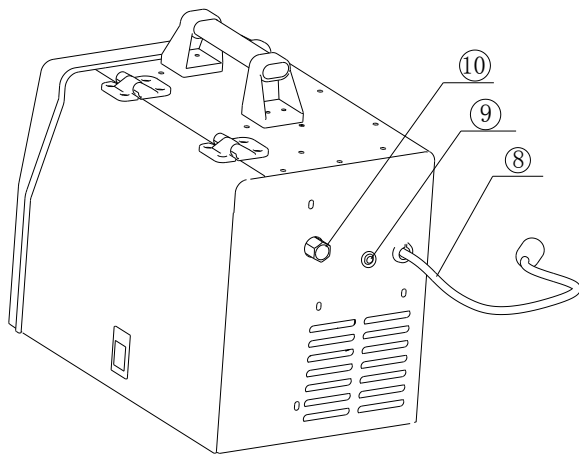

III. INSTALLATION

Grounding (work) Clamp Installation

(See Figure C-1, Figure C-2)

1. Open the right-side door of the welding machine
2. Insert the lug end of the ground clamp through access hole ②
3. Route the cable of the ground clamp around the wire feed gearbox and connect it to the negative (-) output terminal of the welding machine
4. Tighten the lug plate attached to the end of the wire with wing screw ④.

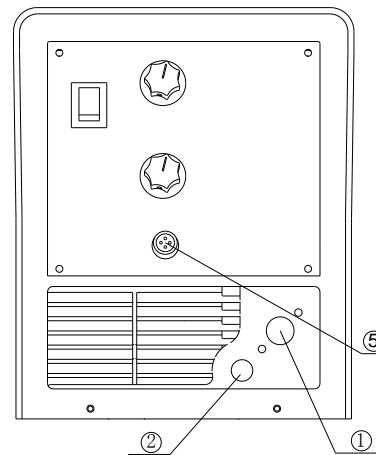

Figure C-1

NOTE: This above method of connection is GMAW. When gasless flux-cored wires are used, connect the cable of the ground clamp to the positive (+) output terminal of the welding machine. The short power cable must be removed from this lug and placed on the negative (-) terminal. (See Reference Table T-1)

Welding Gun Installation (See Figure C-1, C-2 and C-3)

There is one spool of .025" (0.6mm) solid welding wire included with the welder. The welding gun comes with a .025" (0.6mm) contact tip ⑥ installed. If .030-.035" (0.8-0.9mm) wire is to be used, change the contact tip to the appropriate size.

Connect the welding gun to the welding machine.

1. Power off the welding machine (switch is positioned at "O").
2. Plug the welding gun into the access hole ① and plug it into to the connector block. Also, thread the control wire of the welding gun through the access hole ① and inset the control wire into the gun trigger connector terminals. ⑤

3. Tighten the wing screw ③ attached to the connector block of the wire feed gearbox.
4. Make sure the Gun changing switch ⑦ is in the correct position MIG for standard welding and Spool Gun if optional gun is installed.

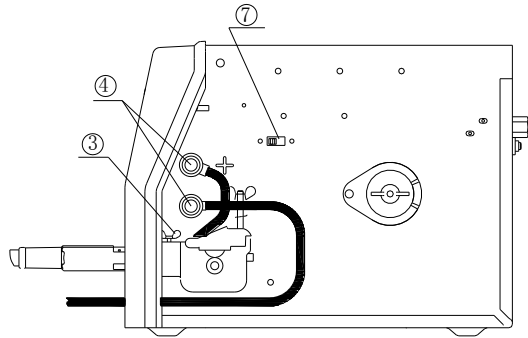

Figure C-2

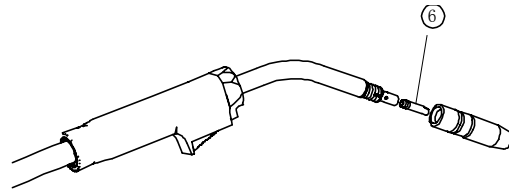

Figure C-3

Wire Drive Roll Installation (See Figure C-4)

The reversible dual groove wire drive roll attached to MigWeld140 has two wire grooves; One for .025" (0.6mm) solid welding wire and the other for .030-.035" (0.8-0.9mm) solid or flux-cored welding wire. The factory default installation is .025" (0.6mm).

In the event that .030" (0.8mm) - .035" (0.9mm) welding wires are used, the wire feed roll groove must be changed.

1. Ensure that the MigWeld 140 welding machine is powered off.
2. Unlatch the spring loaded pressure arm and open the idle roll arm. ① and lift up the idle roll arm. ②
3. Loosen the hex bolt ③ that attaches the wire drive roll.
4. Remove the wire drive roll ④ and flip the wire drive roll over so that the .030" (0.8mm) mark faces the user.
5. Reinstall by putting back the wire drive roll and tighten the hex bolt.

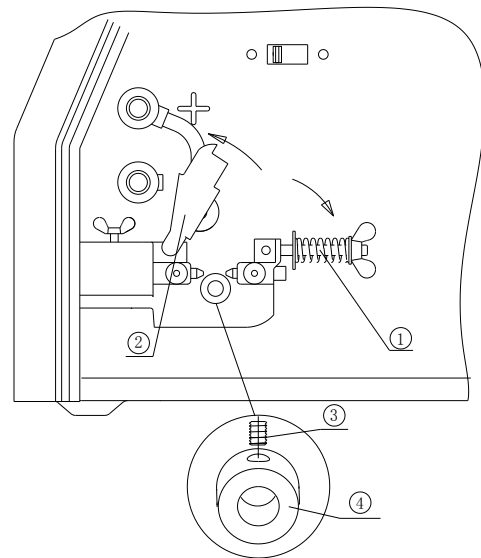

Figure C-4

Welding Wire Installation

The MigWeld140 welding machine can use wire spools up to 8" diameter (200mm) and a maximum width under 2" (50mm). If you use the smaller 4" diameter (100mm) wire spools the 2" (50mm) spindle adapter must be removed.

For installation of a 8" (200mm) welding wire spool (See Figure D-1).

Install the 8" (200mm) welding wire spool on the wire spindle ① ② making sure the wire spool spindle tab engages the hole in the wire spool. (Note: The wire spool will rotate clockwise when wire is dereeled).

For installation of a 4" diameter (100mm) welding wire spool (See Figure D-2).

The 2" (50mm) diameter spindle must be removed ②. ④ Remove the wing screw ⑤ and remove the outside plastic wire spool spindle ⑥. A 4" (100mm) diameter spool is mounted directly on a 5/8" (16mm) diameter shaft and held in place with the previously removed hardware. ⑦ (NOTE: The wire spool will rotate clockwise when wire is dereeled) Also, makes certain the start end of the welding wire, which may protrude through the side of the spool does not contact any metallic case parts

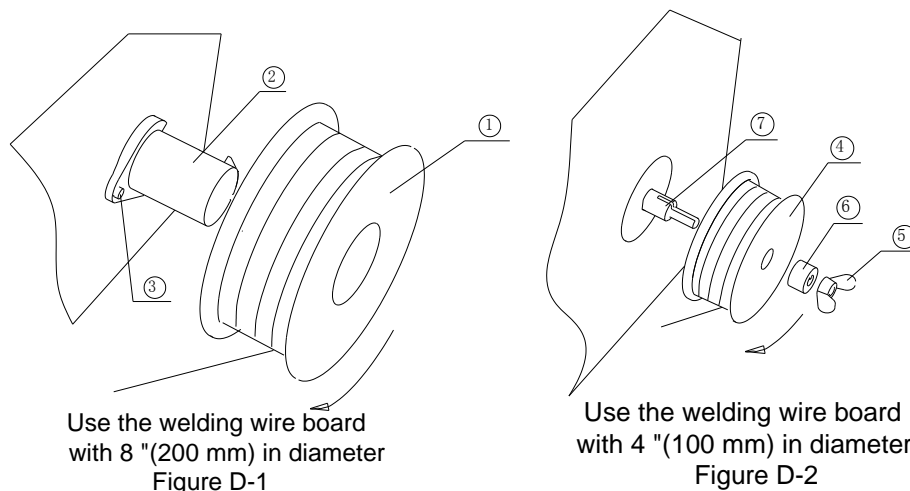

Thread the Welding Wire through the Wire Feeder by following the instructions shown as below (Figure D-3)

1. Release spring loaded pressure arm ① of the wire feeder and lift up the idle roll arm. ② (Note: the groove size in the feeding position on the drive roll matches the wire size being used, see chapter describing the installation to wire feed roll).

2. Pull out the welding wire ③ from the welding wire spool carefully; To prevent the spool from unwinding, maintain tension on the wire until after Step 5.
3. Cut off the starting end of the welding wire from the wire spool and straighten the lead section of wire from the spool approximately 4” (100mm) long.
4. Thread the welding wire through and into the hole ④ of the inlet guide tube, threading it over the wire drive roll ⑤ and into the hole ⑥ of the outlet guide tube on the gun side. Push the wire into the tailpiece of the gun approximately 6 inches.
5. Place the idle roll arm back to the operating position ② and reset the spring loaded pressure arm ① of the wire feeder.

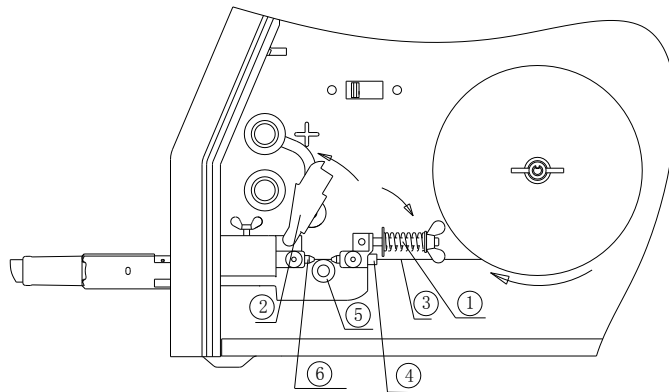
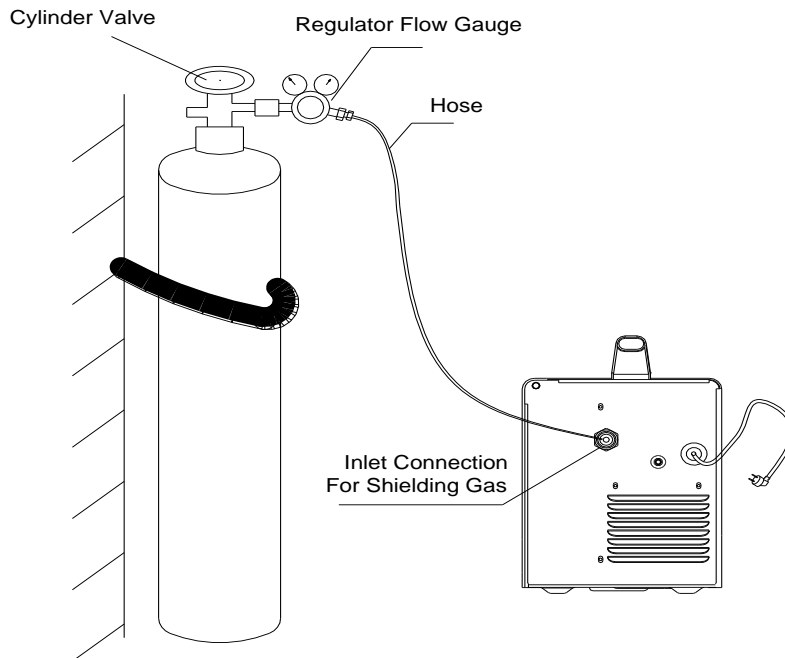

Figure D-3

Protective Gas Installation

Compressed gas cylinder containing mixed gas of, 75% Argon and 25% CO₂ should be used when using the MIG (GMAW - GAS Metal Arc Welding). The flow regulator and supply hose is included with your welder. The compressed gas can be obtained from your local welding supplier.

1. Fix the compressed gas cylinder with a chain, or other method to the wall or other securing device, to prevent the cylinder of falling.
2. After securing, remove cylinder cap if there is one on your cylinder.
3. Install flow regulator (CGA-580) to the supply valve on the cylinder and tighten with wrench.
4. Install one end of the gas supply hose into the outlet of the flow regulator and tighten. Connect the other end of the hose to the gas inlet located at the rear of the MigWeld140 welding machine (The connector nipple 5/8-18 adapts to CGA-032). Ensure that the hose has no twisting or knotting.
5. Slowly turn on the gas cylinder valve.
6. Depress gun trigger switch and adjust the flow regulator to 25-30 cubic ft per hour (CFH), (12-14 l/min).
7. Shut off the valve of the gas cylinder. Depress gun trigger to release the gas in system. Power off MigWeld140, when welding process is finished.
8. NOTE: Always keep the valve of the gas cylinder closed when not in use.



Welding Operations

1. Make sure power is off on the MigWeld140 Welding Machine
2. Remove nozzle and contact tip
3. Power on MigWeld140 Welding Machine
4. Straighten welding gun
5. Hold trigger of the welding gun (depressing trigger will feed the welding wire into the welding gun.) When the welding wire is exposed at the outlet side of the welding gun, release the trigger switch of the welding gun
6. Make sure power is off on the MigWeld140 Welding Machine
7. Reinstall the nozzle and contact tip
8. Cut off the welding wire 1/4-1/2" (6-10mm) away from the tip end of the welding gun and get ready for welding

Welding Process

1. Please refer to the welding manual when selecting welding wires and protective gases based on the metal thickness.
2. Please refer to “Welding Control Guide” that is located inside the welding machine door for the output voltage and wire feed rates.
3. Inspect output polarity according to the welding wire being used and ensure whether or not shielding gases are needed.
4. Connect the ground (work) clamp to the piece(s) to be welded; there should be a good connection for the ground (work) clamp to the piece(s).
5. The welding gun should have free movement in the area of the piece(s) to be welded.
6. Power on the MigWeld140 Welding Machine
7. Pull down welding protective helmet, press the trigger of the welding gun and begin to weld. Keep the contact tip of the welding gun at around 3/8” to 1/2” (10-13mm) away from piece(s) to be welded.
8. Release trigger of the welding gun and the welding is stopped.
9. After welding, turn off valve of the compressed gas cylinder (if gas is used) and then press trigger of the welding gun to release compressed gas in system. Finally, power off the MigWeld140 Welding Machine.

Optional Spool Gun - Contact your local LONGEVITY dealer for correct Spool Gun part number.

Your MigWeld140 has a factory installed option to allow you to install and operate a hand held spool gun. This will allow you to do welding of both Aluminum and Steel. To install the spool gun you must first power down the welder, remove the standard MIG gun and install the Spool Gun using the same installation process as described on page 9. You must move the Change Switch (7) from MIG to Spool Gun. This will disable the drive system of the welder and enable the Spool Gun’s drive system. Reference the owner’s manual of the Spool Gun for operating procedures and instructions of the Spool Gun.

SUGGESTED SETTINGS FOR WELDING

PROCESS	WELDING WIRE	SHIELDING GAS	STEEL THICKNESS													
			24 ga .024 in 0.60mm	22 ga .030 in 0.80mm	20 ga .036 in 1.0mm	18 ga .048 in 1.2mm	16 ga .060 in 1.6mm	14 ga .075 in 2.0mm	12 ga .105 in 2.5mm	10 ga .135 in 3.5mm	3/16 in 5.0mm	1/4 in 6.0mm	5/16 in 8.0mm			
MIG DC (+)	.025 in (0.6mm) DIA. SOLID STEEL WIRE	CO ₂	E-2.5	E-3	F-4	F-4.5	G-5	J-6	---	---	---	---	---	---	---	---
		C20 or C25 (75-90% ARGON, 25-20% O2)	C-2.5	D-3	E-4	F-5.5	G-6.5	H-7	J-8	---	---	---	---	---	---	---
GASLESS FLUX- CORED DC (-)	.030 in (0.8mm) DIA. SOLID STEEL WIRE	CO ₂	---	E-3	F-3.5	F-4	G-4.5	H-4.5	---	---	---	---	---	---	---	---
		C20 or C25 (75-90% ARGON, 25-20% O2)	---	D-3	E-3.5	E-4	F-4.5	G-4.5	J-5.5	---	---	---	---	---	---	---
	.035 in (0.9mm) DIA. Flux Core	NONE	---	---	C-1	D-1.5	E-2	F-2.5	G-3	G-3	G-3	G-3	G-3	G-3	G-3	G-3

Note: (1) Maximum output setting- Do not use unless connected to a 25 amp branch circuit.

OUTPUT POLARITY		DRIVE ROLL ORIENTATION	
MIG DC (+)		INSTALL DRIVE ROLL WITH THE REQUIRED STENCILED SIZE FACING OUT	
		MIG DC (+)	GASLESS FLUX-CORED DC (-)
GASLESS FLUX-CORED DC (-)		.025 in (0.6mm) DIA. SOLID STEEL WIRE	.035 in (0.9mm) DIA. Flux Core

V. Overload Protection

Overload protection for power supply to welding

The MigWeld140 Welding Machine is equipped with a circuit breaker and a thermostat, which protects the machine from damage if maximum output is exceeded. The circuit breaker button will extend out when tripped. The circuit breaker must be manually reset. Wait for several minutes while the welding machine cools down and reset the circuit breaker button.

Thermal Protection

The MigWeld140 has a rated output duty cycle of 20%. If the duty cycle is exceeded, a thermal protector will shut off the output until the machine cools to a reasonable operating temperature. This is an automatic function and does not require user intervention. The fan continues to run during cooling.

Overload Protection to Wire feeder

The MigWeld140 model has two automatic circuits to protect the motor of the wire drive.

LONGEVITY® Global, Inc. thanks you for your purchase and the opportunity to be able to serve you. If, after reviewing this manual, you have any problems in setting up or operating your machine, contact us at help@longevity-inc.com.

LONGEVITY® Global, Inc.

Toll-Free 1-877-LONG-INC / 1-877-566-4462

Website: www.longevity-inc.com

Sales: sales@longevity-inc.com

Customer Service: help@longevity-inc.com

Dealers: dealers@longevity-inc.com

Please join our welding forums to share welding tips and tricks, to receive useful information from customers who also use our products, and to be a part of the LONGEVITY® welding community at www.freeweldingforum.com

For the coolest LONGEVITY sponsored race teams plus a complete racing forum that covers everything from Drag Racing to RC Car Racing, please check out www.longevity-racing.com!

Enjoy your new welding machine from LONGEVITY! Thanks again!

Free Manuals Download Website

<http://myh66.com>

<http://usermanuals.us>

<http://www.somanuals.com>

<http://www.4manuals.cc>

<http://www.manual-lib.com>

<http://www.404manual.com>

<http://www.luxmanual.com>

<http://aubethermostatmanual.com>

Golf course search by state

<http://golfingnear.com>

Email search by domain

<http://emailbydomain.com>

Auto manuals search

<http://auto.somanuals.com>

TV manuals search

<http://tv.somanuals.com>