



TRANE[®]

Installer's Guide

Home Standby Generator

- TR15REG-DB (15Kw single-phase)
- TR20REG-DB (20Kw single-phase)
- TR20REG-DB-3 (20Kw three-phase)

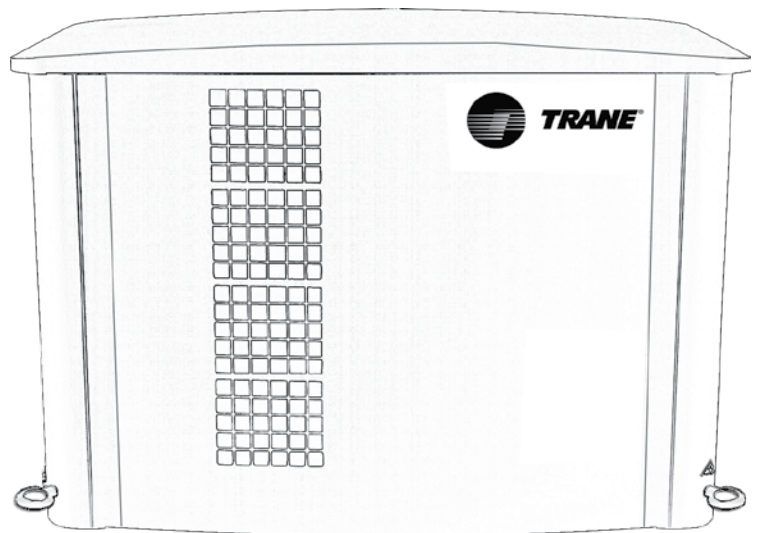

Note: "Graphics in this document are for representation only.
Actual model may differ in appearance."

⚠ SAFETY INSTRUCTIONS

Only qualified personnel should install and service the equipment. The installation, starting up, and servicing of home standby generator equipment can be hazardous and requires specific knowledge and training. Improperly installed, adjusted or altered equipment by an unqualified person could result in death or serious injury. When working on the equipment, observe all precautions in the literature and on the tags, stickers, and labels that are attached to the equipment.

Installation, Maintenance and Repair Manual

For licensed authorized personnel only.

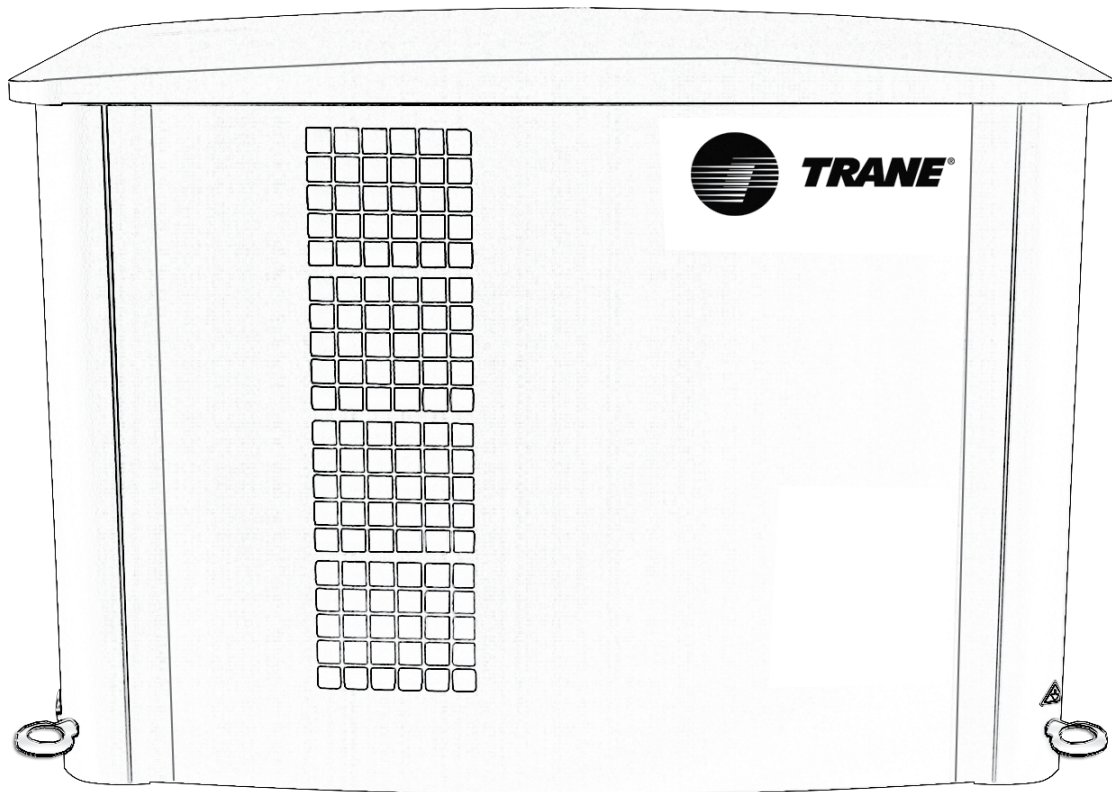

TR15REG-DB

TR20REG-DB

TR20REG-DB-3

Read all instructions carefully before installation



WARNING: Only qualified technicians and contractors are to perform installation

NOT INTENDED FOR USE IN CRITICAL LIFE SUPPORT APPLICATIONS!

Save all instructions!

It is recommended that the Serial Number # be recorded for future warranty, parts and service needs. It can be located, inside the back-panel on the stamped ID plate or on the outside of original shipping carton. This system requires a password to unlock controller for operation and programming. Call 844-367-5660 for password.

Engine ID # _____

Controller Password _____

Table Of Contents

Introduction	4
Operation & Maintenance	5
Safety Rules and Common Hazards	5
Electrical Hazards	7
Fire Hazards	7
Explosion Hazards	8
Standards Index	8
Uncrating and Initial Inspection	9
NEC Requirements	9
First Step	10
Location and Site Preparation	10
Prestart & Preparation	12
Lubrication System	12
Cooling System	13
Fuel Selection and Conversion from NG to LPG	13
Installing and Connecting Gas Lines	14
External Power Connections and Wiring Diagram	15
Battery Connection	16
Generator Electrical Connections	17
Key Function Operations	18
Manual Stop / Start	19
Auto Stop / Start	19
Parameter Settings	20
Controller Wiring Diagram	22
SmartGen Digital Controller Specifications	23
ATS Installation and Wiring Diagram	26
Testing	29
Circuit Coverage	30
Electrical Connections	30
Funcional Testing	31
Maintenance of Generator	33
Generator Circuit Diagram	38
Common Fault Readings and Troubleshooting	39
Engine, Primary Parts and Structure	45
Generator Alternator and Specifications	48
Common Formulas	50
Maintainence Parts	51
Additional Troubleshooting Procedures	52

INTRODUCTION

Thank you for choosing a Trane standby generator. This manual provides you with extremely important information about installation, operation and maintenance of the generator system. If you have any questions about our products, parts, propane products, warranty or service questions, or need professional installation services, please call 844-367-5660.



Before using this generator, you are advised to read the manual in its entirety and fully understand its contents.

This generator utilizes an automotive 998cc, 4-cylinder liquid cooled, gas engine. The design was selected because it has been in service for over 20 years with millions of dependable hours and miles in various applications. This ensures and provides the performance needed for, long term, dependable power output. Through constant development, this unit has advantages that a number of similar sized products do not offer. Such as, automotive grade engine, liquid-cooled radiator system, powder coated steel/composite exterior housing, automotive grade muffler for silent operation, electronic speed control system, 200amp automatic transfer switch (ATS) included, Sinci - low distortion alternator for all electronic devices, SmartGen - intelligent control system in four programmable languages and multi-function capability's, GSM digital monitoring system (optional), Cold weather kit for extreme cold temperature starts (optional). For optional equipment contact our customer service department at 844-367-5660.

Due to continual improvements and a commitment to offer the latest technology, service and warranty, this manual may differ slightly from the actual object, contact Trane with any questions:

844-367-5660

	 WARNING
	<p>This product may contain a chemical known to the State of California to cause cancer or birth defects or other reproductive harm.</p> <p>Este producto puede contener un producto químico conocido en el estado de California como causantes de cáncer o de defectos de nacimiento u otros daños reproductivos.</p> <p>Ce produit peut contenir un produit chimique connu dans l'État de Californie pour causer le cancer ou des malformations congénitales ou autres.</p>

	 WARNING!
	<p>Using a generator inside CAN KILL YOU IN MINUTES.</p> <p>Generator exhaust contains carbon monoxide. This is a poison that you cannot see or smell.</p> <p>NEVER use inside a home or garage, EVEN IF doors and windows are open.</p> <p>Only use OUTSIDE and far away from windows, doors and vents.</p> <p>Avoid other generator hazards, READ MANUAL BEFORE USE</p>

	 ¡ADVERTENCIA!
	<p>Usar un generador en el interior puede MATAR EN CUESTIÓN DE MINUTOS.</p> <p>Escape del generador contiene monóxido de carbono. Este es un veneno que no se puede ver ni oler.</p> <p>No utilice nunca dentro de la casa o en el garaje, incluso si las puertas y ventanas están abiertas.</p> <p>Utilice sólo fuera y lejos de las ventanas, puertas y aberturas.</p> <p>Evitar otros peligros generador, LEER EL MANUAL ANTES DE USAR</p>

	 AVERTISSEMENT!
	<p>En utilisant un générateur à l'intérieur PEUT VOUS TUER EN QUELQUES MINUTES.</p> <p>D'air du générateur contient du monoxyde de carbone. C'est un poison qui vous ne pouvez pas voir ou sentir.</p> <p>N'utilisez jamais l'intérieur d'une maison ou garage, même si les portes et fenêtres sont ouvertes.</p> <p>Utilisez uniquement l'extérieur et loin des fenêtres, portes et évents.</p> <p>Éviter d'autres dangers du générateur, LIRE LE MANUEL AVANT UTILISATION</p>



In case of an emergency, the owner operator is responsible for proper and safe use of the electric generator system. The manufacturer strongly suggest that the owner operator read the Owner's Manual in its entirety and understand all operating instructions before using the electrical standby generator. If not properly adhered to, damage can occur to the system causing fire, electrical shock and even death. The manufacturer also strongly recommends instructing other users to properly start/stop and operate the unit in time of need.

Operation and Maintenance

It is the sole responsibility of the owner to periodically service and maintain safe operating conditions. Routinely inspect the system for all fluid levels, fluid leaks, loose belts, and unusual noises from normal operation. If this is observed, contact your installer, local service provider or our Toll Free 844-367-5660 number for help. To insure your system is always in top condition, contact us for an authorized service center near you for repairs and extended service agreements. This will give you the peace of mind that your investment will always be in top condition when an emergency arises.

Standard maintenance service and the replacement of parts are the responsibility of the owner/operator and, as such, are not considered defects in materials or workmanship within the terms of the warranty. Personal operating habits and usage contribute to the need for maintenance and service. Proper maintenance and care of the generator ensures a minimum number of problems and keep operating expenses at a minimum. Talk to your Installing Dealer about maintenance Plans.



Safety Rules



Save These Instructions – The manufacturer suggests that these rules for safe operation be copied and posted near the unit's installation site. Safety should be stressed to all operators and potential operators of this equipment.

Study these SAFETY RULES carefully before installing, operating or servicing this equipment. Become familiar with this Owner's Manual and with the unit. The generator can operate safely, efficiently and reliably only if it is properly installed, operated and maintained. Many accidents are caused by failing to follow simple and fundamental rules or precautions.

The manufacturer cannot anticipate every possible circumstance that might involve a hazard. The warnings in this manual, and on tags and decals affixed to the unit are, therefore, not all-inclusive. If using a procedure, work method or operating technique the manufacturer does not specifically recommend, ensure that it is safe for others. Also make sure the procedure, work method or operating technique utilized does not render the generator unsafe.



- Despite the safety design features of this generator, operating this system improperly, and neglecting routine maintenance can cause possible injury or death. Allow only certified and licensed personnel to install, operate and maintain this system.
- Potentially lethal voltages are generated by these generators. Make sure all steps are taken to render the machine safe before attempting to work or service the generator system.
- Parts of the generator are rotating at high speeds and are hot during operation. Exercise care near operating generators.
- Installation must always comply with applicable local and state codes, standards, laws and regulations.

COMMON HAZARDS

- A running generator gives off carbon monoxide, and odorless, colorless poison gas. Breathing in carbon monoxide can cause headaches, fatigue, dizziness, nausea, vomiting, confusion, fainting, seizures or death.
- The engine exhaust fumes contain carbon monoxide, which can be DEADLY. This dangerous gas, if inhaled in sufficient concentrations, can cause unconsciousness or even death. Do NOT alter or add to the exhaust system or do anything that might render the system unsafe or in noncompliance with applicable codes and standards.
- Install a battery operated carbon monoxide alarm indoors, according to manufacturer's instructions and recommendations.
- Adequate, unobstructed flow of cooling and ventilating air is critical to correct generator operation. Do not alter the installation or permit even partial blockage of ventilation, as this can seriously affect safe operation of the generator. The generator MUST be installed and operated outdoors only.
- Keep hands, feet, clothing, etc., away from drive belts, fans, and other moving or hot parts. Never remove any drive belt or fan guard while the unit is operating.
- When working on this equipment, remain alert at all times. Never work on the equipment when physically or mentally fatigued.
- Inspect the generator regularly, and contact the nearest Dealer for parts needing repair or replacement.
- Before performing any maintenance on the generator, disconnect battery cables to prevent accidental start up. Disconnect the cable from the battery post indicated by a NEGATIVE, NEG or (-) first, then remove the POSITIVE, POS or (+) cable. When reconnecting the cables, connect the POSITIVE cable first, the NEGATIVE cable last.
- Never use the generator or any of its parts as a step. Stepping on the unit can stress and break parts, and may result in dangerous operating conditions from leaking exhaust gases, fuel leakage, oil leakage, etc. NEVER STAND ON UNIT!

ELECTRICAL HAZARDS

- Generators covered by this manual produce dangerous electrical voltages and can cause fatal electrical shock. Utility power delivers extremely high and dangerous voltages to the transfer switch as does the standby generator when it is in operation. Avoid contact with bare wires, terminals, connections, etc., while the unit is running. Ensure all appropriate covers, guards and barriers are in place, secured and/ or locked before operating the generator. If work must be done around an operating unit, stand on an insulated, dry surface to reduce shock hazard. **It is required that a wooden pallet and rubber mat placed on top, be used to, avoid potential and possible shock.**
- Do not handle any kind of electrical device while standing in water, while barefoot, or while hands or feet are wet. DANGEROUS ELECTRICAL SHOCK MAY RESULT.
- The National Electrical Code (NEC) requires the frame and external electrically conductive parts of the generator to be connected to an approved earth ground. Local electrical codes also may require proper grounding of the generator electrical system. Refer and adhere to all state and local electrical codes.
- After installing this home standby electrical system, the generator may crank and start at any time without warning. When this occurs, load circuits are transferred to the STANDBY (generator) power source. To prevent possible injury if such a start and transfer occur, always set the generator's AUTO/OFF/MANUAL switch to its OFF position before working on equipment and remove the fuse from the generator control panel.
- In case of accident caused by electric shock, immediately shut down the source of electrical power by pushing the emergency stop switch located on the outside of unit. Use a non-conducting implement to push the emergency stop switch if possible. If it is not possible, attempt to free the victim from the live conductor. AVOID DIRECT CONTACT WITH THE VICTIM. Use a non-conducting item, such as a dry rope or wooden board, to free the victim from the live conductor. If the victim is unconscious, apply first aid and get immediate medical attention.
- Never wear jewelry when working on this equipment. Jewelry can conduct electricity resulting in electric shock, or may get caught in moving components causing injury.

POSSIBLE FIRE HAZARDS!

- For fire safety, the generator must be installed and maintained properly. Installation must always comply with applicable codes, standards, laws and regulations. Adhere strictly to local, state and national electrical and building codes. Comply with all regulations the Occupational Safety and Health Administration (OSHA) has established. Also, ensure that the generator is installed in accordance with the manufacturer's instructions and recommendations. Following proper installation, do not alter an installation that might render the unit in noncompliance with the aforementioned codes, standards, laws and regulations.
- Keep a fire extinguisher near the generator at all times. Extinguishers rated "ABC" by the National Fire Protection Association are appropriate for use on the standby electrical system. Keep the extinguisher properly charged and be familiar with its use. Consult the local fire department with any questions pertaining to fire extinguishers.

POSSIBLE EXPLOSION HAZARDS!

- Do not smoke around the generator. Wipe up any fuel or oil spills immediately. Ensure that no combustible materials are left in the generator compartment, or on or near the generator, as FIRE or EXPLOSION may result. Keep area surrounding the generator clean and free from debris.
- Gaseous fluids such as natural gas (NG) and liquid propane gas (LPG) are extremely EXPLOSIVE. Install the fuel supply system according to applicable fuel-gas codes. Before placing the standby electric system into service, fuel system lines must be properly purged and leak tested according to applicable code. After installation, inspect the fuel system periodically for leaks. Make sure there are no gas leaks, use digital gas detector.

STANDARDS INDEX

In the absence of pertinent standards, codes, regulations and laws, the published information listed below may be used as installation guide for this equipment.

- NFPA No. 37, STATIONARY COMBUSTION ENGINES AND GAS TURBINES, available from the National Fire Protection Association, 470 Atlantic Avenue, Boston, MA 02210.
- NFPA No. 76A, ESSENTIAL ELECTRICAL SYSTEMS FOR HEALTH CARE FACILITIES, available same as Item 1.
- NFPA No. 54, NATIONAL FUEL GAS CODE, available same as Item 1.
- NFPA No. 58, AMERICAN NATIONAL STANDARD FOR STORAGE AND HANDLING OF LIQUEFIED PETROLEUM GAS, available same as Item 1.
- NFPA No. 70, NFPA HANDBOOK OF NATIONAL ELECTRIC CODE, available same as Item 1.
- Article X, NATIONAL BUILDING CODE, available from the American Insurance Association, 85 John Street, New York, N.Y. 10038.
- AGRICULTURAL WIRING HANDBOOK, available from the Food and Energy Council, 909 University Avenue, Columbia, MO 65201.
- ASAE EP-3634, INSTALLATION AND MAINTENANCE OF FARM STANDBY ELECTRICAL SYSTEMS, available from the American Society of Agricultural Engineers, 2950 Niles Road, St. Joseph, MI 49085.
- NFPA No. 30, FLAMMABLE AND COMBUSTIBLE LIQUIDS CODE, available same as Item 1.
- AGRICULTURAL WIRING HANDBOOK, available from the Food and Energy Council, 909 University Avenue, Columbia, MO 65201.
- ASAE EP-3634, INSTALLATION AND MAINTENANCE OF FARM STANDBY ELECTRICAL SYSTEMS, available from the American Society of Agricultural Engineers, 2950 Niles Road, St. Joseph, MI 49085.
- NFPA No. 30, FLAMMABLE AND COMBUSTIBLE LIQUIDS CODE, available same as Item 1.



Only qualified electricians or contractors should attempt such installations, which must comply strictly with applicable local and state codes, standards and regulations.

Uncrating and Initial Inspection

After uncrating, carefully inspect the contents for any visible damage. Do not tilt the machine more than 30 degrees. Try to avoid transporting on uneven ground. Violent shaking and vibration during transportation may affect the unit.

- This standby generator set is ready for installation with a weather protective enclosure that is intended for outdoor installation use only!
- This ETL listed standby generator set may be packaged with an automatic transfer switch (ATS).
- This ETL listed, 2-pole switch is rated at 200 AC amperes at 250 volts maximum. The 200 Amp transfer switch is rated for indoor or outdoor use.



If this generator is used to power electrical load circuits normally powered by a utility power source, it is required by code to install a transfer switch. The transfer switch must effectively isolate the electrical system from the utility distribution system when the generator is operating (NEC 700, 701 & 702). Failure to isolate an electrical system by such means will result in damage to the generator and also may result in injury or death to utility power workers due to backfeed of electrical energy.

If any loss or damage is noted at time of delivery, have the person(s) making the delivery, note all damage on the freight bill or affix their signature under the consignor's memo of loss or damage.

If a loss or damage is noted after delivery, separate the damaged materials and contact the carrier for claim procedures.

"Concealed damage" is understood to mean damage to the contents of a package that is not in evidence at the time of delivery, but is discovered later.

To properly open the cover, press down on the center top lip and release the latch with key. If pressure is not applied from the top, the roof may appear stuck. Always verify that the lock is released before attempting to lift the roof.

NEC REQUIREMENTS

Local code enforcement may require that AFCIs (Arc Fault Circuit Interrupters) be incorporated into the transfer switch distribution panel. The Transfer Switch provided will accept AFCI's.

Siemens P/N. Q115AF - 15A or Q120AF - 20A can be obtained from a local electrical wholesaler and will simply replace any of the single pole circuit breakers supplied in the Transfer Switch distribution panel.

First Step!

Contact your local building inspector or City Hall to be aware of all federal, state and local codes that could impact the installation. Secure all required permits before starting the project.

Carefully read and follow all procedures and safety precautions detailed in the installation guide. If any portion of the installation manual, technical manual or other factory-supplied documents is not completely understood, contact your local authorized dealer for assistance.

It is extremely important to comply with all relevant NEC, NFPA and OSHA standards as well as all federal, state and local building and electrical codes.

As with any generator, this unit must be installed in accordance with current NFPA 37 and NFPA 70 standards as well as any other federal, state, and local codes for minimum distances from other structures. As a minimum distance, use 24 inches from home or building.

GENERATOR LOCATION AND SITE PREPARATION



1. Place concrete pad as close as possible to both breaker box and fuel supply. **IMPORTANT! Pre-wired control harness located inside ATS is 9 feet long. Call for longer 20ft, 50ft and 80ft harnesses.**

Leave adequate room around the area for service access. You must CHECK LOCAL CODE for proper distance between generator and structure! Check local code, and place high enough to keep rising water from reaching the generator. Select an open space that will provide adequate and unobstructed air-flow.

Electrical interference with such items as, cell phones, computers, TV's and other electrical devices and equipment can occur when standing close or next to running standby system.

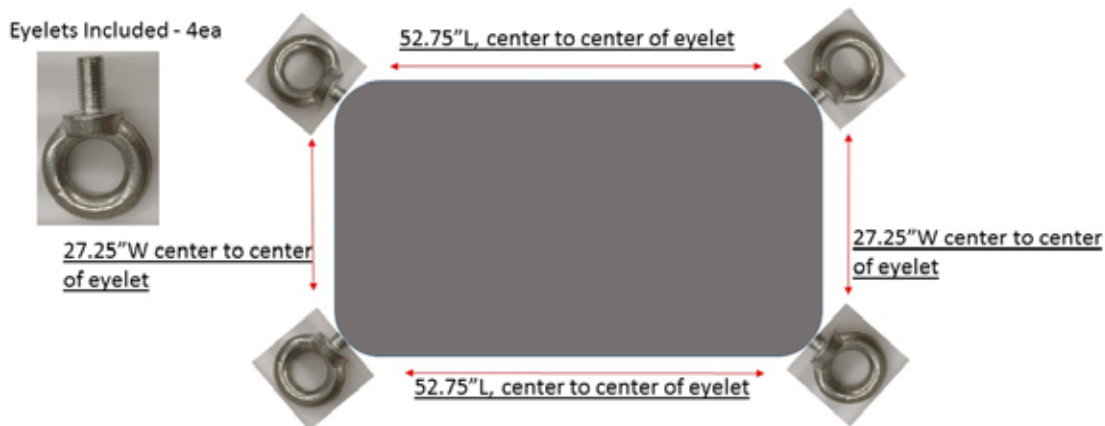

It is recommended that a concrete pad be utilized that is 3 to 4 inches past each eyelet on each side. Pad depth 4".

It is strongly advised that you use provided eyelet bolts for lifting and anchoring system to a concrete pad, center to center of eyelets, 52.75"L X 27.25"W.
Just Base Cabinet Measurements – 29"W X 52.75"L

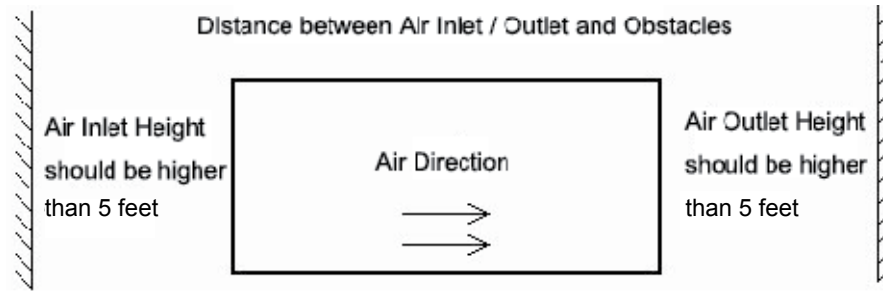

2. Place the unit so air vents won't become clogged with leaves, grass, snow or debris. Make sure exhaust fumes will not enter the building through eaves, windows, ventilation fans or other air intakes. Build a rectangular form out of 2"X6 wooden studs. Dig an area approximately 4 inches deep and about 4 to 6 inches, longer and wider than the footprint of the generator. Place wooden frame in hole leaving approximately 2" above ground. Place polyurethane film in the bottom and fill with pea gravel or crushed stone along with rebar reinforcement. Level and pack gravel or stone evenly. The concrete pad is now ready to be poured. When pouring concrete, set grade 5 anchor bolts in wet concrete based on the foot print of generator lining up with holes on the base of the unit. Once complete level and finish concrete pad and allow to set for 48 hours.
3. Inspect packaging and generator for exterior shipping damage. Remove all packaging material.
4. Make sure the lifting equipment to be used has sufficient capacity to safely handle the weight of the generator (TR20REG-DB created gross weight 850lbs). Use nylon lifting straps and connect them to the lifting eyebolts on each corner of the base frame to avoid damage to the enclosure (lifting eyebolts included) Make sure straps are lifting straight upward and do not pinch lid! Set generator into place and anchor tightly to concrete pad using grade 5 hardware.
5. When using forklift, you have to ensure that forks are wide enough to lift the unit from the bottom. Fully insert the fork legs completely through the bottom of the machine. Pay attention to the machine components avoiding damage from the bottom, lift and set flat on concrete pad. Avoid tilting and dropping generator. Handle with care.
6. Center the generator onto pad so that there is equal distance between the generator on all four sides, making sure, the generator is level within 1/16" inch.
7. **IMPORTANT!** Connect an approved ground strap to the grounding lug on the base of frame and to an approved earth ground or grounding rod as specified by local code and regulations.

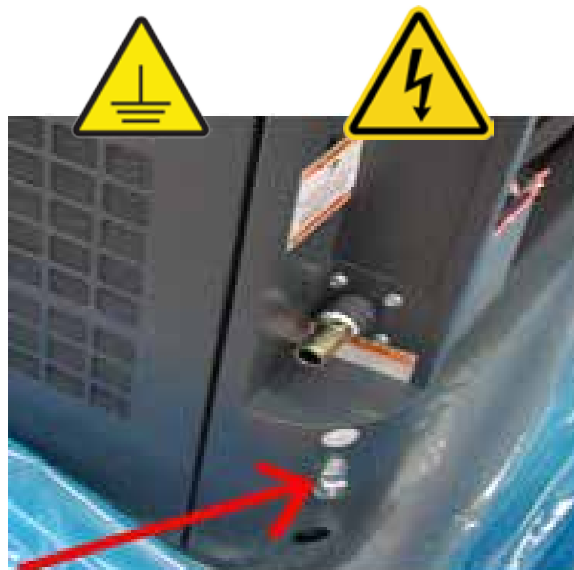

DO THIS STEP FIRST BEFORE ANY OTHER INSTALLATION PROCEDURE IS PERFORMED!

! DANGER	
	<p>Hazardous voltage Backfeed to the utility system can cause property damage, severe injury, or death. If the generator set is used for standby power, install an automatic transfer switch to prevent inadvertent interconnection of standby and normal sources of power supply.</p>

Engine Prestart and Preparation

All necessary installation and maintenance must be conducted and performed by authorized licensed personnel.

Before starting engine for the first time, engine oil and radiator coolant must be added. An initial fluid inspection and pre-check is recommended before starting genset for the first time or when unit has been in operation for over 20 hours. It can also be used as a quick review of all fluids. Check all of the following items before running system for the first time.



1. Lubrication System

IMPORTANT NOTE! Unit is not shipped with engine oil or coolant from Factory!!

After installment of generator, fill engine with recommended oil weight based on ambient temperature shown below and add radiator coolant. Prior to initial startup, replace all service panels and close lid. Start engine and allow 10 minutes for system to warmup. After this has been performed remove service panels rise lid and check for any leaks or drips. If found, tighten lose hoses, clamps or plugs. Recheck all fluid levels and top off as necessary.

Engine Oil. The unit is not shipped with oil from factory!!! Only use high-quality Synthetic motor detergent oil "Classified with SAE viscosity ratings. Fill with the recommended amount of oil as specified.

Overfilling or under filling can cause damage to the engine. Use the following recommended or similar type engine oil.

Temperature	Mobil 1 Synthetic Oil or equivalent recommended
Below 32° F (0° C)	SAE 0W-40
32° to 80° F (-1° to 27° C)	SAE 10W-40
Above 80° F (27° C)	SAE 15W-50

- Place funnel in engine oil inlet.
- First time operation will require 4 liters or (4.25qts) of oil
- Check oil gauge dipstick regularly, oil level should be kept between top and bottom lines, at all times. It is preferred to be at the top mark but not over.



Fuel Oil Level Mark

Engine Oil

2. Cooling System

Use only automotive grade antifreeze and distilled water in cooling system. Do not use tap water, or water that contains salt or alkalis! Using non-distilled water creates scale in the radiator, causing corrosion and premature wear.



You must check and maintain all fuel, lubricant and coolant levels. Not doing so will accelerate and shorten the life of the standby system. Attention must be paid to all fluid systems and annually serviced by an authorized service provider or call 844-367-5660 for assistance.

Converting from Natural Gas (NG) to Liquid Propane Gas (LPG)

Most generators are configured for natural gas operation at the factory. Switching over to LP Vapor is a simple procedure.

Fuel Conversion

These fuels are flammable and explosive materials. Do not operate around open flames.



1. When using LPG as fuel:

- Prior to each operation, you should check various components and handle any loose fasteners. Check if there's any fuel leakage around pipes and connections by utilizing a digital gas leak detector (soapy water can be used). Service any leakage immediately!
- When changing fuel supply, close gas valve supply and allow fuel in the fuel line to burn off. Then turn off main power breaker on standby control panel.
- After fuel supply conversion from LPG to NG replacement, use gas leak detector for any leakage.
- Periodically check the pressure reducing valve, if the solenoid valve sealing pad is deformed. You must first close the manual valve on the fuel supply. Then start the engine. Use up the gas in the fuel line before you remove the solenoid valve and other parts, if not, this will have a greater risk of high-pressure or vapor lock and is not safe.
- The Pressure reducer is an important component of the gas supply system. You should pay particular attention to its operation. If leakage occurs, the unit should be replaced. Periodically remove the pollution discharge plug on the pressure reducer. Drain off the oil and condensation. If the obstruction is not drained off, it can seriously affect its performance.

2. When using NG as fuel:

- Before each operation, you should check the integrity of the various components and handle any loose fasteners immediately! Check if there's any leakage from the fuel lines, pipes and connections (soapy water can be used). Take care of leakage ASAP!
- Periodically check the pressure reducer, if the solenoid valve sealing pad is deformed, replace.
- Periodically check to see if any visible signs of wear, aging or leak detection are observed, repair or replace. Soapy water can be used to detect leaks around connections.
- During maintenance of the gas line, the valve must be closed prior to repair.
- When the engine is operating, especially at high load, it should run 1-3 min in no load state, to allow the engine to cool. Do not touch hot engine or electrical parts. The engine and exhaust system components become extremely hot during operation. Make sure unit is disconnected from main power and main gas lines before converting.

components become extremely hot during operation. Make sure unit is disconnected from main power and main gas lines before converting

Two fuel connections on the fuel block allow field conversion between natural gas (NG) and Liquid Propane (LPG). The fuel metering valves are factory-set and sealed to provide the best possible hot and cold starting.

Use the following procedure to convert fuel from one type to another.
Natural Gas (NG) and Liquid Propane (LPG) Conversion

- Use a pressure reducing valve to reduce LPG pressure supply.
- Pushing the button as attached pictures show below to the natural gas or LP vapor per the fuel which you want to use. Push in for LPG and out for NG.



LPG = button in

Liquid propane (LP Vapor)

In engines set up to run on Liquid propane, please check the fuel supply pressure, lower or higher pressure range will result in equipment failure. Inlet pressure 1.7kPa to 3.5kPa, and gas line should be no longer than 16 feet or 5 meters, the inner diameter shall not be less than (0.63") or 16mm.

NG = button out



Pressure Relief Valve

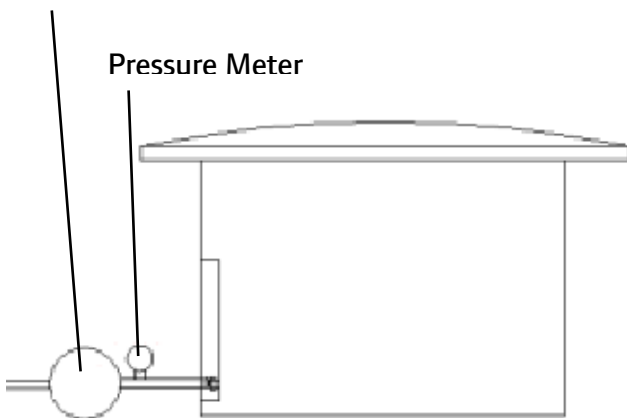

INSTALLING & CONNECTING GAS LINES

1. Natural gas and LP Vapors are highly explosive substances; you must follow all safety, codes, standards and regulations. Use a certified plumber or licensed contractor familiar with local codes to make all gas line connections. Always use AGA-approved gas pipe and a quality pipe sealant or joint compound. Verify the capacity of the natural gas meter or the LP tank in regards to providing sufficient fuel for both the generator and other operating appliances.
2. Most all applications will require an external manual shutoff valve on the fuel line.
3. Only use UL Listed or AGA-approved flexible fuel line in accordance with local regulations, when connecting the gas line to the generator. The section of flexible fuel line is to ensure that vibration from the generator does not create a gas leak at a connection point. Because of this, it's important the fuel line be installed with as few connection points and bends as possible.
4. Do not bend flexible fuel line to avoid using an elbow. Bending the flexible fuel line decreases its ability to absorb vibrations and defeats the purpose. It also prevents smooth fuel flow.
5. After checking for leaks, check the gas pressure at the REGULATOR to make sure there's enough gas pressure for generator operation. See Owner's Manual for fuel pressure specifications. If not within these limits, contact your local gas supplier.
6. After checking and testing gas pressure regulator, close the main shutoff valve.



LP Regulator

EXTERNAL POWER CONNECTIONS & WIRING DIAGRAM

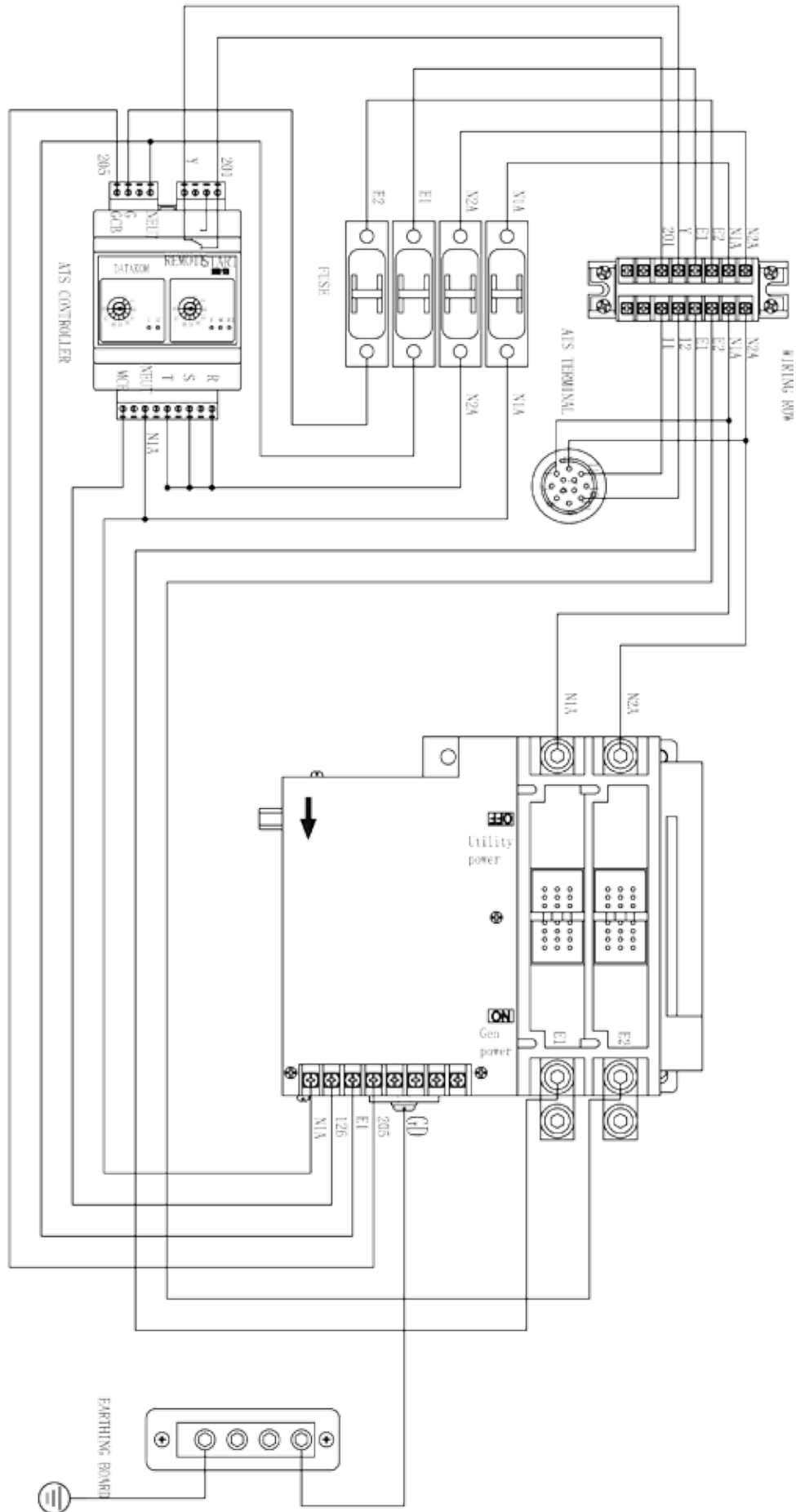

1. Locate area where electrical conduit will enter structure and drill 1.75" hole. Feed conduit through hole, sealing both exterior and interior with caulk.
2. Seal the hole with silicone caulk. Don't forget to caulk the hole inside the house as well.
3. Remove knockout in the back of connection box, feed wires through the back of the box and secure the conduit with lock nut.
4. Mount connection box over whole in structure. Seal around all sides with weather proof caulk.
5. Connect all wires to the lugs inside connection box. Connect, black to black, red to red, white to white. Connect ground wire to the ground lug and then connect breaker connections.
6. Close cover and lock connection box.

Initial battery connection and controller activation



1. When battery power is applied to the generator and the power switch is in the on position, the digital controller will light up. However, the generator controller still needs to be activated and programmed before it will automatically run in the event of a power outage.
2. Battery Connection - connect positive red lead wire first (+) and then negative lead black wire (-) to matching positive (+) and negative (-) terminals on battery. Connect negative (-) lead last!
3. Programming the generator is a one-time process that is guided by the controller screen prompts. Once the product is activated, the controller screen will not prompt you again, even if you disconnect generator battery. See SmartGen Owner's Manual for programming
4. An "Activation Password" is required to unlock the controller for basic programming (date/time/delay/exercise) and to enter into full feature parameter settings. Please contact (800)-###-#### with your Serial Number to receive activation password and register your liquid cooled system for warranty.
5. IMPORTANT! The generator will not start and circuit board damage can occur if battery is connected in reverse.

(Before initial use the maintenance free battery should be tested for voltage, if >12.6V, it can be installed and used immediately; After first time use or <12.6V it should be re-charge before use.)

When replacing battery, always use the same size battery and number type: 12V, Lead-acid battery.

CAUTION – Do not dispose of battery or batteries in a fire. Batteries are capable of exploding.

CAUTION – Do not open or mutilate the battery. Released electrolytes have been known to be harmful to skin, eyes and to be toxic.

CAUTION – A battery presents a risk of electrical shock and high short circuit current. The following precautions are to be observed when working on batteries:

1. Remove watches, rings, or other metal objects.
2. Use tools with insulated handles.
3. Wear rubber gloves, apron, eye protection and boots.
4. Do not lay tools or metal parts on top of batteries.
Make sure the generator set is grounded. Check grounding strap to make sure the generator set ground terminal is securely grounded to a grounding rod.

For first time use, you should operate according to these steps:

- Installing battery - take off red cap on positive battery terminal.
- Use a multi-meter to check voltage of battery before installing and starting. If reading is below 12.6V, recharge battery.
- Connect positive terminal lead. Tighten terminal lead nut on battery and place red rubber cover over terminal.
- Follow the same steps for negative or black battery lead, then place rubber cover over terminal.



The battery represents a risk of high short circuit current. When working on the battery, always remove watches, rings or other metal objects, and only use tools that have insulated handles!

Installing, Servicing or Exchanging the Battery should be performed or supervised by knowledgeable personnel. Battery connection or exchange requires precautions and protective gear. Always wear face and eye protection with electrical rubber gloves, boots and battery apron. Keep unauthorized personnel away from battery.

GENERATOR CONNECTION

If the switch was purchased separately from the generator, a Seal-Tite electrical whip will need to be connected to the generator. To complete the wiring, run $\frac{3}{4}$ " conduit for the power leads and control wires from the external connection box to the generator.











1. Feed the wires through the back of the generator and secure the conduit with lock nut.
2. Run power leads through the strain relief hole provided.
3. The circuit breaker and control panel are located under the top lid. Unlock and lift open to gain access.



4. Remove the screws on the control panel cover to gain access to the connection area.
5. Feed the wires through the back of the generator and secure the conduit with locking nut.
6. Run power leads through the strain relief provided.
7. The circuit breaker is mounted inside next to the generator digital controller.
8. Secure circuit connections
9. Users must connect the GND wire to the grounding lug and tighten.
10. The GND wire should be the same size but not smaller than the load wire.
11. Connect according to the following connector bar from left side to right side.
12. Connect according to the following type due to different Models.

Use insulated and certified wire/cable hose to connect the output hole. And the AC output wires/cable, and ATS control wires shall be separated by an insulation bushing (min 1.0mm). Tighten all wires before operating generator set, or it will cause short circuit failure, do not connect generator sets together, damage may occur if wires are connected in reverse. The AC output wires shall be at least 3AWG, and temperature rating shall not less than 75°C, and copper wire.

Operation

	Stop/ Reset	Stop running generator in Auto/Manual mode; Lamp test (press at least 3 seconds); Reset alarm if alarm occurs; During stopping process, press this button again to stop generator immediately.
	Start	Start genset in Manual/Test mode.
	Manual Mode	Pressing this key will set the module into Manual mode. Pressing  and  (or ) simultaneously can adjust LCD contrast.
	Auto Mode	Pressing this key will set the module into AUTO mode.
	Set/Confirm	Pressing this key will view set menu; In parameter setting interface, pressing this key will shift cursor or confirm setting value.
	Up/Increase	Scrolls the screen up; Shift the cursor up or increase the set value in parameter setting menu.
	Down/Decrease	Scrolls the screen down; Shift the cursor down or decrease the set value in parameter setting menu.

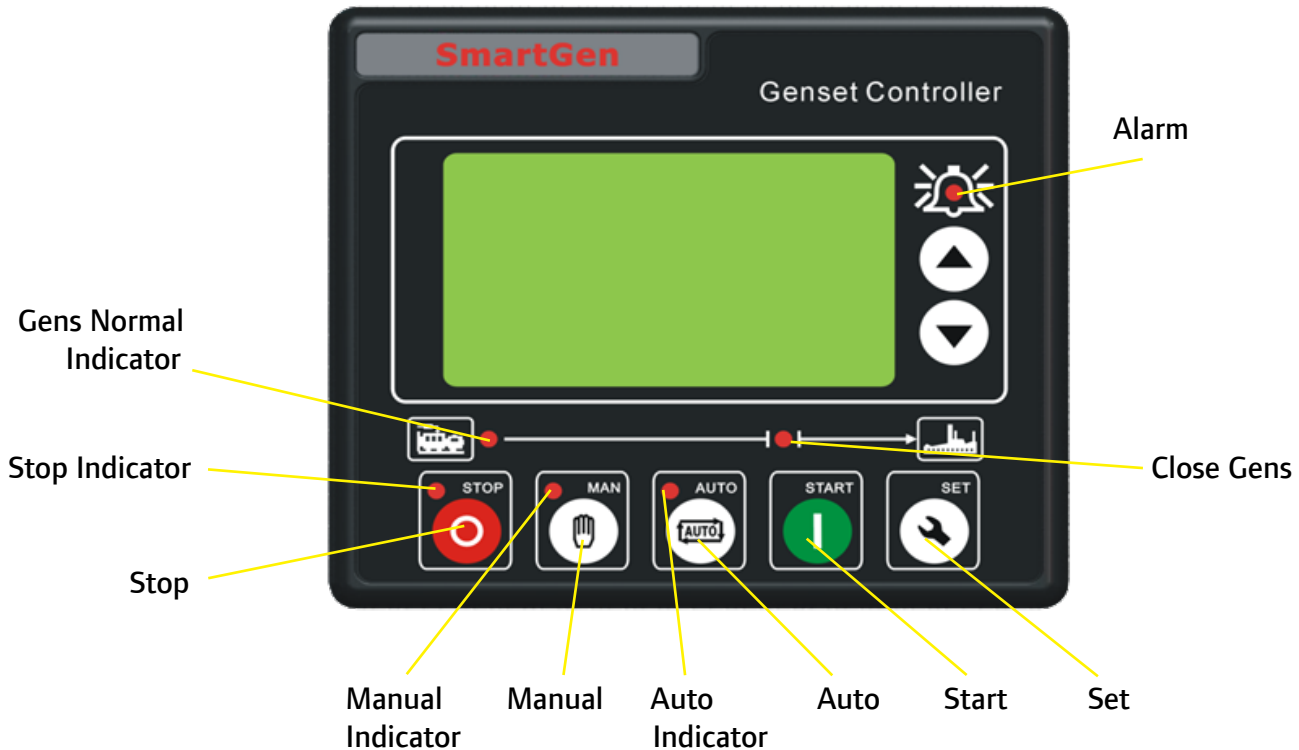

INDICATOR LIGHTS



AUTO START/STOP OPERATION

Auto mode is selected by pressing the  button; a LED beside the button will illuminate to confirm the operation.

Manual Start Sequence:

1. MANUAL START: Manual mode is selected by pressing the  button; a LED beside the button will illuminate to confirm the operation; then press  button to start the genset; it will detect crank disconnect condition and generator accelerates to high-speed running automatically. With high temperature, low oil pressure, over speed and abnormal voltage during generator operation, controller will protect genset and stop quickly. (please refer to No.3~8 of Automatic Start Sequence in controller manual for detailed procedures.) The controller will send Close Gen signal after the genset is running normally.
2. MANUAL STOP: Press  to stop the running generator. (please refer to No.2~6 of Automatic Stop Sequence for detailed procedures).

Automatic Start Sequence:

1. When "Remote Start" is active, "Start Delay" timer is initiated;
2. "Start Delay" countdown will be displayed on LCD;
3. When start delay is over, preheat relay energizes (if configured), "preheat delay XX s" information will be displayed on LCD;
4. After the above delay, the Fuel Relay is energized, and then one second later, the throttle of the driving stepper motor will rotate as the pre-set angle and then the Start Relay is engaged. The engine is cranked for a pre-set time. If the engine fails to fire during this cranking attempt then the fuel relay and start relay are disengaged for the pre-set rest period; "crank rest time" begins and wait for the next crank attempt.
5. Should this start sequence continue beyond the set number of attempts, the start sequence will be terminated, the fourth line of LCD display will be highlighted with black and Fail to Start fault will be displayed.
6. In case of successful crank attempt, the "Safety On" timer is activated and the throttle of the driving stepper motor will govern the speed, allowing Low Oil Pressure, High Temperature, Under speed, Charge Alternator Failure and auxiliary inputs (be configured) to stabilise without triggering the fault. As soon as this delay is over, "start idle" delay is initiated (if configured).
7. During "start idle" delay, under speed, under frequency, under voltage alarms are inhibited. When this delay is over, "warming up" delay is initiated (if configured).
8. After the "warming up" delay, if generator status is normal, its indicator will be illuminated. If generator voltage and frequency have reached on-load requirements, then the generator close relay will be energized; genset will take load; generator power indicator will illuminate and generator will enter into Normal Running status. If voltage or frequency is abnormal, the controller will initiate shutdown alarm (alarm information will be displayed on LCD).

Automatic Stop Sequence:

1. When the "Remote Start" signal is removed, the Stop Delay is initiated.
2. Once this "stop delay" has expired, the Generator Breaker will open and the "Cooling Delay" is then initiated. Moreover, the generator indicator is extinguished.
3. During "Stop Idle" Delay (if configured), idle relay is energized.
4. "ETS Solenoid Hold" delay begins, ETS relay is energized while fuel relay is de-energized.
5. "Fail to Stop Delay" begins, complete stop is detected automatically.
6. When generator is stop completely, generator is placed into its standby mode. Otherwise, fail

- to stop alarm is initiated and the corresponding alarm information is displayed on LCD.
7. Now connect the red and black power leads to the circuit breaker. Since this is a single-phase application, it does not matter which wire is connected to which lug.
 8. Connect the green equipment ground wire to the ground bus bar and torque to 35 inch lbs. The torque values are:
 - 10-14 AWG = 35 in/lbs.
 - 8 AWG = 40 in/lbs.
 - 4-6 AWG = 45 in/lbs.
 9. Connect the white neutral wire to the neutral bus bar and torque to 35 inch lbs. The torque values are:
 - 10-14 AWG = 35 in/lbs.
 - 8 AWG = 40 in/lbs.
 - 4-6 AWG = 45 in/lbs.
 10. **IMPORTANT NOTE:** Connect the control wires to the correct terminals. In order to maintain separation of circuits, the DC control wires must be separated from the AC control wires. Wrap insulation over the AC wires OR the DC wires, but not both, from the wire landing area to the outside of the generator. Use cable lock to hold the insulation in place. **An improperly connected control wire can damage the generator control board.**

Parameter Settings

Make sure power is on before starting the controller, then press  to enter into the parameters setting menu, see fig 1 below:

Fig. 1



Parameters Setting

When entering password interface, input correct password (default: 1234) can set all of the parameter items in Form 1. If there is need to set more parameters (e.g. Voltage Calibration), please contact the factory.

⚠ CAUTION: Please change the controller parameters when generator is in standby mode only (e. g. Crank disconnect conditions selection, auxiliary input, auxiliary output, various delay), otherwise, shutdown and other abnormal conditions may happen.

⚠ CAUTION: Over voltage set value must be higher than under voltage set value, otherwise over voltage and under voltage condition may occur simultaneously.

⚠ CAUTION: Over speed set value must be higher than under speed set value, otherwise over speed and under speed condition may occur simultaneously.

⚠ CAUTION: Please set the generator frequency value as low as possible when cranking, in order to make the starter is separated quickly as soon as possible.

CAUTION: Auxiliary input 1~5 could not be set as same items; otherwise, there are abnormal functions. However, the auxiliary output 1~4 can be set as same items.

CAUTION: If need to shut down after cooling, please set any digital input as “WTH STOP by cool”, then connect this input port to ground soundly.

Information

LCD will display software version, issue date of the controller.

Note: In this interface, pressing  will display the auxiliary inputs and outputs status.

Language

Chinese, English, Spanish and Russian interface can be selected.

Time and Date

The time and date information can be set in this interface.

Pressing the  key at any time will quit the setting and return to the previous settings menu.

Typical Application

Typical Application Diagram

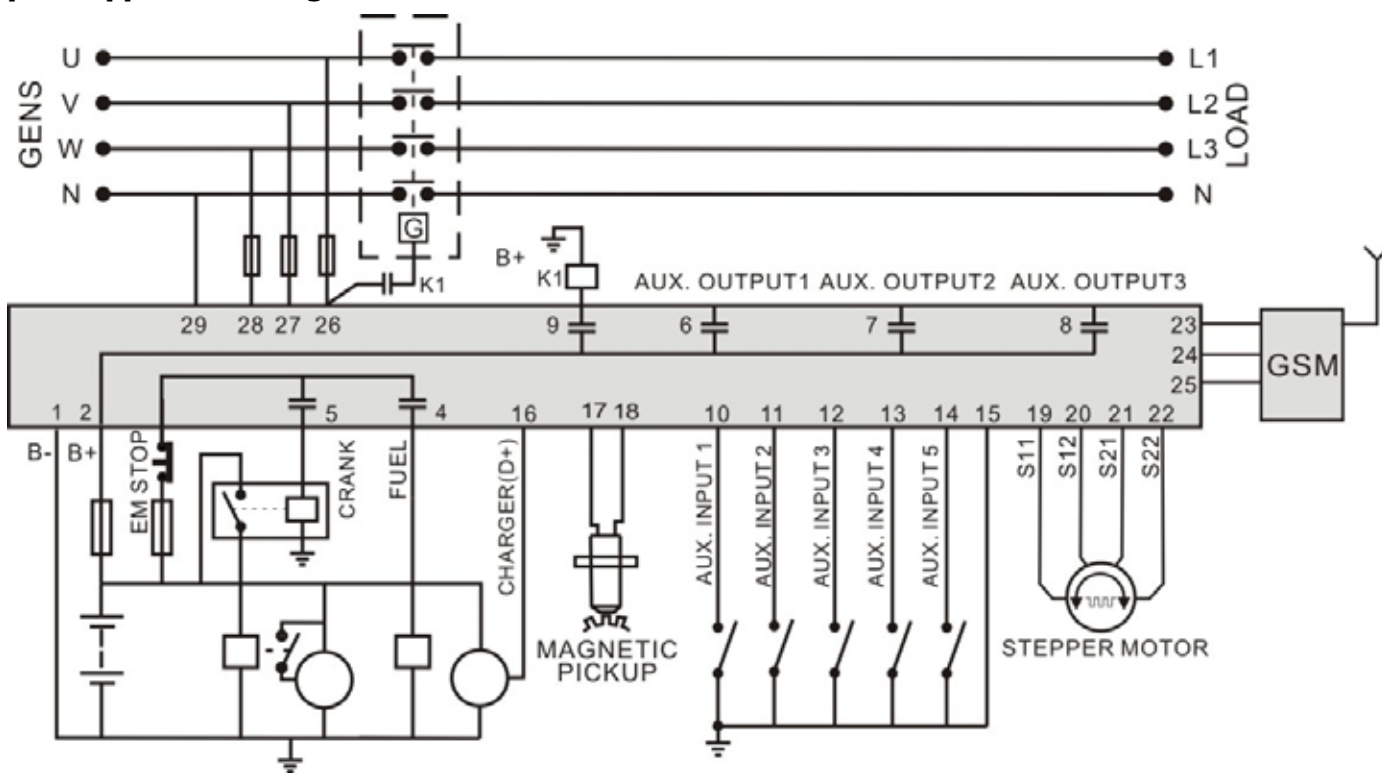

CAUTION! Expand relay with high capacity in start and fuel output is recommend.

CAUTION! Expand relay must be used in generator closed outputs.

Connection Between Controller And Genset

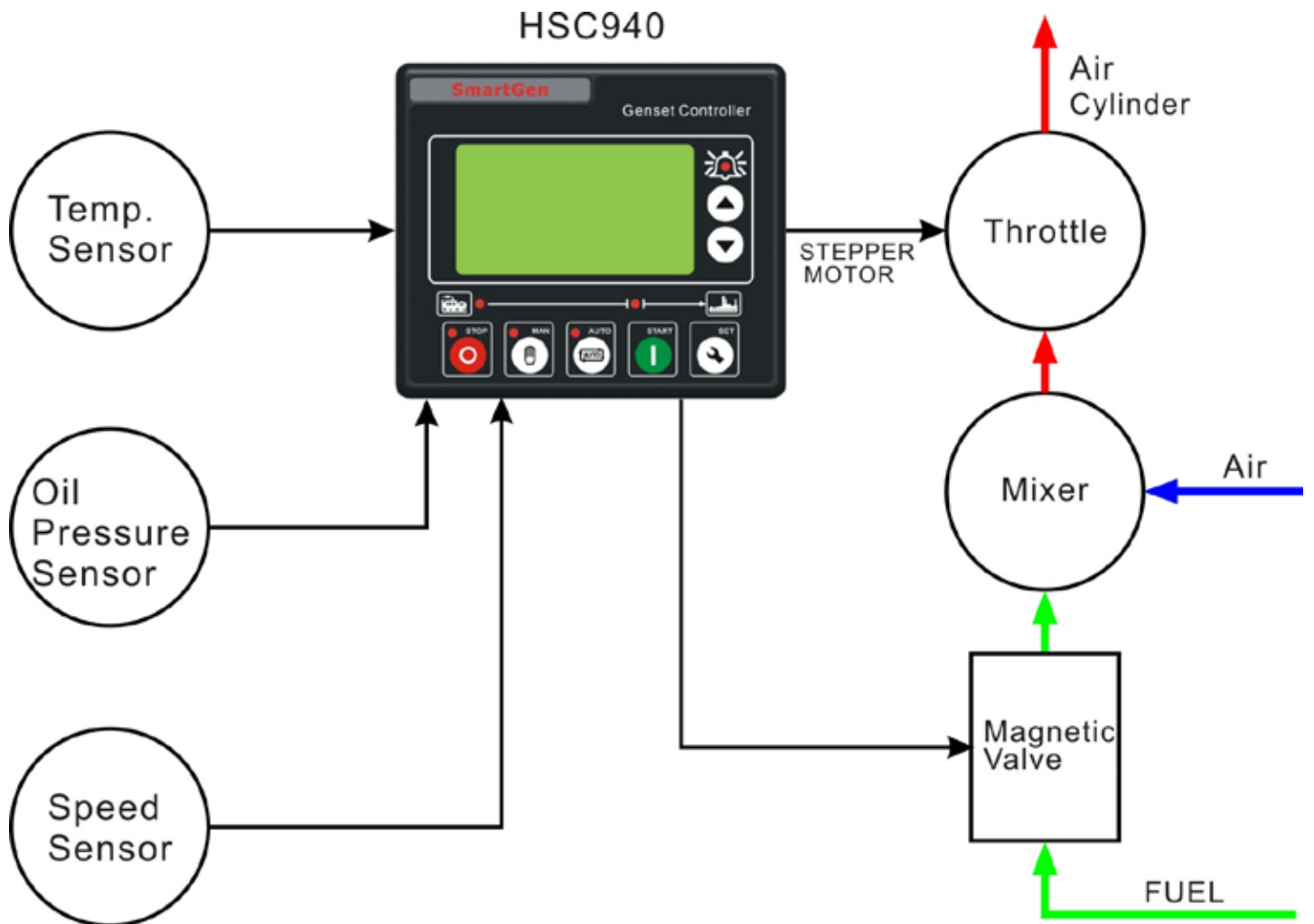

Controller Specifications

Items	Contents
Operating Voltage	DC8.0V to DC35.0V, Continuous Power Supply.
Power Consumption	Standby: $\leq 2W$ Working: $< 8W$ (When driving stepper motor is regulating)
Alternator Input Range 3-Phase 4-Wire 2-Phase 3-Wire Single-Phase 2-Wire 3-Phase 3-Wire	AC15V - AC360V (ph-N) AC15V - AC360V (ph-N) AC15V - AC360V (ph-N) AC30V - AC620V (ph-ph)
Alternator Frequency	50Hz/60Hz
Speed Sensor Voltage	1.0V to 24.0V (RMS)
Speed Sensor Frequency	10,000 Hz (max.)
Start Relay Output	5A DC28V supply output
Fuel Relay Output	5A DC28V supply output
Auxiliary Relay Output (1)	5A DC28V supply output
Auxiliary Relay Output (2)	5A DC28V supply output
Auxiliary Relay Output (3)	5A DC28V supply output
Auxiliary Relay Output (4)	5A DC28V supply output
Steady-state Speed Governing Rate	$< 1.5\%$
Steady-state Speed Fluctuation Rate	$< 0.5\%$
Transient Speed Governing Rate	Sudden Load-on $< +10\%$ Sudden Load-off $> -15\%$
Recovery Time	$< 5s$
Driving Stepper Motor	Mixed 2-phase; Drive current $\leq 1A$
Case Dimension	5.12"x 4.4"x 1.5" / (130mm x 112mm x 39mm)
Panel Cutout	4.35" x 3.5" / (110mm x 90mm)
Working Conditions	Temperature Range: $-13\sim+158^{\circ}F$ / $(-25\sim+70)^{\circ}C$ Humidity: (20~93)%RH
Storage Condition	Temperature: $-13\sim+158^{\circ}F$ / $(-25\sim+70)^{\circ}C$
Protection Level	IP55 Gasket
Insulating Intensity	Apply AC2.2kV voltage between high voltage terminal and low voltage terminal; Test current leakage for not more than 3mA within 1min.
Net Weight	0.57 lbs. (0.26kg)

Wiring Connections



Description of terminal connection: For more complete information refer to the Controller Owner's Manual.

No.	Function	Cable Size	Remarks
1	B-	2.5mm ²	Connected with negative of starter battery
2	B+	2.5mm ²	Connected with positive of starter battery. Max. 20A fuse is recommended.
3	EM. Stop	1.5mm ²	Connected with B+ via emergency stop button
4	Fuel	1.0mm ²	Fuel relay output; B+ is supplied by 3 terminal; rated 5A
5	Crank	1.0mm ²	Start relay output; B+ is supplied by 3 terminal; rated 5A; Connected to starter coil.
6	Aux. Output 1	1.0mm ²	B+ is supplied by 2 terminal; rated 5A
7	Aux. Output 2	1.0mm ²	B+ is supplied by 2 terminal; rated 5A;
8	Aux. Output 3	1.0mm ²	B+ is supplied by 2 terminal; rated 5A;
9	Aux. Output 4	1.0mm ²	B+ is supplied by 2 terminal; rated 5A;

Wiring Connections

Continued:

No.	Function	Cable Size	Remarks
10	Aux. Input 1	1.0mm ²	Ground connected is active (B-)
11	Aux. Input 2	1.0mm ²	Ground connected is active (B-)
12	Aux. Input 3	1.0mm ²	Ground connected is active (B-)
13	Aux. Input 4	1.0mm ²	Ground connected is active (B-)
14	Aux. Input 5	1.0mm ²	Ground connected is active (B-)
15	GND	The common port of sensor; (B-) has already connected.	
16	CHARGER (D+)	1.0mm ²	Connected with charger starter's D+ (WL) terminals.
17	MP2	1.0mm ²	(B-) has already connected. Connected with Speed sensor, shielding line is recommended.
18	MP1	1.0mm ²	Connected with Speed sensor, shielding line is recommended.
19	S11	1.0mm ²	Connect to stepper motor. S11 and S12 are belong to one phase to the motor while S21 and S22 are belong to the other phase.
20	S12	1.0mm ²	
21	S21	1.0mm ²	
22	S22	1.0mm ²	
23	RS232 RX	0.5mm	Connected to GSM module.
24	RS232 TX	0.5mm	
25	RS232 GND	0.5mm	
26	Gens AC Voltage (U)	1.0mm ²	Connected to U-phase of generator (2A fuse is recommended).
27	Gens AC Voltage (V)	1.0mm ²	Connected to V-phase of generator (2A fuse is recommended).
28	Gens AC Voltage (W)	1.0mm ²	Connected to W-phase of generator (2A fuse is recommended).
29	Gens AC Voltage (N)	1.0mm ²	Connected to N-phase of generator (2A fuse is recommended).



NOTE: LINK interface is parameters configured interface that can be programmed by PC using an SG72 adapter. If there is need to remotely monitor the genset, please use the SG361 module produced by SmartGen.

Automatic Transfer Switch (ATS) Installation

- **Before beginning any installation, make sure power is shut OFF** to the main distribution panel and carefully read the ATS Owner's Manual that came with the system.
- All wiring must be the correct size and type, and must conform to all codes, standards and regulations. Refer to the Transfer Switch Owner's Manual and the National Electrical Code for additional information
- The distribution load center switch in the ATS must be mounted close enough to the main distribution panel to accommodate electrical conduit and the included 12 ft. EZ connection wiring harness from ATS to standby unit. Make sure no water or corrosive substances can drip onto the transfer switch enclosure. Additional longer wiring harness lengths (20, 50 and 80 feet) are available from your dealer.
- Always inspect the switch for shipping damage. Never install a transfer switch that shows any sign of damage. Protect against impact and mount the switch vertically to a rigid support structure. Make sure the switch is level and plumb.
- The automatic transfer switch is an open transition switch. Open transition switches prevent electrical feedback between the generator and the utility by only allowing load circuits to be connected to one power supply at a time.
- When three-conductor wiring is used, two 120 volt circuits will often share the same neutral wire. To avoid overloading the neutral, either move BOTH of the circuits that share the neutral or don't move either of them.
- When moving two circuits with a shared neutral, they should be connected to adjacent positions (one above the other) in the transfer switch. That will assure that the two hot wires are on separate phases and will maintain their relationship to neutral.
- Choose a circuit to be backed up and remove the power lead from the breaker.
- Using UL Listed wire nuts, reconnect the power lead to a matching breaker in the transfer switch.
- Make sure each circuit moved is protected by the same size breaker in the transfer switch. 15 Amp circuits must be connected to 15 Amp breakers and 20 Amp circuits to 20 Amp breakers.
- Connect large neutral to the neutral bar in the distribution panel.
- Install a 2-pole breaker in the distribution panel to protect the transfer switch. The required amp rating of the breaker depends on which transfer switch is used. The ATS included with this unit is 200 Amps. This breaker must be compatible with the existing electrical distribution panel.
- Install the breaker in two adjacent empty slots (one above the other) in the main panel.
- EZ connect wiring harness, from ATS to generator control panel. Locate control panel wiring harness prewired inside ATS. The 12 foot long controller harness passes through the electrical access ports on the corner of generator above gas line connection.
- EZ Pre-Wired Controller harness w/female plug is located inside the ATS.



**Generator Electrical Access Port
Easy Controller receptacle on
Generator**

Controller wiring harness inside ATS
with Easy Connection

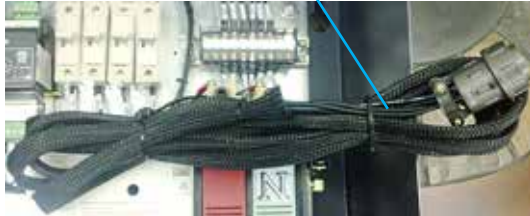

Wires / cables hose

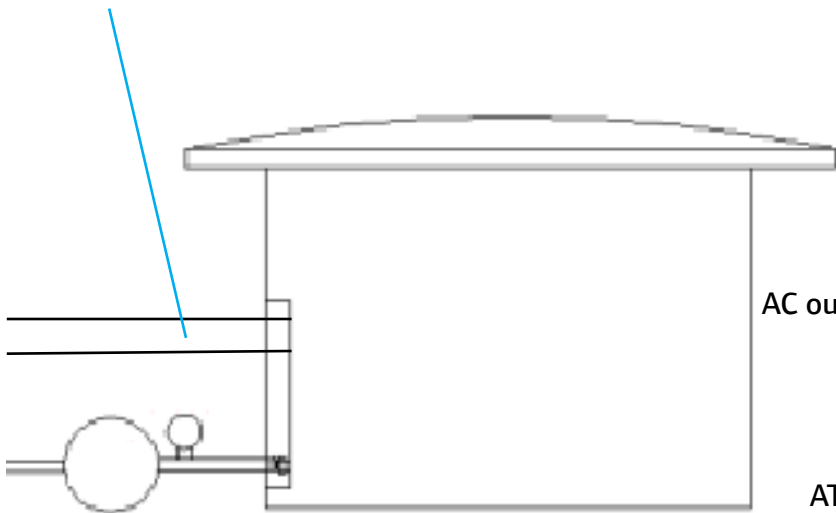

AC output terminal

ATS connection



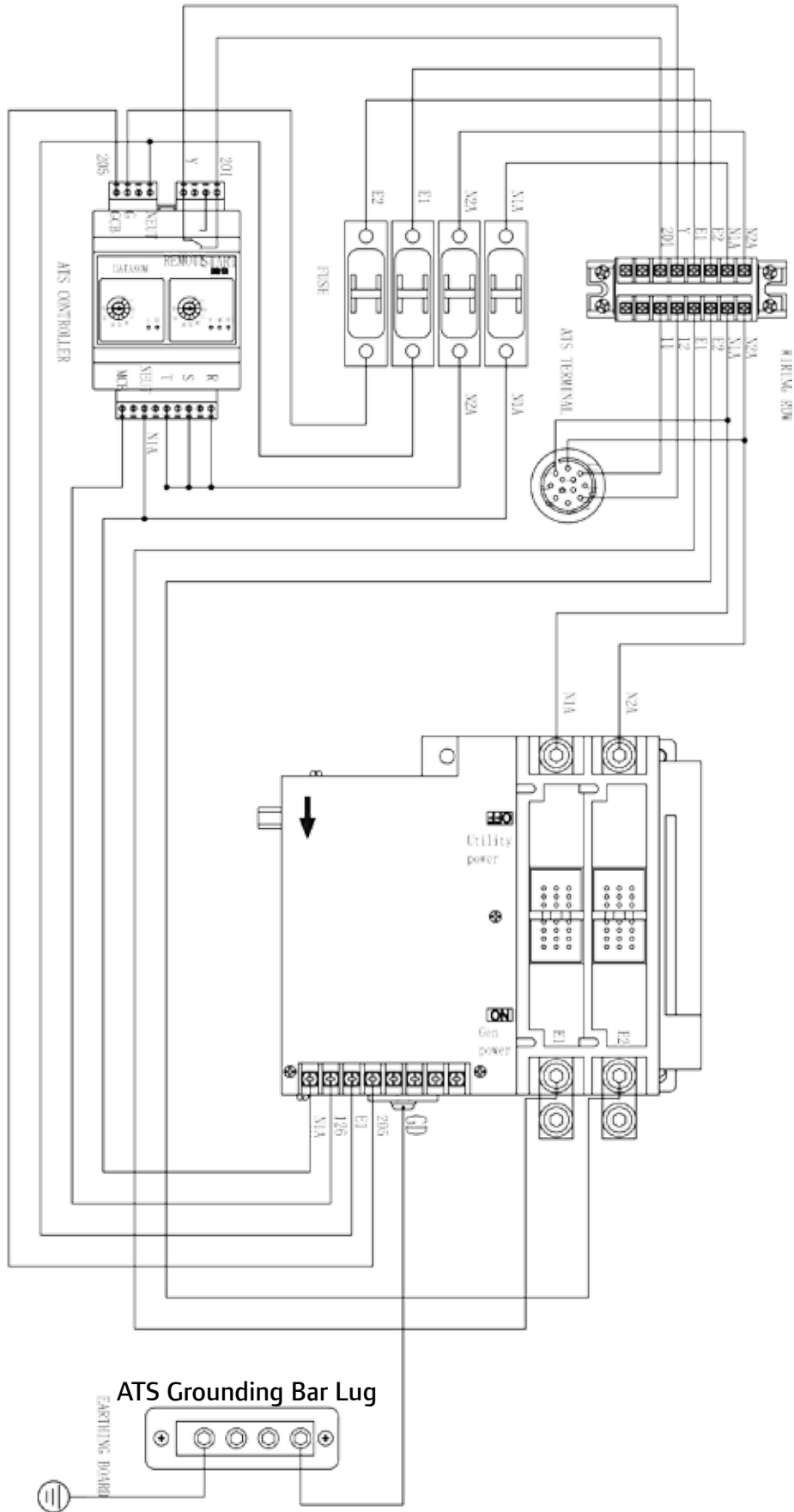

- The connection receptacle is located on the back side of control panel inside the standby generator. Remove rear panel to view the connection, from ATS. The wire will go out through the wire outlet on the enclosure., passing harness through wire access in standby
- When all priority circuits have been moved to the transfer switch, close the main breaker to restore utility power and make sure utility voltage at the transfer switch is correct. Refer to NFPA 70-E for safety equipment required when working inside a live transfer switch.

ATS Wiring Diagram



Testing

1. Switch the generator's main circuit breaker, located on control panel in the OFF position and also put the ATS switch in the OFF position.
2. Make sure utility power is OFF and place all of the priority circuit breakers in the transfer switch in the OFF position as well.
3. Locate the transfer of power switch inside the ATS; use included handle to move the main contacts to the standby power, or generator position.
4. NEVER OPERATE THE TRANSFER SWITCH MANUALLY WHEN LOADS ARE CONNECTED!
5. Start engine by turning fuel and power switches in ON position. Allow fuel to flow for 15 to 20 seconds. Test and smell for gas leaks. Press  "MAN" button first then press start button .
6. Allow the engine to warm up, and then switch the generator's main breaker to the ON position. The generator is now supplying electricity to the transfer switch but is not carrying any load.
7. Be sure that voltage and frequency from the generator is correct. If line-to-line voltage is not approximately 120/240 volts, refer to the Owner's Manual for the proper adjustments needed.
8. On all models, if line-to-neutral voltage is not 120 volts, check the neutral connection between the generator and transfer switch.
9. When finished checking voltage, switch the generator's main circuit breaker OFF and push the OFF button  to shut down the generator.
10. Make sure the 2-pole circuit breaker installed in the main distribution panel is in the OFF position.
11. Use the transfer handle to move the main contacts in the transfer switch to (utility position). Switch the 2-pole breaker ON in the distribution panel.
12. Now switch the generator's main breaker ON, and put the mode switch on AUTO.
13. Shut OFF utility power and make sure the generator starts automatically.
14. If everything works correctly, switch the main breaker to ON position and make sure that power is automatically transferred back to the utility and standby power shuts down automatically.
15. After engine has completed its cool down cycle and shut down, shut OFF utility power again.
16. When the generator is supplying power to the transfer switch, move the breakers in the switch to the ON position, one at a time, until the generator has accepted the entire selected load.

IMPORTANT

17. With the generator carrying the entire priority load, recheck gas pressure to verify that it is at the same level it was before the generator was started.
18. Even if the generator is running smoothly at this point, a drop-in gas pressure indicates that the supply is barely adequate to supply the generator's needs. Changes in the generator load, or additional gas demand by other appliances may affect the generator's overall performance. Verify gas pressure and pipe size.
19. Switch the main breaker ON to restore utility power.
20. The generator will continue to run to allow the engine to cool down before shutting down.
21. Close the main breaker to restore utility power and allow the engine to cool its self down and shut off automatically.
22. Operational tests are now complete. Refer to – Setting the Automatic Exercise Function to complete the installation.
23. Testing is now complete.
24. Refer to SmartGen Controller Manual: Setting Automatic Exercise Function to complete installation.

Testing

CIRCUIT COVERAGE FOR WHOLE HOUSE AND SMALL COMMERCIAL

1. If the generator will be backing up all electrical loads within the panel, the amperage rating of the transfer switch must be equal to or greater than the amperage rating of the normal utility service. Unless a service rated transfer switch is used, a main service disconnect must be located before the transfer switch. The transfer switch must be installed between the utility service entrance and the building distribution panel.
2. A service rated transfer switch is installed between the service and the main distribution panel. The service rated switch becomes the main service so no service disconnect is needed. The existing main distribution panel becomes a sub-panel.
3. The grounding that is normally in the main panel must be accomplished in the service rated switch and must be disconnected in the existing distribution panel. Refer to the National Electrical Code (NEC) for complete information on grounding and bonding.

SPECIFIED ELECTRICAL CIRCUIT COVERAGE

IMPORTANT

If the generator only powers designated breakers and circuits that are already grouped together and wired into a separate specified distribution panel, the ATS must be installed between the main electrical panel and specified distribution panel. The amperage rating of the transfer switch must be equal to or greater than the highest amperage rating of the utility and generator breakers feeding the switch.

ELECTRICAL CONNECTIONS

Secure circuit connections:

- Users must connect the GND wire to the grounding lug and tighten.
- The GND wire should be the same gauge as than the load wire.
- Connect according to the following connector bar from left side to right side.
- Connect according to the following type due to different Models.

Use the insulated and certified wire/cable hose to connect the output hose and the AC output wires/cable, and ATS control wires shall be separated by an insulation bushing (min 1.0mm) Tighten all wires before operating generator set, or it will cause short circuit failure, do not connect generator sets together, damage may occur if wires are connected in reverse. The AC output wires shall be at least 3AWG, and temperature rating not less than 75°, and copper wires.

- a. Connect the power leads from both the generator and the utility to the appropriate lugs in the transfer switch. The lugs are clearly marked in the switch.

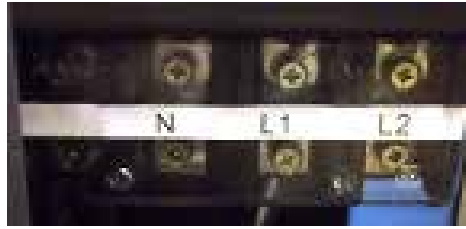

- b. Neutral wires from both the utility and the generator are connected to the same neutral bar in the switch.



ATS Grounding Bar Lug



Generator Grounding Bar Lug

- c. Connect the control wires from the generator to the designated locations.
- d. Complete the transfer switch wiring by connecting the equipment ground wires from both the utility and the generator to the grounding bar lug.
- e. **Being careful to support the lugs, torque lugs to 20 N.m inside the transfer switch.**

FUNCTIONAL TESTING OF UNIT

1. Switch the main utility breaker OFF. Refer to NFPA 70-E for the safety equipment required when working inside a live transfer switch.
2. Engage the utility power and check line-to-line and line-to-neutral voltage at terminals on the transfer contactor. If line-to-line voltage is not approximately 240 volts, disengage utility power and check terminal between the utility and Neutral 1 and Neutral 2. If line to neutral is not reading approx. 120 volts, shut down utility power and re-inspect neutral terminal connections.
3. Repeat the same voltage checks on terminals to make sure current is flowing properly through the contactor.
4. Switch the generator's main circuit breaker OFF and put the mode switch in the OFF position.
5. Make sure utility power is in the OFF position and place all individual circuits in the main power panel in off position as well.



6. Locate the transfer handle; insert the metal end into the slot in the main contactor assembly. Pull the handle DOWN to move the main contacts to the standby power (generator) position. NEVER OPERATE THE TRANSFER SWITCH MANUALLY WHEN LOADS ARE CONNECTED.



ATS



Transfer
Handle



Transfer Lug

7. Locate the transfer handle; insert the metal end into the slot in the main contactor assembly. Pull the handle DOWN to move the main contacts to the standby power (generator) position. NEVER OPERATE THE TRANSFER SWITCH MANUALLY WHEN LOADS ARE CONNECTED.
8. Place generator in MANUAL mode before initiating start. After warmup, transfer the generator's main breaker in the ON position. At this point, the system is now supplying electrical power to the ATS but is not applying any electrical load
9. Check to be sure that voltage and frequency from the generator is correct. If voltage to the line is not at least 240 volts, reference TR20REG-DB Owner's Manual for proper corrective procedures. If line-to-neutral voltage is not approximately 120 volts, check the neutral connection between the ATS and generator.
10. Transfer the generator's main circuit breaker to OFF position and put the mode switch in the OFF position to shut down the generator.
11. With utility power still OFF, use the switch handle to move the main contacts to the Utility power ON position.
12. Transfer the main breaker to turn utility power ON.
13. Transfer generator's main breaker to ON position and set the ATS switch in AUTO mode.
14. To test, SHUT OFF utility power. Generator should start automatically after the time set delay has expired.

15. Switch the utility breaker to ON and make sure that power is automatically transferred back to the utility, shutting down generator automatically after cool down period.
16. Turn OFF utility power once again to automatically start the generator. When power has transferred to the generator, in the distribution panel, turn each of the breakers to ON position one at a time until generator is accepting the full load.
17. With generator on full load, check and recheck gas pressure to verify that it's maintaining the same pressure level, prior to starting generator.
18. **CAUTION!** Even though generator sounds and runs smoothly, changes in the electrical loads or additional gas demand by other appliances will affect the generator's performance. Verify gas pressure and pipe sizing. Turn off the gas, unhook the manometer and reinstall port plug.
19. Transfer utility breaker to ON position to restore electrical utility power.
20. The generator will continue to run to allow the engine to cool down, then it will shut down automatically.
21. Shut OFF utility power again. The generator should start and the entire electrical load will transfer to the generator.
22. Close the main breaker to restore utility power and allow the engine to cool down and shut itself off.
23. Operational tests are now complete. Refer to SmartGen Owner's Manual for setting the Automatic Exercise Functions. This will complete the installation.

Maintenance of Genset

Regular maintenance is an integral part of the genset. To maintain good reliable condition, please maintain according to specifications.

The following genset maintenance specifications are based on a good working environment and normal operating conditions. Please strictly adhere to the following requirements. If working conditions are less than favorable, (such as excessive dust, humidity, excess ambient temperature or the temperature is too low, etc.) the maintenance period should be shortened accordingly.

Break-in of New Engine

The life of the engine is greatly dependent on the first 30 hours of use. It is vital to change the engine oil after this initial period of time. It is also an excellent time to inspect for leaks, loose belts, fluid levels, gas lines, and connections. Tighten if necessary.

Replacing engine oil

Start the engine for several minutes to increase the temperature of the engine oil and then stop engine.

- Remove front Generator panel
- Place oil pan out in front of the generator.
- Lower Oil Drain hose and loosen oil drain plug using 10mm allan wrench.
- Inspect oil drain screw and gasket for damaged. Replace if necessary.
- Tighten oil drain screw and gasket. Inspect for oil leakage!
- Fill with new engine oil and run engine for 2min. Shut down and recheck oil level.
- Add if needed. Oil level should be between level A (low) and B (full).

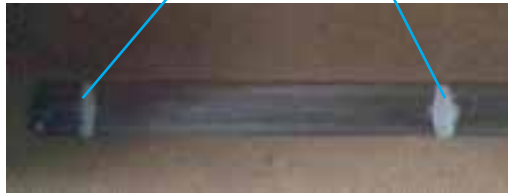

OIL FILTER REPLACEMENT

The oil filter must be replaced when the engine is cooled. The replacement cycle should be according to the maintenance cycle. Steps for replacement:

Use the included oil filter spanner/wrench to remove old oil filter.

- Coat oil filter gasket surface with a thin layer of oil to seat the new oil filter.
- Tighten the new oil filter.
- Manually run the genset for 3 minutes then shutdown. Check to see if there are any oil leaks. Then check the oil level of the oil pan and fill oil to the specified oil level.
- Use oil filter spanner to fix the oil filter, the torque is between 15N.M-20N.M. When you remove the filter cartridge, the oil level will drop. Be sure to check for oil spills.

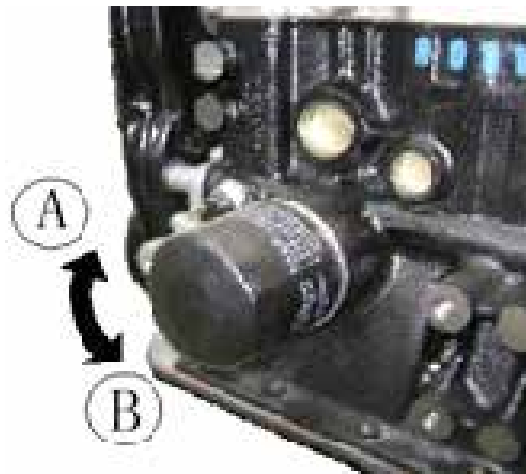

Direction A: Tighten

Direction B: Loosen

COOLING SYSTEM MAINTENANCE

When the engine is in operation, there must be enough coolant in the radiator system to allow for proper circulation. It is important to check this level regularly! Only use clean distilled water and high quality antifreeze. See Owner's Manual for more info and approved coolants.



Do not replace cooling liquid when the engine is hot!!!!!!

Check coolant effectiveness by using coolant tester during annual inspection of system. If needed, change coolant.

CHANGING COOLANT

- Remove front cover panel.
- Locate pre-plumbed coolant line with drain plug. Open drain plug with included 10mm Alan wrench and allow coolant to drain.
- Close drain plug securely.
- Refill with approved coolant and distilled water.
- Start genset without load for 1 minute. Allow air pockets to dissipate. Stop generator.
- Add cooling liquid to the radiator full level.
- Fill the expansion tank with coolant to the "FULL" level.
- Install the radiator cap and expansion tank cover. Inspect thoroughly for leaks!



**Hard water, saline water or mineral water is harmful to the engine.
Only use distilled water.
If not available, boil water and allow cooling before adding to radiator.**

WATER PUMP BELT ADJUSTMENT & REPLACEMENT

The Water pump belt is used to cool the engine. If the tension is too loose or too tight, it will cause engine overheating. If you hear the belt slipping or squealing, you should check the following. Adjust or Replace.

Belt deflection test:

7-10mm(0.28-0.35in/100N{10.01kgf(22.1 lbs)})

Adjust deflected belt:

- Stop the engine.
- Use the thumb to press on the belt of the pulley wheel.
- If the tightness is not correct, adjust it by relaxing the regulating wheel, until to the acceptable degree.
- Replace the water pump belt when it's cracked, missing sections of the belt, or broken.

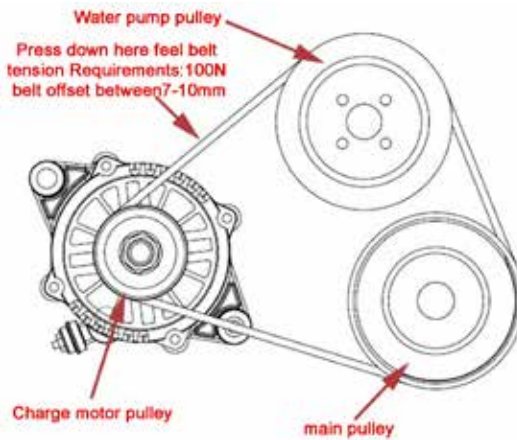

AIR FILTER MAINTENANCE

Take out the air filter cartridge and clean it based on the maintenance table (on page 43). The steps are as follows:

- Remove air filter cover, take out air filter element.
- IMPORTANT. Blow air from the inside of the element toward the outside.
- Clean the filter element using air filter cleaner, dry with compressed air. IMPORTANT! Do not clean with water.
- Replace cracked or damaged air filter elements as soon as possible.
- Reinstall air filter cartridge and air filter cover. Secure clamps.



RADIATOR MAINTENANCE

- Check radiator hose often. Inspect hose clamps for tightness and leakage. If hose clamps are loose, tighten as necessary.
- If radiator hose is bulging or cracking, replace hose immediately!
- Periodically clean the cooling fins of the radiator, using compressed air.

IMPORTANT! Lift lid and blow air from the inside out! Do not force air through radiator from the outside in!

Winter maintenance

When temperatures are under 0°C/32°F, please maintain the engine according to the following specifications.

1. Use winter weight engine oil
2. Check coolant level
3. Use antifreeze tester to check effectiveness of coolant. Add coolant if necessary.
4. For severe cold weather climates we recommend a cold weather kit (sold separately).

Ignition System Maintenance

This engine is equipped with an electronic ignition; the order is 1-3-4-2. Suggested sparkplug: F7RTC (Autolite 4252) or similar type, Using the wrong type of spark plug will damage the engine.

Replacing spark plugs:

- Remove ignition wires from spark plug.
- Using sparkplug socket, remove from cylinder head.
- Annually inspect spark plugs, replace if visible cracking or carbon buildup is seen on insulators.
- Measure the gap of each new spark plug!

NOTE

Correct spark plug gap is 0.9-1.1mm

- Insert new sparkplugs by hand first, then tighten with spark plug socket
- Reinstall ignition wires to correct cylinders.

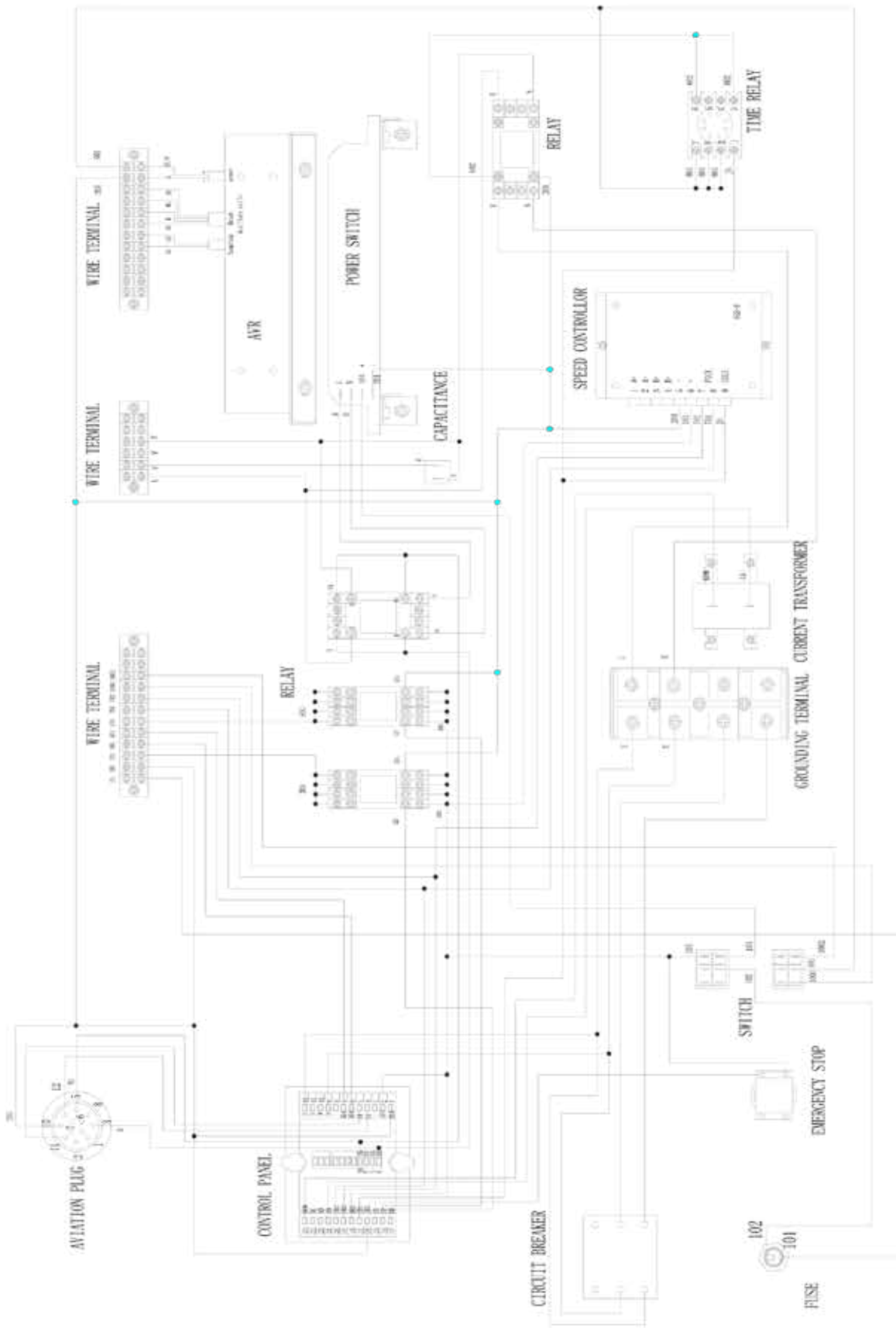

PD20REG 020A5005

440 Single-Phase Genset Circuit Diagram

Engine Maintenance

Utilize the following table to maintain the engine system. This will ensure many years of dependable service. This symbol “●” indicates when a maintenance item needs to be performed.

Items	Remarks	1st Use Check First 30 Hours	Every 50 Hours	Every 100 Hours	Every 200 Hours	Every 400 Hours	Every 1000 Hours
Oil	Check Oil Level	●	●	●			
	Replace	●			●		
Oil Filter	Replace	●			●		
Air Filter	Clean		●		●		
	Replace Filter Element					●	
Spark Plug	Check					●	
	Replace						●
Cooling System	Check Coolant Level and Leakage Occurs	●	●	●	●	●	●
	Clean radiator				●		
	Check the fan running condition				●		
	Check radiator hose connection		●		●		
	Change the coolant					●	
Gas Valve	Check/adjust	●			●		
Gas Line	Check the gas line for damage		●			●	
Exhaust System	Check to see if there is leakage, tighten or replace if needed		●				●
Screws and Nuts	Check all screws & nuts tighten if loose.		●		●		
Water Pump Belt	Adjust tension		●	●			
	Replace						●
Aging Wires	Check all wires for aging situation and if the connectors are loose or not		●		●		
Timing Belt	Depends on the wear pattern	Change Every 1200 Hours					

Additional system maintenance

- Keep the generator clean.
- Add lubrication oil and antirust at the frictional position
- Check all the screws loosen or not, and tighten them

Common Faults and Repair Methods of Generator

Number	Fault Symptoms	Reason & Troubleshooting
1	Generator without power indication	<ol style="list-style-type: none"> 1. Check whether battery is damaged 2. Fuse broken (Check, replace)
2	Generator has power indication but no power output	<ol style="list-style-type: none"> 1. Breaker not open 2. AC output is poorly connected (Check) 3. Check AVR and its fuse 4. Check carbon brush
3	Generator overheating	<ol style="list-style-type: none"> 1. Lack of coolant or pipe blocked (Add coolant or clean up radiator hoses) 2. Thermostat closed or damaged 3. Water pump worn out or damaged (Clean or replace pump) 4. Too much engine oil (Remove the unnecessary engine oil) 5. Damage of rotor bearing (Replace bearing) 6. Radiator blocked or damaged (Clean or replace radiator) 7. Short circuit of stator winding (Check wiring) 8. Rubbing of stator and rotor (Check, adjust gap)
4	Insufficient power output	<ol style="list-style-type: none"> 1. Abnormal gas pressure (adjust pressure) 2. Engine throttle worn out 3. Air filter blocked 4. Some spark or cylinder wire is damaged 5. Too much oil 6. Piston ring worn out

Common Faults and Repair Methods of Engine

Symptoms	Possible Solutions
Controller has no response with power.	Check starting batteries; Check controller connection wirings; Check DC fuse.
Generator shuts down	Check the water/cylinder temperature is too high or not; Check the genset AC voltage; check DC fuse.
Low oil pressure alarm after crank disconnect	Check oil level, then oil pressure sensor and its connections.
High coolant temp alarm after crank disconnect	Check coolant level, then temperature sensor and its connections.
Shutdown Alarm	Check related switch and its connections according to the information on LCD; check auxiliary input ports.
Fail to start	Check fuel oil circuit and its connections; check starting batteries; Check speed sensor and its connections; refer to engine manual.
Starter no response	Check starter connections; check starting batteries.
Stepping Motor Reverse	Cross connect the S11 and S12; Cross connect the S21 and S22; Change configuration (motor reduce direction) via PC.
GOV is out of control.	Check the speed sensor voltage is no less than 2V when cranking. Check the connections of S11, S12, S21, S22.

Common Faults and Repair Methods of Engine

Number	Fault	Check
1	Hard to start	<p>Electrical system fault</p> <ol style="list-style-type: none"> 1. Low battery with not enough power 2. Check battery for loose terminals 3. Starting fault 4. Ignition system fault 5. Spark plug carbon deposit and tarnish 6. Improper gap of spark plugs 7. Spark plug insulation burn out or electrode short circuit 8. Burned out Ignition coil 9. Solenoid valve damage. <p>Handling method</p> <ol style="list-style-type: none"> 1. Check all ignition wires to sparkplugs, make sure all are on secure. 2. Test for spark. Remove ignition wire, using insulated glove hold wire next to plug to see if sparks is present 3. Check the voltage of battery, if under 12.4 volts DC; Recharge 4. Replace or clean spark plug 5. Replace ignition coil, high pressure wire, solenoid valve <hr/> <p>Gas supply system fault</p> <ol style="list-style-type: none"> 1. Check main gas on/off valve (open valve) 2. Pressure reducer or solenoid valve damaged (replace) 3. Supply voltage is too low, cannot open the pipe solenoid and solenoid of the pressure reducer <p>Dealing method for Item 3: replace or charge battery</p> <ol style="list-style-type: none"> 4. Solenoid valve will not connect (settle) 5. Check fuel switch on generator; switch to correct gas(LPG/NG) 6. High pressure in fuel line Handling method: Use the spanner to open the joint softly. If it leaks, the existing parts are undamaged. Use this method to check each one. 7. Low pressure pipe buckling (settle) 8. Oil filter is too dirty (clean) 9. Check LPG/NG pressure

Common Faults and Repair Methods of Engine

Number	Fault	Check
2	Idling unstable	<ol style="list-style-type: none"> 1. Pressure reducer seals did not seat well (reseal) 2. Check the tightening screw of the mixer to see whether it is loose or not, check all of the connections between the gas inlet pipe and mixer for leaks. 3. Check fixed bolt on speed motor to see whether it is loose or not 4. Check the LPG/NG pressure to see whether it is normal or not 5. Check the screw of pressure regulating valve to see whether it is loose or not 6. Check the LPG tank surface to see whether it has frozen over
3	Engine will not operate standby	<ol style="list-style-type: none"> 1. The top dead center signal of cylinder one is not correct 2. Speed signal is not correct Elimination method: check or replace the sensor 3. Temperature of pressure reducing valve is too low 4. Pressure reducer does not work normally; repair or replace 5. Cylinder blow-by: Elimination method: check the cylinder cap of the screw. When necessary, replace the cylinder cap seal.
4	Engine not providing enough power, or consumption of fuel increases	<ol style="list-style-type: none"> 1. 1. Low pressure pipe buckled or too long (settle) 2. Ignition system with not enough ignition power 3. Ignition wires and FBT is not connected correctly 4. Ignition wires and sparkplugs are not connected properly 5. Some of the cylinders miss the ignition <p>Handling method of 3, 4, 5</p> <ol style="list-style-type: none"> 1. Pull out the spark plug, observe pole top to see whether it has burned trace, if there is, then replace the spark plug 2. Use multimeter (XKΩ GEAR) test the resistance of the ignition wires, if damaged, change ignition wires <ol style="list-style-type: none"> 6. Under pressure of the cylinder (check and adjust valve or replace the piston ring) 7. High pressure fuel line blocked or out of shape (clear or replace line) 8. Clean or replace air filter 9. Mixer is not sealed well (replace) 10. The joint part of mixer and throttle leaking (settle) 11. Check gas pressure flow 12. Check whether gas is up to standard, use only high grade LPG 13. Air filter , exhaust system jam,(clean air filter and exhaust pipe) 14. Voltage output instability; (adjust or change)

Common Faults and Repair Methods of Engine

Number	Fault	Check
5	Sudden Stop	<ol style="list-style-type: none"> 1. Safety fuse burned out (replace) 2. Loss of GND connection (settle) 3. Pressure reducer water cycle emerges ice block (Handling method: Clear the water cycle) 4. Pressure reducer low-pressure chamber leaks or diaphragm broken, repair or replace (settle or replace) 5. Air filter is too dirty - check or clean. 6. Solenoid valve fault closed 7. Fault of emergency stop switch
6	Abnormal sound when the engine is operating	<ol style="list-style-type: none"> 1. Ignition timing is early and causes detonation; check distributor timing! 2. Ignition timing is late which causes backfiring of exhaust Dealing methods for Item 1 and 2: adjust the ignition timing on the distributor 3. Tolerance between piston and cylinder is incorrect; it knocks when starting engine, noise dissipates after warmup of engine 4. The gap between piston pin and pin hole is too big, sound is light but clearer during idling 5. The gap between main bearing and connecting rod bearing is worn, can hear especially at lower speed, it sounds heavy and strong 6. Lose crankshaft bearing, can hear noise when idling 7. Broken Valve spring, excessive valve clearance, that can be heard knocking around the cylinder cap Dealing methods for Item 3, 4, 5, 6 and 7: replace the parts, insure proper tolerances and gaps. 8. When the piston hits the cylinder head, you can hear the knocking of metal around the cylinder head Repair method: check the piston and valve to see if damage has occurred
7	Temperature of the engine oil is too high	<ol style="list-style-type: none"> 1. Check around engine compartment for leaks 2. Too much engine load; Reduce load. 3. Too much or not enough engine oil. 4. Down exhaust is too much Dealing methods for Item 4: replace the piston ring or the cylinder sleeve. 5. Blockage in the oil cooler, oil temperature controller valve opened, the temperature is too high, Radiator intake vent is blocked by dirt and debris. 6. Oil mark is not correct (oil viscosity is too high)

Common Faults and Repair Methods of Engine

Number	Fault	Check
8	Pressure of engine oil is low	<ol style="list-style-type: none"> 1. Not enough oil in the oil pan Dealing method: add oil to the selected level 2. Damage of oil pump gear Dealing method: replace the oil pump 3. Blockage in the oil strainer or the oil filter 4. Damage or blocking in the relief valve or the pressure stabilizer spring 5. Blockage or leakage in the oil line Dealing methods for Item 3, 4 and 5: replace parts.
9	Temperature of engine coolant is too high	<ol style="list-style-type: none"> 1. Water thermostat is stuck, method; check and replace thermostat 2. Coolant; test and replace if necessary 3. Engine load if too much; Reduce load 4. Check for proper ventilation around radiator air intake vent
10	Starter fault	<ol style="list-style-type: none"> 1. Starter will not engage. 2. Weak starter engagement.; 3. Starter disengagement is slow or delayed; Prevention method; Check battery connections and voltage.
11	Muffler with black smoke	<ol style="list-style-type: none"> 1. Check air filter for blockage or obstructions. 2. Pressure regulating valve does not work normally Prevention method: Adjust the screw on the valve 3. Ignition timing too early, adjust ignition timing 4. The spark plug does not function normally 5. Ignition wires do not function normally 6. High pressure fuel line does not work normally Project 4, 5, and 6 handling method: replace the related accessories
12	Muffler with blue smoke	<ol style="list-style-type: none"> 1. Check engine oil level, if too much, drain excess oil 2. Replace piston ring 3. Overhaul or replace piston and ring.
13	Muffler with white smoke	<ol style="list-style-type: none"> 1. Engine preheating 2. Water in the cylinder, check head gasket, overhaul the engine cylinder if needed
14	Muffler with flare up and backfire	<ol style="list-style-type: none"> 1. Carburetor floater oil level is too high, adjust the floater 2. Exhaust valve is not totally sealing, polish the valve 3. Ignition timing too late, adjust the ignition timing
15	Load speed, drops too much	<ol style="list-style-type: none"> 1. Clogged fuel line (check and clean fuel line) 2. Dirty air filter (clean the air filter) 3. Improper valve clearance (repair and adjust)

Engine, Primary Parts and Structure

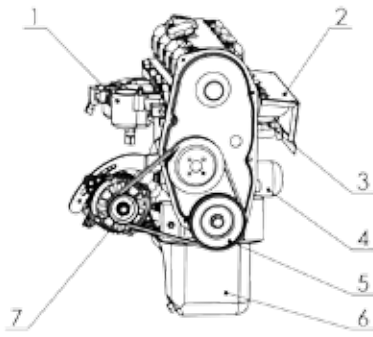

1. Gas inlet manifold
2. Exhaust manifold shield
3. Exhaust pipe manifold
4. Oil filter
5. Crankshaft pulley
6. Oil pan
7. Water pump pulley

Engine Specifications

MODEL#	TR15REG-EB	TR20REG-DB	TR20REG-DB-3
WARRANTY YEARS	2	2	2
ENGINE PART #	465QR	465QR	465QRZ
VOLUME (cc)	998	998	998
COMPRESSION RATIO	9.5:1	9.5:1	9.5:1
IGNITION SYSTEM	ECM	ECM	ECM
ELECTRIC START	YES	YES	YES
ENGINE ALTEERNATOR	QDY112 12V 0.8KW	QDY112 12V 0.8KW	QDY112 12V 0.8KW
FUEL TYPE	NG/LPG	NG/LPG	NG/LPG
CYLINDER BORE & STROKE (mm×mm)	L4-65.5×74	L4-65.5×74	L4-65.5×74
ASPIRATION TYPE	NATURAL ASPIRATION	NATURAL ASPIRATION	SUPER CHARGED
OIL CAPACITY	4.0 L	4.0L	4.0L
SPIN ON OIL FILTER	YES	YES	YES
CYLINDER BLOCK	CAST IRON	CAST IRON	CAST IRON
SLEEVE	CAST IRON	CAST IRON	CAST IRON
CHARGING	14V/70A Charging motor	14V/70A Charging motor	14V/70A Charging motor
Starting current (CCA)	525	550	550
Cooling system	LIQUID COOLED	LIQUID COOLED	LIQUID COOLED
Over heat stop	YES	YES	YES
Low oil pressure stop	YES	YES	YES

Generator Alternator

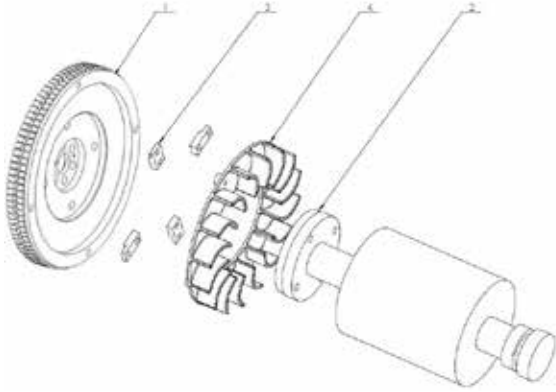

1. Fly wheel
2. Fan connection block
3. Alternator fan
4. Alternator rotor

This generator is directly coupled and attached to the engine.

Generator Alternator Specifications

MODEL#	TR15REG-EB	TR20REG-DB	TR25REG-DB-3
ALTERNATOR TYPE	synchronous, rotating magnetic field	synchronous, rotating magnetic field	synchronous, rotating magnetic field
VOLT. REG. SYSTEM	AVR	AVR	AVR
EXCITATION TYPE	BRUSH	BRUSH	BRUSH
POLES	2	2	2
THD @ FULL LOAD	≤5%	≤5%	≤5%
INSULATION CLASS	F	F	F
STATOR WINDING MATERIAL	COPPER	COPPER	COPPER
ROTOR WINDING MATERIAL	COPPER	COPPER	COPPER
ROTOR OD (mm)	164	164	164
STATOR OUTSIDE DIAMETER (mm)	270	270	270
STACK LENGTH (mm)	Single 160 / three 140	200	200
LAMINATION MATERIAL	cold rolling	cold rolling	cold rolling
CONNECTION METHOD	DIRECT COUPLED	DIRECT COUPLED	DIRECT COUPLED
Motor bearings	6306RS		

Item	Unit	TR15REG-EB	TR20REG-DB	TR20REG-DB-3
RATED POWER (KW)	LPG	15	20	20
	NG	14	18	18
FREQUENCY (HZ)		50	60	60
SPEED (RPM)		3600	3600	3600
RATED VOLT (V)		230 (230/400)	120/240	120/208
RATED CURRENT (A)	LPG	65.2/27.2	83.3	95.8
	NG	60.9/25.4	75	87.5
PHASE		Single-phase	Single-phase	Three-phase
POWER FACTOR		1.0 (0.8)	1.0	1.0
PROTECTION LEVEL		IP23	IP23	IP23
INSULATION		F	F	F
POLE		2	2	2

The generator unit is assembled from a large number of integrated components, including the primary silent cooling system, electronic speed control system, automatic power generating system, multi-energy power generation technologies, intelligent control systems, and ultra-low temperature starting technology.

Generator Components and Enclosure

The main frame and chassis are the primary structures to which all other component pieces are attached. The structure makes up the main noise protection and reduction features of the generator set. Other component parts include the chassis, Radiator compartments, electronic control box compartment, and electronic screen board compartments.

Inner Components:

TR15REG-EB/TR20REG-DB two models:

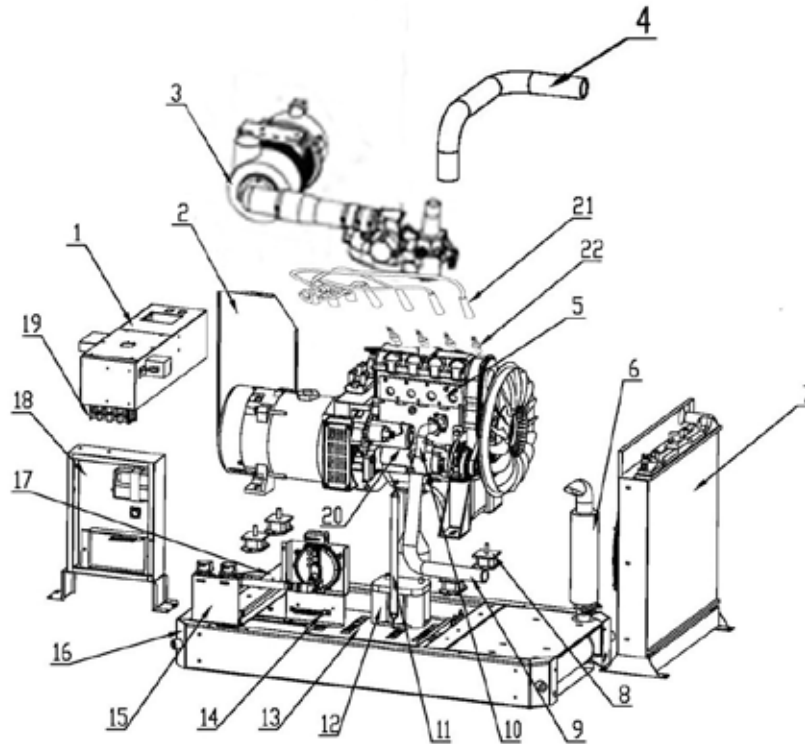

TR15REG-DB / TR20REG-DB / TR20REG-DB-3

ITEMS	Parts Number	DESCRIPTION	QTY	REMARK
1		Electric control system	1	
2		Electric control box support	1	
3		Gas inlet system	1	
4		Radiator part	1	
5		Exhaust part	1	
6		Shock absorption	4	
7		Winding battery	1	
8		Battery base	1	
9		GND	1	
10		Unit base	1	
11		Gas part	1	
12		Motor beams	1	
13		Distribution box	1	
14		Engine alternator	1	

Enclosure Parts for TR15REG-DB / TR20REG-DB / TR20REG-DB-3 models:

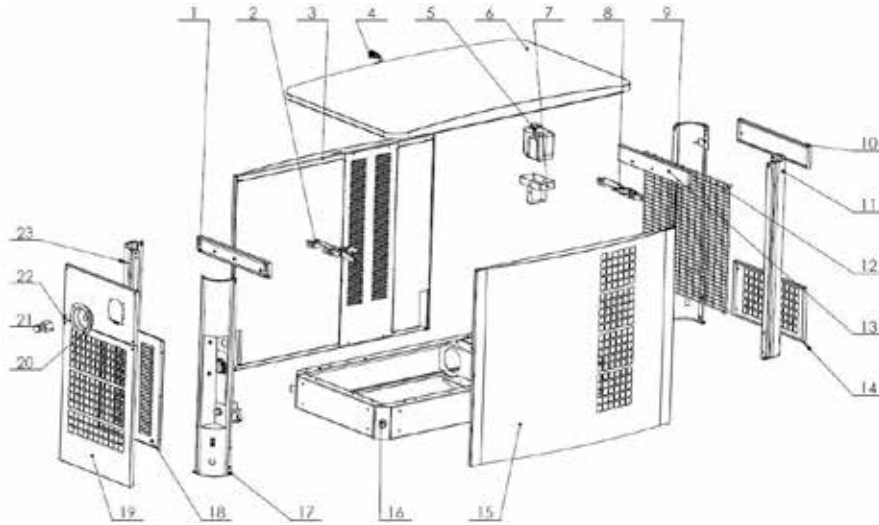

TR15REG-DB / TR20REG-DB / TR20REG-DB-3				
ITEMS	Parts Number	DESCRIPTION	QTY	REMARK
1		canopy right side support	1	
2		Right hinge	1	
3		Front board	1	
4		MS816-1A-1lock	1	
5		Water port	1	
6		Top cover	4	
7		Water port support	1	
8		Left hinge	1	
9		Stand column 1	1	
10		Side board 1	1	
11		R Stand column2	1	
12		Stainless steel board	1	
13		Board left support	1	
14		Side board 2	1	
15		Back board	1	
16		Base subassembly	1	
17		Output terminal	1	
18		Alternator waterproof board	1	
19		Side board 3	1	
20		Emergency stop switch shield	1	
21		Emergency stop switch	1	
22		Side board 4	1	
23		R Stand column 3	1	

Common Formulas

Items	Unit	Name	Conversion
Power	kW	kilowatt	1 kilowatt =1.36horsepower (1kW=1.36Ps)
Torsion	N·m	Newton · meter	1 kilogram· meter=9.81 Newton · meter (1kgf·m=9.81N·m)
Speed	r/min	rotate/minute	
Oil, fuel consumption	g/kW·h	gram/ killowatt·hour	1gram/horsepower·hour=1.36gram/kil- lowatt·hour(1g/Ps·h)=1.36g/kW·h)
Capacity(L)	l	liter	1 litre =1000milliliter(1L=1000ml)
Acreage	cm ²	square centimeter	1square meter=10000 square centimeter (1m ² =10000cm ²)
Pressure	KPa MPa	kilopascal mega-pascal	1kilogram force/square centimeter =98.1 kilopascal =0.0981 mega-pascal (1kgf/ cm ² =98.1kPa=0.0981Mpa)
Power	N	Newton	1 kilogram force =9.8Newton(1kgf=9.8N)
Length	m	meter	1 meter =1000millimeter(1m=1000mm)
Time	min(s)	minute (second)	1minute=60second(1min=60s)
Temperature	K(°C)	Kelvin degree (centigrade)	273K=0°C
Voltage	V	volt	
Current	A	ampere	
Crankshaft Angle	°CA	angle, crankshaft angle	
Quality	g	gram	1 kilogram =1000g(1kgf.m=9.81N.m)

Common Maintenance Parts for Generator

Item	Name	SPEC.	Unit	Quality	Note
1	Charge motor	12V 70A DC	PC	1	
2	Start motor	QDY112	PC	1	
3	Booster pump		PC	1	
4	Carbon brush	L65	PC	1	
5	Water pump belt	4PK-760	PC	1	
			PC	1	TR20REG-DB
			PC	1	
			PC	1	
	Booster pump belt	4PK-720	PC	1	
			PC	1	
6	Manifold inlet pad	465Q	PC	1	
7	Exhaust manifold pad	465Q-1	PC	1	
8	Ignition coil	465QR	PC	1	
9	Crankshaft position sensor	465Q5	PC	1	
10	Water temperature switch	100°C	PC	1	
11	Solenoid valve	QRY-4	PC	1	
12	Gas valve	HODHLKN	SET	1	
13	Fan		PC	1	Outer annulus size (Φ375)
14	Radiator	LD465	PC	1	
15	Mixer assembly	015A0372	PC	1	
16	ETC		SET	1	
17	Air filter	K1330	PC	1	
18	Air filter pipe	Φ50-Φ65	PC	1	
19	Oil filter sapnner	HM-501	PC	1	
20	Spark plug socket	L114	SET	1	
21	Spark plug	K6RTC	PC	4	
22	Universal wheel	Φ125-32	PC	2	
23	Directional wheel	Φ125-32	PC	2	
24	Foot support		PC	4	
25	Temperature control	45°C, 90°C	PC	1	
26	Heating pipe	500W AC220V	PC	1	
27	Waste pipe	015A0370	PC	1	
28	Wire harness		SET	1	
29	ECU	20KW/120V/240V	PC	1	
30	Control panel	HSC940	PC	1	

Additional Troubleshooting Procedures

1. Simple check

- Battery voltage, working voltage.
- Sufficient fuel supply – check that fuel valve is open?
- Is the entrance and pressure reducer to gas solenoid valve properly open?
- High voltage normal or not: spark plug).
- Speed sensor signal normal or not.
- Observe exhaust gas (color, smell, sound and feel).
- Replace the suspected parts only with a new certified genuine parts , then observe operation.
- If fault is repaired then, observe start and listen to engine.
- If the fault appears again, verify that genuine parts are being used and properly installed.

Common Faults and Repair Methods of Genset

Genset will not start

Perform the following methods:

1. Basic check:

- Make sure unit is filled with engine oil.
- Make sure unit is filled with enough coolant.
- Make sure gas valve is open. Check for suitable gas pressure.
- Check whether the battery is sufficiently charged or not.
- Check the main power input when starting the unit automatically.
- Check the power indicator light on digital controller to make sure it's on.
- Check Gas flow pressure: turn the transition nut on pressure regulator to adjust proper gas flow .
- Battery voltage test: use a multi-meter to test the battery voltage, if voltage is 12.6 V, battery has enough power; if voltage is below 12.6V, recharge battery.
- Cylinder wire check: see picture below, the gap between the conductor and engine is 3-5mm, start the start motor, check for spark.



- Spark plug check: contact spark plug with engine block. Initiate starter motor, observe whether the spark plug is sparking to the ground contact on engine block. If no spark, replace plug.



- Igniter test: use a multi-meter to test the socket voltage, it should read 12V

Test the first two
Corresponding positions

- Check starter motor: when generator exercises initial start, the main shaft of the Starter motor should engage and rotate substantially to open throttle.
If starter motor is not operating properly, replace starter.



Generator hunting elimination:

After starting generator, if there is too much irregular pattern vibration, this means generator is hunting (frequency fluctuation $>2\text{Hz}$). The power output produced while hunting will not influence the use of electricity (except with high precision digital equipment, which requires Low harmonic distortion and high quality electric frequency). Still, this should be adjusted and repaired promptly.

1. General checking:

- Check whether the gas pressure normal or not.
- Check whether the fuel line is blocked.
- Check whether the speed sensor is loose or damaged.
- Check starter.

2. Measuring method:

- Connect a pressure meter in the inlet pipe, open the gas valve, observe the data on pressure gauge.
- Observe whether the gas valve is extruded or not.
- Open the fuel switch; see if there is a hum from the solenoid valve.
- Use the multi-meter Ohm level, measure the two joints of the speed sensor, there should be resistance.
- Check whether the electrical speed regulation has 12v DC power input.

No Power Output: Troubleshooting

After starting the generator, there is no power output under the right speed and frequency, perform the following steps to check and solve issues:

- Check whether the battery has enough voltage (Voltage $>12\text{V}$).
- Check circuit for proper voltage input and output.
- Connect the voltage regulator and battery, check whether the regulator and the battery have the same voltage input.
- When the generator operates normally, the carbon brush should have approximately 70 volts.

Measuring method:

- Use the multi-meter 20V DC to measure the voltage of battery, voltage regulator input.
- Use the multi-meter 200V DC to measure the voltage of the carbon brush.

Repair method:

- When the voltage regulator has input but no output, there may be two possible reasons, (output short circuit protection, secondary winding protection). Cut power, discharge regulator and reconnect. The common protection time is 90 seconds, but under abnormal condition it will need about 1 hour.



Ingersoll Rand (NYSE:IR) advances the quality of life by creating comfortable, sustainable and efficient environments. Our people and our family of brands—including Club Car®, Ingersoll Rand®, Thermo King® and Trane®—work together to enhance the quality and comfort of air in homes and buildings; transport and protect food and perishables; and increase industrial productivity and efficiency. We are a \$13 billion global business committed to a world of sustainable progress and enduring results.



ingersollrand.com



TRANE®

Installer's Guide

Home Standby Generator Automatic Transfer Switch

- TR15REG-DB (15Kw single-phase)
- TR20REG-DB (20Kw single-phase)
- TR20REG-DB-3 (20Kw three-phase)

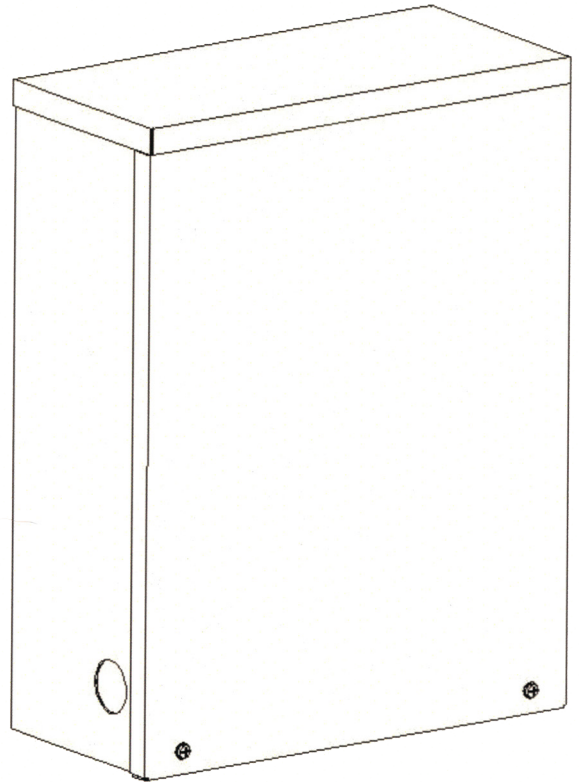

Note: "Graphics in this document are for representation only.
Actual model may differ in appearance."

⚠ SAFETY INSTRUCTIONS

Only qualified personnel should install and service the equipment. The installation, starting up, and servicing of home standby generator equipment can be hazardous and requires specific knowledge and training. Improperly installed, adjusted or altered equipment by an unqualified person could result in death or serious injury. When working on the equipment, observe all precautions in the literature and on the tags, stickers, and labels that are attached to the equipment.

Table Of Contents

Functions	3
Safety Instructions	4
Mounting & Connections	5
Operation Instructions	6
Fault Inspection and Troubleshooting	7
Specifications	8
DKG-173 Controller	9
DKG-173 Specifications	10
Application Rang	11
Typical Connection Diagram	12
Relevant Models and Implications	13
Product Appearance and Parts Description	14
MCQ3 Technical Specifications	15
MCQ2 Technical Specifications	17
Installation Dimensions	18
Box Matching Dimensions	20

Preface

The Automatic Transfer Switch (hereafter referred to as ATS) uses world-famous ATS or AC Contactors as the main switches, and are manufactured from advanced and closely-controlled production processes. It is combined with all our automatic generators to form a complete and thorough Automatic Transfer System.

The DKG-173 Transfer Controller is installed inside the ATS, which applies to three phase or single phase systems with phase voltage of 220v AC. Pluggable connectors are connected with external connections, which make the maintenance, inspection, or replacement easy and convenient.

We have 125A single phase ATS, 125A three phase ATS, and 200A single phase ATS for your different needs in various conditions.

Functions

ATS has control functions (such as generator start-up delay, mains restore delay and voltage detection, etc.). When the ATS is connected to automatic generators, the generator's control box will send the transfer signal in order to transfer loads automatically. It can operate with our automatic control systems or other brands that have remote-start self-control functions which are simple and economic.

Control Mode

Generation/Automatic/Mains

LED Display

Mains Available

Mains on Load

Generator Available

Generator on Load

Parameter Settings

M. VOLT. SET: Mains Voltage Normal Value Setting, 75%-100% settable

VOLT. 100% = 170-300V

MCT: Closing Delay Time after Mains Voltage returns to normal, 0-40 MIN. settable

GCT: Closing Delay Time after Generator Voltage returns to normal, 0-40S settable

G. VOLT. SET: Generator Voltage Normal Value Setting, 75%-100% settable

VOLT. 100% = 170-300V

Protection Function: Mains/Generator low voltage protection

Important Safety Instructions

SAVE THESE INSTRUCTIONS! Read the following information carefully before attempting to install, operate or service this equipment. Also read the instructions and information on all tags, decals, and labels that may be affixed to the transfer switch. Throughout this publication, and on tags and decals affixed to the generator, DANGER, WARNING, CAUTION and NOTE blocks are used to alert personnel to special instructions about a particular operation that may be hazardous if performed incorrectly or carelessly. Observe them carefully. Their definitions are as follows:



After this heading, read instructions that, if not strictly complied with, will result in personal injury or property damage.



After this heading, read instructions that, if not strictly complied with, may result in personal injury or property damage.



After this heading, read instructions that, if not strictly complied with, could result in damage to equipment and/or property.



This symbol points out important safety information that, if not followed, could endanger personal safety and/or property.



This symbol points out potential explosion hazard.



This symbol points out potential fire hazard.



This symbol points out potential electrical shock hazard.

Important Safety Instructions

- Remove all jewelry (such as rings, watches, bracelets, etc.) before working on this equipment.
- If work must be done on this equipment while standing on metal or concrete, place insulative mats over a dry wood platform. Work on this equipment only while standing on insulative mats.
- Never work on this equipment while physically or mentally fatigued.
- Keep the transfer switch enclosure door closed and bolted at all times. Only qualified personnel should be permitted access to the switch interior.

Equipment Description

The automatic transfer switch is used for transferring electrical load from a UTILITY (NORMAL) power source to an EMERGENCY (STANDBY) power source.

Mounting

- This model automatic transfer switch is designed for use only with Trane home standby generator sets.
- Install the transfer switch as close as possible to the electrical loads that are to be connected to it. Mount the switch vertically to a rigid supporting structure.
- To prevent switch distortion, level all mounting points. If necessary, use washers behind mounting holes to level the unit.

Connecting Power Source and Load Line

- Wiring diagrams and electrical schematics are provided in this manual.
- Before connecting wiring cables to terminals, remove any surface oxides from the cable ends with a wire brush. All power cables should enter the switch next to transfer mechanism terminals. If ALUMINUM conductors are used, apply corrosion inhibitor to conductors.
- Tighten terminal lugs to the torque values as noted on the decal located on the inside of the door. After tightening terminal lugs, carefully wipe away any excess corrosion inhibitor.

Operation Instructions

Automatic Mode

1. Move the control switch of the ATS Control Panel on the AUTO position, the control mode of the generator is "AUTO".
2. When mains are on load, the indicators "Mains Available" and "Mains On Load" will light up.
3. When mains failure occurs or utility is abnormal, the generator will be controlled by the Control Box for "Start-up Delay" automatic start.
4. When the generator has started and the voltage is normal, the "Generator Available" indicator lights up. If the ATS automatically switches the generator on, and the "Generator On Load" indicator lights up.
5. When the utility is restored, the "Mains Available" indicator lights up. The ATS automatically transfers to the mains side after the generator control box has sent the "Mains on Load" signal. The "Generator on Load" light goes off and the "Mains on Load" indicator lights up.
6. When the ATS control box detects that generator voltage is normal, the "Generator Available" indicator lights up. The ATS transfers to the generator side when the GCT time setting is set on conditions of "Generator on Load".

Fault Inspection and Troubleshooting

All our products will be strictly inspected before delivery in order to guarantee the quality of products. Unreliability caused by users' improper installation and misuse can be checked in accordance with the following instructions. Please contact us or the nearest dealer for help if faults are still unresolved.

1. The Main Switch has no action

- A. The start-up delay has not finished. Please wait.
- B. Verify whether the lines are correctly connected, especially the mains power source, the generator power source, and load lines.
- C. Check if the control lines from the ATS to the Control Box are correctly connected.

2. Indicators do not work

- A. Verify whether lines are correctly connected or not, especially the mains power source, the generator power source, and load lines.
- B. Check if the setting of each control panel delay potentiometer is correct.

3. Generator does not start in case of utility outage

- A. Verify whether the ATS Control Panel control switch and generator are set in the "AUTO" position.
- B. Check if the control lines from ATS to the generator's Control Box are correctly connected.

Specifications	
Outside Size :	495 x 375 x 180
Operation Temp	-20°C to 70°C (-4°F to 158°F)
Storage Temp	-40°C to 85°C (-40°F to 185°F)
Humidity	5 to 95% cannot freezing
Weight (Kg)	17.5

Controller DKG-173 Specifications	
Generating voltage	170-300V-AC (Ph-N phase line-null line)
Mains voltage	170-300V-AC (Ph-N phase line-null line)
Generator contactor delay	1s to 40s, adjustable
Mains regain delay	1s to 40s, adjustable
MCB relay output	10A@250V-AC
GCB relay output	10A@250V-AC
Remote start relay output	10A@250V-AC/28V-DC
Operation temp. range	-30°C (-22°F) to 70°C (158°F)
Storage temp. range	-30°C (-22°F) to 80°C (176°F)
Max Humidity	95% non-condensing (non-condensation)
Size	70 x 115 x 66mm (W x H x D)
Weight	180g
Installation method	DIN-rail mounting
Enclosure material	Heat Resistant ABS/PC (UL94-VO) plastic
Protection lever	IP20

Automatic Transfer Switch Spec Data	
Working Volt (Ue)	AC400V
Rated Isolation Volt	690V
Frequency	60HZ
Rated Working Current (A)	200A
Rated Short-time Withstand Current	10KA
Rated Limited Short-circuit Current	25KA
Operating Torque (N.m)	12
Conversion Time (S)	< 80
Mechanical Endurance (times)	10000
Poles	2P

DKG-173

DIN RAIL MOUNTED ATS CONTROLLER WITHOUT DC SUPPLY

DESCRIPTION

The DATAKOM model DKG -173 is a DIN Rail mounted ATS controller not requiring DC supply.

The unit monitors 3-phase mains voltages, sends remote start command to the generating set and performs changeover of both generator and mains contactors.

The Front Panel LED provides information about mains and generator power availability as well as contactor positions.

Mains return delay and genset contactor delays are adjustable between 1 and 40 seconds through front panel knobs.



FEATURES

- DIN Rail mounted
- No DC supply required
- Adjustable MCB and GCB delays
- 10A/250V AC MCB and GCB outlets
- 10A/28V DC/250V AC remote start output
- Isolated mains and generator set inputs

OPERATION

When the mains exist while all its phase voltage are below the limit 1/

- If R, MC, RST LEDs are on.
- The MCB terminal is supplied with voltage R.
- The REMOTE START relay contact is open.
- The REMOTE START relay contact opens.

If any phase voltage of mains is over the limit

- R, MC, RST LEDs turn off.
- The MCB terminal is open.
- The REMOTE START relay contact closes.

The REMOTE START output is expected to provide a generator set running condition.

When the generator set voltage G is over the limit

- The G LED turns on
- At the expiration of the generator set contactor delay, the GC LED turns on and the GCB terminal is supplied with voltage G.

DKG-173 Specifications

Inputs:

R-S-T: mains phase voltages
NEUT-MN: mains neutral terminal
G: generator phase voltage
NEUT-GN: generator neutral terminal

Outputs:

MCB-MAINS CONTACTOR: normally open relay output connecting the phase-R voltage to the terminal (10A @ 250V AC)
GCB-GENERATOR CONTACTOR: normally open relay output connecting the phase-G voltage to the terminal (10A @ 250V AC)
REMOTE START: normally open engine start request relay output (10A @ 28V DC / 250V AC)

LED Indicators:

G: generator set voltage present
GC: generator set contactor closed
R: power supplied from mains
RST: mains voltage present
MC: mains contactor closed

Technical Specifications:

Alternator voltage:
170-300V AC (Ph-N)
Mains Voltage:
170-300V AC (Ph-N)
Generator contactor delay:
1 to 40 seconds (adjustable)
Mains return delay:
1 to 40 seconds (adjustable)
MCB relay output:
10A @ 250V AC
GCB relay output:
10A @ 250V AC
Remote start relay output:
10A @ 250V AC / 28V DC
Operating temperature:
-30 C (-22 F) to 70 C (158 F)
Storage temperature:
-30 C (-22 F) to 80 C (176 F)
Maximum humidity:
95% non-condensing

Dimensions:

70 x 115 x 66mm (W x H x D)

Weight:

180g (approx.)

Installation:

DIN Rail mounted

Case Material:

High Temp. ABS/PC (UL94-V0)

IP Protection:

IP20

Conformity (EU directives)

-2006/95/EC (low voltage)
-2004/108/EC (EMC)

Norms of reference:

EN 61010 (safety requirements)
EN 61326 (EMC requirements)



Application Range

MCTRANS Series Dual power transfer switches (ATSE MCTRANS Series Dual power transfer switches (ATSE) are advanced products which adopted the early twentieth century technology. It can be used for two-way power source infrequently transferred switched with rated insulation voltage AC800V and DC250V, rated current 20 to 5000A, rated frequency 50 or 60 Hz.

It is mainly applied in occasions where need uninterruptible power supply, such as malls & office buildings, post communications, fire-fighting, military, mines, ship & vessel, escalator & elevator and industrial assembly lines, etc. in order to meet the assembly lines, etc. in order to meet the requirements of providing more reliable power sources.

The products are characterized by its small size, easy operation, fast switching speed and high reliability.

MCQ2 Model is double segments (without Neutral Position, transfer sequence: Mains to Generator) dual power transfer switch.

MCQ3 Model is three segments (with Neutral Position, transfer sequence: Mains to Neutral to Generator) dual power transfer switch.

Standards

IEC60947-1/GBT.14048.1-2000 Low-voltage switch Equipment and control Equipment/General rules

IEC60947-3/GBT.14048.3 Low Voltage Switch Equipment and Control Low Voltage Switch, Isolator, Isolation Switch, and Combined Electronic Equipment

IEC60947-6/GBT.14048.11 Automatic Change-over Switch Circuit

Typical Connection Diagram

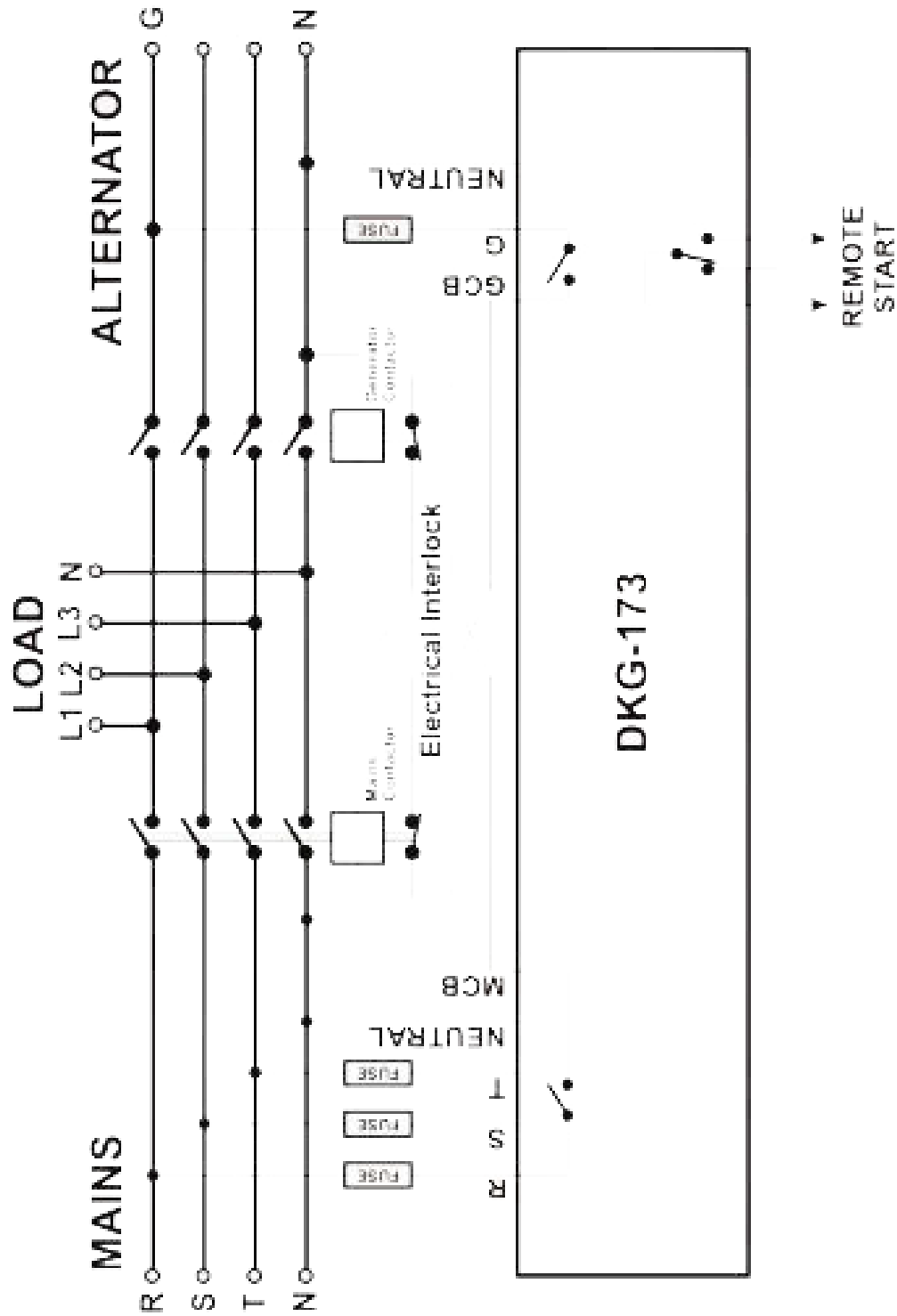

Relevant Models and Implications

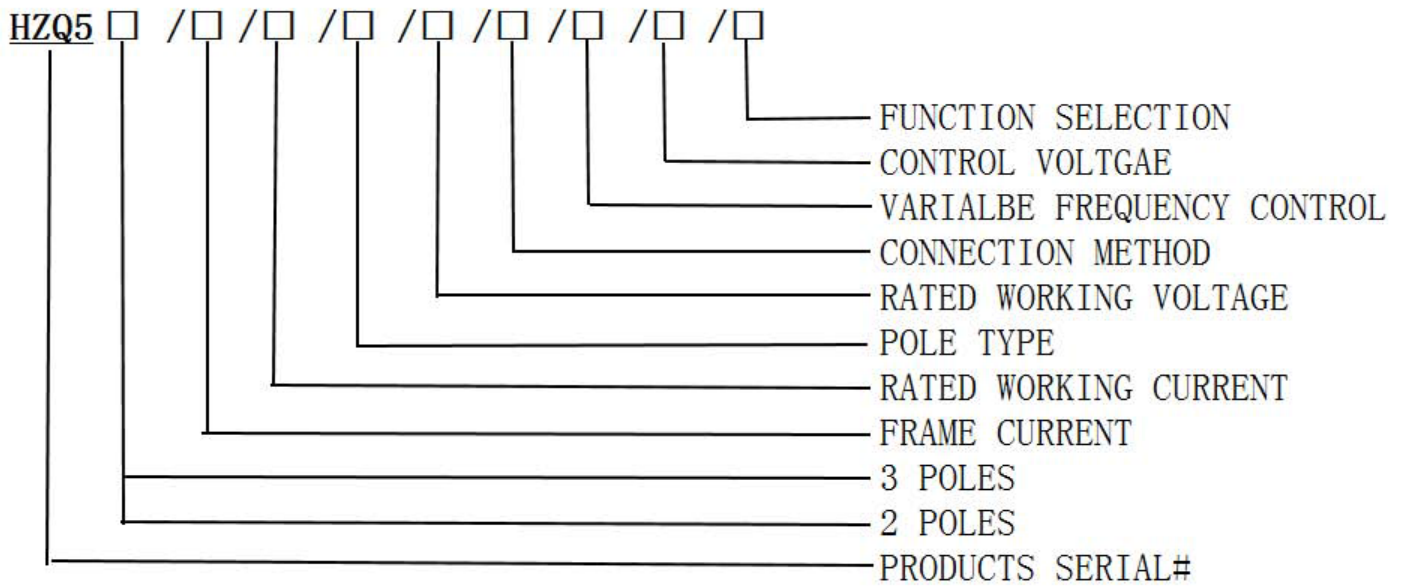

Model	Rated Current	Pole	Rated Voltage	Wiring Method	Control Voltage
MCQ3 three segments with open position	20 40 80 100	2: 2 poles	690V	F: Front	2: 230V AC
MCQ2 double segments without open position	125 160 200 225	3: 3 poles	400V	B: Back	4: 400V AC
	250 350 400	4: 4 poles			

Product Appearance and Parts Description

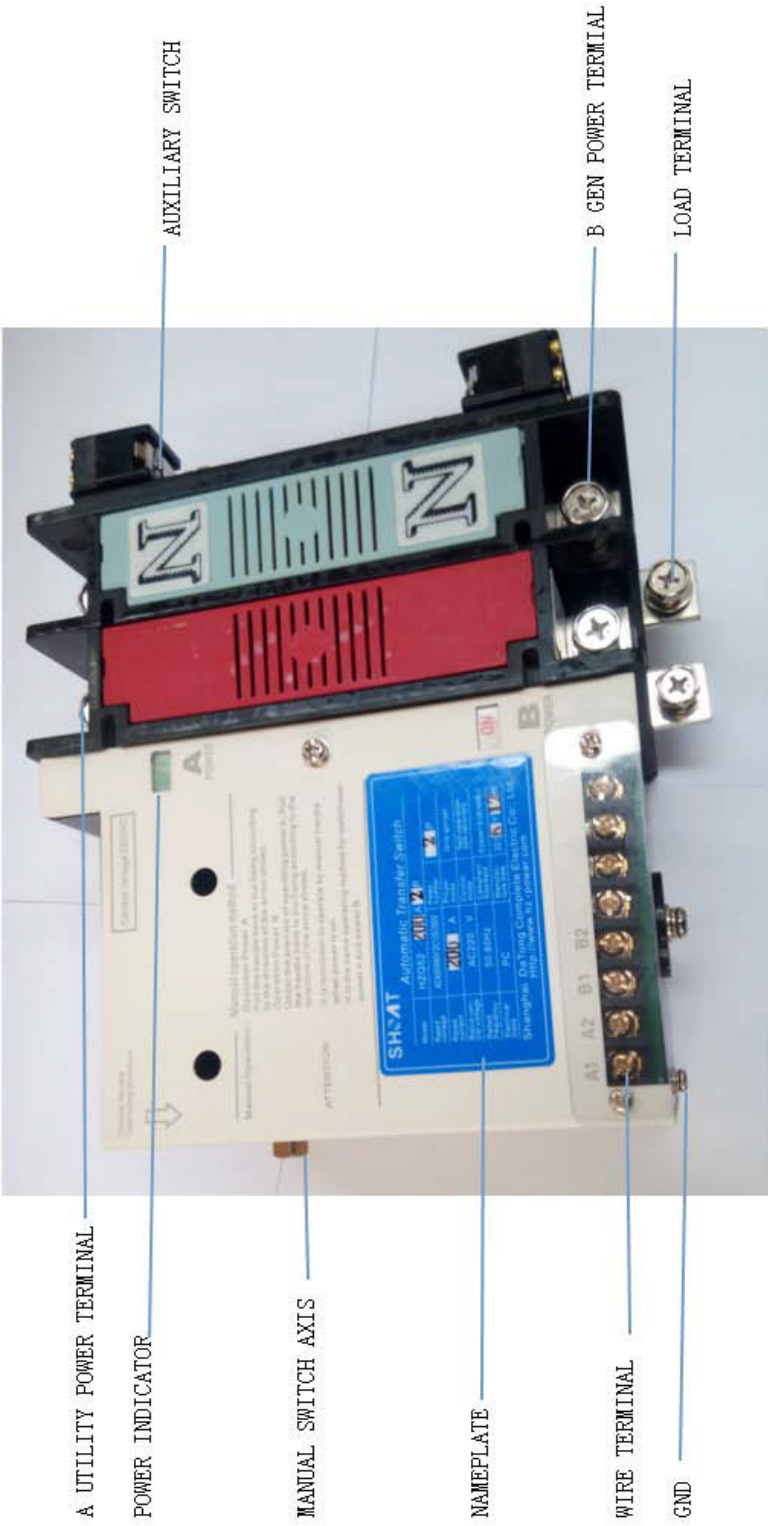

MCQ3 Main Technical Specifications

Model		MCQ3														
Rated Voltage																
Rated Current		20A-63A			80A-125A			160A-250A			350A-500A			630A-800A		
Coil Quantity		Double Coils														
Wiring Method		Front														
Pole		2P	3P	4P	2P	3P	4P	2P	3P	4P	2P	3P	4P	2P	3P	4P
Weight (Kg)		5.5	6	6.5	6	6.5	7	6	8	10	11	14	18	25	33	42
Operating Current		DC100V (A)		3	3	4	3	3	4	3	4	5	7	6	6	6
		AC100V/110V (A)		3	3	4	3	3	4	3	4	5	7	6	6	6
		AC200V/220V (A)		1.5	1.5	2	1.5	1.5	2	2.5	2.5	2.5	3.5	3	3	3
Tripping Current		DV100V														
		AC100V/110V														
		AC200V/220V														
Short-time Withstand Current		5KA			10KA			25KA			30KA			37.5KA		
Rated Conditional Short Circuit Current		12.5KA														
Connecting and Breaking Capability		AC-33B (101e Connect • 81e Break) cos=0.35 DC-33B 1.1le Connect • 1.1le Break L/R = 1ms														
Performance		Switching Time		A power side		Control		55ms		60ms		100ms				
				Break		20ms		25ms		30ms						
		B power side		Control		80ms		80ms		135ms						
		Break		20ms		20ms		30ms								
Life		Electrical: 2500 operations, Mechanical: 10000 operations														
Operating Recycles		120 operations / hour														
Auxiliary Switch		A power side 1C, B power side 1C, Switch Capacity AC100V 5A AC200V 2.5A DC100V 0.5A														
Accessories		Manual Operation Handle														

MCQ3 Main Technical Specifications (continued)

Model		MCQ3															
Rated Voltage																	
Rated Current		1000A		1250A		1600A		2000A		3150A		4000A		5000A			
Coil Quantity		Double Coils															
Wiring Method		Back															
Pole		2P	3P	4P	2P	3P	4P	2P	3P	4P	2P	3P	4P	2P	3P		
Weight (Kg)		30	39	49	31	40	51	36	47	59	95	115	135	110	150		
DC100V (A)		6	6	8	6	6	6	7	8	9	8	10	12	10	12		
AC100V/110V (A)		6	6	8	6	6	6	7	8	9	8	10	12	10	12		
AC200V/220V (A)		2	3	4	3	3	4	3.5	4	4.5	4	5	6	7	8		
DC100V		2A															
AC100V/110V		2A															
AC200V/220V		1A															
Short-time Withstand Current				22KA				25KA				35KA		50KA			
Rated Conditional Short Circuit Current				50KA				55KA				55KA		80KA			
Connecting and Breaking Capability		AC-33B (10Ie Connect • 8Ie break) cos=0.35 DC-33B 1.1Ie Connect • 1.1Ie Break L/R = 1mst															
Performance		Switch- ing Time		A power side		Control		115ms		115ms		180ms		140ms		200ms (190)	
				Break		Break		25ms		25ms		25ms		30ms		30ms (30)	
Life		B power side		Control		Control		145ms		150ms		150ms		190ms		220ms (240)	
				Break		Break		25ms		25ms		25ms		30ms		30ms (30)	
Operating Recycles		Electrical: 2000 operations Mechanical: 8000 operations															
Auxiliary Switch		120 operations / hour															
Accessories		30 operations / hour															
		A power side 1C, B power side 1C, Switch Capacity AC100V 5A AC200V 2.5A DC100V 0.5A															
		Manual Operation Handle															

MCQ2 Main Technical Specifications

Model		MCQ2											
Rated Voltage		AC400V / 690V					DC125V / 250V						
Rated Current		20A-63A		80A 100A 125A			160A 200A 225A 250A						
Coil Quantity		Double Coils											
Wiring Method		Front											
Pole		2P	3P	4P	2P	3P	4P	2P	3P	4P	2P	3P	4P
Weight (Kg)		4.5	5	5.5	5	5.5	6	6	8	10			
Operating Current	DC100V (A)	3	3	4	3	3	4	3	4	3	4	5	
	AC100V/110V (A)	3	3	4	3	3	4	3	4	3	4	5	
	AC200V/220V (A)	1.5	1.5	2	1.5	1.5	2	1.5	2	1.5	2	2.5	
Tripping Current	DC100V	1A											
	AC100V/110V	1A											
	AC200V/220V	0.5A											
Short-time Withstand Current		5KA					10KA						
Rated Conditional Short Circuit Current		12.5KA					25KA						
Connecting and Breaking Capability		AC-33B(10le connect • 8le break) cos=0.35 DC-33B 1.1le connect • 1.1le break L/R = 1ms											
Performance	Switching Time	A power side	55ms										
		Break	20ms										
	Life	B power side	80ms										
		Break	20ms										
Operating Recycles		Electrical: 2500 operations, Mechanical: 10000 operations 120 operations / hour											
Auxiliary Switch		A power side 1C, B power side 1C, Switch Capacity AC100V 5A AC200V 2.5A DC100V 0.5A											
Accessories		Manual Operation Handle											

Note: the outside dimension of MCQ2 Models Rated Current from 450A to 500A are the same as the 340A to 500A Models of the MCQ3.

Installation Dimensions

20A-63A

Panel Safe Distance (S1 Dimensions: 30mm (400V), 60mm (690V))

(5) HZQ53 630A ~ HZQ53 1600A

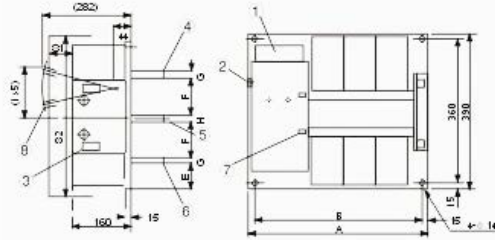

S1: 45mm(400V), 90mm(690V)
S2: 430mm(400V), 450mm(690V)

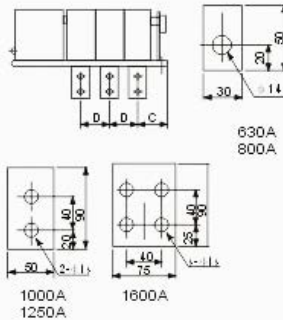

Type	630A 800A	1000A 1250A	1600A	
A	2P	340	370	410
	3P	405	450	510
	4P	470	530	610
B	2P	310	340	380
	3P	375	420	480
	4P	440	500	580
C	80	88	97.5	
D	65	80	100	
E	60	60	57	
F		117.5		
G		12/15	15	
H		15		

80A-125A

Panel Safe Distance (S1 Dimensions: 30mm (400V), 60mm (690V))

(2) HZQ53 80 ~ 125A
HZQ52 80 ~ 125A

S1: 30mm(400V), 60mm(690V)

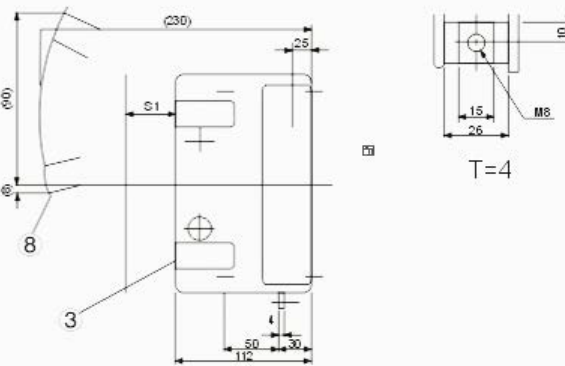
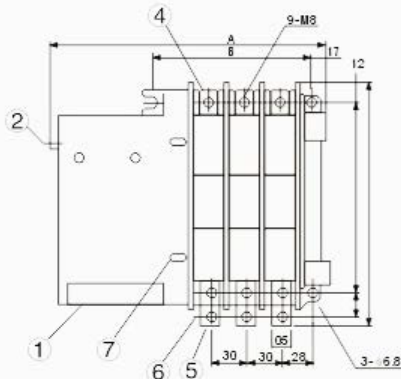

160A-250A

Panel Safe Distance (S1 Dimensions: 30mm (400V), 60mm (690V))

(3) HZQ53 160 ~ 250A
HZQ52 160 ~ 250A

S1: 30mm(400V), 60mm(690V)

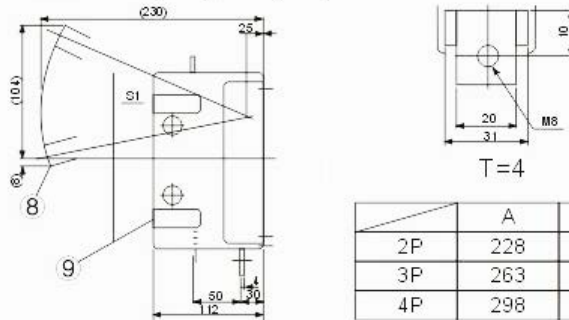
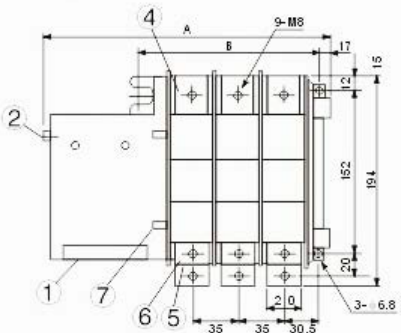

	A	B
2P	228	113
3P	263	148
4P	298	183

- 1 Operation Circuit Terminal
- 2 Manual Operation Handle Entrance
- 3 Auxiliary Switch
- 4 A Power Side Main Circuit Terminal
- 5 Loaded Side Main Circuit Terminal
- 6 B Power Side Main Circuit Terminal
- 7 ON / OFF Option Buttons
- 8 Manual Operation Handle (removable)

Box Matching Dimensions

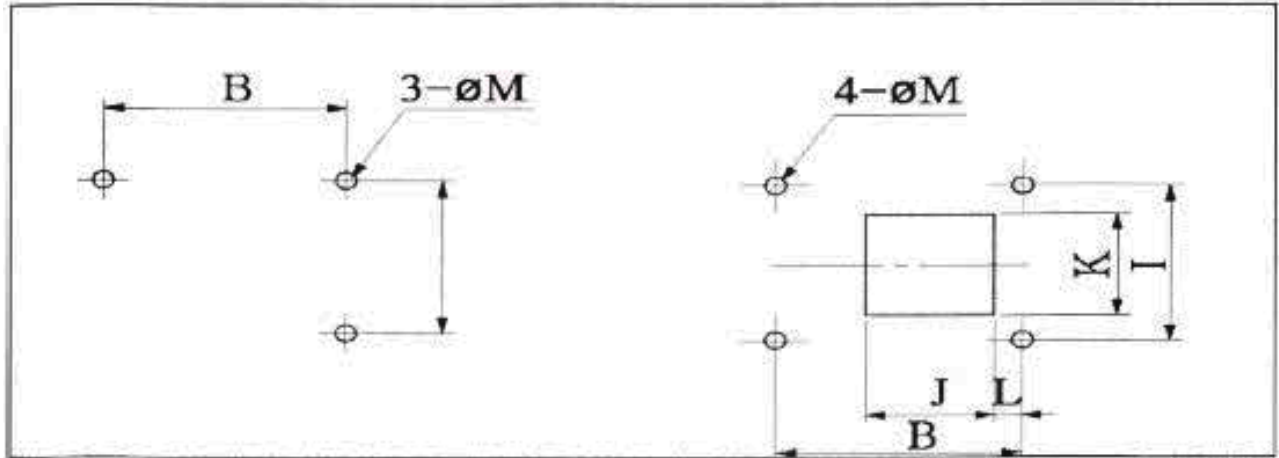

Figure I. Fixing Bolt Hole (front)

Figure II. Fixing Bolt Hole and Panel Hole (back)

Model	MCQ3 100	MCQ3 250	MCQ3 400	MCQ3 630	MCQ3 800	MCQ3 1000	MCQ3 1250	MCQ3 1600	MCQ3 2000	MCQ3 2500	MCQ3 3150	MCQ3 4000	
B	2P	103	113	164	310	310	340	340	380	460	500	685	685
	3P	133	148	224	375	375	420	420	480	595	645	915	915
	4P	163	183	284	440	440	500	500	580	790	790	1155	1155
I	152	152	200	360	360	360	360	360	420	420	420	420	420
J	2P	-	-	-	145	145	180	180	225	285	310	460	460
	3P	-	-	-	210	210	260	260	325	420	455	690	690
	4P	-	-	-	275	275	340	340	425	600	600	920	920
K	-	-	-	330	330	330	330	330	350	350	350	350	350
L	-	-	-	25	25	23	23	20	20	20	20	65	65
M	5.8	5.8	9	14	14	14	14	14	14	14	14	14	14
Figure	I			II									

Note:

1. Keep the wire bending pressure from placing directly on the terminal when connecting the main circuit terminal.
2. For the arc extinction distance outside the arc chute, please see the Outside Dimensions Part Figure I and Figure II.
3. Please connect the grounding wire to the terminal marked

Manual Operation Instructions

The terminals may be melted when operation under load due to different individual operation differences. Avoid using manual operation method if possible. Please operate as the following instructions if the manual operations are unavoidable.

1. Completely no operation power supply
2. When checking on operation mechanisms and contacting terminals under non-loaded conditions
3. In case of failure and electric start can not be operated

Double segments A, B power side Control Method



Operate the handle manually, the notch will be inserted on the left side



Pull down the handle to control the switching of A/B power



Verify by checking the ON / OFF indicator



Take down the handle after the operation

Triple segments A, B power side Control Method

1. Manual tripping method

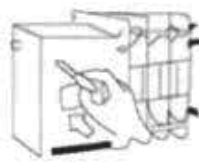

Insert screwdriver into the TRIP hole and press inside in order to trip after taking down the handle (please verify by checking the ON / OFF indicator)

2. A Side power control method



Operate the handle manually, the notch will be inserted on the left side



Pull up the handle for control

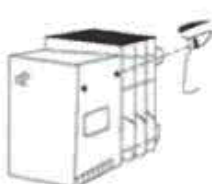

Verify by checking the ON / OFF indicator



Take down the handle after the operation

2. B Side power control method



Operate the handle manually, the notch will be inserted on the left side

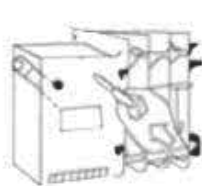

Insert screwdriver into the SELECT hole and press inside

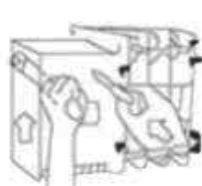

Press and hold, pull up the handle at the same time, and the B side switch is now being controlled

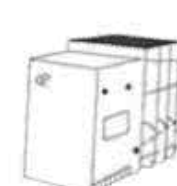

Verify by checking the ON / OFF indicator. Take down the handle after the operation

Typical Connection Diagram

MCQ2 Inside circuit diagram

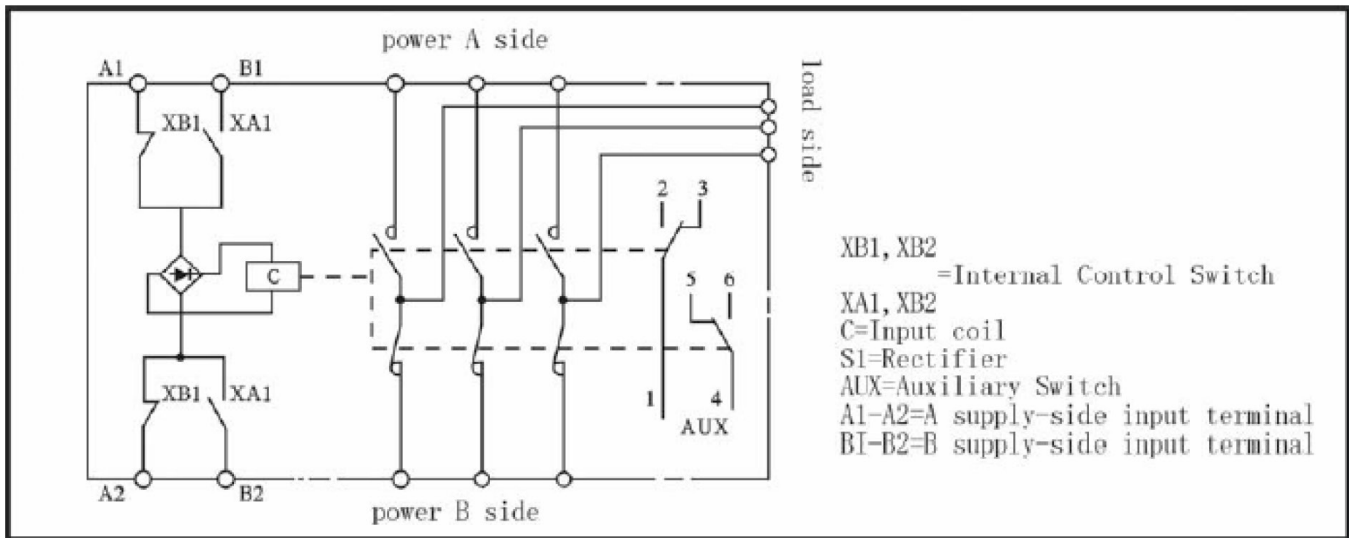

MCQ3 inside circuit diagram

Two power OFF state

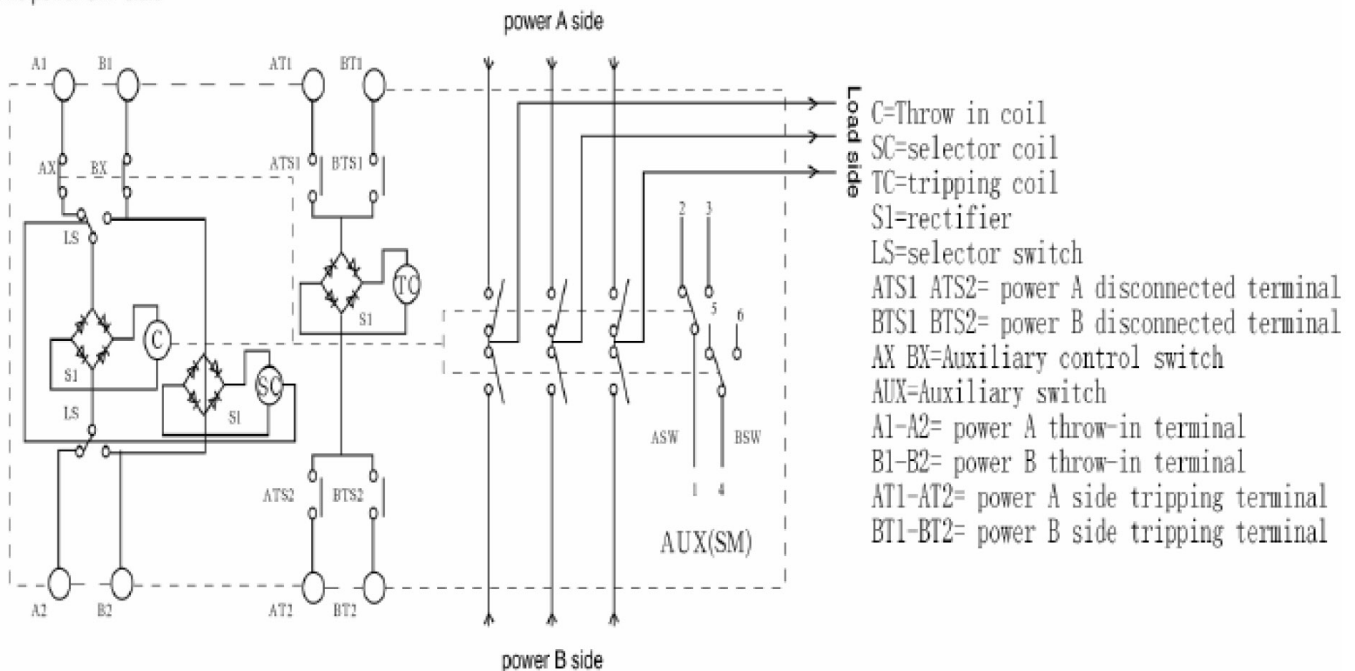

ATS Single Phase Connection Diagram

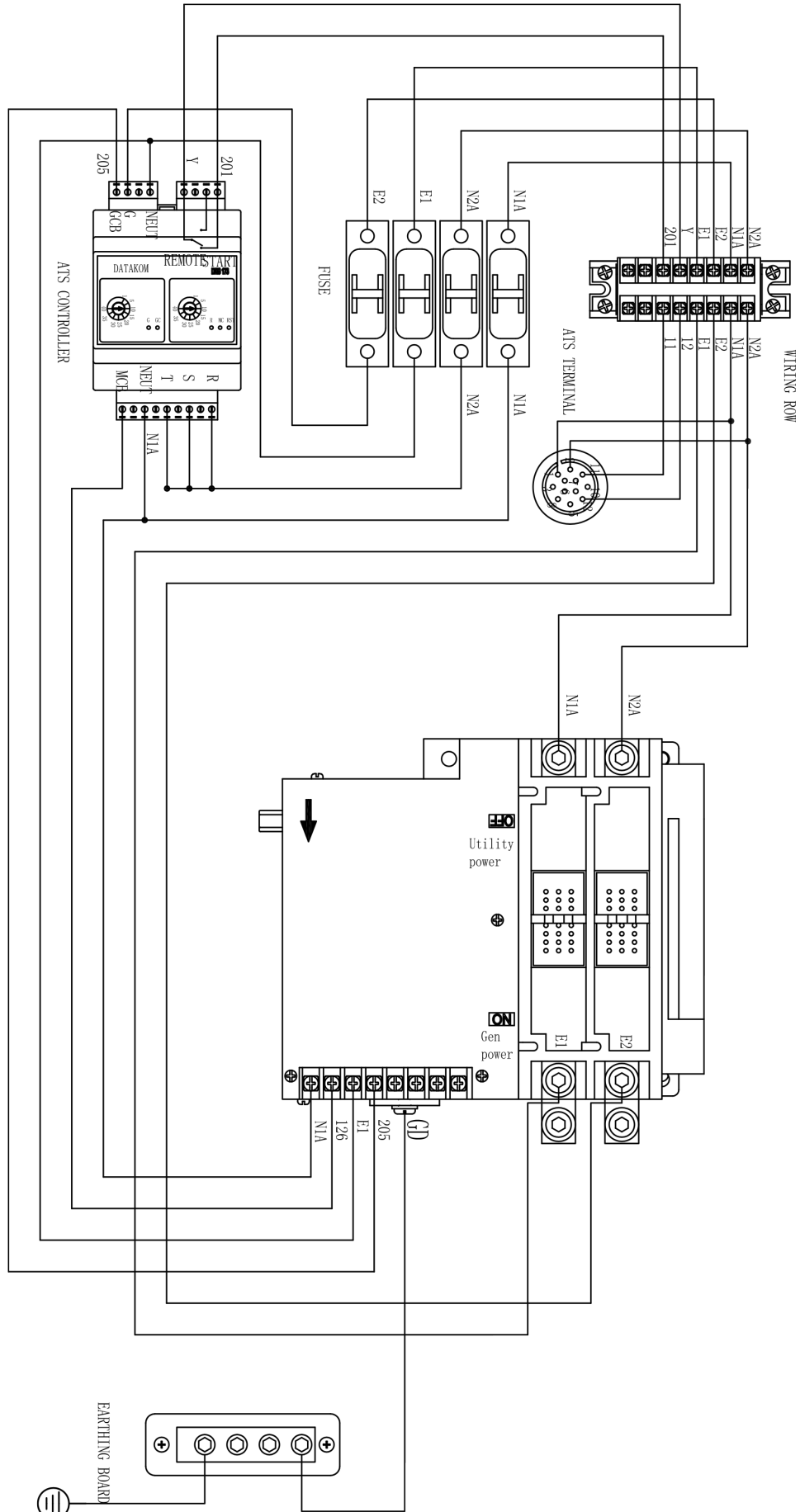

ATS Three Phase Connection Diagram

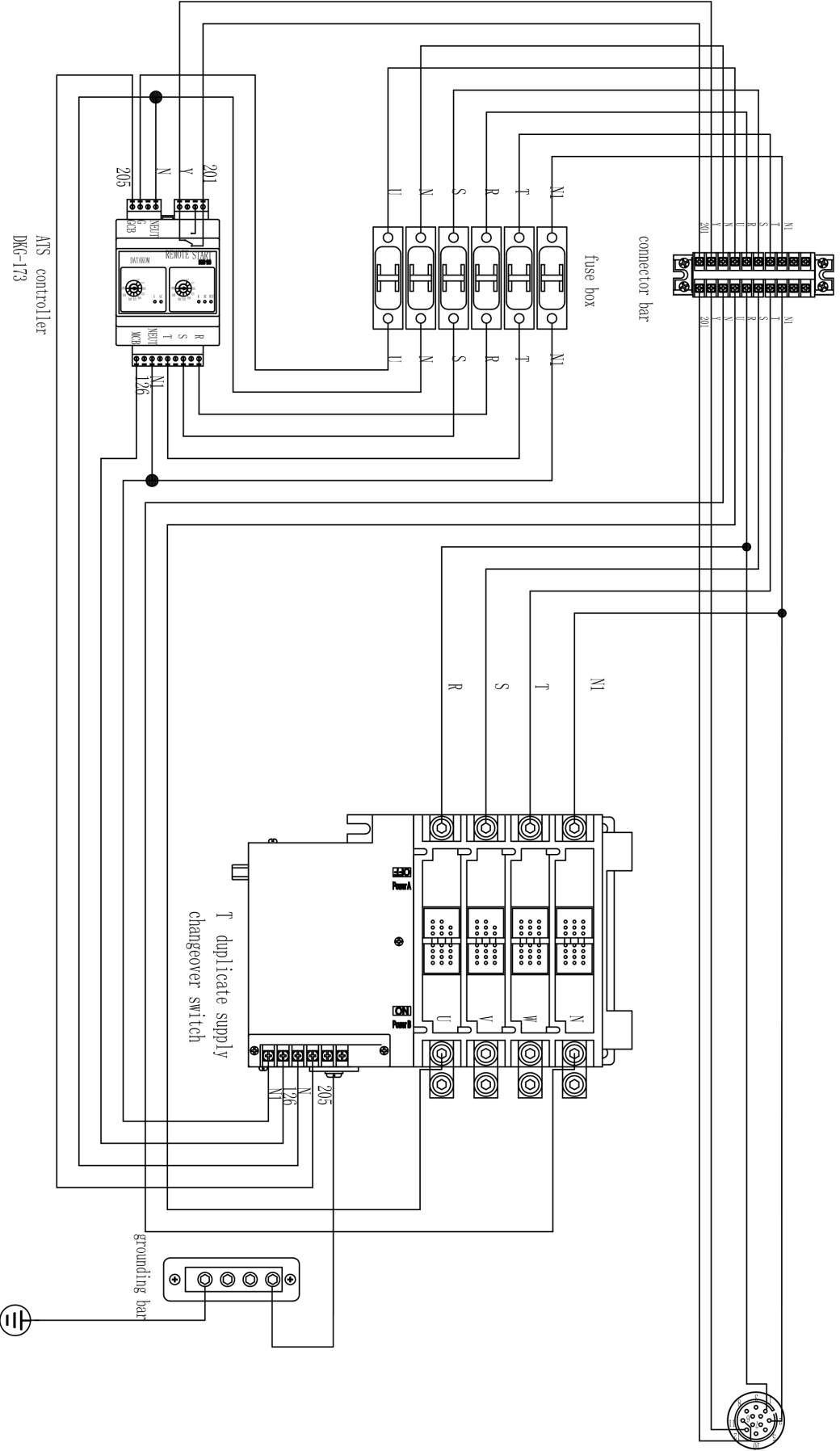

ATS Three Phase Exploded Diagram

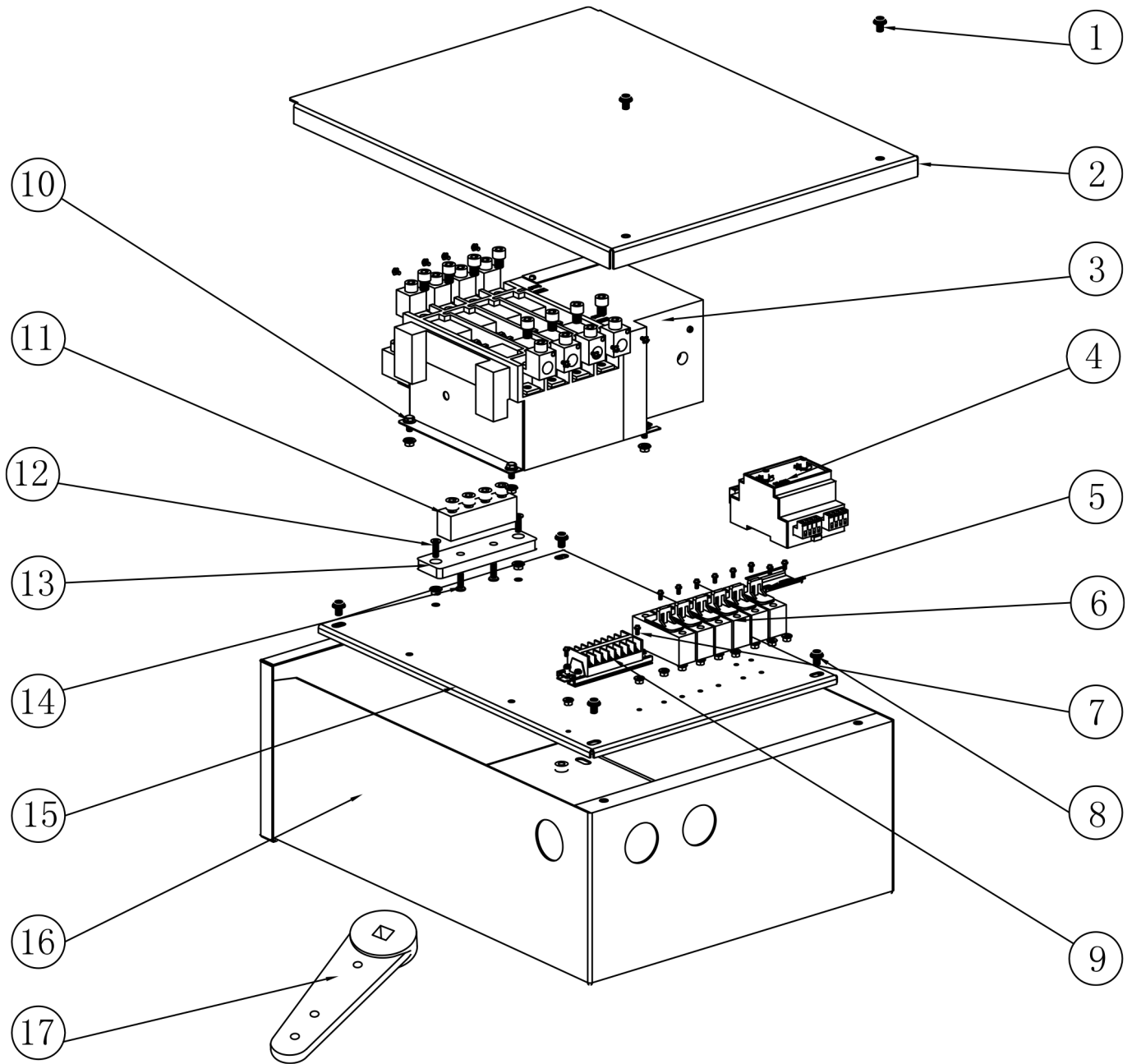

ATS Single Phase Exploded Diagram

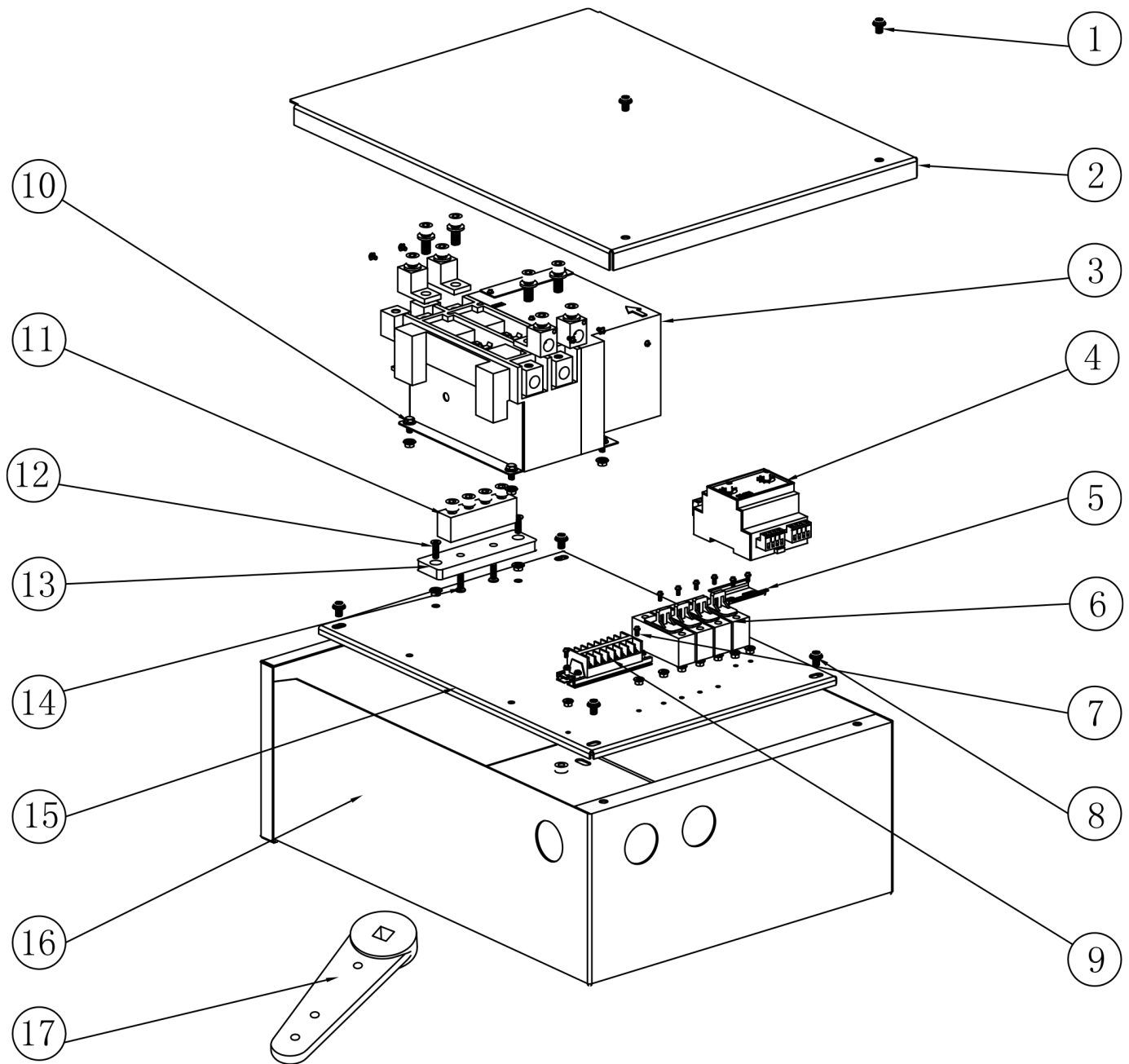

ATS Single Phase Installation Diagram

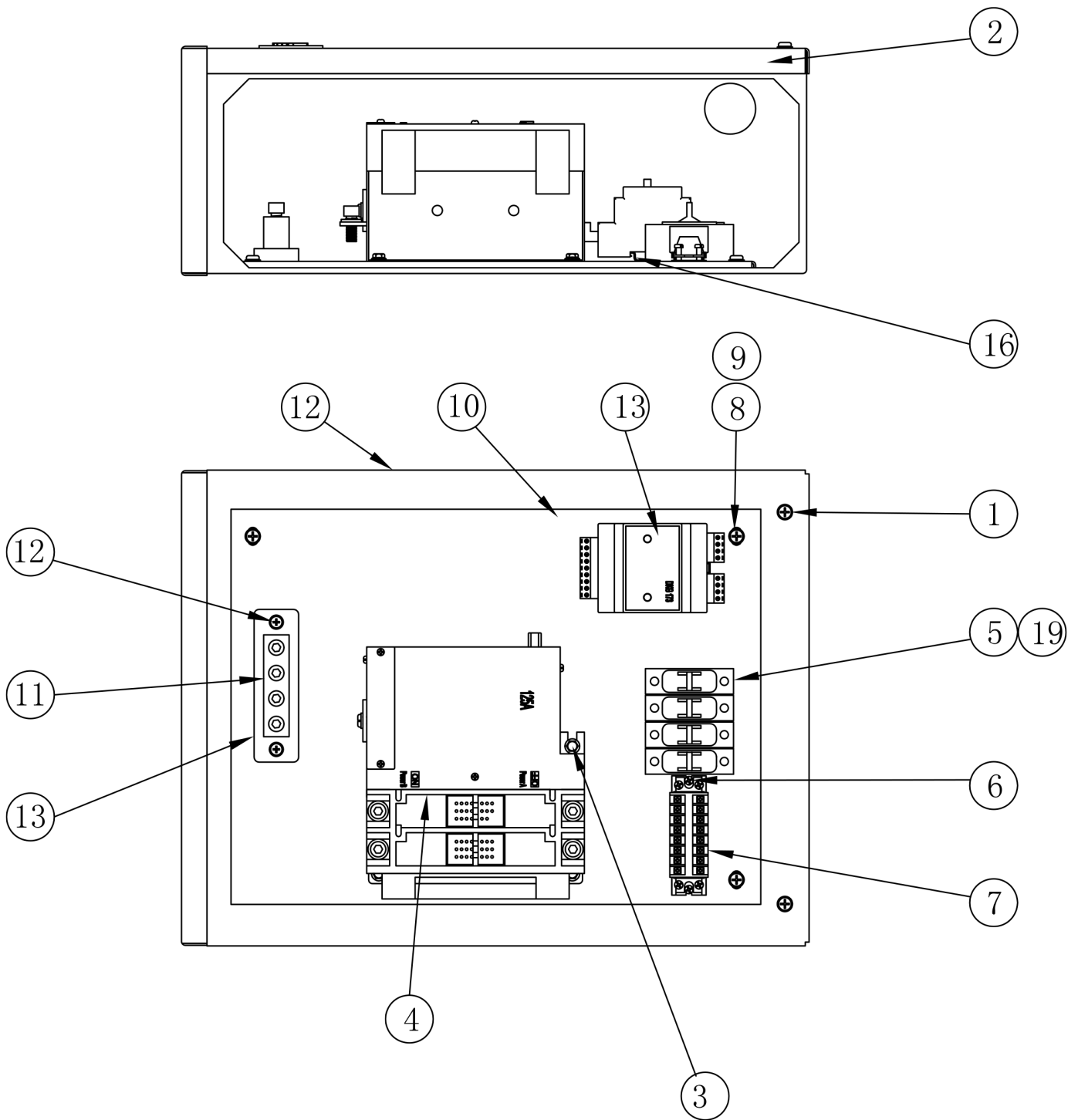

ATS Three Phase Installation Diagram

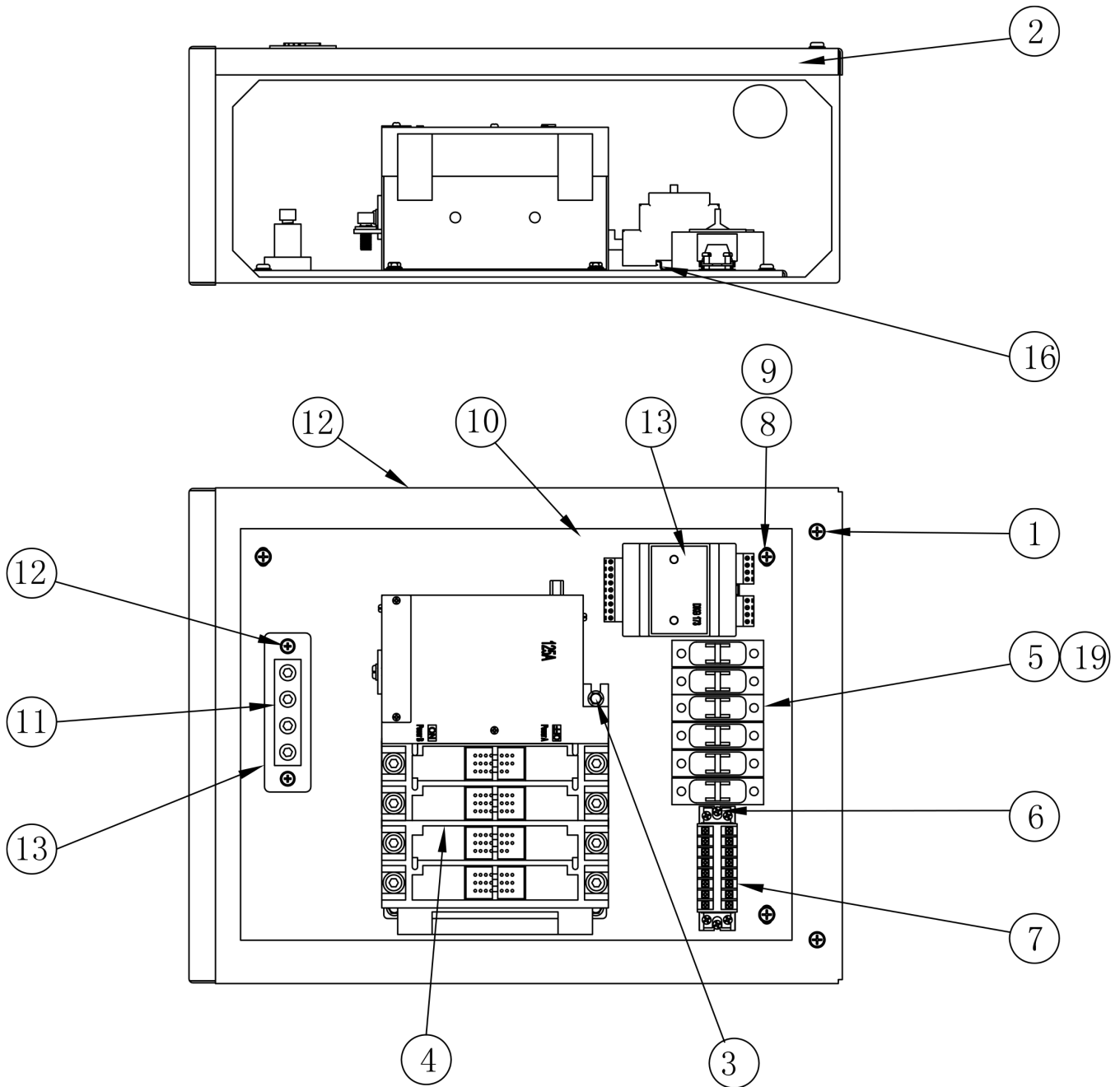

Parts List

ATS Single Phase Parts List			
No.	Parts Name	Quantity	Model
1	Round Cross-Head Screw	2	M6×1.0×10
2	ATS Box Upper Cover	1	
3	Hexagon flange bolts	3	M5×1.0×12
4	Transfer Switch	1	MCQ2-200A 2P
5	Fuse Base	4	OP530
6	Round Cross-Head Screw	8	M4×0.75×8
7	Connector Bar	2	15A-4P
8	Round Cross-Head Screw	4	M5×1.0×10
9	Gasket	4	M5×1.0×12
10	ATS Box Fixing Plate	1	
11	Nut	5	M5×1.0
12	ATS Box	1	
13	ATS Controller	1	DKG-173
14	Flat Cross-Head Screw	2	M5×1.0×12
15	Grounding Bar	1	
16	Mounting Bar	1	
17	Nut	8	M4×0.75
18	ATS Box Side Cover	1	
19	Fuse	4	10A
20	Handle Shank	1	

ATS Three Phase Parts List			
No.	Parts Name	Quantity	Model
1	Round Cross-Head Screw	2	M6×1.0×10
2	ATS Box Upper Cover	1	
3	Hexagon flange bolts	3	M5×1.0×12
4	Transfer Switch	1	MCQ2-200A 4P
5	Fuse Base	6	OP530
6	Round Cross-Head Screw	10	M4×0.75×8
7	Connector Bar	2	15A-4P
8	Round Cross-Head Screw	4	M5×1.0×10
9	Gasket	4	M5×1.0×12
10	ATS Box Fixing Plate	1	
11	Nut	5	M5×1.0
12	ATS Box	1	
13	ATS Controller	1	DKG-173
14	Flat Cross-Head Screw	2	M5×1.0×12
15	Grounding Bar	1	
16	Mounting Bar	1	
17	Nut	10	M4×0.75
18	ATS Box Side Cover	1	
19	Fuse	6	10A
20	Handle Shank	1	

ATS Control Box Installation Hole Diagram

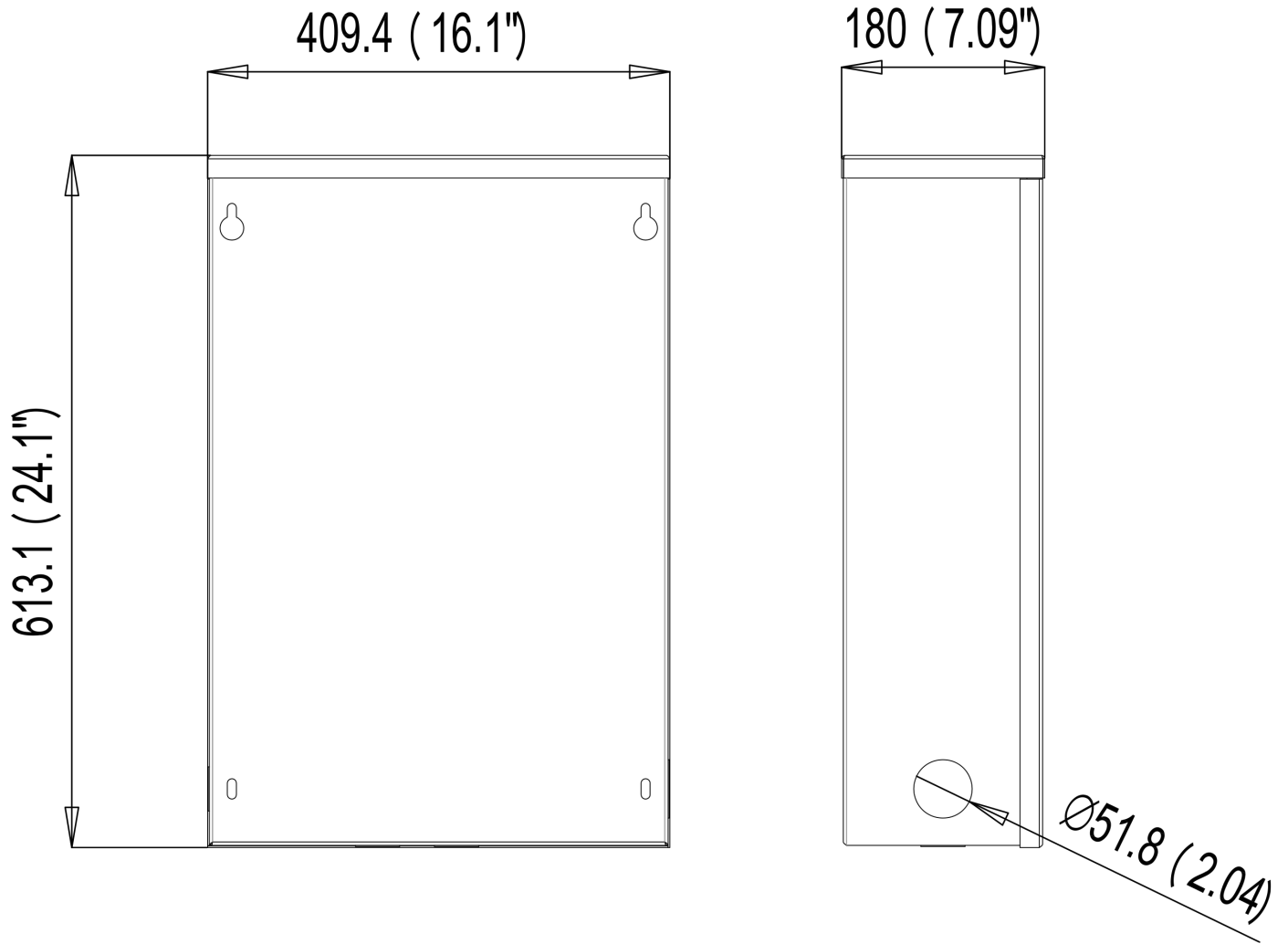

ATS Single Phase Connection Schematics

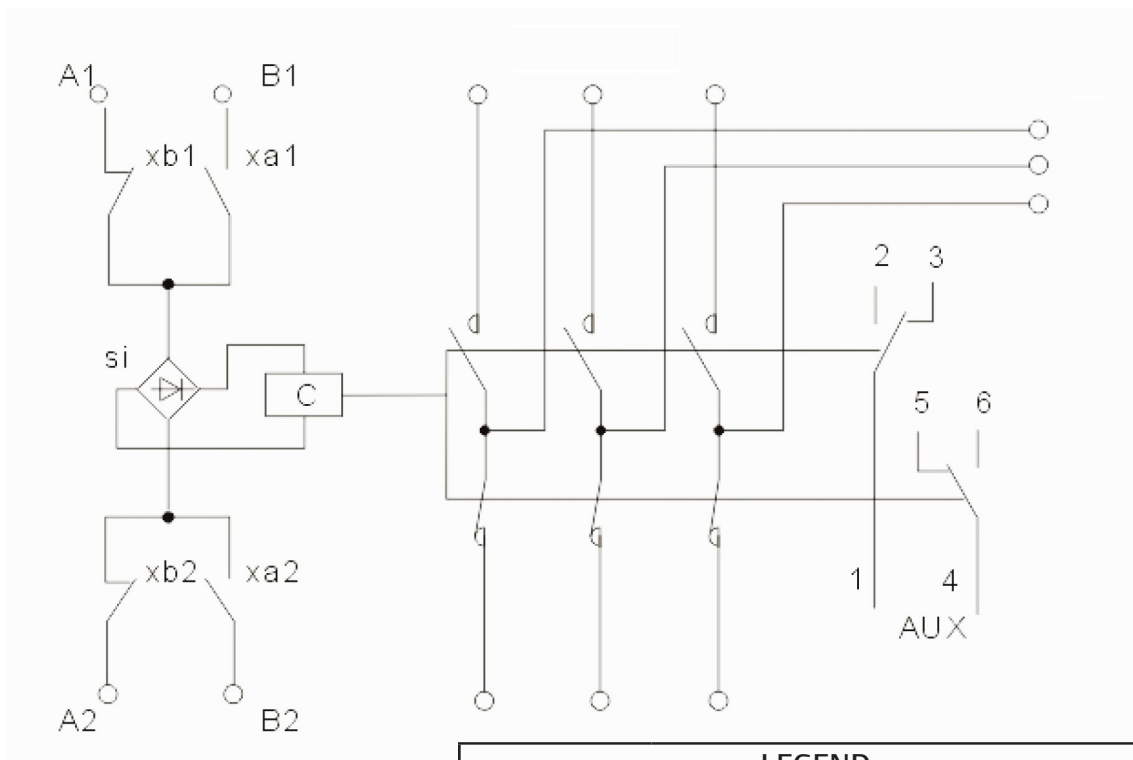
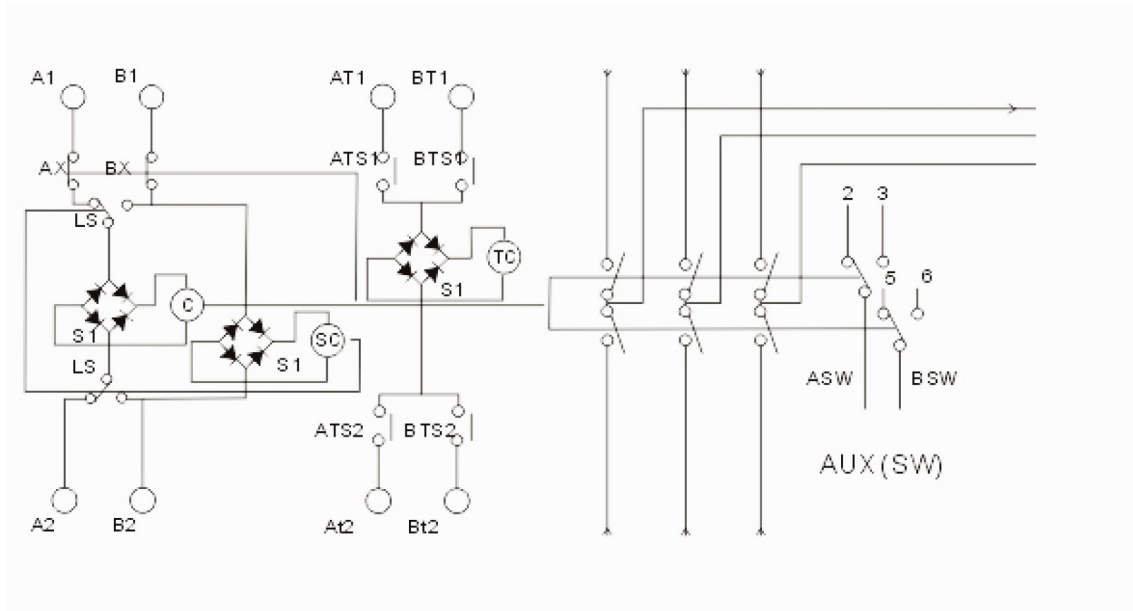

Note:
All contacts shown with transfer switch in utility position.

LEGEND	
ATS	Transfer Switch Contactor
C1	Solenoid Coil (utility closing)
C2	Solenoid Coil (standby closing)
TR	Relay Transfer
TB	Terminal Strip (customer connection)
XA1, XB1	Limit Switches Actuator
F1, F2, F3, F4	Fuse, 5a
VR1, VR2	Varistor
NB	Neutral Block

ATS Three Phase Connection Schematics

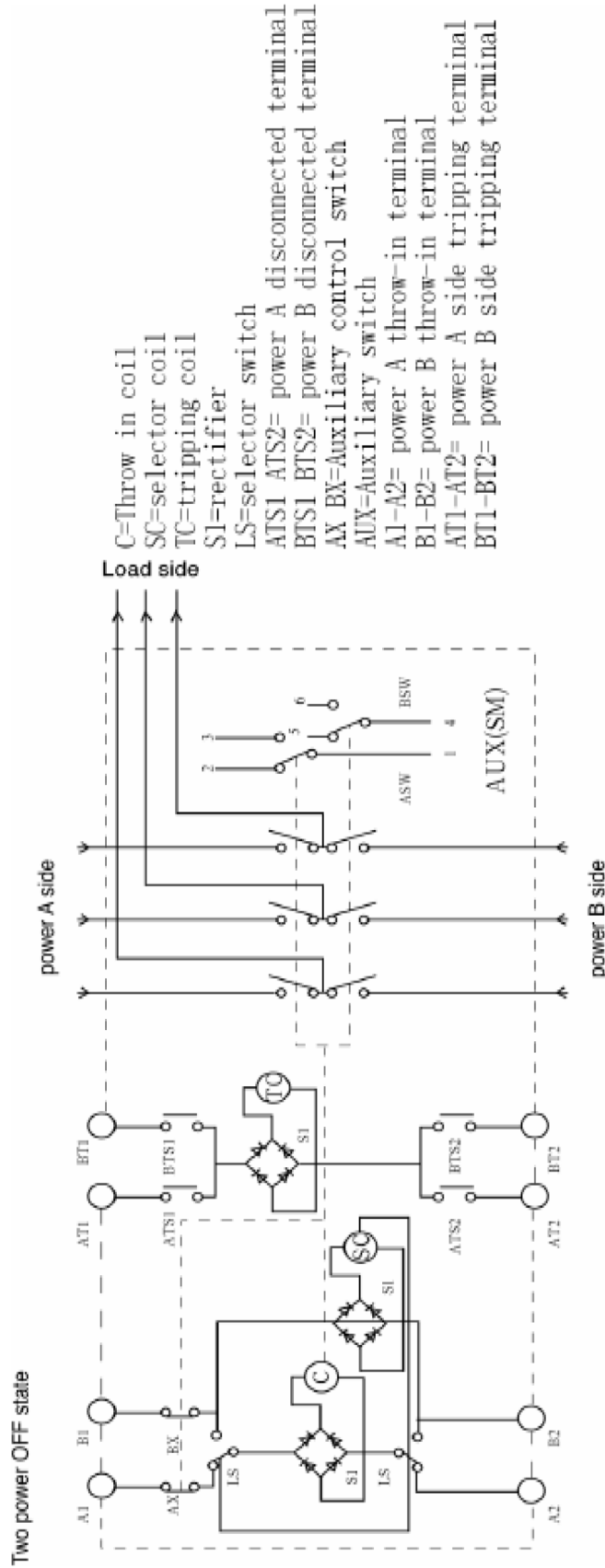

ATS Three Phase Connection Diagram

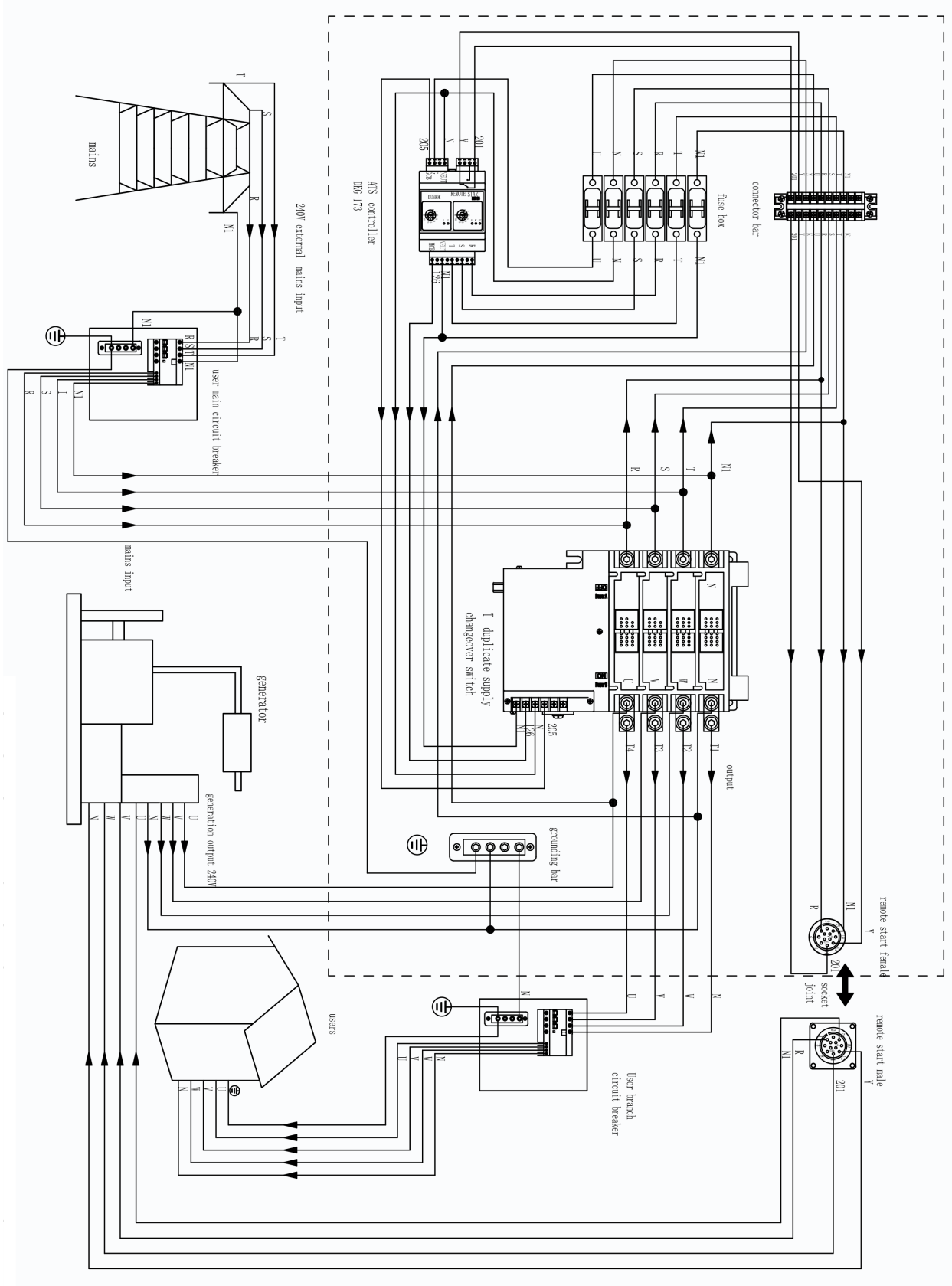

ATS Single Phase Connection Diagram

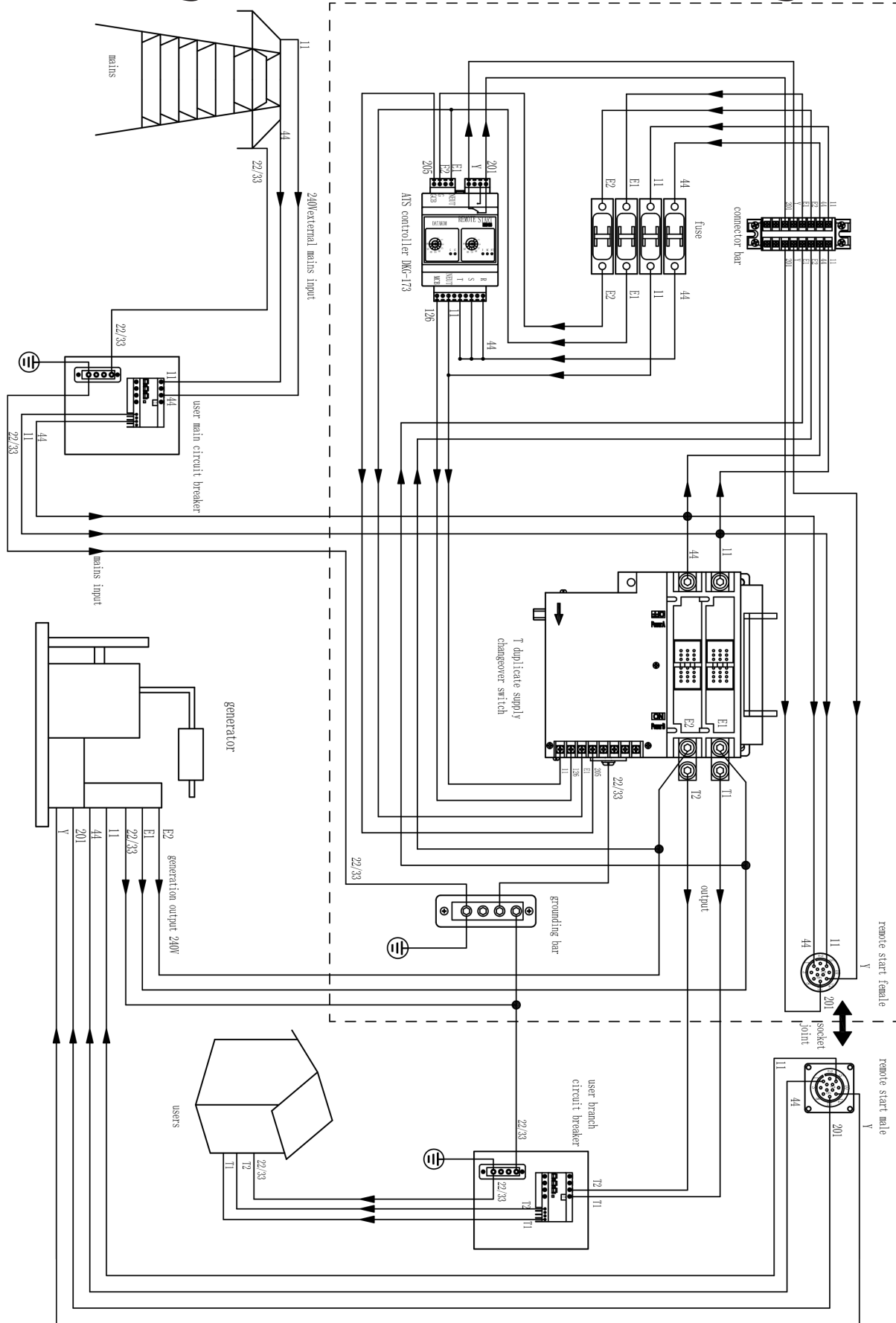

Maintenance & Service

The Free Warranty is 18 months from the date of delivery. The manufacturer will provide free repair services for problems caused by product quality within this free warranty. Paid repair or replacement services are available after the free warranty period.

Damage caused by the following reasons will be charged even if the products you purchased are still in the free warranty period:

1. Misconnection of wires, private disassembly & assembly or repair
2. Exceed the standards, such as operations out of the current limits or over-testing over insulation voltage, etc.
3. External injury or damage due to drop or impact.
4. Natural hazards or abnormal disasters, such as earthquake, fire, thunder strike and abnormal voltage, etc.

Note:

Do not install in environments where there may be explosive gases, or explosion will happen.

Do not install in humid environments.

Do not install in places where its external magnetic field is 5 times larger than the earth's magnetic field, or the dual power can not work properly.

Do not install in places where the vibration is larger than 5 grams.

Do not install in places where metal is vulnerable to gas corrosion and insulation material can be easily broken.

EQUIPSOURCE, LLC D/B/A LIFAN POWER USA
2205 Industrial Park Road
Van Buren, Arkansas 72956

(866) 471-7464
Fax: (479) 471-7466

www.lifanpowerusa.com



Ingersoll Rand (NYSE:IR) advances the quality of life by creating comfortable, sustainable and efficient environments. Our people and our family of brands—including Club Car®, Ingersoll Rand®, Thermo King® and Trane®—work together to enhance the quality and comfort of air in homes and buildings; transport and protect food and perishables; and increase industrial productivity and efficiency. We are a \$13 billion global business committed to a world of sustainable progress and enduring results.



ingersollrand.com

Free Manuals Download Website

<http://myh66.com>

<http://usermanuals.us>

<http://www.somanuals.com>

<http://www.4manuals.cc>

<http://www.manual-lib.com>

<http://www.404manual.com>

<http://www.luxmanual.com>

<http://aubethermostatmanual.com>

Golf course search by state

<http://golfingnear.com>

Email search by domain

<http://emailbydomain.com>

Auto manuals search

<http://auto.somanuals.com>

TV manuals search

<http://tv.somanuals.com>