

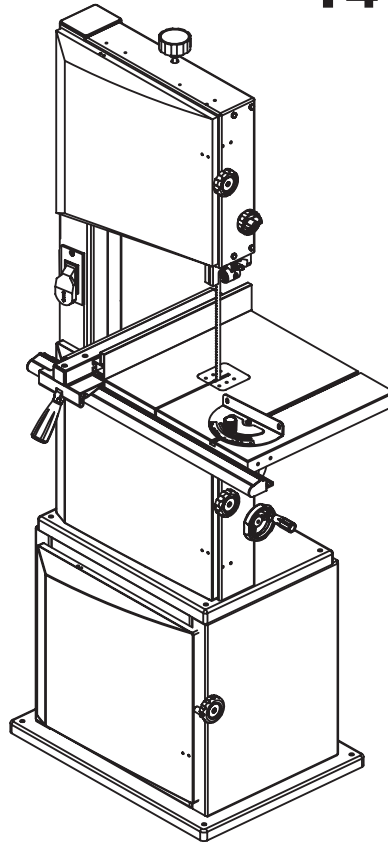

OPERATOR'S MANUAL

14" Band Saw

Model # 3914



IMPORTANT:

Your new tool has been engineered and manufactured to WEN's highest standards for dependability, ease of operation, and operator safety. When properly cared for, this product will supply you years of rugged, trouble-free performance.

Pay close attention to the rules for safe operation, warnings, and cautions. If you use your tool properly and for its intended purpose, you will enjoy years of safe, reliable service.



Need help? Contact us!

Have product questions? Need technical support?

Please feel free to contact us at:

 **800-232-1195** (M-F 8AM-5PM CST)

 **techsupport@wenproducts.com**

 **WENPRODUCTS.COM**

Table of Contents

Technical data	2
General safety rules.....	4
Specific safety rules for band saws.....	6
Electrical information	7
Know your band saw	9
Assembly and adjustments.....	10
Operation.....	20
Maintenance.....	21
Exploded view and parts list.....	22
Warranty	27

Technical Data

14inch Band Saw

Model:	3914
Motor:	120 V, 60 Hz, 9.5 A
Motor speed:	1725 RPM (no load)
Blade speed:	1445/3150 FPM
Blade length:	100-3/4"
Blade width range:	1/8" to 3/4"
Depth of throat at 90°:	13-1/2"
Maximum depth of cut at 90°:	9"
Maximum depth of cut at 45°:	6"
Table size:	15-3/4" x 21-1/2"
Table tilt:	0° to 45°
Wheel diameter:	13-3/4"
Overall dimensions:	33" x 20" x 68"
Dust port:	4" (dia.)
Net Weight:	189 lbs

General safety rules

Safety is a combination of common sense, staying alert and knowing how your band saw works. **SAVE THESE SAFETY INSTRUCTIONS.**



WARNING: To avoid mistakes that could cause serious injury, do not plug in the band saw until the following steps have been read and understood.

1. **READ** and become familiar with this entire instruction manual. **LEARN** the tool's applications, limitations, and possible hazards.
2. **AVOID DANGEROUS CONDITIONS.** Do not use power tools in wet/damp areas or expose them to rain. Keep work areas well lit.
3. **DO NOT** use power tools in the presence of flammable liquids or gases.
4. **ALWAYS** keep your work area clean, uncluttered, and well lit. **DO NOT** work on floor surfaces that are slippery with sawdust or wax.
5. **KEEP BYSTANDERS AT A SAFE DISTANCE** from the work area, especially when the tool is operating. **NEVER** allow children or pets near the tool.
6. **DO NOT FORCE THE TOOL** to do a job for which it was not designed.
7. **DRESS FOR SAFETY.** Do not wear loose clothing, gloves, neckties, or jewelry (rings, watches, etc.) when operating the tool. Inappropriate clothing and items can get caught in moving parts and draw you in. **ALWAYS** wear non-slip footwear and tie back long hair.
8. **WEAR A FACE MASK OR DUST MASK** as the sawing operation produces dust.



WARNING: Dust generated from certain materials can be hazardous to your health. Always operate the band saw in a well-ventilated area and provide for proper dust removal. Use dust collection systems whenever possible.

9. **AL**power cord plug from the electrical outlet whaking adjustments, changing parts, cleaning, or working on the tool.
10. **KEEP GUARDS IN PLACE AND IN WORKING ORDER.**
11. **AVOID ACCIDENTAL START-UPS.** Make sure the power switch is in the OFF position before plugging in the power cord.
12. **REMOVE ADJUSTMENT TOOLS.** Always make sure all adjustment tools are removed from the saw before turning it on.

13. NEVER LEAVE A RUNNING TOOL UNATTENDED. Turn the power switch to OFF. Do not leave the tool until it has come to a complete stop.
14. NEVER STAND ON A TOOL. Serious injury could result if the tool tips or is accidentally hit. DO NOT store anything above or near the tool.
15. DO NOT OVERREACH. Keep proper footing and balance at all times. Wear oil-resistant rubber-soled footwear. Keep the floor clear of oil, scrap, and other debris.
16. MAINTAIN TOOLS PROPERLY. ALWAYS keep tools clean and in good working order. Follow instructions for lubricating and changing accessories.
17. CHECK FOR DAMAGED PARTS. Check for alignment of moving parts, jamming, breakage, improper mounting, or any other conditions that may affect the tool's operation. Any part that is damaged should be properly repaired or replaced before use.
18. MAKE THE WORKSHOP CHILDPROOF. Use padlocks and master switches and ALWAYS remove starter keys.
19. DO NOT operate the tool if you are under the influence of drugs, alcohol, or medication that could affect your ability to use the tool properly.
20. USE SAFETY GOGGLES AT ALL TIMES that comply with ANSI Z87.1. Normal safety glasses only have impact resistant lenses and are not designed for safety. Wear a face or dust mask when working in a dusty environment. Use ear protection such as plugs or muffs during extended periods of operation.

Specific safety rules for band saws

1. To avoid injury from unexpected movement, make sure the saw is on a firm, level surface and secured properly to prevent rocking. Make sure there is adequate space for operations. Bolt the saw to a support surface to prevent slipping or sliding during operation.
2. Turn off and unplug the saw before moving it.
3. Use the correct size and style of blade.
4. Make sure the blade teeth point down and toward the table.
5. Blade guide, supports, bearings, and blade tension must be properly adjusted to avoid accidental blade contact and to minimize blade breakage. To maximize blade support, always adjust the upper blade guide and blade guard so that it barely clears the workpiece.
6. Table TILT lock handle should be tight.
7. Use extra caution with very large, very small, or awkwardly shaped workpieces.
8. Use extra supports to prevent workpieces from sliding off the tabletop.
9. Workpieces should be secured so they don't twist, rock, or slip while being cut.
10. Plan intricate or small work carefully to avoid pinching the blade. Avoid awkward operations and hand positions to prevent accidental contact with the blade.
11. Small pieces should be secured with clamps or fixtures. Do not hold small pieces with your hand since your fingers may go under the blade guard.
12. Support round work properly (use a V block or press it against the miter gauge) to prevent the piece from rolling and the blade from biting.
13. Cut only one workpiece at a time. Make sure the table is clear of everything except the workpiece and its guides before turning on the saw.
14. Always watch the saw run before each use. If there is excessive vibration or unusual noise, stop immediately. Turn the saw off. Unplug it immediately. Do not start the saw again until the problem has been located and corrected.
15. To free any jammed material, turn the switch off. Remove the switch key and unplug the saw. Wait for all moving parts to stop before removing the jammed material.

16. Don't leave the work area until all moving parts have stopped. Shut off the power to master switches. Remove the switch key from the band saw and store it in a safe place away from children. Childproof the workshop!

Electrical information

Grounding Instructions

IN THE EVENT OF A MALFUNCTION OR BREAKDOWN, grounding provides the path of least resistance for electric current and reduces the risk of electric shock. This tool is equipped with an electric cord that has an equipment-grounding conductor and a grounding plug. The plug **MUST** be plugged into a matching outlet that is properly installed and grounded in accordance with ALL local codes and ordinances.

DO NOT MODIFY THE PLUG PROVIDED. If it does not fit the outlet, have the proper outlet installed by an electrician.

IMPROPER CONNECTION of the equipment grounding conductor can result in electric shock. The conductor with the green insulation (with or without yellow stripes) is the equipment-grounding conductor. **DO NOT** connect the equipment-grounding conductor to a live terminal if repair/replacement of the electric cord/plug is necessary.

CHECK with a licensed electrician or service personnel if you do not completely understand the grounding instructions or if the tool is properly grounded.

USE ONLY THREE-WIRE EXTENSION CORDS with three-prong plugs and three-prong outlets as shown in Fig. A. Repair or replace a damaged or worn cord immediately.

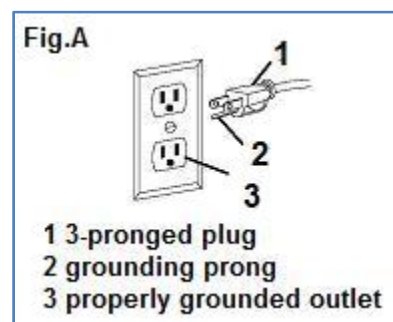

CAUTION: In all cases, make certain the outlet in question is properly grounded. If you are not sure, have a licensed electrician check the outlet.



WARNING: This saw is for indoor use only. Do not expose to rain or use in damp locations.

Guidelines for Using Extension Cords

Make sure your extension cord is in good condition. When using an extension cord, be sure to use one heavy enough to carry the current your product will draw. An undersized cord will cause a drop in line voltage resulting in loss of power and overheating. The table below shows the correct size to be used according to cord length and nameplate ampere rating. When in doubt, use a smaller-numbered gauge (the smaller the gauge number, the heavier the cord).

Minimum Gauge for Extension Cords (AWG) (when using 120 V only)

Total Length of Cord in feet			
25 Feet	50 Feet	100 Feet	150 Feet
18 Gauge	16 Gauge	14 Gauge	12 Gauge

Be sure your extension cord is properly wired and in good condition. Always replace a damaged extension cord or have it repaired by a qualified person before using it.

Protect your extension cords from sharp objects, excessive heat and damp or wet areas. Use a separate electrical circuit for your tools. This circuit must not be less than a #12 wire and should be protected with a 15 A time-delayed fuse. Before connecting the motor to the power line, make sure the switch is in the OFF position and the electric current is rated the same as the current stamped on the motor nameplate. Running at a lower voltage will damage the motor.



WARNING: This tool must be grounded while in use to protect the operator from electrical shock.

Know your band saw

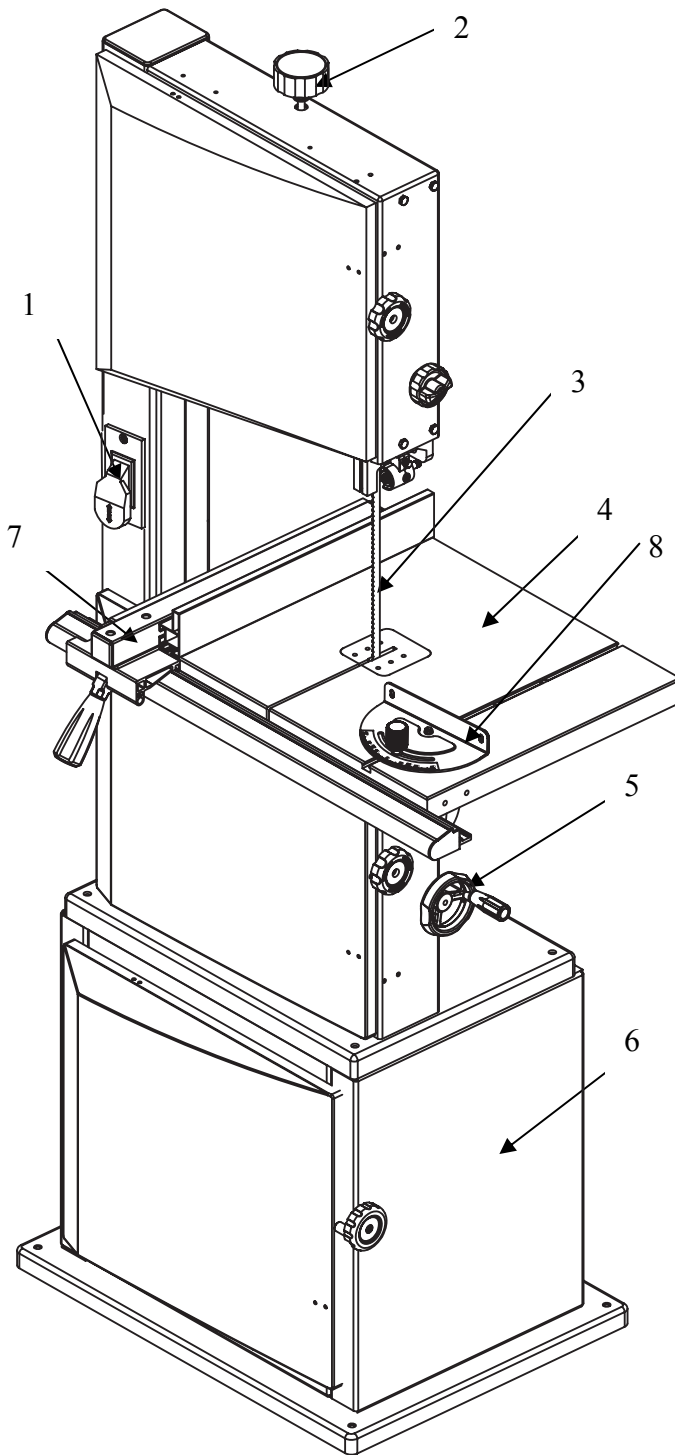

- 1 Switch
- 2 Blade-tension-adjusting knob
- 3 Blade
- 4 Work table
- 5 Blade tension wheel
- 6 Storage
- 7 Rip fence
- 8 Miter gauge



WARNING: For your own safety, read the instruction manual before operating the band saw.

1. Wear eye protection.
2. Do not wear gloves, neckties, jewelry, or loose clothing.
3. Make sure the saw is properly secured on a firm, level surface.
4. Use only the recommended accessories.
5. Use extra caution with very large, very small, or awkwardly shaped workpieces.
6. Keep hands away from the blade at all times to prevent accidental injury.

Assembly and adjustments

Unpacking

Carefully unpack the band saw and all its parts. Compare against the list below. Do not discard the carton or any packaging until the band saw is completely assembled.



WARNING: If any part is missing or damaged, do not plug in the band saw until the missing or damaged part is replaced.

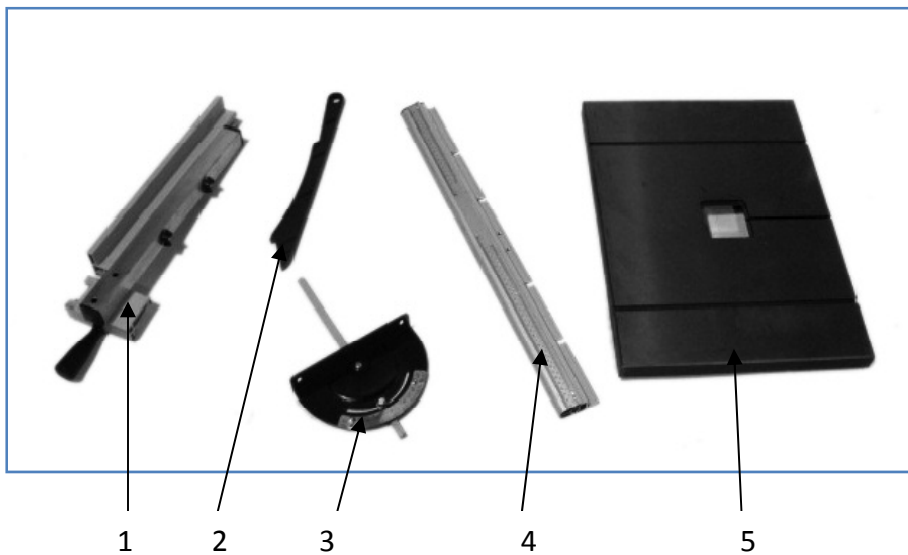

- 1 Rip fence assembly
- 2 Push stick
- 3 Miter gauge
- 4 Guide rail
- 5 Work table

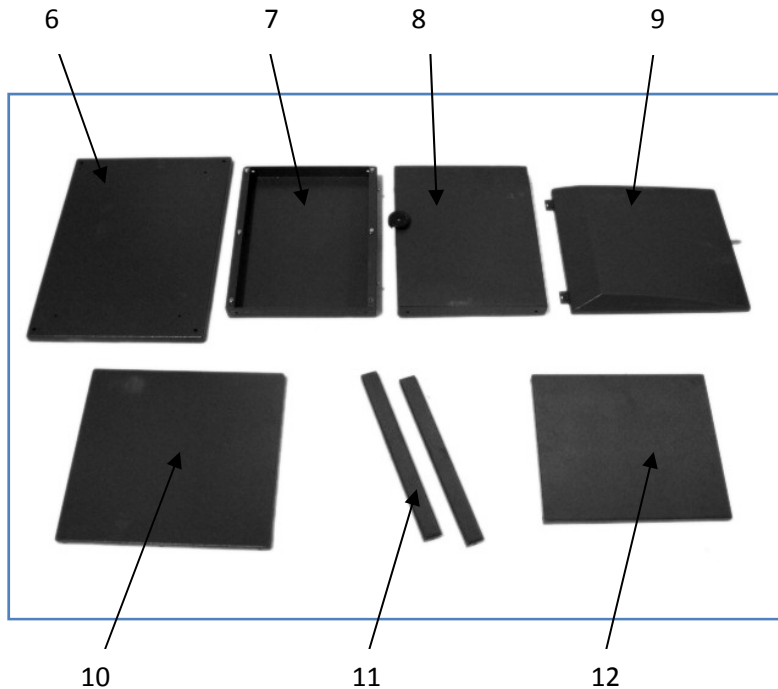

- 6 Base
- 7 Left panel
- 8 Right panel
- 9 Door assembly
- 10 Rear panel
- 11 Brace (2)
- 12 Shelf

Parts bag includes: Handwheel Assembly (1), WingKnob Screw (4), M6 x 16 Hex Head Bolt (4), M6 FlatWasher (4), Push Stick Hook w/nut (1), Hex Wrench (1) and Open End Wrench (1).

Hardware bag includes: M8 Flat Washer (4), M6 x 16Hex Head Bolt (12), M6 x 16 Socket Head Bolt (4), M6 x40 Flat Head Screw (4), M6 Flat Washer (24), M6 HexNut (8), M5 x 6 Pan Head Screw (2) and M5 FlatWasher (2).

IMPORTANT: Table is coated with a protectant. To ensure proper fit and operation, remove coating. Coating is easily removed with mild solvents, such as mineral spirits, and a soft cloth. Avoid getting solution on paint or any of the rubber or plastic parts. Solvents may deteriorate these finishes. Use soap and water on paint, plastic or rubber components. After cleaning, cover all exposed metal surfaces with a light coating of oil. Paste wax is recommended for tabletop.



WARNING: Never use highly volatile solvents. Non-flammable solvents are recommended to avoid possible fire hazard.

Assembly

CAUTION: Do not attempt assembly if parts are missing. Use this manual to order replacement parts.

WARNING: To avoid injury, do not attempt to run or use this machine until all parts are assembled and working properly.

Assembly stand

Note: Hand-tighten all hardware during assembly. Do not completely tighten hardware until assembly is complete.

Refer to Exploded View and Parts List, Page 26.

1. Place base (Item 6) on flat surface. Attach right and left panels (Item 1 and 5) to base using four socket head bolts, washers and hex nuts (Item 14, 10 and 13).
2. Attach rear panel (Item 3) to the side panels using four hex head bolts and flat washers (Item 10 and 11).
3. Attach the two braces (Item 2) to the top front and bottom front of the side panels using four hex head bolts and flat washers.
4. Attach the shelf (Item 4) to the center of the side panels using four hex head bolts and flat washers.
5. Attach the door assembly (Item 7) to the left panel using two pan head screws and flat washers (Item 8 and 9).
6. Secure all hardware.
7. Place band saw on top of stand and secure in position using four flat head screws, washers, and hex nuts (Item 12, 10 and 13).

Attach table to trunnion

1. Place the table on the trunnion. Use caution when passing the saw blade through the slot of the table (See Figure 1).
2. Locate four M6 x 16 hex bolts and four M6 flat washers from the bag of loose parts. Mount the table to the upper table trunnion and install a bolt with a washer in each hole. Tighten with adjustable wrench.

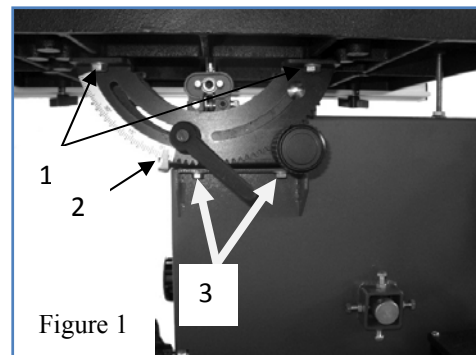

- 1- Bolt Attach Table
- 2- Indicator
- 3- Adjusting Bolts

Centering the table

1. Loosen the hex bolts mounting the trunnion to the saw frame (see Figure 1).
2. Move the table sideways as required, until the saw blade runs through the center of the table insert.
3. Re-tighten hex bolts for trunnion and recheck the saw blade position.

Setting table square to saw blade

Refer to Figures 1 and 2.

Loosen the handle on the table trunnion and place a suitably sized square against the saw blade. If the table requires adjustment, proceed as follows:

1. Using a wrench, loosen the hex nut (See Figure 2).
2. Place the wrench on the hex bolt and adjust until the table is square to the saw blade.
3. Tighten the hex nut and recheck the saw blade and the table for squareness.
4. Lock the table into position and check that the indicator reads zero degrees on the scale of the trunnion.

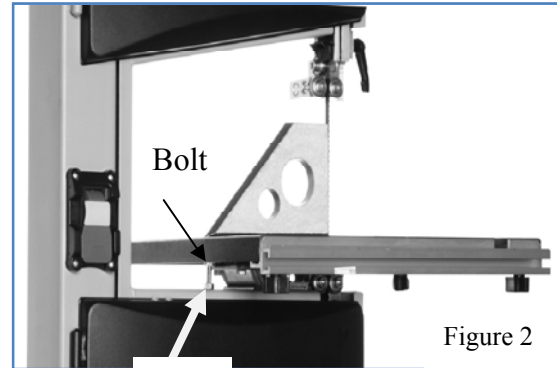

If necessary, loosen the screw securing the indicator and reset it to give zero degree reading (See Figure 1).

Attach guide rail

Fasten the guide rail to the table with four wing knob screws and M8 washers (See Figure 3).

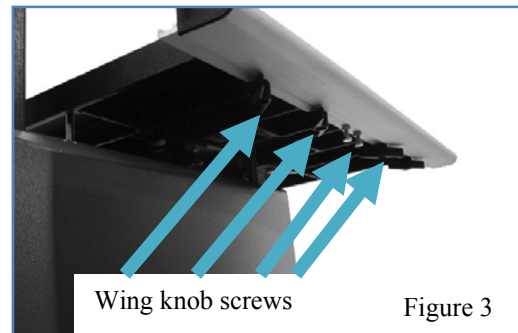

Install rip fence

Lay the rip fence onto the guide rail. Adjust the rip fence parallel to the saw blade. Tighten rip fence handle by pressing downward (See Figure 4).

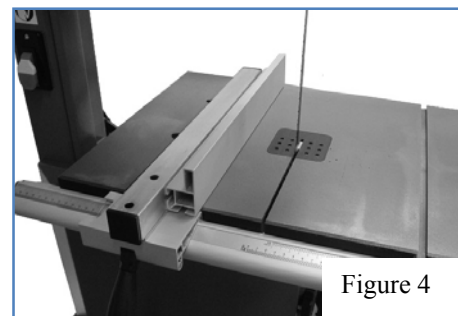

Attach pushstick storage hook

Refer to Figure 5.

1. Thread hex nut completely up to unthreaded portion of hook.
2. Thread the hook into the saw's frame several turns.
3. Tighten hex nut against saw frame.
4. Store pushstick on hook when not in use.

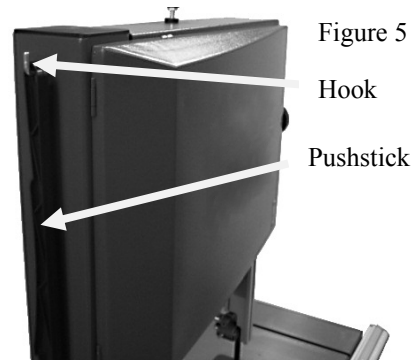

Attach drive belt tension handwheel

Refer to figure 6.

1. Place handwheel assembly onto shaft.
2. Secure in position with setscrew.

Stabilize machine

The machine should be bolted to floor, bench, or worktable to ensure sufficient upright stability. For this purpose 8mm holes are provided in the machine's base. Mounting hardware not provided.

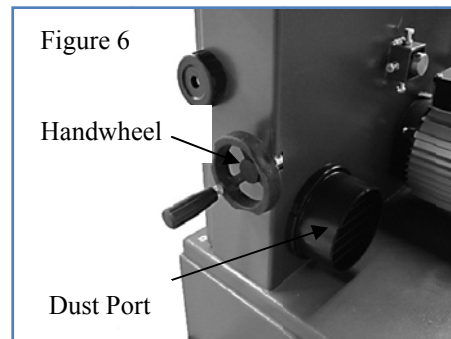

Use suitable dust collector

The band saw has a 4" dust port included (See Figure 6). It is recommended to connect the band saw to a suitable dust collector when in use.

Adjustments

The blade tracking, tension and blade guides have been properly adjusted at the factory. However, the adjustments may change while the saw is in transit. It is recommended to verify these adjustments before operating the saw.

Changing and adjusting the saw blade

This band saw is factory-equipped with a general-purpose, woodcutting blade; the saw blade is set prior to delivery.

To change the saw blade, follow the procedure below:



WARNING: To avoid injury from unexpected starting, whenever changing the saw blade or carrying out adjustments, switch the band saw off and remove the power cord from the main outlet. To avoid injury to hands when handling the saw blade, wear gloves whenever necessary.

1. Remove the rip fence and the guide rail from the table.
2. Open the upper and lower doors by turning the door locking knobs.
3. Loosen the tracking Lock Nut (See figure 7).
4. Loosen the blade tension by turning the blade-tension knob on the top of the upper-wheel housing counterclockwise until the saw blade has slackened (viewed from above) or turn quick release lever to the right. See Figure 7.
5. Remove the saw blade from the upper and lower wheels.
6. When fitting the new saw blade ensure the blade teeth are pointing downwards and towards you at the position where the saw blade passes through the table.
7. Re-tension the new saw blade and check the saw blade tracking by turning the upper wheel by hand. The saw blade should run in the center of the band saw wheels.
8. Tighten the tracking lock nut.
9. If you need to adjust the tracking of the saw blade, follow the procedures for TRACKING THE SAW BLADE.
10. Replace the rip fence and the guide rail onto the table.
11. Close the upper and lower doors by turning the door locking knobs before reconnecting the power supply.

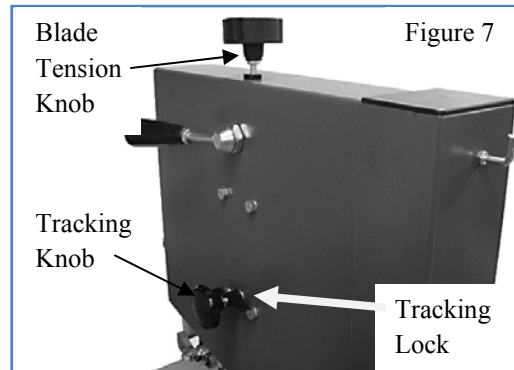

Tracking the saw blade

Set the tracking of the saw blade before setting the blade guides.

Once the saw blade is installed and tensioned, track the saw blade by adjusting the tracking knob by hand (See Figure 7). The saw blade should run in the center of the band saw wheels. When the correct adjustment is achieved lock the tracking knob with the locking nut.

Setting the cutting height

1. The upper blade guide should be set as close as is practically necessary against the workpiece.
2. To adjust this height, loosen the locking knob in the center of the adjusting knob (See Figure 8).
3. Set the blade guide to the required height by turning the guidepost-adjusting knob.
4. Tighten locking knob after setting.

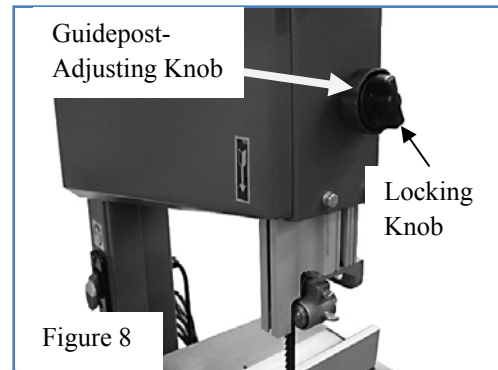

Adjusting the blade guides

NOTE: Upper and lower blade guides are adjusted in the same manner. See Figures 9 and 10.

1. To adjust the upper blade guides, first position the right and left roller guides relative to the blade by loosening set screw (A) and moving the guide carrier until both roller guides are approximately 1/16" behind the gullets of the saw blade. Tighten set screw (A).
2. Set both roller guides to within 1/32" of the saw blade by loosening the thumb screw (B) and turning the shaft (C) at rear of guide carrier. Do not set the roller guides too close as this will adversely affect the life of the saw blade. Tighten thumb screws.
3. Adjust the rear roller guide to be just clear of the back of the saw blade by unlocking the set screw (D) located on rear of guide carrier. Adjust shaft (E) and then lock the set screw (D).

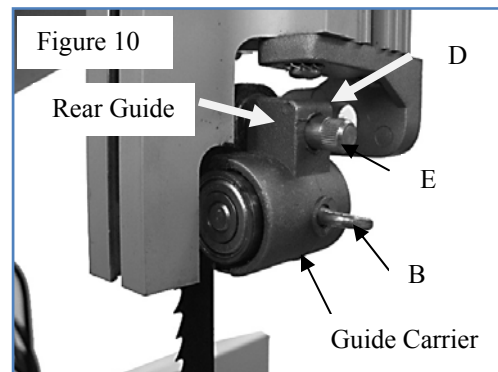
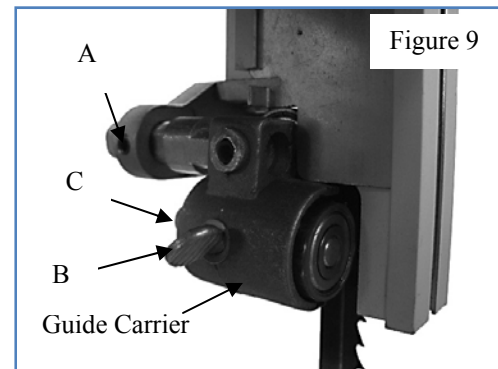

Tilting the table

For bevel cuts, the table tilts 0 through 45 degrees.

1. To tilt the table, loosen the locking handle on the table trunnion. Set the table to the required angle by turning adjustment knob (See Figure 11). Secure table in position by tightening locking handle.
2. It is recommended to verify the correct angle setting using an angle guide or by making trial cuts in scrap wood. Adjust the indicator accordingly by using a screwdriver.

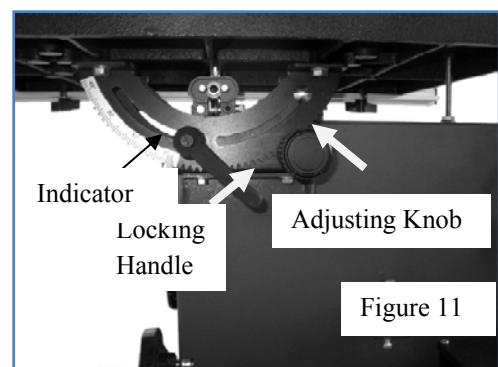

Adjusting the rip fence

The locking pressure of the rip fence has been factory-set.

The fence handle has a cam action, press down the handle to clamp tightly to the table after setting rip fence to desired position.

NOTE: The rip fence can be used on both sides of the blade. The rip fence extrusion needs to be positioned on the side of the fence body that is closest to the blade.

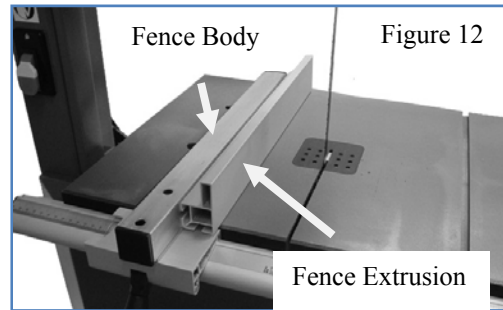

Blade speed adjustment

Refer to Figure 13



WARNING: Make sure the saw is disconnected from the power source before attempting to change the blade speed.

1. Open lower housing door.
2. Loosen drive belt by turning handwheel clockwise.
3. Position belt on desired pulley of blade wheel and motor. Belt must run on either both front or both rear pulleys only.
4. Drive belt on front pulleys (nearest to blade wheel) results in low blade speed.
5. Drive belt on rear pulleys (nearest to frame) results in high blade speed.
6. Tighten drive belt by turning handwheel counterclockwise.
7. Close lower housing door.

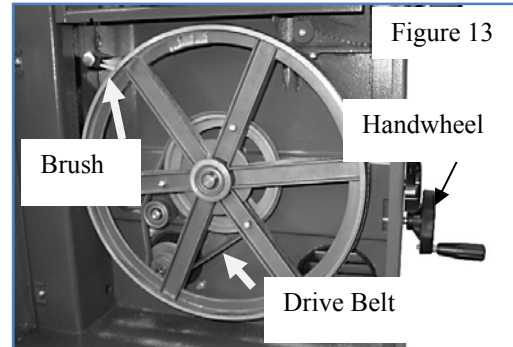

PUSH STICK

1. The push stick protects against accidental contact with the saw blade.
2. Always use the push stick when the distance between the saw blade and rip fence is less than 5 inches.
3. Hold the push stick at an angle of 25-30 degrees to the table surface and guide workpiece through the blade.
4. When the push stick is not in use, store it on the hook located at the top rear of the saw frame.

BLADE SELECTION

1. Blades vary depending on type of material, size of workpiece and type of cut that is being performed.
2. Characteristics which make blades different are width, thickness and pitch.

BLADE WIDTH

1. Width of blade describes distance from tip of a tooth to back of blade.
2. Width of blade affects rigidity of blade. A wider blade wanders less and produces a straighter cut.
3. Width of blade also limits the smallest radius which can be cut. A 1/4" wide blade can cut about a 1/2" radius.

BLADE THICKNESS

1. Blade thickness describes the distance between the sides of a blade. A thicker blade has more rigidity and stronger teeth.
2. A narrow thick blade is used to cut curves while a wide thin blade is used to make long, straight cuts.

BLADE PITCH

1. Pitch describes number of teeth per inch or tooth size. A blade with more teeth per inch produces a smoother cut.
2. The type of material being cut determines the number of teeth that should be in contact with the work piece.
3. For soft materials, the proper blade has between 6 to 8 teeth per inch.
4. When cutting hard materials where shocking is more detrimental, use a blade with 8 to 12 teeth per inch.
5. There should always be at least three teeth in contact with cut to avoid shocking the blade.
6. Blade shocking occurs when pitch is too large and blade tooth encounters too much material. This can strip teeth from blade.
7. Blade manufacturers are prepared to supply information about blades for specific applications.

TYPE OF CUT

1. Contour cutting is done by guiding workpiece freehanded to produce curved shapes.
2. Beveled cutting is done by tilting saw table and using proper work guide method.
3. Regardless of which work guiding method is used, a workpiece which overhangs table by more than 5" needs proper support.

CONTOUR SAWING

1. When contour sawing, use both hands to keep workpiece flat against table and guided along desired path.
2. Avoid positioning hands in line with the blade. If hands slip, they may contact blade.
3. Try to stand in front of the saw. Place hands over the portion of the table to the right of the blade before cutting.
4. Cut small corners by sawing around them. Saw to remove scrap until desired shape is obtained.

BEVEL CUTTING

1. Perform bevel cutting by tilting table to desired degree.
2. Unlock table by loosening the locking handle located on the backside of the unit
3. Tilt table to desired position.
4. Lock table in position by tightening locking handle.

MITER GAUGE

Use miter gauge for securing and holding workpiece at desired angle to produce angled cuts. Use scale to adjust gauge to desired angle. Insert gauge bar into table slot at table's front edge.



WARNING: Never use miter gauge and rip fence at the same time. The blade might bind in the workpiece. Operator could be injured and/or workpiece could be damaged.

BLADE CLEANING BRUSH

Refer to Figure 13.

Make sure that brush is in contact with blade to properly remove foreign particles from drive wheel.

Operation

ON/OFF Switch(Figure 14)

1. To turn the saw ON, move the switch to the up (ON) position.
2. To turn the saw OFF, move the switch to the down (OFF) position.
3. To lock the switch in the OFF position:
 - a) Wait until the band saw has come to a complete stop.
 - b) Remove the switch key from the switch housing. Store the switch key in a safe place.
4. To unlock the switch and turn the saw ON, insert the switch key into the switch, and move the switch to the ON position.

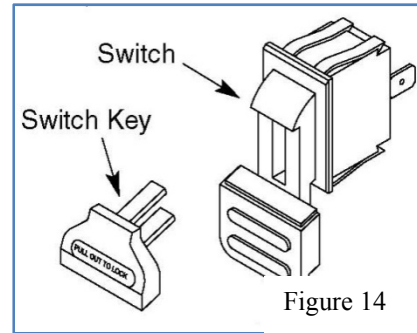

General Cutting



WARNING: Operating a band saw involves a certain amount of hazard. Read the instructions and plan your work before cutting a workpiece.

Use scrap lumber to check the settings and to get the feel of operating the band saw before attempting regular work.

Do not turn the power on before all adjustments have been made. Check to make sure the upper guard is in place. Always keep the upper blade guard close to your work, approximately 1/8" (3.2 mm) above the workpiece.

Do not force the workpiece against the blade. Light contact permits easier cutting and prevents unwanted friction and heating of the blade.

Sharp saw blades need limited pressure for cutting. Steadily move the workpiece against the blade without forcing it.

Use the band saw for straight-line operations such as crosscutting, ripping, miter cutting, beveling, compound cutting, and resawing.

To avoid twisting the blade, do not turn sharp corners; instead, saw around corners.

A band saw is basically a “curve-cutting” saw. It is not capable of doing intricate inside cutting as can be done with a scroll saw.



WARNING: Do not use this band saw to cut ferrous metals.

Cutting Curves

When cutting curves, carefully turn the work piece so the blade follows without twisting. If the curve is so sharp that you repeatedly back up and cut new kerf, use either a narrower blade or a blade with more set (teeth further apart). When a blade has more set, the work piece turns easier with a rougher cut.

When changing a cut, do not withdraw the work piece from the blade. The blade may get drawn off the wheels. To change a cut, turn the work piece and saw out through the scrap material area. When cutting long curves, make relief cuts as you go along.

Maintenance



WARNING: For your own safety, turn the switch OFF and remove the plug from the electrical outlet before performing maintenance or lubricating the band saw.

Remove the sawdust from the inside of the housing and blow out the sawdust from the motor.

Clean off pitch that accumulates on the table, blade guides, and bearings.

Remove pitch and dust from the upper and lower wheels using a stiff brush. Do not use solvents.

Apply a thin coat of automotive polish to the tabletop for a slick surface.

Replace the wheel tires when worn.



WARNING: Replace the power cord immediately if it is worn, cut, or damaged in any way.

Exploded view and parts list

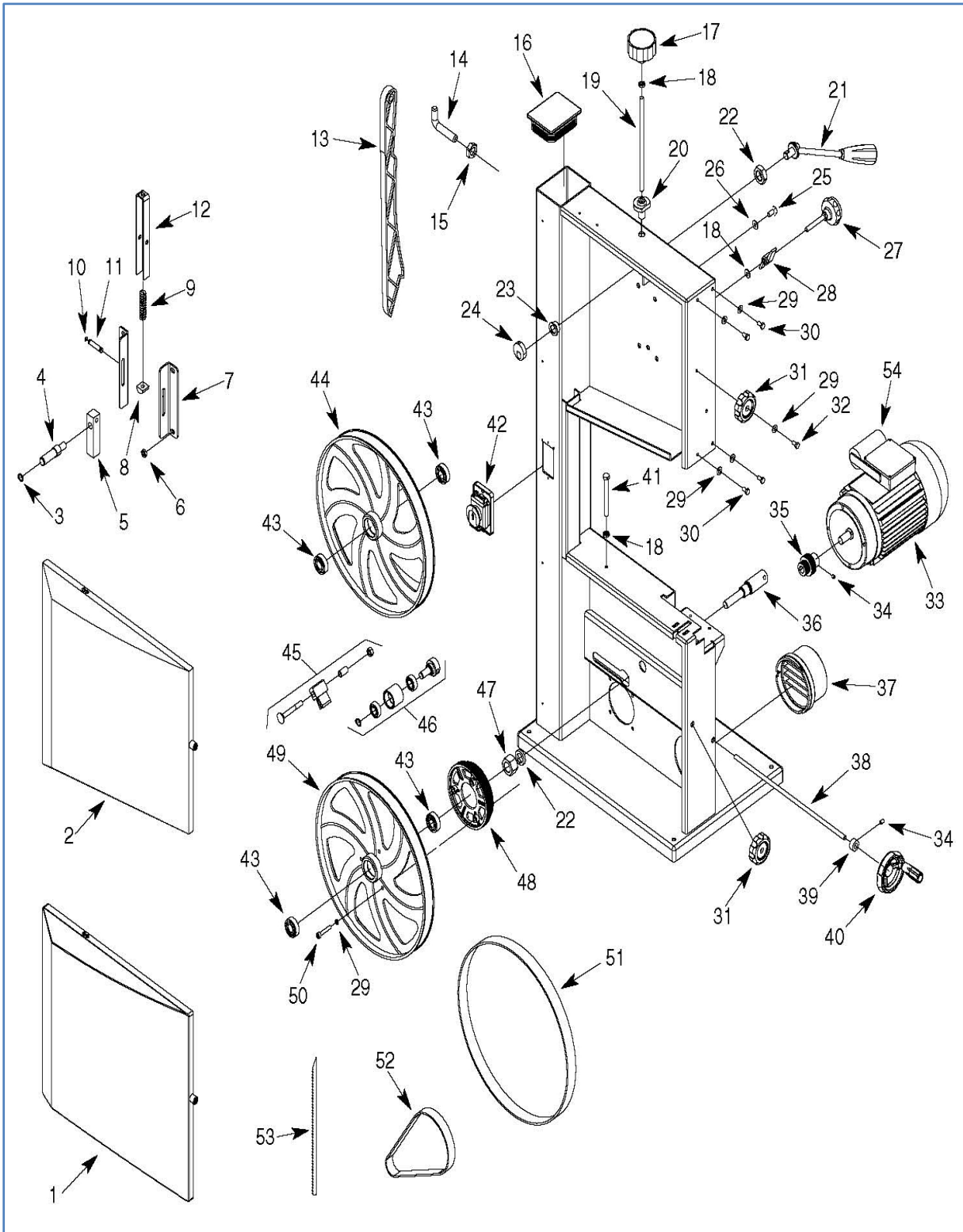

Item #	Stock #	Description
1	3914-101	Lower Door Assembly
2	3914-102	Upper Door Assembly
3	3914-103	Retaining Ring
4	3914-104	Upper Wheel Shaft
5	3914-105	Tension Block
6	3914-106	Flange Nut
7	3914-107	Guide Plate
8	3914-108	Nut
9	3914-109	Spring
10	3914-110	Shaft
11	3914-111	Retaining Ring
12	3914-112	Tension Bracket Frame
13	3914-113	Push Stick
14	3914-114	Hook
15	3914-115	Hex Nut
16	3914-116	Cap
17	3914-117	Tension Knob
18	3914-118	Jam Nut
19	3914-119	Threaded Rod
20	3914-120	Bushing
21	3914-121	Tension Release Handle
22	3914-122	Hex Nut
23	3914-123	Spacer
24	3914-124	Cam
25	3914-125	Hex Head Bolt
26	3914-126	Flat Washer
27	3914-127	Tracking Knob

Item #	Stock #	Description
28	3914-128	Wing Nut
29	3914-129	Flat Washer
30	3914-130	Hex Head Bolt
31	3914-131	Locking Knob
32	3914-132	Socket Head Bolt
33	3914-133	Motor
34	3914-134	Set Screw
35	3914-135	Motor Pulley
36	3914-136	Lower Wheel Shaft
37	3914-137	Dust Port
38	3914-138	Shaft
39	3914-139	Collar
40	3914-140	Handwheel Assembly
41	3914-141	Hex Head Bolt
42	3914-142	Switch Assembly
43	3914-143	Bearing 6202zz
44	3914-144	Upper Wheel
45	3914-145	Brush Assembly
46	3914-146	Belt Tension Drum Assembly
47	3914-147	Lock Washer
48	3914-148	Drive Pulley
49	3914-149	Lower Wheel
50	3914-150	Socket Head Bolt
51	3914-151	Tire
52	3914-152	Drive Belt
53	3914-153	Blade
54	3914-154	Capacitor

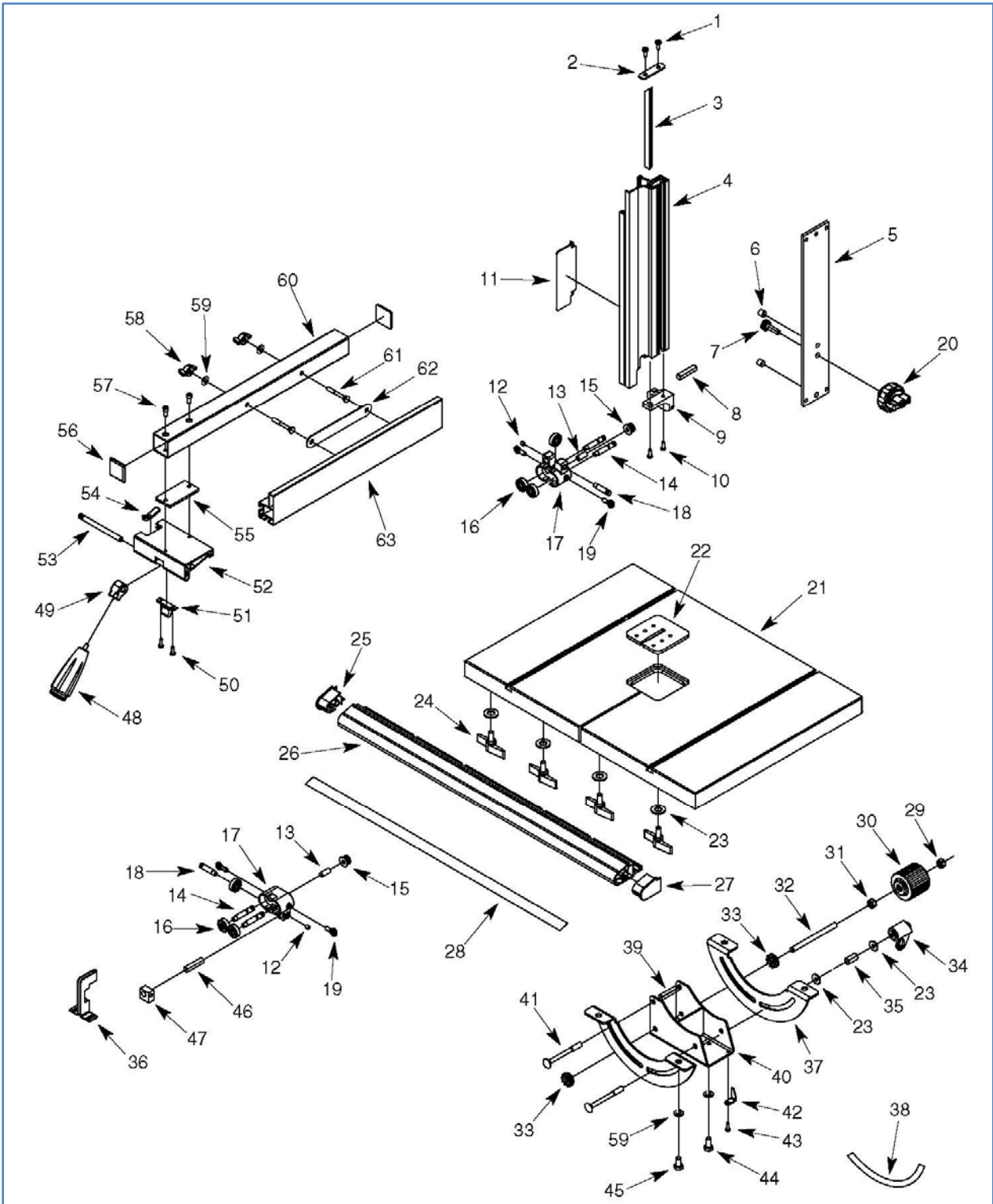

Item #	Stock #	Description
1	3914-201	Tap Screw
2	3914-202	Plate
3	3914-203	Rack
4	3914-204	Guide Post
5	3914-205	Pressure Plate
6	3914-206	Pin
7	3914-207	Rack Gear and Shaft
8	3914-208	Guide Block Pin
9	3914-209	Guide Carrier
10	3914-210	Tap Screw
11	3914-211	Sliding Guard
12	3914-212	Spacer
13	3914-213	Threaded Rod
14	3914-214	Guide Shaft
15	3914-215	Adjusting Nut
16	3914-216	Bearing 627zz
17	3914-217	Guide Block
18	3914-218	Shaft
19	3914-219	Thumb Screw
20	3914-220	Guide Adjusting Knob
21	3914-221	Table
22	3914-222	Table Insert
23	3914-223	Flat Washer
24	3914-224	Wing Bolt
25	3914-225	Fence Rail Left Cap
26	3914-226	Fence Rail
27	3914-227	Fence Rail Right Cap
28	3914-228	Scale
29	3914-229	Hex Nut
30	3914-230	Knob
31	3914-231	Nut
32	3914-232	Shaft
33	3914-233	Gear

Item #	Stock #	Description
34	3914-234	Locking Handle
35	3914-235	Spacer
36	3914-236	Lower Blade Guard
37	3914-237	Trunnion
38	3914-238	Angle Scale
39	3914-239	Spacer
40	3914-240	Trunnion Bracket
41	3914-241	Bolt
42	3914-242	Indicator
43	3914-243	Screw
44	3914-244	Bolt
45	3914-245	Bolt
46	3914-246	Locking Pin
47	3914-247	Lower Guide Seat
48	3914-248	Handle Assembly
49	3914-249	Cam
50	3914-250	Tap Screw
51	3914-251	Pressure Plate
52	3914-252	Fence Carrier
53	3914-253	Shaft
54	3914-254	Lens
55	3914-255	Plate
56	3914-256	Cap
57	3914-257	Bolt
58	3914-258	Wing Nut
59	3914-259	Washer
60	3914-260	Fence Bracket
61	3914-261	Bolt
62	3914-262	Plate
63	3914-263	Fence
64	3914-264	Rip Fence Assy
65	3914-265	Miter Gauge

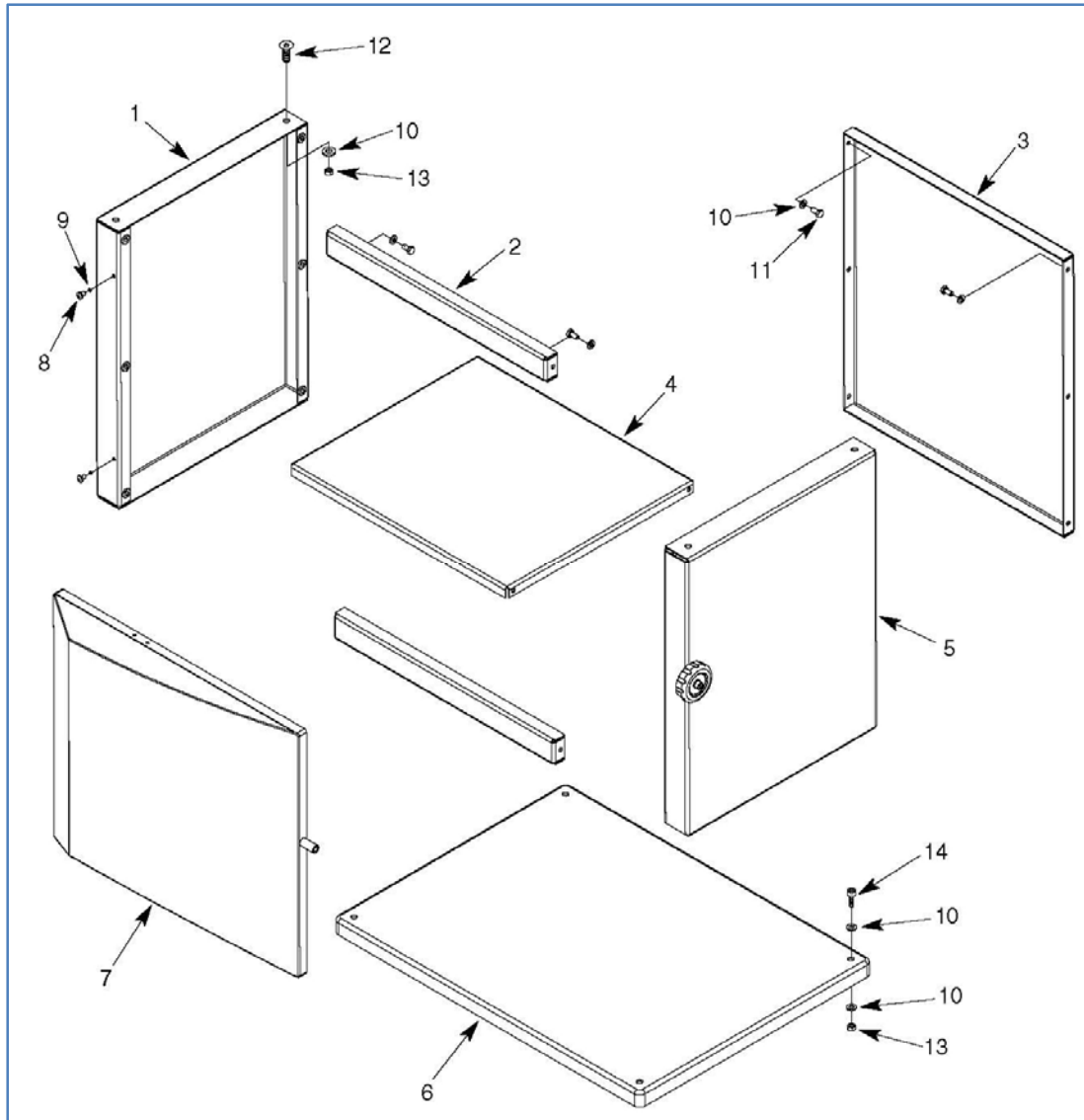

Item #	Stock #	Description
1	3914-301	Left Panel
2	3914-302	Brace
3	3914-303	Rear Panel
4	3914-304	Shelf
5	3914-305	Right Panel
6	3914-306	Base
7	3914-307	Door Assembly

Item #	Stock #	Description
8	3914-308	Screw
9	3914-309	Flat Washer
10	3914-310	Flat Washer
11	3914-311	Bolt
12	3914-312	Screw
13	3914-313	Nut
14	3914-314	Bolt

Limited two years warranty

WEN Products is committed to build tools that are dependable for years. Our warranties are consistent with this commitment and our dedication to quality.

LIMITED WARRANTY OF WEN CONSUMER POWER TOOLS PRODUCTS FOR HOME USE

GREAT LAKES TECHNOLOGIES, LLC ("Seller") warrants to the original purchaser only, that all WEN consumer power tools will be free from defects in material or workmanship for a period of two (2) years from date of purchase. Ninety days for all WEN products, if the tool is used for professional use.

SELLER'S SOLE OBLIGATION AND YOUR EXCLUSIVE REMEDY under this Limited Warranty and, to the extent permitted by law, any warranty or condition implied by law, shall be the repair or replacement of parts, without charge, which are defective in material or workmanship and which have not been misused, carelessly handled, or misrepaired by persons other than Seller or Authorized Service Center. To make a claim under this Limited Warranty, please contact us at 1-800-232-1195.. To acquire service, you will have to provide proof of purchase and may be asked to ship the tool back to us freight prepaid.

THIS LIMITED WARRANTY DOES NOT APPLY TO ACCESSORY ITEMS SUCH AS CIRCULAR SAW BLADES, DRILL BITS, ROUTER BITS, JIGSAW BLADES, SANDING BELTS, GRINDING WHEELS AND OTHER RELATED ITEMS.

ANY IMPLIED WARRANTIES SHALL BE LIMITED IN DURATION TO ONE (1) YEAR FROM DATE OF PURCHASE. SOME STATES IN THE U.S., SOME CANADIAN PROVINCES DO NOT ALLOW LIMITATIONS ON HOW LONG AN IMPLIED WARRANTY LASTS, SO THE ABOVE LIMITATION MAY NOT APPLY TO YOU.

IN NO EVENT SHALL SELLER BE LIABLE FOR ANY INCIDENTAL OR CONSEQUENTIAL DAMAGES (INCLUDING BUT NOT LIMITED TO LIABILITY FOR LOSS OF PROFITS) ARISING FROM THE SALE OR USE OF THIS PRODUCT. SOME STATES IN THE U.S. AND SOME CANADIAN PROVINCES DO NOT ALLOW THE EXCLUSION OR LIMITATION OF INCIDENTAL OR CONSEQUENTIAL DAMAGES, SO THE ABOVE LIMITATION OR EXCLUSION MAY NOT APPLY TO YOU.

THIS LIMITED WARRANTY GIVES YOU SPECIFIC LEGAL RIGHTS, AND YOU MAY ALSO HAVE OTHER RIGHTS WHICH VARY FROM STATE TO STATE IN THE U.S., PROVINCE TO PROVINCE IN CANADA AND FROM COUNTRY TO COUNTRY.

THIS LIMITED WARRANTY APPLIES ONLY TO PORTABLE ELECTRIC TOOLS, BENCH POWER TOOLS, OUTDOOR POWER EQUIPMENT AND PNUMATIC TOOLS SOLD WITHIN THE UNITED STATES OF AMERICA, CANADA AND THE COMMONWEALTH OF PUERTO RICO. FOR WARRANTY COVERAGE WITHIN OTHER COUNTRIES, CONTACT THE WEN CUSTOMER SUPPORT.



WWW.WENPRODUCTS.COM

Free Manuals Download Website

<http://myh66.com>

<http://usermanuals.us>

<http://www.somanuals.com>

<http://www.4manuals.cc>

<http://www.manual-lib.com>

<http://www.404manual.com>

<http://www.luxmanual.com>

<http://aubethermostatmanual.com>

Golf course search by state

<http://golfingnear.com>

Email search by domain

<http://emailbydomain.com>

Auto manuals search

<http://auto.somanuals.com>

TV manuals search

<http://tv.somanuals.com>