



BLACK & DECKER®

6 VOLT / 12 VOLT
AUTOMATIC BATTERY MAINTAINER

INSTRUCTION MANUAL

Catalog
Number
BM3B

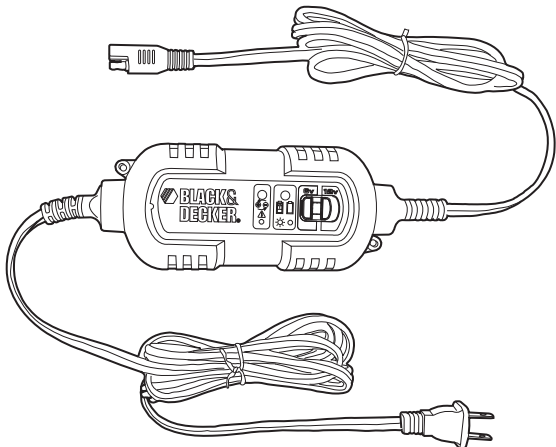

SAFETY GUIDELINES / DEFINITIONS

SAFETY GUIDELINES - DEFINITIONS

It is important for you to read and understand this manual. The information it contains relates to protecting YOUR SAFETY and PREVENTING PROBLEMS. The symbols below are used to help you recognize this information.

⚠ DANGER: Indicates an imminently hazardous situation which, if not avoided, will result in death or serious injury.

⚠ WARNING: Indicates a potentially hazardous situation which, if not avoided, could result in death or serious injury.

⚠ CAUTION: Indicates a potentially hazardous situation which, if not avoided, may result in minor or moderate injury.

CAUTION: Used without the safety alert symbol indicates a potentially hazardous situation which, if not avoided, may result in property damage.

IMPORTANT SAFETY INSTRUCTIONS

⚠ GENERAL SAFETY WARNINGS AND INSTRUCTIONS FOR ALL APPLIANCES

READ ALL INSTRUCTIONS

⚠ WARNING: Read all instructions before operating product. Failure to follow all instructions listed below may result in electric shock, fire and/or serious injury.

- **AVOID DANGEROUS ENVIRONMENTS.** Don't use appliances in damp or wet locations. Don't use appliances in the rain.
- **INTENDED FOR INDOOR AND HOUSEHOLD USE UNDER DRY CONDITION.**
- **KEEP CHILDREN AWAY.** All visitors should be kept at a distance from work area.
- **STORE IDLE APPLIANCES INDOORS.** When not in use, appliances should be stored indoors in dry, and high or locked-up place – out of reach of children.
- **DON'T FORCE APPLIANCE.** It will do the job better and with less likelihood of a risk of injury at the rate for which it was designed.
- **USE RIGHT APPLIANCE.** Do not use the appliance for any job except that for which it is intended.
- **DRESS PROPERLY.** Do not wear loose clothing or jewelry. They can be caught in moving parts. Rubber gloves and substantial, non-skid footwear are recommended when working outdoors. Wear protective hair covering to contain long hair.
- **USE SAFETY GLASSES AND OTHER SAFETY EQUIPMENT.** Use safety goggles or safety glasses with side shields, complying with applicable safety standards and, when needed, a face shield. Also use face or dust mask if operation is dusty. This applies to all persons in the work area. Also use a hard hat, hearing protection, gloves, safety shoes and dust collection systems when specified or required. Safety glasses or the like are available at extra cost at your local dealer or Black & Decker Service Center.
- **DON'T ABUSE CORD.** Never carry appliance by cord or yank it to disconnect from receptacle. Keep cord from heat, oil, and sharp edges.
- **DON'T OVERREACH.** Keep proper footing and balance at all times.
- **DISCONNECT APPLIANCES.** Disconnect the appliance from the power supply when not in use, before servicing, and when changing accessories.
- **AVOID UNINTENTIONAL STARTING.** Don't carry plugged-in appliance with finger on switch.
- **GROUND FAULT CIRCUIT INTERRUPTER (GFCI)** protection should be provided on the circuits or outlets to be used. Receptacles are available having built in GFCI protection and may be used for this measure of safety.
- **USE OF ACCESSORIES AND ATTACHMENTS.** The use of any accessory or attachment not recommended for use with this appliance could be hazardous. Note: Refer to the accessory section of this manual for further details.
- **STAY ALERT.** Watch what you are doing. Use common sense. Do not operate tool when you are tired.
- **CHECK DAMAGED PARTS.** Before further use of the tool, that is damaged should be carefully checked to determine that it will operate properly and perform its intended function. Check for alignment of moving parts, binding of moving parts, breakage of parts, mounting, and any other conditions that may affect its operation. A guard or other part that is damaged should be properly repaired or replaced by an authorized service center unless otherwise indicated elsewhere in this instruction manual. Have defective switches replaced by authorized service center. Do not use tool if switch does not turn it on and off.
- **DO NOT OPERATE** portable electric tools near flammable liquids or in gaseous or explosive atmospheres. Motors in these tools normally spark, and the sparks might ignite fumes.
- **EXTENSION CORDS.** Make sure your extension cord is in good condition. When using an extension cord, be sure to use one heavy enough to carry the current your product will draw. An undersized cord will cause a drop in line

voltage resulting in loss of power and overheating. The following table shows the correct size to use depending on cord length and nameplate ampere rating. If in doubt, use the next heavier gage. The smaller the gage number, the heavier the cord.

Volts	Minimum Gage for Cord Sets			
	Total Length of Cord in Feet			
120V	0-25 (0-7,6m)	26-50 (7,6-15,2m)	51-100 (15,2-30,4m)	101-150 (30,4-45,7m)
240V	0-50 (0-15,2m)	51-100 (15,2-30,4m)	101-200 (30,4-60,9m)	201-300 (60,9-91,4m)
Ampere Rating		American Wire Gage		
More Than	Not more Than			
0 -	6	18	16	16
6 -	10	18	16	14
10 -	12	16	16	14
12 -	16	14	12	Not Recommended

⚠ WARNING: BURST HAZARD: Do not use the unit for charging dry-cell batteries that are commonly used with home appliances. These batteries may burst and cause injury to persons and damage property. Use the unit for charging a LEAD-ACID battery only. It is not intended to supply power to a low-voltage electrical system other than in a starter-motor application.

⚠ WARNING: SHOCK HAZARD:

- If an extension cord is used, make sure that:
 - a) the pins of extension cord are the same number, size and shape as those in the battery maintainer,
 - b) the extension cord is properly wired and in good electrical condition,
 - c) the wire size is large enough for the AC rating of the charger as indicated in the table on page 3.
- Do not operate unit with damaged cord or plug; or if the unit has received a sharp blow, been dropped, or otherwise damaged in any way. Do not disassemble the unit; take it to a qualified service technician when service or repair is required. Incorrect reassembly may result in a risk of electric shock or fire, and will void warranty.
- Use of an attachment not supplied, recommended or sold by manufacturer specifically for use with this unit may result in a risk of electrical shock and injury to persons.
- NEVER submerge this unit in water; do not expose it to rain, snow or use when wet.
- To reduce risk of electric shock, disconnect the unit from any power source before attempting maintenance or cleaning. Turning off controls without disconnecting will not reduce this risk.

⚠ WARNING: RISK OF EXPLOSIVE GASES:

- Working in the vicinity of a lead acid battery is dangerous. Batteries generate explosive gases during normal battery operation. For this reason, it is of the utmost importance that each time before using the battery maintainer you read this manual and follow instructions exactly.
- To reduce the risk of battery explosion, follow these instructions and those published by the battery manufacturer and manufacturer of any equipment you intend to use in the vicinity of the battery. Review cautionary markings on these products and on the engine.
- This equipment employs parts (switches, relays, etc.) that produce arcs or sparks. Therefore, if used in a garage or enclosed area, the unit MUST be placed not less than 18 inches above the floor.
- THIS UNIT IS NOT FOR USE BY CHILDREN AND SHOULD ONLY BE OPERATED BY ADULTS.

⚠ CAUTION: TO REDUCE THE RISK OF INJURY OR PROPERTY DAMAGE:

- Pull cord by plug rather than cord when disconnecting the 120V AC Charging Adapter from the unit.
- NEVER ATTEMPT TO JUMP-START OR CHARGE A FROZEN BATTERY.
- Vehicles that have on-board computerized systems may be damaged if vehicle battery is connected to the vehicle during the operation of the battery maintainer. Before maintaining the battery with the battery maintainer, read the vehicle's owner's manual to confirm proper method of maintaining vehicle battery.
- When working with lead acid batteries, always make sure immediate assistance is available in case of accident or emergency.
- Always wear protective eyewear when using this product: contact with battery acid may cause blindness and/or severe burns. Be aware of first aid procedures in case of accidental contact with battery acid.
- Have plenty of fresh water and soap nearby in case battery acid contacts skin.
- If battery acid contacts skin or clothing, wash immediately with soap and water for at least 10 minutes and get medical attention immediately.
- Never smoke or allow a spark or flame in vicinity of vehicle battery, engine or battery maintainer.
- Remove personal metal items such as rings, bracelets, necklaces and watches when working with a lead acid battery. A lead acid battery can produce a short circuit current high enough to weld a ring, or the like of a metal, causing a severe burn.
- Never allow battery acid to come in contact with this unit.
- Do not operate this unit in a closed area or restrict ventilation in any way.

- **FIRST AID – SKIN:** If battery acid comes in contact with skin, rinse immediately with water, then wash thoroughly with soap and water. If redness, pain, or irritation occurs, seek immediate medical attention.
- EYES:** If battery acid comes in contact with eyes, flush eyes immediately, for a minimum of 15 minutes and seek immediate medical attention.

Preparing to Charge

1. Determine voltage of battery to be maintained by referring to the vehicle manual.
2. If it is necessary to remove battery from vehicle to maintain, or to clean terminals, always remove grounded terminal from battery first. Make sure all accessories in the vehicle are off, so as not to cause an arc.
3. Clean battery terminals. Do not allow corrosion to come in contact with eyes.
4. Add distilled water in each cell until battery acid reaches level specified by battery manufacturer. This helps purge excessive gas from cells. Do not overfill and always replace caps. For a battery without cell caps (maintenance free), carefully follow battery manufacturer's charging and maintenance instructions.
5. Study all battery manufacturer's specific precautions, while charging, and recommended rates of charge.
6. Area around battery should be well ventilated while battery is being charged. Do not operate within an enclosed area.

⚠ CAUTION: This battery maintainer does not detect, diagnose or analyze the condition of the battery. Attempting to charge/maintain a battery with an abnormal condition can further damage the battery. If in doubt, have the battery checked by a qualified professional prior to using the BM3B maintainer.

Charger Location

1. Locate battery maintainer as far away from battery as cables permit.
2. Charge above freezing temperature and below 40 degree Celsius (C) (104 degree Fahrenheit).
3. NEVER place battery maintainer directly above battery being charged; gases from battery will corrode and damage charger.
4. NEVER allow battery acid to drip on battery maintainer when reading gravity or filling battery.
5. NEVER operate battery maintainer in a closed-in area or restrict ventilation in any way.
6. Marine batteries must be removed and charged on shore.
7. Do not set a battery on top of battery maintainer.

Follow these steps when the battery is installed in a vehicle. A spark near the battery may cause an explosion.

⚠ WARNING: TO REDUCE RISK OF A SPARK NEAR THE BATTERY: CONNECT AND DISCONNECT DC OUTPUT CLAMPS AND RING TERMINALS ONLY AFTER REMOVING AC CORD FROM ELECTRIC OUTLET.

1. Position AC and DC cords away from hood, door, or moving engine parts.
2. Stay clear of fan blades, belts, pulleys, and other parts that can cause injury to persons.
3. Check polarity of battery posts. POSITIVE (POS, P, +) battery post usually has larger diameter than NEGATIVE (NEG, N, -) post.
4. Determine which post of battery is grounded (connected) to the chassis. If negative post is grounded to chassis (as in most vehicles), see 5. If positive post is grounded to the chassis, see 6.
5. For negative-grounded vehicle, connect POSITIVE (RED) clamp from battery charger to POSITIVE (POS, P, +) ungrounded post of battery. Connect NEGATIVE (BLACK) clamp to vehicle chassis or engine block away from battery. Do not connect clip to carburetor, fuel lines, or sheet-metal body parts. Connect to heavy gauge metal part of the frame or engine block.
6. For positive-grounded vehicle, connect NEGATIVE (BLACK) clamp from battery charger to NEGATIVE (NEG, N, -) ungrounded post of battery. Connect POSITIVE (RED) clamp to vehicle chassis or engine block away from battery. Do not connect clip to carburetor, fuel lines or sheet-metal body parts. Connect to a heavy gauge metal part of the frame or engine block.
7. When disconnecting charger, disconnect AC cord, remove clamp from vehicle chassis, and then remove clamp from battery terminal.
8. Do not charge the battery while the engine is operating.
9. Refer to battery manufacturer's instruction on battery charging/maintaining procedures.

DC Connection Precautions

1. Remove AC cord from electric outlet before connecting or disconnecting DC clamps and ring terminals.
2. Never allow clamps to touch each other.

Follow these steps when the battery has been removed from a vehicle. A spark near the battery may cause an explosion.

⚠ WARNING: TO REDUCE RISK OF A SPARK NEAR THE BATTERY: CONNECT OR DISCONNECT DC OUTPUT CLAMPS ONLY AFTER REMOVING AC CORD FROM ELECTRICAL OUTLET.

1. Check polarity of battery posts. Positive post (marked POS,P, +) usually has a larger diameter than the Negative battery post (marked NEG, N, -).

2. Attach a 24-inch (minimum length) 6 AWG insulated battery cable to the Negative battery post (marked NEG, N, -).
3. Connect the Positive (RED) battery clamp to the Positive battery post (marked POS, P, + or red).
4. Stand as far back from the battery as possible, and do not face battery when making final connection.
5. Carefully connect the NEGATIVE (BLACK) charger clamp to the free end of the battery cable connected to the negative terminal.
6. Set the charge voltage to appropriate setting according to battery voltage.
7. When disconnecting maintainer, always do so in reverse sequence of connecting procedure. Remove the connection from the 6AWG cable (mentioned in step #2) as far away from the battery as possible. Break first connection while as far away from battery as practical.

Note: A marine (boat) battery must be removed and charged on shore. To charge it on board requires equipment specially designed for marine use. This unit is NOT designed for such use.

- Check unit periodically for wear and tear. Take to a qualified technician for replacement of worn or defective parts immediately.
- Read This Instruction Manual Before Using This Unit.

SAVE THESE INSTRUCTIONS

⚠ WARNING: TO REDUCE THE RISK OF INJURY:

Follow these instructions and those published by the battery manufacturer and manufacturer of any equipment you intend to use with this unit. Review cautionary markings on these products and on engine.

INTRODUCTION

Thank you for selecting the **Black & Decker® 1 Amp Charge Rate Automatic Battery Maintainer**. With proper care and use, it will give you years of dependable service. Please read and observe all safety warnings and cautions and this entire user's instruction manual, before installing or using this device. The instruction manual should then be retained for quick reference whenever the unit is used. **Figure 1** shows the battery maintainer and its components.

This device complies with part 15 of the FCC rules. Operation is subject to the following two conditions: (1) this device may not cause harmful interference, and (2) this device must accept any interference received, including interference that may cause undesired operation.

This equipment has been tested and found to comply with the limits for a Class B digital device, pursuant to part 15 of the FCC Rules. This limits are designed to provide reasonable protection against harmful interference in a residential installation. This equipment generates, uses and can radiate radio frequency energy and, if not installed and used in accordance with the instructions, may cause harmful interference to radio communications. However, there is no guarantee that interference will not occur in a particular installation. If equipment does cause harmful interference to radio or television reception, which can be determined by turning the equipment off and on, the user is encouraged to try to correct the interference by one or more of the following measures:

- Reorient or relocate the receiving antenna.
- Increase the separation between equipment and receiver.
- Connect the equipment into an outlet on a circuit different from that to which the receiver is connected.
- Consult the dealer or an experienced radio/TV technician for help.

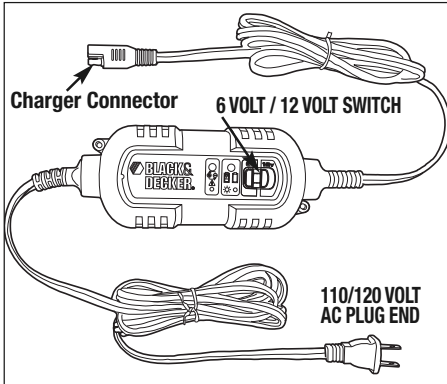
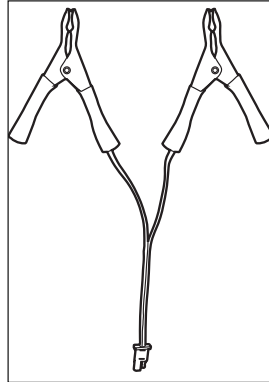
1**6V/12V BATTERY MAINTAINER****BATTERY TERMINAL RINGS****BATTERY TERMINAL CLAMPS****DC ACCESSORY PLUG****FEATURES**

- The unit has two voltage rate settings (6v, 12v), controlled by one switch:
 - a) Use for battery maintenance, charging RVs, speciality vehicles, antique and classic cars, marine deep cycle batteries, motorcycles, lawn mowers, tractors, ATVs, snowmobiles, personal watercraft and more.
- Maintains battery charge in stored vehicles
- Includes three connector sets:
 - a) DC accessory plug
 - b) Battery harness clips
 - c) Battery ring terminal harness
- Charging indicators:
 - a) Red – bad connection, battery not able to accept charge, reverse polarity hook-up
 - b) Blinking Green – connection correct and charging
 - c) Solid Green – fully charged
- ETL-Listed for safety
- Fully automatic; powers on when needed, powers off when battery is fully-charged or topped-off
- Built-in circuit protection guards against overcharging or short circuit
- Automatically checks for correct polarity (requires a minimum of 2.0 volts battery voltage)
- Convenient, color-coded ring terminals/clamps for easy, correct installation
- Charges with high frequency, pure, DC current

Mounting Instructions:

BM3B battery maintainer is designed to be able to mount to flat surface.

The unit has incorporated two mounting holes at the corners of the unit.

Note: Always disconnect the maintainer at AC power source and at battery terminal when mounting the unit.

To mount the unit:

1. Make sure the surface is flat and free of obstruction so the unit can rest flat on the surface.
2. Make sure the unit is disconnected from both AC power source and the battery.
3. Use 8/32 inches (6.35mm) wood screw to mount the unit through the mounting hole.
4. Do not over tighten the screw, it will damage the housing.
5. Connect the unit to AC power outlet and the unit is ready for use.

⚠ WARNING: Do not put the screw through the plastic housing as this will permanently damage the unit and cause potential electrical hazard.

OPERATING INSTRUCTIONS

Ensure that all installation and operating instructions and safety precautions are understood and carefully followed by anyone installing or using the charger. Follow the steps outlined in "Important Safety Instructions" at the front of this manual.

Charging Indicators

Red LED – Bad connection, reverse polarity connection; check that the RED clamp is connected to + battery terminal.
 Blinking Green LED – Connection correct and charging
 Solid Green LED – Battery fully charged

When the charger is properly connected, the LED will illuminate, indicating the inside smart circuit is functioning to judge the battery status. This procedure may take up to 2 minutes if battery voltage is lower than 12.8 volts.

Setting the Voltage

The unit has two voltage rate settings (6v, 12v), controlled by one switch. Set the switch to either 6v or 12v depending upon the battery you are charging.

Connecting the Charger with the Terminal Clamps

The charger's output leads have color-coded battery clamps (**Figure 2**) (RED-POSITIVE and BLACK-NEGATIVE).

1. Disconnect battery and remove the battery from vehicle.
2. Unplug the battery maintainer AC cord from the AC outlet.
3. Disconnect the battery clamps from the unit at output cord connector.
4. Connect the RED POSITIVE clamp to the POSITIVE post of the battery.
5. Connect the BLACK NEGATIVE clamp to the NEGATIVE post of the battery.
6. Connect the battery clamp connector with the unit connector, as far away from the battery as possible.
7. Slide the voltage selector to proper setting and plug the AC cord to AC outlet
8. Observe blinking GREEN LED, indicates unit is operating.
9. Monitor the unit periodically.

⚠ WARNING: FOLLOW THE STEPS OUTLINED IN "IMPORTANT SAFETY INSTRUCTIONS" AT THE FRONT OF THIS MANUAL AND THE WARNING AT THE BOTTOM OF PAGE 4, "TO REDUCE RISK OF A SPARK NEAR THE BATTERY"

Connecting the Charger with Terminal Rings

The charger's output leads have crimped, color-coded ring terminals (**Figure 3**) (RED-POSITIVE and BLACK-NEGATIVE). These rings connect directly to the corresponding connectors on the battery posts.

1. Remove the nuts from the bolts of the battery post's connectors.
2. Position the RED terminal on the bolt of the POSITIVE battery post connector.
3. Position the BLACK terminal on the NEGATIVE post connector; then replace the nuts.
4. If there is any problem connecting the output leads, check with a reputable auto supply store or contact the Customer Service Department toll-free at (800) 544-6986 for assistance in finding an appropriate connection device for your particular application.

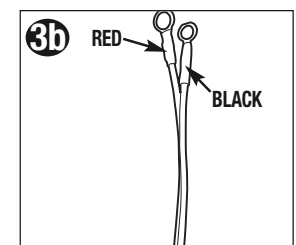
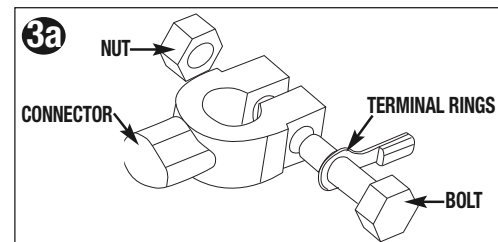
**Charging With Ring Terminals**

1. Disconnect AC power cord from AC power outlet
2. Disconnect battery terminal clamps and DC accessory plug from the maintainer output cable, at connector
3. With the ring terminals connected (fig. 3a) and with ring terminal connector held as far away from battery, connect to the maintainer output cord. If the maintainer red LED is lit, check ring terminal connections at battery.
4. Slide the voltage selector switch to 6V or 12V
5. Connect AC power
6. The unit should be working with blinking green LED, indicating the battery is being charged.

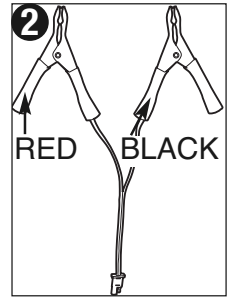

Connecting the Maintainer and Maintaining the Battery with the DC Accessory Plug

The charger's output leads also contain a DC accessory plug (Figure 4).

Note: ALWAYS disconnect the AC power cord from the AC power outlet before connecting (or disconnecting) the charger to (or from) the battery.

1. Slide the Voltage Selector switch to 6v or 12v.
2. Insert the DC plug into the vehicle's DC accessory outlet.
3. Insert the AC plug of the charger into any standard 110/120 volt AC wall outlet.

Note: Some vehicles require that the ignition be turned to the ACC (accessory) position to activate the DC accessory outlet. If your vehicle ignition is required to be turned to the ACC position, be sure all the vehicle accessories (i.e. heater, fan, radio, TV, lights... etc) are turned off. If not turned off, the maintainer might not be able to maintain the battery.

Charging the Battery

1. Leave the unit on.
2. Monitor the battery from time to time.

Fuse Replacement (DC Accessory Adapter)

1. Disconnect AC power from the outlet and disconnect adaptor from the output cord.
2. Remove plug from accessory outlet. Remove the plastic cap by turning counterclockwise and lifting off.
3. Remove center pin and spring. Remove fuse.
4. Replace fuse with same type and size fuse (5 amp).
5. Replace center pin and spring inside plug.
6. Replace the plastic cap by turning clockwise.

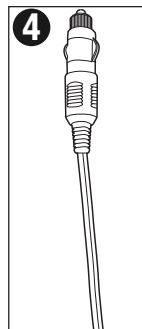

TROUBLESHOOTING

Unit Not Charging

- Check that the charger is properly connected to a live 120 volt AC outlet (the LED will illuminate).
- Check that the correct voltage setting has been selected for the battery being maintained.
- If the battery to be maintained has fallen below 2 volts, the battery cannot be recharged with this unit.
- Make sure output connection are secured.
- Check correct polarity connections.
- If the maintainer does not detect battery voltage, the unit will not run.

⚠ WARNING: During troubleshooting, if there is a need to connect/disconnect the unit from battery, follow the steps outlined in "Important Safety Instructions" at the front of this manual and the warning on page 4 and 5, "To reduce risk of a spark near the battery".

CARE AND MAINTENANCE

With proper care and minimal maintenance, the Automatic Battery Maintainer will provide years of dependable service. For maximum performance, manufacturer recommends:

1. Storing the unit in a clean, dry, cool place when not in use.
2. Cleaning the unit casing and cords (as necessary) with a dry (or slightly damp) cloth. Ensure that unit is completely disconnected from battery and power source, before cleaning.
3. To maintain the operating condition and maximize the life of the charger cords, always coil them loosely for storage. Do not wrap them around the unit or crimp them with a tight band.

⚠ WARNINGS:

- Do not use charger if cords have been damaged in any way — call Technical Support toll-free at (800) 544-6986.
- There are no user-serviceable parts in this unit.
- Do not open the unit. In the event of malfunction, it must be returned to manufacturer for professional testing and repair. Opening the unit will void the manufacturer's warranty.

Free Manuals Download Website

<http://myh66.com>

<http://usermanuals.us>

<http://www.somanuals.com>

<http://www.4manuals.cc>

<http://www.manual-lib.com>

<http://www.404manual.com>

<http://www.luxmanual.com>

<http://aubethermostatmanual.com>

Golf course search by state

<http://golfingnear.com>

Email search by domain

<http://emailbydomain.com>

Auto manuals search

<http://auto.somanuals.com>

TV manuals search

<http://tv.somanuals.com>