

how to use and enjoy your

Sewing Machine

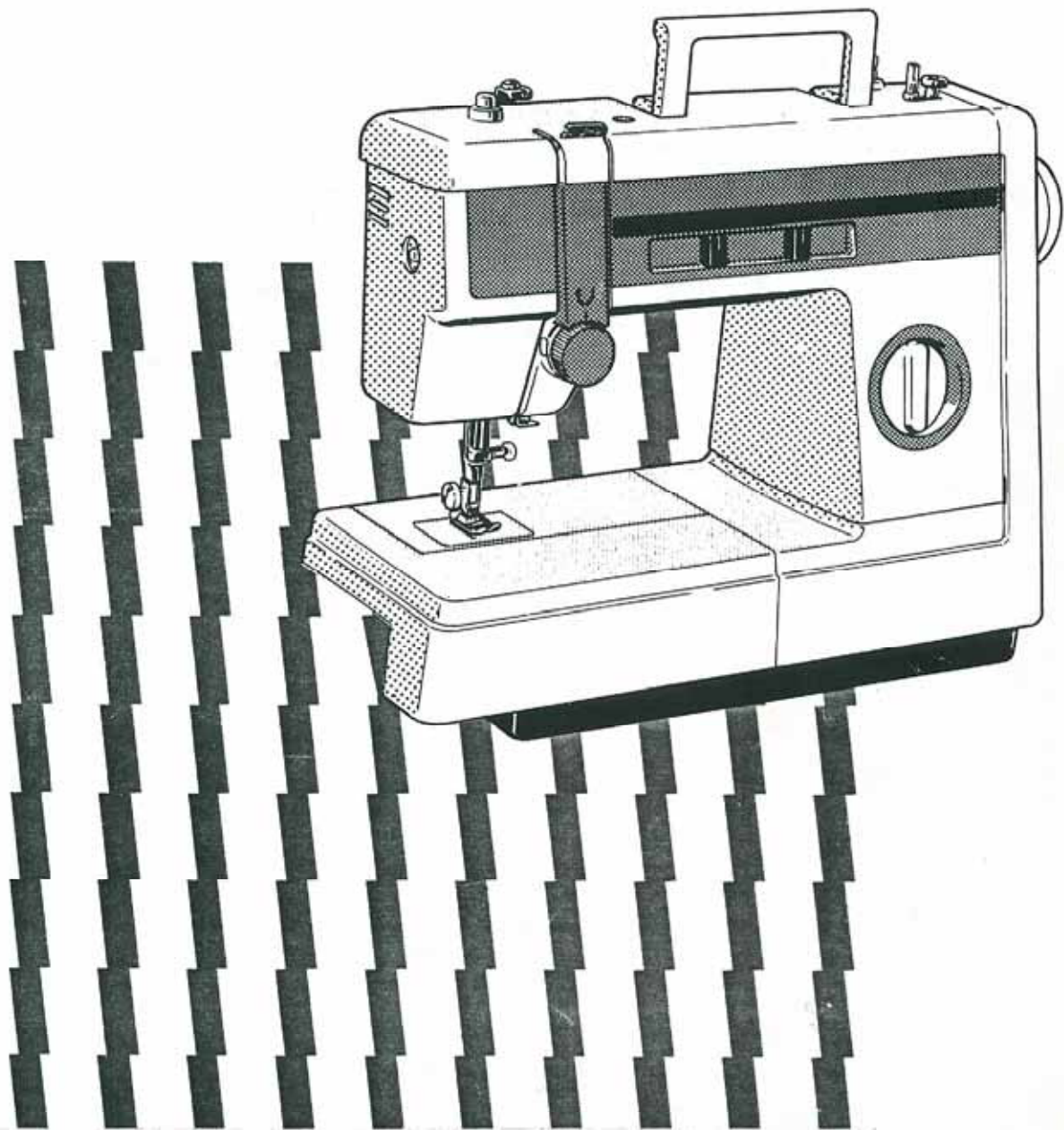

CAUTION

When leaving the sewing machine unattended, the plug must be removed from the socket-outlet. When servicing the sewing machine, or when removing covers or changing lamps, the machine must be disconnected from the supply by removing the plug from the socket-outlet.

CONTENTS

1	Knowing Your Sewing Machine	2
----------	------------------------------------	----------

PRINCIPAL PARTS	2
MACHINE COVER.	3
ACCESSORIES	4
OPERATING YOUR SEWING MACHINE.	5
Connecting plugs	5
Controlling sewing speed.	5
VARIOUS CONTROL.	6
Stitch length knob	6
Reverse sewing knob	6
Stitch width knob	6
Needle position selector	7
PRESSER FOOT	7
NEEDLE.	8
How to change the needle	8
How to check the needle.	8
Twin needle	8
RELATIVE CHART OF SEWING MATERIAL, NEEDLE AND THREAD .	9
SEW-LIGHT.	9
Sew light switch button	9
How to change the light bulb	9
UPPER (NEEDLE) THREAD.	10
LOWER (BOBBIN) THREAD.	11
How to wind bobbin	11
How to remove and insert bobbin case	12
How to thread bobbin case	12
How to pull up lower thread.	13
FREE-ARM SEWING	13
THREAD TENSION	14
Upper thread tension	14
Lower thread tension.	14
PRESSURE ADJUSTER.	16

2	Straight Stitching	17
----------	---------------------------	-----------

How to start sewing.	17
How to change sewing direction.	17
How to finish your sewing project	18
How to remove final sewing from machine	18
How to sew very thin material.	18
How to guide your material	18

3	Zigzag Stitching	19
----------	-------------------------	-----------

Simple zigzag stitch.	19
Satin stitch.	19

4	Decorative Stitches	20
----------	----------------------------	-----------

5	Buttonholes and Button Sewing	21
----------	--------------------------------------	-----------

Buttonholes	21
Button sewing.	23

6	Making Various Stitches	24
----------	--------------------------------	-----------

Zipper insertion.	24
Gathering	24
Darning.	25
Attaching lace.	25
Appliqueing	26
Cording.	26
Blind stitch	27
Overlock	27
Monogramming and embroidering using embroidery hoop.	28

7	Maintenance and Care of Your Machine	29
----------	---	-----------

Cleaning	29
How to oil sewing machine	30
Check list for better sewing	32
Repacking the machine.	33
Index	34

1

Knowing Your Sewing Machine

Principal Parts

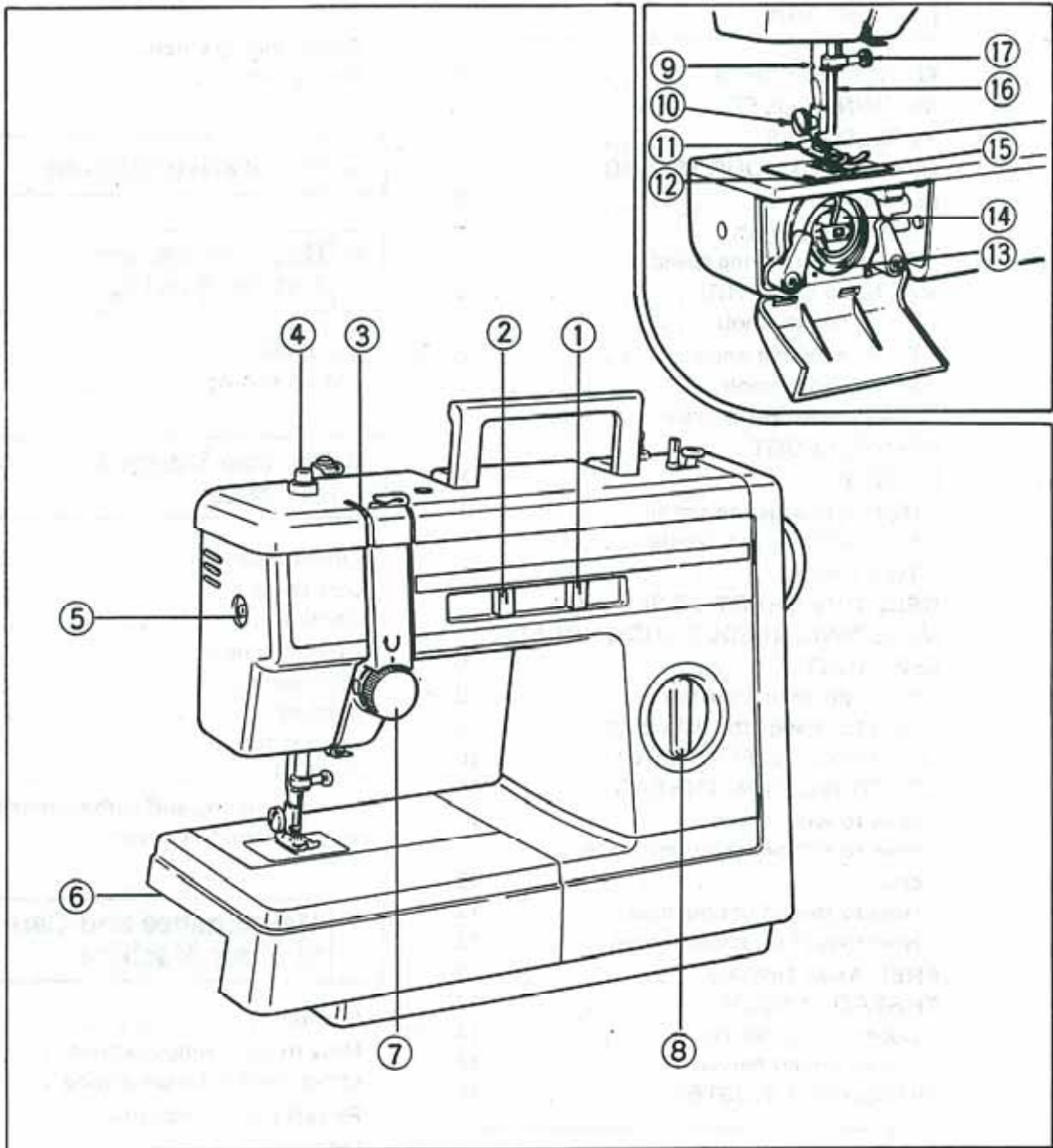

1. Needle Position Selector
2. Stitch Width Knob
3. Thread Take-up Lever
4. Pressure Adjuster
5. Sew-light Switch
6. Extension Table
7. Upper Thread Tension Dial
8. Stitch Length & Reverse Sewing Knob

9. Thread Cutter
10. Presser Foot Screw
11. Presser Foot (Zigzag)
12. Needle Plate (Zigzag)
13. Shuttle Hook
14. Bobbin Case
15. Feed Dog
16. Needle
17. Needle Clamp Screw

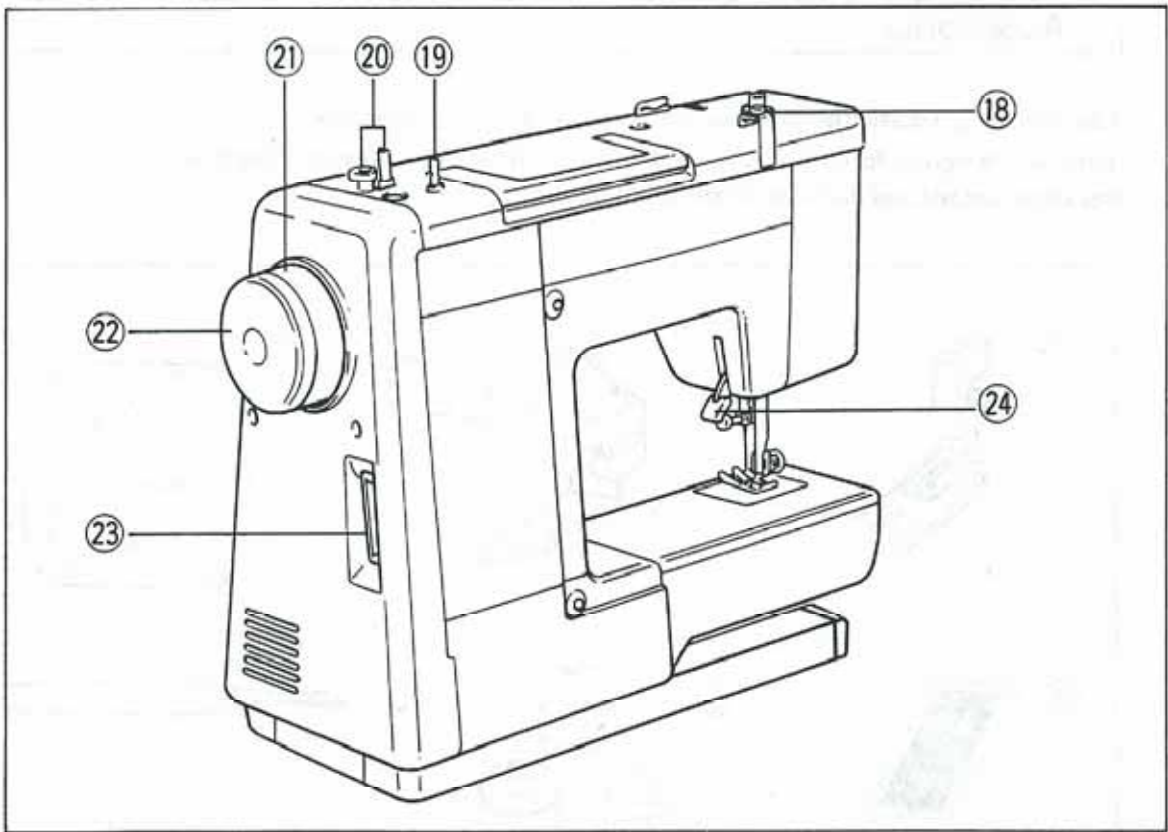

- | | |
|--|-------------------------|
| 18. Thread Guide and Bobbin Winder Disc. | 22. Stop Motion Knob |
| 19. Spool Pin | 23. 3-prong Socket |
| 20. Bobbin Winder Device | 24. Presser Foot Lifter |
| 21. Balance Wheel | |

Machine Cover

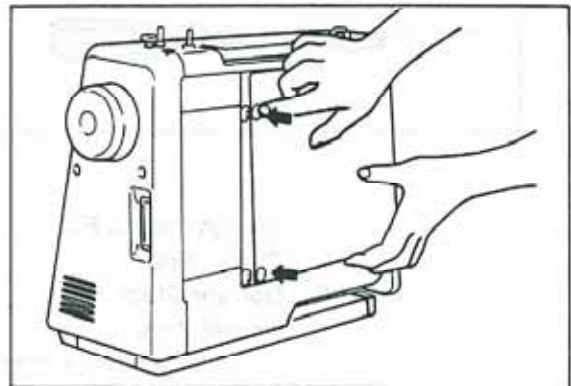
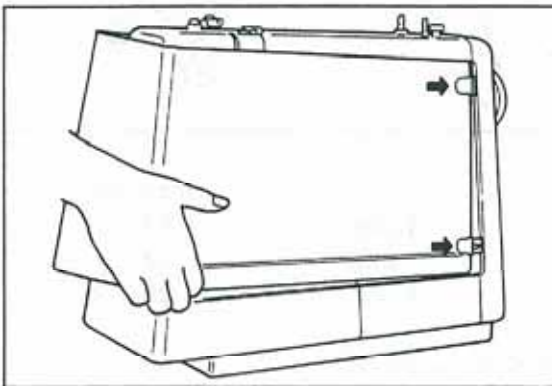

You may find machine cover in shipping box. For dust free storage, suggest you place this cover after your job.

1. Lower the presser foot and press the spool pin into machine.
2. Place the foot controller on the machine bed.
3. For front side of machine, insert two tabs into machine as illustrated.
4. Then for back side, button up at back of machine with two hook buttons as illustrated.

Accessories

The following accessories are provided with your sewing machine.

They are designed to help you do many kinds of sewing easily and perfectly.

For more details, see each page listed.

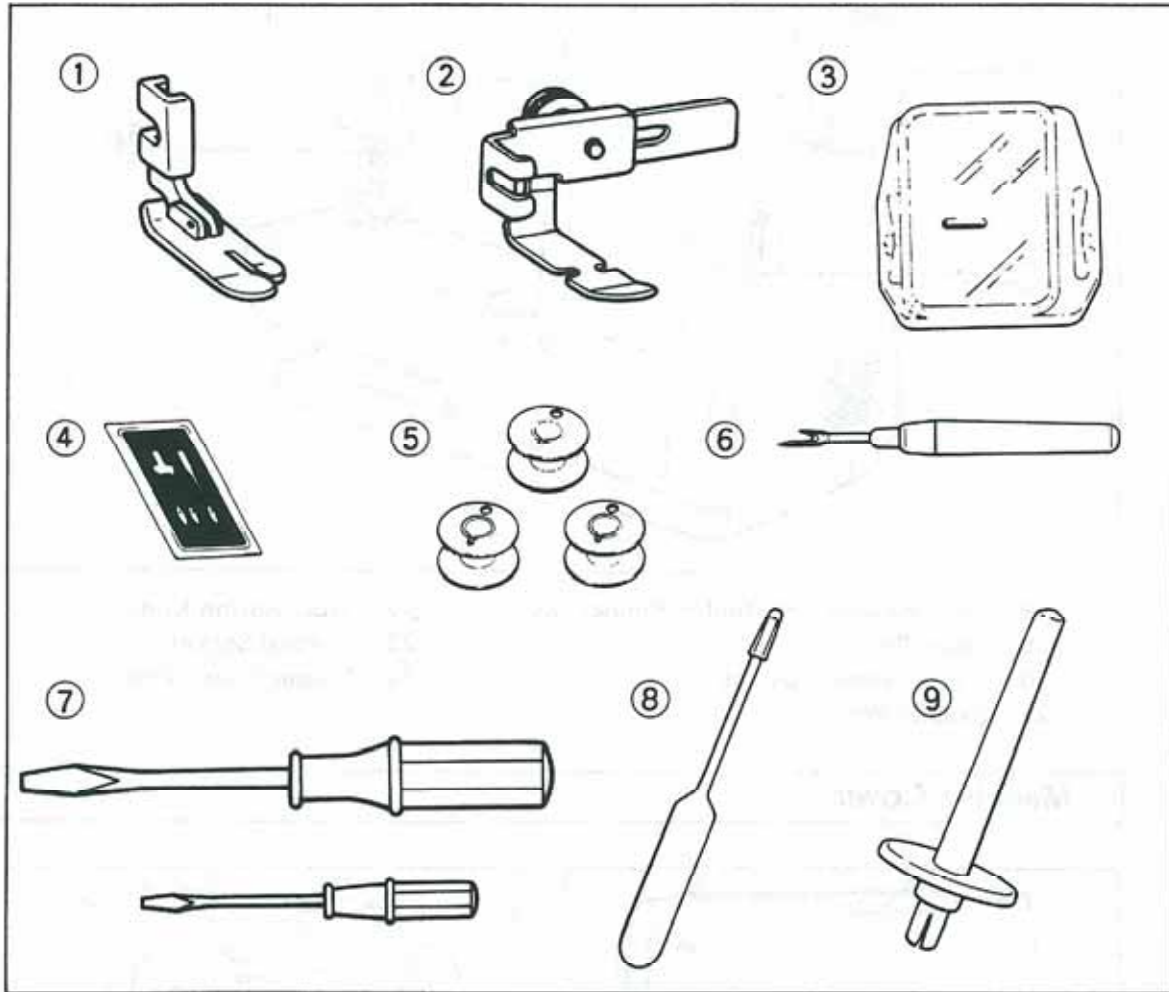

		See page
1. Straight Stitch Foot	1 pce.	17
2. Zipper Foot	1 pce.	24
3. Darning Plate	1 pce.	25
4. Needle Pack		
(Regular Single Needle No. 14 3 pcs.)		8
(Twin Needle 1 pce.)		
5. Bobbins	3 pcs.	11
6. Seam Ripper	1 pce.	22
7. Screwdriver (Large & Small)	2 pcs.	14 & 31
8. Oiler	1 pce.	30
9. Extra Spool Pin	1 pce.	8

Operating Your Sewing Machine

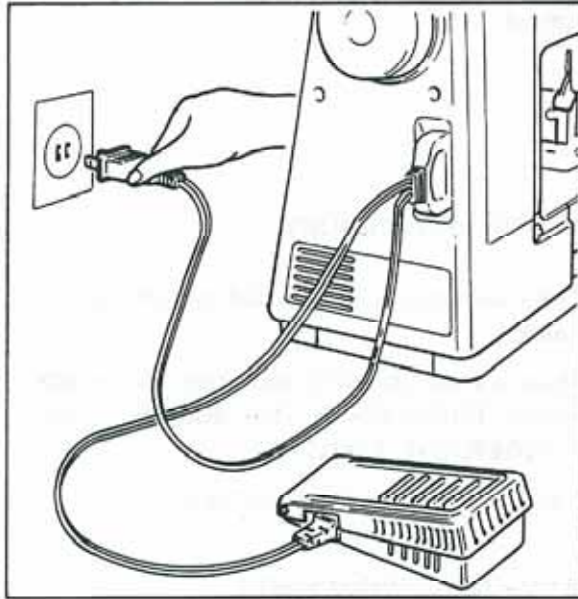

CONNECTING PLUGS

1. First connect the three-prong plug into the machine.
2. Then connect the electric supply plug into a wall outlet.

Caution

When changing needle, bobbin or light bulb, or when sewing machine is not in use, it is recommended that electrical supply plug is disconnected to avoid electrical hazards.

Remark:

The illustration on this page depicting the use of two pin plug is not applicable to use in U.K.

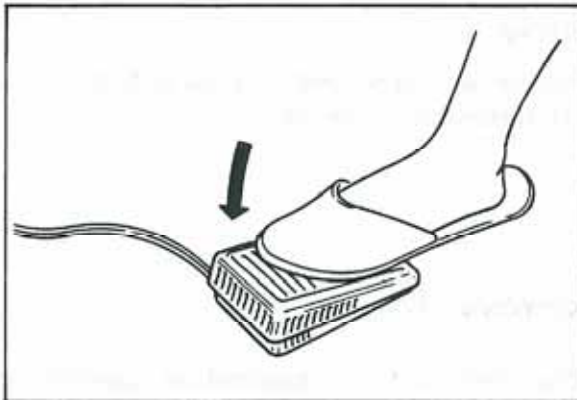

CONTROLLING SEWING SPEED

Place foot on foot control as shown in illustration.

When foot control is pushed down lightly, machine will run at a low speed.

When pressure on foot control is increased, machine will pick up speed.

When foot control is released, machine will stop.

NOTE:

1. Care should be taken that nothing is placed on foot controller when machine is not in use.
2. A new sewing machine or one that has not been in use for a long period of time should be oiled as per instruction on page 30 & 31. After oiling, be sure to wipe up any excess oil.

Various Control

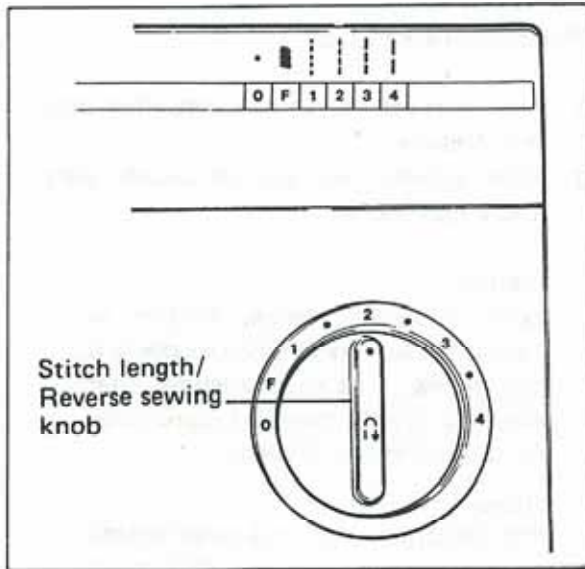

STITCH LENGTH/REVERSE SEWING KNOB

STITCH LENGTH KNOB

The stitch length is regulated by turning this knob.

Numbers on the ring represent the stitch length. THE HIGHER THE NUMBER, THE LONGER THE STITCH.

The "0" means that material is not fed.

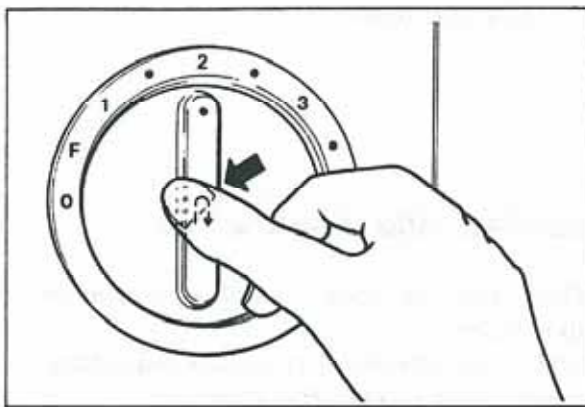

REVERSE SEWING KNOB

To sew in reverse, push this knob as far as it will go and keep it in this position until you wish to sew forward.

When you release, it springs back for forward sewing.

Reverse sewing is used for back tacking and reinforcement of the seam.

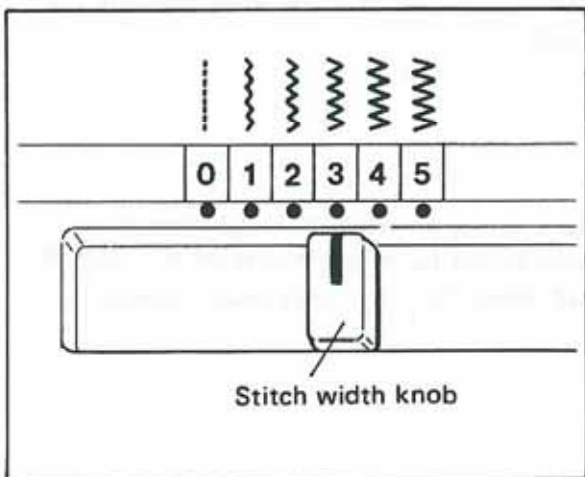

STITCH WIDTH KNOB

The zigzag width is regulated by operating the stitch knob.

Numbers above the knob represent the width of stitch. THE HIGHER THE NUMBER, THE WIDER THE STITCH.

The "0" means straight stitch only.

- NOTE:
1. Do not move the knob while the needle is in the material.
 2. When using twin needle, knob should always be set at under "3".

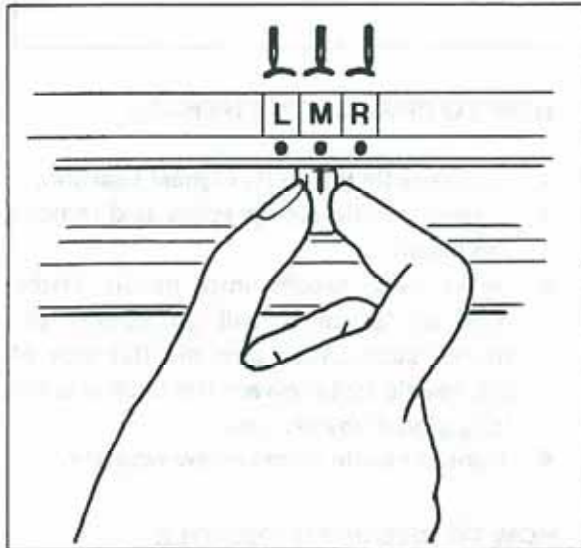

NEEDLE POSITION SELECTOR

By shifting this lever to L (left), M (middle) or R (right), you will be able to sew straight and zigzag stitches as the base line.

When you sew close to the edge of material, select L or R so that you can obtain better feeding of the material.

For almost all stitching, this selector to be set at M (middle) but set other position for following application.

1. Buttonhole (page 21)
2. Button sewing (page 23)
3. Decorative stitches (page 20)

NOTE: 1. Do not move the selector while needle is in the material.
2. Set the selector always at M when you use twin needle.

Presser Foot

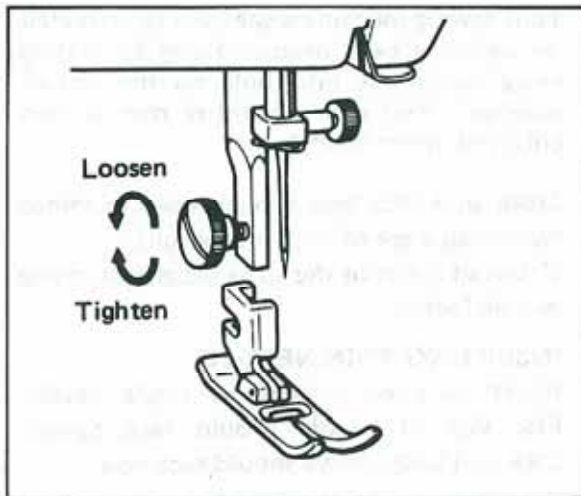

You will find various kinds of presser foot for special use in the extension table. According to your sewing needs, it may be necessary to change presser foot.

CHANGING THE PRESSER FOOT

1. Raise needle to its highest position and raise presser foot lifter.
2. Loosen presser foot thumb screw and remove presser foot.
3. Place grooved side of the new presser foot against the flat of the presser bar.
4. Tighten thumb screw securely.

Needle

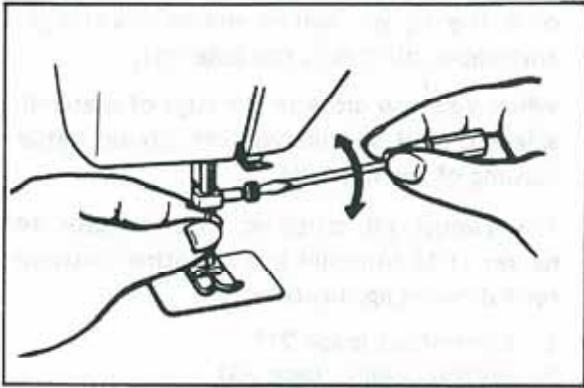

HOW TO CHANGE THE NEEDLE

1. Raise needle bar to its highest position.
2. Loosen needle clamp screw and remove old needle.
3. Insert new needle into needle clamp hole as far as it will go against the needle stop. Make sure the flat side of the needle faces toward the back and the long groove toward you.
4. Tighten needle clamp screw securely.

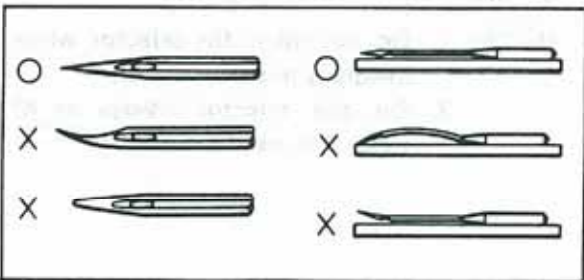

HOW TO CHECK THE NEEDLE

1. The sewing needle must always be straight and sharp for smooth sewing.
2. To check if needle is bent, place flat side of needle down as shown in illustration at left.

Twin Needle

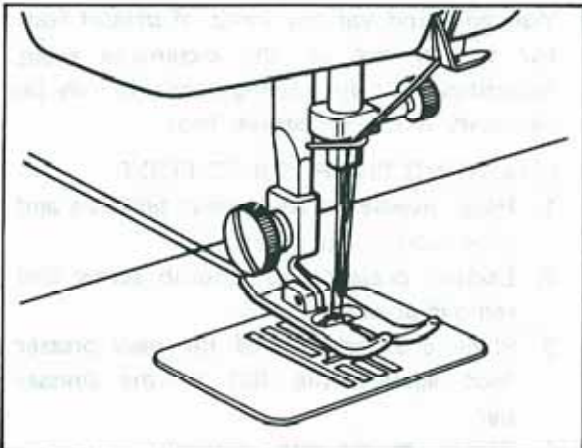

Your sewing machine is specially constructed for optional twin needle sewing by setting extra spool pin into hole on the top of machine. You can use either one or two colors of upper thread.

Make sure that two threads used to thread twin needle are of the same weight. If thread is not of the same weight, stitching will be faulty.

INSERTING TWIN NEEDLE

Insert in same manner as single needle. Flat side of needle should face toward back and long groove should face you.

THREADING TWIN NEEDLE

Follow instructions for single needle threading (see page 10), but thread each needle separately. The groove should face you.

NOTE FOR TWIN NEEDLE SEWING

1. Use ZIGZAG PRESSER FOOT.
2. Use stitch width knob at under "3".
3. Needle position selector "M".

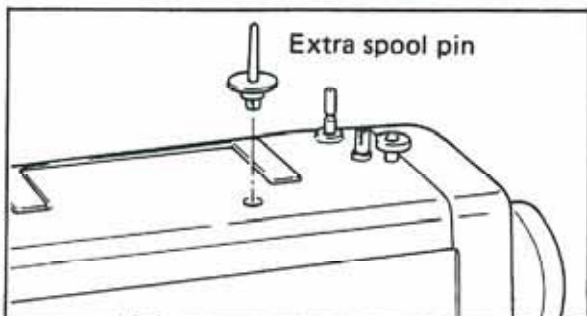

Relative Chart of Sewing Material, Needle and Thread

SEWING MATERIALS		NEEDLE SIZES	THREAD SIZES
VERY THIN	Fine tricot, Fine lace, Thin linen, Silk, Tulle, Chiffon	9	Cotton: 80-120 Synthetic Fine Mercerized Cotton
LIGHTWEIGHT	Organdy, Jersey, Voile, Taffeta, Synthetics, Silk, Batiste	11	Cotton: 60-80 Silk: "A" Synthetic Mercerized 50
MEDIUM	Cotton, Gingham, Poplin, Percale, Pique, Satin, Velvet, Lightweight wool Fine corduroy, Suitings	14	Cotton: 50-60 Silk: "A" Synthetic Mercerized 50-60
HEAVY	Denim, Gabardine, Tweed, Corduroy	16	Cotton: 40-50 Mercerized Heavy-Duty
VERY HEAVY	Canvas, Overcoating, Upholstery	18	Cotton: 30-40 Mercerized Heavy-Duty

- NOTE: 1. Select correct size of needle and thread from above chart.
2. Use the same size thread for upper and lower threads.

Sew-light

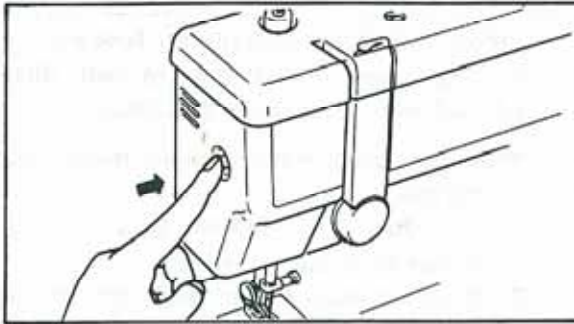

SEW LIGHT SWITCH BUTTON

To switch the light on or off, push the sew-light switch button.

HOW TO CHANGE THE LIGHT BULB

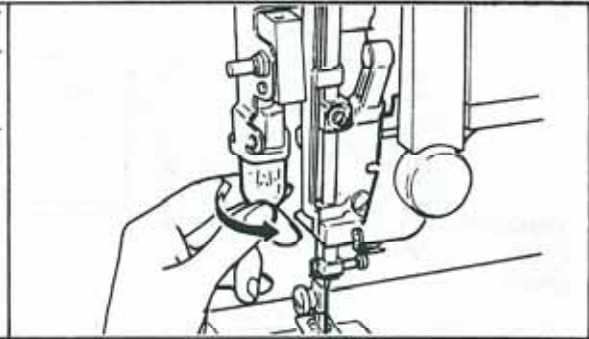
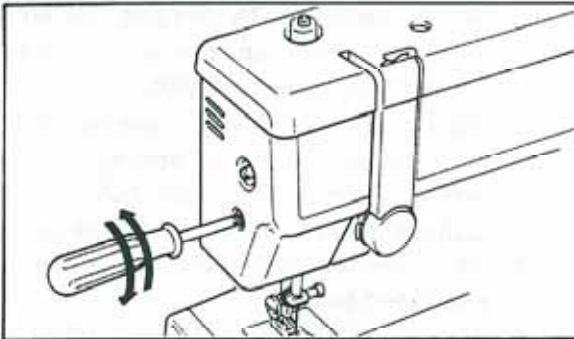

1. Remove face plate by loosening a screw on face plate.
2. Remove light bulb by turning it counterclockwise.
3. Replace light bulb and fix face plate.

NOTE: 1) Make sure to disconnect electric supply plug from wall outlet before changing light bulb.

- 2) Always use **CORRECT LIGHT BULB.**
MAXIMUM INPUT OF LAMP

12W.110/115V AREA
15W.220/240V AREA

Upper (Needle) Thread

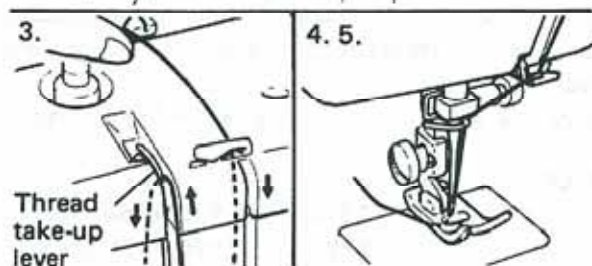
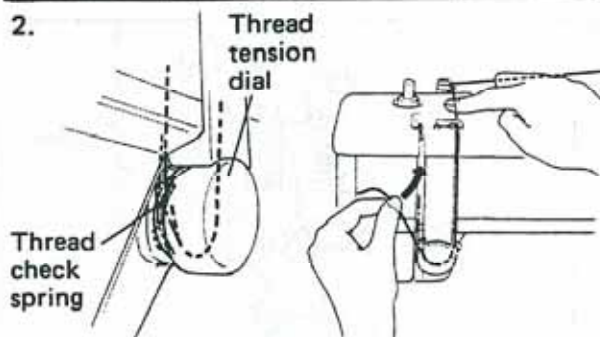
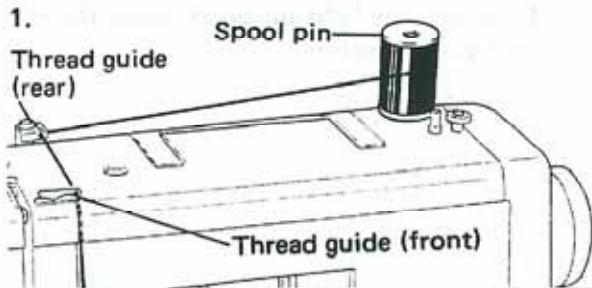
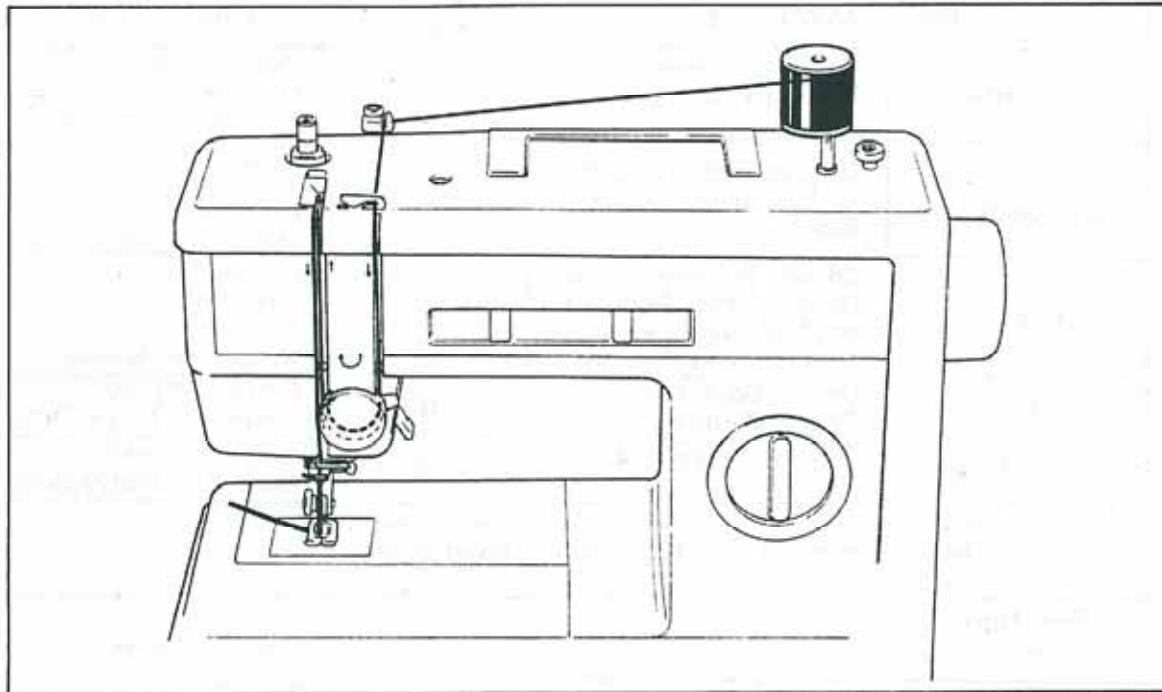

Before threading, raise presser foot and turn balance wheel toward you to raise thread take-up lever to its highest position.

Then raise spool pin and place thread spool on the pin.

1. Pass thread through the both of thread guides from rear to front.
2. Bring thread down and up through upper thread tension dial from right to left so that thread picks up the thread check spring. With holding thread as illustrated, *pull up thread and deliver into the eye in tension disc.*
3. Thread take-up lever by guiding thread to back of lever and around to your left. Bring thread through slit by pulling it toward you and into eyelet.
4. Bring down and pass through the thread guard and guides.
5. Thread needle from front to back and draw the thread out about 2 inches (5 cm).

NOTE:

IF THE THREADING ORDER IS NOT CORRECT, THREAD BREAKAGE, STITCH SKIPPING AND WRINKLING OF FABRIC WILL OCCUR.

Lower (Bobbin) Thread

HOW TO WIND BOBBIN

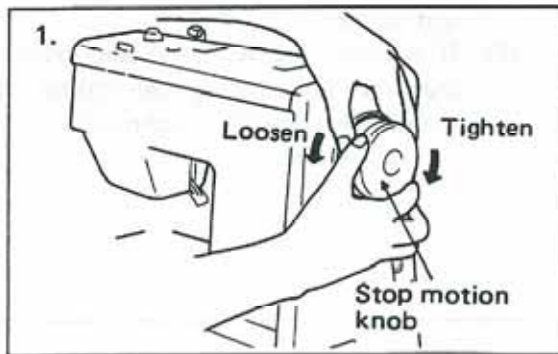
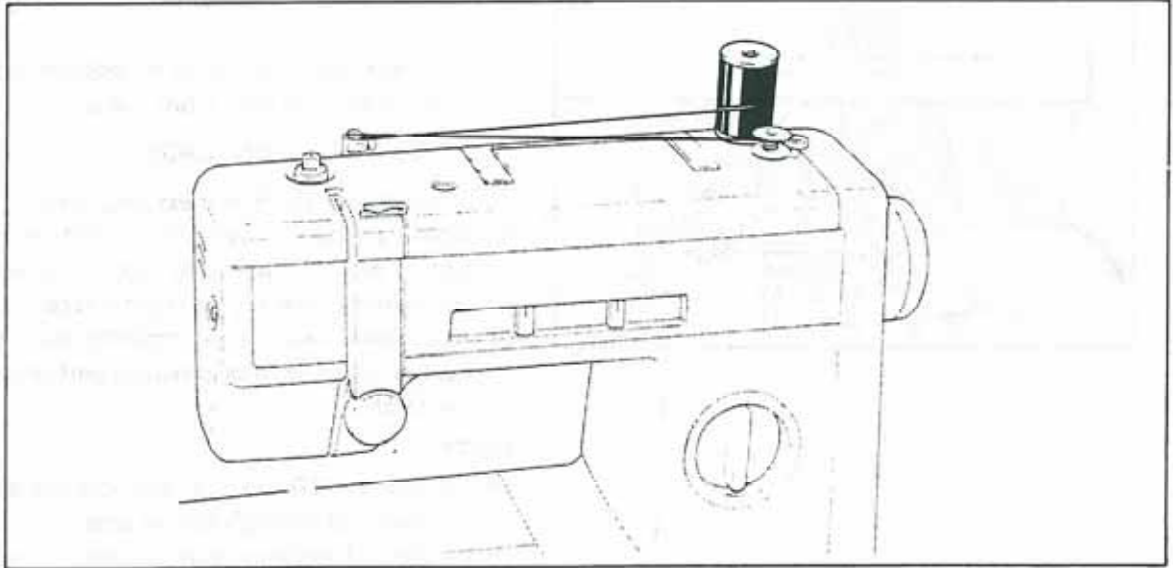

1. Loosen stop motion knob by turning it toward you.

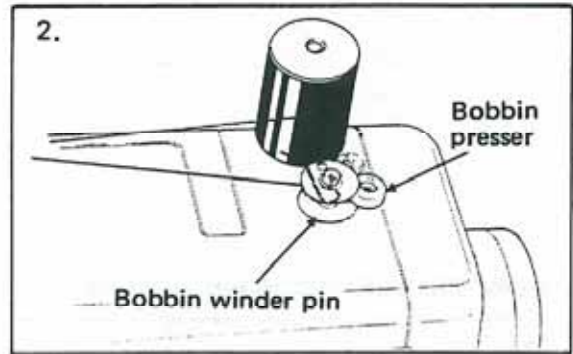

2. Place an empty bobbin on the bobbin winder pin.

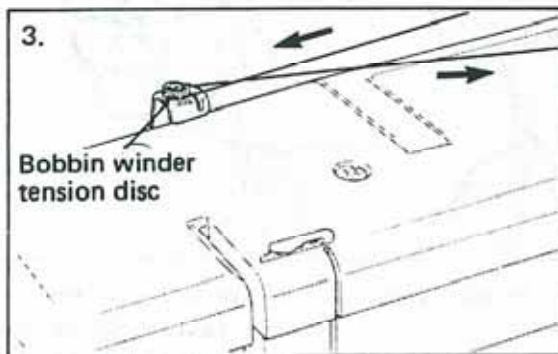

3. Place thread spool on the spool pin and take thread through bobbin winder tension disc.

4. Wind the thread a few times around the bobbin clockwise and push the bobbin toward bobbin presser. Start the machine gently.
5. Bobbin stops winding when full.
6. Push the bobbin to the left and remove it. Tighten stop motion knob securely.

HOW TO REMOVE AND INSERT BOBBIN CASE

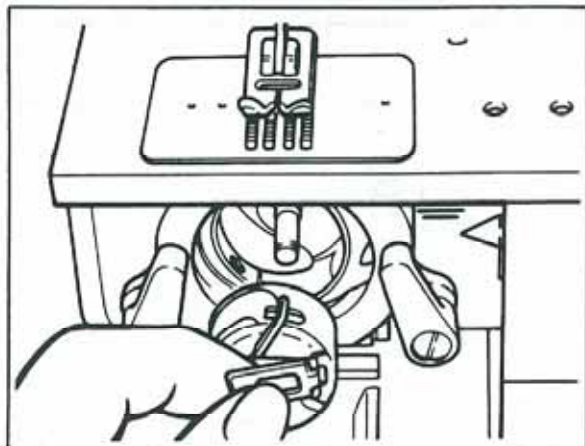

TO REMOVE BOBBIN CASE

1. Raise needle to its highest position.
2. Open the shuttle cover by turning it down.
3. Pull and open the latch of bobbin case.
4. Pull out bobbin case from the shuttle.

TO INSERT BOBBIN CASE

1. Raise needle to its highest position.
2. Holding bobbin case latch with metal finger of case pointing up, fit it into the notch at the top of shuttle race.
3. Push case back fully, making sure the case is in the proper position and release the latch.

NOTE:

- (A) 4 inches (10 cm) of thread should be drawn out and left out of case.
- (B) Latch of bobbin case should be open fully to prevent bobbin from coming out of case.
- (C) If bobbin case is not placed back in machine properly it will come out from the shuttle immediately after starting to sew.

HOW TO THREAD BOBBIN CASE

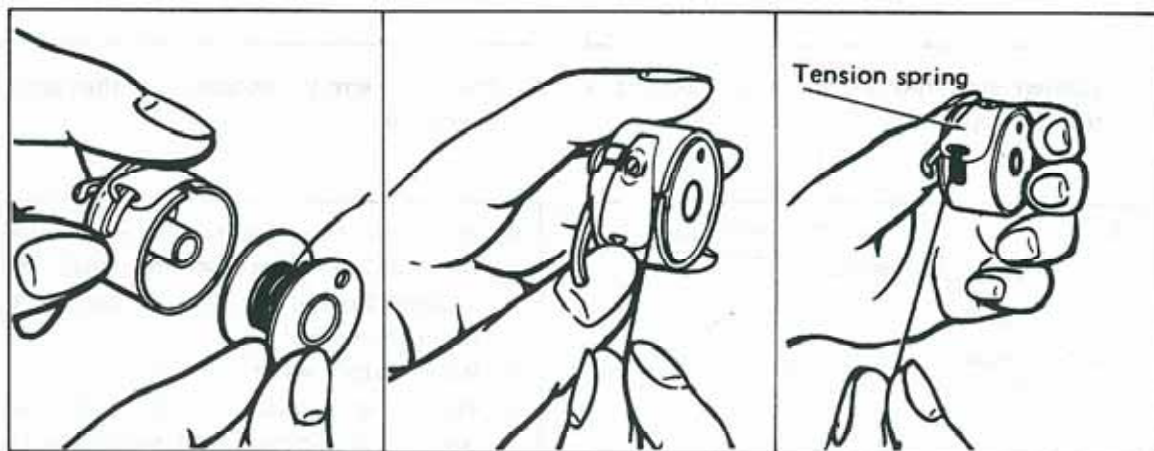

1. Unwind about 4 inches (10 cm) of thread from the bobbin. Insert wound bobbin into bobbin case.
2. Pull trailing thread into the slot of case.
3. Pull thread to the left under tension spring until thread enters into delivery eye.

HOW TO PULL UP LOWER THREAD

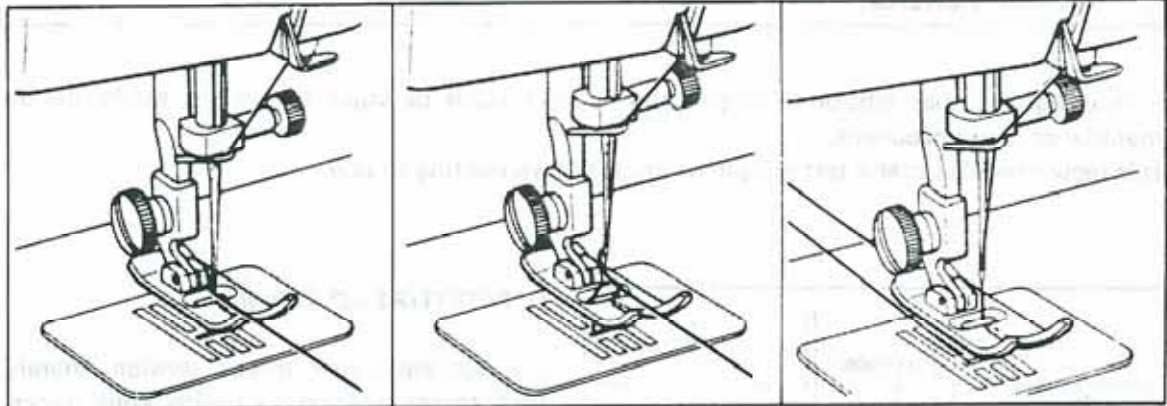

1. Raise needle and presser foot to the highest position. With left hand, hold the end of upper thread and with right hand, turn balance wheel toward you until the needle moves down and up again to its highest position.

2. Now upper thread catches the lower thread in a loop. Pull thread toward you so that lower thread will come up in a large loop from the presser foot.

3. Pull both threads under the toes of presser foot and place them to the rear leaving about 4 inches (10 cm).

Free-Arm Sewing

For sewing tubular and hard to reach garment areas, free-arm sewing is most convenient.

To make your machine a free-arm model, lift-up and slide out extension table.

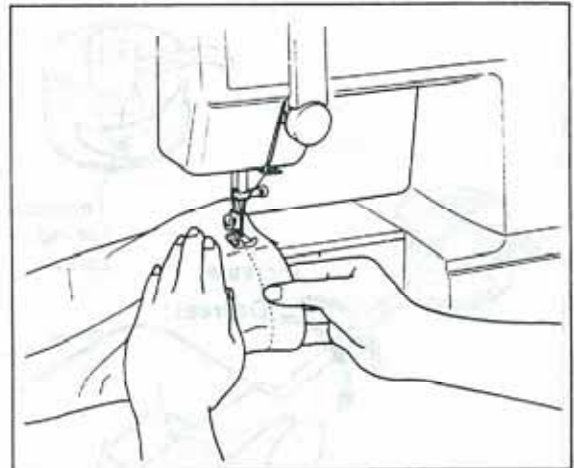
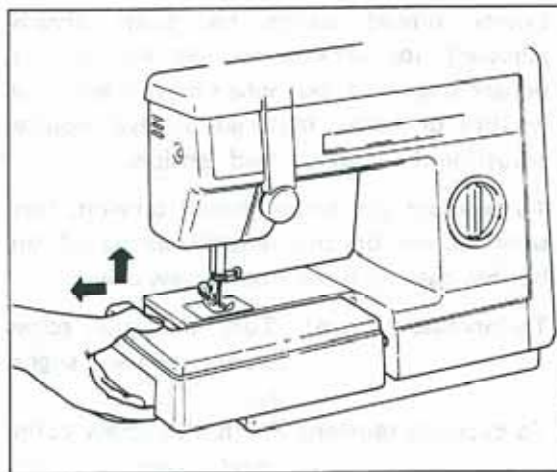

Thread Tension

It is important that tension of upper and lower threads be equal to prevent puckering of material or other problems.

It is recommended that a test sample be made before starting to sew.

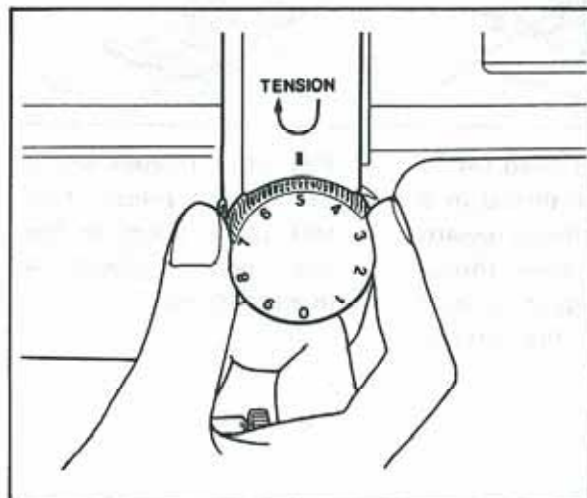

UPPER THREAD TENSION

To regulate upper thread tension, merely turn thread tension dial with your fingers after lowering the presser foot.

THE HIGHER THE NUMBER, THE TIGHTER THE TENSION.

To increase tension: Turn dial to right to higher number.

To decrease tension: Turn dial to left to lower number.

NOTE: When sewing the zigzag stitch, it requires less upper tension than straight stitch.

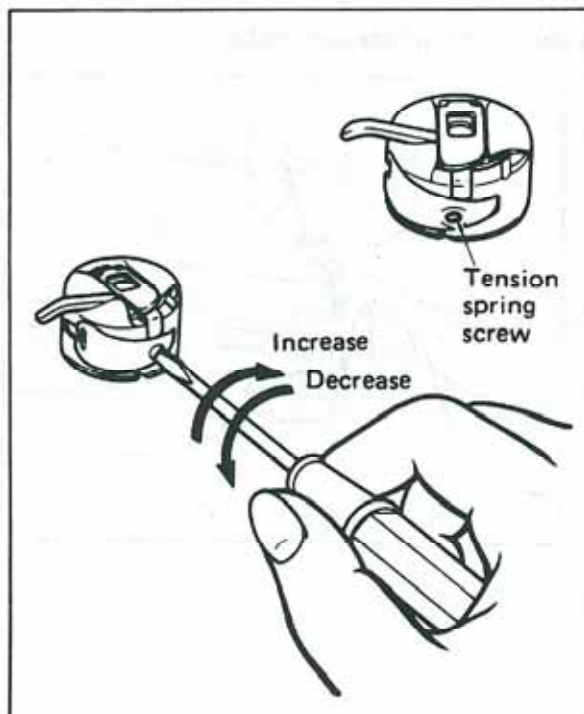

LOWER THREAD TENSION

Lower thread tension has been already adjusted for general use at the factory before shipment, but when sewing extremely thin or heavy material, it also requires adjusting the lower thread tension.

To regulate the lower thread tension, turn small screw on the tension spring of the bobbin case with the small screw driver.

To increase tension: Turn the small screw clockwise very slightly.

To decrease tension: Turn the screw counterclockwise very slightly.

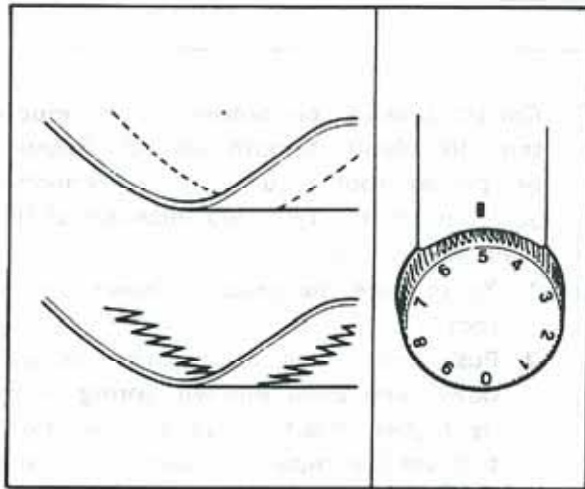

PERFECT STITCHING

The tension of the upper and lower threads should be equal and just sufficiently strong to lock both threads in the center of the work.

Perfect stitch shows flat and no puckering result on the material.

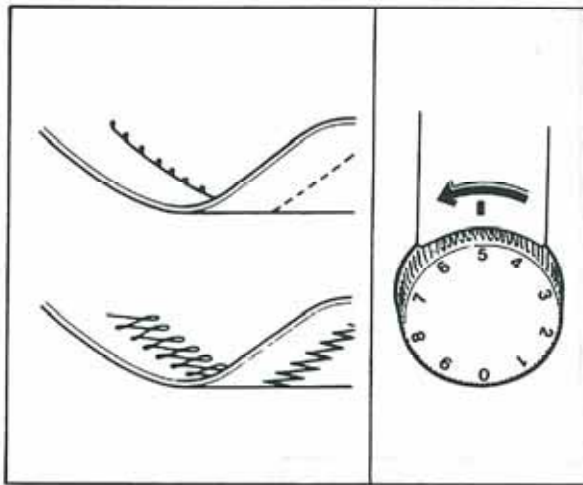

INCORRECT STITCH (A)

The upper thread lies on the surface of the material by pulling the lower thread up as shown.

This is caused by tight tension on the upper thread or loose tension on the lower thread.

To correct this, turn the upper thread tension dial to a lower number.

When perfect stitch cannot be obtained by only upper thread tension dial, adjust the bobbin tension accordingly.

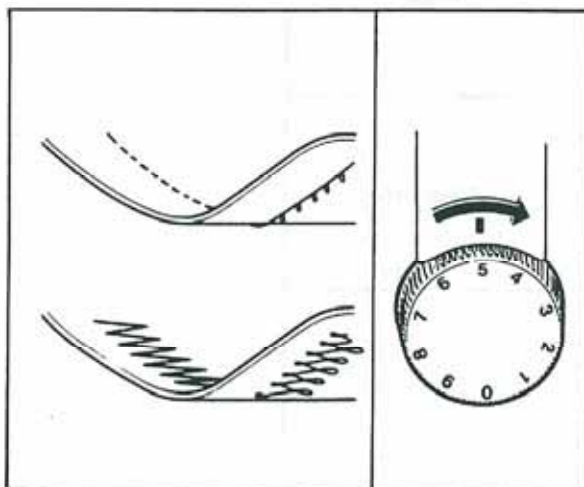

INCORRECT STITCH (B)

The lower thread lies on the under surface of the material by pulling upper thread down as shown.

This is caused by loose tension on the upper thread or tight tension on the lower thread.

To correct this, turn the upper thread tension dial to a higher number.

When perfect stitch cannot be obtained by only upper thread tension dial, adjust bobbin tension accordingly.

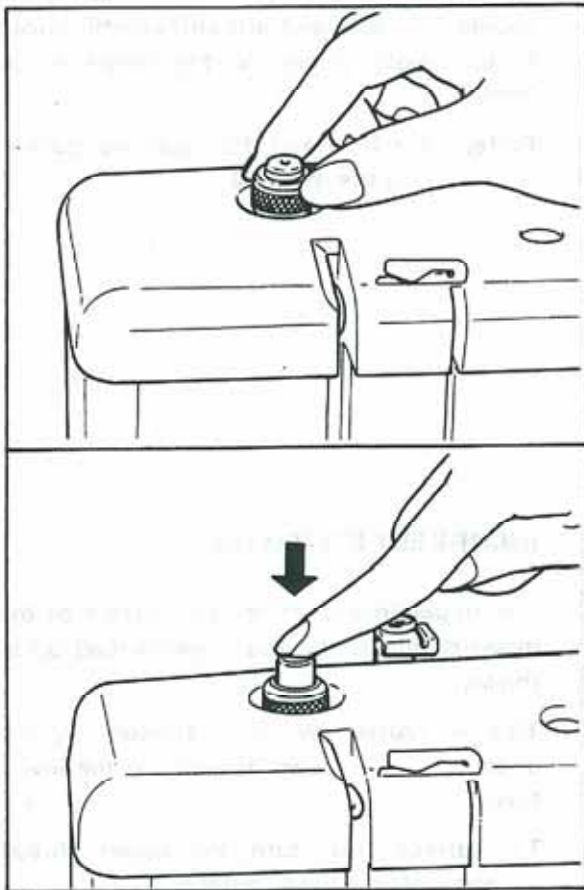

NOTE: We recommend you to make test samples before starting to sew.

Pressure Adjuster



Correct pressure on presser foot is important to obtain smooth sewing. Pressure on presser foot requires to be regulated according to the type and thickness of the material to be sewn.

1. To regulate the pressure, lower presser foot.
2. Push outer ring of pressure adjuster down, and inner pin will spring up to its highest position. In this position, pressure is completely released from the presser foot.
3. To increase pressure, push inner pin down with your finger.

Pressure Adjuster	Sewing Purpose	Pressure on Foot
 UP	Darning Embroidering Monogramming	Free
 MIDDLE	Mending Normal use and lighter material such as silk and nylon	Medium
 DOWN	Thick and heavier materials	Heavy

STITCH LENGTH	: F ~ 4
STITCH WIDTH	: 0
NEEDLE POSITION	: M. L. R. (Twin needle sewing, always set at M)
PRESSER FOOT	: Straight or Zigzag
NEEDLE	: Single
PRESSURE ADJUSTER	: According to the material

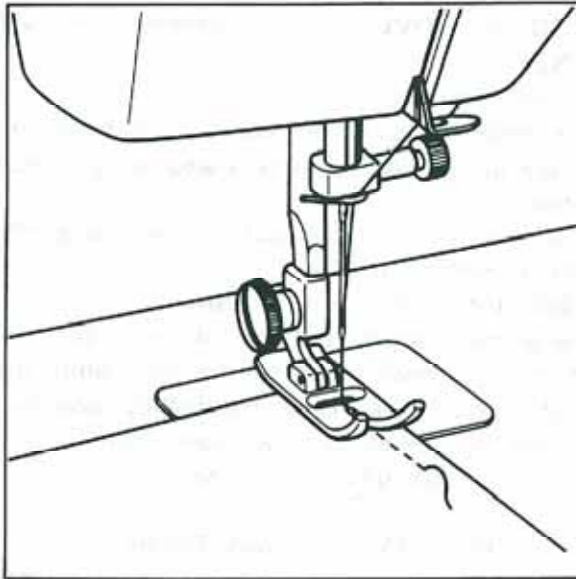

HOW TO START SEWING

1. Raise needle to its highest position and lift presser foot.
2. Pull up lower thread by turning the balance wheel toward you and place both upper and lower thread to the left.
3. Place material under presser foot and position needle 3/8 inch (1 cm) from material edge.
4. Lower presser foot.
5. For reverse sewing, push reverse sewing knob as far as it will allow. Reverse sewing is used where reinforcement is needed.
6. Release reverse sewing knob and start sewing in forward direction.

NOTE: Use straight stitch foot when sewing light or elastic type materials with straight stitch.

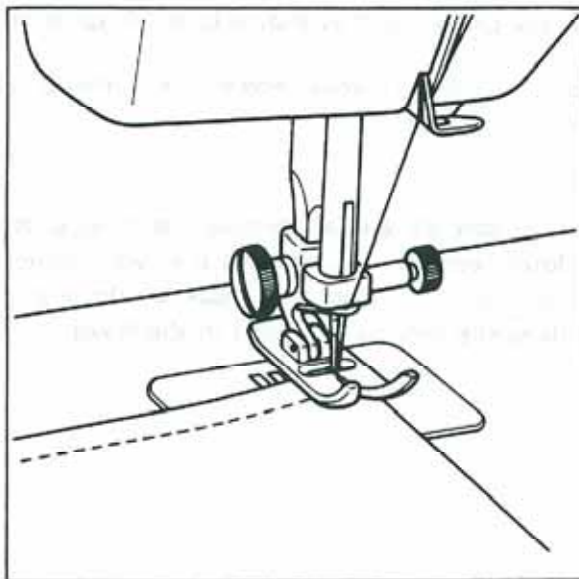

HOW TO CHANGE SEWING DIRECTION

1. Stop machine at the turning point while the needle is in the material.
2. Raise the presser foot and turn the material to the new direction while the needle acts as the axis.
3. Lower the presser foot and start sewing in new direction.

NOTE: In case of twin needle sewing, raise the needle at the turning point.

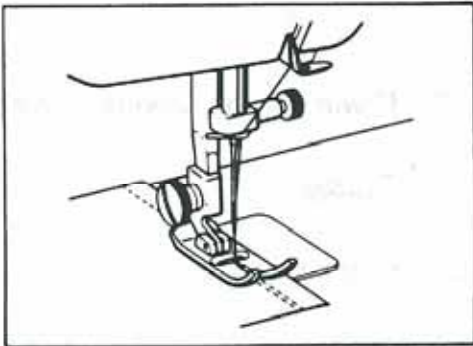

HOW TO FINISH YOUR SEWING PROJECT (REVERSE STITCHING)

Reverse stitching is used to reinforce stitches near the edge of material or wherever reinforcement is needed.

1. This is done by stitching to the edge of material then stopping.
2. Push reverse knob and stitch backwards for 3/8 inch (1 cm) from material edge.

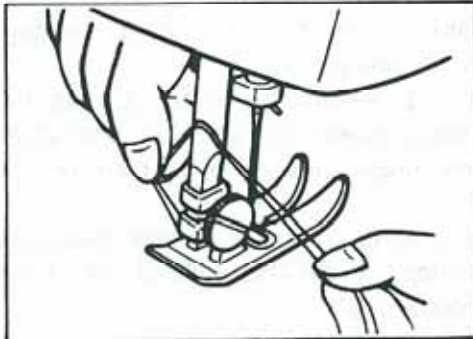

HOW TO REMOVE FINAL SEWING FROM MACHINE

1. Stop the machine.
2. Raise needle to its highest position and make sure that the thread take-up lever is also to its highest position.
3. Lift presser foot and pull out the material gently to the left side diagonally.
4. Cut both threads on the thread cutter.
5. Leave about 4 inches (10 cm) of thread between toes of the presser foot to the rear while the thread take-up lever is at the highest position, and you are ready to sew again without any chance of thread pulling out of the needle.

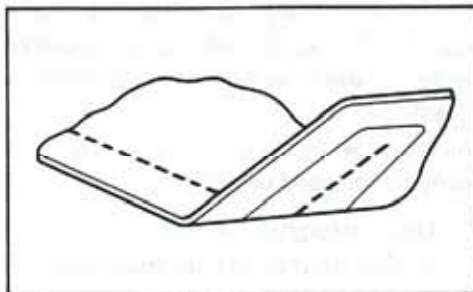

HOW TO SEW VERY THIN MATERIAL

An underlay of thin paper will help to eliminate skipped stitches and puckering on very thin material.

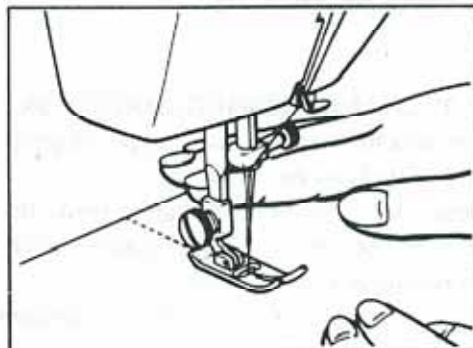

HOW TO GUIDE YOUR MATERIAL

Do not pull the material. Let the machine do the work. Merely guide the material with your fingers in front of the presser foot as shown in the illustration.

If you pull the material, your needle might either bend or break.

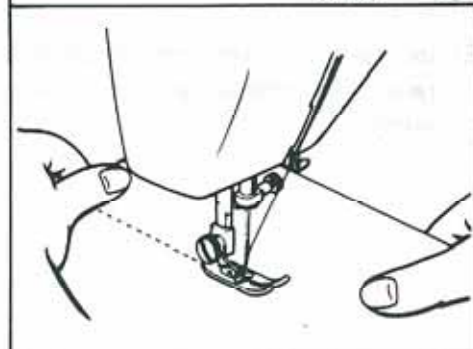

However, in case of special materials, such as tricot, crepes, knits, etc., we recommend that you support the material both in front and back of the presser foot with gentle tension as shown in the lower illustration.

STITCH LENGTH	:	1 ~ 4 (For SATIN STITCH, set at F)
STITCH WIDTH	:	1 ~ 5 (Twin needle sewing, always set at 3)
NEEDLE POSITION	:	M. L. R. (Twin needle sewing, always set at M)
PRESSER FOOT	:	Zigzag
NEEDLE	:	Single or Twin Needle
PRESSURE ADJUSTER	:	According to the material

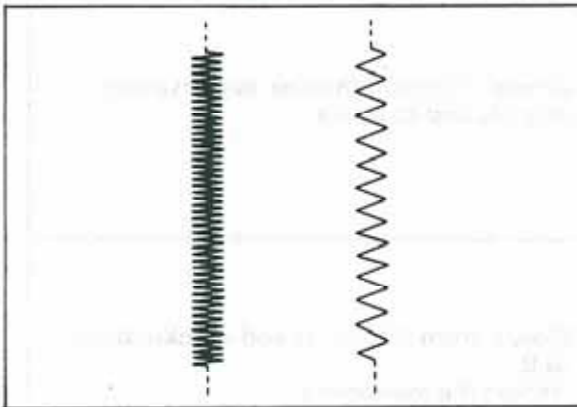
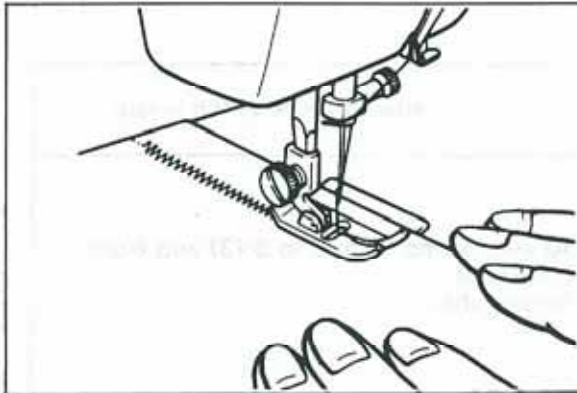
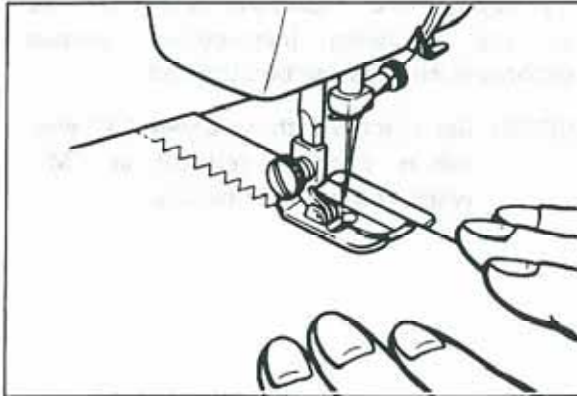

SIMPLE ZIGZAG STITCH

Set stitch length between 1-4 for simple zigzag stitch.

1. With stitch length to between 0-1 sew 5-6 *straight* stitches for reinforcement.
2. Set stitch width to your desired width and begin sewing.
3. Reset stitch width to "0" and set stitch length to between 0-1 to again reinforce stitches before removing work from machine.

NOTE: Zigzag stitching requires less upper thread tension than straight stitching.

SATIN STITCH

When stitch length is set between 0-1, it produces the "SATIN STITCH" which is used for making fine buttonholes or decorative stitches.

NOTE: It is recommended that a *test sample* be made before starting to sew.

Decorative Stitches

STITCH LENGTH	:	For SATIN STITCH set dial to between 0 ~ 1 (F)
STITCH WIDTH	:	
NEEDLE POSITION	:	See Instruction Below
PRESSER FOOT	:	M. L. R.
NEEDLE	:	Zigzag
PRESSURE ADJUSTER	:	Single or Twin Needle
	:	According to the material

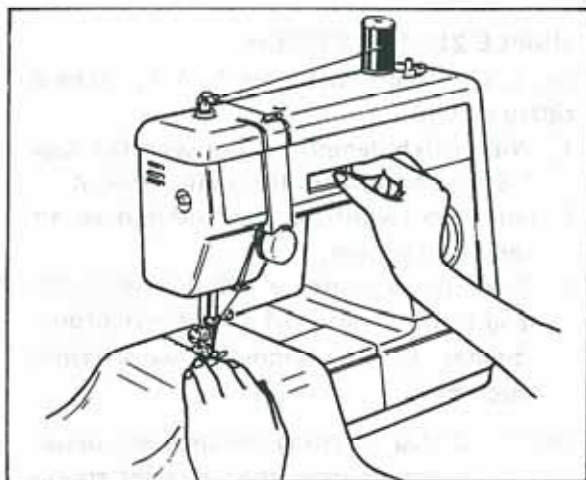

By using the "SATIN STITCH" as in the following instructions, various decorative stitches can be obtained.

NOTE: Set stitch width at under "3" and needle position selector at "M" when you use twin needle.

Needle	Needle position	Patterns to be sewn	How to move stitch width
Single needle	L M R		At even speed from 0 to 5 (3) and from 5 (3) to 0. Repeat this.
Twin needle	M		
Single needle	L M R		Almost the same manner as above but make round patterns.
Twin needle	M		
Single needle	L M R-		Slowly from 0 to 5 (3) and quickly back to 0. Repeat the movement.
Twin needle	M		

* NOTE: The number in the bracket represents the twin needle sewing.

Buttonholes

STITCH LENGTH	: For SATIN STITCH set dial to between 0 ~ 1 (F)
STITCH WIDTH	: See Instruction Below
NEEDLE POSITION	: R (Right Position)
PRESSER FOOT	: Zigzag
NEEDLE	: Single
PRESSURE ADJUSTER	: According to the material

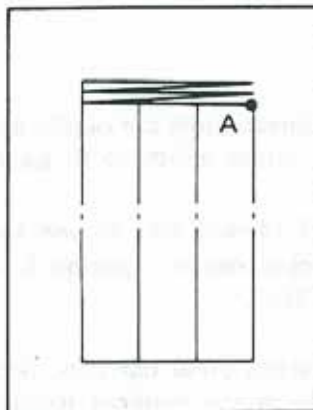

PROCEDURE FOR MAKING BUTTONHOLE

Step A: Bar Tack

1. Set stitch width at "5" and needle position at "R".
2. Lower presser foot and sew 2 to 3 stitches.
3. Stop the machine when the needle is in the material at the right side of stitches. (Position A)

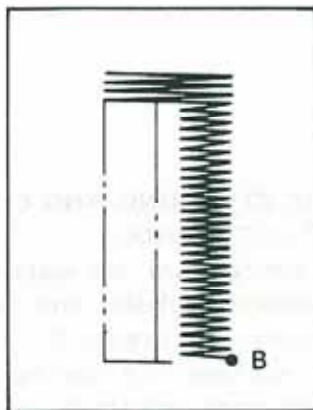

Step B: Right Row

1. Set stitch width at "2".
2. Sew predetermined length.
3. Stop the machine when the needle is in the material at the right side of stitches. (Position B)

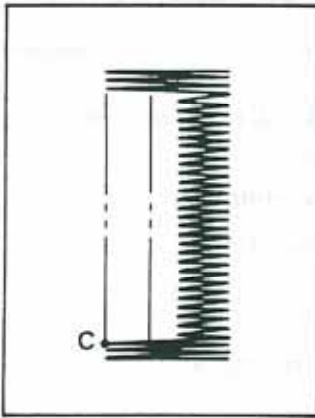

Step C: Final Bar Tack

1. Set stitch width at "5".
2. Sew 2 to 3 stitches.
3. Stop the machine when the needle is in the material at the left side of stitches. (Position C)

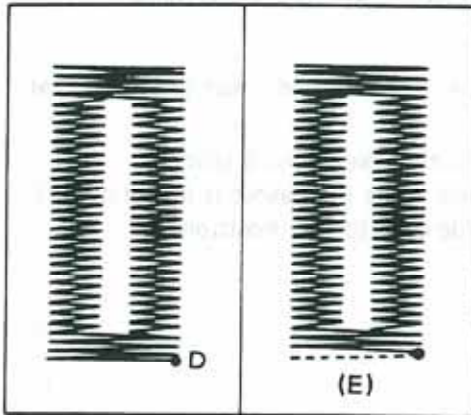

Step D: Left Row

1. Lift presser foot.
2. Turn the material 180 degrees while the needle acts as the axis and set the stitch width to 0. Lower the presser foot.
3. Turn the balance wheel toward you to sew one stitch. This action changes needle position from left to right. Lift presser foot.
4. Set stitch width at "2".
5. Sew row until needle reaches other bar tack. Stop the machine with needle in the material to right of stitches. (Position D)

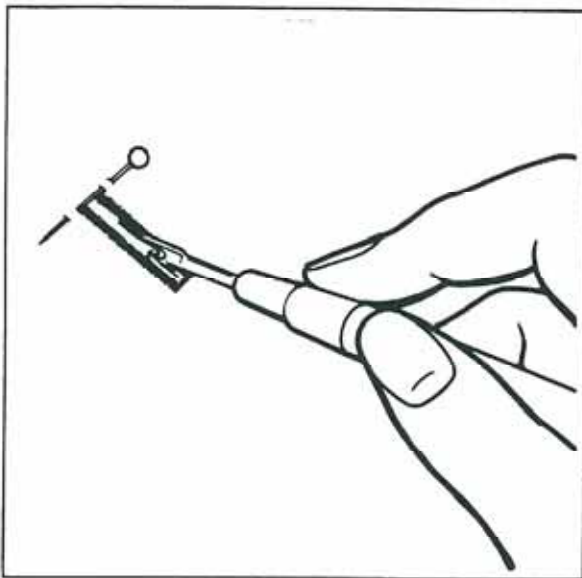

HOW TO SECURE STITCHING AND CUT MATERIAL FOR BUTTONHOLE.

1. To secure stitching, turn the material 90 degrees counter-clockwise and sew 5-6 *straight* stitches. (Illustration E)
2. Remove from machine. Cut opening in buttonhole with seam ripper tool, taking care not to cut through any stitching.
3. It is recommended that pins are placed across both ends of buttonhole as protection against cutting bar tack stitching.

- NOTE: 1. We suggest a *test SAMPLE* be made, before actual sewing.
2. Use of tailors' chalk to mark length of buttonhole on material is recommended.

Button Sewing

STITCH LENGTH	:	0
STITCH WIDTH	:	According to the distance of holes
NEEDLE POSITION	:	L or R
PRESSER FOOT	:	Zigzag
NEEDLE	:	Single
PRESSURE ADJUSTER	:	Middle

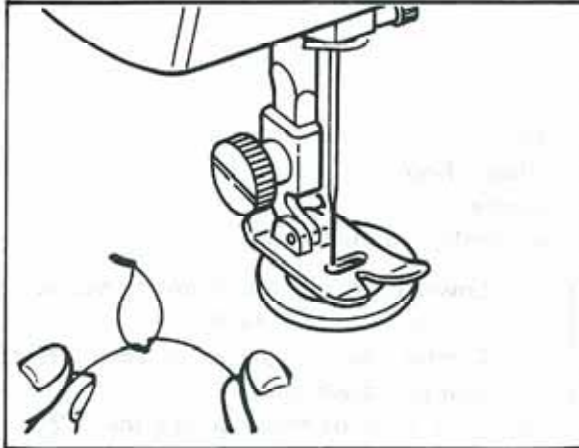

1. Place button between the presser foot and material.
2. Control zigzag width to suit the distance of the holes of button.
3. Lower the presser foot and check if the needle enters into both holes of button without any obstruction.
4. Slowly sew about 10 stitches.
5. Stop machine and raise needle from the material.
6. Remove from machine. Cut upper and lower threads and with normal sewing needle, sew threads through to back of button and tie.

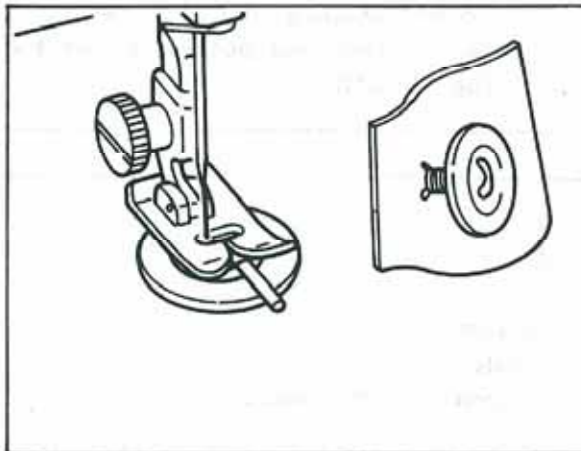

BUTTON FITTING WITH THREAD SHANK

You will often need the thread shank of button for heavier materials.

1. Place a needle on the button as illustrated and sew as regular method of button fitting.
2. After about 10 stitches, remove the fabric from the machine, leaving upper thread little longer in order to form a thread shank.
3. Pull upper thread between the button and the material through the hole of button and upper thread tightly around the stitches.
4. Fasten the thread ends.

Zipper Insertion

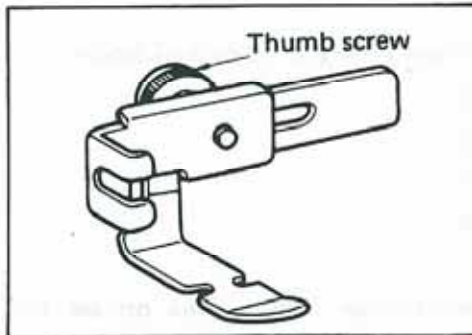

Zipper foot is used to sew various types of zippers and can easily be positioned to right or left side of needle. When zipper is being sewn at right side of needle, position zipper foot by loosening thumb screw and sliding zipper foot to the left.

When zipper is being sewn at left side of needle, position zipper foot by loosening thumb screw and slide zipper foot to the right.

STITCH LENGTH	: 2 ~ 3
STITCH WIDTH	: 0
NEEDLE POSITION	: M
PRESSER FOOT	: Zipper Foot
NEEDLE	: Single
PRESSURE ADJUSTER	: According to the material

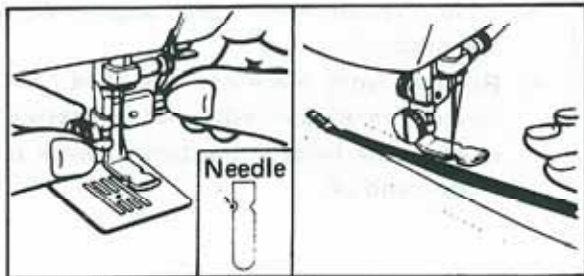

1. Lower needle into side notch located on presser foot (right or left).
2. Tighten thumb screw to lock presser foot into position.
3. Fold edge of material 3/4 inch (2 cm) and place zipper under folded portion.
4. By guiding zipper foot along the zipper teeth, you will stitch close to edge of zipper in correct position.
5. To sew opposite side of zipper, loosen thumb screw and position zipper foot (right or left).

Gathering

STITCH LENGTH	: 4
STITCH WIDTH	: 0
NEEDLE POSITION	: M
PRESSER FOOT	: Straight
NEEDLE	: Single
PRESSURE ADJUSTER	: According to the material

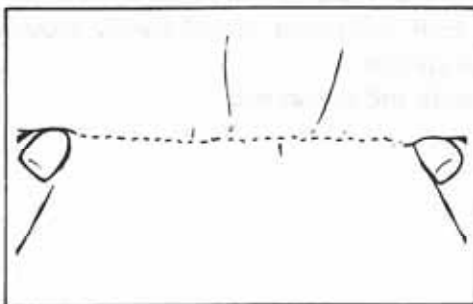

1. Loosen upper thread tension (set dial at about '2') so that lower thread lies on the underside of material.
2. Sew a single row or multiple rows of straight stitching.
3. Pull lower thread(s) to gather up material.

Darning

STITCH LENGTH	:	Set any position
STITCH WIDTH	:	0
NEEDLE POSITION	:	M
PRESSER FOOT	:	Straight
NEEDLE	:	Single
PRESSURE ADJUSTER	:	Up
OTHERS	:	Darning Plate

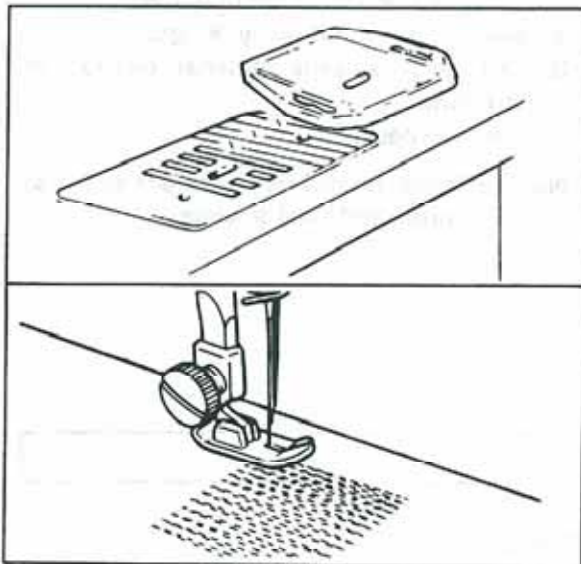

1. Set darning plate on the needle plate as illustrated.
2. Place portion to be darned under the presser foot together with underlay.
3. Lower presser foot.
4. Sew alternately drawing the work gently away from you and pulling it toward you.
5. Repeat this motion until the portion to be darned is filled with parallel lines of stitching.

Attaching Lace

STITCH LENGTH	:	2 ~ 4
STITCH WIDTH	:	0
NEEDLE POSITION	:	M
PRESSER FOOT	:	Zigzag
NEEDLE	:	Single
PRESSURE ADJUSTER	:	Accroding to the material

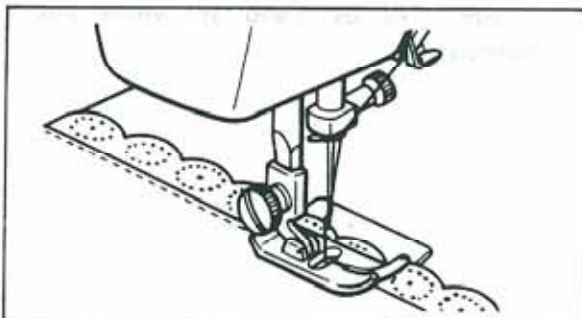

1. Place lace under material letting it overlap edge 1/4 inch (5 mm).
2. Place under presser foot and sew.

NOTE: If satin stitch or decorative stitch is used to sew lace, it will add an decorative touch.

Appliqueing

STITCH LENGTH	:	F ~ 2
STITCH WIDTH	:	1 ~ 3
NEEDLE POSITION	:	M
PRESSER FOOT	:	Zigzag
NEEDLE	:	Single
PRESSURE ADJUSTER	:	According to the material

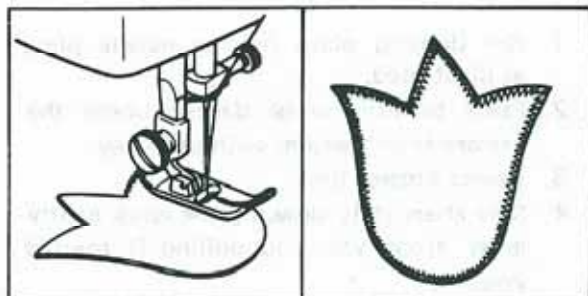

1. Baste cut design to the material.
2. Sew carefully following design.
3. Cut away surplus material outside of stitching.
4. Remove basting.

NOTE: Make reinforcement *straight* stitch at initial and final sewings.

Cording

STITCH LENGTH	:	F ~ 2
STITCH WIDTH	:	In accordance with thickness of cord being used, set stitch width.
NEEDLE POSITION	:	M
PRESSER FOOT	:	Zigzag
NEEDLE	:	Single
PRESSURE ADJUSTER	:	According to the material

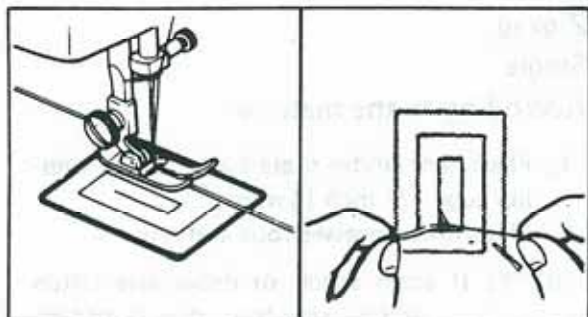

1. Set stitch width knob.
2. Place cord on fabric to be sewn.
3. Lower presser foot, making sure cord is centered and sew using zigzag stitch. Guide cord by hand to where you desire it.

Blind Stitch

SITTCH LENGTH	:	2 ~ 3
STITCH WIDTH	:	3 ~ 5
NEEDLE POSITION	:	M
PRESSER FOOT	:	Zigzag
NEEDLE	:	Single
PRESSURE ADJUSTER	:	According to the material

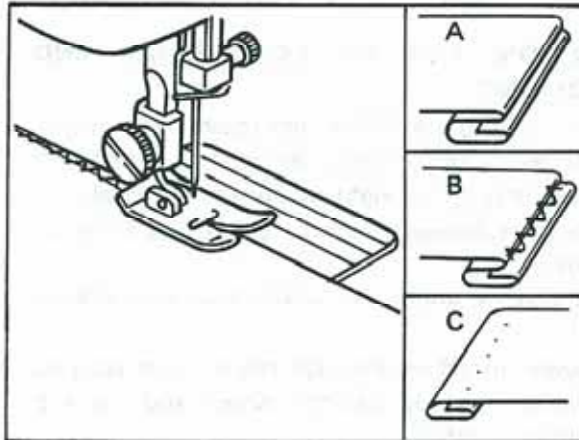

1. Fold the material into the size of the hem desired and fold back as shown in Fig. A with (5 mm 1/5 inch) overlapping on the bottom fold of the edge.
2. Start to sew on the fold, making the needle slightly to touch the folded top. (Fig. B)
3. After finish, unfold the material and you will have a blind stitch hem. (Fig. C)

NOTE: Use the same color thread as the material.

Overlock

STITCH LENGTH	:	3 ~ 4
STITCH WIDTH	:	5
NEEDLE POSITION	:	M
PRESSER FOOT	:	Zigzag
NEEDLE	:	Single
PRESSURE ADJUSTER	:	According to the material

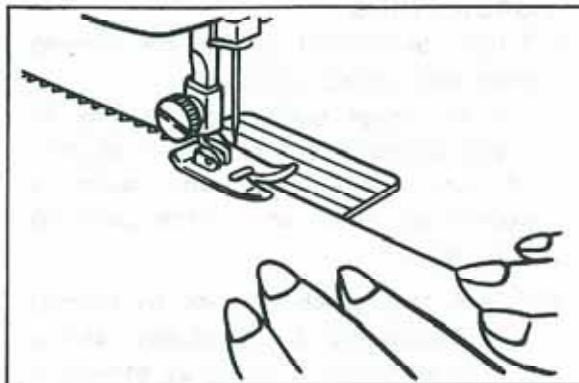

The overlock stitch is used to avoid fraying the edge of material.

Place edge of the material under presser foot so that the needle sews material with its left side of zigzag stitch and just misses the edge of material with its right side of zigzag.

Monogramming and Embroidering, Using Embroidery Hoop

STITCH LENGTH	:	Set at any position
STITCH WIDTH	:	0 ~ 5
NEEDLE POSITION	:	M
PRESSER FOOT	:	Removed
NEEDLE	:	Single
PRESSURE ADJUSTER	:	Up
OTHERS	:	Darning Plate

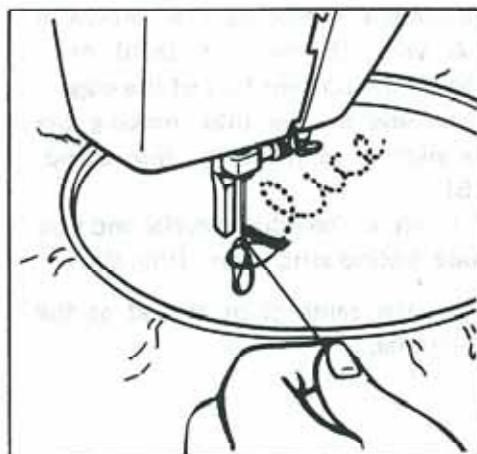

PREPARATION FOR MONOGRAMMING AND EMBROIDERING

1. Set your sewing machine as per above instructions.
2. Draw lettering (for monogramming) or design (for embroidering) on the right side of the material.
3. Stretch work between embroidery hoops as firmly as possible.
4. Place the work under the needle and lower presser bar.
5. Pull lower thread up through the work at starting position by turning balance wheel and make a few holding stitches.
6. Hold the hoop with thumb and forefingers of both hands while pressing the material with middle and third fingers and supporting the outside of hoop with smaller finger.



MONOGRAMMING

1. Sew, moving hoop slowly along the lettering at an even rate of speed.
2. Secure with a few straight stitches.

(NOTE: These instructions also apply to embroidering)

EMBROIDERING

1. Stitch outline of design by moving embroidery hoop accordingly.
2. Fill in design stitch from outline of design to inside and from inside to edge of outline alternately until design is completely filled in. Keep stitching close together.

NOTE: A long stitch is made by moving embroidery hoop rapidly and a short stitch is made by moving it slowly.

Cleaning

The sliding parts of the shuttle race should be cleaned regularly so that lint does not accumulate.

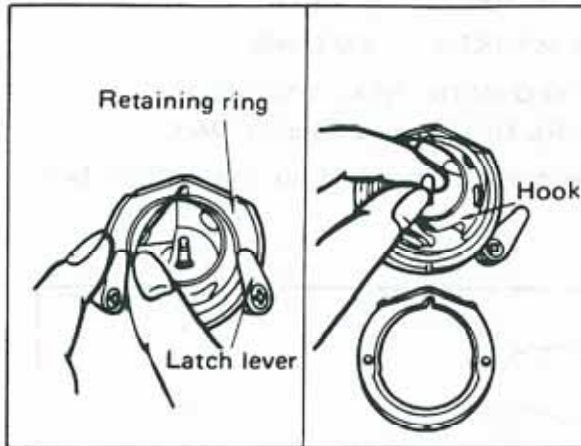

HOW TO REMOVE THE SHUTTLE HOOK

1. Raise needle to its highest position.
2. Open shuttle cover.
3. Take out bobbin case.
4. Push latch levers outside and remove retaining ring.
5. Remove hook by grasping center post of hook.

NOTE: When needle is lowered, shuttle hook cannot be removed.

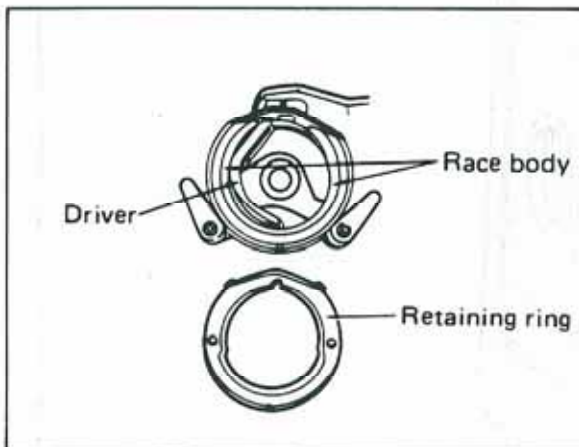

CLEANING SHUTTLE RACE

1. Remove accumulated lint and thread from the retaining ring, hook, driver and race body with brush.
2. A cloth dampened with machine oil should be used to wipe shuttle race clean.
3. Clean shuttle hook in same manner as above.
4. Reassemble.

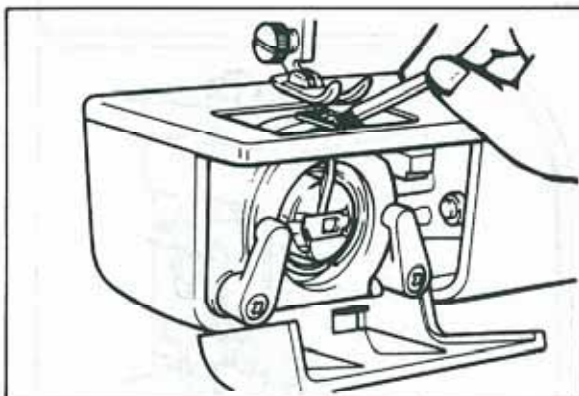

CLEANING FEED DOG

1. Take out needle plate.
2. Clean upper part of feed dog and shuttle race body with brush.

How to Oil Sewing Machine

For smooth and silent operation, the moving parts of the machine should be oiled periodically. (See diagram below.)

OIL 1 to 2 DROPS TO THE POINTS MARKED 

OIL 3 to 4 DROPS TO THE POINTS MARKED 

OIL ONCE A WEEK IF MACHINE IS USED MORE THAN ONE HOUR PER DAY. IF MACHINE IS USED MORE OFTEN, OIL EVERY DAY.

After the machine has been oiled, remove thread and with presser foot up, run machine fast. Then wipe up any excess oil.

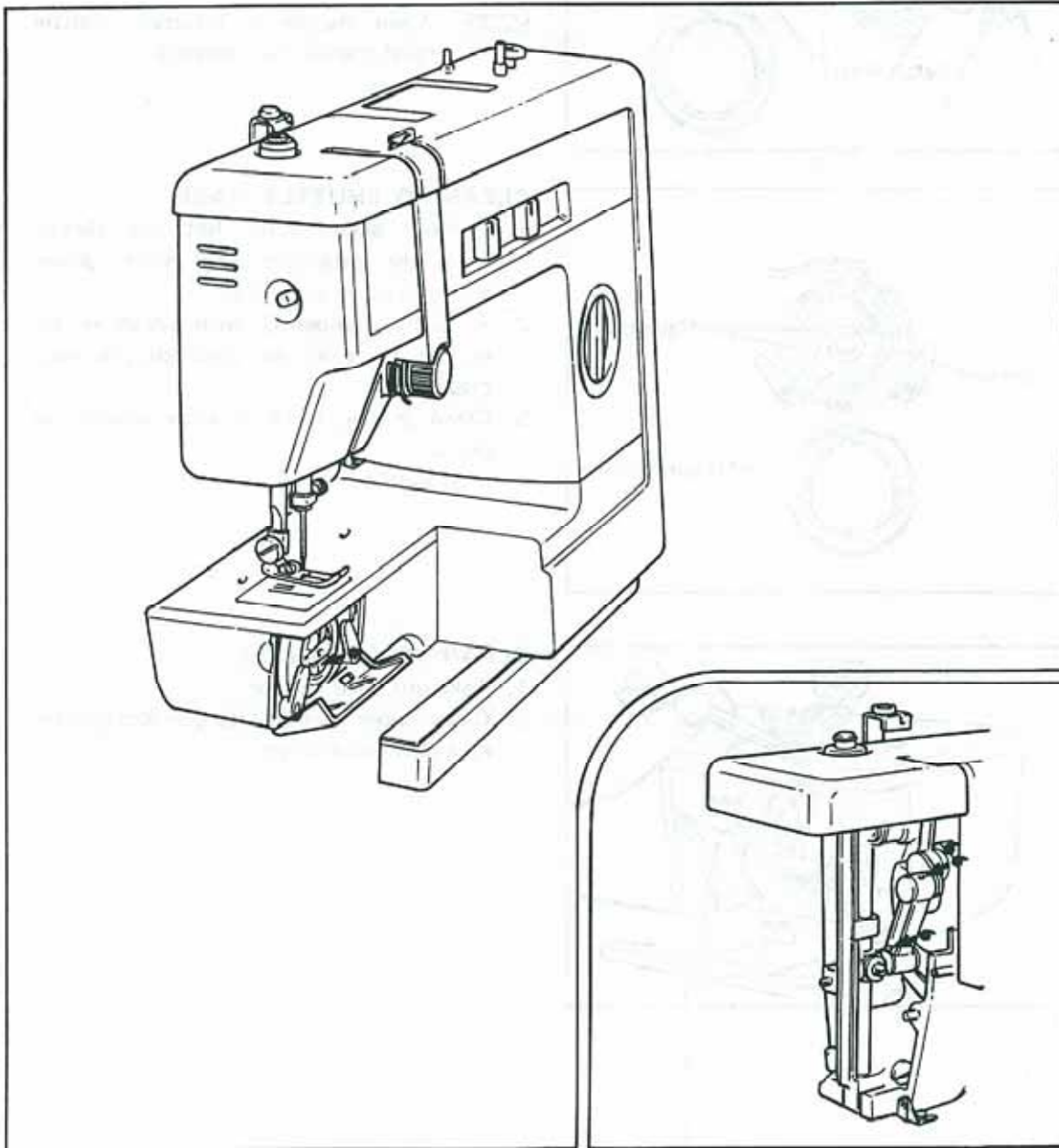

Occasionally, remove the top cover by loosening two screws on it and apply machine oil to oiling points as illustrated.

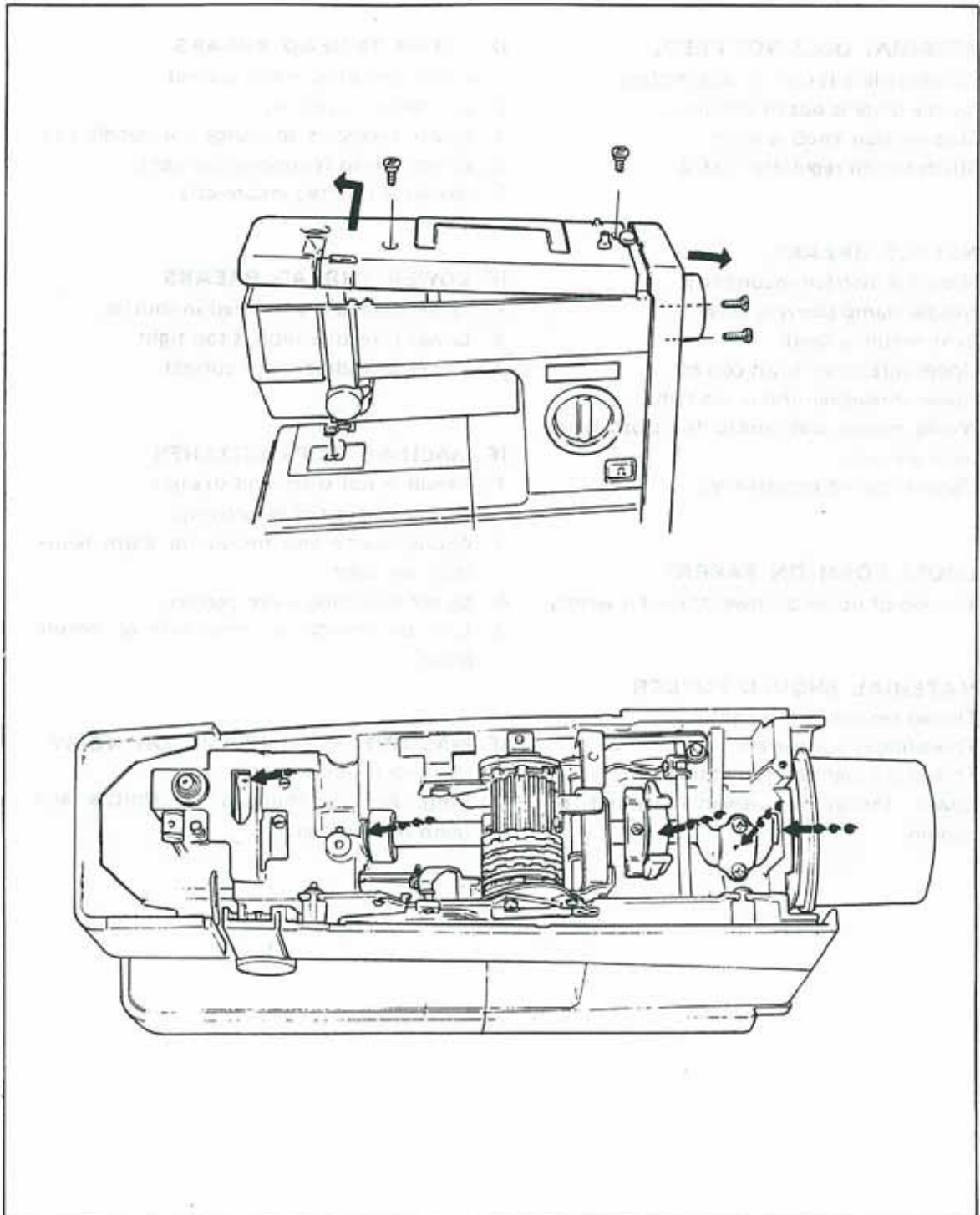

NOTE: If machine has not been used for a long period of time, oil tends to coagulate and operation of machine will not be smooth. Apply a few drops of oil to oiling points, and with presser foot up run machine for a few minutes. Then wipe up any excess oil.

Check List for Better Sewing

Check this list if you are having the following problems:

IF MATERIAL DOES NOT FEED.

1. Darning plate is on the needle plate.
2. Needle plate is out of position.
3. Stop motion knob is loose.
4. Stitch length regulator is at 0.

IF NEEDLE BREAKS

1. Needle is inserted incorrectly.
2. Needle clamp screw is loose.
3. Bent needle is used.
4. Upper threading is not correct.
5. Upper thread tension is too tight.
6. Wrong needle and thread for cloth being sewn are used.
7. Material pulled excessively.

IF LOOPS FORM ON FABRIC

1. Tension of upper or lower thread is wrong.

IF MATERIAL SHOULD PUCKER

1. Thread tension is too tight.
2. Threading is not correct.
3. Thread is caught by something.
4. Lower thread is unevenly wound on bobbin.

IF UPPER THREAD BREAKS

1. Upper threading is not correct.
2. Needle eye is not sharp.
3. Upper thread is too large for needle eye.
4. Upper thread tension is too tight.
5. Needle is inserted incorrectly.

IF LOWER THREAD BREAKS

1. Lower thread is entangled in shuttle.
2. Lower thread tension is too tight.
3. Lower threading is not correct.

IF MACHINE SKIPS STITCHES

1. Needle is not sharp and straight.
2. Needle is inserted incorrectly.
3. Wrong needle and thread for cloth being sewn are used.
4. Upper threading is not correct.
5. Lint is clinging to under-side of needle plate.

IF MACHINE RUNS HEAVY OR NOISY

1. Machine is out of oil.
2. Lints has accumulated on shuttle and teeth of feed dog.

Repacking the Machine

Keep the carton and packing material for future use in the event it becomes necessary to reship the sewing machine.

(Improper packing or improper packing material could result in damage during shipping.)
Instructions for repacking the machine are illustrated below.

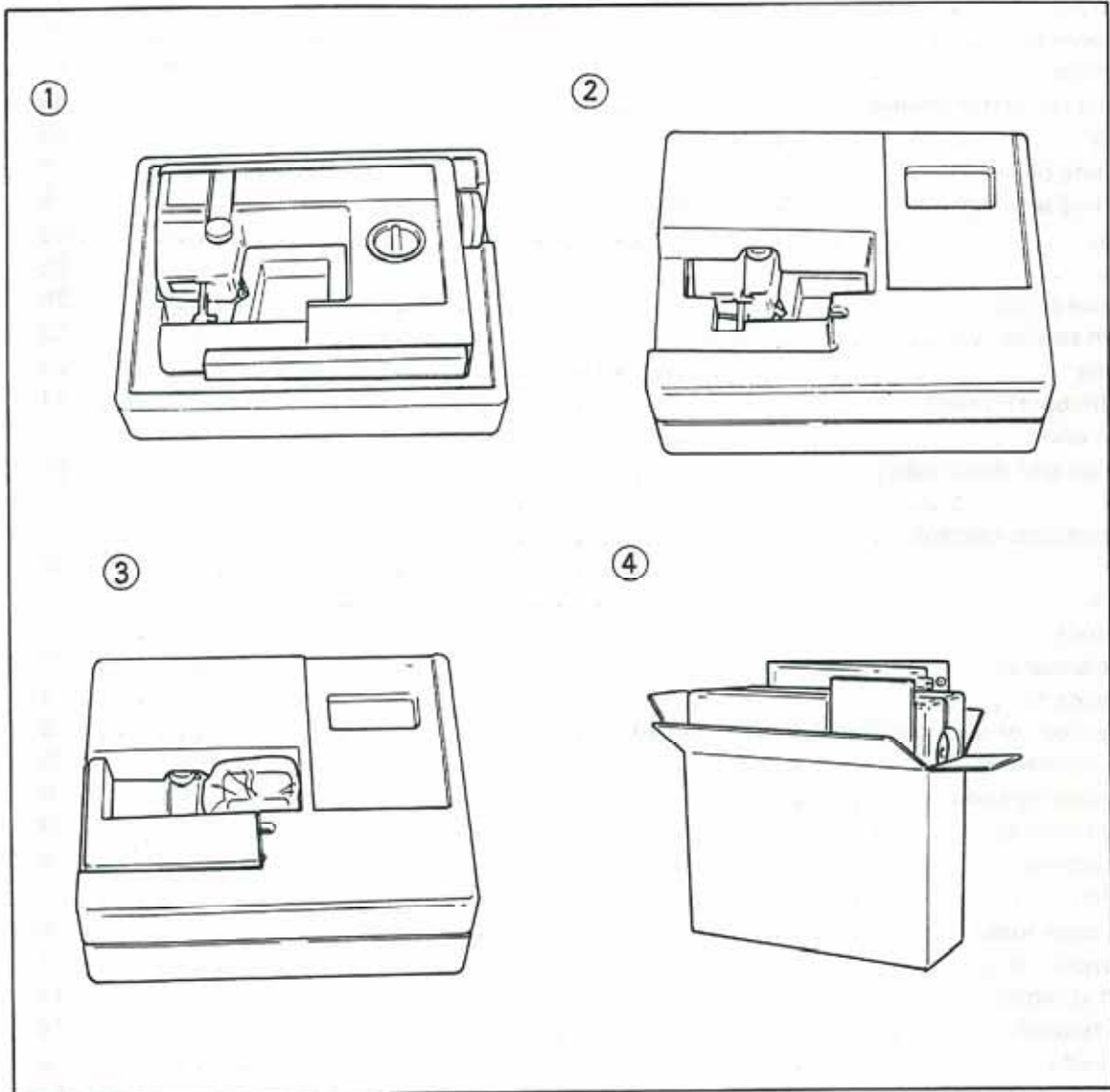

Index

Accessories	4
Appliqueing	26
Attaching lace	25
Blind stitch	27
Bobbin case	12
Button sewing	23
Buttonholes	21
Check list for better sewing	32
Cleaning	29
Connecting plugs	5
Controlling sewing speed	5
Cording	26
Darning	25
Decorative stitch	20
Free-arm sewing	13
Gathering	24
Lower (bobbin) thread	11
Machine cover	3
Monogram and Embroidery	28
Needle	8
Needle position selector	7
Oiling	30
Overlock	27
Presser foot	7
Pressure adjuster	16
Principal parts	2
Relative chart of sewing material, needle, thread	9
Repacking the machine	33
Reverse sewing knob	6
Reverse stitching	18
Satin stitching	19
Sew-light	9
Stitch length knob	6
Stitch width knob	6
Straight stitching	17
Thread tension	14
Twin needle	8
Upper (needle) thread	10
Various control	6
Zigzag stitching	19
Zipper insertion	24

MEMO

MEMO



MODEL VX810/VX807/VX800
ENGLISH

194810-011

Free Manuals Download Website

<http://myh66.com>

<http://usermanuals.us>

<http://www.somanuals.com>

<http://www.4manuals.cc>

<http://www.manual-lib.com>

<http://www.404manual.com>

<http://www.luxmanual.com>

<http://aubethermostatmanual.com>

Golf course search by state

<http://golfingnear.com>

Email search by domain

<http://emailbydomain.com>

Auto manuals search

<http://auto.somanuals.com>

TV manuals search

<http://tv.somanuals.com>