

# Cisco TelePresence VX Tactical

USER GUIDE FOR VX TACTICAL

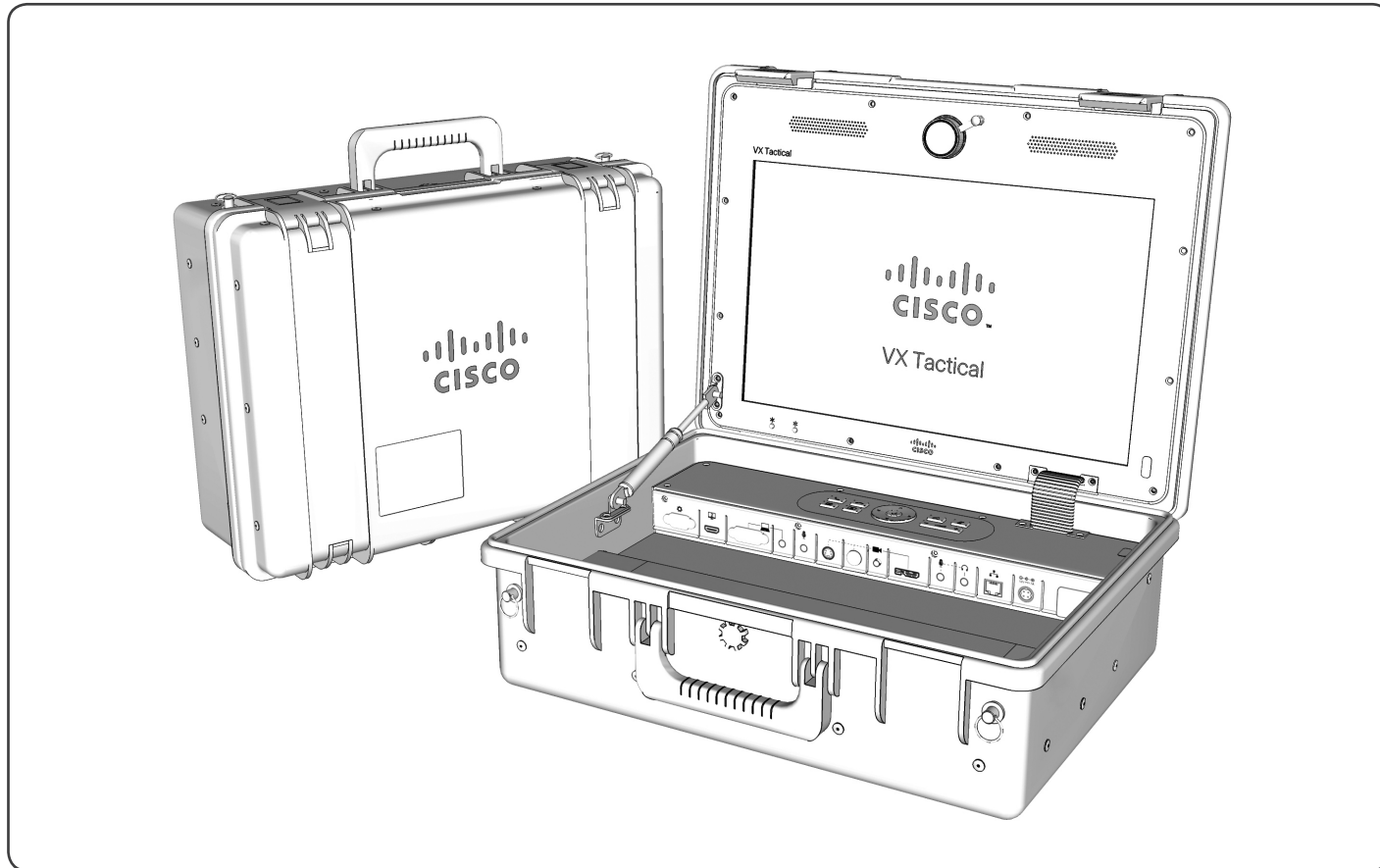

# Table of Contents



## What's in this guide?

Important Safety Instructions .....	3	Call Control Pad and Remote Control .....	12
Operator Safety Summary .....	4	Call Control Pad .....	12
Equipment Markings .....	4	Remote Control .....	12
Safety Precautions.....	5	Call Operation using the Call Control Pad.....	13
Warning.....	5	Answer an incoming call.....	13
Environmental Issues.....	5	Disconnect or reject a call.....	13
Waste Handling .....	5	Place a call .....	13
Add a call .....	5	Add a call .....	13
Introduction.....	6	Call Operation using the Remote Control.....	14
System Overview.....	7	Answer an incoming call.....	14
Display, Integrated Camera, Speakers, Microphone, and IR Sensors .....	8	Disconnect or reject a call.....	14
Place a call from Directory.....	8	Place a call from Directory.....	14
Place an ad hoc call .....	8	Place an ad hoc call .....	14
Add a call .....	8	Add a call .....	14
Share Content .....	8	Share Content .....	14
Installing the Optional I/O Cover .....	9	Cleaning the System.....	15
I/O Interface Panel .....	10		
Powering the System.....	11		

**NOTE:** The VX Tactical's Cisco TelePresence SX20 Codec must first be provisioned and configured on an appropriate network to place telepresence calls.

Please refer to the following URL for information about provisioning, configuration, and operation of the SX20 Codec:

<http://www.cisco.com/go/telepresence/docs>

# Important Safety Instructions



This warning symbol means danger. You are in a situation that could cause bodily injury. Before you work on any equipment, be aware of the hazards involved with electrical circuitry and be familiar with standard practices for preventing accidents.

NOTE: **SAVE THESE INSTRUCTIONS**

NOTE: This documentation is to be used in conjunction with the specific product installation guide that is shipped with the product. Please refer to the Installation Guide, Configuration Guide or other enclosed additional documentation for details.

Read the installation instructions/user manual before connecting the system to the power source.

Ultimate disposal of this product should be handled according to all national laws and regulations.

## Power Cable and AC Adapter

When installing the product, please use the provided or designated cables/power cables/AC adaptors. Using any other cables/adaptors could cause a malfunction or a fire. Electrical Appliance and Material Safety Law prohibits the use of UL-certified cables (that have the "UL" shown on the code) for any other electrical devices other than products designated by CISCO. The use of cables that are certified by Electrical Appliance and Material Safety Law (that have "PSE" shown on the code) is not limited to CISCO-designated products.

# Operator Safety Summary



For your protection, please read these safety instructions completely before operating the equipment and keep this manual for future reference. The information in this summary is intended as general guidance for those who operate the equipment as well as repair (servicing) personnel. Carefully observe all warnings, precautions and instructions on the system, or the ones described in the operating instructions and adhere to them.

## Equipment Markings

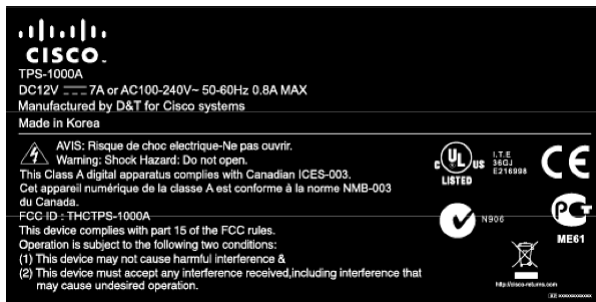

- Cleaning - Unplug the system from the power source before cleaning or polishing. Please adhere to the general cleaning guidelines found in this document's section: "Cleaning the System."
- Grounding- This equipment must be grounded. Never defeat the ground conductor or operate the equipment in the absence of a suitably installed ground conductor. Contact the appropriate electrical inspection authority or an electrician if you are uncertain that suitable grounding is available.
- Power-Cord Protection - Route the power cord so as to avoid it being walked on or pinched by items placed upon or against it, paying particular attention to the plugs, receptacles, and the point where the cord exits from the system.
- Attachments - Only use attachments as recommended by the manufacturer and in accordance to the system guidelines in this document.
- Lightning - Unplug this system during lightning storms or when unused for long periods of time.
- Servicing - Do not attempt to service the system yourself as opening or removing covers may expose you to dangerous voltages or other hazards, and will void the warranty. Refer all servicing to qualified service personnel.
- Storage - If you need to store the system, ensure that it is stored in a controlled environment to avoid damage. Refer to the codec documentation for further guidelines.
- Mobility & Portability – Before moving the system it is recommended that the power cord and other connected equipment are unplugged and disconnected. Securely close the case with its latches and use the carry handle to transport the system to another location.
- Damaged Equipment - Unplug the system from the outlet and refer servicing to qualified personnel under the following conditions:
  - When the power cord or plug is damaged or frayed
  - If the system has been subjected to excessive shock by being dropped, or the unit has been damaged
  - If the system fails to operate in accordance with the operating instructions.

# Safety Precautions



## Warning

While this system is designed for portability and durability, users should use precaution during use and transportation of the system to ensure their safety and prevent damage to the unit.

### For Customers In North America

This equipment complies to the limits for a Class A digital device, pursuant to Part 15 of the FCC Rules.

These limits are designed to provide reasonable protection against harmful interference when the equipment is operated in a commercial environment. This equipment generates, uses, and can radiate radio frequency energy, which may cause harmful interference to radio communications.

You are cautioned that any changes or modifications not expressly approved in this manual could void your authority to operate this equipment

## Environmental Issues

Thank you for buying a product, which contributes to a reduction in pollution, and thereby helps save the environment. Our products reduce the need for travel and transport and thereby reduce pollution. Our products have either none or few consumable parts (chemicals, toner, gas, paper). Our products are low energy consuming products.

### Battery handling

Batteries for the Remote Control are Long Life Alkaline batteries; please follow guidelines on the packing material for handling and disposal of the batteries.

### Production of Products

Our factories employ efficient environmental methods for reducing waste and pollution and ensuring the products are recyclable.

## Waste Handling

### EU Battery and WEEE Directives

Your Cisco product may contain a user replaceable battery or a permanently affixed battery as indicated in the user manual. For product safety and data integrity reasons a permanently affixed battery should only be removed or replaced professionally by a repair technician or waste management professional. Please contact Cisco or an authorized service agent if the product fails to perform due to malfunction of the permanently affixed battery.



This symbol on a Cisco product, battery or packaging means that the product and/or battery should not be disposed of with your household waste.

It is your responsibility to dispose of your waste equipment and batteries separately from your household waste and in accordance with local laws and regulations. The correct disposal of your old equipment and batteries will help prevent potential negative consequences for the environment and human health.

Please use the nearest waste collection facility as directed by your municipality or your retailer.

# Introduction



The VX Tactical puts the power of TelePresence into a compact and mobile solution. Designed for portability and ease of use the VX Tactical is a high-definition video collaboration system with functionality that facilitates remote communication and collaboration.

This portable endpoint is part of the Cisco TelePresence portfolio, which offers video recording, firewall traversal, and video management capabilities. The VX Tactical can help overcome the barrier of distance by enabling effective collaboration in any setting.

## Key Features of VX Tactical:

- Water-, sand-, impact-, chemical- and corrosion-resistant case providing portability, durability and functionality.
- Cisco TelePresence SX20 codec featuring high-definition (HD) video and content sharing with full-duplex audio.
- Embedded 1080p HD camera and integrated speakers and microphone
- Sunlight readable, optically bonded, 17.5-inch 720p60 HD display that is 3x stronger than standard screens.
- Tactile control panel offering simplified system control and a tethered infrared remote control for full system operation
- AC and DC power options for system operation
- Security hasps (2x) for securing the unit.

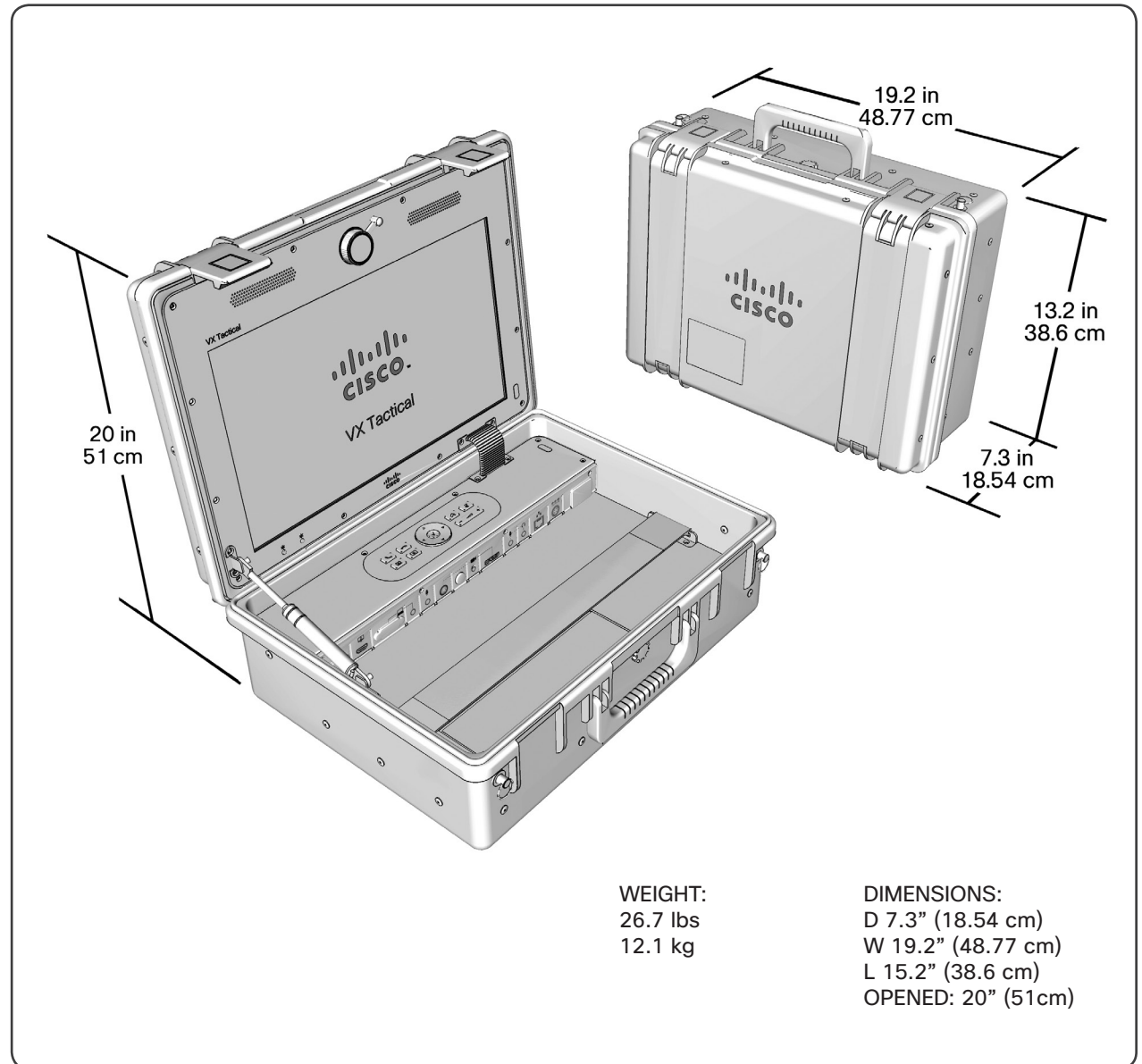

# System Overview

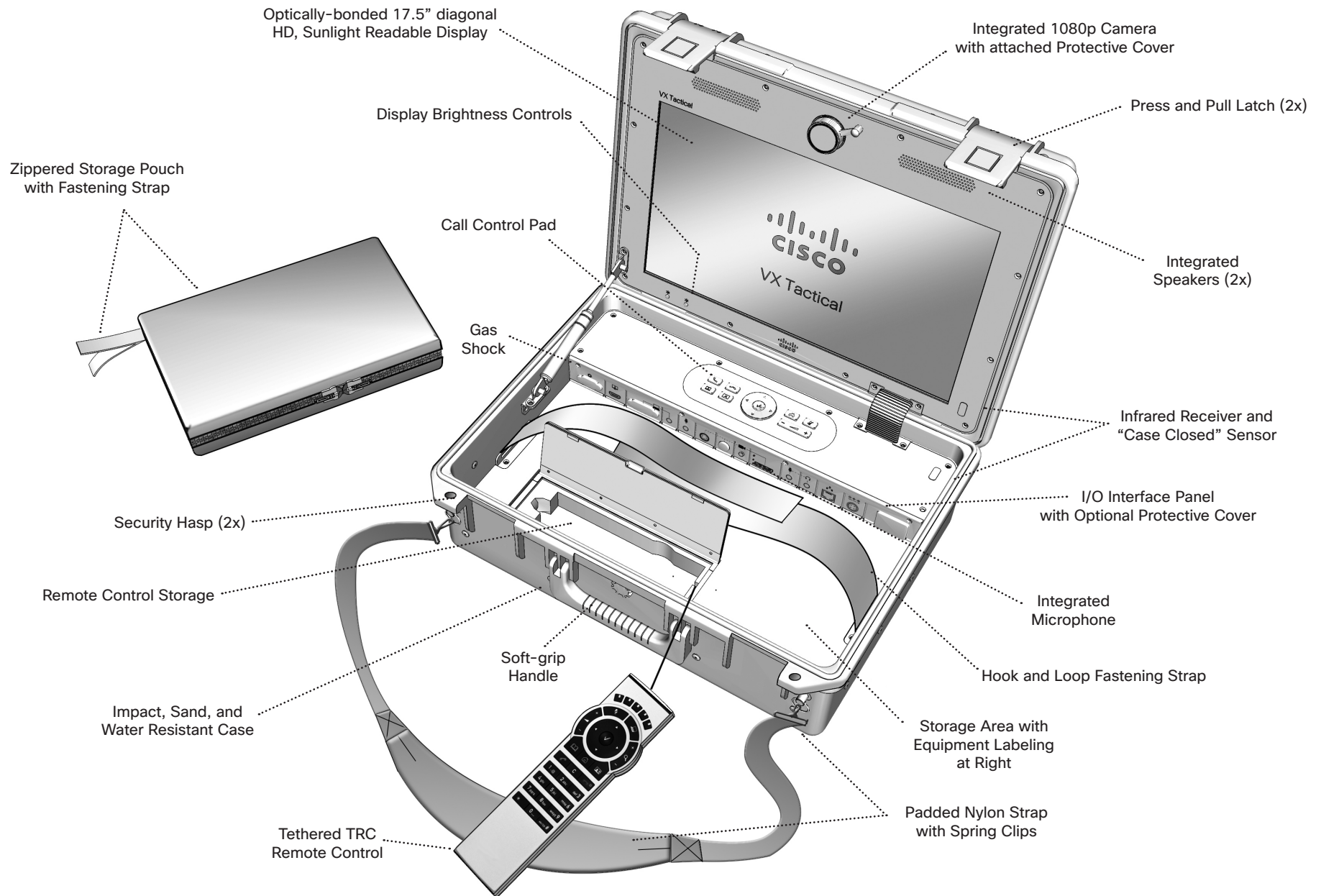

# Display, Integrated Camera, Speakers, Microphone, and IR Sensors



## Display

When powering on the system, the HD 17.5" (44.45 cm) sunlight-readable display will show a static image of the Cisco VX Tactical logo during codec boot up. This will persist on-screen until the system's codec has booted up fully.

The display is optically bonded making it much stronger than standard screens and provides a highly impact resistant screen able to endure relatively harsh environments.

## Brightness Control

Use the Brightness Control buttons to adjust the display's brightness to suit the environment.

## Embedded Camera

The 1080p 1/3" CMOS camera can be manually focused by gently turning the camera to the left or right.

## Integrated Speakers

System audio is heard through the waterproof stereo speakers. Connecting a headset into the HEADSET jack will switch system audio from the speakers to the headset.

## Embedded System Microphone

The embedded microphone is used to capture audio from local users. Connecting to MIC2 will supplement the call utilizing both the system mic and the secondary mic. Connecting a mic into headset MIC1 will switch the system mic off and enable the audio to be heard through MIC1 (and MIC2 if connected).

## IR Sensors

The IR sensor at the corner of the display is used to receive commands from the tethered remote control.

The IR sensor found atop the interface panel triggers the display to enter "standby mode" when the case is closed. Both IR sensors must be clear of obstruction in order for the display to enter standby.

NOTE: Closing the case will disconnect all calls.

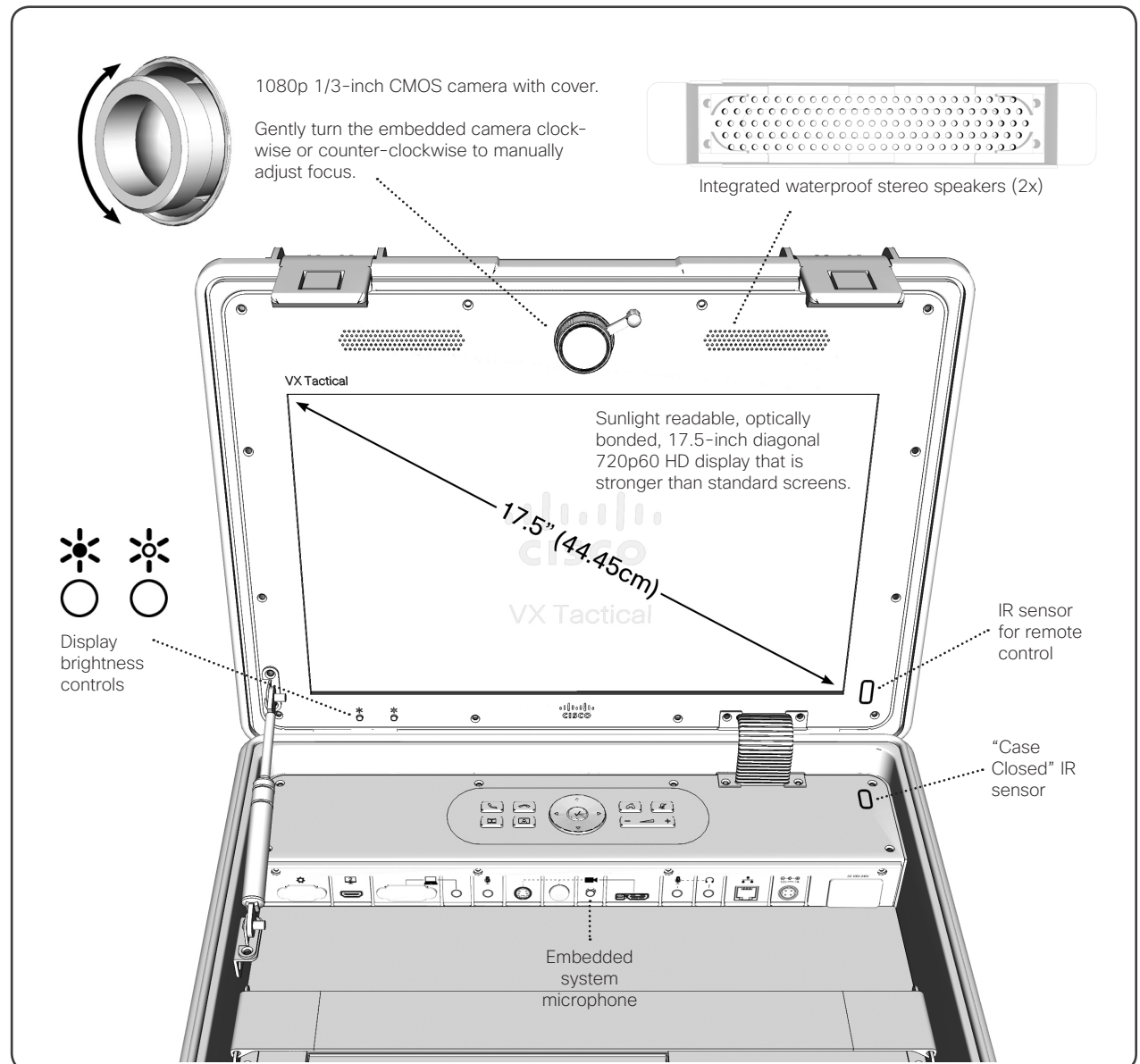



# Installing the Optional I/O Cover

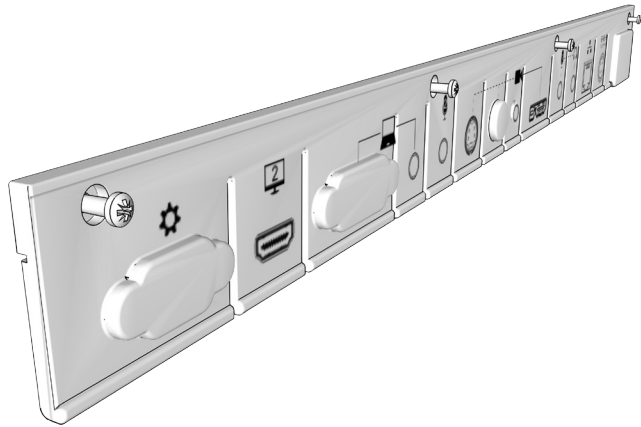

An optional I/O Cover is included and may be installed to provide additional protection of the connectors found on the Interface Panel.

1. Align the four (4) screw holes along the top of the Interface Panel with the I/O Cover and its corresponding holes.
2. Use a small Phillips screwdriver to secure the provided screws (4) to the holes on the Interface Panel.

To remove the I/O Cover, use a small Phillips screwdriver to remove the four (4) screws and pull the cover away from the system.

Store in a safe place if ever the I/O Cover should be needed again.

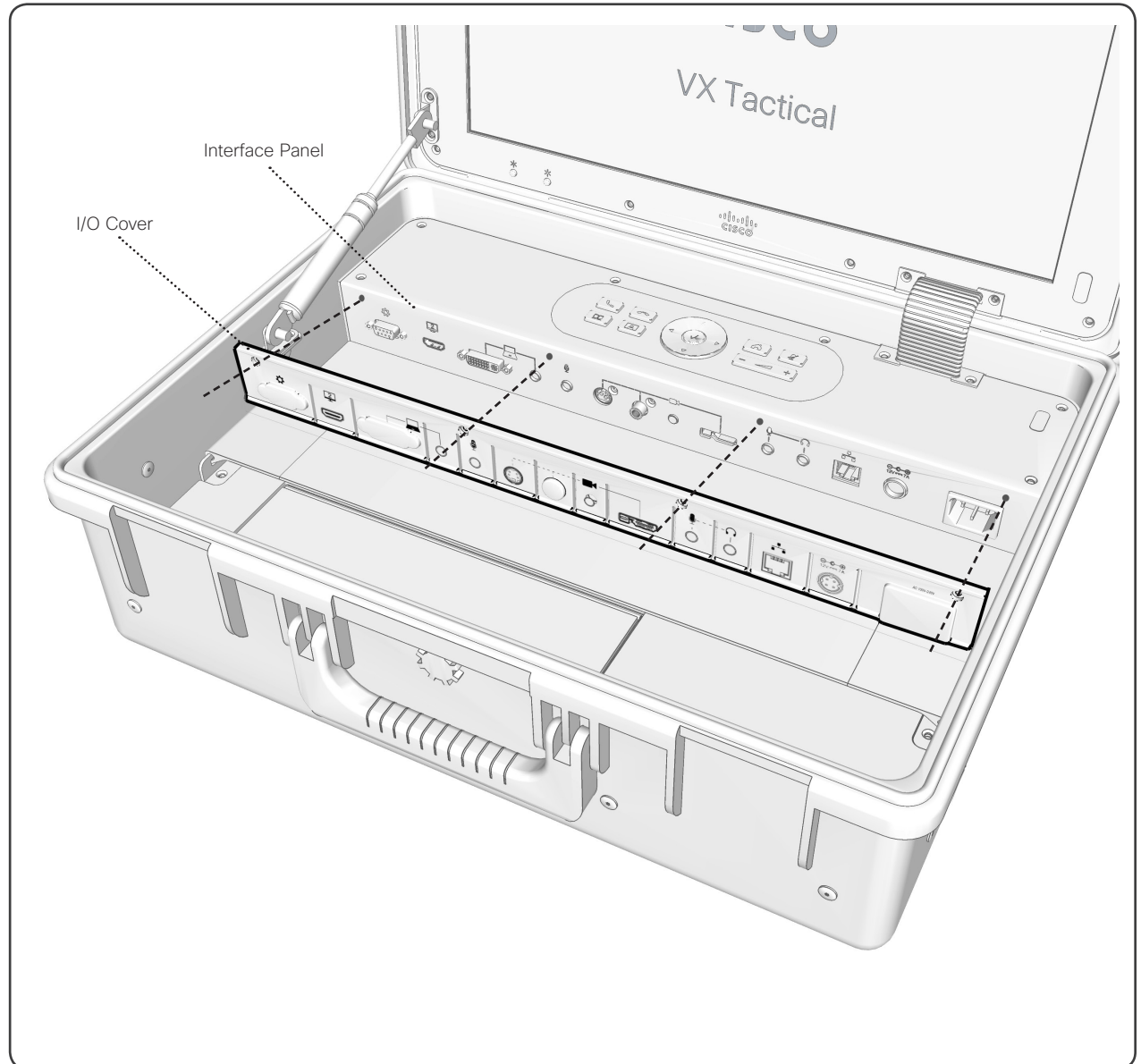

# I/O Interface Panel

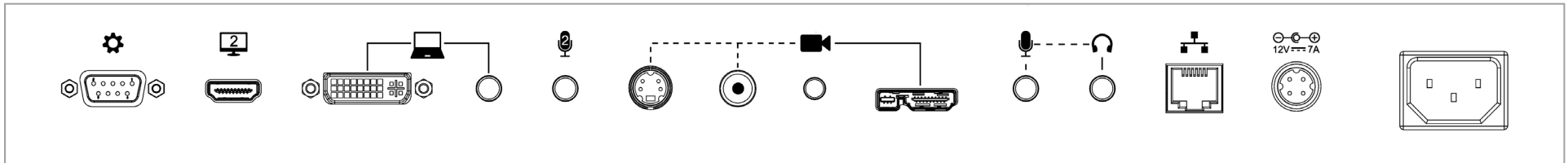

## Serial Port

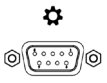
 Administrative use only. Used for firmware upgrades and diagnostics. Only connect when instructed by certified Cisco technician. NOTE: This not a connection to the Codec.

## HDMI Display Out

 Connect a second display to HDMI OUT (e.g., for viewing on a larger screen).

Display output (HDMI 2) is configurable via system menus: **SETTINGS > ADMINISTRATOR SETTINGS > ADVANCED CONFIGURATION > VIDEO > OUTPUT > HDMI 2** using the Navigation Buttons.

## PC (DVI-I In / Audio In)

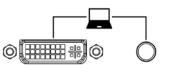
 Use the DVI-I connection to share content from a computer or other device to the VX Tactical screen and/or with remote participants.

PC Audio can be added by plugging in a 3.5mm audio plug.

## Microphone 2 In

 Connect a secondary room microphone to enhance the telepresence call.

NOTE: MIC2 audio can still be heard when a headset microphone is connected to MIC.

If using the optional Cisco Performance Mic 20 microphone, the Mute Button will mute ALL system microphones, as will the Mute Button on the TRC Remote.

## Camera (Video) In

 When the system detects

video from an alternate Camera video source, it will override the integrated VX Tactical camera. If there is no alternate source detected the system camera will be active.

The order of priority for alternate sources begin with the HDMI connection. Camera control is available if using a Cisco Precision HD Camera.

The second and third priorities go to the Composite input and to the S-Video input respectively.

## System Microphone

 This is an embedded microphone to pick up audio from local users.

## Headset and Microphone In

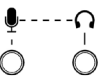
 Connect a headset with microphone to the 3.5mm input to provide audio privacy in a public setting or clarity in a noisy environment.

The audio will be diverted from the VX Tactical speakers and will be heard only through the connected headset.

When a headset microphone is connected to MIC input, the embedded mic will be turned off. Audio from MIC2, if connected, can still be heard when a headset microphone is connected.

NOTE: This microphone input is designed for a 3-Pin 3.5mm connection.

## Network In

 Use the Ethernet connection to provide network for the VX Tactical.

## DC Power In (Secondary)

 The 12V DC Power 4-Pin DIN connection provides alternate power to the VX Tactical when AC Power (Primary) is not available. A DC-DC Converter is provided to accommodate 12~32V DC.

## AC Power In (Primary)

 Provide power to the VX Tactical using 100~240V AC 50-60Hz.

# Powering the System



The VX Tactical provides two options for powering the system.

**NOTE:**

The system will not operate unless connected to an appropriate power source.

**AC Power In (Primary)**



Provide power to the VX Tactical using 100~240V AC 50-60Hz. Use a country specific plug/adaptor to supply power.

**DC Power In (Secondary)**



The 12V DC Power 4-Pin DIN connection provides alternate power to the VX Tactical when AC Power (Primary) is not available. A DC-DC Converter is provided to accommodate 12~32V DC.

**NOTE:**

AC Power takes priority when both AC and DC power are connected -- the DC inlet will switch off when AC power is present. DC power will switch on when AC power is absent.

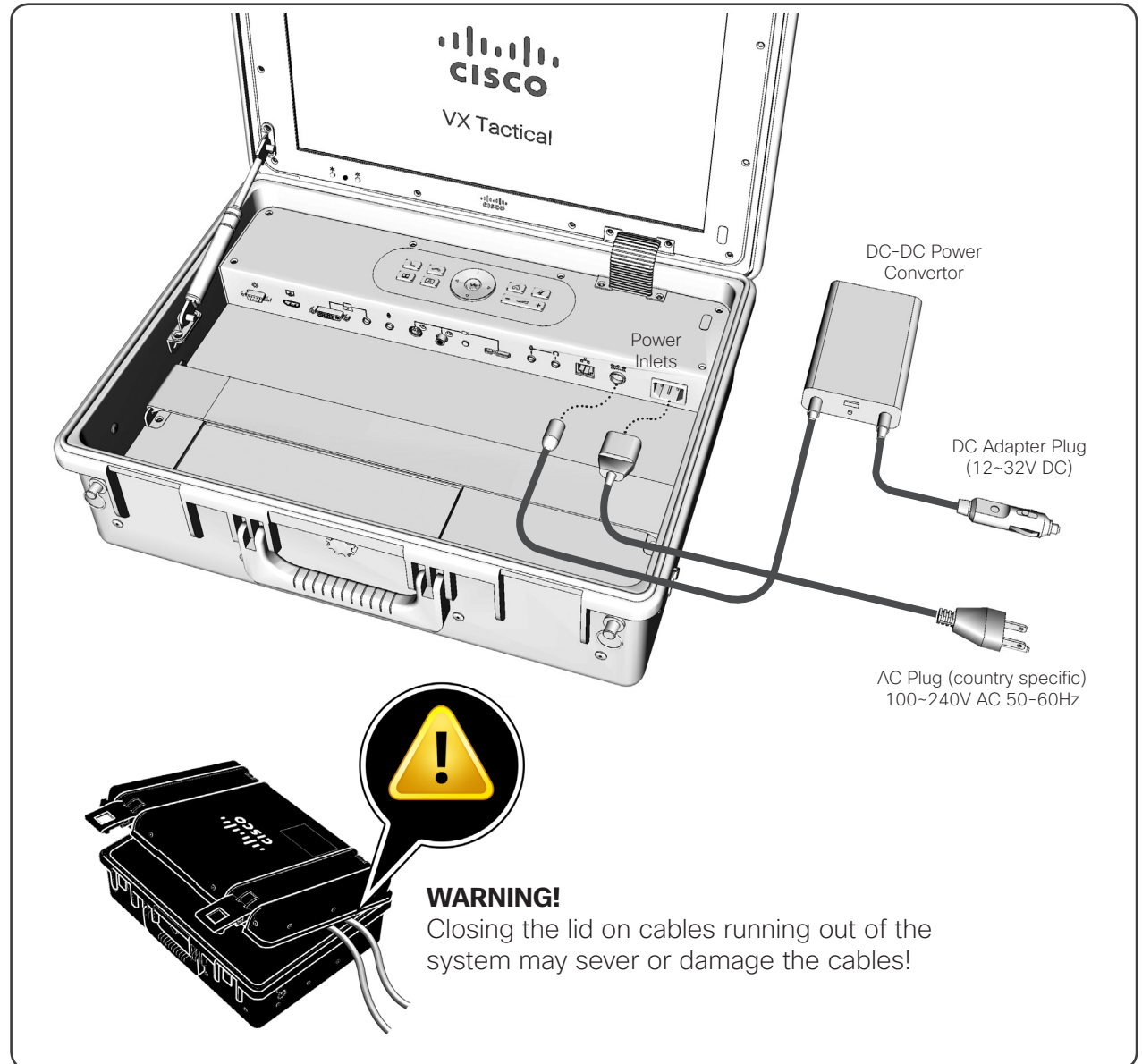

**WARNING!**





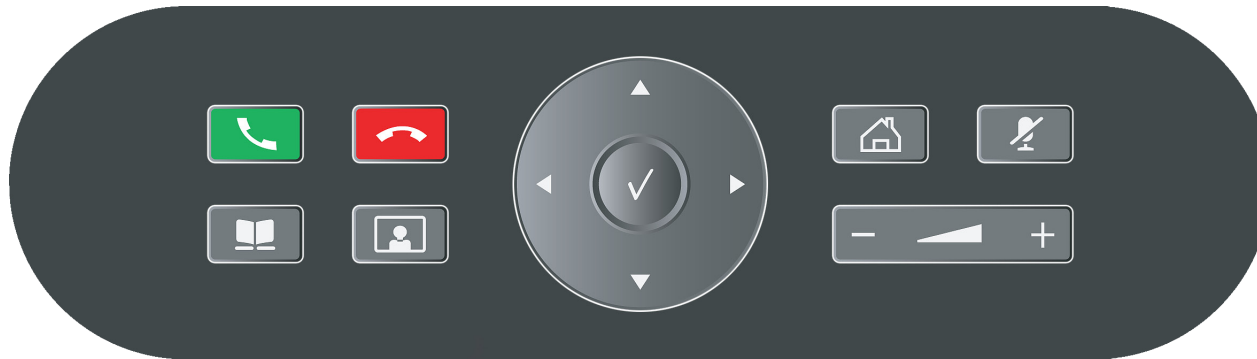

Closing the lid on cables running out of the system may sever or damage the cables!

# Call Control Pad and Remote Control



## Call Control Pad

The VX Tactical features a simplified Call Control interface for quick operation and ease of use.

-  The green CALL button initiates a call.
-  The red DISCONNECT button ends a call.
-  The DIRECTORY button pulls up the manually maintained local directory menu and any remote corporate directories.
-  Press SELFVIEW to see what others will see from your camera when in a call.
-  The HOME button shows and hides the main menu.
-  MIC MUTE switches all connected microphones on and off.



The VOLUME CONTROL adjusts audio levels from the system.



The NAVIGATION and OK buttons enable you to navigate the system's menu structure.

## Remote Control

The tethered remote control is housed under a magnetically latched cover. Lift the cover to access the remote control.

The retractable tether can extend up to 4' (121.92 cm).

To retract the remote, slightly pull the tether to release the catch and slowly return the remote control to its storage area.

NOTE: Detailed instructions for operating the Cisco Telepresence Remote Control can be found:

<http://www.cisco.com/go/telepresence/docs>

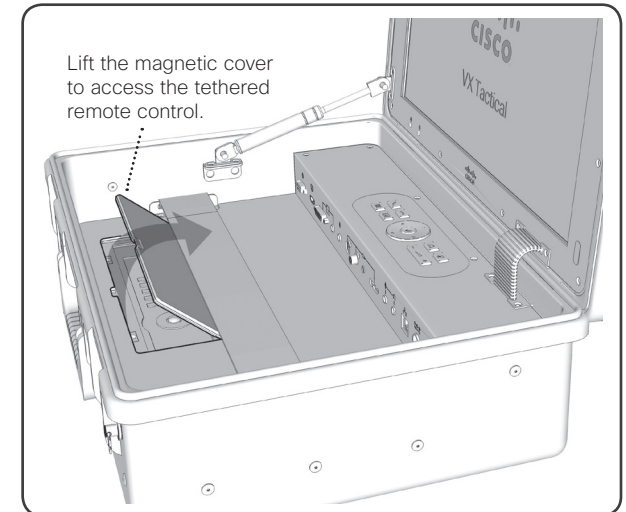

# Call Operation using the Call Control Pad





The VX Tactical's Call Control Pad has been designed to make receiving and placing a call quick and simple.

## Answer an incoming call

 Press the green Call Button to answer an incoming call. The call will then use the built-in speakers or connected headset.

## When in a call

 Press SELFVIEW to see what others will see from your camera when in a call.

 MIC MUTE switches all connected microphones on and off.

 The VOLUME CONTROL adjusts audio levels from the system.

## Disconnect or reject a call

 Press the red DISCONNECT button to terminate a call or reject an incoming call.

## Place a call

 Press the DIRECTORY button to display the directory listing. Please note that all locally created directory entries are stored under “My Contacts.” Additional directory entries will also be available if the system is configured on a network that can access them.

**NOTE:** Accessing corporate directories must be made available by a system administrator.

 Use the NAVIGATION button to find and select the directory entry to call.

 Press the OK button or the green CALL button to place the call.

**NOTE:** It is recommended that the “My Contacts” directory is pre-populated using the Remote Control. The simplified Call Control Pad limits the ability to create directory entries or enter numbers and characters to place a call “on-the-fly” without the aid of the tethered Remote Control.

**TIP:** When not in a call and all menus are closed, press the green CALL button to show the “Recent Calls” list.

## Add a call

The VX Tactical can support up to three (3) additional video participants to a telepresence call with the MultiSite option enabled.

## Add a call from Directory

 When in a call, you may choose to add another participant by pressing the DIRECTORY button, using the NAVIGATION button to select the desired participant, and pressing either OK button or the green CALL button to add a call.

You may connect up to three (3) video participants and one (1) audio participant to your telepresence session if MultiSite is enabled for your system.

## Add an incoming call

 While in a call and a call request is presented, press the green CALL button to answer that incoming call.

 Press the red DISCONNECT button to reject an incoming call.

# Call Operation using the Remote Control



While the operation principles are similar for the system's Call Control Pad and the Remote Control, the provided tethered Remote Control enables greater control of the VX Tactical's capabilities beyond what the Call Control Pad provides.

The following page shows an overview of the Remote Control's buttons and functions. Please refer to the Remote Control Guide for detailed instruction on remote control operation.

## Answer an incoming call



Press the green CALL button to answer an incoming call. The call will then use the built-in speakers or connected headset.

## When in a call



Press SELFVIEW to see what others will see from your camera when in a call. Press again to show Main Camera.



MIC MUTE switches all connected microphones on and off. Press again to toggle Mic On.



The VOLUME CONTROL adjusts audio levels from the system.

## Disconnect or reject a call



Press the red DISCONNECT button to terminate a call or reject an incoming call.

## Place a call from Directory



Press the DIRECTORY Button to display the directory listing. Please note that all locally created directory entries are stored under "My Contacts." Additional directory entries will also be available if the system is configured on a network that can access them.

NOTE: Accessing corporate directories must be made available by a system administrator.



Use the NAVIGATION button to find and select the directory entry to call.



Press the OK button or the green CALL button to place the call.

## Place an ad hoc call



Press the HOME button or the OK button to bring up the Onscreen Menu and select Call.



Use the ALPHANUMERIC KEYPAD to enter a number or URI and press the green CALL button to place the call.

## Add a call

When in a call, you may choose to add another participant by pressing the DIRECTORY button to select the desired participant, or enter a number or URI using the ALPHANUMERIC KEYPAD, and pressing either OK button or the green CALL button to add a call.

The VX Tactical may connect up to three (3) participants and one (1) audio only call to the telepresence session if MultiSite is enabled for your system.

## Add an incoming call



While in a call and a call request is presented, press the green CALL button to answer that incoming call.



Press the red DISCONNECT button to reject an incoming call.

## Share Content



Pressing the PRESENTATION button will share the contents of a connected PC. Pressing the button again will switch back to showing the Main Camera source.

# Cleaning the System



In general, the unit's case material can be cleaned simply with a mild household detergent. As the case is a plastic product, stiff brushes should be avoided in cleaning the case, as these may scratch the surface.

NOTE: Scratches on the surface of the case will in no way impede its performance.

Please adhere to your organization's guidelines or protocol for handling and cleaning contaminated instruments.

1. Turn the system off -- Disconnect all power cords and adaptors from the electrical power source.
2. Wipe the unit with a clean, soft cloth dampened with a diluted mixture of mild detergent and water.  
  
Squeeze out excess liquid from the cloth.
3. Wipe again with clean, soft cloth dampened with clean water and wipe dry with clean, soft cloth.

NOTE: Use of certain detergents may cause degradation to the labels and plastic components. Consult detergent manufacturer to see if the product is compatible.

NOTE: Do not allow liquid to enter into the display.

---

THE SPECIFICATIONS AND INFORMATION REGARDING THE PRODUCTS IN THIS MANUAL ARE SUBJECT TO CHANGE WITHOUT NOTICE. ALL STATEMENTS, INFORMATION, AND RECOMMENDATIONS IN THIS MANUAL ARE BELIEVED TO BE ACCURATE BUT ARE PRESENTED WITHOUT WARRANTY OF ANY KIND, EXPRESS OR IMPLIED. USERS MUST TAKE FULL RESPONSIBILITY FOR THEIR APPLICATION OF ANY PRODUCTS.

THE SOFTWARE LICENSE AND LIMITED WARRANTY FOR THE ACCOMPANYING PRODUCT ARE SET FORTH IN THE INFORMATION PACKET THAT SHIPPED WITH THE PRODUCT AND ARE INCORPORATED HEREIN BY THIS REFERENCE. IF YOU ARE UNABLE TO LOCATE THE SOFTWARE LICENSE OR LIMITED WARRANTY, CONTACT YOUR CISCO REPRESENTATIVE FOR A COPY.

The Cisco implementation of TCP header compression is an adaptation of a program developed by the University of California, Berkeley (UCB) as part of UCB's public domain version of the UNIX operating system. All rights reserved. Copyright © 1981, Regents of the University of California.

NOTWITHSTANDING ANY OTHER WARRANTY HEREIN, ALL DOCUMENT FILES AND SOFTWARE OF THESE SUPPLIERS ARE PROVIDED "AS IS" WITH ALL FAULTS. CISCO AND THE ABOVE-NAMED SUPPLIERS DISCLAIM ALL WARRANTIES, EXPRESSED OR IMPLIED, INCLUDING, WITHOUT LIMITATION, THOSE OF MERCHANTABILITY, FITNESS FOR A PARTICULAR PURPOSE AND NON-INFRINGEMENT OR ARISING FROM A COURSE OF DEALING, USAGE, OR TRADE PRACTICE.

IN NO EVENT SHALL CISCO OR ITS SUPPLIERS BE LIABLE FOR ANY INDIRECT, SPECIAL, CONSEQUENTIAL, OR INCIDENTAL DAMAGES, INCLUDING, WITHOUT LIMITATION, LOST PROFITS OR LOSS OR DAMAGE TO DATA ARISING OUT OF THE USE OR INABILITY TO USE THIS MANUAL, EVEN IF CISCO OR ITS SUPPLIERS HAVE BEEN ADVISED OF THE POSSIBILITY OF SUCH DAMAGES.

Cisco and the Cisco Logo are trademarks of Cisco Systems, Inc. and/or its affiliates in the U.S. and other countries. A listing of Cisco's trademarks can be found at [www.cisco.com/go/trademarks](http://www.cisco.com/go/trademarks). Third party trademarks mentioned are the property of their respective owners. The use of the word partner does not imply a partnership relationship between Cisco and any other company. (1005R)

Any Internet Protocol (IP) addresses and phone numbers used in this document are not intended to be actual addresses and phone numbers. Any examples, command display output, network topology diagrams, and other figures included in the document are shown for illustrative purposes only. Any use of actual IP addresses or phone numbers in illustrative content is unintentional and coincidental.

On our web site you will find an overview of the worldwide Cisco contacts.

Go to: <http://www.cisco.com/web/siteassets/contacts>



Cisco Systems, Inc.  
170 West Tasman Dr.  
San Jose, CA 95134 USA





## Free Manuals Download Website

<http://myh66.com>

<http://usermanuals.us>

<http://www.somanuals.com>

<http://www.4manuals.cc>

<http://www.manual-lib.com>

<http://www.404manual.com>

<http://www.luxmanual.com>

<http://aubethermostatmanual.com>

Golf course search by state

<http://golfingnear.com>

Email search by domain

<http://emailbydomain.com>

Auto manuals search

<http://auto.somanuals.com>

TV manuals search

<http://tv.somanuals.com>