

Operator's Manual

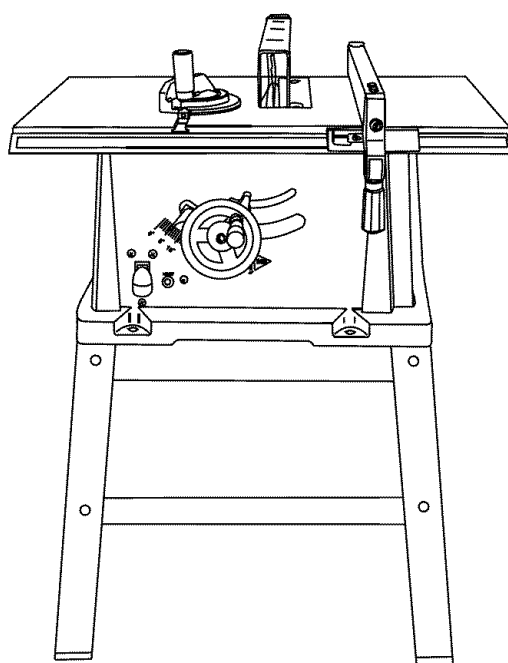

10 in. TABLE SAW WITH LEG SET Model No. 137.218020



CAUTION:

Before using this Table Saw, read this manual and follow all its Safety Rules and Operating Instructions

- Safety Instructions
- Installation
- Operation
- Maintenance
- Parts List

**Customer Help Line
For Technical Support
1-800-843-1682**

**Sears Parts &
Repair Center
1-800-488-1222**

Sears, Roebuck and Co., Hoffman Estates, IL 60179 USA

Visit our Craftsman website: www.sears.com/craftsman

Part No. 137218020001

TABLE OF CONTENTS

SECTION	PAGE	SECTION	PAGE
Warranty	2	Glossary of Terms	9
Product Specifications	2	Assembly and Adjustments	10
Power Tool Safety	3	Operation	18
Table Saw Safety	4	Maintenance	22
Electrical Reuirements and Safety	5	Troubleshooting Guide	23
Carton Content	6	Parts List	24
Know Your Table Saw	8	Push Stick Pattern	28

WARRANTY

ONE-YEAR FULL WARRANTY ON CRAFTSMAN TOOL

If this Craftsman tool fails due to a defect in material or workmanship within one year from the date of purchase, **CALL 1-800-4-MY-HOME® TO ARRANGE FOR FREE REPAIR** (or replacement if repair proves impossible).

If this tool is used for commercial or rental purposes, this warranty will apply for only ninety days from the date of purchase. This warranty applies only while this tool is in the United States.

This warranty gives you specific legal rights, and you may also have other rights, which vary, from state to state.

Sears, Roebuck and Co., Hoffman Estates, IL 60179

PRODUCT SPECIFICATIONS

MOTOR

Type	Universal
Amps	13
Voltage	120
Hz	60
RPM (no load)	4500
Thermal Overload Protection	YES

SAW

Rip Capacity	10-7/8 in L & 9-1/2 in R.
Blade Size	10 in.
Blade Arbor Size	5/8 in.
Maximum Cut Depth @ 90°	3 in.
Maximum Cut Depth @ 45°	2-1/2 in.
Maximum Diameter Dado	6 in. (Stackable only)
Maximum Dado Cut Width	1/2 in.

WARNING

To avoid electrical hazards, fire hazards or damage to the table saw, use proper circuit protection.

This table saw is wired at the factory for 110-120 Volt operation. It must be connected to a 110-120 Volt / 15 Ampere time delay fuse or circuit breaker. To avoid shock or fire, replace power cord immediately if it is worn, cut or damaged in any way.

Before using your table saw, it is critical that you read and understand these safety rules. Failure to follow these rules could result in serious injury to you or damage to the table saw.

POWER TOOL SAFETY

GENERAL SAFETY INSTRUCTIONS

Read and understand all the instructions below before using the power tool. These safety instructions are not meant to cover every possible condition that could occur. As with any power tool, common sense, vigilance and due care must be used.



1. **READ** and become familiar with this entire Operator's Manual. **LEARN** the tool's applications, limitations and possible hazards.
2.  **WARNING**
Look for this symbol that identifies important safety precautions. It means **BE ALERT! YOUR SAFETY IS INVOLVED!**
3. **NEVER OPERATE THIS MACHINE WITHOUT THE SAFETY GUARD IN PLACE FOR ALL THROUGH-SAWING OPERATIONS.**
4. **DO NOT USE IN A DANGEROUS ENVIRONMENT** such as damp or wet locations or in the rain. Keep work area well lighted.
5. **DO NOT** use power tools in the presence of flammable liquids or gases.
6. **KEEP WORK AREA CLEAN.** Cluttered areas and benches invite accidents.
7. **KEEP CHILDREN AWAY.** All visitors should be kept at a safe distance from the work area.
8. **DO NOT FORCE THE TOOL.** It will do the job better and safer if used at the rate for which it was designed.
9. **USE THE RIGHT TOOL.** Do not force the tool or attachment to do a job for which it is not designed.
10. **WEAR PROPER APPAREL. DO NOT** wear loose clothing, gloves, neckties, rings, bracelets or other jewelry that may get caught in moving parts. Non-slip footwear is recommended. Wear protective hair covering to contain long hair.
11. **WEAR A FACE MASK OR DUST MASK.** Sawing, cutting and sanding operations produce dust.
12. **DISCONNECT TOOLS** before servicing and when changing accessories, such as blades, cutters, etc.
13. **REDUCE THE RISK OF UNINTENTIONAL STARTING.** Make sure the switch is in the OFF position before plugging tool into the power supply.
14. **USE ONLY RECOMMENDED ACCESSORIES.** Consult the Operator's Manual for recommended accessories. The use of improper accessories may cause injury to you or damage to the tool.
15. **REMOVE ADJUSTING KEYS AND WRENCHES.** Form the habit of checking to see that keys and adjusting wrenches are removed from the tool before turning ON.
16. **NEVER LEAVE TOOL RUNNING UNATTENDED. TURN THE POWER OFF.** Do not leave the tool before the blade comes to a complete stop.
17. **NEVER STAND ON TOOL.** Serious injury could occur if the tool is tipped or if the cutting tool is unintentionally contacted.
18. **DO NOT OVERREACH.** Keep proper footing and balance at all times.
19. **MAINTAIN TOOLS WITH CARE.** Keep tools sharp and clean for most efficient and safest performance. Follow instructions for lubricating and changing accessories.
20. **CHECK FOR DAMAGED OR LOOSE PARTS.** Check for alignment of moving parts, binding of moving parts, loose mounting and any other conditions that may affect its safe operation. A guard or other part that is loose or damaged should be properly adjusted, repaired or replaced.
21. **MAKE WORKSHOP CHILDPROOF** with padlocks, master switches or by removing starter keys.
22. **DO NOT** operate the tool if you are under the influence of any drugs, alcohol or medication that could impair your ability to use the tool safely.
23. **USE A DUST COLLECTION SYSTEM** whenever possible. Dust generated from certain materials can be hazardous to your health and, in some cases, a fire hazard. Always operate the power tool in a well-ventilated area with adequate dust removal.
24. **ALWAYS WEAR EYE PROTECTION.** Any power tool can throw debris into your eyes that could cause permanent eye damage. **ALWAYS** wear safety goggles (not glasses) that comply with ANSI safety standard Z87.1. Everyday glasses have only impact resistant lenses. They **ARE NOT** safety glasses.
NOTE: Glasses or goggles not in compliance with ANSI Z87.1 could cause serious injury when they break.
25. **DIRECTION OF FEED.** Feed work into a blade or cutter against the direction of rotation of the blade or cutter only.
26. **DO NOT** loan your tool to a neighbor or friend without providing him/her with the Operator's Manual. Be sure he/she learns the tool's applications and possible hazards.

TABLE SAW SAFETY

1. **ALWAYS USE SAW BLADE GUARD**, splitter and anti-kickback pawls for every through-sawing operation. Through-sawing operations are those in which the blade cuts completely through the workpiece when ripping or crosscutting. Always be sure blade guard is tightened securely.
2. **ALWAYS HOLD WORK FIRMLY** against the miter gauge or rip fence.
3. **ALWAYS USE** a push stick, especially when ripping narrow stock. Refer to ripping instructions in this Operator's Manual where the push stick is covered in detail. A pattern for making your own push stick is included on page 28.
4. **NEVER PERFORM ANY OPERATION FREEHAND, which means using only your hands to support or guide the workpiece. Always use either the fence or the miter gauge to position and guide the work.**

FREEHAND CUTTING IS THE MAJOR CAUSE OF KICKBACK AND FINGER/HAND AMPUTATIONS. NEVER USE THE MITER GAUGE AND FENCE SIMULTANEOUSLY.
5. **NEVER STAND** or have any part of your body in line with the path of the saw blade. Keep your hands out of the saw blade path.
6. **NEVER REACH** behind or over the cutting tool for any reason.
7. **REMOVE** the rip fence when crosscutting.
8. **DO NOT USE** a molding head with this saw.
9. **FEED WORK INTO THE BLADE** against the direction of rotation only.
10. **NEVER** use the rip fence as a cut-off gauge when crosscutting.
11. **NEVER ATTEMPT TO FREE A STALLED SAW BLADE** without first turning the saw OFF. Turn power switch OFF immediately to prevent motor damage.
12. **PROVIDE ADEQUATE SUPPORT** to the rear and the sides of the saw table for long or wide workpieces.
13. **AVOID KICKBACKS** (work thrown back towards you) by keeping the blade sharp, the rip fence parallel to the saw blade and by keeping the splitter, anti-kickback pawls and guards in place, aligned and functioning. Do not release work before passing it completely beyond the saw blade. Do not rip work that is twisted, warped or does not have a straight edge to guide it along the fence. Do not attempt to reverse out of a cut with the blade running.
14. **AVOID AWKWARD OPERATIONS** and hand positions where a sudden slip could cause your hand to move into the saw blade.
15. **NEVER USE SOLVENTS** to clean plastic parts. Solvents could possibly dissolve or otherwise damage the material. Only a soft damp cloth should be used to clean plastic parts.
16. **MOUNT** your table saw on a bench or stand before performing any cutting operations. Refer to ASSEMBLY on page 10.
17. **NEVER CUT METALS** or materials that may make hazardous dust.
18. **ALWAYS USE IN A WELL-VENTILATED AREA.** Remove sawdust frequently. Clean out sawdust from the interior of the saw to prevent a potential fire hazard.
19. **NEVER LEAVE THE SAW RUNNING UNATTENDED.** Do not leave the saw until the blade comes to a complete stop.
20. **FOR PROPER OPERATION** follow the instructions in this Operator's Manual entitled OPERATION (Page 18).

NOTE: On machines with no stand or if stand is not being used, a hole approximately 11 in. square must be cut under saw to allow sawdust to fall through. Failure to cut this hole will allow sawdust to build up in the motor area, resulting in a fire hazard and potential motor damage.

ELECTRICAL REQUIREMENTS AND SAFETY

GROUNDING INSTRUCTIONS

IN THE EVENT OF A MALFUNCTION OR BREAKDOWN, grounding provides a path of least resistance for electric currents and reduces the risk of electric shock. This tool is equipped with an electrical cord that has an equipment-grounding conductor and a grounding plug. The plug must be plugged into a matching receptacle that is properly installed and grounded in accordance with all local codes and ordinances.

DO NOT MODIFY THE PLUG PROVIDED. If it will not fit the receptacle, have the proper receptacle installed by a qualified electrician.

IMPROPER CONNECTION of the equipment grounding conductor can result in risk of electric shock. The conductor with the green insulation (with or without yellow stripes) is the equipment grounding conductor. If repair or replacement of the electrical cord or plug is necessary, do not connect the equipment grounding conductor to a live terminal.

CHECK with a qualified electrician or service person if you do not completely understand the grounding instructions, or if you are not certain the tool is properly grounded.

USE only three-wire extension cords that have three-pronged grounding plugs with three-pole receptacles that accept the tool's plug. Repair or replace damaged or worn cords immediately.

GUIDELINES FOR EXTENSION CORDS

USE THE PROPER EXTENSION CORD. Make sure your extension cord is in good condition. Use an extension cord heavy enough to carry the current your product will draw. An undersized cord will cause a drop in line voltage resulting in loss of power, overheating and burning out of the motor. The table on the right shows the correct size to use depending on cord length and nameplate ampere rating. If in doubt, use the next heavier gauge. The smaller the gauge number, the heavier the cord.

Make sure your extension cord is properly wired and in good condition. Always replace a damaged extension cord or have it repaired by a qualified technician before using it. Protect your extension cords from sharp objects, excessive heat and damp or wet areas.

Use a separate electrical circuit for your tool. This circuit must not be less than #12 wire with a 20 A time-lag fuse

or a #14 wire with a 15 A time-lag fuse. **NOTE:** When using an extension cord on a circuit with a #14 wire, the extension cord must not exceed 25 feet in length. Before connecting the motor to the power line, make sure the switch is in the off position and the electric current is rated the same as the current stamped on the motor nameplate. Running at a lower voltage will damage the motor. This tool is intended for use on a circuit that has a receptacle like the one illustrated in Fig. 1.

Fig. 1 shows a three-pronged electrical plug and receptacle that has a grounding conductor. If a properly grounded receptacle is not available, an adapter (Fig. 2) can be used to temporarily connect this plug to a two-contact grounded receptacle. The adapter (Fig. 2) has a rigid lug extending from it that **MUST** be connected to a permanent earth ground, such as a properly grounded receptacle box.

CAUTION
In all cases, make certain the receptacle is properly grounded. If you are not sure, have a qualified electrician check the receptacle.

CAUTION
This tool is for indoor use only. Do not expose to rain or use in damp locations.

Fig. 1

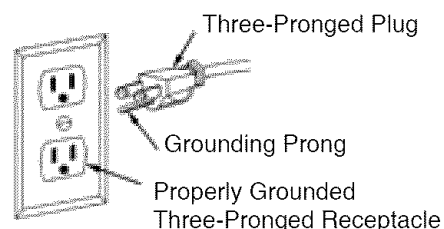
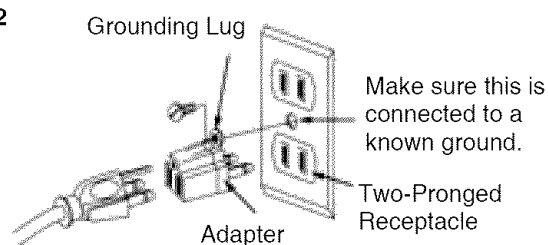

Fig. 2



CAUTION
This tool must be grounded while in use to protect the operator from electric shock.

MINIMUM GAUGE FOR EXTENSION CORDS (AWG)

(When using 120 volts only)					
Ampere Rating		Total length of Cord			
More Than	Not More Than	25ft.	50ft.	100ft.	150ft.
0	6	18	16	16	14
6	10	18	16	14	12
10	12	16	16	14	12
12	16	14	12	Not Recommended	

ACCESSORIES AND ATTACHMENTS

RECOMMENDED ACCESSORIES

⚠ WARNING

Visit your Sears Hardware Department or see the Craftsman Power and Hand Tools Catalog to purchase recommended accessories for this power tool.

⚠ WARNING

To avoid the risk of personal injury:

- Do not use adjustable (wobble) type dados or carbide tipped dado blades.
- Use only stackable dado blades.
- Maximum dado width is 1/2 in.
- Do not use a dado with a diameter larger than 6 in.
- Do not use molding head set with this saw.
- Do not modify this power tool or use accessories not recommended by Sears.

TOOLS NEEDED FOR ASSEMBLY

NOT SUPPLIED

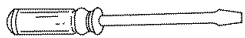

Medium screwdriver



Adjustable wrench

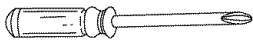

#2 Phillips screwdriver

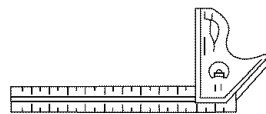

Combination square



Straight edge

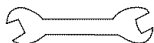

13 mm wrench

CARTON CONTENTS

Separate all parts from packing materials. Check each part with the illustration on the next page and the "Table of Loose Parts" to make certain all items are accounted for, before discarding any packing material.

⚠ WARNING

If any part is missing or damaged, do not attempt to assemble the table saw, plug in the power cord, or turn the switch ON until the missing or damaged part is obtained and is installed correctly.

TABLE OF LOOSE PARTS

<u>ITEM</u>	<u>DESCRIPTION</u>	<u>QUANTITY</u>
A.	Table saw assembly	1
B.	Blade	1
C.	Blade wrenches	2
D.	Miter gauge	1
E.	4mm Hex key	1
F.	Guard mounting bolt, flat washer, Toothed washer, oval washer, Spring washer	1
G.	Blade guard and splitter	1
H.	Rip fence, lock handle & nut	1
I.	Flat washer & dome nut	1
J.	Handwheel	1

STAND

K.	Short upper support	2
L.	Long upper support	2
M.	Short bottom support bracket	2
N.	Long bottom support bracket	2
O.	Leg	4
P.	Foot Pad	4
Q.	Stand mounting hardware bag	1

NOTE: To make assembly easier, keep contents of box together. Apply a coat of automobile wax to the table. Wipe all parts thoroughly with a clean dry cloth. This will reduce friction when pushing the workpiece. To avoid injury, the styrofoam block should be removed between the motor and the table.

UNPACKING YOUR TABLE SAW

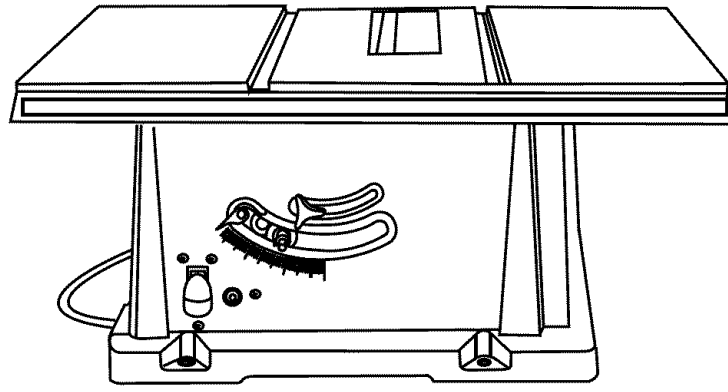

A

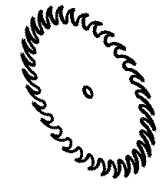

B



C

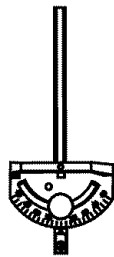

D



E

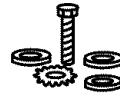

F

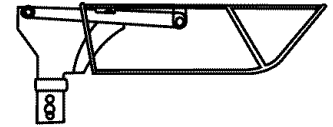

G

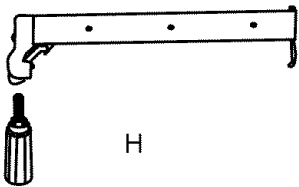

H



I

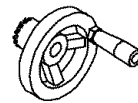

J

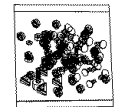

Q

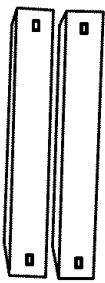

K



L



M



N

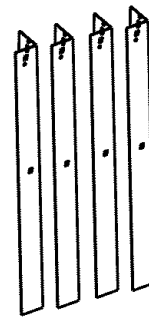

O



P

KNOW YOUR TABLE SAW

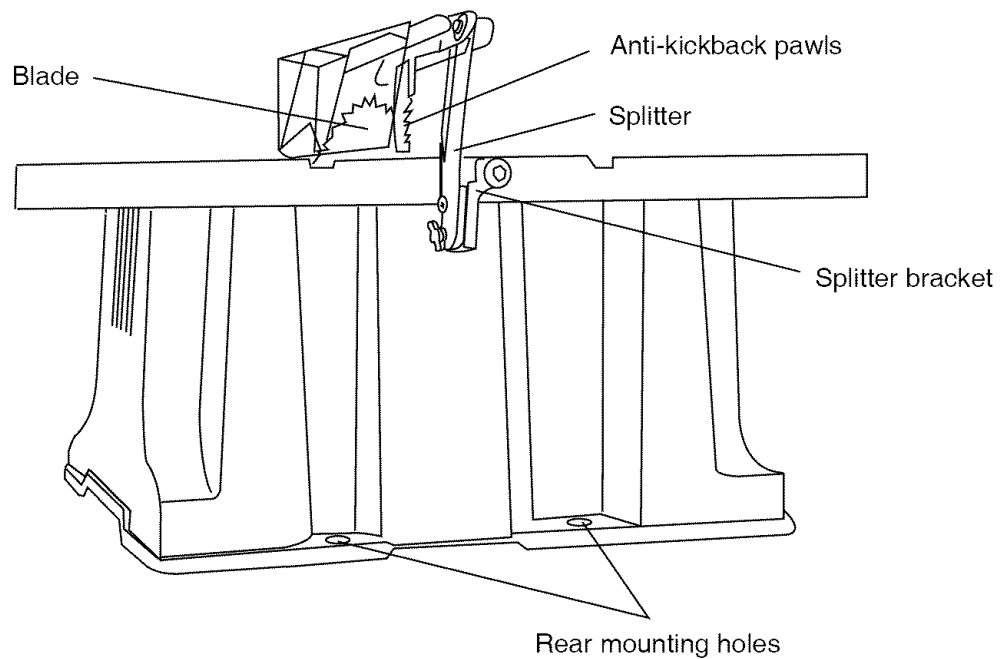
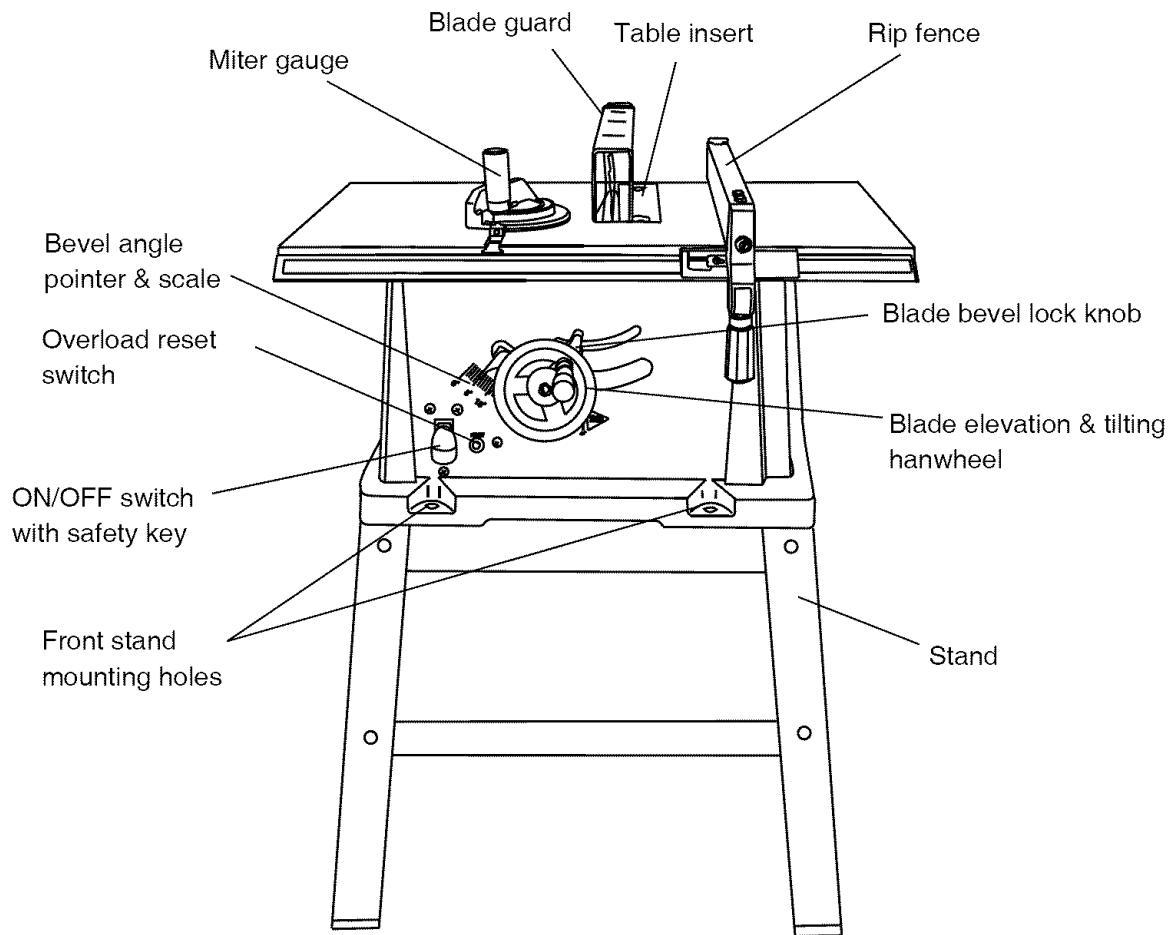

GLOSSARY OF TERMS

ANTI-KICKBACK PAWLS – Prevents the workpiece from being kicked upward or back toward the front of the table saw by the spinning blade.

ARBOR – The shaft on which the blade or dado is mounted.

BEVEL CUT – An angle cut made through the face of the workpiece.

BLADE BEVEL SCALE – Measures the angle the blade is tilted when set for a bevel cut.

BLADE ELEVATION/TILTING HANDWHEEL – Raises and lowers the blade. Tilts the blade to any angle between 0° and 45° for bevel cuts.

BLADE GUARD – Clear plastic cover that is positioned over the blade while cutting.

COMPOUND CUT – A simultaneous bevel and miter cut.

CROSSCUT – A cut made across the width of the workpiece.

DADO – Special cutting blades that are used to cut grooves in a workpiece.

DUST PORT – Hole in back of saw base for attachment of vacuum hose.

FREEHAND – Performing a cut without using a rip fence, miter gauge, hold down or other proper device to prevent the workpiece from twisting during the cutting operation.

GUM – A sticky sap from wood products.

HEEL – Misalignment of the blade.

JAM NUT – Nut used to lock another nut in place on a threaded rod or bolt.

KERF – The amount of material removed by the blade cut.

MITER CUT – An angle cut made across the width of the workpiece.

MITER GAUGE – A guide used for crosscutting operations that slides in the table top channels (grooves)

located on either side of the blade. It helps make accurate straight or angle crosscuts.

OVERLOAD RESET SWITCH – Resets the thermocouple and provides a way to restart the saw motor if it overloads or overheats.

PUSH STICK – Accessory that is used to push the workpiece through the cut to avoid placing your hands close to the blade.

RESIN – A sticky sap that has hardened.

REVOLUTIONS PER MINUTE (RPM) – The number of turns completed by a spinning object in one minute.

RIP FENCE – A guide used for rip cutting that clamps to the table top. It allows the workpiece to cut straight.

RIPPING – Cutting with the grain of solid wood or along the length of the workpiece.

SAW BLADE PATH – The area of the workpiece or table top directly in line with the travel of the blade, or the part of the workpiece that will be cut.

SET – The distance between two saw blade tips, bent outward in opposite directions to each other. The farther apart the tips are, the greater the set.

SPLITTER – Keeps the workpiece split apart after being cut to prevent binding on the blade and workpiece.

TABLE INSERT – Insert that is removed from the table to install/remove blades. It is also removed for dado cutting. When dado cutting, a dado insert plate must be used.

THROUGH-SAWING – Making a cut completely through the length or width of a workpiece.

WORKPIECE – Material to be cut.

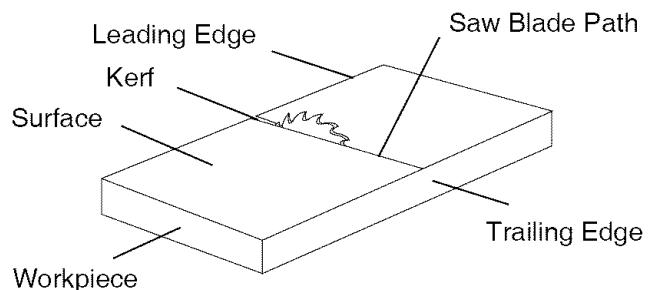

ASSEMBLY AND ADJUSTMENTS

ASSEMBLE STAND (FIG. A)

1. Unpack all parts and group by type and size. Refer to the parts list for correct quantities.
2. Attach one long upper support (P) to top of leg (S) using one bolt (1) and nut (2).
NOTE: Do not tighten bolts until stand is properly aligned (see step #8 before tightening).
3. Attach other end of long upper support to top of another leg using one bolt and nut.
4. Attach one long bottom support (R) to center of each leg using bolt (1) and nut (2). This completes the front frame section.
5. Assemble rear frame section in exactly the same manner.
6. Join front and rear frame assemblies using two short upper supports (O) and two short bottom supports (Q), bolts and nuts.
7. Insert foot pad (T) into bottom of leg. Repeat for each leg.
8. Place stand on level surface and adjust so all legs are contacting the floor and are at similar angles to the floor, and detents in stand leg align with support brackets, then tighten all bolts.

NOTE: Stand should not rock after all bolts are tightened.

Fig. A

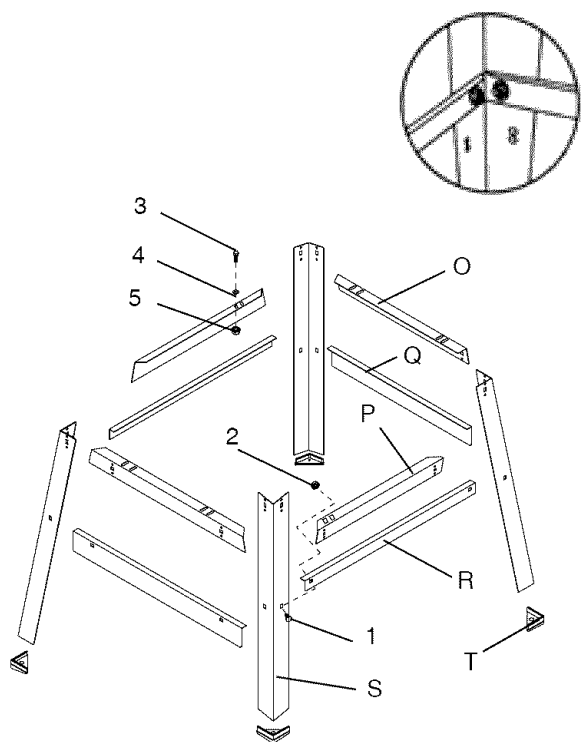

ASSEMBLE TABLE SAW TO STAND (FIG. A-1)

1. Place protective cardboard or old blanket on floor to protect the saw table surface.
2. Place the saw up side down on the protective material (see Fig. A-1).
3. Position the stand up side down on the saw base.
NOTE: Make sure front of stand and front of saw are facing the same direction.
4. Line up the four holes in saw base and stand.
5. Fasten saw to stand using four bolts (3), washers (4) and nuts (5).
NOTE: Place washer on each bolt before inserting into saw base and through the support. Nut must be immediately against the bracket (see Fig. A).
6. Carefully set the saw in its upright position on a clean level surface.
7. Tighten all four nuts.

NOTE: DO NOT OVER TIGHTEN NUTS HOLDING SAW TO STAND. THIS MAY DAMAGE THE SAW BASE.

⚠ WARNING

IF THE STAND WILL NOT BE USED, DO NOT OPERATE THE TABLE SAW ON THE FLOOR. THIS IS A VERY DANGEROUS POSITION.

Fig. A-1

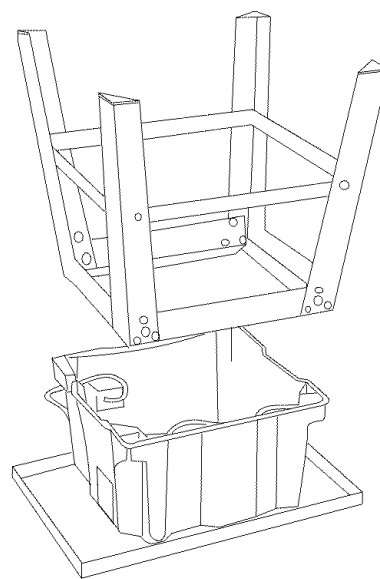

SAW MOUNTED TO WORK SURFACE (FIG.B)

1. If the leg set will not be used, the saw must be properly secured to a sturdy workbench using the four mounting holes at the base of the saw.
2. The surface of the table where the saw is to be mounted must have a hole large enough to facilitate sawdust fall-through and removal.
3. Square the saw on the mounting surface and mark the location of the four 3/8 in. mounting holes (1).
4. Drill 3/8 in. hole into the mounting surface.
5. Mark an 11 in. square (2) centered between the four mounting holes (1).
6. Cut out and remove the square.
7. This opening will allow sawdust to fall through the saw base.
8. Place the saw on the work surface, and align the mounting holes of the saw with those drilled through the surface.
9. Fasten the saw to the work surface.

⚠ WARNING

Do not operate this machine on the floor. This is very dangerous and may cause serious injury.

Fig. B

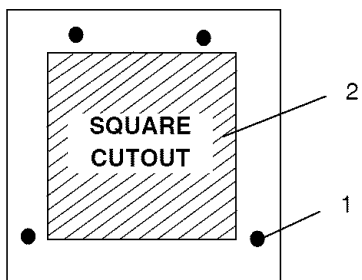

⚠ WARNING

Failure to provide the sawdust fall-through hole for use of the saw when mounted to a worksurface and not a stand will cause sawdust to build up in the motor area, which may result in fire or cause motor damage.

KEEPING THE AREA CLEAN

1. Sawdust and wood chips that fall from under the saw will accumulate on the floor.
2. Make it a practice to pick up and discard this dust when you have completed cutting.

ASSEMBLE BLADE RAISING & TILTING WHEEL (FIG. C)

1. Attach blade raising and tilting hand wheel (1) to the height regulating bolt (2). Make sure the slot (3) in the hand wheel hub is engaged with the roll pin (4) in the height regulating bolt.
2. Fasten hand wheel to height regulating bolt with flat washer (5) and dome nut (6).

Fig. C

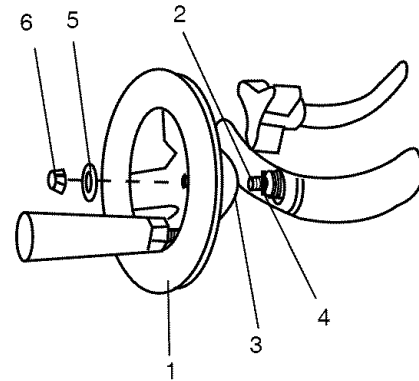

RIP FENCE (FIG. D, E)

1. Thread the rip fence locking handle (2) into the eccentric (3) of the fence and lock in place by tightening the nut (1) against the fence head.

Fig. D

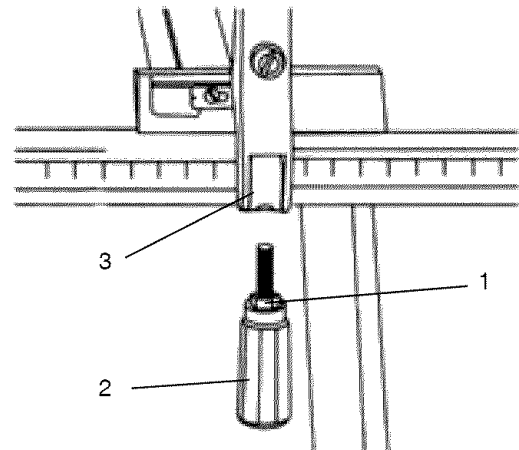

2. Lift upward on rip fence handle (2) so the rear holding clamp (4) is fully extended.
3. Place the rip fence on the saw table (5), engaging the rear fence clamp first then lowering the front end onto the table.
4. Push down on the fence handle (2) to lock.

Fig. E

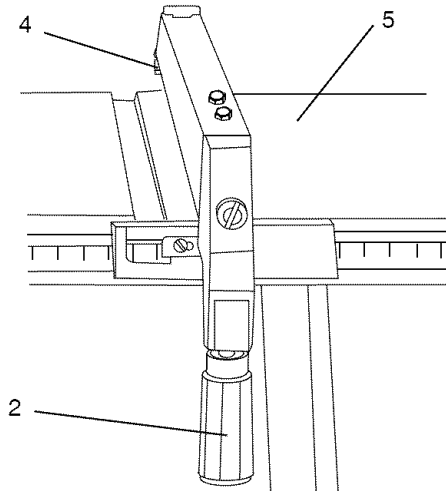
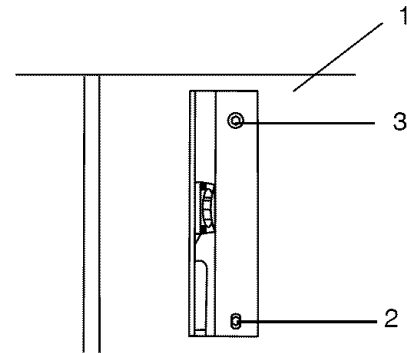

Fig. H



2. Raise the blade arbor (4) (Fig. I) to the maximum height by turning the blade raising handwheel counterclockwise.
3. Place the open-end wrench (8) jaws on the flats of the saw arbor to keep the arbor from turning (Fig. J) and place the box-end wrench (9) on the arbor nut (5), and turn counterclockwise.
4. Remove the arbor nut (5) and outer flange (6) (Fig. I).

INSTALLING AND CHANGING THE BLADE (FIG. H, I, J)

⚠ DANGER

- To avoid injury from an accidental start, make sure the switch is in the OFF position and the plug is not connected to the power source outlet.
 - To avoid serious injury, the rear of the table insert must be level with the table. If the rear of the insert is not level with the table, adjust the screw (3) in or out until the rear of the insert is level to or slightly above the table. To raise the insert, turn the screw counterclockwise, to lower the insert, turn the screw clockwise. **NOTE: A rubber adjusting spacer is provided under rear of insert for this purpose.**
1. Remove the table insert (1) by removing the two screws (2, 3). Be careful not to lose the rubber spacer that is on the back screw (3) beneath the table insert (Fig. H).

5. Install the saw blade onto the arbor with the blade teeth pointing toward the front of the saw.
6. Install the flange (6) against the blade and thread the arbor nut (5) as far as possible by hand. Ensure that the blade is flush against the inner side of the blade flange.

⚠ WARNING

To avoid possible injury and damage to the workpiece, be sure to install the blade with the teeth pointing toward the front of table in the direction of the rotation arrow on the blade guard.

Fig. I

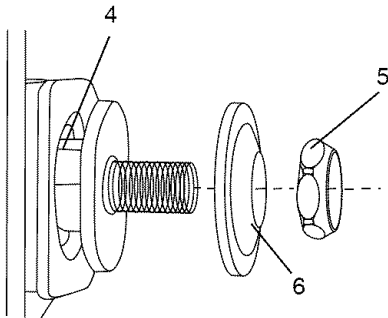

7. To tighten the arbor nut (5) place the open-end wrench (8) on the flats of the saw arbor to keep the arbor from turning (Fig. J).
8. Place the box-end wrench (9) on the arbor nut (5), and turn clockwise (to the rear of the saw table).
9. Replace the blade insert in the table recess, insert the screws through the front and rear holes and tighten remembering the rubber washer under the rear of the insert and leveling the rear of the insert to the table.

Fig. J

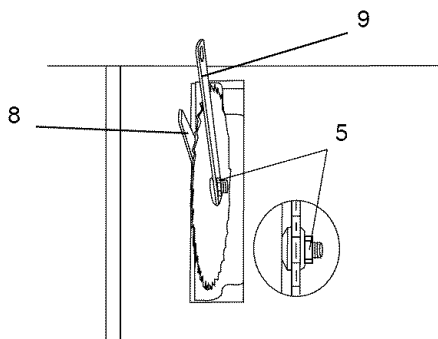

⚠ WARNING

To avoid injury from a thrown workpiece, blade parts, or blade contact, never operate saw without the proper insert in place. Use the original installed insert for all through sawing operations except dado cuts. A special dado insert plate must be installed when using a dado blade.

BLADE GUARD ASSEMBLY (FIG. K, L, M)

1. Set the blade to maximum height and the tilt to zero degrees on the bevel scale with the hand wheels. Lock the blade bevel lock knob.
2. Place the spring washer (2), flat washer (3), external tooth lock washer (4) onto the blade guard mounting bolt (1) (Fig. K).
3. Insert bolt and washer assembly through splitter bracket (5).

Fig. K

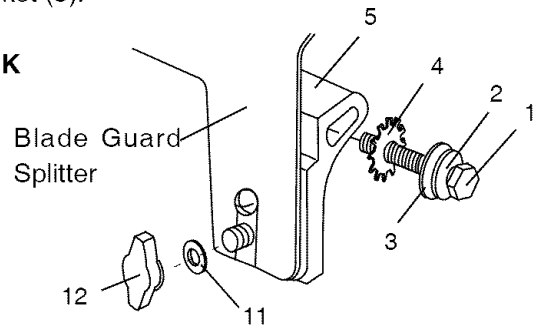

4. Place the oval washer (6) on the pivot rod (7) (Fig. L).
5. Install the blade guard splitter & bracket assembly into the rear of the saw table. Thread the bolt (1) into the internally threaded pivot rod until snug.

NOTE: The blade guard and splitter is removed from the illustration for clarity.

Fig. L

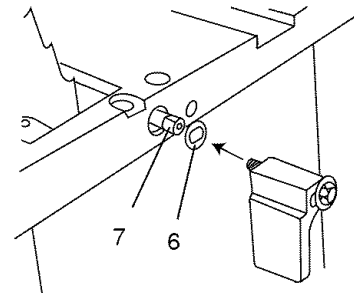

6. Lift blade guard arm (8) up and using a straight edge, align the blade guard splitter (9) with the saw blade (10).
7. Shift the splitter bracket assembly to right or left until parallel alignment to the blade is achieved.
8. When the splitter is properly aligned with the saw blade, tighten the bolt securely.

NOTE: The splitter bracket must always be correctly aligned so the cut workpiece will pass on either side without binding or twisting.

⚠ WARNING

See Fig. K flat washer (11) must be under knob (12). **NOTE:** Be sure to tighten knob very tight and periodically check tightness.

⚠ DANGER

Improper splitter alignment can cause “kickback” and serious injury.

Fig. M

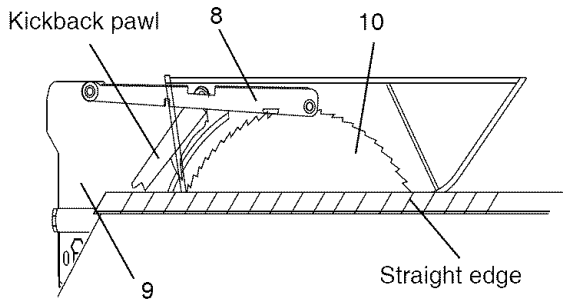

MITER GAUGE ADJUSTMENT (FIG. N)

1. To check miter gauge squareness, loosen lock handle (1) to allow miter body (3) to rotate freely. Position the miter head so the pointer (2) points to 90° on the scale. Tighten lock handle to hold miter head in position. Use a square to verify the 90° angle between the miter body and the slide bar.
2. If adjustment is needed, square the miter head to 90°, loosen the pointer locking screw and adjust pointer to 90° on the protractor scale then tighten the locking screw.
3. To change angles on miter gauge, loosen lock handle (1) and rotate miter body to desired angle as indicated by the pointer (2). Secure in position by tightening the lock handle.

Fig. N

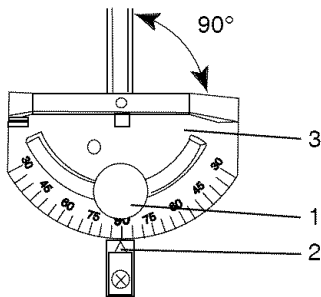

RIP FENCE ADJUSTMENT (FIG. O)

1. The fence (1) is moved by lifting up on the locking handle (2) and sliding the fence to the desired location. Pushing down on the handle locks the fence in position.
2. Position the fence on the table and along one edge of the miter gauge grooves.
3. Lock the fence handle. The fence should be parallel with the miter gauge groove.

4. If adjustment is needed to make the fence parallel to the groove, proceed with the following adjustments:
 - Loosen the two bolts (3) and lift up on the handle (2).
 - Hold the fence bracket (4) firmly against the front of the saw table. Move the far end of the fence until it is parallel with the miter gauge groove.
 - Push the handle to lock, then tighten both bolts.
5. If fence is loose when the handle is in the locked (downward) position, proceed with the following adjustment:
 - Lift the handle (2) upward and turn the adjusting screw (5) clockwise until the bottom of the rear clamp is 1/16 in. away from the rear of the table.

NOTE: Over-tightening the adjusting screw will cause the fence to come out of alignment.

⚠ WARNING

Failure to properly align fence can cause “kickback” and serious injury.

NOTE: The rip fence and blade are aligned parallel to the miter gauge groove of the table.

Fig. O

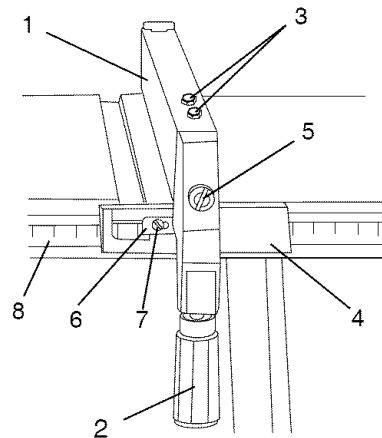

RIP FENCE INDICATOR ADJUSTMENT (FIG. O)

1. The rip fence indicator (6) points to the rip scale (8). The scale references the distance between the fence and the blade.
2. Measure the actual distance with a rule. If there is a difference between the measurement and the indicator, adjust the indicator (6).
3. Loosen the screw (7) and slide the indicator to the correct measurement on the scale. Tighten the screw and re-measure.

BLADE TILTING MECHANISM

The saw blade can be tilted two different ways.

RAPID BLADE TILTING (FIG. P)

1. Loosen blade bevel lock knob (2).
2. Slide the entire handwheel assembly (1) to desired location.
3. Tighten locking knob (2). Ensure locking knob is fully tightened before attempting a cut.

MICRO-ADJUSTMENT BLADE TILTING (FIG. P)

1. Loosen blade bevel lock knob (2).
2. Push handwheel (1) IN to engage the handwheel gears with the segment gear on the table saw base.
3. While holding handwheel IN, turn the handwheel to tilt the blade to the desired angle.
4. Tighten lock knob to secure bevel angle.
NOTE: Changing the blade angle can be done independently of changing blade height.

⚠ WARNING

BLADE BEVEL LOCK KNOB (1) MUST BE FIRMLY TIGHTENED AND LOCKED DURING ALL CUTTING OPERATIONS.

Fig. P

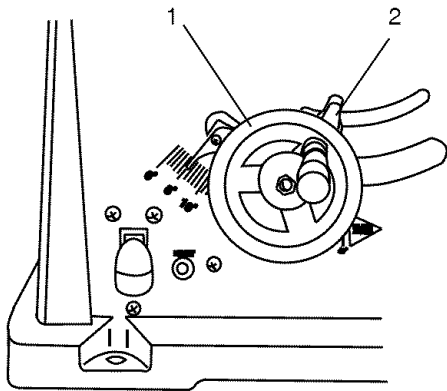

BLADE HEIGHT ADJUSTMENT (FIG. P)

To raise the saw blade, turn handwheel (1) COUNTERCLOCKWISE. To lower the blade, turn the handwheel CLOCKWISE.

It is not necessary to loosen blade tilting locking knob (2) when raising or lowering the saw blade.

BLADE PARALLEL TO THE MITER GAUGE GROOVE (FIG. Q, R)

This adjustment was made at the factory, but it should be rechecked and adjusted if necessary.

⚠ WARNING

- To prevent personal injury:
Always disconnect plug from the power source when making any adjustments.
- This adjustment must be correct or kickback could result in a serious injury and accurate cuts can not be made.

1. Remove the safety switch key and unplug the saw.
2. Remove the blade guard for this procedure but reinstall and realign after adjustment.
3. Raise the blade to the highest position and set at the 0° angle (90° straight up).
4. Select and mark, with a felt tip maker, a blade tooth having a "right set" and rotate the blade so the marked tooth is ½ in. above the table at the front of the saw.
5. Place the combination square base (1) into the right side miter gauge groove (2).
6. Adjust the rule so it touches the front marked tooth and lock ruler so it holds its position in the square assembly.
7. Rotate the blade bringing the marked tooth to the rear and about ½ in. above the table.
8. Carefully slide the combination square to the rear until the ruler touches the marked tooth.
9. If the ruler touches the marked tooth at the front and rear position indicating the same measurement, no adjustment is needed at this time. If not perform adjustment procedure described in next section.

Fig. Q

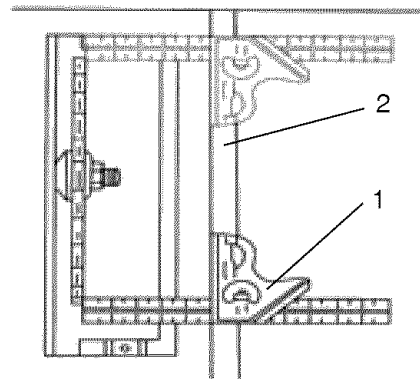

ADDITIONAL BLADE ADJUSTMENTS (FIG. R)

TOOLS REQUIRED

- 10 mm open end or 10 mm combination wrench
- 4 mm hex key
- Framing square
- Medium size flat blade screw driver

ADJUSTMENT PROCEDURE

1. Turn saw switch OFF and remove plug from the power source.
2. Remove blade guard and splitter assembly, miter gauge and rip fence.
3. Using the 10 mm hex wrench, slightly loosen the two middle blade alignment rod strap bolts (1) and two rear blade alignment rod strap bolts (2) located on the underside of the saw table. (Fig. R)

Fig. R

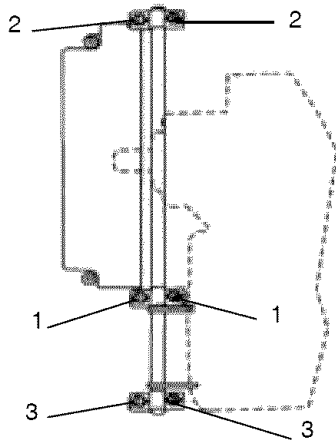

4. While standing at the rear of the saw, use a medium size flat blade screwdriver and gently pry the rear of the blade alignment rod to the LEFT or RIGHT. Using the framing square, simultaneously measure the distance at the front and rear of the blade to an edge of a miter slot. When the distances are within 1/64 in. or closer, tighten both rear blade alignment rod strap bolts (2) while holding the rod firmly in place. **NOTE:** The blade alignment rod will only move slightly.
5. If alignment is not achieved by rear adjustment, loosen the two front blade alignment rod strap bolts (3).
6. While standing at the front of the saw, use a medium size flat blade screw driver and gently pry the front of the blade alignment rod to the RIGHT or LEFT. Simultaneously measure the distance at the front and rear of the blade to an edge of a miter slot. When the distances are within 1/64 in. or closer, tighten both front blade alignment rod strap

bolts (3) while holding the rod firmly in place.

NOTE: The blade alignment rod will only move slightly to the right.

7. Tighten both middle blade alignment rod strap bolts (1). **NOTE:** Re-check to make sure all six bolts are properly tightened and that the distance from the front and rear of the blade to the miter gauge groove are within 1/64th of an inch from one another.
8. Re-install blade guard and splitter assembly and adjust the alignment with the blade as outlined earlier in the operator's manual.

0° BEVEL STOP (FIG. S)

1. Raise the blade to maximum height by rotating the handwheel counterclockwise.
2. Loosen bevel angle lock knob.
3. Tilt the blade to 0° bevel.
4. Using a square (1), verify blade is 90° to the table top.
5. If blade is not 90° to the table, back off the adjustment screw (2) .
6. Loosen bevel lock knob and square blade 90° to the table.
7. Once blade is at 90° to the table top, lock bevel angle locking knob.
8. Carefully tighten adjusting screw (2) until it touches the bevel stop. **DO NOT OVER TIGHTEN.**
9. Recheck to ensure blade is still aligned at 90°.

Fig. S

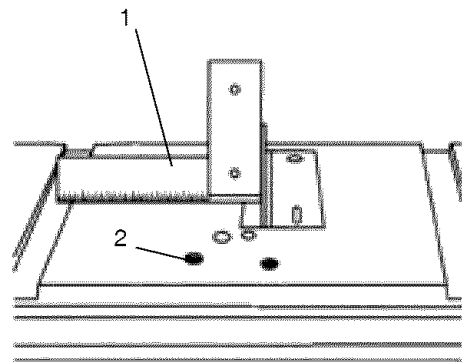

BEVEL POINTER ADJUSTMENT (FIG. T)

When you have achieved a 90° angle of the blade to the table top as described in section above, the angle pointer (1) may require adjustment. If so, follow proceeding steps:

1. Loosen pointer screw (2) and move the pointer (1) so it is aligned with 0° on the bevel scale.
2. Retighten the pointer screw.

Fig. T

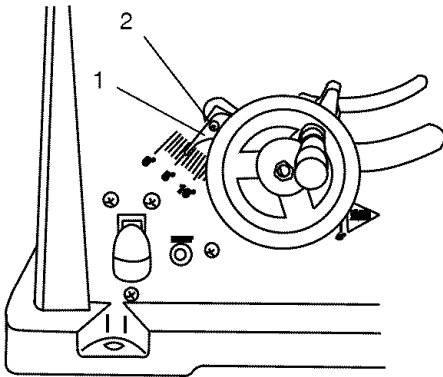

45° BEVEL STOP (FIG. U)

1. Raise the blade to maximum height by rotating the handwheel counterclockwise.
2. Loosen bevel angle lock knob.
3. Tilt the blade to 45° bevel.
4. Using a square (1), verify blade is 45° to the table top.
5. If blade is not 45° to the table, back off the adjustment screw (2).
6. Loosen bevel lock knob and square blade 45° to the table.
7. Once blade is at 45° to the table top, lock bevel angle locking knob.
8. Carefully tighten adjusting screw (2) until it touches the bevel stop. DO NOT OVER TIGHTEN.
9. Recheck to ensure blade is still aligned at 45°.

Fig. U

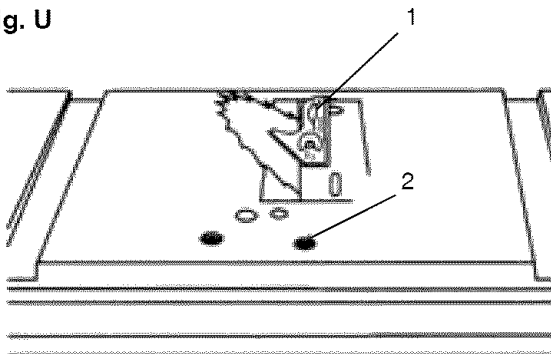

OPERATION

BASIC SAW OPERATIONS

ON/OFF SWITCH (FIG. V)

The on/off switch (1) is located on the front panel of the saw base. To turn the saw ON, move the switch to the up position. To turn the saw OFF, move the switch to the down position.

LOCKING SWITCH IN “OFF” POSITION (FIG. V)

When the saw is not in use, the switch should be locked in the OFF position. To lock the switch in the OFF position, pull out the safety key (2) from of the switch. The saw will not start with the key removed. However, if the key is removed while the switch is in the ON position, it can be turned off ONCE. The saw will not restart until the key has been reinserted into the switch and the switch is turned on.

OVERLOAD PROTECTION (FIG. V)

This saw is equipped with an overload reset switch. If the motor shuts off or fails to start due to overloading or low voltage, turn the switch to OFF position and let the motor cool down and remove all cutting materials from the saw. After the motor has cooled down, push the reset button (3) to reset the overload device. The saw should now start when the switch is returned to the ON position.

To avoid injury, the ON/OFF switch should be in the OFF position and the plug removed from the power source while the motor cool down takes place. This will prevent accidental starting when the reset button is pushed. Overheating may be caused by misaligned parts, a dull blade, or an undersized extension cord. Inspect the saw for proper setup before using it again.

Fig. V

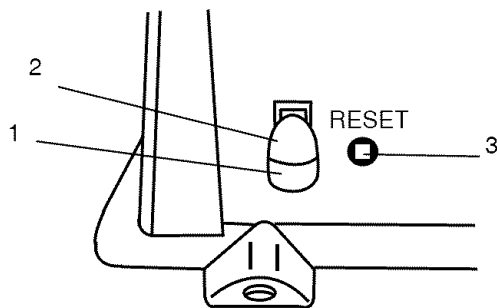

CUTTING OPERATIONS

There are two basic types of cuts: ripping and crosscutting. Ripping is cutting along the length and with the grain of the workpiece. Crosscutting is cutting either

across the width or across the grain of the workpiece. Neither ripping nor crosscutting may be done safely freehand. Ripping requires the use of the rip fence, and crosscutting requires the miter gauge. **Never use a rip fence and miter gauge at the same time.**

⚠ WARNING

Before using the saw each and every time, check the following:

1. Blade is tight on the arbor.
2. Bevel angle lock knob is tight.
3. If ripping, fence lock handle is tight and fence is parallel to the blade.
4. Blade guard is in place and working properly.
5. Safety glasses are being worn.

The failure to adhere to these common safety rules, and those printed within this manual, can greatly increase the likelihood of injury.

RIPPING (FIG W, X)

⚠ WARNING

- Do not allow familiarity or frequent use of your table saw to cause careless mistakes. Remember that even a careless fraction of a second is enough to cause a severe injury.
- Keep both hands away from the blade and path of the blade.
- The workpiece must have a straight edge against the fence and must not be warped, twisted, or bowed.

⚠ DANGER

Never attempt to pull the workpiece backwards during a cutting operation. This will cause kickback and serious injury to the user can occur.

1. Remove the miter gauge. Secure the rip fence to the table at the desired rip measurement.
2. Raise the blade so it is about 1/8 in. higher than the top of the workpiece.
3. Place the workpiece flat on the table and against the fence. Keep the workpiece about 1 in. away from the blade.
4. Turn the saw ON and wait for the blade to come up to speed.
5. Slowly feed the workpiece into the blade by pushing forward only on the workpiece section (1) that will pass between the blade and the fence. (Fig. W)

▲ WARNING

AVOID KICKBACK by pushing forward that section of the workpiece that will pass between the blade and the fence. Use a push stick at all times.

Fig. W

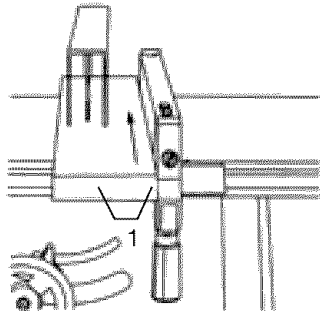

6. Keep your thumbs off the table top. When your hand reaches the front edge of the table (2), finish the cut with a push stick (3) (Fig. X). You can make a push stick using the pattern on page 28.
7. The push stick (3) should always be used during all ripping operations.
8. Continue pushing the workpiece with the push stick (3) until it passes the blade guard and clears the rear of the table.

▲ DANGER

Never attempt to pull the workpiece backwards during a cutting operation. This will cause kickback and serious injury to the user can occur. When the blade completely stops raise the anti-kickback pawls on each side of the splitter and slide the workpiece out.

Fig. X

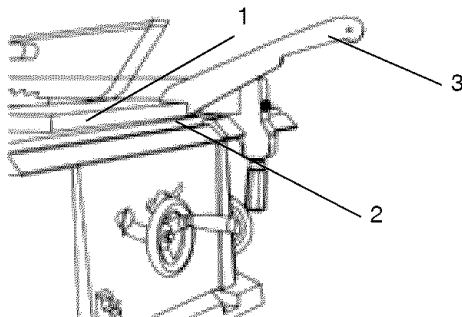

BEVEL RIPPING

This cut is the same as ripping except the blade bevel angle is set to an angle other than "0".

▲ WARNING

Cut only with the workpiece and the fence on the right side of the blade.

▲ DANGER

Never attempt to pull the workpiece backwards during a cutting operation. This will cause kickback and serious injury to the user can occur.

RIPPING SMALL PIECES

▲ WARNING

Avoid injury from the blade contact. Never make through-saw cuts narrower than 3/4 in. wide.

1. It is unsafe to rip small pieces. Instead, rip a larger piece to obtain the size of the desired piece.
2. When a small width is to be ripped, your hand cannot be safely put between the blade and the rip fence, therefore, use one or more push sticks to pass the workpiece completely through and past the blade.

CROSSCUTTING 90° MITER ANGLE (FIG. Y)

▲ WARNING

To prevent serious injury:

- **Do not allow familiarity or frequent use of your table saw to cause careless mistakes. Remember that even a careless fraction of a second is enough to cause a severe injury.**
- **Keep both hands away from the blade and the path of the blade.**
- **Never attempt to pull the workpiece backwards during a cutting operation. This will cause kickback and serious injury to the user can occur.**

1. Remove the rip fence and place the miter gauge a miter gauge groove on the table.
2. Adjust the blade height so it is 1/8 in. higher than the top of the workpiece.
3. Hold the workpiece firmly against the miter gauge with the blade path in line with the desired cut location. Move the workpiece to one inch distance from the blade.
4. Start the saw and wait for the blade (1) to come up to full speed. Never stand directly in line of the saw blade path, always stand to the side of the blade that you are cutting on.
5. Keep the workpiece (2) against the face of the miter gauge (3) and flat against the table. Then slowly push the workpiece through the blade.
6. Do not try to pull the workpiece back with the blade turning. Turn the switch OFF, and carefully slide the workpiece out when the blade is completely stopped.

▲ WARNING

Always position the larger surface of the workpiece on the table when crosscutting and/or bevel crosscutting to avoid instability.

Fig. Y

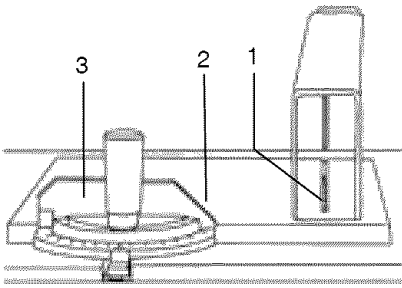

BEVEL CROSSCUTTING (FIG. AA)
0°~45° BLADE BEVEL & 90° MITER ANGLE

This cutting operation is the same as crosscutting except the blade is at a bevel angle other than 0°.

⚠ WARNING

Always work to the right side of the blade during this type of cut. The miter gauge must be in the right side groove because the bevel angle may cause the blade guard to interfere with the cut if used on the left side groove.

1. Adjust the blade (1) to the desired angle, and tighten the blade bevel lock knob.
2. Tighten miter lock handle (2) at 90°.
3. Hold workpiece (3) firmly against the face of the miter gauge throughout the cutting operation.

Fig. AA

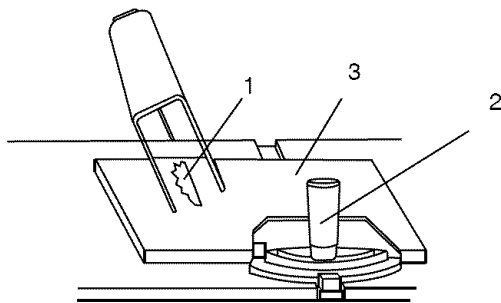

COMPOUND MITER CROSSCUTTING (FIG. BB)
0°~45° BLADE BEVEL & 0°~45° MITER ANGLE

This sawing operation is combining a miter angle with a bevel angle.

⚠ WARNING

Always work to the right side of the blade during this type of cut. The miter gauge must be in the right side groove because the bevel angle may cause the blade guard to interfere with the cut if used on the left side groove.

1. Set the miter gauge (3) to the desired angle.
2. Place the miter gauge in the right side groove of the table.
3. Set the blade (1) bevel to the desired bevel angle and tighten the blade bevel lock knob.
4. Hold workpiece (2) firmly against the face of the miter gauge throughout the cutting operation.

Fig. BB

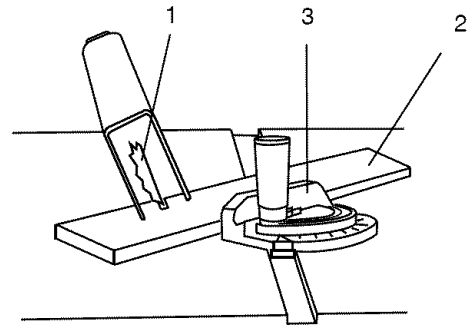

MITERING (FIG. CC) 0°~45° MITER ANGLE

This sawing operation is the same as crosscutting except the miter gauge is locked at an angle other than 90°.

1. Set the blade (1) to 0° bevel angle and tighten the blade bevel lock knob.
2. Set the miter gauge (3) at the desired miter angle and lock in position by tightening the miter gauge locking handle.
3. Hold the workpiece (2) firmly against the face of the miter gauge throughout the cutting operation.

Fig. CC

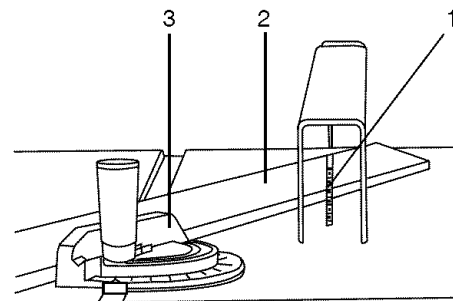

USING WOOD FACING ON THE RIP FENCE (FIG. DD)

When performing some special cutting operations, You can add a wood facing (1) to either side of the rip fence (2).

1. Use a smooth straight 3/4 in. thick wood board (1) that is as long as the rip fence.
2. Attach the wood facing to the fence with wood screws (3) through the holes in the fence. A wood fence should be used when ripping material such as thin paneling to prevent the material from catching between the bottom of the fence and the table.

Fig. DD

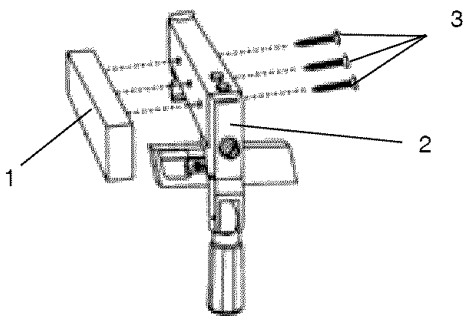

⚠ WARNING

ABRASIVE AND METAL CUTTING BLADES MUST NOT BE USED WITH THIS SAW

This saw was not made to cut metals or masonry materials. Doing so may result in injury. It will also void the warranty.

⚠ WARNING

ALL BLADES MUST:

1. Be rated at 5000 RPM or higher.
2. Have a 5/8 in. arbor hole.
3. Be no larger in diameter than 10 in.

Smaller diameter blades may be used. While this will result in a reduced depth of cut, the output of the motor will be increased.

DADO CUTS (FIG. EE)

⚠ WARNING

- a. **Only Stackable dado blades can be used on this saw.**
 - b. **DO NOT use Adjustable or Wobble type dadoes.**
 - c. **Maximum dado cut width is 1/2 in.**
1. A dado table insert must be purchased separately for this saw to accept a dado blade. Remove saw blade and blade guard for dado cuts **ONLY**. Reinstall and realign blade guard for all through sawing operations. Install a dado not exceeding 6 in. in diameter and 1/2 in. in width
 2. Install the dado table insert making sure the rear of the insert is flush with the table. A rubber adjusting spacer is provided under the rear of the insert for this purpose.
 3. Instruction for operating the dado is packed with the separately purchased dado set.
 4. The arbor (1) on this saw restricts the maximum width of the cut to 1/2 in.
 5. It is not necessary to install the outside flange (2) before threading on the arbor nut (3) for maximum 1/2 in. dado cuts. Make sure that the arbor nut (3) is tight, and that at least one thread of the arbor sticks out past the nut.
 6. Use only the correct number of round outside blades and inside chippers as shown in the dado set's instruction manual. Blade/chippers must not exceed 1/2 in. total in width.
 7. Check saw to ensure that the dado will not strike the housing, insert, or motor when in operation.

⚠ WARNING

For your own safety, always replace the blade, blade guard assembly, and blade insert when you are finished with the dado operation. You must also realign the blade guard assembly.

Fig. EE

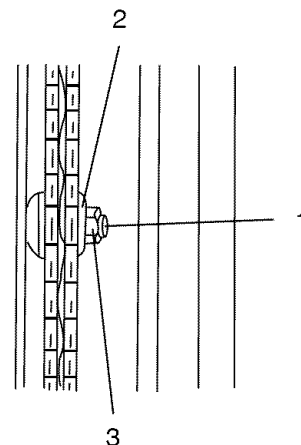

MAINTENANCE

GENERAL MAINTENANCE

⚠ WARNING

For your own safety, turn the switch OFF and remove the switch key. Remove the plug from the power source outlet before maintaining or lubricating your saw.

1. Clean out all sawdust that has accumulated inside the saw cabinet and the motor.
2. Polish the saw table with an automotive wax to keep it clean and to make it easier to slide the workpiece.
3. Clean cutting blades with pitch and gum remover.
4. A worn, cut, or damaged power cord should be replaced immediately.

⚠ WARNING

All electrical or mechanical repairs should be attempted only by a trained repair technician. Contact the nearest Sears Service Center for service. Use only identical replacement parts. Any other parts may create a hazard.

5. Use liquid dish washing detergent and water to clean all plastic parts. **NOTE:** Certain cleaning chemicals can damage plastic parts.
6. Avoid use of the following cleaning chemicals or solvents; ammonia and household detergents containing ammonia.

BLADE RAISING AND TILTING MECHANISM

After each five full hours of operation, the blade raising mechanism and tilting mechanism should be checked for looseness, binding, or other abnormalities. With the saw disconnected from the power source, turn the saw upside down and alternately pull upward and downward on the motor unit. Observe any movement of the motor mounting mechanism. Looseness or play in the blade raising screw (1) (Fig. FF) should be adjusted as follows:

1. Using a 14 mm wrench, loosen the check-nut (2).
2. Adjust nut (3) until it is finger-tight against the bracket (4), then back off the nut (3) 1/6 turn.
3. Tighten nut (2) with the wrench, while holding nut (3) in place. Maximum allowable play of screw rod (1) is 4 mm.

Fig. FF

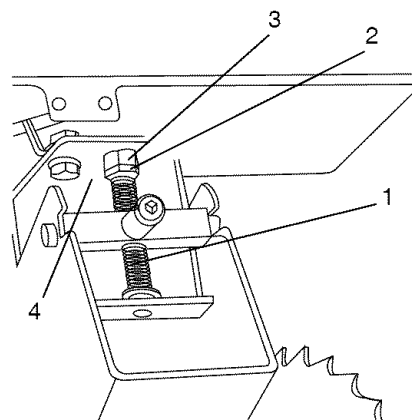

You can place a small amount of dry lubricant on bevel angle adjustment rod also. This rod (1) must be kept clean and free of sawdust, gum, pitch, and other contaminants for smooth operation.

If excessive looseness is observed in any parts of the blade raising mechanism or tilting mechanism, take the complete unit to a Sears Service Center.

LUBRICATION

All motor bearings are permanently lubricated at the factory and require no additional lubrication. On all mechanical parts of your table saw where a pivot or threaded rod are present, lubricate using graphite or silicone. These dry lubricants will not hold sawdust as would oil or grease.

TROUBLESHOOTING GUIDE

WARNING

To avoid injury from an accidental start, turn the switch OFF and always remove the plug from the power source before making any adjustments.

- Consult your local Sears Service Center if for any reason the motor will not run.

SYMPTOM	POSSIBLE CAUSES	CORRECTIVE ACTION
Saw will not start.	<ol style="list-style-type: none"> 1. Saw not plugged in. 2. Fuse blown or circuit breaker tripped. 3. Cord damaged. 4. Debris in on/off switch 	<ol style="list-style-type: none"> 1. Plug in saw. 2. Replace fuse or reset circuit breaker. 3. Replace power cord. 4. Remove switch from saw and separate in half. Clean any debris accumulated within.
Does not make accurate 45° and 90° rip cuts.	<ol style="list-style-type: none"> 1. Positive stop not adjusted correctly. 2. Tilt angle pointer not set accurately. 	<ol style="list-style-type: none"> 1. Check blade with square and adjust positive stop. 2. Check blade with square and adjust to zero.
Material pinched blade when ripping.	<ol style="list-style-type: none"> 1. Rip fence not aligned with blade. 2. Warped wood, edge against fence is not straight. 	<ol style="list-style-type: none"> 1. Check and align rip fence and blade. 2. Select another piece of wood.
Material binds on splitter.	<ol style="list-style-type: none"> 1. Splitter not aligned correctly with blade. 	<ol style="list-style-type: none"> 1. Check and align splitter with blade.
Saw makes unsatisfactory cuts.	<ol style="list-style-type: none"> 1. Dull blade. 2. Blade mounted backwards. 3. Gum or pitch on blade. 4. Incorrect blade for work being done. 5. Gum or pitch on blade causing erratic feed. 	<ol style="list-style-type: none"> 1. Replace blade. 2. Turn the blade around. 3. Remove blade and clean with turpentine and coarse steel wool. 4. Change the blade. 5. Clean table with turpentine and steel wool.
Material kicked back from blade.	<ol style="list-style-type: none"> 1. Rip fence out of adjustment. 2. Splitter not aligned with blade. 3. Feeding stock without rip fence. 4. Splitter not in place. 5. Dull blade. 6. The operator letting go of material before it is past saw blade. 7. Miter angle lock knob is not tight. 	<ol style="list-style-type: none"> 1. Align rip fence with miter gauge slot. 2. Align splitter with blade. 3. Install and use rip fence. 4. Install and use splitter. (with guard) 5. Replace blade. 6. Push material all the way past saw blade before releasing work. 7. Tighten knob.
Blade does not raise or tilt freely.	<ol style="list-style-type: none"> 1. Sawdust and dirt in elevation/tilting mechanisms. 	<ol style="list-style-type: none"> 1. Brush or blow out loose dust and dirt.
Blade does not come up to speed.	<ol style="list-style-type: none"> 1. Extension cord too light or too long. 2. Low house voltage. 	<ol style="list-style-type: none"> 1. Replace with adequate size cord. 2. Contact your electric company.
Machine vibrates excessively.	<ol style="list-style-type: none"> 1. Saw not mounted securely to workbench. 2. Bench on uneven floor. 3. Damaged saw blade. 	<ol style="list-style-type: none"> 1. Tighten all mounting hardware. 2. Reposition on flat level surface. 3. Replace blade.
Does not make accurate 45° and 90° crosscuts.	<ol style="list-style-type: none"> 1. Miter gauge out of adjustment. 	<ol style="list-style-type: none"> 1. Adjust miter gauge.

PARTS LIST

10 IN. TABLE SAW PARTS LIST

MODEL NO. 137.218020

WARNING

When servicing use only CRAFTSMAN replacement parts. Use of any other parts may create a HAZARD or cause product damage. Any attempt to repair or replace electrical parts on this Table Saw may create a HAZARD unless repair is done by a qualified service technician. Repair service is available at your nearest Sears Service Center.

I.D. NO	Description	Size	Qty	I.D. NO	Description	Size	Qty
09JK	WRENCH		1	OJYN	HEX. SOC. COUNTERSUNK HD. SCREW	M6*1.0-25	6
0AV8	BODY SHELL		1	OKOZ	HEX. HD. SCREW AND WASHER	M8*1.25-16	4
0AW8	SEGMENT GEAR		1	OK16	HEX. HD. SCREW AND WASHER	M8*1.25-16	1
0B1M	WHEEL		1	OK25	HEX. SOC. HD. CAP SCREW	M5*0.8-20	1
0B21	HEIGHT REGULATING BOLT		1	OK3G	CR. RE. PAN HD. SCREW & WASHER	M5*0.8-12	1
0B23	SADDLE		1	OK3R	CR. RE. PAN HD. SCREW & WASHER	M5*0.8-12	3
0B24	SPRING		1	OK5P	CR. RE. COUNT HD. SCREW	M6*1.0-50	4
0B25	POINTER BRACKET		1	OK8C	CR. RE. COUNT HD. TAPPING SCREW	M4*18-10	8
0B2C	SWITCH BOX		1	OK91	CR. RE. TRUSS HD. TAPPING SCREW	M4*16-12	4
0B3H	INSERT	#23	1	OKA4	CR.RE. PAN HD. TAPPING SCREW	M4*16-16	2
0B3R	WRENCH		1	OKCX	CR. RE. PAN HD PLAIN WASHER TAPPING SCREW	M5*0.8-10	2
0B3W	RETAINING CLIP		1	OKEK	CR. RE. PAN HD. SCREW	M6*1.0-30	1
0B48	WARNING LABEL		1	OKEM	CR. RE. PAN HD. SCREW	M6*1.0-40	1
0B61	LINK		1	OKF7	CR. RE. PAN HD. SCREW	M4*0.7-12	2
0B6R	CLAMP HANDLE		1	OKJ4	CAP HD. SQ. NECK BOLT	M6*1.0-35	1
0B6S	CLAMP HANDLE		1	OKJ5	CAP HD. SQ. NECK BOLT	M6*1.0-80	1
0B84	WASHER	D=φ18	1	OKKW	CR. RE. PAN HD. ROUND NECK SCREW	M6*1.0-16	1
0B99	SPACER		1	OKMR	HEX. NUT	M5*0.8 T=4	1
0B9C	PLUNGER HOUSING		1	OKMS	HEX. NUT	M6*1.0 T=5	1
0B9G	ANGLE ROD		1	OKMV	HEX. NUT	M10*1.5 T=8	1
0B9M	STRAP		6	OKMW	HEX. NUT	M10*1.5 T=4	1
0B9W	BRACKET		1	OKMY	HEX. NUT	M8*1.25 T=6.5	2
0B9Z	COMPRESSION SPRING		1	OKQJ	CROWN NUT	M8*1.25 T=12.5	1
0BA1	COMPRESSION SPRING		1	OKRQ	SERRATED TOOTHED HEXAGON FLANGE NUT	M6*1.0 T=6	6
0BA4	SPACER		1	OKRX	HEXAGON NUT AND FLAT WASHER	M6*1.0	5
0BAC	SET NUT		1	OKSW	STRAIN RELIEF		1
0BAE	ARBOR COLLAR		1	OKTA	STRAIN RELIEF		2
0BAJ	BLADE		1	OL65	POWER CABLE ASS'Y		1
0BPA	LOCK KNOB		1	OLSL	CIRCUIT BREAKER SWITCH		1
0G1U	DUST SHIELD		4	OLWC	ROCKER SWITCH		1
0J3P	HEX. WRENCH		1	0QQ0	CLAMP-CORD		1
0J4E	FLAT WASHER	φ6*13-1	1	OSGC	HANDLE BAR		1
0J4F	FLAT WASHER	φ8*16-2.5	1	OWPL	SWITCH KEY		1
0J4H	FLAT WASHER	φ10*30-0.2	2	20WQ	HEX. HD. BOLT	M6*1.0-50	1
0J70	FLAT WASHER	1/4*3/4-7/64	1	21BN	BRACKET GROUP ASS'Y		1
0J72	FLAT WASHER	1/4*5/8-1/16	1	27QV	DEFLECTOR		1
0J76	FLAT WASHER		5	28KD	TILT POINTER	#23	1
0J7F	FLAT WASHER	5/16*7/8-5/64	1	2919	FLAT WASHER	φ10*17-2 6	1
0J7K	FLAT WASHER	3/8*29/32-5/64	1	29PD	WARNING LABEL		1
0J7V	FLAT WASHER	5/8*1 3/8-5/64	1	29R2	WARNING LABEL		1
0J8D	FLAT WASHER	3/8*3/4-5/64	2	2BJM	MITER GAUGE ASS'Y		1
0J8K	FLATE WASHER	1/4*3/4-1/16	1	2BUF	RIP FENCE ASS'Y		1
0J95	SPRING WASHER	φ6	1	2ERN	BLADE GUARD ASS'Y		1
0J9H	SPRING WASHER	φ1/4	6	2EUC	TABLE	#53	1
0JAA	WASHER	φ8	1	2F2F	MOTOR ASS'Y		1
0JAE	EXTERNAL TOOTH LOCK WASHER	φ4	2	2FDU	INSTRUCTION MANUAL		1
0JC9	SPRING PIN		1	2FLL	LABEL		1
0JE7	C-RING		1	2FRJ	SCALE		1
0JXL	HEX. SOC. SET SCREW	M10*1.5-12	1				

10 IN. TABLE SAW SCHEMATIC

MODEL NO. 137.218020

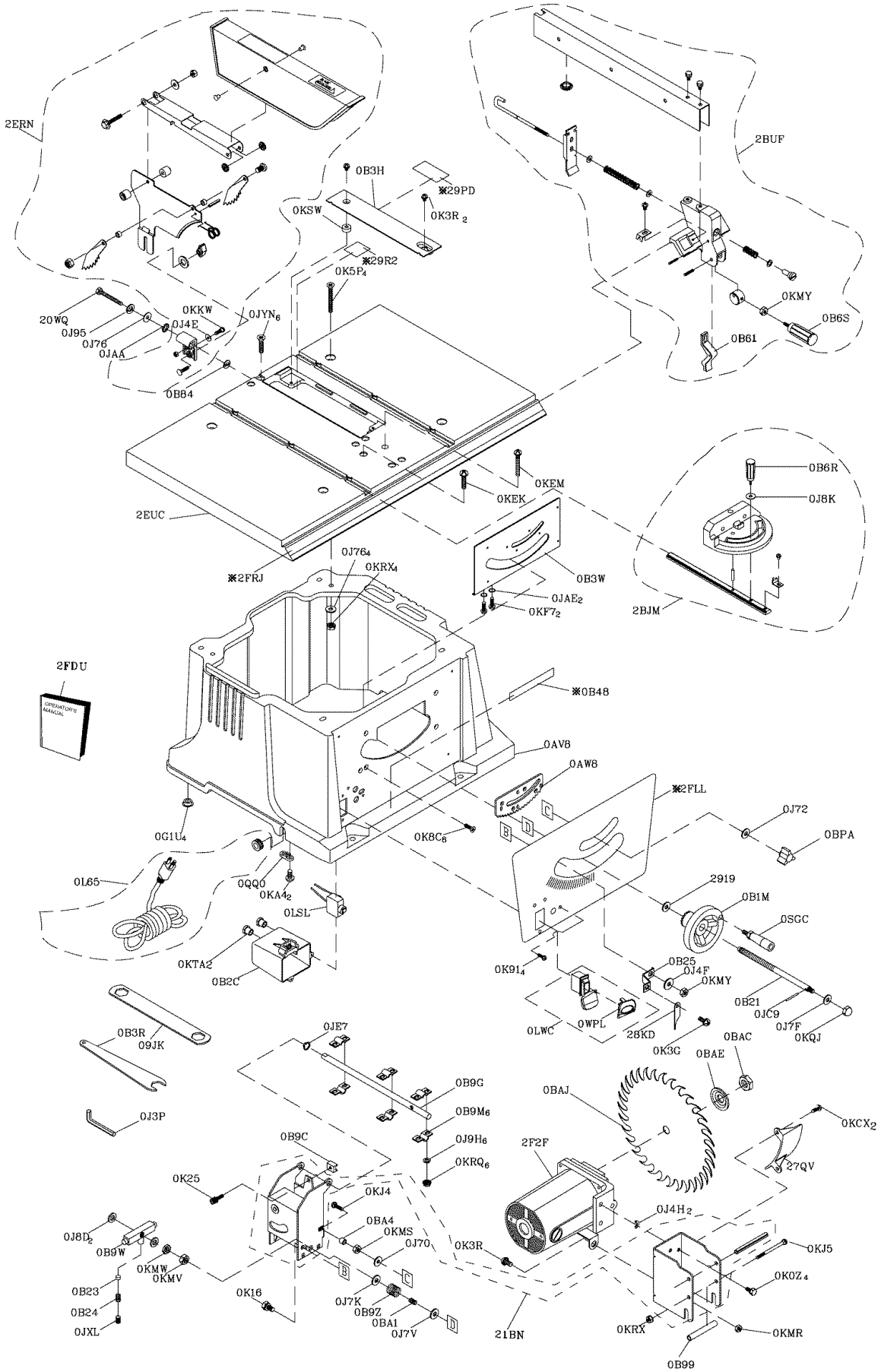

STAND

I.D. No.	Description	Size	Qty
093B	FOOT PAD		4
0JPQ	HEX. HD. BOLT	M8*1.25-35	4
0KRR	SERRATED TOOTHED HEXAGON FLANGE NUT	M8*1.25 T=7.5	20
29RE	BOTTOM SUPPORT BRACKET	#06	2
29RF	BOTTOM SUPPORT BRACKET	#06	2
29RS	UPPER SUPPORT	#06	2
29RT	UPPER SUPPORT	#06	2
29RU	BRACKET	#06	4
2FD4	HARDWARE BAG ASS'Y		1
2A10	CAP HD. SQ. NECK BOLT	M8*0.25-12	16

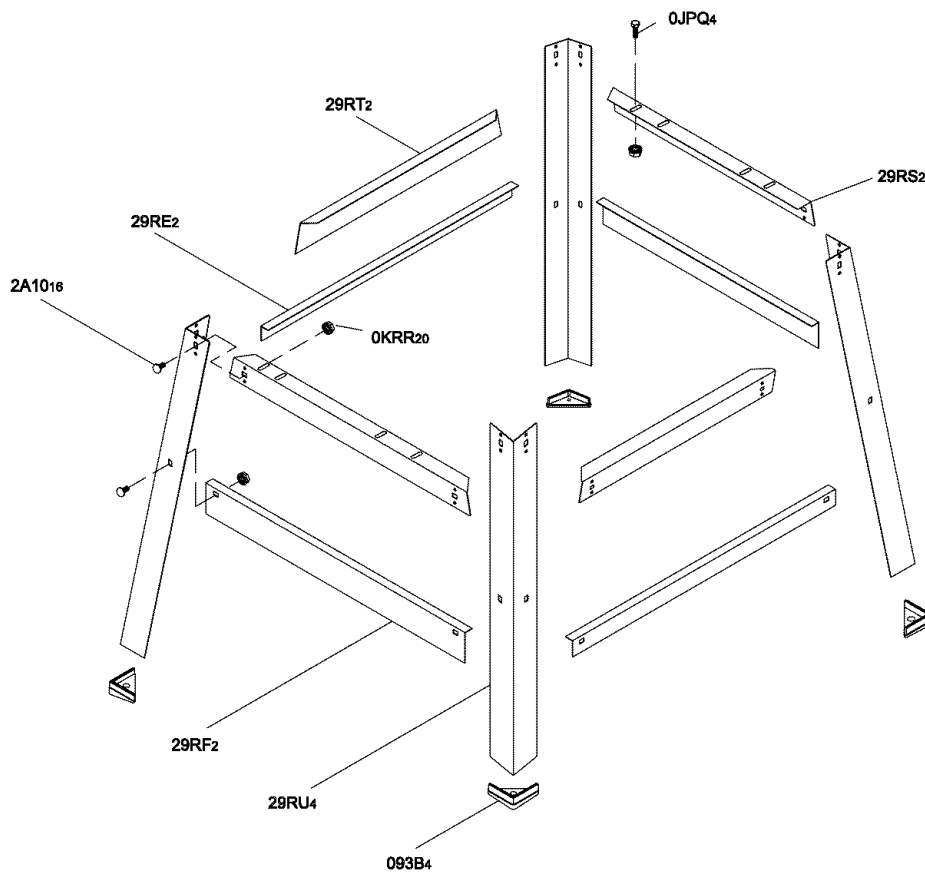

MOTOR

I.D. No.	Description	Size	Qty	I.D. No.	Description	Size	Qty
0HV5	BALL BEARING	6204LLU	1	0QFG	BRUSH HOLDER ASS'Y		2
0HVU	BALL BEARING	6200ZZ	1	0R1S	BEARING BUSHING		1
0JX3	HEX. SOC. SET SCREW	M5*0.8-8	2	10ZQ	NEEDLE BEARING		1
0K3A	CR.RE. PAN HD. SCREW & WASHER	M5*0.8-30	4	2F2S	BRACKET		1
0K71	CR. RE. TRUSS HD. SCREW	M5*0.8-8	2	2F2T	FIELD ASS'Y		1
0KCN	CR.RE. PAN HEAD TAPPING & WASHER SCREW	M5*12-50	2	2F2U	ARMATURE ASS'Y		1
0KSB	STRAIN RELIEF		1	2F59	CUTTER SHAFT ASS'Y		1
0LMH	LOCKING CABLE TIE		4	2F5R	MOTOR COVER		1
0QEK	MOTOR NAMEPLATE		1	2F5Z	FLOW GUIDE		1
0QFE	BRUSH COVER		2	2F8X	RETAINING CLIP		1
0QFF	CARBON BRUSH ASS'Y		2				

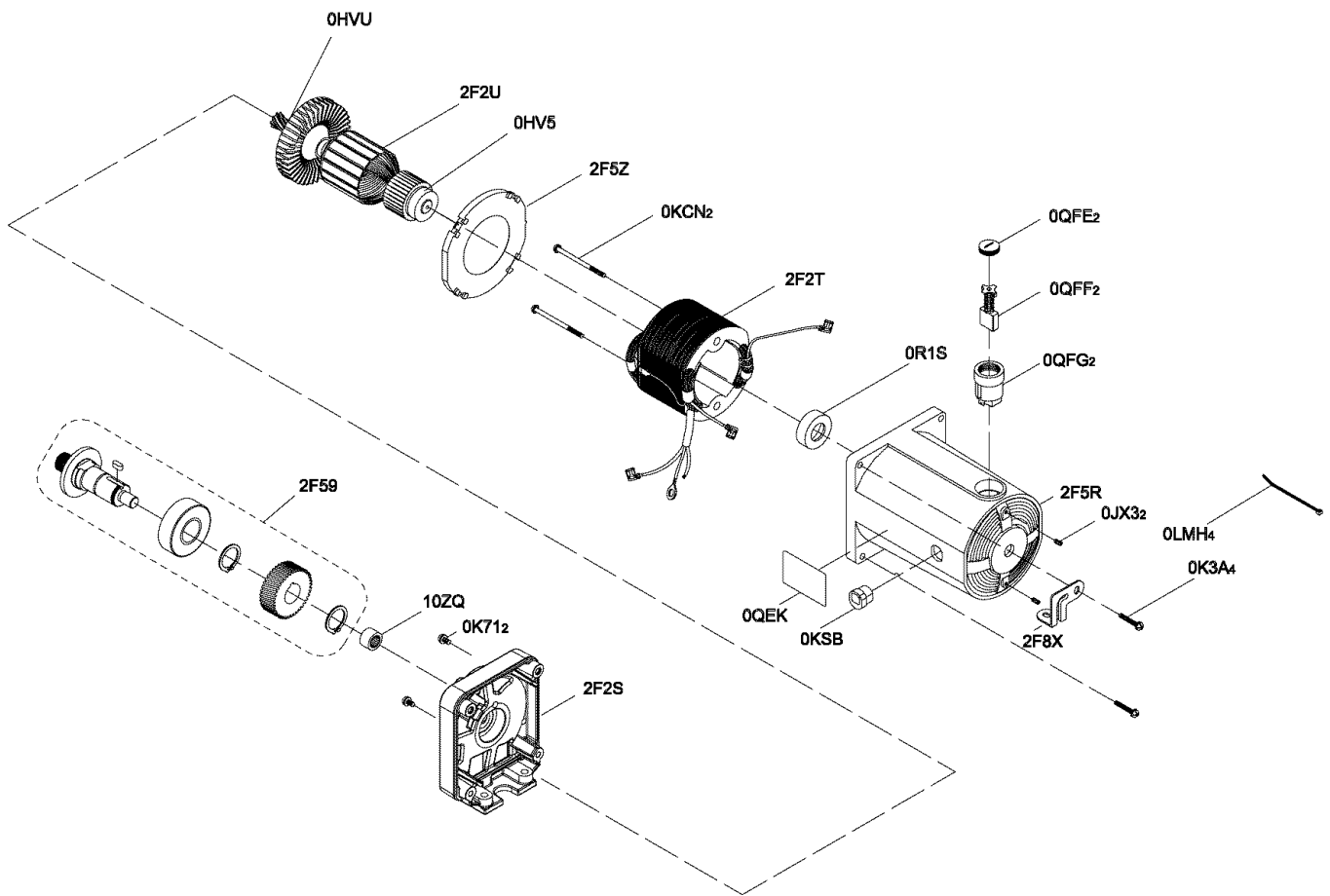

PUSH STICK CONSTRUCTION

- This is a full-size drawing (actual size)
- Use good quality plywood or solid wood
- Use 1/2 in. or 3/4 in. material
- Push stick MUST be thinner than the width of material being cut

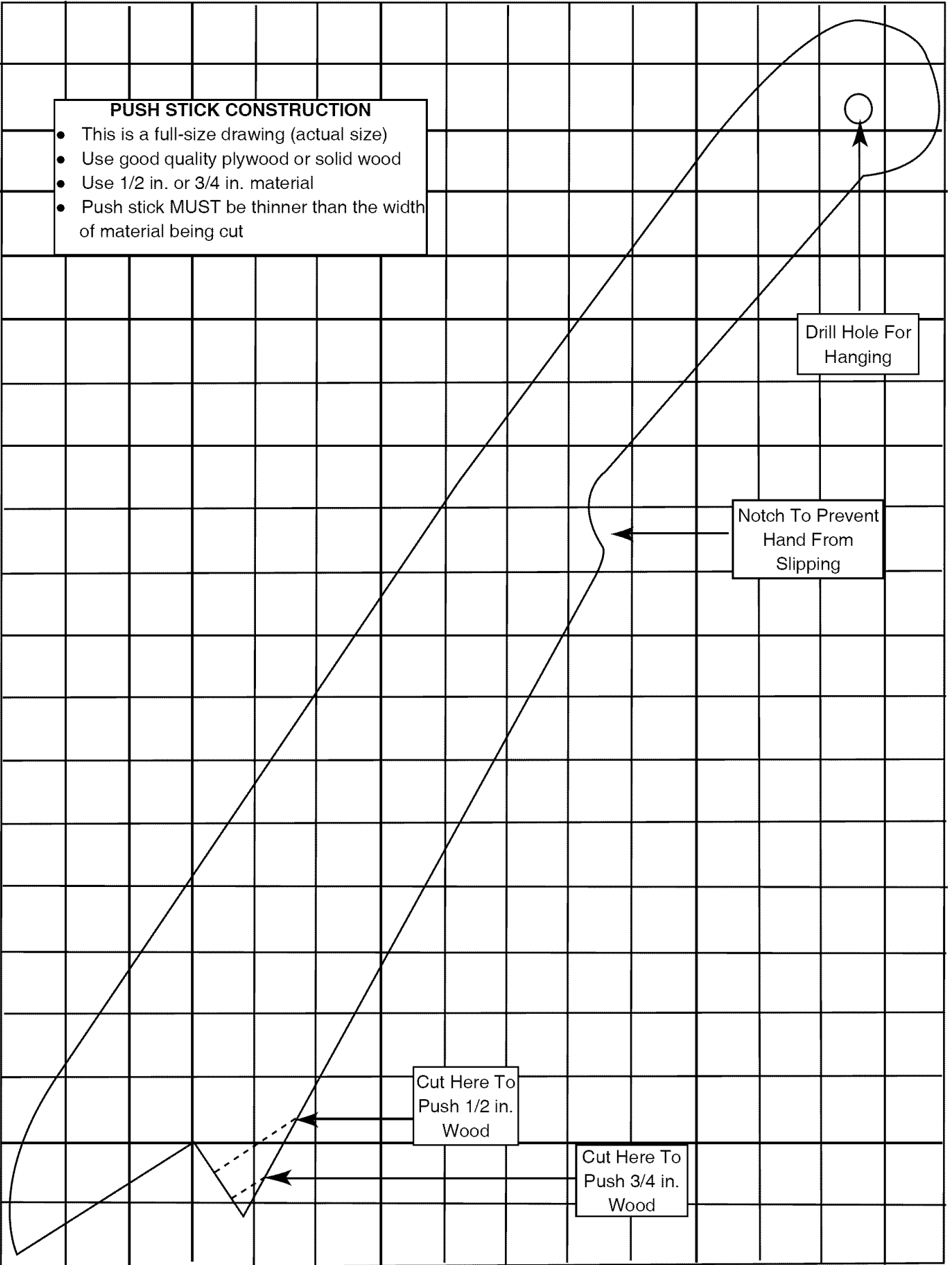

Drill Hole For Hanging

Notch To Prevent Hand From Slipping

Cut Here To Push 1/2 in. Wood

Cut Here To Push 3/4 in. Wood

Get it fixed, at your home or ours!

Your Home

For repair – **in your home** – of **all** major brand appliances, lawn and garden equipment, or heating and cooling systems, **no matter who made it, no matter who sold it!**

For the replacement parts, accessories and owner's manuals that you need to do-it-yourself.

For Sears professional installation of home appliances and items like garage door openers and water heaters.

1-800-4-MY-HOME® (1-800-469-4663)

Call anytime, day or night (U.S.A. and Canada)

www.sears.com www.sears.ca

Our Home

For repair of carry-in items like vacuums, lawn equipment, and electronics, call or go on-line for the location of your nearest

Sears Parts & Repair Center.

1-800-488-1222

Call anytime, day or night (U.S.A. only)

www.sears.com

To purchase a protection agreement (U.S.A.) or maintenance agreement (Canada) on a product serviced by Sears:

1-800-827-6655 (U.S.A.)

1-800-361-6665 (Canada)

Para pedir servicio de reparación a domicilio, y para ordenar piezas:

1-888-SU-HOGAR®

(1-888-784-6427)

Au Canada pour service en français:

1-800-LE-FOYER^{MC}

(1-800-533-6937)

www.sears.ca

The Sears logo is displayed in a large, stylized font with a horizontal line underneath it.

Free Manuals Download Website

<http://myh66.com>

<http://usermanuals.us>

<http://www.somanuals.com>

<http://www.4manuals.cc>

<http://www.manual-lib.com>

<http://www.404manual.com>

<http://www.luxmanual.com>

<http://aubethermostatmanual.com>

Golf course search by state

<http://golfingnear.com>

Email search by domain

<http://emailbydomain.com>

Auto manuals search

<http://auto.somanuals.com>

TV manuals search

<http://tv.somanuals.com>