

# Operator's Manual

# CRAFTSMAN®

## 10 in. COMPOUND MITER SAW Double Insulated

Model No.  
315.212040

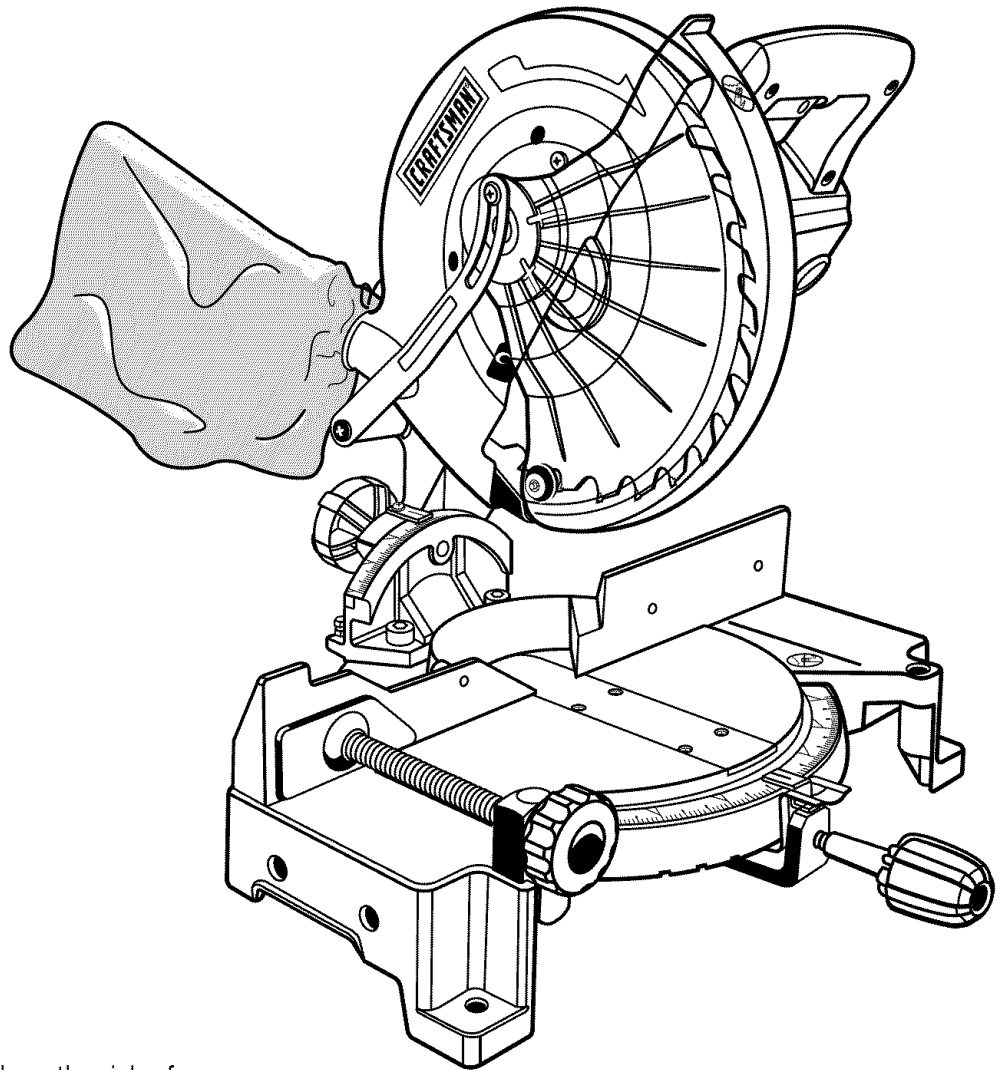

**WARNING:** To reduce the risk of injury, the user must read and understand the operator's manual before using this product.

Customer Help Line: 1-800-932-3188

Sears, Roebuck and Co., Hoffman Estates, IL 60179 USA  
Visit the Craftsman web page: [www.sears.com/craftsman](http://www.sears.com/craftsman)

983000-471  
2-04

Save this manual for future reference



# TABLE OF CONTENTS

■ Warranty and Introduction.....	2
■ General Safety Rules.....	3-4
■ Specific Safety Rules.....	4-5
■ Symbols.....	6-7
■ Electrical.....	8
■ Glossary of Terms for Woodworking.....	9
■ Features.....	10-12
■ Unpacking and Tools Needed.....	13
■ Loose Parts.....	14
■ Assembly.....	15-21
■ Operation.....	21-28
■ Adjustments.....	29-30
■ Maintenance.....	31
■ Exploded View and Repair Parts List.....	32-39
■ Parts Ordering/Service.....	40

## WARRANTY

### FULL ONE YEAR WARRANTY

If this product fails due to a defect in material or workmanship within one year from the date of purchase, Sears will repair it free of charge.

Contact a Sears Service Center for repair.

If this product is used for commercial or rental purposes, this warranty applies only for 90 days from the date of purchase.

This warranty gives you specific legal rights, and you may also have other rights which vary from state to state.

**Sears, Roebuck and Co., Dept. 817WA, Hoffman Estates, IL 60179**

## INTRODUCTION

Your saw has many features for making cutting operations more pleasant and enjoyable. Safety, performance and dependability have been given top priority in the design of this saw making it easy to maintain and operate.

# GENERAL SAFETY RULES

 **WARNING: Read and understand all instructions.** Failure to follow all instructions listed below, may result in electric shock, fire and/or serious personal injury.

## READ ALL INSTRUCTIONS

- **KNOW YOUR POWER TOOL.** Read the operator's manual carefully. Learn the saw's applications and limitations as well as the specific potential hazards related to this tool.
- **GUARD AGAINST ELECTRICAL SHOCK BY PREVENTING BODY CONTACT WITH GROUNDED SURFACES.** For example, pipes, radiators, ranges, refrigerator enclosures.
- **KEEP GUARDS IN PLACE** and in good working order. Never operate the tool with any guard or cover removed. Make sure all guards are operating properly before each use.
- **REMOVE ADJUSTING KEYS AND WRENCHES.** Form habit of checking to see that keys and adjusting wrenches are removed from tool before turning it on.
- **KEEP WORK AREA CLEAN.** Cluttered areas and benches invite accidents. **DO NOT** leave tools or pieces of wood on the saw while it is in operation.
- **AVOID DANGEROUS ENVIRONMENTS.** Don't use power tools in damp or wet locations or expose to rain. Keep the work area well lit.
- **KEEP CHILDREN AND VISITORS AWAY.** All visitors should wear safety glasses and be kept a safe distance from work area. Do not let visitors contact tool or extension cord while operating.
- **MAKE WORKSHOP CHILDPROOF** with padlocks and master switches, or by removing starter keys.
- **DON'T FORCE TOOL.** It will do the job better and safer at the feed rate for which it was designed.
- **USE RIGHT TOOL.** Don't force the tool or attachment to do a job it was not designed for. Don't use it for a purpose not intended.
- **MAKE SURE YOUR EXTENSION CORD IS IN GOOD CONDITION.** When using an extension cord, be sure to use one heavy enough to carry the current your product will draw. An undersized cord will cause a drop in line voltage resulting in loss of power and overheating. A wire gage size (A.W.G.) of at least **14** is recommended for an extension cord 25 feet or less in length. If in doubt, use the next heavier gage. The smaller the gage number, the heavier the cord.
- **DRESS PROPERLY.** Do not wear loose clothing, gloves, neckties, or jewelry. They can get caught and draw you into moving parts. Rubber gloves and nonskid footwear are recommended when working outdoors. Also wear protective hair covering to contain long hair.
- **ALWAYS WEAR SAFETY GLASSES WITH SIDE SHIELDS.** Everyday eyeglasses have only impact-resistant lenses, they are **NOT** safety glasses.
- **SECURE WORK.** Use clamps or a vise to hold work when practical. It's safer than using your hand and frees both hands to operate tool.
- **DON'T OVERREACH.** Keep proper footing and balance at all times.
- **MAINTAIN TOOLS WITH CARE.** Keep tools sharp and clean for better and safer performance. Follow instructions for lubricating and changing accessories.
- **DISCONNECT TOOLS.** When not in use, before servicing, or when changing attachments, blades, bits, cutters, etc., all tools should be disconnected.
- **AVOID ACCIDENTAL STARTING.** Be sure switch is off when plugging in any tool.
- **USE RECOMMENDED ACCESSORIES.** The use of improper accessories may risk injury.
- **NEVER STAND ON TOOL.** Serious injury could occur if the tool is tipped or if the cutting tool is unintentionally contacted.
- **CHECK DAMAGED PARTS.** Before further use of the tool, a guard or other part that is damaged should be carefully checked to determine that it will operate properly and perform its intended function. Check for alignment of moving parts, binding of moving parts, breakage of parts, mounting and any other conditions that may affect its operation. A guard or other part that is damaged must be properly repaired or replaced by an authorized service center to avoid risk of personal injury.
- **USE THE RIGHT DIRECTION OF FEED.** Feed work into a blade or cutter against the direction of rotation of blade or cutter only.
- **NEVER LEAVE TOOL RUNNING UNATTENDED. TURN THE POWER OFF.** Don't leave tool until it comes to a complete stop.
- **PROTECT YOUR LUNGS.** Wear a face or dust mask if the cutting operation is dusty.
- **PROTECT YOUR HEARING.** Wear hearing protection during extended periods of operation.
- **DON'T ABUSE CORD.** Never yank cord to disconnect from receptacle. Keep cord from heat, oil, and sharp edges.
- **USE OUTDOOR EXTENSION CORDS.** When tool is used outdoors, use only extension cords with approved ground connection that are intended for use outdoors and so marked.
- **KEEP BLADES CLEAN, SHARP, AND WITH SUFFICIENT SET.** Sharp blades minimize stalling and kickback.
- **BLADE COASTS AFTER BEING TURNED OFF.**

# GENERAL SAFETY RULES

- **NEVER USE IN AN EXPLOSIVE ATMOSPHERE.** Normal sparking of the motor could ignite fumes.
- **INSPECT TOOL CORDS PERIODICALLY.** If damaged, have repaired by a qualified service technician at an authorized service facility. The conductor with insulation having an outer surface that is green with or without yellow stripes is the equipment-grounding conductor. If repair or replacement of the electric cord or plug is necessary, do not connect the equipment-grounding conductor to a live terminal. Repair or replace a damaged or worn cord immediately. Stay constantly aware of cord location and keep it well away from the rotating blade.
- **INSPECT EXTENSION CORDS PERIODICALLY** and replace if damaged.
- **KEEP TOOL DRY, CLEAN, AND FREE FROM OIL AND GREASE.** Always use a clean cloth when cleaning. Never use brake fluids, gasoline, petroleum-based products, or any solvents to clean tool.
- **STAY ALERT AND EXERCISE CONTROL.** Watch what you are doing and use common sense. Do not operate tool when you are tired. Do not rush.
- **DO NOT USE TOOL IF SWITCH DOES NOT TURN IT ON AND OFF.** Have defective switches replaced by an authorized service center.
- **USE ONLY CORRECT BLADES.** Do not use blades with incorrect size holes. Never use blade washers or blade bolts that are defective or incorrect. The maximum blade capacity of your saw is 10 in. (254 mm).
- **BEFORE MAKING A CUT, BE SURE ALL ADJUSTMENTS ARE SECURE.**
- **AVOID CUTTING NAILS.** Inspect for and remove all nails from lumber before cutting.
- **NEVER TOUCH BLADE** or other moving parts during use.
- **NEVER START A TOOL WHEN ANY ROTATING COMPONENT IS IN CONTACT WITH THE WORKPIECE.**
- **DO NOT OPERATE A TOOL WHILE UNDER THE INFLUENCE OF DRUGS, ALCOHOL, OR ANY MEDICATION.**
- **POLARIZED PLUGS.** To reduce the risk of electric shock, this tool has a polarized plug (one blade is wider than the other). This plug will fit in a polarized outlet only one way. If the plug does not fit fully in the outlet, reverse the plug. If it still does not fit, contact a qualified electrician to install the proper outlet. Do not change the plug in any way.
- **WHEN SERVICING** use only identical replacement parts. Use of any other parts may create a hazard or cause product damage.
- **CHECK WITH A QUALIFIED ELECTRICIAN** or service personnel if the grounding instructions are not completely understood or if in doubt as to whether the tool is properly grounded.
- **USE ONLY RECOMMENDED ACCESSORIES** listed in this manual or addendums. Use of accessories that are not listed may cause the risk of personal injury. Instructions for safe use of accessories are included with the accessory.
- **DOUBLE CHECK ALL SETUPS.** Make sure blade is tight and not making contact with saw or workpiece before connecting to power supply.
- **MAKE SURE THE WORK AREA HAS AMPLE LIGHTING** to see the work and that no obstructions will interfere with safe operation **BEFORE** performing any work using the table saw.

# SPECIFIC SAFETY RULES

- **FIRMLY CLAMP OR BOLT** your miter saw to a workbench or table at approximately hip height.
- **DO NOT REMOVE THE SAW'S BLADE GUARDS.** Never operate the saw with any guard or cover removed. Make sure all guards are operating properly before each use.
- **KEEP HANDS AWAY FROM CUTTING AREA.** Do not reach underneath work or in blade cutting path with your hands and fingers for any reason. Always turn the power off.
- **ALWAYS SUPPORT LONG WORKPIECES** while cutting to minimize risk of blade pinching and kickback. Saw may slip, walk or slide while cutting long or heavy boards.
- **ALWAYS USE A CLAMP** to secure the workpiece when possible.
- **BE SURE THE BLADE CLEARS THE WORKPIECE.** Never start the saw with the blade touching the workpiece. Allow motor to come up to full speed before starting cut.
- **MAKE SURE THE MITER TABLE AND SAW ARM (BEVEL FUNCTION) ARE LOCKED IN POSITION BEFORE OPERATING YOUR SAW.** Lock the miter table by securely tightening the miter lock handle. Lock the saw arm (bevel function) by securely tightening the bevel lock knob.
- **NEVER USE A LENGTH STOP ON THE FREE SCRAP END OF A CLAMPED WORKPIECE. NEVER** hold onto or bind the free scrap end of the workpiece in any operation. If a work clamp and length stop are used together, they must both be installed on the same side of the saw table to prevent the saw from catching the loose end and kicking up.

# SPECIFIC SAFETY RULES

- **NEVER** cut more than one piece at a time. **DO NOT STACK** more than one workpiece on the saw table at a time.
- **NEVER PERFORM ANY OPERATION FREEHAND.** Always place the workpiece to be cut on the miter table and position it firmly against the fence as a back-stop. Always use the fence.
- **NEVER** hand hold a workpiece that is too small to be clamped. Keep hands clear of the no hands zone.
- **NEVER** reach behind, under, or within three inches of the blade and its cutting path with your hands and fingers for any reason.
- **NEVER** reach to pick up a workpiece, a piece of scrap, or anything else that is in or near the cutting path of the blade.
- **AVOID AWKWARD OPERATIONS AND HAND POSITIONS** where a sudden slip could cause your hand to move into the blade. **ALWAYS** make sure you have good balance. **NEVER** operate your miter saw on the floor or in a crouched position.
- **NEVER** stand or have any part of your body in line with the path of the saw blade.
- **ALWAYS** release the power switch and allow the saw blade to stop rotating before raising it out of the workpiece.
- **DO NOT TURN THE MOTOR SWITCH ON AND OFF RAPIDLY.** This could cause the saw blade to loosen and could create a hazard. Should this ever occur, stand clear and allow the saw blade to come to a complete stop. Disconnect your saw from the power supply and securely retighten the blade bolt.
- **IF ANY PART OF THIS MITER SAW IS MISSING** or should break, bend, or fail in any way, or should any electrical component fail to perform properly, shut off the power switch, remove the miter saw plug from the power source and have damaged, missing, or failed parts replaced before resuming operation.
- **ALWAYS STAY ALERT!** Do not allow familiarity (gained from frequent use of your saw) to cause a careless mistake. **ALWAYS REMEMBER** that a careless fraction of a second is sufficient to inflict severe injury.
- **MAKE SURE THE WORK AREA HAS AMPLE LIGHTING** to see the work and that no obstructions will interfere with safe operation **BEFORE** performing any work using your saw.
- **ALWAYS TURN OFF THE SAW** before disconnecting it to avoid accidental starting when reconnecting to power supply. **NEVER** leave the saw unattended while connected to a power source.
- **NEVER** lift this tool by gripping the sliding miter fence.
- **SAVE THESE INSTRUCTIONS.** Refer to them frequently and use to instruct other users. If you loan someone this tool, loan them these instructions also.

---











 **WARNING:** Some dust created by power sanding, sawing, grinding, drilling, and other construction activities contains chemicals known to cause cancer, birth defects or other reproductive harm. Some examples of these chemicals are:

- lead from lead-based paints,
- crystalline silica from bricks and cement and other masonry products, and
- arsenic and chromium from chemically-treated lumber.

Your risk from these exposures varies, depending on how often you do this type of work. To reduce your exposure to these chemicals: work in a well ventilated area, and work with approved safety equipment, such as those dust masks that are specially designed to filter out microscopic particles.



# SYMBOLS

Some of the following symbols may be used on this tool. Please study them and learn their meaning. Proper interpretation of these symbols will allow you to operate the tool better and safer.

SYMBOL	NAME	DESIGNATION/EXPLANATION
V	Volts	Voltage
A	Amperes	Current
Hz	Hertz	Frequency (cycles per second)
W	Watt	Power
min	Minutes	Time
~	Alternating Current	Type of current
—	Direct Current	Type or a characteristic of current
$n_0$	No Load Speed	Rotational speed, at no load
	Class II Construction	Double-insulated construction
.../min	Per Minute	Revolutions, strokes, surface speed, orbits etc., per minute
	Wet Conditions Alert	Do not expose to rain or use in damp locations.
	Read The Operator's Manual	To reduce the risk of injury, user must read and understand operator's manual before using this product.
	Eye Protection	Always wear safety goggles or safety glasses with side shields and a full face shield when operating this product.
	Safety Alert	Precautions that involve your safety.
	No Hands Symbol	Failure to keep your hands away from the blade will result in serious personal injury.
	No Hands Symbol	Failure to keep your hands away from the blade will result in serious personal injury.
	No Hands Symbol	Failure to keep your hands away from the blade will result in serious personal injury.
	No Hands Symbol	Failure to keep your hands away from the blade will result in serious personal injury.
	Hot Surface	To reduce the risk of injury or damage, avoid contact with any hot surface.

# SYMBOLS

The following signal words and meanings are intended to explain the levels of risk associated with this product.

SYMBOL	SIGNAL	MEANING
	<b>DANGER:</b>	Indicates an imminently hazardous situation, which, if not avoided, will result in death or serious injury.
	<b>WARNING:</b>	Indicates a potentially hazardous situation, which, if not avoided, could result in death or serious injury.
	<b>CAUTION:</b>	Indicates a potentially hazardous situation, which, if not avoided, may result in minor or moderate injury.
	<b>CAUTION:</b>	(Without Safety Alert Symbol) Indicates a situation that may result in property damage.

## SERVICE

Servicing requires extreme care and knowledge and should be performed only by a qualified service technician. For service we suggest you return the product to your nearest **AUTHORIZED SERVICE CENTER** for repair. When servicing, use only identical replacement parts.

 **WARNING:** To avoid serious personal injury, do not attempt to use this product until you read thoroughly and understand completely the operator's manual. Save this operator's manual and review frequently for continuing safe operation and instructing others who may use this product.

## WARNING:



The operation of any power tool can result in foreign objects being thrown into your eyes, which can result in severe eye damage. Before beginning power tool operation, always wear safety goggles or safety glasses with side shields and a full face shield when needed. We recommend Wide Vision Safety Mask for use over eyeglasses or standard safety glasses with side shields. Always use eye protection which is marked to comply with ANSI Z87.1.

## SAVE THESE INSTRUCTIONS

# ELECTRICAL

## DOUBLE INSULATION

Double insulation is a concept in safety in electric power tools, which eliminates the need for the usual three-wire grounded power cord. All exposed metal parts are isolated from the internal metal motor components with protecting insulation. Double insulated tools do not need to be grounded.

 **WARNING:** The double insulated system is intended to protect the user from shock resulting from a break in the tool's internal insulation. Observe all normal safety precautions to avoid electrical shock.

Servicing of a tool with double insulation requires extreme care and knowledge of the system and should be performed only by a qualified service technician. For service, we suggest you return the tool to your nearest authorized service center for repair. Always use original factory replacement parts when servicing.

## ELECTRICAL CONNECTION

This tool has a precision-built electric motor. It should be connected to a **power supply that is 120 volts, 60 Hz, AC only (normal household current)**. Do not operate this tool on direct current (DC). A substantial voltage drop will cause a loss of power and the motor will overheat. If your tool does not operate when plugged into an outlet, double-check the power supply.

## EXTENSION CORDS

When using a power tool at a considerable distance from a power source, be sure to use an extension cord that has the capacity to handle the current the tool will draw. An undersized cord will cause a drop in line voltage, resulting in overheating and loss of power. Use the chart to determine the minimum wire size required in an extension cord. Only round jacketed cords listed by Underwriter's Laboratories (UL) should be used.

When working outdoors with a tool, use an extension cord that is designed for outside use. This type of cord is designated with "WA" on the cord's jacket.

Before using any extension cord, inspect it for loose or exposed wires and cut or worn insulation.

\*\*Ampere rating  
(on tool faceplate) 0-2.0 2.1-3.4 3.5-5.0 5.1-7.0 7.1-12.0 12.1-16.0

Cord Length	Wire Size (A.W.G.)					
25'	16	16	16	16	14	14
50'	16	16	16	14	14	12
100'	16	16	14	12	10	—

\*\*Used on 12 gage - 20 amp circuit.

**NOTE:** AWG = American Wire Gauge

 **WARNING:** Keep the extension cord clear of the working area. Position the cord so that it will not become entangled in the rotating foam pad or caught on lumber, tools or other obstructions while you are working with a power tool. Failure to do so can result in serious personal injury.

 **WARNING:** Check extension cords before each use. If damaged replace immediately. Never use tool with a damaged cord since touching the damaged area could cause electrical shock resulting in serious injury.



# GLOSSARY OF TERMS FOR WOODWORKING

**Arbor**

The shaft on which a blade or cutting tool is mounted.

**Bevel Cut**

A cutting operation made with the blade at any angle other than 90° to the miter table.

**Crosscut**

A cutting or shaping operation made across the grain of the workpiece.

**Compound Miter Cut**

A compound miter cut is a cut made using a miter angle and a bevel angle at the same time.

**Freehand**

Performing a cut without using a fence, miter gage, fixture, work clamp, or other proper device to keep the workpiece from twisting or moving during the cut.

**Gum**

A sticky, sap based residue from wood products.

**Miter Cut**

A cutting operation made with the blade at any angle other than 90° to the fence.

**Resin**

A sticky, sap base substance that has hardened.

**Revolutions Per Minute (RPM)**

The number of turns completed by a spinning object in one minute.

**Saw Blade Path**

The area over, under, behind, or in front of the blade. As it applies to the workpiece, that area which will be, or has been, cut by the blade.

**Set**

The distance that the tip of the sawblade tooth is bent (or set) outward from the face of the blade.

**Throw-Back**

Throwing of a workpiece in a manner similar to a kick-back. Usually associated with a cause other than the kerf closing, such as a workpiece not being against the fence, being dropped into the blade, or being placed inadvertently in contact with the blade.

**Through Sawing**

Any cutting operation where the blade extends completely through the thickness of the workpiece.

**Workpiece**

The item on which the cutting operation is being done. The surfaces of a workpiece are commonly referred to as faces, ends, and edges.

**Zero Clearance Throat Plate**

A plastic throat plate inserted in the miter table that allows for blade clearance. When you make your first cut with your compound miter saw, the saw blade cuts a slot through the throat plate the exact width of the blade. This provides for a zero clearance kerf that minimizes workpiece tear-out.

**No Hands Zone**

The area between the marked lines on the left and right side of the miter table base. This zone is identified by no hands zone labels placed inside the marked lines on the miter table base.

# FEATURES

## Product Specifications:

Blade Diameter ..... 10 in.  
 Blade Arbor ..... 5/8 in.  
 No Load Speed ..... 5500/min.  
 Input ..... 120 Volts, 60 Hz-AC Only, 14 Amperes  
 Net Weight ..... 30 lbs.

When the miter angle (miter table) is set at 0° and the bevel angle is set at 0°:  
 Maximum nominal lumber sizes: 4 x 4, 2 x 6

When the miter angle (miter table) is set at 45° and the bevel angle is set at 0°:  
 Maximum nominal lumber sizes: 2 x 4

When the miter angle (miter table) is set at 0° and the bevel angle is set at 45°:  
 Maximum nominal lumber sizes: 2 x 6

When the miter angle (miter table) is set at 45° and the bevel angle is set at 45°:  
 Maximum nominal lumber sizes: 2 x 4

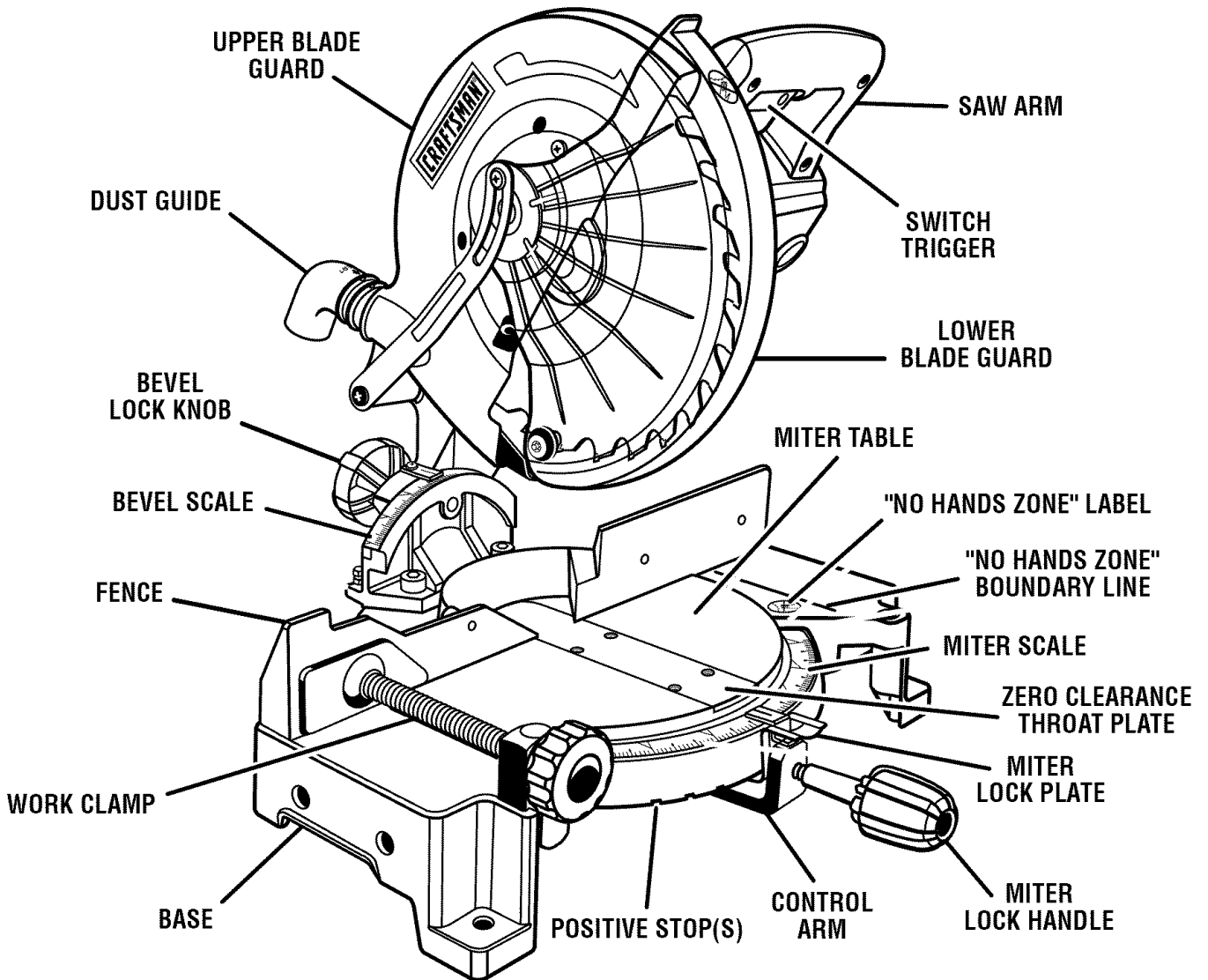

Fig. 1

# FEATURES

## KNOW YOUR COMPOUND MITER SAW

See Figure 1.

Before attempting to use this product, familiarize yourself with all operating features and safety requirements.

### 14 AMP MOTOR

Your saw has a powerful 14 amp motor with sufficient power to handle tough cutting jobs. It is made with all ball bearings, and has externally accessible brushes for ease of servicing.

### 10 in. BLADE

A 10 in. saw blade is included with your compound miter saw. It will cut materials up to 2 in. thick or 6 in. wide, depending upon the angle at which the cut is being made.

### CARRYING HANDLE

See Figure 2.

For convenience when carrying or transporting your miter saw from one place to another, a carrying handle has been provided on top of the saw arm as shown in figure 2. To transport, turn off and unplug your saw, then lower the saw arm and lock it in the down position. Lock saw arm by depressing the lock pin.

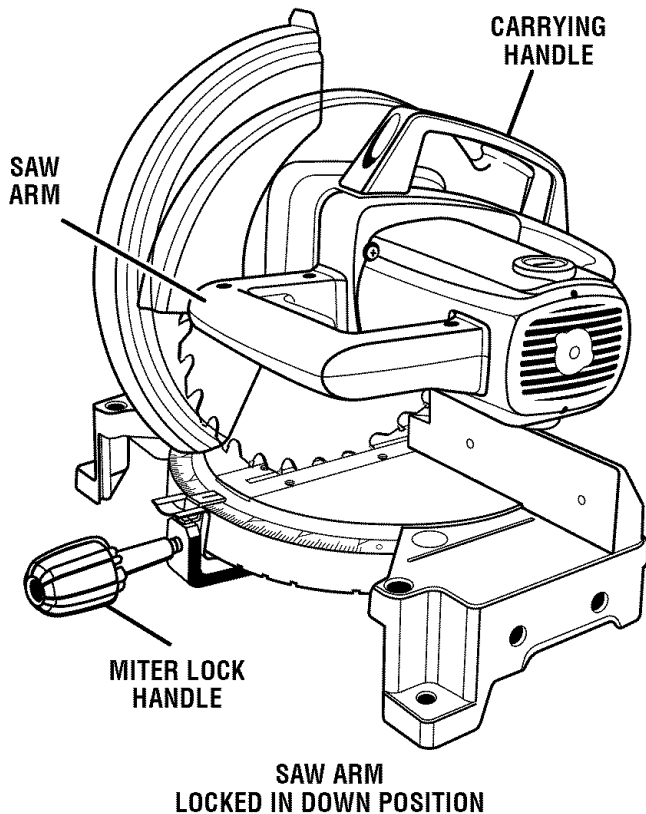

Fig. 2

### MITER LOCK HANDLE

See Figure 2.

The miter lock handle securely locks your saw at desired miter angles.

## SPINDLE LOCK BUTTON

See Figure 3.

A spindle lock button has been provided for locking the spindle which keeps the blade in your saw from rotating. Depress and hold the lock button while installing, changing, or removing blade.

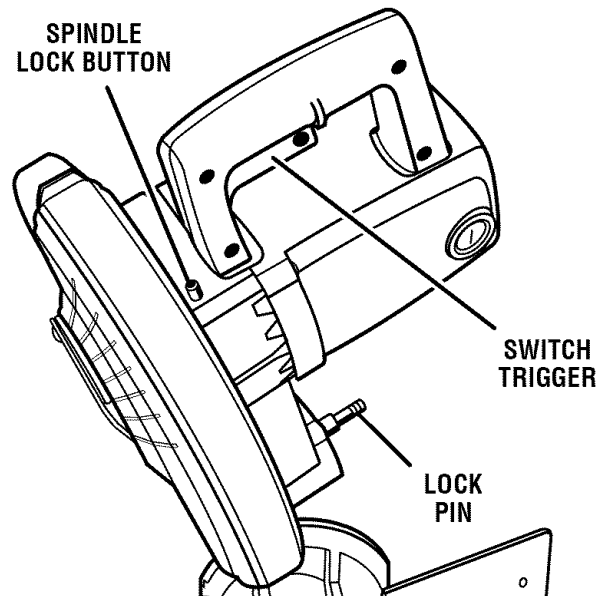

Fig. 3

## TRIGGER LOCK

See Figure 4.

To prevent unauthorized use of your compound miter saw, we suggest that you disconnect it from the power supply and lock the switch in the off position. To lock the switch, install a padlock (not included) through the hole in the switch trigger. A lock with a long shackle up to 17/64 in. diameter may be used. When the lock is installed and locked, the switch is inoperable. Store the padlock key in another location.

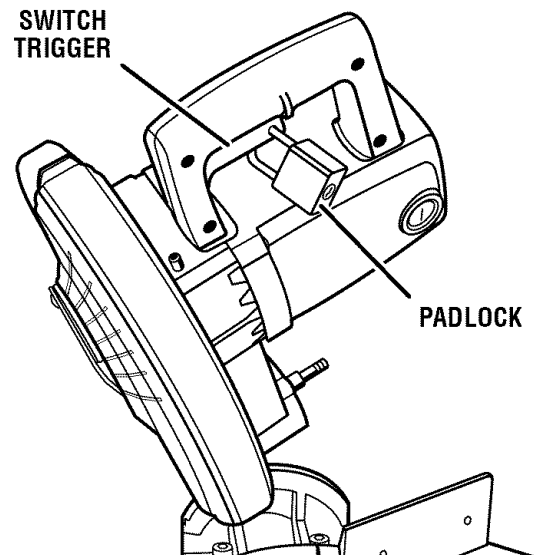

Fig. 4

# FEATURES

## POSITIVE STOPS ON MITER TABLE

Positive stops have been provided at 0°, 15°, 22-1/2°, 30°, and 45°. The 0°, 15°, 22-1/2°, 30°, and 45° positive stops have been provided on both the left and right side of the miter table.

## BEVEL LOCK KNOB

The bevel lock knob securely locks your compound miter saw at desired bevel angles. A positive stop adjustment screw has been provided on each side of the saw arm. These adjustment screws are for making fine adjustments at 0° and 45°.

## ELECTRIC BRAKE

An electric brake has been provided to quickly stop blade rotation after the switch is released.

## FENCE

The fence on your compound miter saw has been provided as a support to hold your workpiece securely against when making all cuts.

## SELF-RETRACTING LOWER BLADE GUARD

The lower blade guard is made of shock-resistant, see-through plastic that provides protection from each side of the blade. It retracts over the upper blade guard as the saw is lowered into the workpiece.

## MOUNTING HOLES

See Figure 5.

Your compound miter saw should be permanently mounted to a firm supporting surface such as a workbench. Four bolt holes have been provided in the saw base for this purpose. Each of the four mounting holes should be bolted securely using 3/8 in. machine bolts, lock washers, and hex nuts (not included). Bolts should be of sufficient length to accommodate the saw base, lock washers, hex nuts, and the thickness of the workbench.

Tighten all four bolts securely.

The hole pattern for mounting to a workbench is shown in figure 5. Carefully check the workbench after mounting to make sure that no movement can occur during use. If any tipping, sliding, or walking is noted, secure the workbench to the floor before operating.

**⚠ WARNING:** Always make sure your compound miter saw is securely mounted to a workbench or an approved workstand. Failure to do so could result in an accident resulting in possible serious personal injury.

## ELECTRICAL CONNECTION

Your saw has a precision built electric motor. It should be connected to a **power supply that is 120 volts, 60 Hz, AC only (normal household current)**. Do not operate this tool on direct current (DC). A substantial voltage drop will cause a loss of power and the motor will overheat. If your tool does not operate when plugged into an outlet, double-check the power supply.

**⚠ WARNING:** The operation of any saw can result in foreign objects being thrown into your eyes, which can result in severe eye damage. Before starting power tool operation, always wear safety goggles or safety glasses with side shields and a full face shield when needed. We recommend wide vision safety mask for use over eyeglasses or standard safety glasses with side shields.

**⚠ WARNING:** Do not attempt to modify this tool or create accessories not recommended for use with this tool. Any such alteration or modification is misuse and could result in a hazardous condition leading to possible serious personal injury.

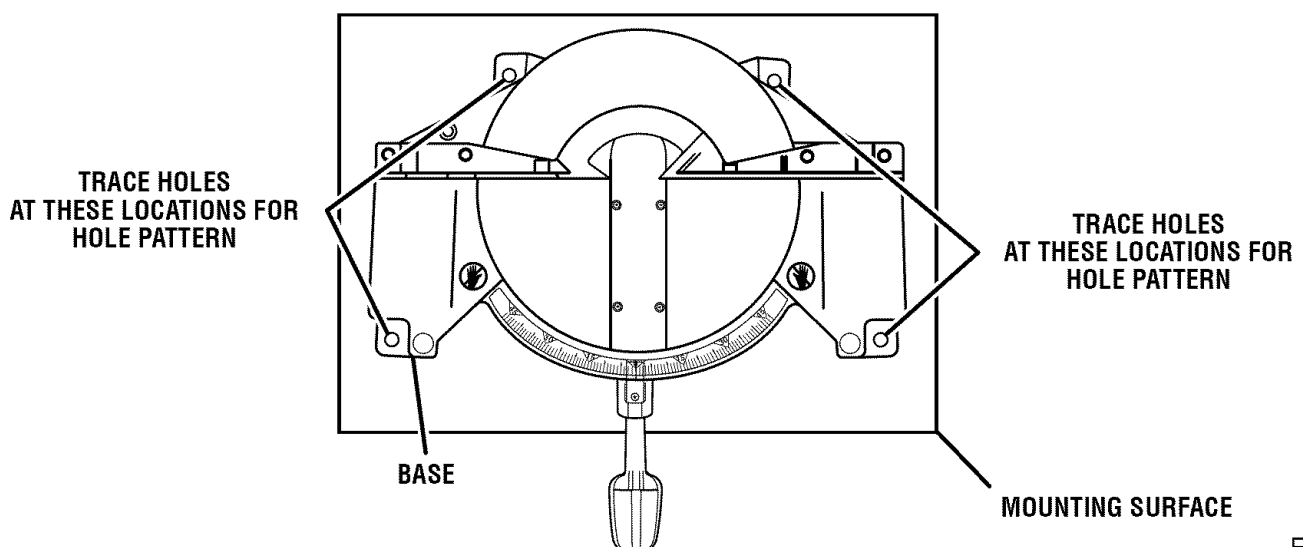

# UNPACKING

This product has been shipped completely assembled except for the blade, miter lock handle, dust bag, and dust guide.

- Carefully lift saw from the carton by the carrying handle and the saw base, and place it on a level work surface.

**NOTE:** This saw is heavy. To avoid back injury, lift with your legs, not your back, and get help when needed.

- Your saw has been shipped with the saw arm secured in the down position. To release the saw arm, push down on the top of the saw arm, cut the tie-wrap, and pull out on the lock pin.
- Lift the saw arm by the handle. Hand pressure should remain on the saw arm to prevent sudden rise upon release of the tie wrap.
- Inspect the tool carefully to make sure no breakage or damage occurred during shipping.

- Do not discard the packing material until you have carefully inspected and satisfactorily operated the tool.
- The saw is factory set for accurate cutting. After assembling it, check for accuracy. If shipping has influenced the settings, refer to specific procedures explained in this manual.
- If any parts are damaged or missing, please call 1-800-932-3188 for assistance.

**⚠ WARNING:** Do not attempt to modify this tool or create accessories not recommended for use with this tool. Any such alteration or modification is misuse and could result in a hazardous condition leading to possible serious personal injury.

**⚠ WARNING:** If any parts are missing, do not operate this tool until the missing parts are replaced. Failure to do so could result in possible serious personal injury.

# TOOLS NEEDED

The following tools (**not included**) are needed for checking adjustments of your saw or for installing the blade:

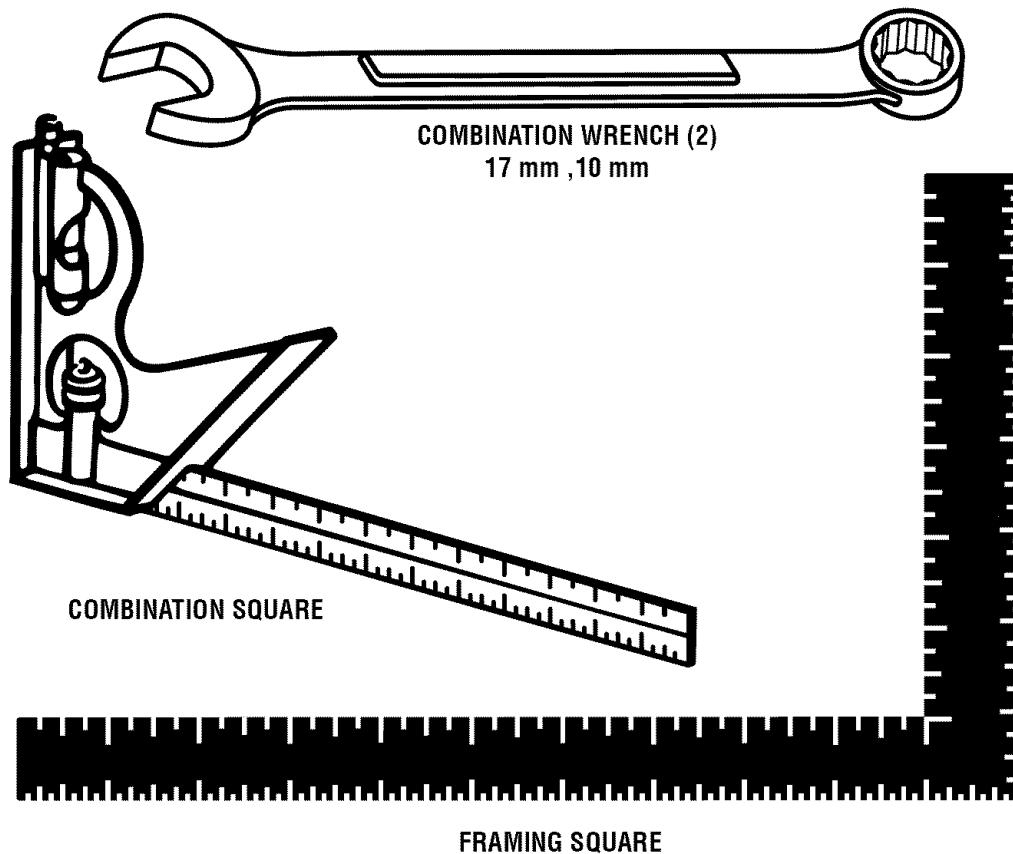

Fig. 6

# LOOSE PARTS LIST

The following items are included with your Compound Miter Saw:

- Saw Blade - 10 in.
- Miter Lock Handle
- Dust Bag
- Dust Guide
- 5 mm Hex Key
- 8 mm Hex Key
- 6 mm Blade Wrench
- Operator's Manual

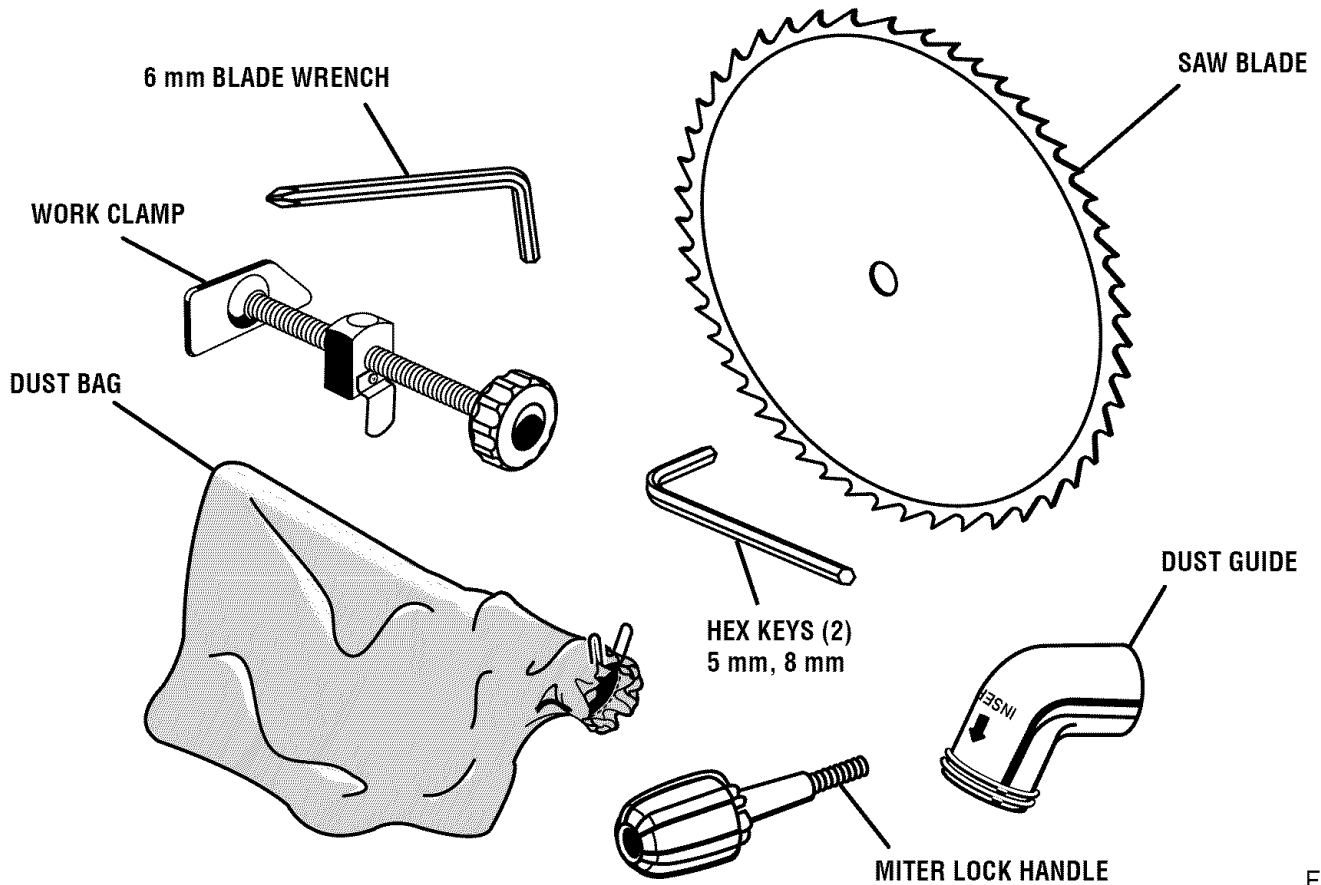

Fig. 7

**WARNING:** The use of attachments or accessories not listed might be hazardous and could cause serious personal injury.

# ASSEMBLY

**WARNING:** Do not connect to power supply until assembly is complete. Failure to comply could result in accidental starting and possible serious personal injury.

As mentioned previously, your saw has been factory assembled and adjusted. The miter lock handle, dust guide, and blade are the only parts that have to be installed.

## MITER LOCK HANDLE

See Figure 8.

Cut the tie-wraps holding the saw arm and the miter lock in place. To install the miter lock handle, place the threaded stud into the threaded hole in the control arm. Turn clockwise to tighten.

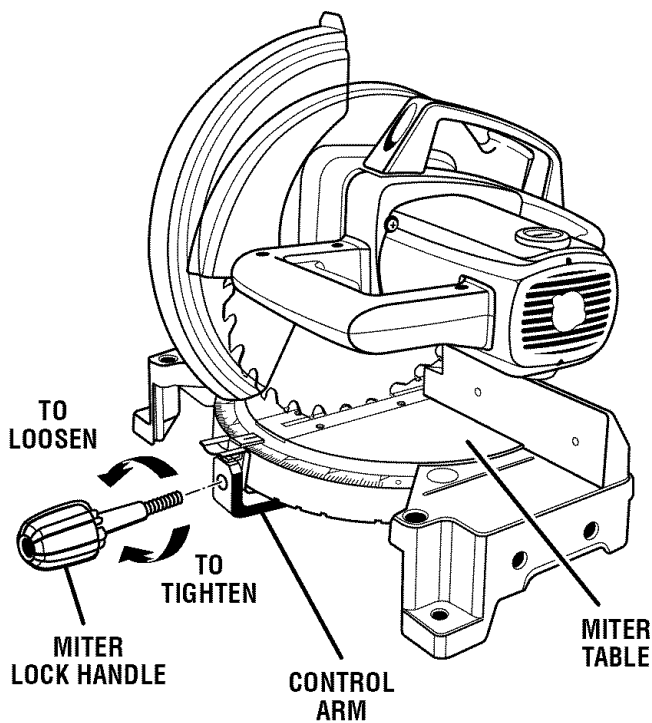

Fig. 8

## DUST GUIDE

See Figure 9.

To install the dust guide, place the end marked **INSERT** over the exhaust port in the upper blade guard. Turn the guide so that the open end is facing down or toward the rear of the saw.

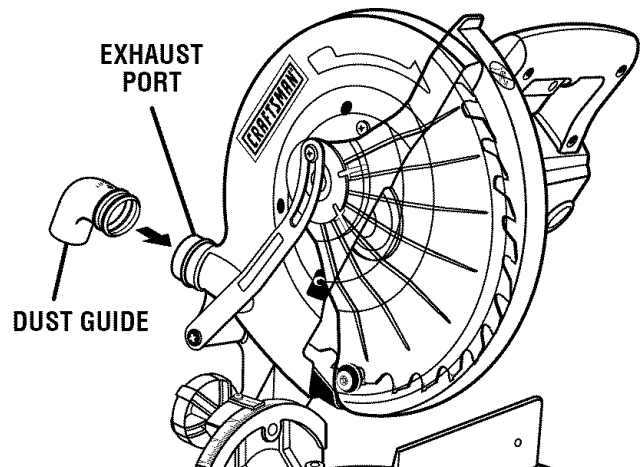

Fig. 9

## DUST BAG

See Figure 10.

A dust bag is provided for use on your miter saw. It fits over the dust guide on the upper blade guard. To install, squeeze the two metal clips to open the mouth of the bag and slide it on to the dust guide. Release the clips. The metal ring in the bag should lock in between the grooves on the dust guide.

To remove the dust bag for emptying, simply reverse the above procedure.

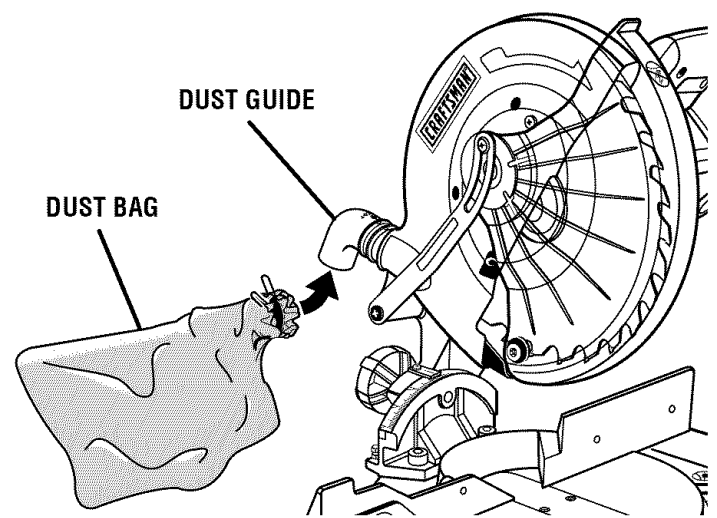

Fig. 10

# ASSEMBLY

## WORK CLAMP

See Figure 11.

The work clamp provides greater control by clamping the workpiece to the fence or the saw table. It also prevents the workpiece from creeping toward the saw blade. This is very helpful when cutting compound miters.

Depending on the cutting operation and the size of the workpiece, it may be necessary to use a C-clamp instead of the work clamp to secure the workpiece prior to making the cut.

**WARNING:** In some operations, the work clamp assembly may interfere with the operation of the blade guard assembly. Always make sure there is no interference with the blade guard prior to beginning any cutting operation to reduce the risk of serious personal injury.

Follow these directions to install the work clamp:

- Place the shaft of the work clamp in either hole on the saw table base.
- Rotate the knob on the work clamp to move it in or out as needed.

**WARNING:** When using any clamp with a stop block, install the clamp on the same side as the stop block. This will eliminate the possibility of trapping the workpiece, resulting in the saw blade and workpiece kicking up. Failure to heed this warning can result in serious personal injury.

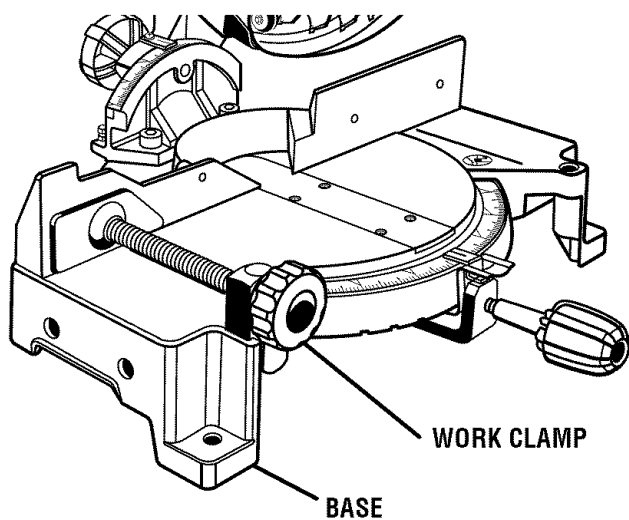

Fig. 11

## TO INSTALL BLADE

See Figures 12, 13, and 14.

**WARNING:** A 10 in. blade is the maximum blade capacity of your saw. Never use a blade that is too thick to allow outer blade washer to engage with the flats on the spindle. Larger blades will come in contact with the blade guards, while thicker blades will prevent the blade screw from securing the blade on the spindle. Either of these situations could result in a serious accident and can cause serious personal injury.

- Unplug your saw.

**WARNING:** Failure to unplug your saw could result in accidental starting causing possible serious personal injury.

- Loosen the phillips screw on the blade bolt cover until blade bolt cover can be raised. See Figures 12 and 13.
- Gently raise the lower blade guard bracket, releasing lower blade guard from notch so that lower blade guard and blade bolt cover can be rotated up and back to expose the blade bolt. See Figures 12 and 13.
- Depress the spindle lock button and rotate the blade bolt until the spindle locks. See Figure 13.
- Using the blade wrench provided, loosen and remove the blade bolt.

**NOTE:** The blade bolt has left hand threads. Turn blade bolt clockwise to loosen.

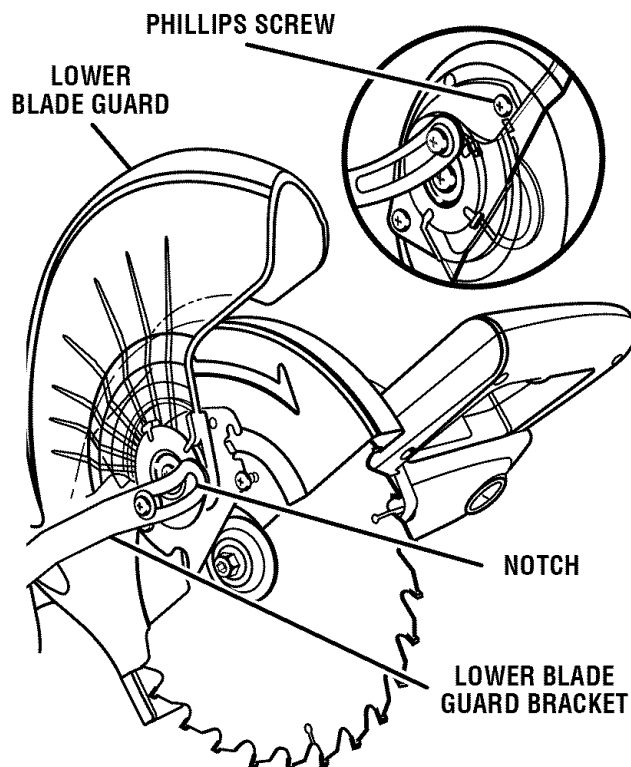

Fig. 12



# ASSEMBLY

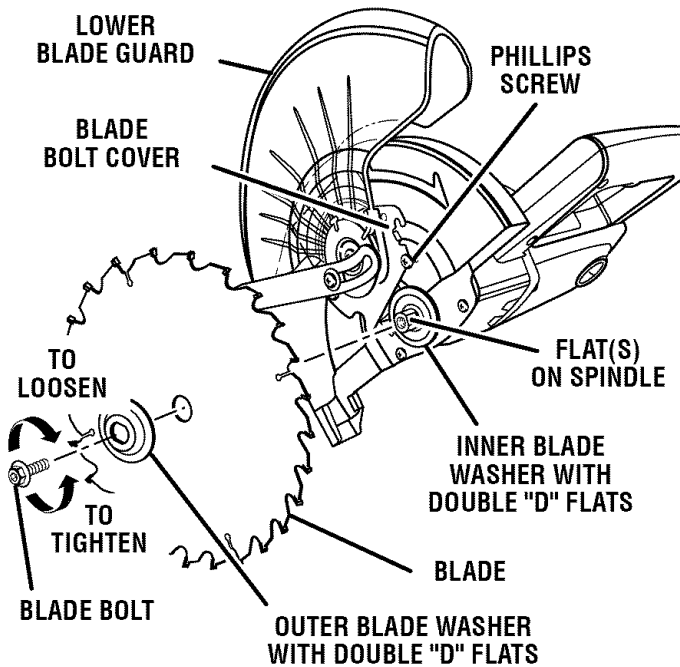

Fig. 13

- Remove outer blade washer. **Do not** remove inner blade washer.
- Wipe a drop of oil onto inner blade washer and outer blade washer where they contact the blade.

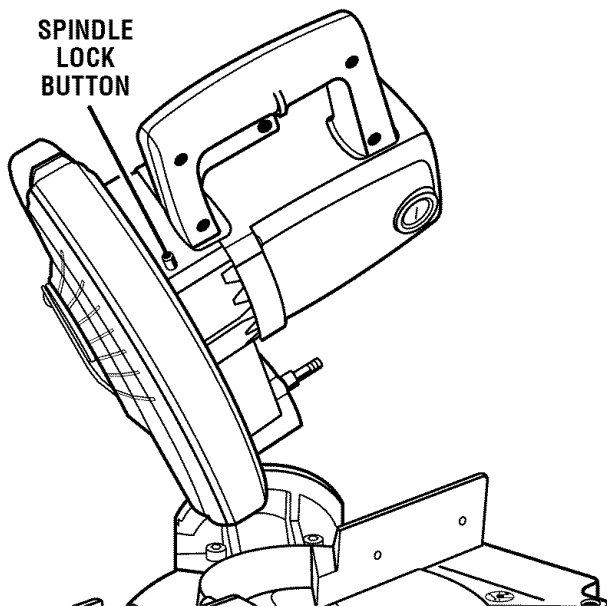

Fig. 14

**WARNING:** If inner blade washer has been removed, replace it before placing blade on spindle. Failure to do so could cause an accident since blade will not tighten properly.

- Fit saw blade inside lower blade guard and onto spindle. The blade teeth point downward at the front of saw as shown in figure 13.

**CAUTION:** Always install the blade with the blade teeth and the arrow printed on the side of the blade pointing down at the front of the saw. The direction of blade rotation is also stamped with an arrow on the upper blade guard.

- Replace outer blade washer. The double "D" flats on the blade washers align with the flats on the spindle.
- Depress spindle lock button and replace blade bolt. *See Figure 14.*

**NOTE:** The blade bolt has left hand threads. Turn blade bolt counterclockwise to tighten.

- Tighten blade bolt securely.
- Remove the hex key and store it in rubber grommet behind left-hand fence.
- Replace the lower blade guard and blade bolt cover.
- Retighten phillips screw securing blade bolt cover. Tighten screw securely. *See Figure 13.*

**WARNING:** Make sure the spindle lock button is not engaged before reconnecting saw into power source. Never engage spindle lock button when blade is rotating.

Your compound miter saw has been adjusted at the factory for making very accurate cuts. However, some of the components might have moved out of alignment during shipping. Also, over a period of time, readjustment will probably become necessary due to wear. After unpacking your saw, check the following adjustments before you begin using saw. Make any readjustments that are necessary and periodically check the parts alignment to make sure that your saw is cutting accurately.

**WARNING:** Your saw should never be connected to a power supply when you are assembling parts, making adjustments, installing or removing blades, or when not in use. Disconnecting your saw will prevent accidental starting that could cause serious injury.

# ASSEMBLY

**NOTE:** Many of the illustrations in this manual show only portions of your compound miter saw. This is intentional so that we can clearly show points being made in the illustrations. **Never operate your saw without all guards securely in place and in good operating condition.**

## SQUARING THE MITER TABLE TO THE FENCE

See Figures 15 - 18.

- Unplug your saw.

**WARNING:** Failure to unplug your saw could result in accidental starting causing possible serious personal injury.

- Push down on the saw arm and pull out the lock pin to release the saw arm.
- Raise saw arm to its full raised position.
- Loosen the miter lock handle approximately one-half turn.
- Depress the miter lock plate and rotate the miter table until the pointer on the control arm is positioned at 0°.
- Release the miter lock plate and securely tighten the miter lock handle.
- Lay a framing square flat on the miter table. Place one leg of the square against the fence. Place the other leg of the square beside the zero clearance throat plate in the miter table. The edge of the square and the zero clearance throat plate in the miter table should be parallel as shown in figure 15.
- If the edge of the framing square and the zero clearance throat plate in the miter table are not parallel as shown in figures 16 and 17, adjustments are needed.

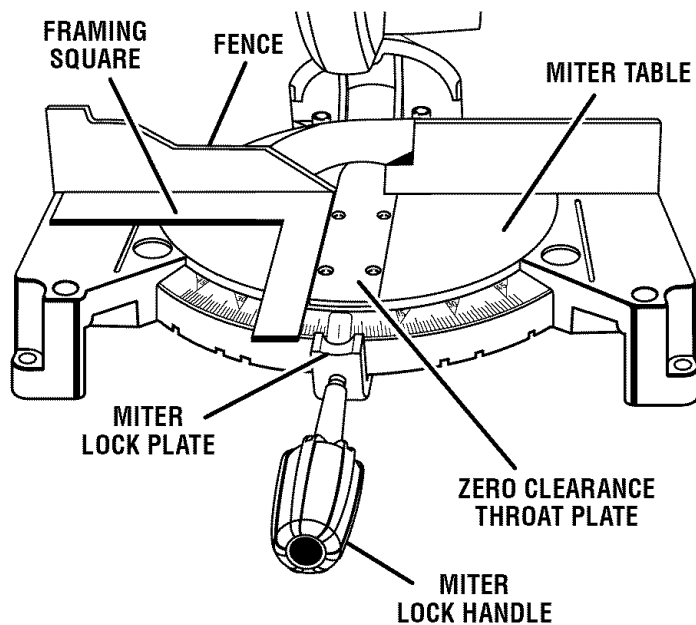

VIEW OF MITER TABLE SQUARE WITH FENCE  
CORRECTLY ADJUSTED

Fig. 15

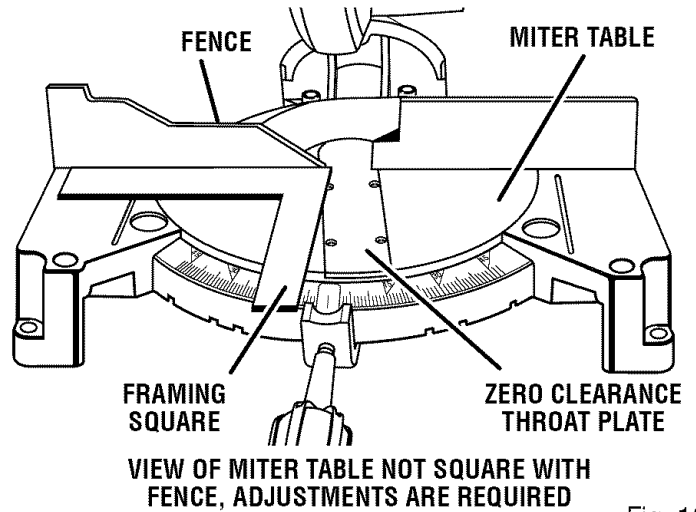

Fig. 16

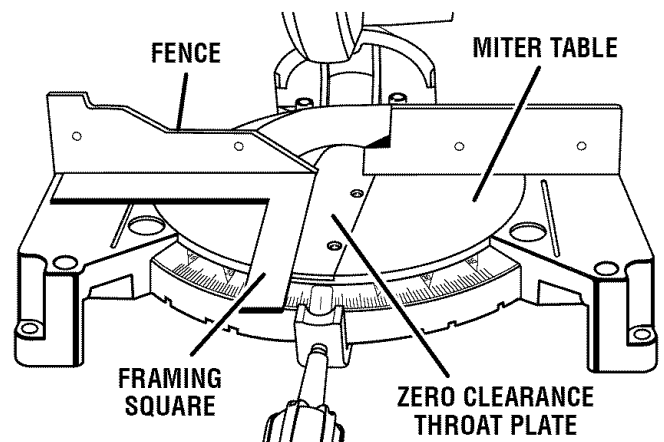

Fig. 17

- Using the blade wrench, loosen the socket head screws securing the fence. See Figure 18. Adjust the fence left or right until the framing square and zero clearance throat plate are parallel.
- Retighten the screws securely and recheck the fence-to-table alignment.

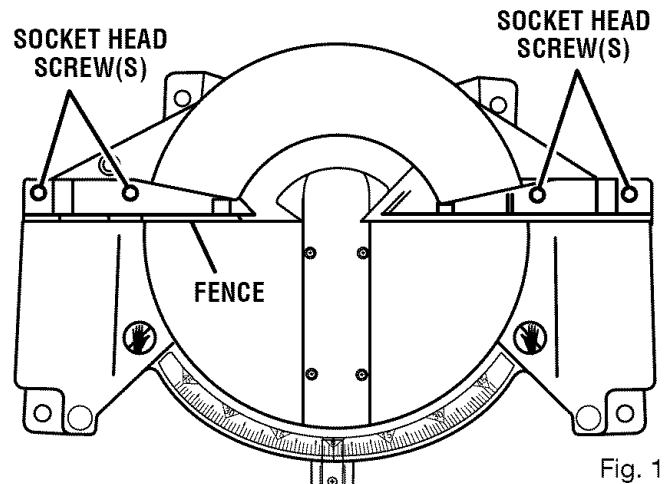

Fig. 18

# ASSEMBLY

## CUTTING A SLOT IN THE ZERO CLEARANCE THROAT PLATE

In order to use your compound miter saw, you must cut a slot through the zero clearance throat plate to allow for blade clearance. To cut the slot, set your saw at 0° miter, turn saw on and allow the blade to reach full speed, then carefully make a straight cut as far as it will go through the throat plate. Turn your saw off and allow the blade to come to a complete stop before raising the saw arm.

Next, adjust the bevel angle to 45°, turn your saw on and allow the blade to reach full speed, then carefully make another cut through the zero clearance throat plate. The slot in the throat plate will then be wide enough to allow the blade to pass through it at any angle from 0° to 45°.

## SQUARING THE SAW BLADE TO THE FENCE

See Figures 19 - 22.

- Unplug your saw.

**WARNING:** Failure to unplug your saw could result in accidental starting causing possible serious personal injury.

- Remove the screws securing the throat plate then remove the throat plate. Save the screws and throat plate for later reinstallation.
- Pull the saw arm all the way down and engage the lock pin to hold the saw arm in transport position.
- Loosen the miter lock handle approximately one-half turn.
- Depress the miter lock plate and rotate the miter table until the pointer on the control arm is positioned at 0°.
- Release the miter lock plate and securely tighten the miter lock handle.
- Lay a framing square flat on the miter table. Place one leg of the square against the fence. Slide the other leg of the square against the flat part of saw blade.

**NOTE:** Make sure that the square contacts the flat part of the saw blade, not the blade teeth.

- The edge of the square and the saw blade should be parallel as shown in figure 19.
- If the front or back edge of the saw blade angles away from the square as shown in figures 20 and 21, adjustments are needed.
- Using a 8 mm hex key, loosen the socket head screws that secure the mounting bracket to the miter table. See Figure 22.
- Rotate the mounting bracket left or right until the saw blade is parallel with the square.
- Retighten the screws securely and recheck the blade-to-fence alignment.
- Reinstall the throat plate and securely tighten the screws.

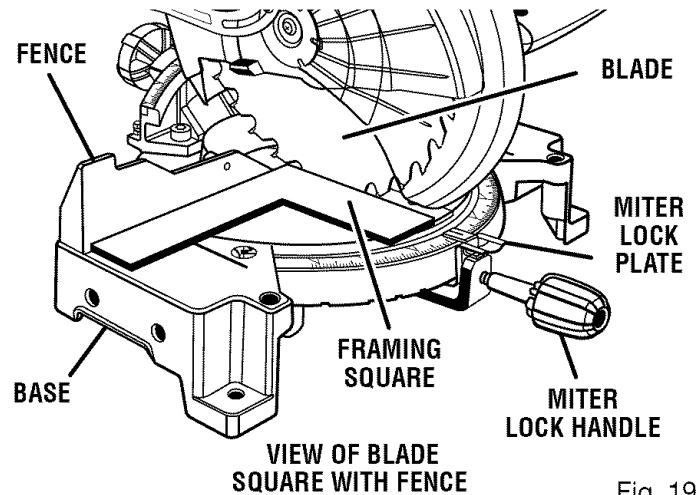

Fig. 19

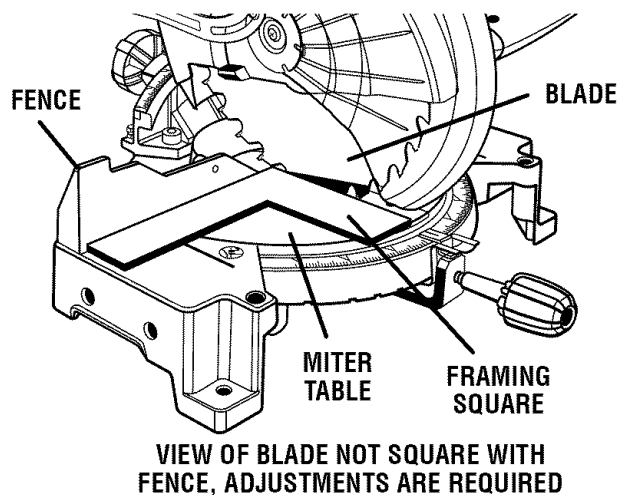

Fig. 20

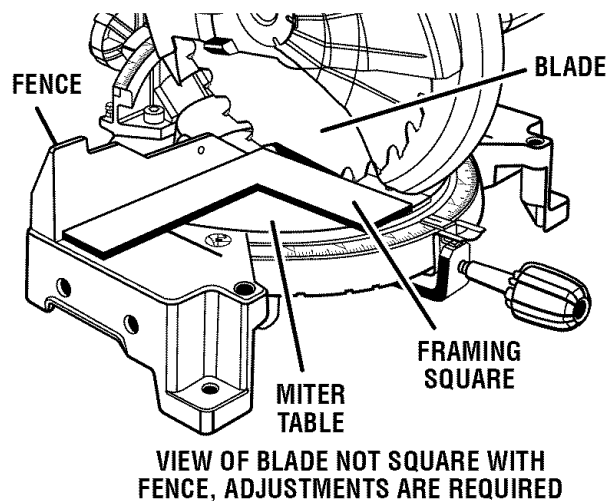

Fig. 21

# ASSEMBLY

## SQUARING THE BLADE TO THE MITER TABLE

See Figures 23 - 25.

- Unplug your saw.

**⚠ WARNING:** Failure to unplug your saw could result in accidental starting causing possible serious personal injury.

- Pull the saw arm all the way down and engage the lock pin to hold the saw arm in transport position.
- Loosen the miter lock handle approximately one-half turn.
- Depress the miter lock plate and rotate the miter table until the pointer on the control arm is positioned at 0°.
- Release the miter lock plate and securely tighten the miter lock handle.
- Loosen bevel lock knob and set saw arm at 0° bevel (blade set 90° to miter table). Tighten bevel lock knob.
- Place a combination square against the miter table and the flat part of saw blade.

**NOTE:** Make sure that the square contacts the flat part of the saw blade, not the blade teeth.

- Rotate the blade by hand and check the blade-to-table alignment at several points.
- The edge of the square and the saw blade should be parallel as shown in figure 23.
- If the top or bottom of the saw blade angles away from the square as shown in figures 24 and 25, adjustments are needed.
- Using a 10 mm wrench or adjustable wrench, loosen the lock nut securing positive stop adjustment screw. Also loosen bevel lock knob. See Figure 36.
- Adjust positive stop adjustment screw to bring saw blade into alignment with the square.
- Retighten bevel lock knob. Next, retighten lock nut securing the positive stop adjustment screw. Recheck blade-to-table alignment.

**NOTE:** The above procedure can be used to check blade squareness of the saw blade to the miter table at both 0° and 45° angles.

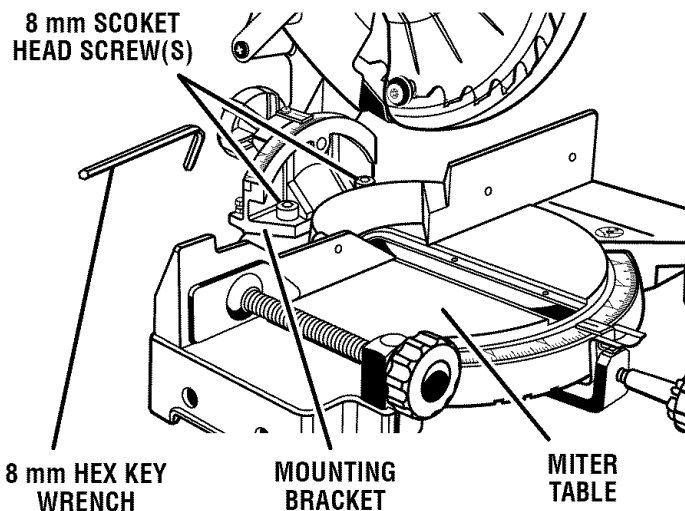

Fig. 22

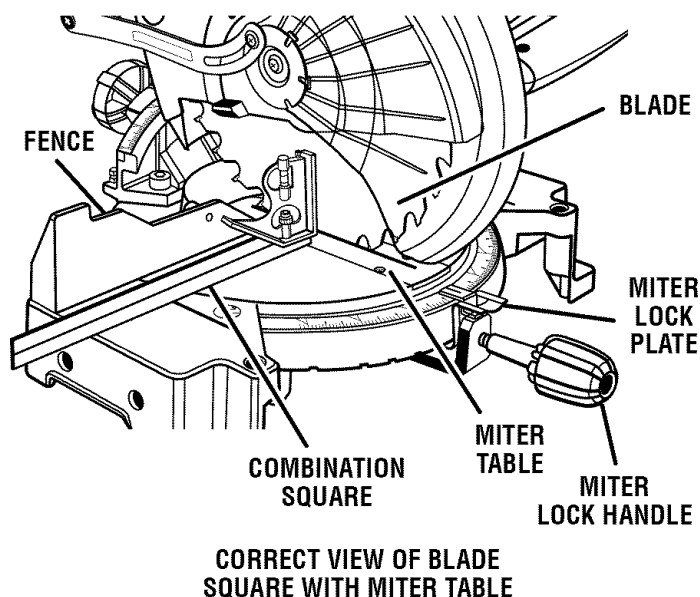

Fig. 23

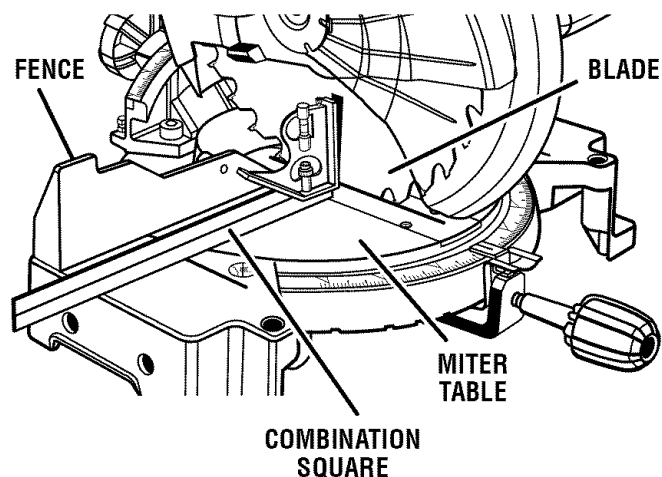
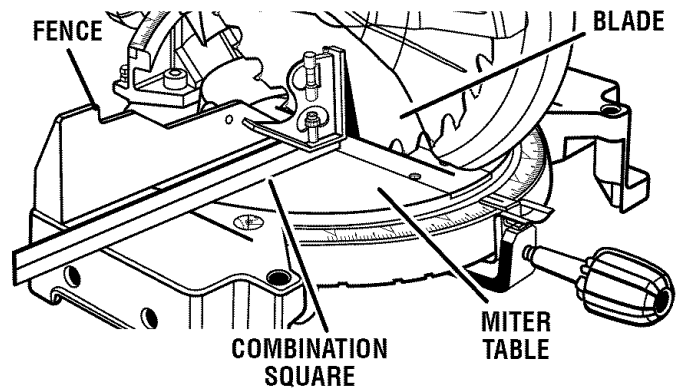

Fig. 24

# ASSEMBLY

Your saw has three scale indicators, two on either side of the bevel scale and one on the miter scale. After squaring adjustments have been made, it may be necessary to loosen the indicators screws and reset them to zero.



VIEW OF BLADE NOT SQUARE WITH MITER TABLE, ADJUSTMENTS ARE REQUIRED

Fig. 25

# OPERATION

**WARNING:** Do not allow familiarity with your tool to make you careless. Remember that a careless fraction of a second is sufficient to inflict severe injury.

**WARNING:** Always wear safety goggles or safety glasses with side shields when operating tools. Failure to do so could result in objects being thrown into your eyes, resulting in possible serious injury.

## APPLICATIONS

This product has been designed only for the purposes listed below:

- Cross cutting wood and plastic.
- Cross cutting miters, joints, etc. for picture frames, moldings, door casings, and fine joinery.

**NOTE:** The blade provided is fine for most wood cutting operations, but for fine joinery cuts or cutting plastic, use one of the accessory blades available from your nearest Sears store.

**WARNING:** Before starting any cutting operation, clamp or bolt your compound miter saw to a workbench. Never operate your miter saw on the floor or in a crouched position. Failure to heed this warning can result in serious personal injury.

## CUTTING WITH YOUR COMPOUND MITER SAW

**WARNING:** When using a work clamp or C-clamp to secure your workpiece, clamp workpiece on one side of the blade only. The workpiece must remain free on one side of the blade to prevent the blade from binding in workpiece. The workpiece binding the blade will cause motor stalling and kickback. This situation could cause an accident resulting in possible serious personal injury.

## CROSSCUTTING

See Figure 26.

A crosscut is made by cutting across the grain of the workpiece. A straight crosscut is made with the miter table set at the 0° position. Miter crosscuts are made with the miter table set at some angle other than zero.

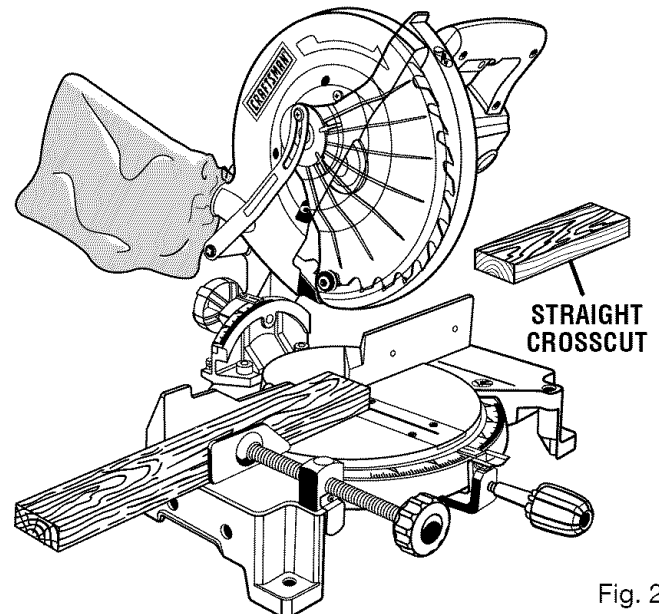

Fig. 26

# OPERATION

## TO CROSSCUT WITH YOUR MITER SAW

- Pull out the lock pin and lift saw arm to its full height.
- Loosen the miter lock handle. Rotate the miter lock handle approximately one-half turn to the left to loosen.
- Press the miter lock plate down with your thumb and hold.
- Rotate the control arm until the pointer aligns with the desired angle on the miter scale.
- Release the miter lock plate.

**NOTE:** You can quickly locate 0°, 15°, 22-1/2°, 30°, left or right, and 45° left or right by releasing the lock plate as you rotate the control arm. The lock plate will seat itself in one of the positive stop notches, located in the base.

- Tighten the miter lock handle securely.

**⚠ WARNING:** To avoid serious personal injury, always tighten the miter lock handle securely before making a cut. Failure to do so could result in movement of the control arm or miter table while making a cut.

- Place the workpiece flat on the miter table with one edge securely against the fence. If the board is warped, place the convex side against the fence. If the concave edge of a board is placed against the fence, the board could collapse on the blade at the end of the cut, jamming the blade.
- When cutting long pieces of lumber or molding, support the opposite end of the stock with a roller stand or with a work surface level with the saw table. *See Figure 31.*
- Align cutting line on the workpiece with the edge of saw blade.
- Grasp the stock firmly with one hand and secure it against the fence or use the optional work clamp or a C-clamp to secure the workpiece. *See Figure 26.*

**⚠ WARNING:** To avoid serious personal injury, keep your hands outside the no hands zone; at least 3 in. from blade. Never perform any cutting operation freehand (without holding workpiece against the fence). The blade could grab the workpiece if it slips or twists.

- Before turning on the saw, perform a dry run of the cutting operation just to make sure that no problems will occur when the cut is made.
- Grasp the saw handle firmly then squeeze the switch trigger. Allow several seconds for the blade to reach maximum speed.
- Slowly lower the blade into and through the workpiece. *See Figure 26.*
- Release the switch trigger and allow the saw blade to stop rotating before raising the blade out of workpiece. Wait until the electric brake stops blade from turning before removing the workpiece from the miter table.

## BEVEL CUT

*See Figures 27 and 28.*

A bevel cut is made by cutting across the grain of the workpiece with the blade angled to the workpiece. A straight bevel cut is made with the miter table set at the zero degree position and the blade set at an angle between 0° and 45°.

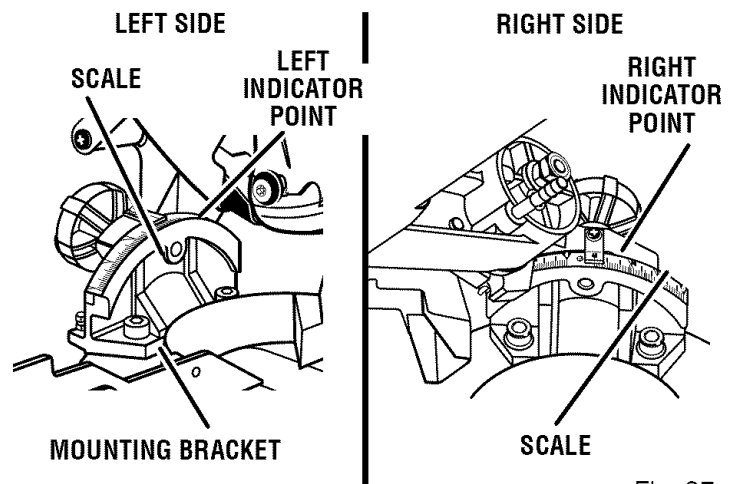

Fig. 27

# OPERATION

## TO BEVEL CUT WITH YOUR MITER SAW

- Pull out the lock pin and lift saw arm to its full height.
- Loosen the miter lock handle. Rotate the miter lock handle approximately one-half turn to the left to loosen.
- Press the miter lock plate down with your thumb and hold.
- Rotate the control arm until the pointer aligns with zero on the miter scale.
- Release the miter lock plate.

**NOTE:** You can quickly locate zero by releasing the lock plate as you rotate the control arm. The lock plate will seat itself in one of the built-in positive stop notches, located in the base.

- Tighten the miter lock handle securely.

**⚠ WARNING:** To avoid serious personal injury, always tighten the miter lock handle securely before making a cut. Failure to do so could result in movement of the control arm or miter table while making a cut.

- Loosen the bevel lock knob and move the saw arm to the left to the desired bevel angle.
- Bevel angles can be set from 0° to 45°.
- For your convenience there is a double scale located on the mounting bracket. *See Figure 27.* If one side becomes difficult to read as you move the saw arm to the left, simply refer to the other side. Align the indicator point for the side you choose with the desired angle.
- Once the saw arm has been set at the desired angle, securely tighten the bevel lock knob.
- Place the workpiece flat on the miter table with one edge securely against the fence. If the board is warped, place the convex side against the fence. If the concave edge of a board is placed against the fence, the board could collapse on the blade at the end of the cut, jamming the blade. *See Figures 33 and 34.*
- When cutting long pieces of lumber or molding, support the opposite end of the stock with a roller stand or with a work surface level with the saw table. *See Figure 31.*
- Align the cutting line on the workpiece with the edge of saw blade.
- Grasp the stock firmly with one hand and secure it against the fence or use the optional work clamp or a C-clamp to secure the workpiece. *See Figure 28.*

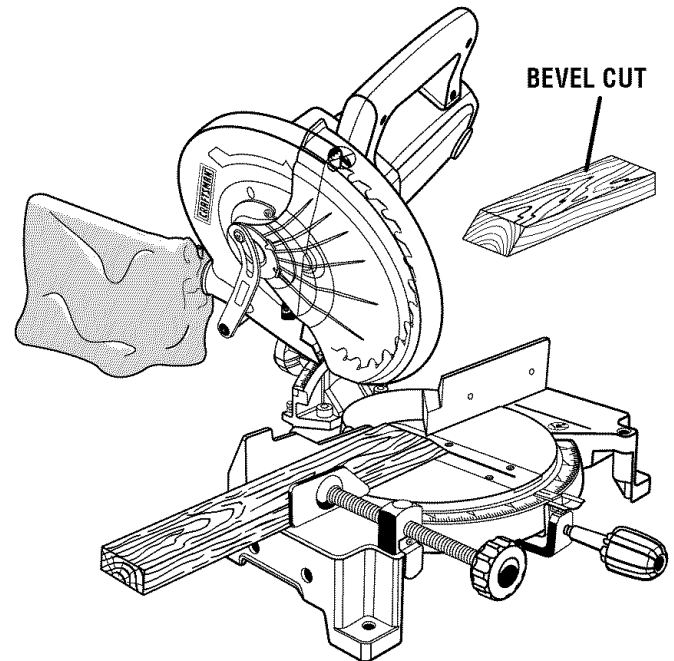

Fig. 28

**⚠ WARNING:** To avoid serious personal injury, keep your hands outside the no hands zone; at least 3 in. from blade. Never perform any cutting operation freehand (without holding workpiece against the fence). The blade could grab the workpiece if it slips or twists.

- Before turning on the saw, perform a dry run of the cutting operation just to make sure that no problems will occur when the cut is made.
- Grasp the saw handle firmly then squeeze the switch trigger. Allow several seconds for the blade to reach maximum speed.
- Slowly lower the blade into and through the workpiece. *See Figure 28.*
- Release the switch trigger and allow the saw blade to stop rotating before raising the blade out of workpiece. Wait until the electric brake stops blade from turning before removing the workpiece from miter table.

# OPERATION

## COMPOUND MITER CUT

A compound miter cut is a cut made using a miter angle and a bevel angle at the same time. This type of cut is used to make picture frames, cut molding, make boxes with sloping sides, and for certain roof framing cuts.

To make this type of cut the control arm on the miter table must be rotated to the correct angle and the saw arm must be tilted to the correct bevel angle. Care should always be taken when making compound miter setups due to the interaction of the two angle settings.

Adjustments of miter and bevel settings are interdependent with one another. Each time you adjust the miter setting you change the effect of the bevel setting. Also, each time you adjust the bevel setting you change the effect of the miter setting.

It may take several settings to obtain the desired cut. The first angle setting should be checked after setting the second angle, since adjusting the second angle affects the first.

Once the two correct settings for a particular cut have been obtained, always make a test cut in scrap material before making a finish cut in good material.

## TO MAKE A COMPOUND CUT WITH YOUR MITER SAW

- Pull out the lock pin and lift saw arm to its full height.
- Loosen the miter lock handle. Rotate the miter lock handle approximately one-half turn to the left to loosen.
- Press the miter lock plate down with your thumb and hold.
- Rotate the control arm until the pointer aligns with the desired angle on the miter scale.
- Release the miter lock plate.

**NOTE:** You can quickly locate 0°, 15°, 22-1/2°, 30°, left or right, and 45° left or right by releasing the miter lock plate as you rotate the control arm. The miter lock plate will seat itself in one of the positive stop notches, located in miter table frame.

- Tighten the miter lock handle securely.

**WARNING:** To avoid serious personal injury, always tighten the miter lock handle securely before making a cut. Failure to do so could result in movement of the control arm or miter table while making a cut.

- Loosen the bevel lock knob and move the saw arm to the left to the desired bevel angle.
- Bevel angles can be set from 0° to 45°.
- For your convenience there is a double scale located on the mounting bracket. See Figure 27. If one side becomes difficult to read as you move the saw arm to the left, simply refer to the other side. Align the indicator point for the side you choose with the desired angle.

- Once the saw arm has been set at the desired angle, securely tighten the bevel lock knob.
- Recheck miter angle setting. Make a test cut in scrap material.
- Place the workpiece flat on the miter table with one edge securely against the fence. If the board is warped, place the convex side against the fence. If the concave edge of a board could collapse on the blade at the end of the cut, jamming the blade. See Figures 33 and 34.
- When cutting long pieces of lumber or molding, support the opposite end of the stock with a roller stand or with a work surface level with the saw table. See Figure 31.
- Align the cutting line on the workpiece with the edge of saw blade.
- Grasp the stock firmly with one hand and secure it against the fence or use the optional work clamp or a C-clamp to secure the workpiece when possible. See Figure 29.

**NOTE:** When making a 45° left miter and a bevel angle greater than 30°, you must use a C-clamp to secure the workpiece or move clamp to the right side of the base.

**WARNING:** To avoid serious personal injury, always keep your hands outside the no hands zone; at least 3 in. from blade. Never perform any cutting operation freehand (without holding workpiece against the fence). The blade could grab the workpiece if it slips or twists.

- Before turning on the saw, perform a dry run of the cutting operation just to make sure that no problems will occur when the cut is made.
- Grasp the saw handle firmly then squeeze the switch trigger. Allow several seconds for the blade to reach maximum speed.

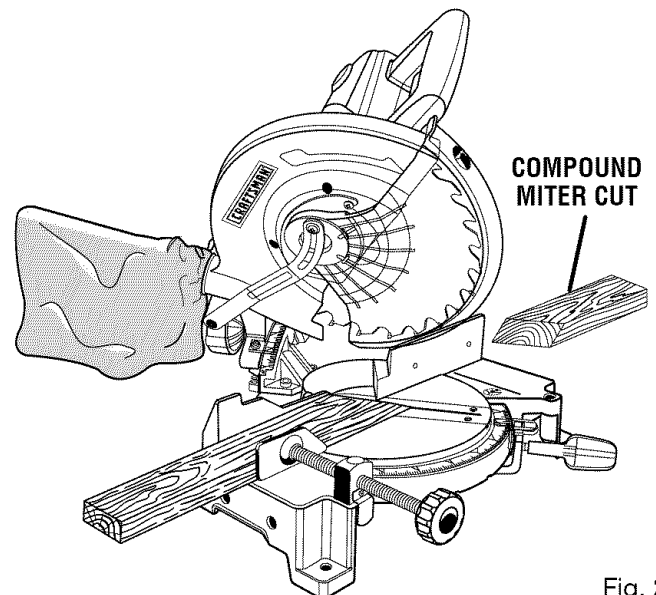

Fig. 29



# OPERATION

- Slowly lower the blade into and through the workpiece. See Figure 29.
- Release the switch trigger and allow the saw blade to stop rotating before raising the blade out of workpiece. Wait until the electric brake stops blade from turning before removing the workpiece from miter table.

## SUPPORT LONG WORKPIECES

See Figure 31.

Long workpieces need extra supports. Supports should be placed along the workpiece so it does not sag. The support should let the workpiece lay flat on the base of the saw and work table during the cutting operation. Use the optional work clamp or a C-clamp to secure the workpiece.

**⚠ WARNING:** To avoid serious personal injury, always keep your hands outside the no hands zone; at least 3 in. from blade. Never perform any cutting operation freehand (without holding workpiece against the fence). The blade could grab the workpiece if it slips or twists.

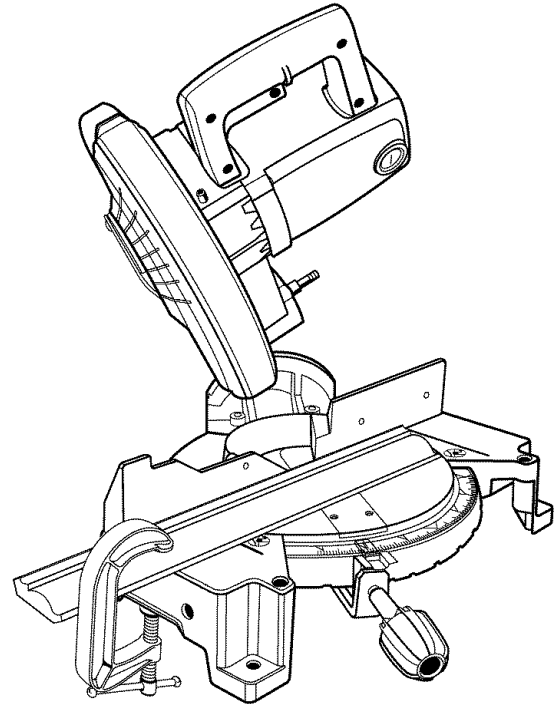

45° X 45° COMPOUND MITER CUT

Fig. 30

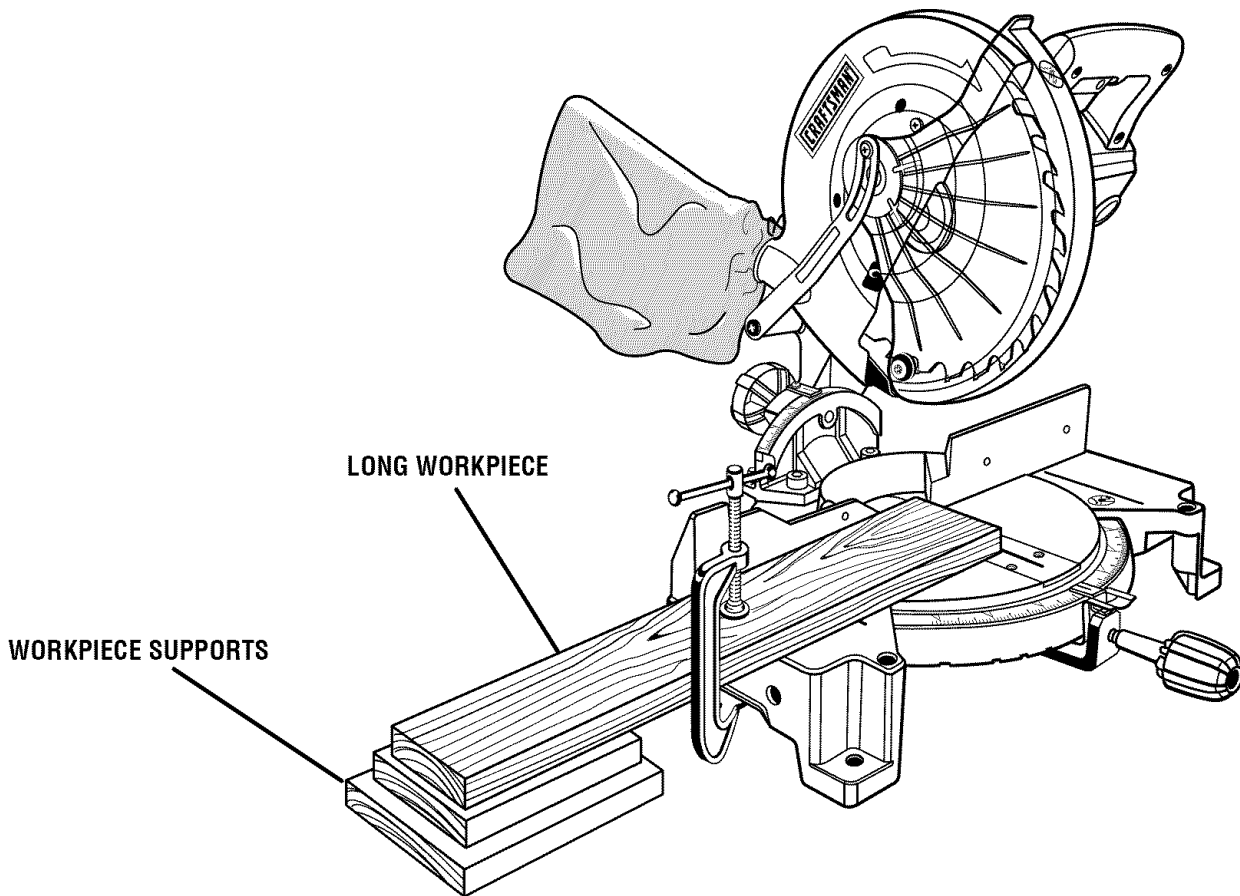

Fig. 31

# OPERATION

## CUTTING COMPOUND MITERS

To aid in making the correct settings, the compound angle setting chart below has been provided. Since compound cuts are the most difficult to accurately obtain, trial cuts should be made in scrap material, and much thought and planning made, prior to making your required cut.

PITCH OF SIDE	NUMBER OF SIDES						
	4	5	6	7	8	9	10
0°	M- 45.00° B- 0.00°	M- 36.00° B- 0.00°	M- 30.00° B- 0.00°	M- 25.71° B- 0.00°	M- 22.50° B- 0.00°	M- 20.00° B- 0.00°	M- 18.00° B- 0.00°
5°	M- 44.89° B- 3.53°	M- 35.90° B- 2.94°	M- 29.91° B- 2.50°	M- 25.63° B- 2.17°	M- 22.42° B- 1.91°	M- 19.93° B- 1.71°	M- 17.94° B- 1.54°
10°	M- 44.56° B- 7.05°	M- 35.58° B- 5.86°	M- 29.62° B- 4.98°	M- 25.37° B- 4.32°	M- 22.19° B- 3.81°	M- 19.72° B- 3.40°	M- 17.74° B- 3.08°
15°	M- 44.01° B- 10.55°	M- 35.06° B- 8.75°	M- 29.15° B- 7.44°	M- 24.95° B- 6.45°	M- 21.81° B- 5.68°	M- 19.37° B- 5.08°	M- 17.42° B- 4.59°
20°	M- 43.22° B- 14.00°	M- 34.32° B- 11.60°	M- 28.48° B- 9.85°	M- 24.35° B- 8.53°	M- 21.27° B- 7.52°	M- 18.88° B- 6.72°	M- 16.98° B- 6.07°
25°	M- 42.19° B- 17.39°	M- 33.36° B- 14.38°	M- 27.62° B- 12.20°	M- 23.56° B- 10.57°	M- 20.58° B- 9.31°	M- 18.26° B- 8.31°	M- 16.41° B- 7.50°
30°	M- 40.89° B- 20.70°	M- 32.18° B- 17.09°	M- 26.57° B- 14.48°	M- 22.64° B- 12.53°	M- 19.73° B- 11.03°	M- 17.50° B- 9.85°	M- 15.72° B- 8.89°
35°	M- 39.32° B- 23.93°	M- 30.76° B- 19.70°	M- 25.31° B- 16.67°	M- 21.53° B- 14.41°	M- 18.74° B- 12.68°	M- 16.60° B- 11.31°	M- 14.90° B- 10.21°
40°	M- 37.45° B- 27.03°	M- 29.10° B- 22.20°	M- 23.86° B- 18.75°	M- 20.25° B- 16.19°	M- 17.60° B- 14.24°	M- 15.58° B- 12.70°	M- 13.98° B- 11.46°
45°	M- 35.26° B- 30.00°	M- 27.19° B- 24.56°	M- 22.21° B- 20.70°	M- 18.80° B- 17.87°	M- 16.32° B- 15.70°	M- 14.43° B- 14.00°	M- 12.94° B- 12.62°
50°	M- 32.73° B- 32.80°	M- 25.03° B- 26.76°	M- 20.36° B- 22.52°	M- 17.20° B- 19.41°	M- 14.91° B- 17.05°	M- 13.17° B- 15.19°	M- 11.80° B- 13.69°
55°	M- 29.84° B- 35.40°	M- 22.62° B- 28.78°	M- 18.32° B- 24.18°	M- 15.44° B- 20.82°	M- 13.36° B- 18.27°	M- 11.79° B- 16.27°	M- 10.56° B- 14.66°
60°	M- 26.57° B- 37.76°	M- 19.96° B- 30.60°	M- 16.10° B- 25.66°	M- 13.54° B- 22.07°	M- 11.70° B- 19.35°	M- 10.31° B- 17.23°	M- 9.23° B- 15.52°
65°	M- 22.91° B- 39.86°	M- 17.07° B- 32.19°	M- 13.71° B- 26.95°	M- 11.50° B- 23.16°	M- 9.93° B- 20.29°	M- 8.74° B- 18.06°	M- 7.82° B- 16.26°
70°	M- 18.88° B- 41.64°	M- 13.95° B- 33.53°	M- 11.17° B- 28.02°	M- 9.35° B- 24.06°	M- 8.06° B- 21.08°	M- 7.10° B- 18.75°	M- 6.34° B- 16.88°
75°	M- 14.51° B- 43.08°	M- 10.65° B- 34.59°	M- 8.50° B- 28.88°	M- 7.10° B- 24.78°	M- 6.12° B- 21.69°	M- 5.38° B- 19.29°	M- 4.81° B- 17.37°
80°	M- 9.85° B- 44.14°	M- 7.19° B- 35.37°	M- 5.73° B- 29.50°	M- 4.78° B- 25.30°	M- 4.11° B- 22.14°	M- 3.62° B- 19.68°	M- 3.23° B- 17.72°
85°	M- 4.98° B- 44.78°	M- 3.62° B- 35.84°	M- 2.88° B- 29.87°	M- 2.40° B- 25.61°	M- 2.07° B- 22.41°	M- 1.82° B- 19.92°	M- 1.62° B- 17.93°
90°	M- 0.00° B- 45.00°	M- 0.00° B- 36.00°	M- 0.00° B- 30.00°	M- 0.00° B- 25.71°	M- 0.00° B- 22.50°	M- 0.00° B- 20.00°	M- 0.00° B- 18.00°

Each B (Bevel) and M (Miter) Setting is Given to the Closest 0.005°.

### COMPOUND-ANGLE SETTINGS FOR POPULAR STRUCTURES

# OPERATION

## CUTTING CROWN MOLDING

Your compound miter saw does an excellent job of cutting crown molding. In general, compound miter saws do a better job of cutting crown molding than any other tool made.

In order to fit properly, crown molding must be compound mitered with extreme accuracy.

The two contact surfaces on a piece of crown molding that fit flat against the ceiling and the wall of a room are at angles that, when added together, equal exactly  $90^\circ$ . Most crown molding has a top rear angle (the section that fits flat against the ceiling) of  $52^\circ$  and a bottom rear angle (the section that fits flat against the wall) of  $38^\circ$ .

## LAYING MOLDING FLAT ON THE MITER TABLE

See Figure 32.

To use this method for accurately cutting crown molding for a  $90^\circ$  inside or outside corner, lay the molding with its broad back surface flat on the miter table and against the fence.

When setting the bevel and miter angles for compound miters, remember that the settings are interdependent; changing one angle changes the other angle as well.

Keep in mind that the angles for crown moldings are very precise and difficult to set. Since it is very easy for these angles to shift, all settings should first be tested on scrap molding. Also most walls do not have angles of exactly  $90^\circ$ , therefore, you will need to fine tune your settings.

When cutting crown molding by this method the bevel angle should be set at  $33.85^\circ$ . The miter angle should be set at  $31.62^\circ$  either right or left, depending on the desired cut for the application. See the chart below for correct angle settings and correct positioning of crown molding on miter table.

The settings in the chart below can be used for cutting All Standard (U.S.) crown molding with  $52^\circ$  and  $38^\circ$  angles. The crown molding is placed flat on the miter table using the compound features of your miter saw.

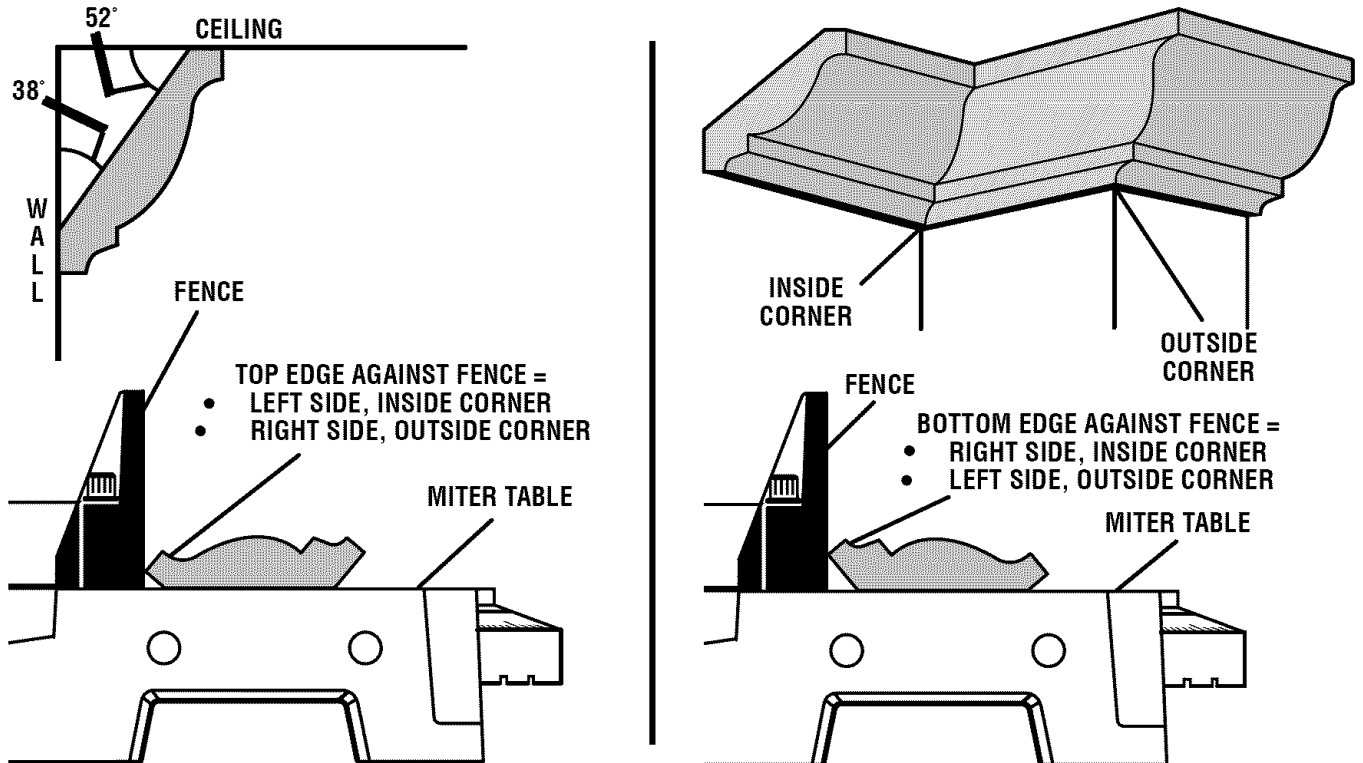

CROWN MOLDING FLAT ON MITER TABLE

Fig. 32

# OPERATION

Bevel Angle Setting	Type of Cut
33.85°	<b>Left side, inside corner</b> 1. Top edge of molding against fence 2. Miter table set right 31.62° 3. Save left end of cut
33.85°	<b>Right side, inside corner</b> 1. Bottom edge of molding against fence 2. Miter table set left 31.62° 3. Save left end of cut
33.85°	<b>Left side, outside corner</b> 1. Bottom edge of molding against fence 2. Miter table set left 31.62° 3. Save right end of cut
33.85°	<b>Right side, outside corner</b> 1. Top edge of molding against fence 2. Miter table set right 31.62° 3. Save right end of cut

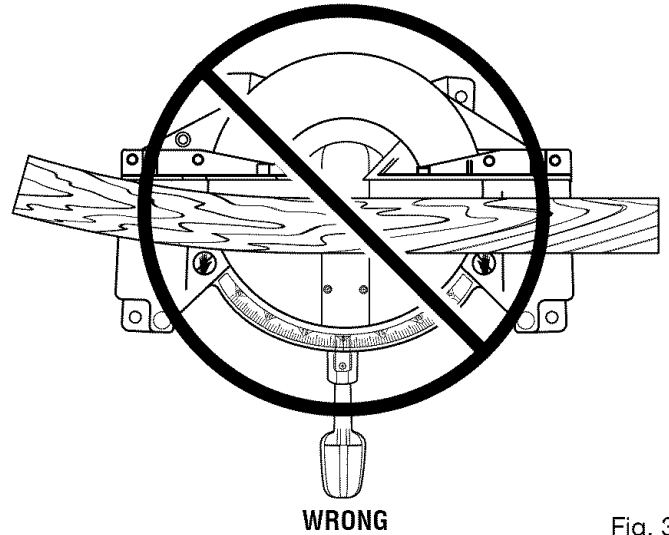

Fig. 34

**WARNING:** To avoid a kickback and to avoid serious personal injury, never position the concave edge of bowed or warped material against the fence.

## CUTTING WARPED MATERIAL

See Figures 33 and 34.

When cutting warped material, always make sure it is positioned on the miter table with the convex side against the fence as shown in figure 33.

If the warped material is positioned the wrong way as shown in figure 34, it will pinch the blade near the completion of the cut.

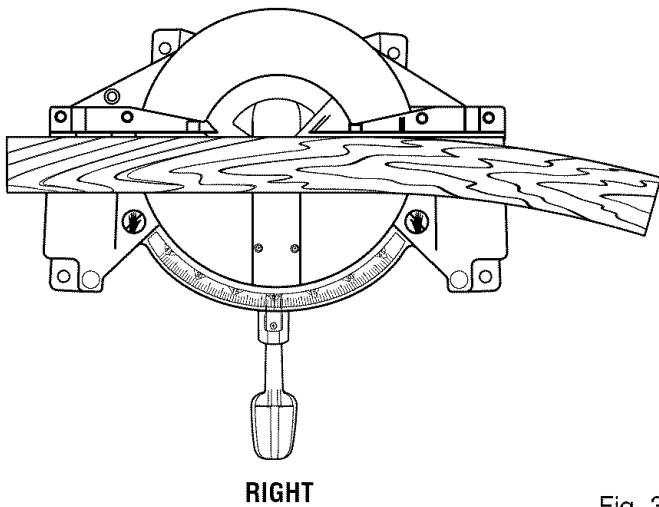

Fig. 33

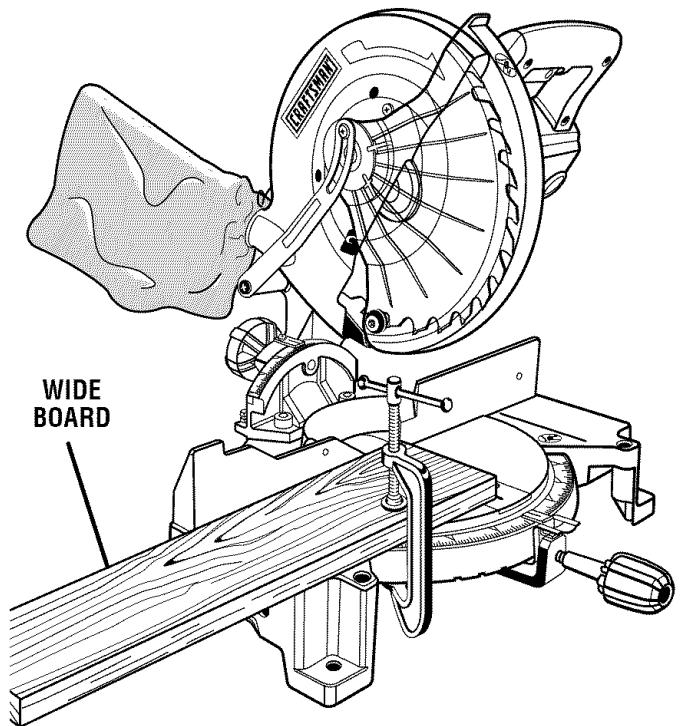

Fig. 35

# ADJUSTMENTS

**⚠ WARNING:** Before performing any adjustment, make sure the tool is unplugged from the power supply and the switch is in the OFF (I) position. Failure to heed this warning could result in serious personal injury.

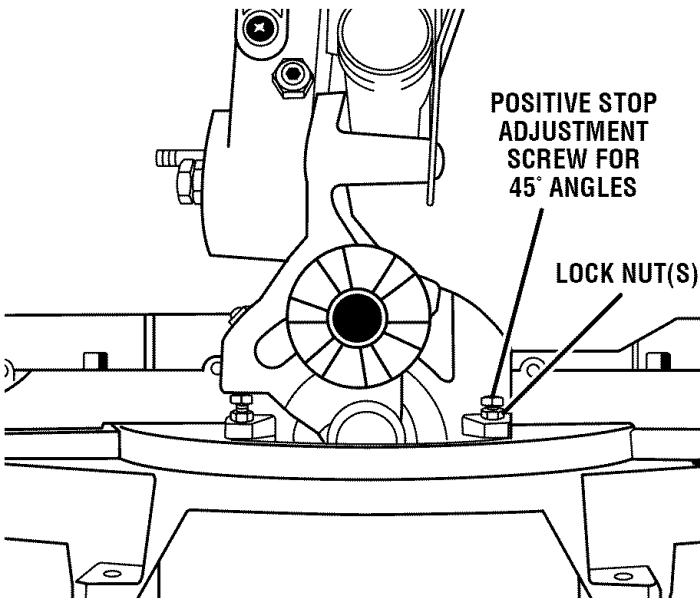

Fig. 36

## PIVOT ADJUSTMENTS

**NOTE:** These adjustments were made at the factory and normally do not require readjustment.

### TRAVEL PIVOT ADJUSTMENT

- The saw arm should rise completely to the up position by itself.
- If the saw arm does not raise by itself or if there is play in the pivot joints, have saw repaired by a qualified service technician at your nearest Sears store or repair center to avoid risk of personal injury.

## BEVEL PIVOT ADJUSTMENT

- Your compound miter saw should bevel easily by loosening the bevel lock knob and tilting the saw arm to the left.
- If movement is tight or if there is play in the pivot, have saw repaired by a qualified service technician at your nearest Sears store or repair center to avoid risk of personal injury.

## DEPTH STOP

See Figure 37.

The depth stop limits the blade's downward travel. It allows the blade to go below the miter table enough to maintain full cutting capacities. The depth stop positions the blade 1/4 in. from the miter table support.

**NOTE:** The miter table support is located inside miter table.

The depth stop is factory set to provide maximum cutting capacity for the 10 in. saw blade provided with your saw. Therefore, the saw blade provided should never need adjustments.

However, when the diameter of the blade has been reduced due to sharpening, it may be necessary to adjust the depth stop to provide maximum cutting capacity. Also, when a new blade is installed, it is necessary to check the clearance of the blade to the miter table support before starting the saw. Make adjustments if needed.

# ADJUSTMENTS

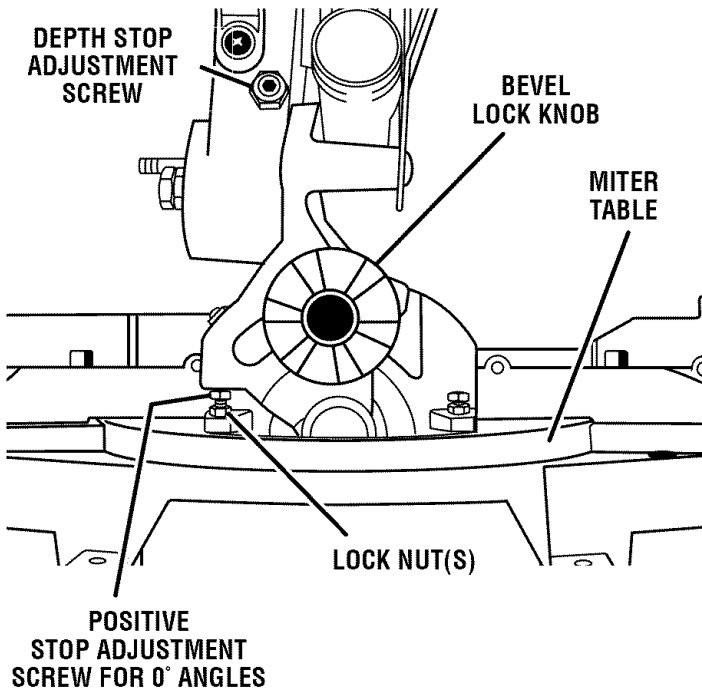

Fig. 37

- Use a 5 mm hex key wrench to adjust the depth stop adjustment screw. The saw blade is lowered by turning the screw counter-clockwise and raised by turning the screw clockwise.
- Lower the blade into the zero clearance throat plate of the miter table. Check blade clearance and maximum cutting distance (distance from fence where blade enters) to front of miter table slot.
- Readjust if necessary.
- Tighten the hex nut with a 17 mm wrench or adjustable wrench.
- To prevent the depth stop adjustment screw from turning while tightening the hex nut, carefully hold it with the hex key wrench while tightening the hex nut.

**⚠ WARNING:** Do not start your compound miter saw without checking for interference between the blade and the miter table support. Damage could result to the blade if it strikes the miter table support during operation of the saw.

## DEPTH STOP ADJUSTMENTS

See Figure 37.

- Unplug your saw.

**⚠ WARNING:** Failure to unplug your saw could result in accidental starting causing possible serious personal injury.

- To adjust the depth stop use a 17 mm wrench or adjustable wrench and loosen the hex nut at the rear of the miter saw arm.

# MAINTENANCE

**WARNING:** When servicing, use only identical Craftsman replacement parts. Use of any other part may create a hazard or cause product damage.

**WARNING:** Always wear safety goggles or safety glasses with side shields during power tool operation or when blowing dust. If operation is dusty, also wear a dust mask.

## GENERAL

Avoid using solvents when cleaning plastic parts. Most plastics are susceptible to damage from various types of commercial solvents and may be damaged by their use. Use clean cloths to remove dirt, carbon dust, etc.

**WARNING:** Do not at any time let brake fluids, gasoline, petroleum-based products, penetrating oils, etc. come in contact with plastic parts. Chemicals can damage, weaken or destroy plastic which may result in serious personal injury.

It has been found that electric tools are subject to accelerated wear and possible premature failure when they are used on fiberglass boats, sports cars, wallboard, spackling compounds, or plaster. The chips and grindings from these materials are highly abrasive to electric tool parts such as bearings, brushes, commutators, etc. Consequently, it is not recommended that this tool be used for extended work on any fiberglass material, wallboard, spackling compounds, or plaster. During any use on these materials it is extremely important that the tool is cleaned frequently by blowing with an air jet.

## LUBRICATION

All of the bearings in this tool are lubricated with a sufficient amount of high grade lubricant for the life of the unit under normal operating conditions. Therefore, no further lubrication is required.

**WARNING:** To ensure safety and reliability, all repairs — with the exception of the externally accessible brushes — should be performed by a qualified service technician at a Sears store to avoid risk of personal injury.

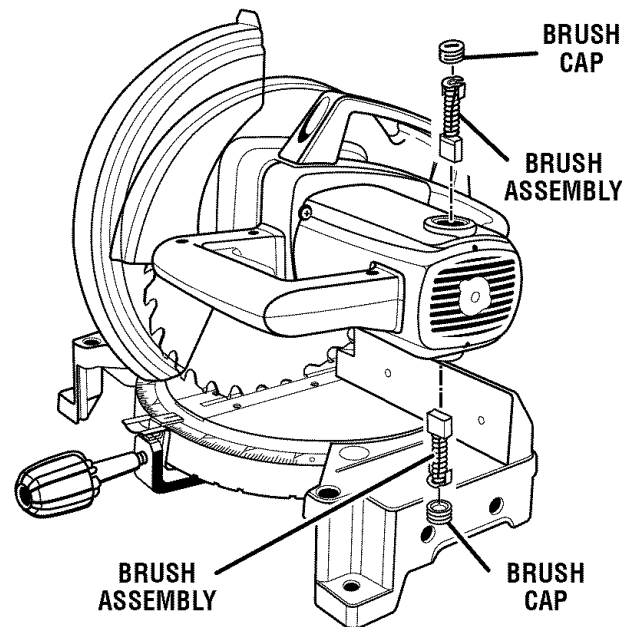

Fig. 38

## BRUSH REPLACEMENT

See Figure 38.

Your saw has externally accessible brush assemblies that should be periodically checked for wear.

**Proceed as follows when replacement is required:**

- Unplug your saw.

- ▲ **WARNING:** Failure to unplug your saw could result in accidental starting causing serious injury.
- Remove brush cap with a screwdriver. Brush assembly is spring loaded and will pop out when you remove brush cap.
- Remove brush assembly.
- Check for wear. Replace both brushes when either has less than 1/4 in. length of carbon remaining. **Do not** replace one side without replacing the other.
- Reassemble using new brush assemblies. Make sure curvature of brush matches curvature of motor and that brush moves freely in brush tube.
- Make sure brush cap is oriented correctly (straight) and replace.
- Tighten brush cap securely. **Do not** overtighten.

FIGURE A

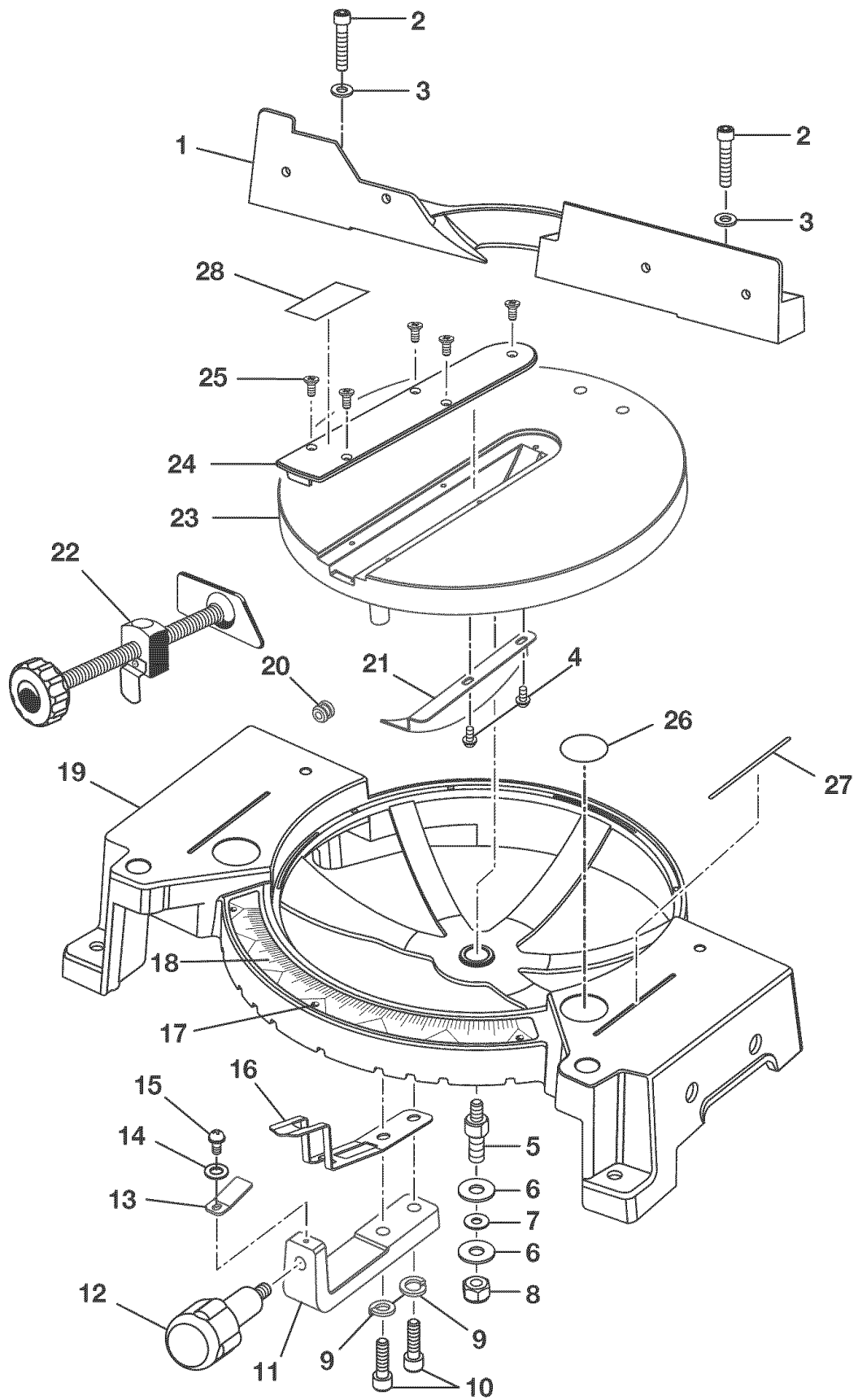



## CRAFTSMAN COMPOUND MITER SAW – MODEL NUMBER 315.212040

The model number will be found on a plate attached to the motor housing. Always mention the model number in all correspondence regarding your **Compound Miter Saw** or when ordering repair parts.

### PARTS LIST - FIGURE A

Key No.	Part Number	Description	Qty.
	S51100300	Base and Table Assembly	
1	511106000	Fence.....	1
2	A07103080457	* Socket Head Cap Screw (M8 x 45 mm).....	4
3	A36030814204	* Lock Washer (M8).....	4
4	A19003040093	* Screw (M4 x 9 mm Pan Hd.).....	2
5	518106300	Table Spindle.....	1
6	A35031025153	* Flat Washer (M10).....	2
7	A36131020100	* Lock Washer (M10).....	1
8	A31703010008	* Lock Nut (M10).....	1
9	A36030612157	* Spring Washer (M6).....	2
10	A07003060257	* Socket Head Cap Screw (M6 x 25 mm Pan Hd.).....	2
11	518104200	Control Arm.....	1
12	511107000	Lock Handle.....	1
13	580114000	Pointer.....	1
14	A35030410018	* Flat Washer (M4).....	1
15	A10003040107	* Screw (M4 x 10 mm Pan Hd.).....	1
16	518105400	Lock Plate.....	1
17	A49001020056	Rivet.....	3
18	511108000	Miter Scale.....	1
19	511105000	Base.....	1
20	580120000	Fixed Cap (Grommet).....	1
21	511104000	Table Hold Down.....	1
22	518A08130	Vise Clamp Assembly.....	1
23	512106000	Table.....	1
24	589027202	Throat Plate.....	1
25	A16003040083	* Screw (M4 x 8 mm Flat Hd.).....	4
26	588072000	No Hands Label.....	2
27	588071004	Line Warning Label.....	2
28	511109000	Insert Plate Label.....	1

\* Standard Hardware Item – May Be Purchased Locally

FIGURE B

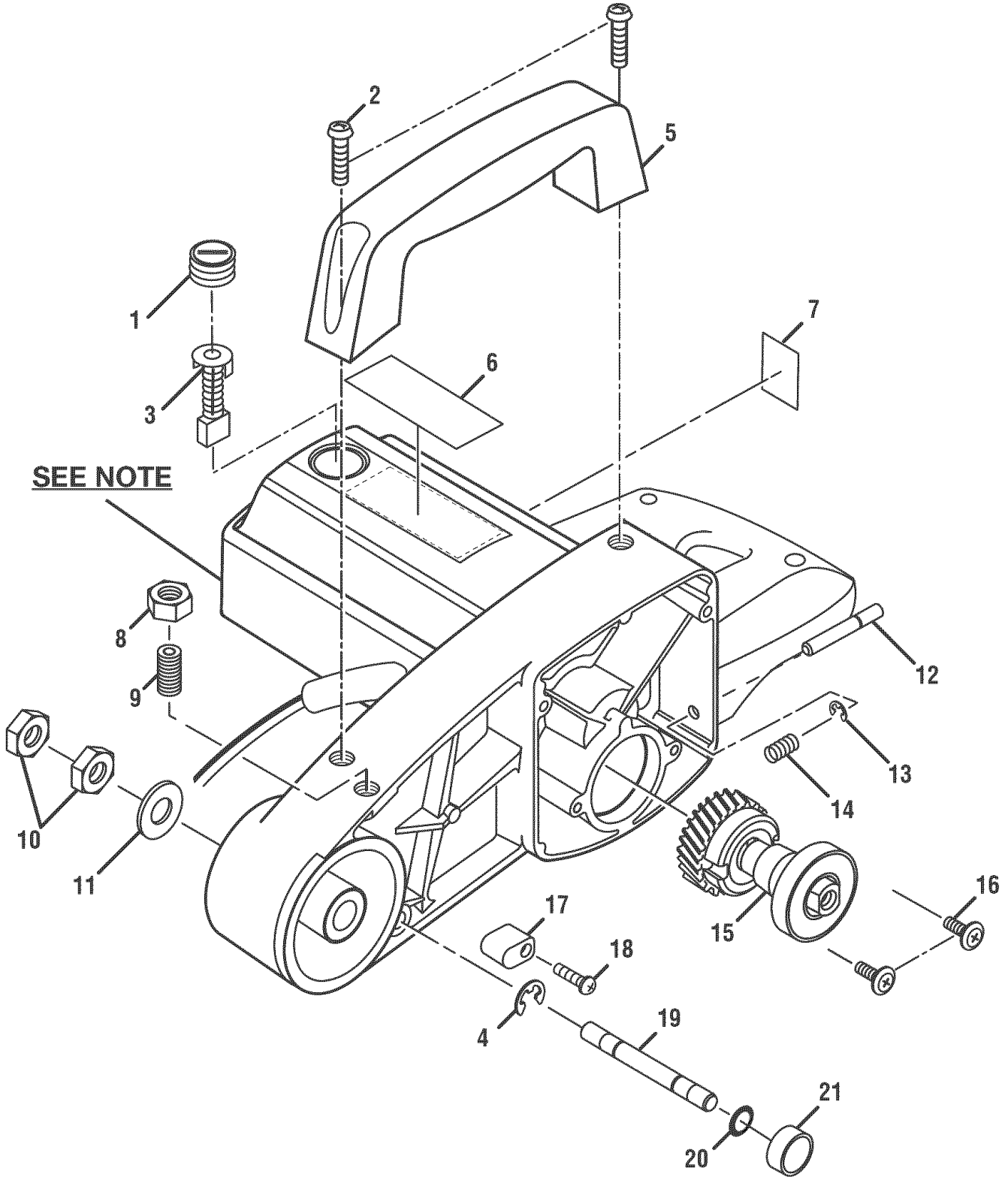

**SEE NOTE**

**NOTE :** The assembly shown represents an important part of the double insulated system. To avoid the possibility of alteration or damage to the system, service should be performed by your nearest Sears Repair Center. Contact your nearest Sears retail store for service center information.

**CRAFTSMAN COMPOUND MITER SAW – MODEL NUMBER 315.212040**

The model number will be found on a plate attached to the motor housing. Always mention the model number in all correspondence regarding your **Compound Miter Saw** or when ordering repair parts.

**PARTS LIST - FIGURE B**

<b>Key No.</b>	<b>Part Number</b>	<b>Description</b>	<b>Qty.</b>
1	528311004	Brush Cap.....	2
2	A10003060160	* Screw (M6 x 16 mm Pan Hd.).....	2
3	588006100	Brush Assembly.....	2
4	A47000060002	E-Ring.....	1
5	511328000	Carry Handle.....	1
6	578310008	Warning Label.....	1
7	511329000	Data Plate.....	1
8	A30003010007	* Hex Nut (M10).....	1
9	A18003100206	* Set Screw (M10 x 20 mm).....	1
10	A30003012194	* Hex Nut (M12).....	2
11	A36031226023	* Flat Washer (M12).....	1
12	588026106	Spindle Lock Pin.....	1
13	A47000040006	E-Ring.....	1
14	588027005	Compression Spring.....	1
15	511X03040	Arbor Assembly.....	1
16	588031004	* Special Screw (M5 x 10 mm).....	2
17	588021203	Rubber Sleeve.....	1
18	A90003040167	* Screw (M4 x 16 mm Pan Hd.).....	1
19	588022300	Stop Pin.....	1
20	A63000000051	O-Ring.....	1
21	588023001	Stop Pin Cap.....	1

\* Standard Hardware Item – May Be Purchased Locally

FIGURE C

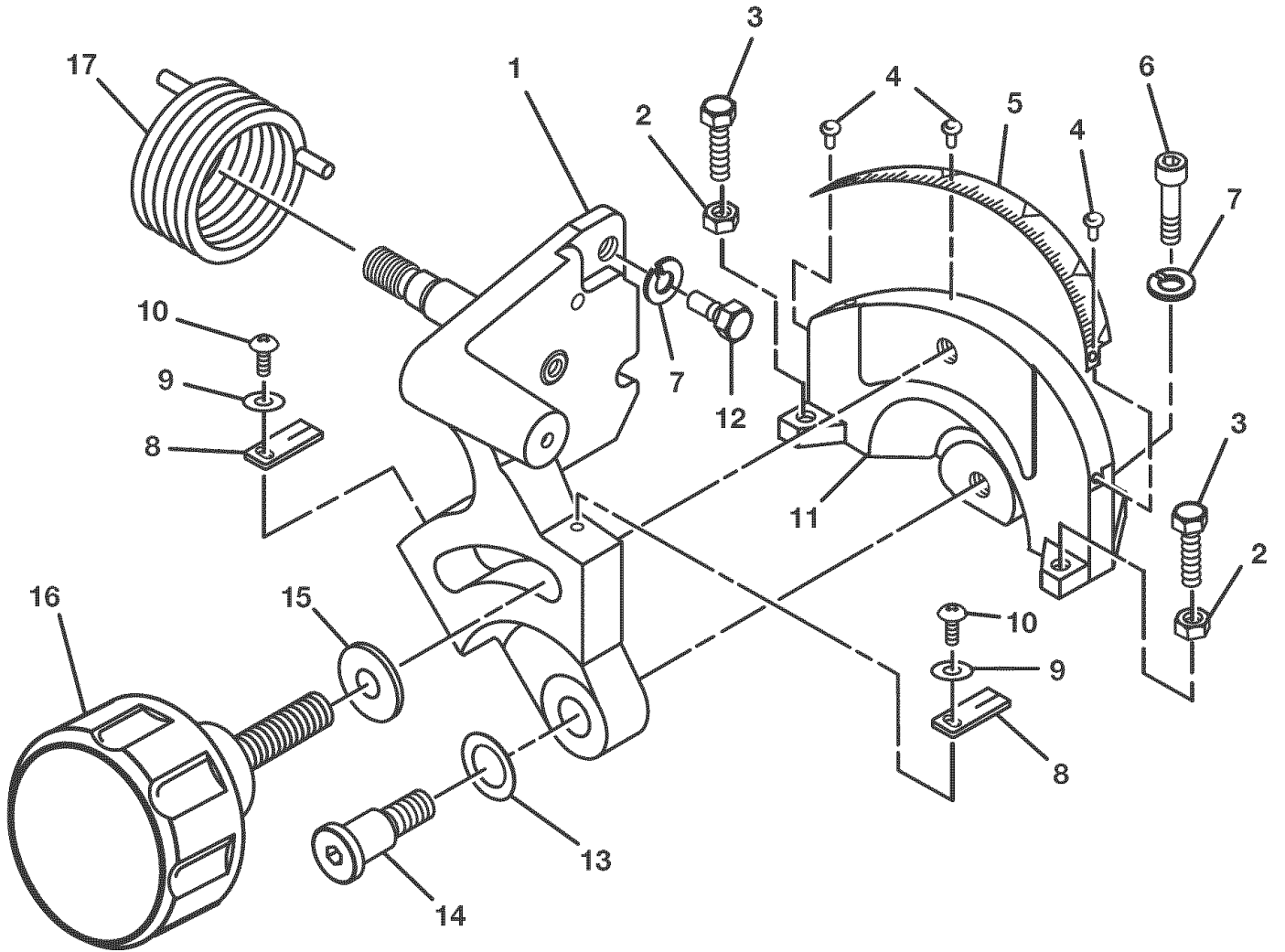

## CRAFTSMAN COMPOUND MITER SAW – MODEL NUMBER 315.212040

The model number will be found on a plate attached to the motor housing. Always mention the model number in all correspondence regarding your **Compound Miter Saw** or when ordering repair parts.

### PARTS LIST - FIGURE C

Key No.	Part Number	Description	Qty.
1	511D04020	Support Bracket Assembly.....	1
2	A30003006003	* Hex Nut (M6).....	2
3	578206000	* Hex Bolt (M6 x 16 mm).....	2
4	A49001020056	Rivet.....	3
5	511203000	Bevel Scale.....	1
6	A07003100256	* Socket Head Cap Screw (M10 x 25 mm).....	2
7	A36031018255	* Lock Washer (M10).....	3
8	578203007	Pointer.....	2
9	A35030410018	* Flat Washer (M4).....	2
10	A10003040107	* Screw (M4 x 10 mm Pan Hd.).....	2
11	578205106	Pivot Support.....	1
12	588058103	Lock Bolt.....	1
13	589011308	Washer.....	1
14	589010200	Pivot Shaft.....	1
15	A35031025153	* Flat Washer (M10).....	1
16	511202000	Bevel Lock Knob.....	1
17	580319000	Tension Spring.....	1
	983000-471	Operator's Manual	

\* Standard Hardware Item – May Be Purchased Locally

PARTS LIST - FIGURE D

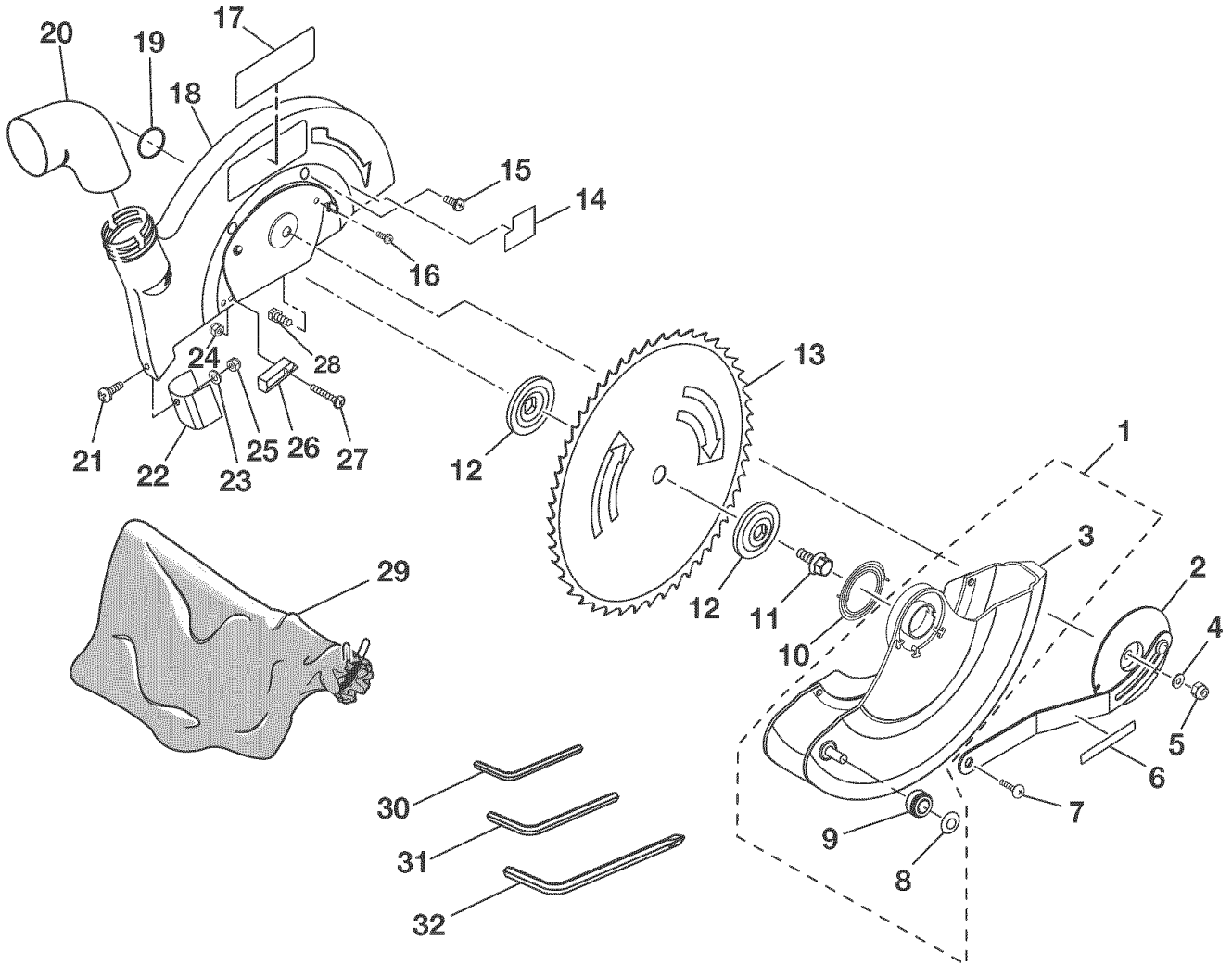

## CRAFTSMAN COMPOUND MITER SAW – MODEL NUMBER 315.212040

The model number will be found on a plate attached to the motor housing. Always mention the model number in all correspondence regarding your **Compound Miter Saw** or when ordering repair parts.

### PARTS LIST - FIGURE D

Key No.	Part Number	Description	Qty.
1	S51100200	Lower Guard Assembly .....	1
2	511D06010	Retaining Spring Holder .....	1
3	511406000	Lower Guard .....	1
4	A35010616105	* Flat Washer (M6).....	1
5	A31703006004	* Lock Nut (M6) .....	1
6	976740-001	Label .....	1
7	589015108	Shoulder Screw .....	1
8	538417000	Retaining Ring .....	1
9	566407000	Roller .....	1
10	589021300	Retract Spring .....	1
11	580412000	Hex Washer Hand Screw.....	1
12	588035105	Flange .....	2
13	511512000	Blade .....	1
14	555412000	Cover Label .....	1
15	A10003050106	* Screw (M5 x 10 mm Pan Hd.).....	4
16	A19001040091	* Screw (M4 x 9 mm Pan Hd.).....	1
17	595015001	Logo Plate .....	1
18	S51100100	Upper Guard Assembly .....	1
19	A63020000428	O-Ring .....	1
20	595026002	Elbow .....	1
21	A10003050105	* Screw (M5 x 10 mm Pan Hd.).....	1
22	589034005	Deflector .....	1
23	A35030519105	* Flat Washer (M5).....	1
24	A31703004006	* Lock Nut (M4) .....	1
25	A31703005005	* Lock Nut (M5) .....	1
26	589032207	Stopper.....	1
27	A10003040152	* Screw (M4 x 15 mm Pan Hd.).....	1
28	581410003	Screw.....	1
29	511516000	Dust Bag.....	1
30	A07910520000	* Hex Key (5 mm) .....	1
31	A07810622000	* Blade Wrench (6 mm) .....	1
32	A07910820000	* Hex Key (8 mm) .....	1

\* Standard Hardware Item – May Be Purchased Locally

# Get it fixed, at your home or ours!

## Your Home

For repair – **in your home** – of **all** major brand appliances, lawn and garden equipment, or heating and cooling systems, **no matter who made it, no matter who sold it!**

For the replacement parts, accessories and owner's manuals that you need to do-it-yourself.

For Sears professional installation of home appliances and items like garage door openers and water heaters.

**1-800-4-MY-HOME®** (1-800-469-4663)

Call anytime, day or night (U.S.A. and Canada)

[www.sears.com](http://www.sears.com)      [www.sears.ca](http://www.sears.ca)

---

## Our Home

For repair of carry-in items like vacuums, lawn equipment, and electronics, call or go on-line for the location of your nearest **Sears Parts & Repair Center.**

**1-800-488-1222**

Call anytime, day or night (U.S.A. only)

[www.sears.com](http://www.sears.com)

---

To purchase a protection agreement (U.S.A.) or maintenance agreement (Canada) on a product serviced by Sears:

**1-800-827-6655** (U.S.A.)

**1-800-361-6665** (Canada)

---

Para pedir servicio de reparación a domicilio, y para ordenar piezas:

**1-888-SU-HOGAR<sup>SM</sup>**  
(1-888-784-6427)

Au Canada pour service en français:

**1-800-LE-FOYER<sup>MC</sup>**  
(1-800-533-6937)  
[www.sears.ca](http://www.sears.ca)

# SEARS



## Free Manuals Download Website

<http://myh66.com>

<http://usermanuals.us>

<http://www.somanuals.com>

<http://www.4manuals.cc>

<http://www.manual-lib.com>

<http://www.404manual.com>

<http://www.luxmanual.com>

<http://aubethermostatmanual.com>

Golf course search by state

<http://golfingnear.com>

Email search by domain

<http://emailbydomain.com>

Auto manuals search

<http://auto.somanuals.com>

TV manuals search

<http://tv.somanuals.com>