

# OPERATOR'S MANUAL

# CRAFTSMAN<sup>®</sup>

## 18 in. SCROLL SAW VARIABLE SPEED

Model No.  
315.216090

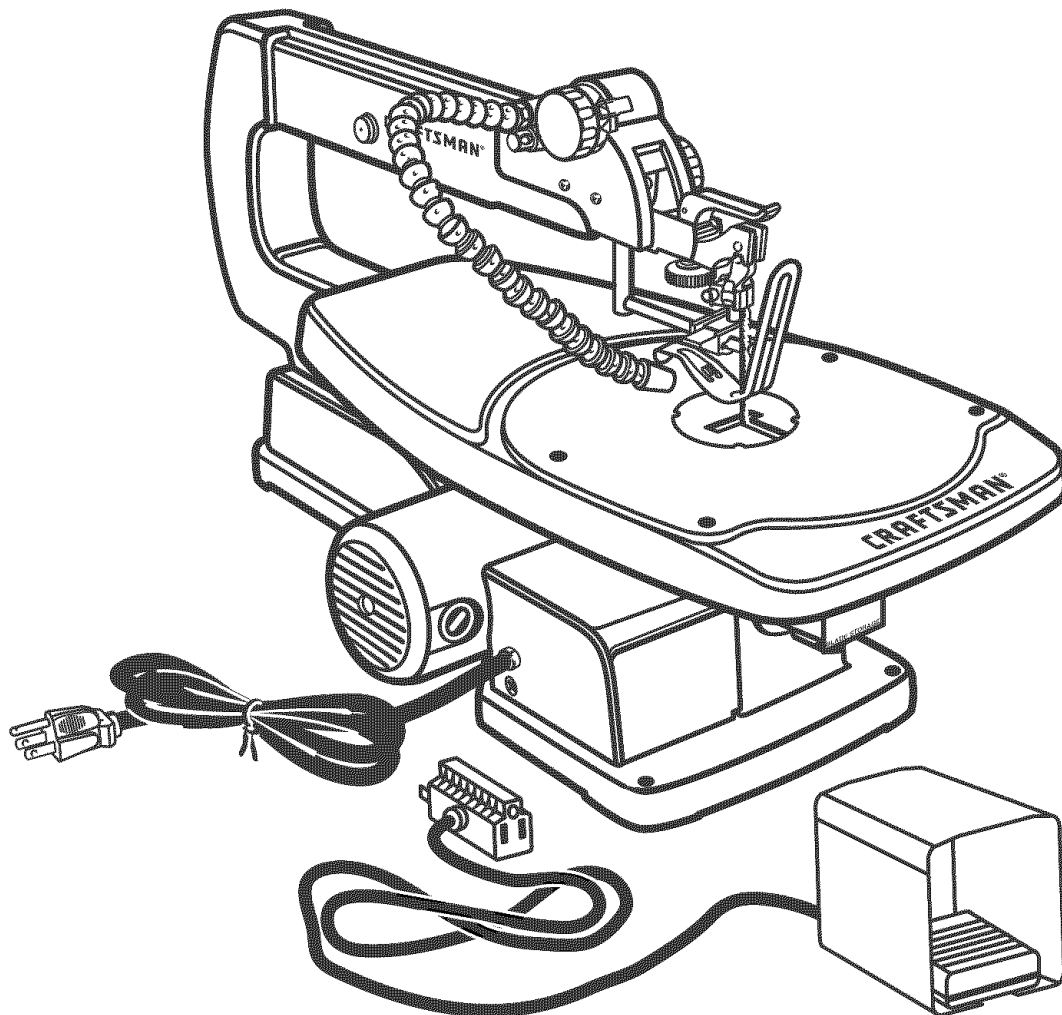

**⚠ WARNING:** To reduce the risk of injury, the user must read and understand the operator's manual before using this product.

Customer Help Line: 1-800-932-3188

Sears, Roebuck and Co., 3333 Beverly Rd., Hoffman Estates, IL 60179 USA  
Visit the Craftsman web page: [www.sears.com/craftsman](http://www.sears.com/craftsman)

983000-769  
08-05

**Save this manual for future reference**



# TABLE OF CONTENTS

■ Warranty .....	2
■ Introduction .....	2
■ General Safety Rules .....	3-4
■ Specific Safety Rules.....	5
■ Symbols.....	6-7
■ Electrical.....	8
■ Glossary of Terms.....	9
■ Features.....	10-11
■ Tools Needed .....	12
■ Loose Parts .....	12
■ Assembly.....	13-15
■ Operation.....	15-19
■ Adjustments.....	20
■ Maintenance.....	20-21
■ Troubleshooting.....	22
■ Notes .....	23
■ Exploded View and Parts List.....	24-27
■ Parts Ordering/Service .....	Back Page

# WARRANTY

## ONE YEAR FULL WARRANTY ON CRAFTSMAN TOOL

If this Craftsman tool fails due to a defect in material or workmanship within one year from the date of purchase, **CONTACT THE NEAREST SEARS PARTS & REPAIR CENTER at 1-800-4-MY-HOME®** and Sears will repair it, free of charge. This warranty applies only while this product is in the United States.

If this tool is used for commercial or rental purposes, this warranty will apply for only ninety days from the date of purchase.

This warranty gives you specific legal rights, and you may also have other rights which vary from state to state.

**Sears, Roebuck and Co., Dept. 817WA, Hoffman Estates, IL 60179**

# INTRODUCTION

This tool has many features for making its use more pleasant and enjoyable. Safety, performance, and dependability have been given top priority in the design of this product making it easy to maintain and operate.

# GENERAL SAFETY RULES

**⚠ WARNING: Read and understand all instructions.** Failure to follow all instructions listed below may result in electric shock, fire, and/or serious personal injury.

## READ ALL INSTRUCTIONS

- **KNOW YOUR POWER TOOL.** Read the operator's manual carefully. Learn the applications and limitations as well as the specific potential hazards related to this tool.
- **GUARD AGAINST ELECTRICAL SHOCK BY PREVENTING BODY CONTACT WITH GROUNDED SURFACES.** For example: pipes, radiators, ranges, refrigerator enclosures.
- **KEEP GUARDS IN PLACE** and in good working order.
- **REMOVE ADJUSTING KEYS AND WRENCHES.** Form the habit of checking to see that keys and adjusting wrenches are removed from tool before turning it on.
- **KEEP WORK AREA CLEAN.** Cluttered areas and benches invite accidents. **DO NOT** leave tools or pieces of wood on the tool while it is in operation.
- **DO NOT USE IN DANGEROUS ENVIRONMENTS.** Do not use power tools in damp or wet locations or expose to rain. Keep the work area well lit.
- **KEEP CHILDREN AND VISITORS AWAY.** All visitors should wear safety glasses and be kept a safe distance from work area. Do not let visitors contact tool or extension cord while operating.
- **MAKE WORKSHOP CHILDPROOF** with padlocks, master switches, or by removing starter keys.
- **DON'T FORCE THE TOOL.** It will do the job better and safer at the feed rate for which it was designed.
- **USE THE RIGHT TOOL.** Do not force the tool or attachment to do a job for which it was not designed.
- **USE THE PROPER EXTENSION CORD.** Make sure the extension cord is in good condition. Use only a cord heavy enough to carry the current the product will draw. An undersized cord will cause a drop in line voltage resulting in loss of power and overheating. A wire gauge size (A.W.G.) of at least **16** is recommended for an extension cord 25 feet or less in length. If in doubt, use the next heavier gauge. The smaller the gauge number, the heavier the cord.
- **DRESS PROPERLY.** Do not wear loose clothing, neckties, or jewelry that can get caught and draw you into moving parts. Rubber gloves and nonskid footwear are recommended when working outdoors. Also wear protective hair covering to contain long hair.
- **ALWAYS WEAR SAFETY GLASSES WITH SIDE SHIELDS.** Everyday eyeglasses have only impact-resistant lenses, they are **NOT** safety glasses.
- **SECURE WORK.** Use clamps or a vise to hold work when practical, it is safer than using your hand and frees both hands to operate the tool.
- **DO NOT OVERREACH.** Keep proper footing and balance at all times.
- **MAINTAIN TOOLS WITH CARE.** Keep tools sharp and clean for better and safer performance. Follow instructions for lubricating and changing accessories.
- **DISCONNECT TOOLS.** When not in use, before servicing, or when changing attachments, blades, bits, cutters, etc., all tools should be disconnected from power source.
- **AVOID ACCIDENTAL STARTING.** Be sure switch is off when plugging in any tool.
- **USE RECOMMENDED ACCESSORIES.** Consult the operator's manual for recommended accessories. The use of improper accessories may result in injury.
- **NEVER STAND ON TOOL.** Serious injury could occur if the tool is tipped.
- **CHECK DAMAGED PARTS.** Before further use of the tool, a guard or other part that is damaged should be carefully checked to determine that it will operate properly and perform its intended function. Check for alignment of moving parts, binding of moving parts, breakage of parts, mounting and any other conditions that may affect its operation. A guard or other part that is damaged must be properly repaired or replaced by an authorized service center to avoid risk of personal injury.
- **USE THE RIGHT DIRECTION OF FEED.** Feed work into a blade, cutter, or sanding spindle against the direction or rotation of the blade, cutter, or sanding spindle only.
- **NEVER LEAVE TOOL RUNNING UNATTENDED. TURN THE POWER OFF.** Don't leave tool until it comes to a complete stop.
- **PROTECT YOUR LUNGS.** Wear a face or dust mask if the cutting operation is dusty.
- **PROTECT YOUR HEARING.** Wear hearing protection during extended periods of operation.
- **DO NOT ABUSE CORD.** Never carry tool by the cord or yank it to disconnect from receptacle. Keep cord from heat, oil, and sharp edges.
- **USE OUTDOOR EXTENSION CORDS.** When tool is used outdoors, use only extension cords with approved ground connection that are intended for use outdoors and so marked.
- **KEEP BLADES CLEAN, SHARP, AND WITH SUFFICIENT SET.** Sharp blades minimize stalling and kickback.
- **BLADE COASTS AFTER BEING TURNED OFF.**

# GENERAL SAFETY RULES

- **NEVER USE IN AN EXPLOSIVE ATMOSPHERE.** Normal sparking of the motor could ignite fumes.
- **INSPECT TOOL CORDS PERIODICALLY.** If damaged, have repaired by a qualified service technician at an authorized service facility. The conductor with insulation having an outer surface that is green with or without yellow stripes is the equipment-grounding conductor. If repair or replacement of the electric cord or plug is necessary, do not connect the equipment-grounding conductor to a live terminal. Repair or replace a damaged or worn cord immediately. Stay constantly aware of cord location and keep it well away from the rotating blade.
- **INSPECT EXTENSION CORDS PERIODICALLY** and replace if damaged.
- **KEEP TOOL DRY, CLEAN, AND FREE FROM OIL AND GREASE.** Always use a clean cloth when cleaning. Never use brake fluids, gasoline, petroleum-based products, or any solvents to clean tool.
- **STAY ALERT AND EXERCISE CONTROL.** Watch what you are doing and use common sense. Do not operate tool when you are tired. Do not rush.
- **DO NOT USE TOOL IF SWITCH DOES NOT TURN IT ON AND OFF.** Have defective switches replaced by an authorized service center.
- **USE ONLY CORRECT BLADES.** Use the right blade size, style, and cutting speed for the material and the type of cut. Blade teeth should point down toward the table.
- **BEFORE MAKING A CUT, BE SURE ALL ADJUSTMENTS ARE SECURE.**
- **BE SURE BLADE PATH IS FREE OF NAILS.** Inspect for and remove all nails from lumber before cutting.
- **NEVER TOUCH BLADE** or other moving parts during use.
- **NEVER START A TOOL WHEN ANY ROTATING COMPONENT IS IN CONTACT WITH THE WORKPIECE.**
- **DO NOT OPERATE A TOOL WHILE UNDER THE INFLUENCE OF DRUGS, ALCOHOL, OR ANY MEDICATION.**
- **WHEN SERVICING** use only identical replacement parts. Use of any other parts may create a hazard or cause product damage.
- **USE ONLY RECOMMENDED ACCESSORIES** listed in this manual or addendums. Use of accessories that are not listed may cause the risk of personal injury. Instructions for safe use of accessories are included with the accessory.
- **DOUBLE CHECK ALL SETUPS.** Make sure blade is tight and not making contact with saw or workpiece before connecting to power supply.

## SPECIFIC SAFETY RULES

- **FIRMLY CLAMP OR BOLT** the tool to a workbench or table at approximately hip height.
- **KEEP HANDS AWAY FROM CUTTING AREA.** Do not reach underneath work or in blade cutting path with your hands and fingers for any reason. Always turn the power off.
- **ALWAYS USE A CLAMP** to secure the workpiece when possible.
- **ALWAYS SUPPORT LONG WORKPIECES** while cutting to minimize risk of blade pinching and kickback. Saw may slip, walk or slide while cutting long or heavy boards.
- **BE SURE THE BLADE CLEARS THE WORKPIECE.** Never start the saw with the blade touching the workpiece. Allow motor to come up to full speed before starting cut.
- **DO NOT FEED THE MATERIAL TOO QUICKLY.** Do not force the workpiece against the blade.
- **NEVER** reach behind, under, or within three inches of the blade and its cutting path with your hands and fingers for any reason.
- **NEVER** reach to pick up a workpiece, a piece of scrap, or anything else that is in or near the cutting path of the blade.
- **AVOID AWKWARD OPERATIONS AND HAND POSITIONS** where a sudden slip could cause your hand to move into the blade. **ALWAYS** make sure you have good balance. **NEVER** operate the saw on the floor or in a crouched position.
- **IF ANY PART OF THIS SAW IS MISSING** or should break, bend, or fail in any way, or should any electrical component fail to perform properly, shut off the power switch, remove the plug from the power source, and have damaged, missing, or failed parts replaced before resuming operation.
- **IF THE POWER SUPPLY CORD IS DAMAGED**, it must be replaced only by the manufacturer or by an authorized service center to avoid risk.
- **ALWAYS STAY ALERT!** Do not allow familiarity (gained from frequent use of the saw) to cause a careless mistake. **ALWAYS REMEMBER** that a careless fraction of a second is sufficient to inflict severe injury.
- **MAKE SURE THE WORK AREA HAS AMPLE LIGHTING** to see the work and that no obstructions will interfere with safe operation **BEFORE** performing any work using the saw.
- **ALWAYS TURN OFF THE SAW** before disconnecting it to avoid accidental starting when reconnecting to power supply. **NEVER** leave the saw unattended while connected to a power source.
- **TURN OFF TOOL** and wait for saw blade to come to a complete stop before moving workpiece or changing settings.
- **SAVE THESE INSTRUCTIONS.** Refer to them frequently and use to instruct other users. If you loan someone this tool, loan them these instructions also.

---











 **WARNING:** Some dust created by power sanding, sawing, grinding, drilling, and other construction activities contains chemicals known to cause cancer, birth defects or other reproductive harm. Some examples of these chemicals are:

- lead from lead-based paints,
- crystalline silica from bricks and cement and other masonry products, and
- arsenic and chromium from chemically-treated lumber.

Your risk from these exposures varies, depending on how often you do this type of work. To reduce your exposure to these chemicals: work in a well ventilated area, and work with approved safety equipment, such as those dust masks that are specially designed to filter out microscopic particles.



# SYMBOLS

Some of the following symbols may be used on this tool. Please study them and learn their meaning. Proper interpretation of these symbols will allow you to operate the tool better and safer.

SYMBOL	NAME	DESIGNATION/EXPLANATION
V	Volts	Voltage
A	Amperes	Current
Hz	Hertz	Frequency (cycles per second)
W	Watt	Power
min	Minutes	Time
~	Alternating Current	Type of current
—	Direct Current	Type or a characteristic of current
$n_0$	No Load Speed	Rotational speed, at no load
	Class II Construction	Double-insulated construction
.../min	Per Minute	Revolutions, strokes, surface speed, orbits etc., per minute
	Wet Conditions Alert	Do not expose to rain or use in damp locations.
	Read The Operator's Manual	To reduce the risk of injury, user must read and understand operator's manual before using this product.
	Eye Protection	Always wear safety goggles or safety glasses with side shields, or a full face shield when operating this product.
	Safety Alert	Precautions that involve your safety.
	No Hands Symbol	Failure to keep your hands away from the blade will result in serious personal injury.
	No Hands Symbol	Failure to keep your hands away from the blade will result in serious personal injury.
	No Hands Symbol	Failure to keep your hands away from the blade will result in serious personal injury.
	No Hands Symbol	Failure to keep your hands away from the blade will result in serious personal injury.
	Hot Surface	To reduce the risk of injury or damage, avoid contact with any hot surface.

# SYMBOLS

The following signal words and meanings are intended to explain the levels of risk associated with this product.

SYMBOL	SIGNAL	MEANING
	<b>DANGER:</b>	Indicates an imminently hazardous situation, which, if not avoided, will result in death or serious injury.
	<b>WARNING:</b>	Indicates a potentially hazardous situation, which, if not avoided, could result in death or serious injury.
	<b>CAUTION:</b>	Indicates a potentially hazardous situation, which, if not avoided, may result in minor or moderate injury.
	<b>CAUTION:</b>	(Without Safety Alert Symbol) Indicates a situation that may result in property damage.

## SERVICE

Servicing requires extreme care and knowledge and should be performed only by a qualified service technician. For service we suggest you return the product to your nearest **AUTHORIZED SERVICE CENTER** for repair. When servicing, use only identical replacement parts.



**WARNING:** To avoid serious personal injury, do not attempt to use this product until you read thoroughly and understand completely the operator's manual. Save this operator's manual and review frequently for continuing safe operation and instructing others who may use this product.



## WARNING:



The operation of any power tool can result in foreign objects being thrown into your eyes, which can result in severe eye damage. Before beginning power tool operation, always wear safety goggles or safety glasses with side shields and a full face shield when needed. We recommend Wide Vision Safety Mask for use over eyeglasses or standard safety glasses with side shields. Always use eye protection which is marked to comply with ANSI Z87.1.

## SAVE THESE INSTRUCTIONS

# ELECTRICAL

## EXTENSION CORDS

Use only 3-wire extension cords that have 3-prong grounding plugs and 3-pole receptacles that accept the tool's plug. When using a power tool at a considerable distance from the power source, use an extension cord heavy enough to carry the current that the tool will draw. An undersized extension cord will cause a drop in line voltage, resulting in a loss of power and causing the motor to overheat. Use the chart provided below to determine the minimum wire size required in an extension cord. Only round jacketed cords listed by Underwriter's Laboratories (UL) should be used.

\*\*Ampere rating (on tool data plate)

Cord Length	Wire Size (A.W.G.)					
	0-2.0	2.1-3.4	3.5-5.0	5.1-7.0	7.1-12.0	12.1-16.0
25'	16	16	16	16	14	14
50'	16	16	16	14	14	12
100'	16	16	14	12	10	—

\*\*Used on 12 gauge - 20 amp circuit.

**NOTE:** AWG = American Wire Gauge

When working with the tool outdoors, use an extension cord that is designed for outside use. This is indicated by the letters "WA" on the cord's jacket.

Before using an extension cord, inspect it for loose or exposed wires and cut or worn insulation.

**WARNING:** Keep the extension cord clear of the working area. Position the cord so that it will not get caught on lumber, tools or other obstructions while you are working with a power tool. Failure to do so can result in serious personal injury.

**WARNING:** Check extension cords before each use. If damaged replace immediately. Never use tool with a damaged cord since touching the damaged area could cause electrical shock resulting in serious injury.

## ELECTRICAL CONNECTION

This tool is powered by a precision built electric motor. It should be connected to a **power supply that is 120 volts, 60 Hz, AC only (normal household current)**. Do not operate this tool on direct current (DC). A substantial voltage drop will cause a loss of power and the motor will overheat. If the saw does not operate when plugged into an outlet, double check the power supply.

## SPEED AND WIRING

The no-load speed of this tool is approximately 1,600 spm. This speed is not constant and decreases under a load or with lower voltage. For voltage, the wiring in a shop is as important as the motor's horsepower rating. A line intended only for lights cannot properly carry a power tool motor. Wire that is heavy enough for a short distance will be too light for a greater distance. A line that can support one power tool may not be able to support two or three tools.

## GROUNDING INSTRUCTIONS

In the event of a malfunction or breakdown, grounding provides a path of least resistance for electric current to reduce the risk of electric shock. This tool is equipped with an electric cord having an equipment-grounding conductor and a grounding plug. The plug must be plugged into a matching outlet that is properly installed and grounded in accordance with all local codes and ordinances.

Do not modify the plug provided. If it will not fit the outlet, have the proper outlet installed by a qualified electrician. Improper connection of the equipment-grounding conductor can result in a risk of electric shock. The conductor with insulation having an outer surface that is green with or without yellow stripes is the equipment-grounding conductor. If repair or replacement of the electric cord or plug is necessary, do not connect the equipment-grounding conductor to a live terminal.

Check with a qualified electrician or service personnel if the grounding instructions are not completely understood, or if in doubt as to whether the tool is properly grounded.

Repair or replace a damaged or worn cord immediately.

This tool is intended for use on a circuit that has an outlet like the one shown in figure 1. It also has a grounding pin like the one shown.

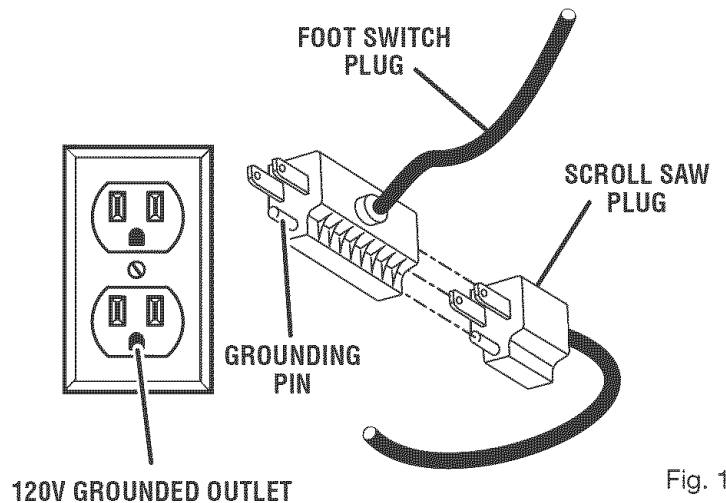

Fig. 1



# GLOSSARY OF TERMS

## **Anti-Kickback Pawls (radial arm and table saws)**

A device which, when properly installed and maintained, is designed to stop the workpiece from being kicked back toward the front of the saw during a ripping operation.

## **Arbor**

The shaft on which a blade or cutting tool is mounted.

## **Bevel Cut**

A cutting operation made with the blade at any angle other than 90° to the table surface.

## **Chamfer**

A cut removing a wedge from a block so the end (or part of the end) is angled rather than at 90°.

## **Compound Cut**

A cross cut made with both a miter and a bevel angle.

## **Cross Cut**

A cutting or shaping operation made across the grain or the width of the workpiece.

## **Cutterhead (planers and jointer planers)**

A rotating cutterhead with adjustable blades or knives. The blades or knives remove material from the workpiece.

## **Dado Cut**

A non-through cut which produces a square-sided notch or trough in the workpiece (requires a special blade).

## **Featherboard**

A device used to help control the workpiece by guiding it securely against the table or fence during any ripping operation.

## **FPM or SPM**

Feet per minute (or strokes per minute), used in reference to blade movement.

## **Freehand**

Performing a cut without the workpiece being guided by a fence, miter gauge, or other aids.

## **Gum**

A sticky, sap-based residue from wood products.

## **Heel**

Alignment of the blade to the fence.

## **Kerf**

The material removed by the blade in a through cut or the slot produced by the blade in a non-through or partial cut.

## **Kickback**

A hazard that can occur when the blade binds or stalls, throwing the workpiece back toward operator.

## **Leading End**

The end of the workpiece pushed into the tool first.

## **Miter Cut**

A cutting operation made with the workpiece at any angle to the blade other than 90°.

## **Non-Through Cuts**

Any cutting operation where the blade does not extend completely through the thickness of the workpiece.

## **Pilot Hole (drill presses)**

A small hole drilled in a workpiece that serves as a guide for drilling large holes accurately.

## **Push Blocks (for jointer planers)**

Device used to feed the workpiece over the jointer planer cutterhead during any operation. This aid helps keep the operator's hands well away from the cutterhead.

## **Push Blocks and Push Sticks (for table saws)**

Devices used to feed the workpiece through the saw blade during cutting operations. A push stick (not a push block) should be used for narrow ripping operations. These aids help keep the operator's hands well away from the blade.

## **Resaw**

A cutting operation to reduce the thickness of the workpiece to make thinner pieces.

## **Resin**

A sticky, sap-based substance that has hardened.

## **Revolutions Per Minute (RPM)**

The number of turns completed by a spinning object in one minute.

## **Ripping or Rip Cut**

A cutting operation along the length of the workpiece.

## **Riving Knife/Spreader/Splitter (table saws)**

A metal piece, slightly thinner than the blade, which helps keep the kerf open and also helps to prevent kickback.

## **Saw Blade Path**

The area over, under, behind, or in front of the blade. As it applies to the workpiece, that area which will be or has been cut by the blade.

## **Set**

The distance that the tip of the saw blade tooth is bent (or set) outward from the face of the blade.

## **Snipe (planers)**

Depression made at either end of a workpiece by cutter blades when the workpiece is not properly supported.

## **Through Sawing**

Any cutting operation where the blade extends completely through the thickness of the workpiece.

## **Throw-Back**

The throwing back of a workpiece usually caused by the workpiece being dropped into the blade or being placed inadvertently in contact with the blade.

## **Workpiece or Material**

The item on which the operation is being done.

## **Worktable**

Surface where the workpiece rests while performing a cutting, drilling, planing, or sanding operation.

# FEATURES

## PRODUCT SPECIFICATIONS

Throat .....	18 in.
Blade Size .....	5 in. plain or pin
No Load Speed .....	500 - 1,600/min.
Input .....	120 V, 60 Hz, AC Only, 1.2 Amps
Net Weight.....	28 lbs.

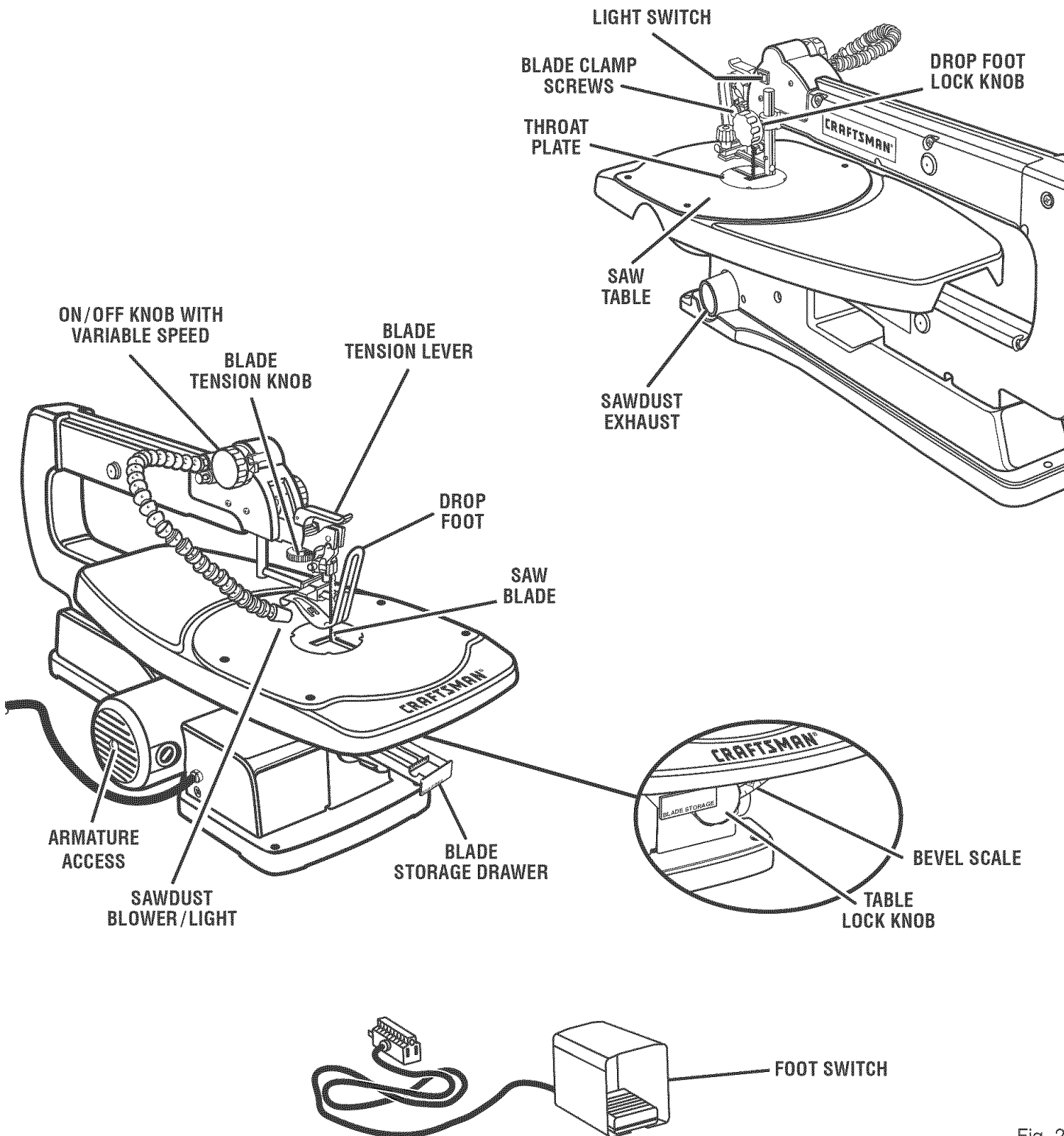

# FEATURES

## KNOW YOUR SCROLL SAW

See Figures 2 - 3.

Before attempting to use this product, familiarize yourself with all operating features and safety rules.

## BEVEL SCALE

The bevel scale and indicator show the degree the saw table is tilted.

## BLADE CLAMP SCREWS

Blade clamp screws are used when changing saw blades.

## BLADE STORAGE DRAWER

Attached under the left side of the table is a blade storage drawer. It will hold up to 20 blades.

## BLADE TENSION KNOB

Loosen or tighten blade tension by turning the blade tension knob.

## DROP FOOT AND DROP FOOT LOCK KNOB

This foot should be lowered until it just rests on top of the workpiece to prevent the workpiece from lifting, yet not so much that the workpiece drags. The vertical portion provides a blade guard to prevent accidental blade contact.

## FOOT SWITCH

Use the foot switch to conveniently turn your scroll saw off and on.

## LOCK POST

To prevent unauthorized use of the scroll saw, we suggest that you disconnect it from the power supply and install a padlock (not supplied) through the lock post beside the knob, as illustrated, to lock the knob in the **OFF** position. When the lock is properly installed and locked, the switch is inoperable. Store the padlock key in another location.

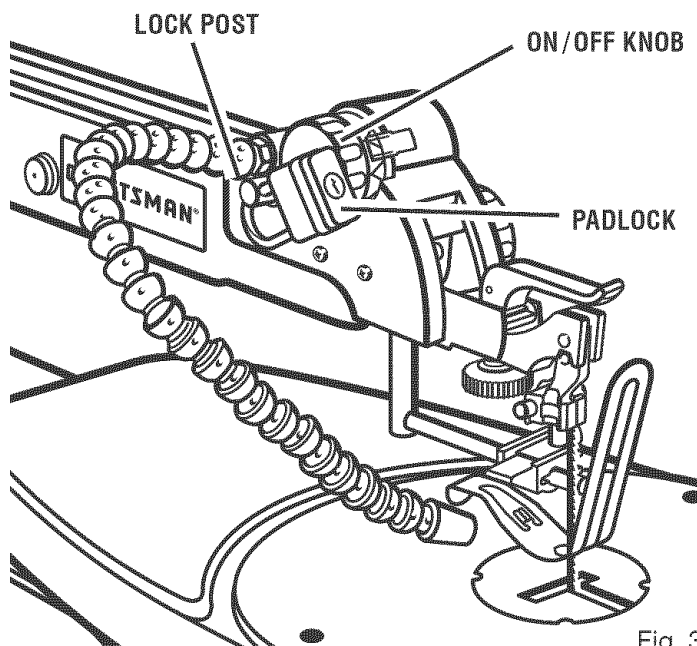

Fig. 3

**WARNING:** For your own safety, always push the knob **OFF** when machine is not in use. Also, in the event of a power failure, push knob **OFF**. Lock the scroll saw switch **OFF** with a padlock. This will prevent the machine from starting up again when the power comes back on. Failure to heed this warning can result in serious personal injury.

## ON/OFF KNOB WITH VARIABLE SPEED

Pull the knob out to turn **ON** the scroll saw and push the knob in to turn **OFF** the scroll saw. Turn the knob to adjust the speed from the high speed of approximately 1,600 SPM (strokes per minute) to the low speed of approximately 500 SPM.

## SAWDUST BLOWER/LIGHT

With a convenient **ON/OFF** switch, the sawdust blower/light keeps the line of cut on the workpiece clean and lighted for more accurate scroll cuts. Place the switch in the **ON** position, then depress the foot switch to activate the blower and/or light. For best results, always direct air flow at the blade and the workpiece.

## SAWDUST EXHAUST

This feature will allow you to attach any 1-1/4 in. vacuum hose for easy sawdust collection.

## SAW TABLE WITH THROAT PLATE

Your scroll saw has an aluminum saw table with tilt control for maximum accuracy. The throat plate inserted in the saw table allows for blade clearance.

## SWITCH

A power switch turns the sawdust blower/light on and off.

## TABLE LOCK KNOB

Allows you to tilt the table and lock it at any desired angle from 5° left to 45° right.

## TOOLS NEEDED

The following tools (not included) are needed for making adjustments:

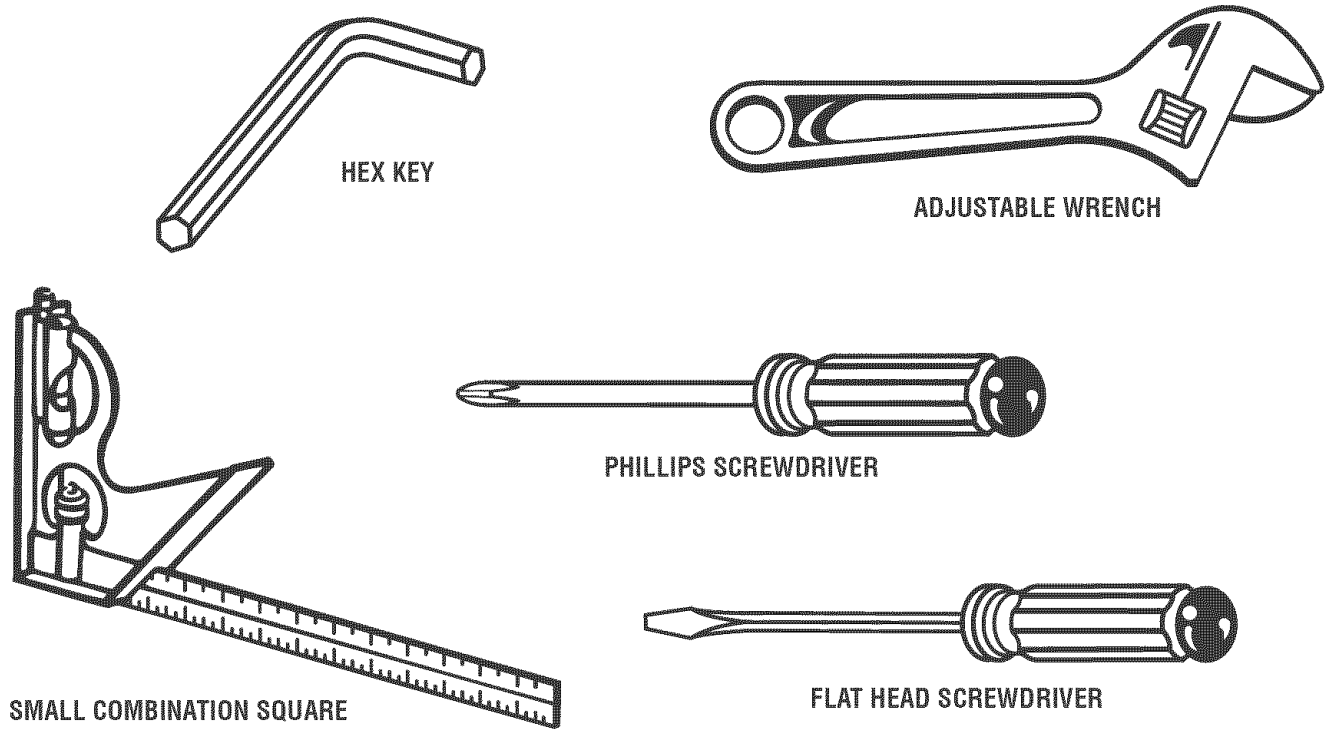

Fig. 4

## LOOSE PARTS

The following items are included with the tool:

- Plain Blades (3)
- Pin Blades (2)
- Operator's Manual (Not Shown)

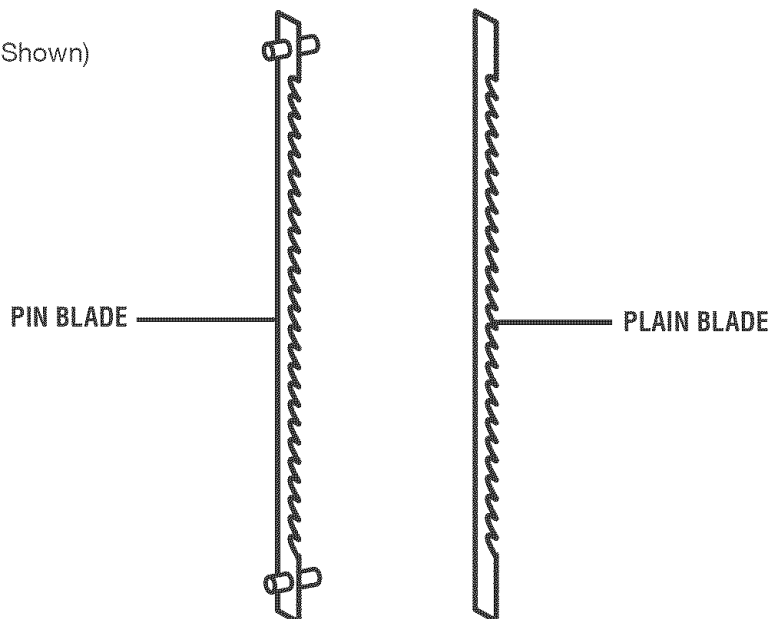

Fig. 5

**WARNING:** The use of attachments or accessories not listed might be hazardous and could cause serious personal injury.

# ASSEMBLY

## UNPACKING

This product has been shipped completely assembled.

- Carefully lift the saw from the carton and place it on a level work surface.
- Inspect the tool carefully to make sure no breakage or damage occurred during shipping.
- Do not discard the packing material until you have carefully inspected and satisfactorily operated the tool.
- The saw is factory set for accurate cutting. After assembling it, check for accuracy. If shipping has influenced the settings, refer to specific procedures explained in this manual.
- If any parts are damaged or missing, please call 1-800-932-3188 for assistance.

**WARNING:** If any parts are missing, do not operate this tool until the missing parts are replaced. Failure to do so could result in possible serious personal injury.

**WARNING:** Do not attempt to modify this tool or create accessories not recommended for use with this tool. Any such alteration or modification is misuse and could result in a hazardous condition leading to possible serious personal injury.

**WARNING:** Do not connect to a power supply until assembly is complete. Failure to comply could result in accidental starting and possible serious personal injury.

## MOUNTING SCROLL SAW TO WORKBENCH

**WARNING:** To avoid serious personal injury from unexpected tool movement, always securely mount scroll saw to a workbench.

If the scroll saw is to be used in a permanent application, we recommend that you secure it in a permanent location such as a workbench. When mounting the saw to a workbench, holes should be drilled through the supporting surface of the workbench.

- Each hole in the base of the saw should be bolted securely using machine bolts, washers, and nuts (not included). Bolts should be of sufficient length to accommodate the saw base, washers, nuts, and the thickness of the workbench.
- Place scroll saw on workbench. Using the saw base as a pattern, locate and mark the holes where the scroll saw is to be mounted.
- Drill three holes through the workbench.
- Place scroll saw on workbench aligning holes in the saw base with the holes drilled in the workbench.
- Insert all three bolts (not included) and tighten securely with washers and nuts (not included).

**NOTE:** All bolts should be inserted from the top. Install the washers and nuts from the underside of the bench.

The supporting surface where the scroll saw is mounted should be examined carefully after mounting to insure that no movement during use can result. If any tipping or walking is noted, secure workbench or supporting surface before beginning cutting operations.

### To Reduce Noise and Vibration:

You may wish to place a foam pad or piece of carpet between the saw base and the workbench to help reduce noise and vibration.

If a foam pad or piece of carpet is used, do not overtighten the mounting bolts. Leave some cushion between the padding and the saw base to help absorb the noise and vibration.

The size of the padding material should be approximately 24 in. x 12 in. x 1/2 in.

## CLAMPING SCROLL SAW TO WORKBENCH

See Figure 6.

If the scroll saw is to be used in a portable application, it is recommended that you fasten it permanently to a mounting board that can easily be clamped to a workbench or other supporting surface. The mounting board should be of sufficient size to avoid tipping of saw while in use. Any good grade plywood or chipboard with a 3/4 in. thickness is recommended.

- Mount saw to board using holes in saw base as a template for hole pattern. Locate and mark the holes where scroll saw is to be mounted.
- Follow last three steps in previous section called **Mounting Scroll Saw to Workbench**.

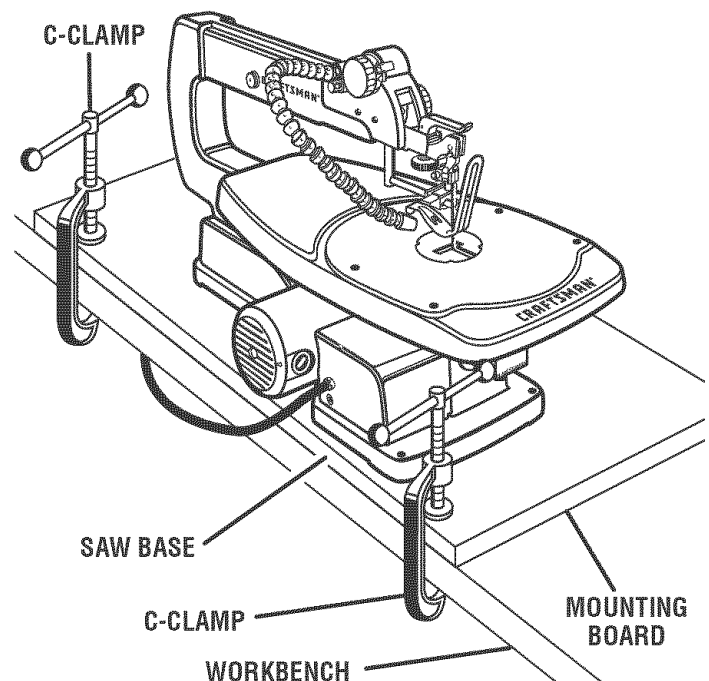

Fig. 6

# ASSEMBLY

If lag bolts are being used, make sure they are long enough to go through holes in the saw base and the material to which the saw is being mounted.

If machine bolts are being used, make sure they are long enough to go through holes in the saw base, the material the saw is being mounted to, and the washers and nuts.

**NOTE:** It may be necessary to countersink washers and nuts on the bottom side of mounting board.

## SQUARING THE SAW TABLE TO THE BLADE

See Figures 7 - 8.

- Loosen the drop foot lock knob and move drop foot rod all the way up. Retighten drop foot lock knob.
- Loosen the table lock knob to tilt the saw table until it is approximately perpendicular or at a right angle to the blade.
- Place a small combination square on the saw table next to the blade to check squareness.
- Loosen the screw holding the scale indicator. Move indicator to the 0° mark and securely tighten screw. Remember, the bevel scale is a convenient guide but

should not be relied upon for precision. Make practice cuts on scrap material to determine if your angle settings are correct.

- Adjust the drop foot to desired position and securely retighten the drop foot lock knob.

## SETTING THE TABLE FOR HORIZONTAL OR BEVEL CUTTING

See Figures 8 - 10.

A bevel scale is located under the saw table as a convenient guide for setting the approximate saw table angle for bevel cutting. When greater precision is required, make practice cuts on scrap material and adjust the saw table as necessary for your requirements.

**NOTE:** When cutting at angles, the drop foot should be tilted so it is parallel to the saw table and rests flat against the workpiece. To tilt the drop foot, loosen phillips screw, tilt drop foot to the proper angle, then retighten screw.

- Loosen the table lock knob and push down on the right side of the table. If the table stops at 0°, the zero degree stop is properly set. If the table stops somewhere other than zero, adjust the zero degree stop.

**To adjust:**

- To access the zero degree stop, loosen the table lock knob, and tilt the table with the right side all the way down. Just under the front of the saw table is the zero degree stop.
- Loosen the hex nut and rotate the hex bolt to raise or lower the bolt as needed to adjust the zero degree stop. Be sure to check to see that the table is square to the blade.

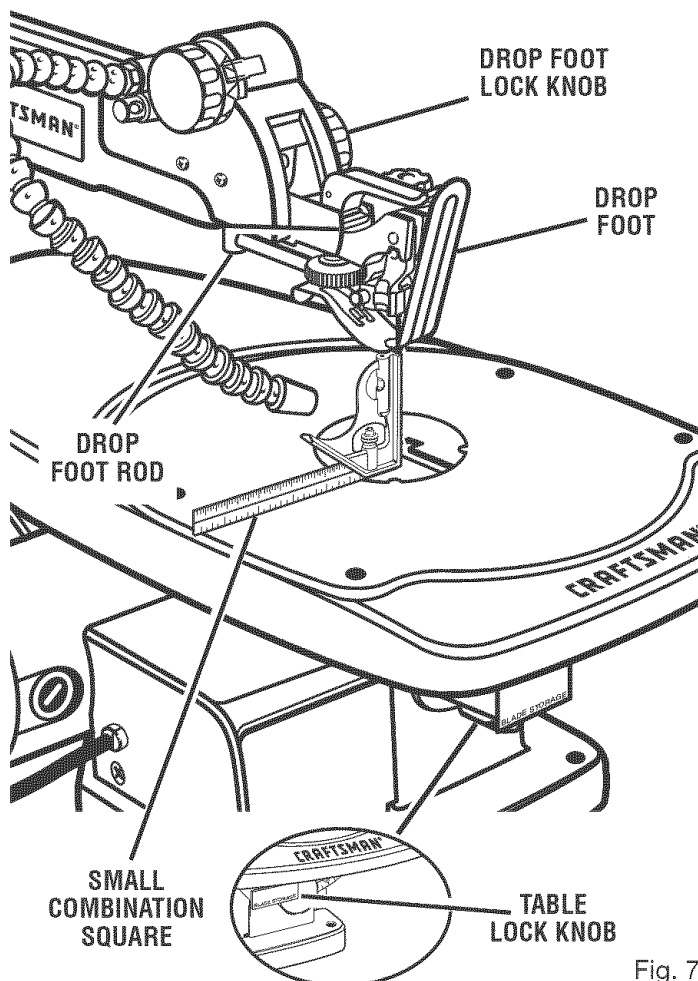

Fig. 7

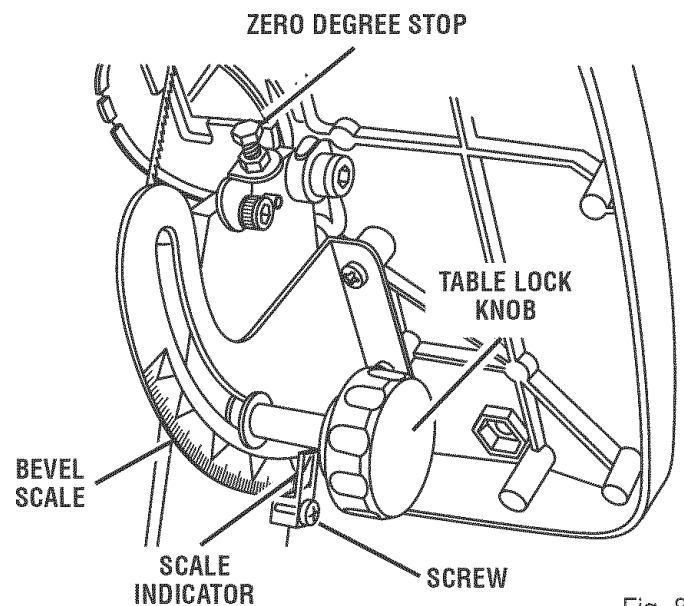

Fig. 8

# ASSEMBLY

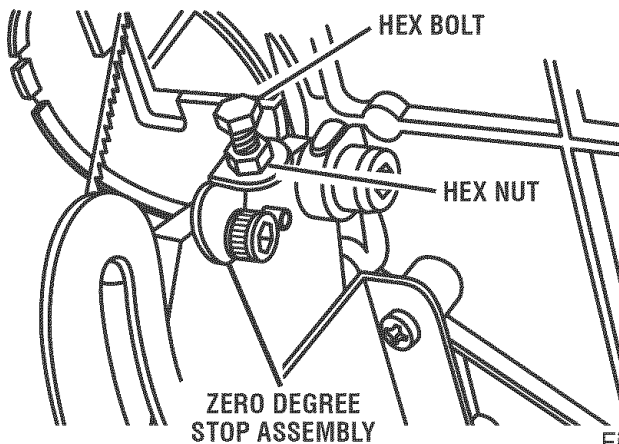

Fig. 9

- Now, by returning the table to the zero position, the zero degree stop provides a quick reference to the preset position.

The zero stop assembly can be rotated to the left and

down out of the way, and the table can be angled up to 12° to the left.

**NOTE:** Make sure the zero degree stop is rotated all the way down or it will contact the blade storage drawer as you angle to the left.

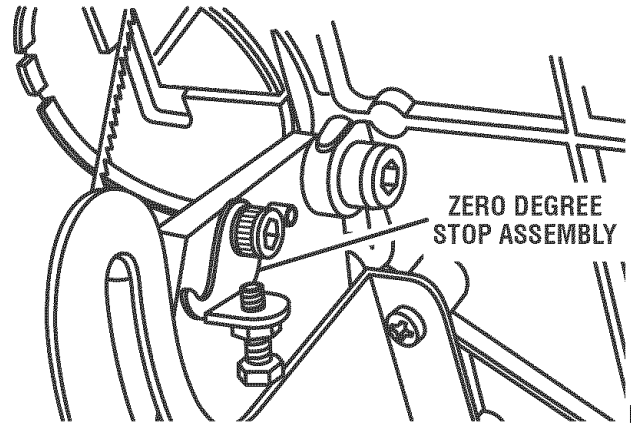

Fig. 10

# OPERATION

**WARNING:** Do not allow familiarity with tools to make you careless. Remember that a careless fraction of a second is sufficient to inflict severe injury.

**WARNING:** Always wear safety goggles or safety glasses with side shields when operating tools. Failure to do so could result in objects being thrown into your eyes resulting in possible serious injury.

**WARNING:** Do not use any attachments or accessories not recommended by the manufacturer of this tool. The use of attachments or accessories not recommended can result in serious personal injury.

**WARNING:** To prevent serious personal injury, never leave the saw unattended until the blade has come to a complete stop.

## APPLICATIONS

You may use this tool for the following purposes:

- Cutting wood, wood composition products, plastic, and other fibrous material up to 2 in. thick
- Cutting nonferrous metals such as aluminum, brass, and copper

**WARNING:** Before starting any cutting operation, clamp or bolt the saw to a workbench. Never operate the saw on the floor or in a crouched position. Failure to heed this warning can result in serious personal injury.

## BASIC OPERATION OF THE SCROLL SAW

Before starting a cut, watch the saw run. If you experience excessive vibration or unusual noise, stop immediately. Turn the saw off, remove the switch key, and unplug saw. Do not restart until locating and correcting the problem.

**NOTE:** After the saw is turned **ON**, a hesitation before blade movement is normal.

## CUTTING PROCEDURES

- During each person's learning period on this saw, it is expected that some blades will break until proper use and adjustments are learned.
- Plan how to hold the workpiece from start to finish.
- Keep your hands away from the blade. Do not hand hold pieces so small your fingers will go under the blade guard.
- Hold the workpiece firmly against the saw table.
- Use gentle pressure and both hands when feeding the work into the blade. Do not force the work.
- Guide the workpiece into the blade slowly because the teeth of the blade are very small and can only remove material on the down stroke.
- Avoid awkward operations and hand positions where a sudden slip could cause serious injury from contact with the blade. Never place hands in blade path.
- To get accurate cuts, compensate for blade's tendency to follow the wood grain as you are cutting wood.
- Use extra supports (tables, saw horses, blocks, etc.) when cutting large, small or awkward workpieces.

# OPERATION

- Never use another person as a substitute for a table extension or as additional support for a workpiece that is longer or wider than the basic saw table.
- When cutting irregularly shaped workpieces, plan your work so it will not pinch the blade. Workpieces must not twist, rock or slip while being cut.

## AVOIDING INJURY

- Make sure saw is level and does not rock. Saw should always be on a firm, level surface with plenty of room for handling and properly supporting the workpiece.
- Bolt saw to the support surface to prevent slipping, walking or sliding during operations like cutting long, heavy boards.
- Turn saw off, remove switch key, and unplug cord from the power source before moving the saw.
- Do not remove jammed cutoff pieces until blade has come to a full and complete stop.
- Choose the right size and style blade for the material and type of cut you plan to do.
- Use only recommended accessories.
- With the exception of the workpiece and related support devices, clear everything off the saw table before turning the saw on.

- Properly support round materials such as dowel rods or tubing because they have a tendency to roll during a cut causing the blade to “bite.” To avoid this, always use a “V” block or clamp workpiece to a miter gauge
- Before removing loose pieces from the saw table, turn saw off and wait for all moving parts to stop.

## REMOVING JAMMED MATERIAL

When backing out the workpiece, the blade may bind in the kerf (cut). This is usually caused by sawdust clogging the kerf or when the blade comes out of the blade holders. If this happens:

- Wait until saw has come to a full and complete stop.
- Place the switch in the **OFF** position.
- Unplug the saw from the power source.
- Remove the saw’s blade and the workpiece. See **Removing the Saw Blade**.
- Wedge the kerf open with a flat screwdriver or wooden wedge, then remove the blade from the workpiece.



**WARNING:** To avoid serious personal injury, turn saw off and wait for all moving parts to stop before removing loose pieces from the table.

Teeth/ Inch	Width	Thickness	Speed or Strokes Per Minute	Material Cut
10	.110 in. (2.8 mm)	.020 in. (0.5 mm)	500-1600	Popular size for cutting hard and soft woods 3/16 in. (4.8 mm) up to 2 in. (51 mm) Plastics, paper, felt, bone, etc.
7	.067 in. (1.1 mm)	.020 in. (0.5 mm)	750-1250	Extremely thin cuts on materials 3/32 in. (2.4 mm) to 1/2 in. (13 mm) thick Wood, plastics
13	.037 in. (0.5 mm)	.015 in. (0.4 mm)	500-1000	For tight radius work in thin materials 3/32 in. (2.4 mm) to 1/8 in. (3 mm) Wood, veneer, bone, fiber, ivory, plastic, etc.

## BLADE INFORMATION

- Scroll saw blades wear out and must be replaced frequently for best cutting results. Scroll saw blades generally stay sharp for 1/2 hour to 2 hours of cutting, depending on type of material and speed of operation.
- When cutting wood, best results are achieved when cutting wood less than one inch thick.
- When cutting wood thicker than one inch, the user must guide the workpiece very slowly into the blade and take extra care not to bend or twist the blade while cutting.

- When choosing a blade, carefully consider the following:
  - Very fine, narrow blades should be used to scroll cut in thin material 1/4 in. (6 mm) thick or less.
  - Most blade packages state the size or thickness and type of material which that blade is intended to cut. The package should also state the radius or size of curve that can be cut with that blade size.
  - Wider blades cannot cut curves as tight or as small as thinner blades.
- Blades wear faster when:
  - Cutting plywood, hardwood, and other laminates.
  - Cutting material thicker than 3/4 in.
  - Side pressure is applied to the blade.



# OPERATION

## CHOICE OF BLADE AND SPEED

The scroll saw accepts a wide variety of blade widths and thicknesses for cutting wood and other fibrous materials. It uses 5 in. long blades of either the pin end or plain end style. The blade width and thickness and the number of teeth per inch to use are determined by the type of material and the size of the radius being cut.

**NOTE:** As a general rule, always select narrow blades for intricate curve cutting and wide blades for straight and large curve cutting.

## INSTALLING BLADES

See Figure 11.

Scroll saw blades wear out quickly and must be replaced frequently for best cutting results. Expect to break some blades while you learn to use and adjust the saw. Blades generally stay sharp for 1/2 hour to 2 hours of cutting, depending on the type of material and speed of operation.

### PIN BLADES

#### Removing the Saw Blade:

- Turn off the saw and unplug from power source.

**WARNING:** Failure to turn the saw off and unplug the saw from the power source could result in accidental starting causing possible serious injury.

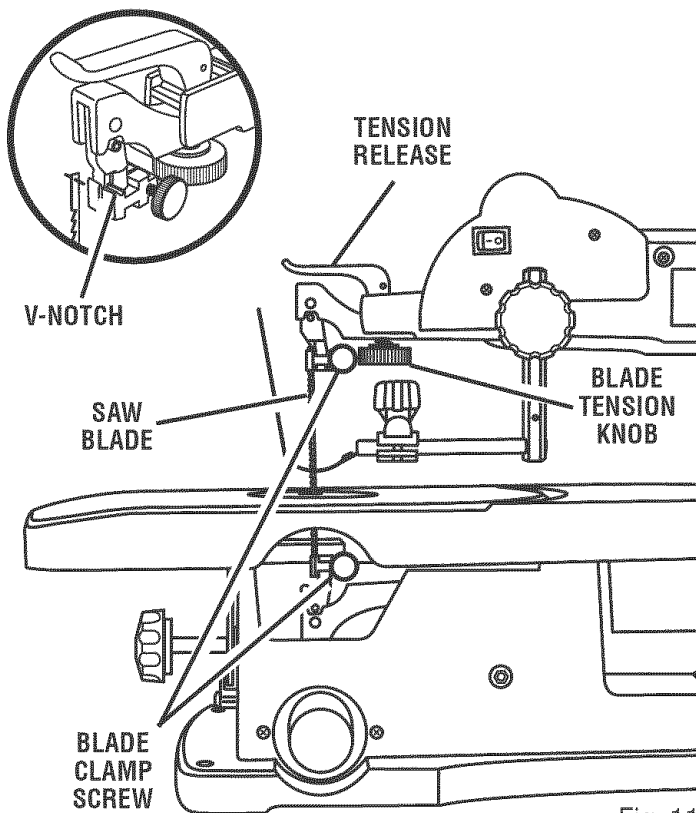

Fig. 11

- Pull up on the tension release.
- Turn blade tension knob clockwise to decrease (or loosen) blade tension.
- Pushing up from under the saw table, remove the throat plate.
- Loosen both the upper and lower blade clamp screws.
- Pull up on the blade and push down on the saw arm to disengage the upper pin in the V-notch of the upper blade holder. Push the blade downward to disengage the lower pin in the lower blade holder.
- Remove the blade.

#### Replacing the Saw Blade:

- Turn off the saw and unplug from power source.
- Place the new blade through the opening in the saw table with the teeth to the front of the saw and pointing down toward the saw table. The pins on the blade go under the blade holder in the lower blade holder.
- Pull up on the blade and press the upper arm down to position the upper end of the blade in the V-notch in the upper blade holder.
- Securely tighten the upper and lower blade clamp screws.
- Push the tension release back down.
- Turn the blade tension knob counterclockwise until the blade has the desired amount of tension.
- Replace the throat plate.

**NOTE:** If the blade touches the drop foot on either side then the drop foot must be adjusted. See **Adjusting Drop Foot** in the Adjustments section of this manual.

### PLAIN BLADES

#### Removing the Saw Blade:

- Turn off the saw and unplug from power source.
- Pull up on the tension release.
- Turn blade tension knob counterclockwise to decrease (or loosen) blade tension.
- Pushing up from under the saw table, remove the throat plate.
- Loosen both the upper and lower blade clamp screws.
- Remove the blade.

#### Replacing the Saw Blade:

- Turn off the saw and unplug from power source.
- Place the new blade through the opening in the saw table with the teeth to the front of the saw and pointing down toward the saw table.
- Position blade and tighten the lower blade clamp screw securely.

# OPERATION

- Pull up on the blade and press the upper arm down to position the upper end of the blade in the upper blade holder.
- Securely tighten the upper blade clamp screw.
- Push the tension release back down.
- Turn the blade tension knob clockwise until the blade has the desired amount of tension.
- Replace the throat plate.

**NOTE:** If the blade touches the drop foot on either side then the drop foot must be adjusted. See **Adjusting Drop Foot** in the Adjustments section of this manual.

## DROP FOOT

See Figure 12.

To prevent the workpiece from lifting, the drop foot should be adjusted so it just rests on the top of the workpiece. The drop foot should not be adjusted so that the workpiece drags.

Always retighten the drop foot lock knob after each adjustment has been made.

- Loosen the drop foot lock knob.
- Lower or raise the drop foot to the desired position.
- Retighten the drop foot lock knob.

The tall, front part of the drop foot acts as a blade guard to prevent accidental contact with the blade.

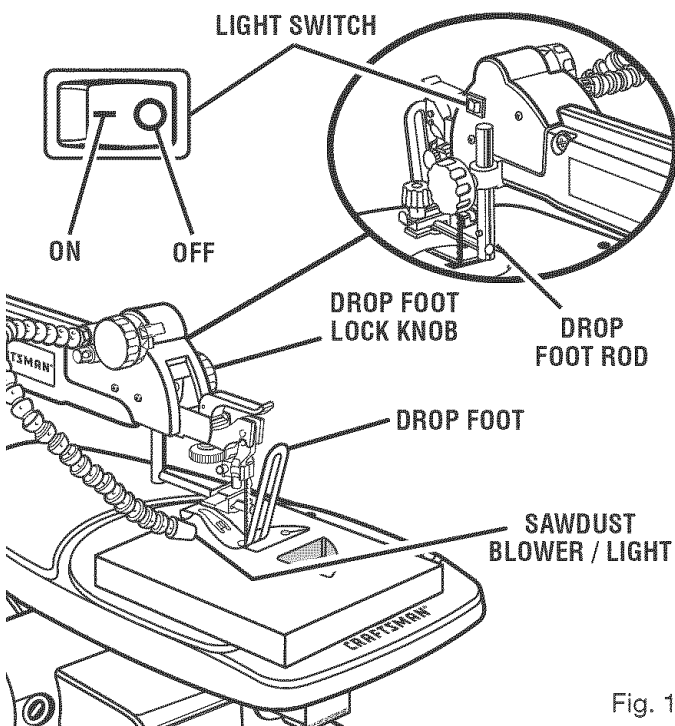

Fig. 12

**WARNING:** Do not use this foot switch with any tool other than 21609 Scroll Saw. Failure to follow this warning may result in serious injury.

## TURNING THE SCROLL SAW ON AND OFF

See Figures 13 - 14.

- Plug the foot switch into the power source.
- Plug the scroll saw into the foot switch.

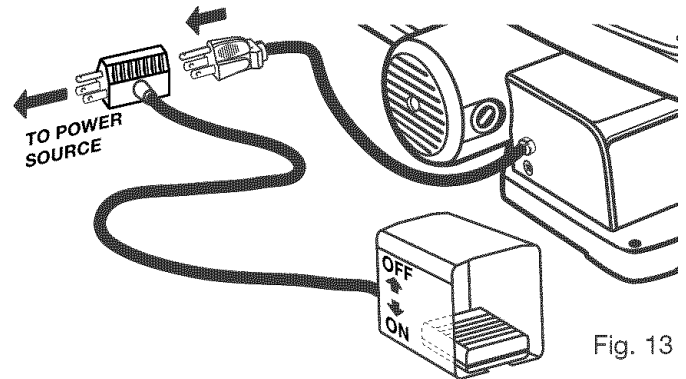

Fig. 13

- Pull the ON/OFF knob out to the **ON** position. The knob must remain in this position for the foot switch to supply power to the saw.
- Depress foot switch to turn saw **ON**.  
**NOTE:** After saw is turned on, a hesitation before blade movement is normal.
- Release foot switch to turn saw **OFF**.

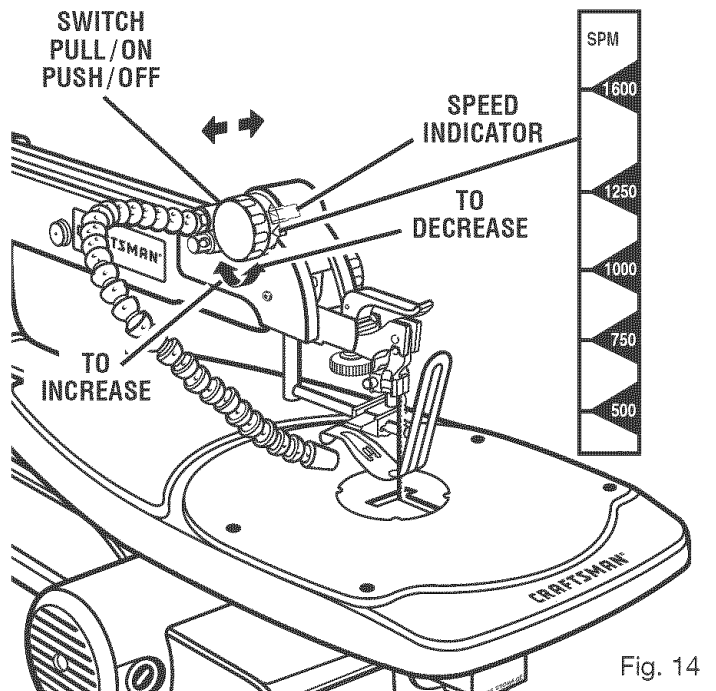

Fig. 14

## VARIABLE SPEED

See Figure 14.

The ON/OFF knob also controls the variable speed of the saw. By turning the knob, the variable speed control may be adjusted from the high speed of approximately 1,600 SPM to the low speed of approximately 500 SPM. Turn the ON/OFF knob clockwise to increase strokes per minute and counterclockwise to reduce the strokes per minute.

# OPERATION

This motor has an electronic control that regulates the speed and provides overload protection to the motor. If the motor fails to start after about two seconds, push the knob **OFF** and disconnect the saw from the power source. Refer to the troubleshooting chart.

**NOTE:** If the internal overload protector has been tripped, pushing the ON/OFF knob **OFF** will reset it.

## SCROLL CUTTING

For general scroll cutting, follow the pattern lines by pushing and turning the workpiece at the same time. Attempting to turn the workpiece without also pushing it could cause the workpiece to bind or twist the blade.

## INTERIOR SCROLL CUTTING

See Figure 15.

One convenient feature of a scroll saw is that it can be used to make scroll cuts on the interior of a workpiece without breaking or cutting through the edge or perimeter of the board.

### To make interior cuts in the workpiece:

- Remove the scroll saw blade as explained in the **Installing Blades** section previously in this manual.
- Drill a 1/4 in. (6 mm) hole in the workpiece.
- Place the workpiece on the saw table with the drilled hole over the access hole in the table.
- Install the blade through the hole in the workpiece; adjust the drop foot and blade tension.
- When finished making the interior scroll cuts, simply remove the blade from the blade holders as described in the **Installing Blades** section, and remove the workpiece from the saw table.

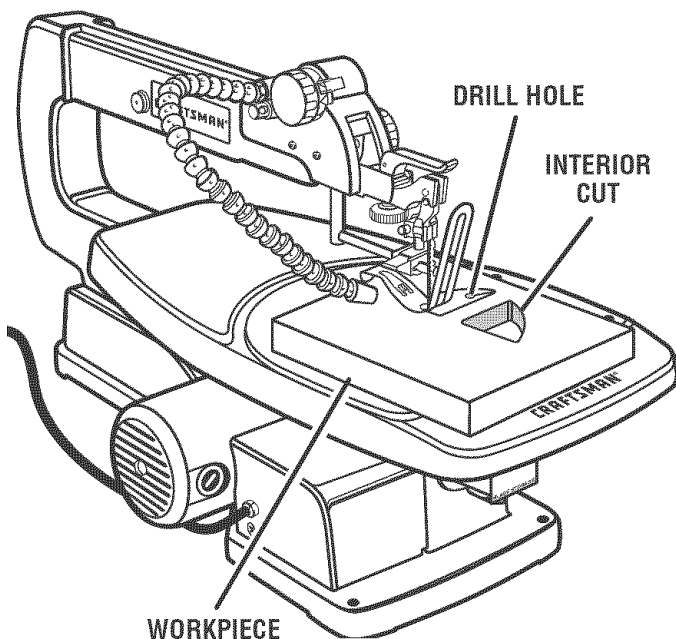

Fig. 15

## STACK CUTTING

See Figure 16.

After becoming well acquainted with the saw through practice and experience, you may wish to try stack cutting. Stack cutting may be used when several identical shapes need to be cut. Several pieces of wood may be stacked on top and secured to each other before cutting. The wood pieces may be joined together by placing double-sided tape between each piece or by wrapping masking tape around the corners or ends of the stacked wood. You must attach the stacked pieces of wood to each other so they will move on the table as a single piece of material.

**WARNING:** To avoid possible serious personal injury, do not cut more than one loose piece of material at a time.

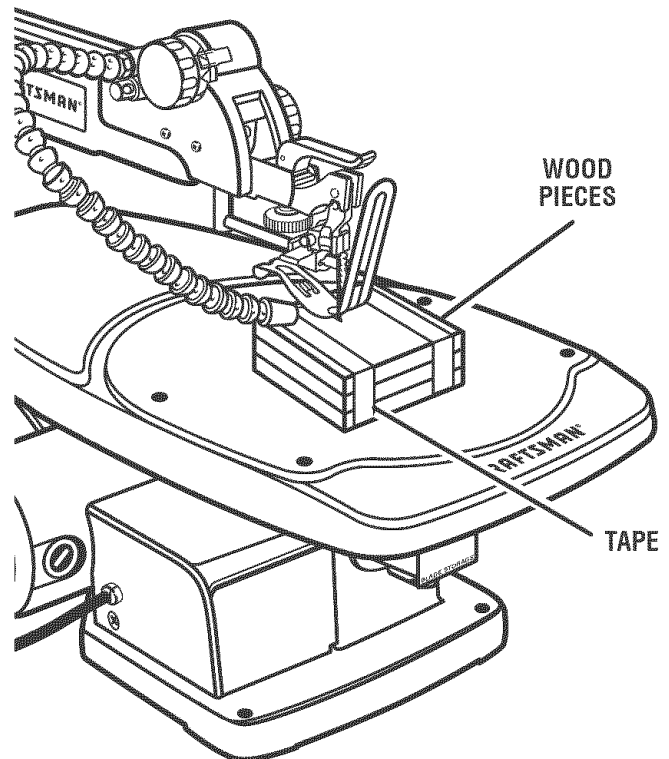

Fig. 16

## ADJUSTMENTS

**WARNING:** Before performing any adjustment, make sure the tool is unplugged from the power supply and the switch is in the OFF ( O ) position. Failure to heed this warning could result in serious personal injury.

### ADJUSTING DROP FOOT

- Loosen the drop foot lock knob.
- Center the drop foot around the saw blade to the desired position.
- Tighten the drop foot lock knob.

### ADJUSTING BLADE TENSION

See Figure 17.

Adjustments to blade tension can be made at any time. Check the blade tension by the sound the blade makes when plucked like a guitar string. This method can be developed with practice and requires knowing the scroll saw.

Pluck the back straight edge of blade while turning blade tension knob. The sound should be a musical note. The sound becomes less flat as tension increases, and decreases with too much tension.

#### To adjust the blade tension:

- Turn off and unplug the saw from the power source.

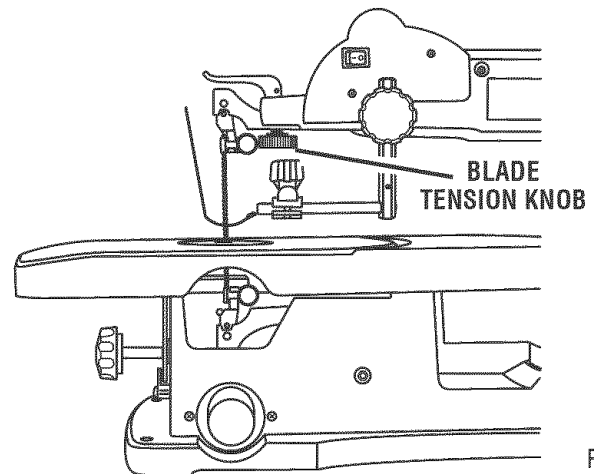

Fig. 17

- Turn the blade tension knob clockwise to decrease (or loosen) the blade tension.  
**NOTE:** Be careful not to make the blade too loose. Too little tension may cause the blade to bend or break before the teeth wear out.
- Turn the blade tension knob counterclockwise to increase (or tighten) blade tension.  
**NOTE:** Be careful not to adjust the blade too tightly. Too much tension may cause the blade to break as soon as you start cutting.

## MAINTENANCE

**WARNING:** When servicing, use only identical replacement parts. Use of any other part may create a hazard or cause product damage.

**WARNING:** Always wear safety goggles or safety glasses with side shields during power tool operation or when blowing dust. If operation is dusty, also wear a dust mask.

### GENERAL

Avoid using solvents when cleaning plastic parts. Most plastics are susceptible to damage from various types of commercial solvents and may be damaged by their use. Use clean cloths to remove dirt, carbon dust, etc.

**WARNING:** Do not at any time let brake fluids, gasoline, petroleum-based products, penetrating oils, etc. come in contact with plastic parts. Chemicals can damage, weaken or destroy plastic which may result in serious personal injury.

It has been found that electric tools are subject to accelerated wear and possible premature failure when they are used on fiberglass boats, sports cars, wallboard, spackling compounds, or plaster. The chips and grindings from these materials are highly abrasive to electric tool parts such as bearings, brushes, commutators, etc. Consequently, it is not recommended that this tool be used for extended work on any fiberglass material, wallboard, spackling compounds, or plaster. During any use on these materials it is extremely important that the tool is cleaned frequently by blowing with an air jet.

- Keep the scroll saw clean.
- After cleaning the table top initially, apply a thin coat of automobile type (paste) wax to the table top so the wood slides easily while cutting.
- Do not allow pitch to accumulate on the saw table. Clean with gum and pitch remover.

# MAINTENANCE

## ARM BEARINGS

See Figure 18.

Lubricate the arm bearings after the first 10 hours of use. Oil after every 50 hours of use or whenever there is a squeak coming from the bearings.

- Carefully place the saw on its side as shown.
- Remove the rubber cap from the upper and the lower arm of the saw.
- Squirt a few drops of SAE20 oil around the shaft end and arm bearings. Let oil soak in overnight, remaining in this position.

**NOTE:** Lubricate the bearings on the other side of the saw in this same manner.

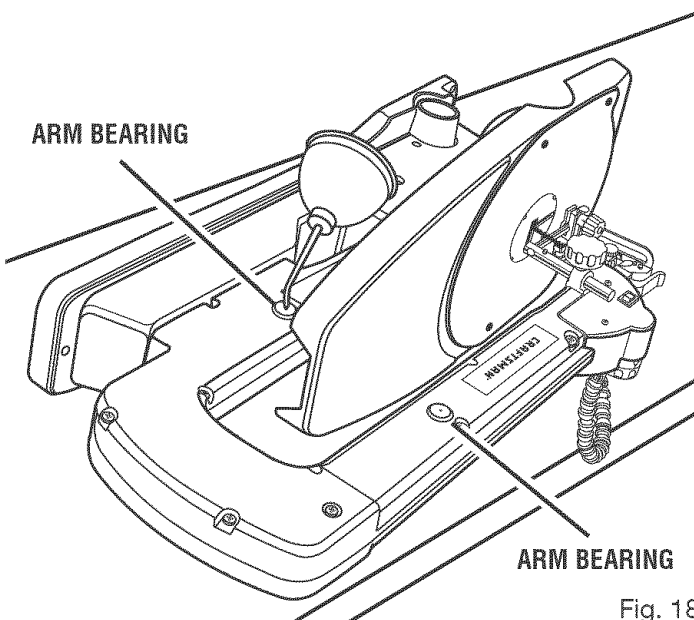

Fig. 18

## MOTOR BRUSHES

See Figure 19.

The saw has externally accessible motor brush assemblies that should be checked periodically for wear. When either one of the two brushes becomes worn, replace both brushes.

- Unplug the saw from the power source.
- Carefully place the saw on its side, exposing the underside of the saw housing.
- Using a flat blade screwdriver, remove the bottom brush assembly cap through the access hole in the base and the top brush assembly cap from the top of the motor.
- Gently pry the brush assemblies out using a small screwdriver, point of a nail, or paper clip.
- If one motor brush is worn down shorter than 1/4 in., replace both motor brushes. Do not replace one side without replacing the other.

**NOTE:** Ensure curvature of brush matches curvature of motor, and that motor brush moves freely in brush tube. Use the blunt end of something thin (eraser end of pencil, etc.) to push the motor brush into the tube until it stays.

- Ensure the motor brush cap is oriented correctly (straight), then tighten motor brush cap using a hand powered screwdriver only. Do not overtighten.

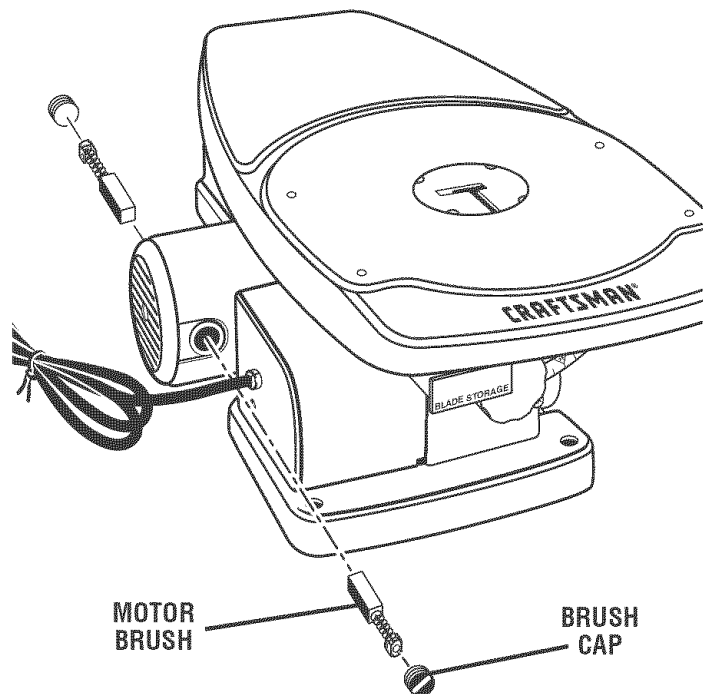

Fig. 19

# TROUBLESHOOTING

PROBLEM	CAUSE	SOLUTION
Motor will not run.	<p>Problem with ON/OFF switch, power cord, foot switch, or outlet</p> <p>Motor defective</p>	<p>Have worn parts replaced before using scroll saw again. Have the proper outlet installed by a qualified electrician.</p> <p>Do not attempt any repair. Have repaired by a qualified service technician.</p>
Blades breaking.	<p>Too much tension</p> <p>Feeding too quickly</p> <p>Wrong blade</p> <p>Blade twisting in wood</p>	<p>Adjust tension.</p> <p>Reduce feed rate.</p> <p>Use narrow blades for cutting thin wood or tight corners and turns; use wide blades for thicker wood or wide turns.</p> <p>Reduce side pressure on blade; check blade tension.</p>
Vibration (there is always some vibration when the saw is running).	<p>Improper mounting of saw</p> <p>Mounting surface</p> <p>Loose table or table resting against motor</p> <p>Loose motor mounting</p>	<p>Check mounting.</p> <p>Check mounting in manual.</p> <p>Tighten table lock knob.</p> <p>Tighten mounting screws.</p>
Blade runout (blade not properly aligned with arm motion).	Blade holders out of line	Realign blade.



CRAFTSMAN 18 in. (457 mm) SCROLL SAW - MODEL NO. 216090

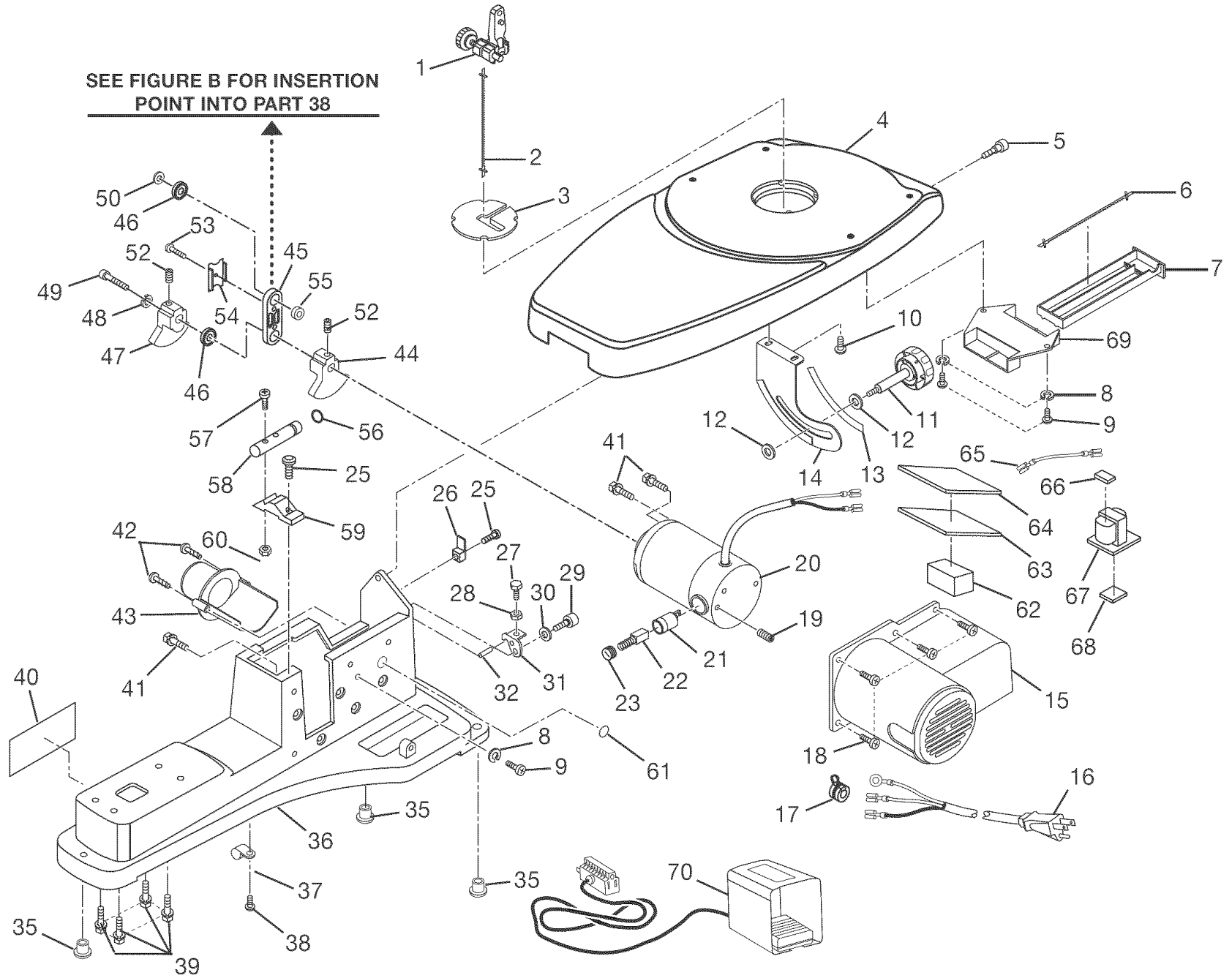

FIGURE A



**CRAFTSMAN 18 in. (457 mm) SCROLL SAW – MODEL NO. 216090**

**PARTS LIST FOR FIGURE A**

KEY NO.	PART NUMBER	DESCRIPTION	QTY.	KEY NO.	PART NUMBER	DESCRIPTION	QTY.
1	180A02030	Upper Clamp Assembly .....	1	37	E07000846157	Clamp (UC-15) .....	3
2	101069006	Saw Blade .....	3	38	A10003050105	* Screw (M5 x 10 Pan Hd.) .....	3
3	180308000	Throat Plate .....	1	39	979769001	* Hex Bolt (M6 x 20) .....	4
4	180309000	Table .....	1	40	180257000	Data Plate .....	1
5	979809001	Table Screw .....	1	41	A03003050168	* Hex Bolt (M5 x 16) .....	3
6	101072009	Saw Blade .....	2	42	979766001	* Screw (M4 x 30) .....	2
7	180310000	Blade Drawer .....	1	43	979767001	Nozzle .....	1
8	A37130510060	* Washer (M5) .....	3	44	979775001	Left Counterbalance .....	1
9	979730001	* Screw (M5 x 8) .....	3	45	979762001	Link .....	1
10	A11003050083	* Screw (M5 x 8) .....	2	46	979758001	Ball Bearing (625ZZ) .....	2
11	180312000	Lock Handle .....	1	47	180237100	Right Counterbalance .....	1
12	979804001	* Washer (M6) .....	2	48	A36030508123	* Washer (M5) .....	1
13	180313000	Scale .....	1	49	180238000	Screw .....	1
14	180303000	Scale Bracket .....	1	50	180242000	Spacer .....	1
15	180102000	Motor Cover .....	1	52	979776001	Set Screw (M6 x 6 mm) .....	2
16	180105000	Power Cord Assembly .....	1	53	979759001	* Screw (M4 x 8) .....	1
17	E07050613002	Stain Relief .....	1	54	180250000	* Fixed Plate .....	1
18	A10003060103	* Screw (M6 x 10) .....	4	55	180241000	Spacer .....	1
19	A18003050109	Clamp Screw .....	2	56	A63000000051	* O-ring (P-5) .....	1
20	980123001	Motor Assembly .....	1	57	A10003040180	* Screw (M4 x 18 mm) .....	2
21	979786001	Brush Holder .....	2	58	180106000	Table Spindle .....	1
22	979785001	Brush Assembly .....	2	59	180110000	Table Pivot Stand .....	1
23	979784001	Brush Cap .....	2	60	A30003004005	* Hex Nut (M4) .....	2
25	A10003050150	* Screw (M5 x 15) .....	3	61	904222009	Label .....	1
26	979772001	Indicator .....	1	62	180108000	Large Sponge .....	2
27	979820001	* Hex Bolt (M5 x 15) .....	1	63	8180a00110	Pc Board .....	1
28	979821001	* Hex Nut (M5) .....	1	64	180112000	Insulation Film .....	1
29	979822001	Hex Bolt (Socket Hd. Special) .....	1	65	180101000	Lead Wire .....	1
30	A38030612019	* Washer (M6) .....	1	66	180109000	Small Sponge .....	1
31	979824001	Stopper .....	1	67	8180A21000	Transformer Board Assembly .....	1
32	979825001	Spring Pin (M5 x 10 mm) .....	1	68	180107000	Medium Sponge .....	1
35	180111000	Rubber Feet .....	4	69	180311000	Blade Drawn Bracket .....	1
36	180113000	Base .....	1	70	180607000	Foot Switch .....	1

\* STANDARD HARDWARE ITEM – MAY BE PURCHASED LOCALLY

CRAFTSMAN 18 in. (457 mm) SCROLL SAW – MODEL NO. 216090

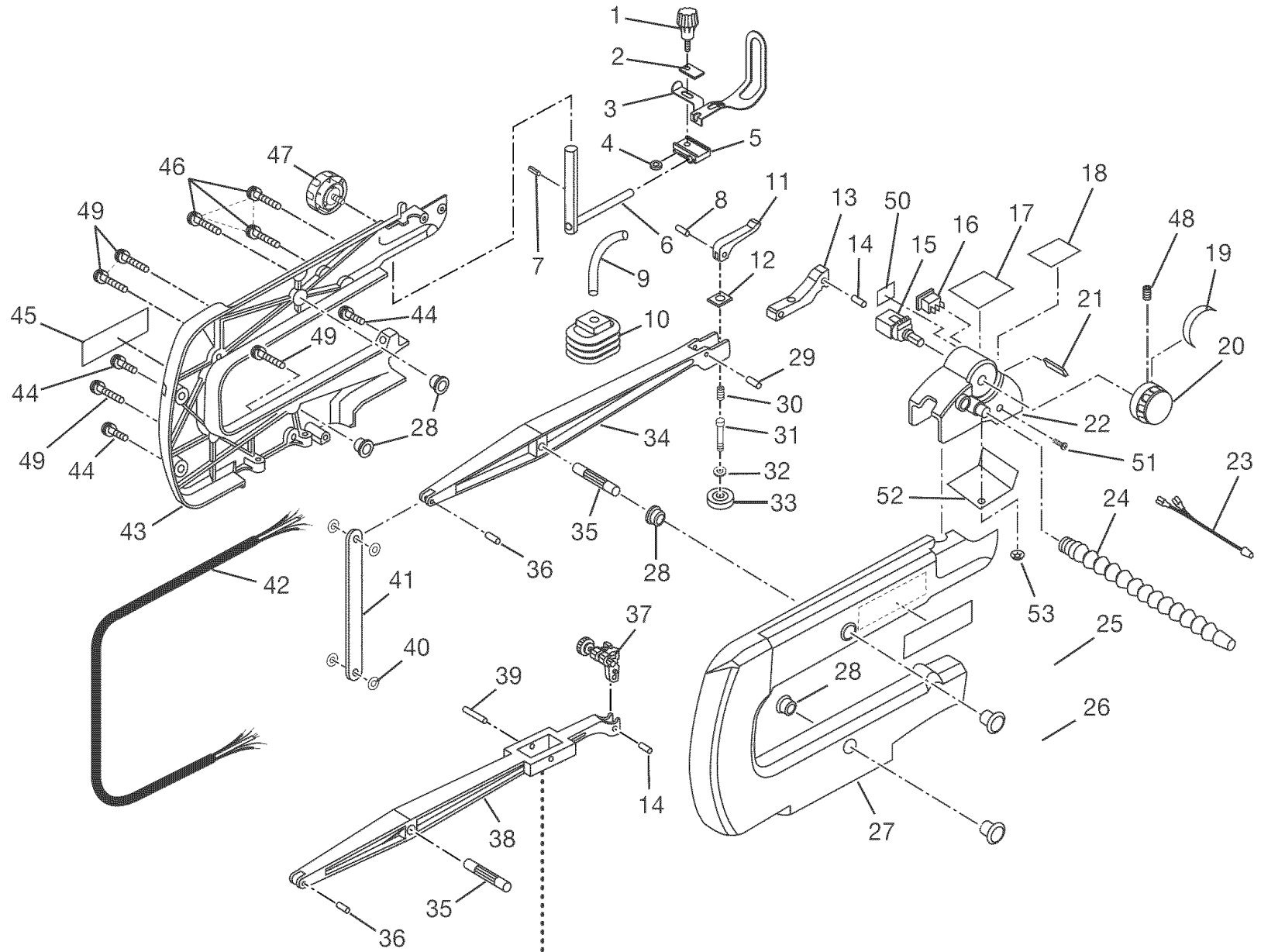

26

SEE FIGURE A

FIGURE B

**CRAFTSMAN 18 in. (457 mm) SCROLL SAW – MODEL NO. 216090**

The model number will be found on a plate attached to the motor housing. Always mention the model number in all correspondence regarding your **Scroll Saw** or when ordering repair parts.

**SEE BACK PAGE FOR PARTS ORDERING INSTRUCTIONS**

**PARTS LIST FOR FIGURE B**

KEY NO.	PART NUMBER	DESCRIPTION	QTY.	KEY NO.	PART NUMBER	DESCRIPTION	QTY.
1	102032002	Tension Adjusting Knob .....	1	29	A41001052340	Spring Pin (M5 x 23.4 mm) .....	1
2	979745001	Support Plate .....	1	30	180215000	Spring.....	1
3	979747001	Drop Foot.....	1	31	180205000	Adjustment Screw.....	1
4	180243000	Washer (M5).....	1	32	A35030616160 *	Washer (M6).....	1
5	979749001	Hold Down Clamp.....	1	33	180254000	Tension Knob .....	1
6	180a04010	Support Bar Assembly.....	1	34	180201000	Upper Arm.....	1
7	A42001030109	Spring Pin (M3 x 10 mm) .....	1	35	180223000	Bearing.....	2
8	A42001030140	Spring Pin (M3 x 14 mm) .....	1	36	A42001050220	Spring Pin (M5 x 22 mm) .....	2
9	180232000	Bellow .....	1	37	180a02040	Lower Clamp Assembly .....	1
10	108217000	Blower.....	1	38	180212000	Lower Arm.....	1
11	180253000	Blade Tension Lever.....	1	39	180240000	Pin .....	1
12	180210000	Washer .....	1	40	180248000	Washer .....	4
13	180204000	Bracket.....	1	41	180211000	Link .....	1
14	A41001050150	Pin (M5 x 15 mm).....	2	42	180a02070	Lead Wire Assembly .....	1
15	8000200011	Vr Switch.....	1	43	180252000	Right Arm Cover .....	1
16	180226000	Switch .....	1	44	A11003040255 *	Screw (M4 x 25) .....	3
17	180259000	Switch Label .....	1	45	180114000	Warning Label .....	1
18	180258000	Warning Label .....	1	46	A11003040350 *	Screw (M4 x 35) .....	3
19	180260000	On/Off Knob Label .....	1	47	180251000	Drop Foot Lock Knob .....	1
20	180255000	On/Off Knob.....	1	48	A95001050120	Set Screw (M5 x 12 mm).....	1
21	166102100	Motor Pointer .....	1	49	A11003040400	Screw, Ph. Hd. (M4 x 40 mm + S).....	4
22	180219000	Switch Cover.....	1	50	180262000	Led Label .....	1
23	180229000	Led .....	1	51	A10003040107	Screw, Ph. Hd. (M4 x 10 mm) .....	4
24	180a02060	Sawdust Blower/Light.....	1	52	180244000	Spacer.....	1
25	180261000	Logo Plate.....	2	53	180245000	Retaining Ring (K7) .....	1
26	979829001	Rubber Stopper .....	4		983000769	Operator's Manual	
27	180256000	Left Arm Cover.....	1		04-12-05		
28	979765001	Bearing Bushing.....	4				

\* STANDARD HARDWARE ITEM – MAY BE PURCHASED LOCALLY

# Get it fixed, at your home or ours!

## Your Home

For repair – **in your home** – of **all** major brand appliances, lawn and garden equipment, or heating and cooling systems, **no matter who made it, no matter who sold it!**

For the replacement parts, accessories and owner's manuals that you need to do-it-yourself.

For Sears professional installation of home appliances and items like garage door openers and water heaters.

**1-800-4-MY-HOME® (1-800-469-4663)**

Call anytime, day or night (U.S.A. and Canada)

[www.sears.com](http://www.sears.com)    [www.sears.ca](http://www.sears.ca)

---

## Our Home

For repair of carry-in items like vacuums, lawn equipment, and electronics, call or go on-line for the location of your nearest **Sears Parts & Repair Center.**

**1-800-488-1222**

Call anytime, day or night (U.S.A. only)

[www.sears.com](http://www.sears.com)

---

To purchase a protection agreement (U.S.A.) or maintenance agreement (Canada) on a product serviced by Sears:

**1-800-827-6655** (U.S.A.)

**1-800-361-6665** (Canada)

---

Para pedir servicio de reparación a domicilio, y para ordenar piezas:

**1-888-SU-HOGAR<sup>SM</sup>**

(1-888-784-6427)

Au Canada pour service en français:

**1-800-LE-FOYER<sup>MC</sup>**

(1-800-533-6937)

[www.sears.ca](http://www.sears.ca)



## Free Manuals Download Website

<http://myh66.com>

<http://usermanuals.us>

<http://www.somanuals.com>

<http://www.4manuals.cc>

<http://www.manual-lib.com>

<http://www.404manual.com>

<http://www.luxmanual.com>

<http://aubethermostatmanual.com>

Golf course search by state

<http://golfingnear.com>

Email search by domain

<http://emailbydomain.com>

Auto manuals search

<http://auto.somanuals.com>

TV manuals search

<http://tv.somanuals.com>