

Owner's Manual

CRAFTSMAN®

**20.0 HP
ELECTRIC START
46" MOWER
AUTOMATIC
GARDEN TRACTOR**

EZ³

Model No.
917.272960

- Safety
- Assembly
- Operation
- Maintenance
- Repair Parts

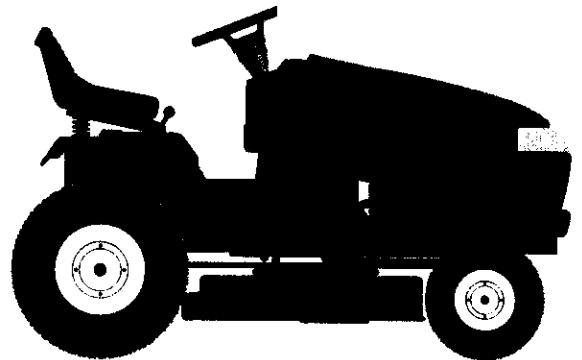

This product has a low emission engine which operates differently from previously built engines. Before you start the engine, read and understand this Owner's Manual.

CAUTION:
Read and follow all Safety Rules and Instructions before operating this equipment.

For answers to your questions about this product, Call:
1-800-659-5917
Sears Craftsman Help Line
5 am - 5 pm, Mon - Sat

Sears, Roebuck and Co., Hoffman Estates, IL 60179
Visit our Craftsman website: www.sears.com/craftsman

TABLE OF CONTENTS

Warranty	2	Maintenance	19
Safety Rules	3	Service and Adjustments.....	23
Product Specifications	5	Storage	31
Assembly	7	Troubleshooting	32
Operation	12	Repair Parts	36
Maintenance Schedule	19	Parts Ordering	Back Cover

WARRANTY

LIMITED TWO YEAR WARRANTY ON CRAFTSMAN RIDING EQUIPMENT PARTS

For two (2) years from the date of purchase, if this Craftsman Riding Equipment is maintained, lubricated and tuned up according to the instructions in the owner's manual, Sears will repair or replace, free of charge, any parts found to be defective in material or workmanship. Warranty service is available free of charge by taking your Craftsman riding equipment to your nearest Sears Service Center. In-home warranty service is available but a trip charge will apply. This warranty applies only while this product is in the United States.

This Warranty does not cover:

- Expendable items which become worn during normal use, such as blades, spark plugs, air cleaners, belts and oil filters.
- Tire replacement or repair caused by punctures from outside objects, such as nails, thorns, stumps, or glass.
- Repairs necessary because of operator abuse, including but not limited to, damage caused by towing objects beyond the capability of the riding equipment, impacting objects that bend the frame or crankshaft, or over speeding the engine.
- Repairs necessary because of operator negligence, including but not limited to, electrical and mechanical damage caused by improper storage, failure to use the proper grade and amount of engine oil, failure to keep the deck clear of flammable debris, or the failure to maintain the equipment according to the instructions contained in the owner's manual.
- Engine (fuel system) cleaning or repairs caused by fuel determined to be contaminated or oxidized (stale). In general, fuel should be used within thirty (30) days of its purchase date.
- Riding equipment used for commercial or rental purposes.

LIMITED 90 DAY WARRANTY ON BATTERY

For ninety (90) days from date of purchase, if any battery included with this riding equipment proves defective in material or workmanship and our testing determines the battery will not hold a charge, Sears will replace the battery at no charge. Warranty service is available free of charge by taking your Craftsman riding equipment to your nearest Sears Service Center. In-home warranty service is available but a trip charge will apply. This warranty applies only while this product is in the United States.

To locate the nearest sears service center or to schedule in-home warranty service, simply contact sears at 1-800-4-my-home

This Warranty gives you specific legal rights, and you may also have other rights which may vary from state to state.

Sears, Roebuck and Co., D/817 WA, Hoffman Estates, IL 60179

SAFETY RULES

IMPORTANT: This cutting machine is capable of amputating hands and feet and throwing objects. Failure to observe the following safety instructions could result in serious injury or death.

GENERAL OPERATION

- Read, understand, and follow all instructions in the manual and on the machine before starting.
- Only allow responsible adults, who are familiar with the instructions, to operate the machine.
- Clear the area of objects such as rocks, toys, wire, etc., which could be picked up and thrown by the blade.
- Be sure the area is clear of other people before mowing. Stop machine if anyone enters the area.
- Never carry passengers.
- Do not mow in reverse unless absolutely necessary. Always look down and behind before and while backing.
- Be aware of the mower discharge direction and do not point it at anyone. Do not operate the mower without either the entire grass catcher or the guard in place.
- Slow down before turning.
- Never leave a running machine unattended. Always turn off blades, set parking brake, stop engine, and remove keys before dismounting.
- Turn off blades when not mowing.
- Stop engine before removing grass catcher or unclogging chute.
- Mow only in daylight or good artificial light.
- Do not operate the machine while under the influence of alcohol or drugs.
- Watch for traffic when operating near or crossing roadways.
- Use extra care when loading or unloading the machine into a trailer or truck.
- Data indicates that operators, age 60 years and above, are involved in a large percentage of riding mower-related injuries. These operators should evaluate their ability to operate the riding mower safely enough to protect themselves and others from serious injury.

SLOPE OPERATION

Slopes are a major factor related to loss-of-control and tipover accidents, which

can result in severe injury or death. All slopes require extra caution. If you cannot back up the slope or if you feel uneasy on it, do not mow it.

DO:

- Mow up and down slopes, not across.
- Remove obstacles such as rocks, tree limbs, etc.
- Watch for holes, ruts, or bumps. Uneven terrain could overturn the machine. Tall grass can hide obstacles.
- Use slow speed. Choose a low gear so that you will not have to stop or shift while on the slope.
- Follow the manufacturer's recommendations for wheel weights or counterweights to improve stability.
- Use extra care with grass catchers or other attachments. These can change the stability of the machine.
- Keep all movement on the slopes slow and gradual. Do not make sudden changes in speed or direction.
- Avoid starting or stopping on a slope. If tires lose traction, disengage the blades and proceed slowly straight down the slope.

DO NOT:

- *Do not* turn on slopes unless necessary, and then, turn slowly and gradually downhill, if possible.
- *Do not* mow near drop-offs, ditches, or embankments. The mower could suddenly turn over if a wheel is over the edge of a cliff or ditch, or if an edge caves in.
- *Do not* mow on wet grass. Reduced traction could cause sliding.
- *Do not* try to stabilize the machine by putting your foot on the ground.
- *Do not* use grass catcher on steep slopes.

CHILDREN

Tragic accidents can occur if the operator is not alert to the presence of children. Children are often attracted to the machine and the mowing activity. *Never* assume that children will remain where you last saw them.

- Keep children out of the mowing area and under the watchful care of another responsible adult.
- Be alert and turn machine off if children enter the area.

SAFETY RULES

- Before and when backing, look behind and down for small children.
- Never carry children. They may fall off and be seriously injured or interfere with safe machine operation.
- Never allow children to operate the machine.
- Use extra care when approaching blind corners, shrubs, trees, or other objects that may obscure vision.

SERVICE

- Use extra care in handling gasoline and other fuels. They are flammable and vapors are explosive.
 - Use only an approved container.
 - Never remove gas cap or add fuel with the engine running. Allow engine to cool before refueling. Do not smoke.
 - Never refuel the machine indoors.
 - Never store the machine or fuel container inside where there is an open flame, such as a water heater.
- Never run a machine inside a closed area.
- Keep nuts and bolts, especially blade attachment bolts, tight and keep equipment in good condition.

- Never tamper with safety devices. Check their proper operation regularly.
- Keep machine free of grass, leaves, or other debris build-up. Clean oil or fuel spillage. Allow machine to cool before storing.
- Stop and inspect the equipment if you strike an object. Repair, if necessary, before restarting.
- Never make adjustments or repairs with the engine running.
- Grass catcher components are subject to wear, damage, and deterioration, which could expose moving parts or allow objects to be thrown. Frequently check components and replace with manufacturer's recommended parts, when necessary.
- Mower blades are sharp and can cut. Wrap the blade(s) or wear gloves, and use extra caution when servicing them.
- Check brake operation frequently. Adjust and service as required.



- Be sure the area is clear of other people before mowing. Stop machine if anyone enters the area.
- Never carry passengers or children even with the blades off.
- Do not mow in reverse unless absolutely necessary. Always look down and behind before and while backing.
- Never carry children. They may fall off and be seriously injured or interfere with safe machine operation.
- Keep children out of the mowing area and under the watchful care of another responsible adult.
- Be alert and turn machine off if children enter the area.
- Before and when backing, look behind and *down* for small children.
- Mow up and down slopes (15° Max), not across.
- Remove obstacles such as rocks, tree limbs, etc.
- Watch for holes, ruts, or bumps. Uneven terrain could overturn the machine. *Tall grass can hide obstacles.*
- Use slow speed. Choose a low gear so that you will not have to stop or shift while on the slope.
- Avoid starting or stopping on a slope. If tires lose traction, disengage the blades and proceed slowly *straight* down the slope.
- If machine stops while going uphill, disengage blades, shift into reverse and back down slowly.
- *Do not* turn on slopes unless necessary, and then, turn slowly and gradually downhill, if possible.

SAFETY RULES

⚠ Look for this symbol to point out important safety precautions. It means **CAUTION!!! BECOME AWARE!!! YOUR SAFETY IS INVOLVED.**

⚠ CAUTION: In order to prevent accidental starting when setting up, transporting, adjusting or making repairs always disconnect spark plug wire and place wire where it cannot contact spark plug.

⚠ CAUTION: Do not coast down a hill in neutral, you may lose control of the tractor.

⚠ CAUTION: Tow only the attachments that are recommended by and comply with specifications of the manufacturer of your tractor. Use common sense when towing. Operate only at the lowest possible speed when on a slope. Too heavy of a load, while on a slope, is dangerous. Tires can lose traction with the ground and cause you to lose control of your tractor.

⚠ WARNING: The engine exhaust from this product contains chemicals known to the State of California to cause cancer, birth defects, or other reproductive harm.

PRODUCT SPECIFICATIONS

GASOLINE CAPACITY AND TYPE:	3.5 GALLONS UNLEADED REGULAR
OIL TYPE (API-SF/SG/SH):	SAE 10W30 (ABOVE 32°F) SAE 5W-30 (BELOW 32°F)
OIL CAPACITY:	W/FILTER: 4.5PINTS W/O FILTER: 4.0PINTS
SPARK PLUG: (GAP: .030")	CHAMPION RC12YC
GROUND SPEED (MPH):	FORWARD: 5.8 REVERSE: 2.1
TIRE PRESSURE:	FRONT: 14 PSI REAR: 10 PSI
CHARGING SYSTEM:	15AMPS @ 3600RPM
BATTERY:	AMP/HR: 35 MIN. CCA: 280 CASE SIZE: U1R
BLADE BOLT TORQUE:	27-35 FT. LBS

CONGRATULATIONS on your purchase of a new Tractor. It has been designed, engineered and manufactured to give you the best possible dependability and performance.

Should you experience any problem you cannot easily remedy, please contact your nearest authorized service center/department. We have competent, well-trained technicians and the proper tools to service or repair this tractor.

Please read and retain this manual. The instructions will enable you to assemble and maintain your tractor properly. Always observe the "SAFETY RULES".

REPAIR AGREEMENT

A Repair Agreement is available on this product. Contact your nearest Sears store for details.

CUSTOMER RESPONSIBILITIES

- Read and observe the safety rules.
- Follow a regular schedule in maintaining, caring for and using your tractor.
- Follow the instructions under "Maintenance" and "Storage" sections of this owner's manual.

⚠ WARNING: This tractor is equipped with an internal combustion engine and should not be used on or near any unimproved forest-covered, brush-covered or grass-covered land unless the engine's exhaust system is equipped with a spark arrester meeting applicable local or state laws (if any). If a spark arrester is used, it should be maintained in effective working order by the operator.

In the state of California the above is required by law (Section 4442 of the California Public Resources Code). Other states may have similar laws. Federal laws apply on federal lands. A spark arrester for the muffler is available through your nearest authorized service center/department (See REPAIR PARTS

UNASSEMBLED PARTS

Steering Wheel



Steering
Wheel Insert

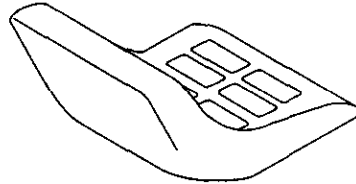
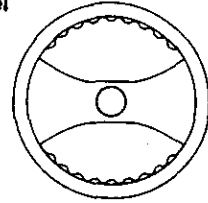

Seat

(1) Washer
17/32 x 1-3/16 x 12 Gauge

(1) Knob

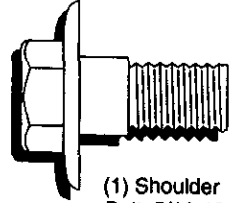

(1) Shoulder
Bolt 5/16-18

Mower

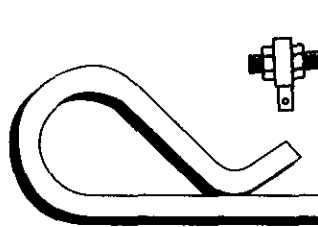

(4) Retainer Springs (single loop)

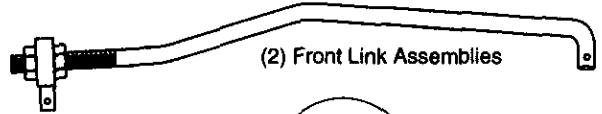

(2) Front Link Assemblies



(3) Retainer Springs (double loop)

Gauge Wheels

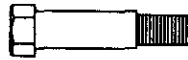

(2) Shoulder
Bolts

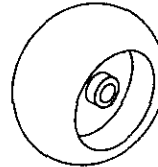

(2) Gauge
Wheels



(2) Washers 3/8
x 7/8 x 14 Gauge



(2) Center-
lock Nuts

UNASSEMBLED PARTS

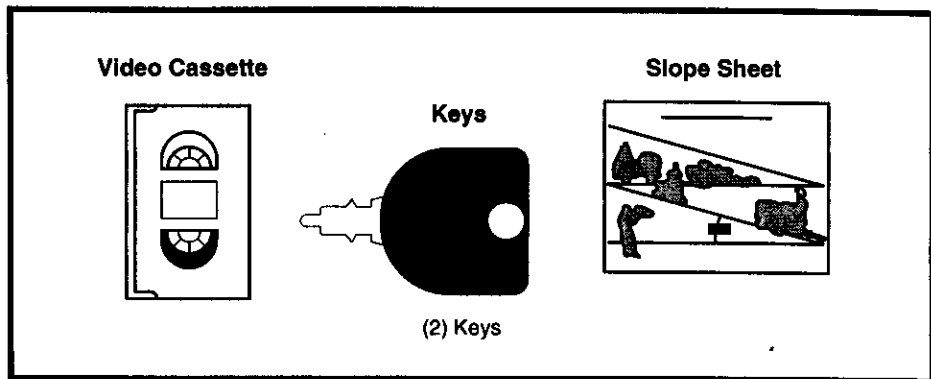

ASSEMBLY

Your new tractor has been assembled at the factory with exception of those parts left unassembled for shipping purposes. To ensure safe and proper operation of your tractor all parts and hardware you assemble must be tightened securely. Use the correct tools as necessary to insure proper tightness. Review the video cassette before you begin.

TOOLS REQUIRED FOR ASSEMBLY

A socket wrench set will make assembly easier. Standard wrench sizes you need are listed below.

- | | |
|---------------------------------------|-------------------|
| (1) 9/16" wrench | (1) Pliers |
| (1) 1/2" wrench | (1) Utility knife |
| (1) 3/4" socket with
drive ratchet | |
| (1) Tire pressure gauge | |

When right or left hand is mentioned in this manual, it means, from your point of view, when you are in the operating position (seated behind the steering wheel).

TO REMOVE TRACTOR FROM CARTON

UNPACK CARTON

- Remove all accessible loose parts and parts boxes from shipping carton.
- Cut, from top to bottom, along lines on all four corners of shipping carton, and lay panels flat.
- Remove mower and packing materials.
- Check for any additional loose parts or boxes and remove.

BEFORE REMOVING TRACTOR OFF SKID

ATTACH STEERING WHEEL

- Remove hex bolt, lock washer and large flat washer from steering shaft.
- Position front wheels of the tractor so they are pointing straight forward.
- Slide the steering sleeve over the steering shaft.
- Position steering wheel so cross bars are horizontal (left to right) and slide onto steering wheel adapter.
- Secure steering wheel to steering shaft with hex bolt, lock washer and large flat washer previously removed. Tighten securely.
- Snap steering wheel insert into center of steering wheel.
- Remove protective materials from tractor hood and grill.

IMPORTANT: Check for and remove any staples in skid that may puncture tires where tractor is to roll off skid.

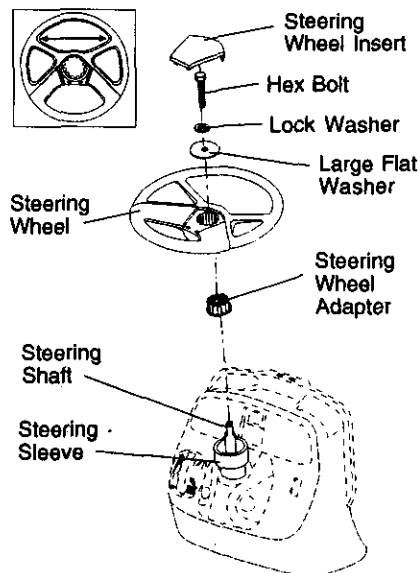

HOW TO SET UP YOUR TRACTOR CHECK BATTERY

- Lift hood to raised position.
- If this battery is put into service after month and year indicated on label (label located between terminals) charge battery for minimum of one hour at 6-10 amps. (See "BATTERY" in Maintenance section of this manual for charging instructions).

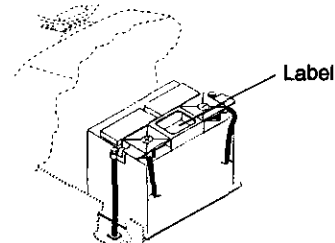

INSTALL SEAT

Adjust seat before tightening adjustment knob.

- Remove adjustment knob and flat washer securing seat to cardboard packing and set aside for assembly of seat to tractor.
- Pivot seat upward and remove from the cardboard packing. Remove the cardboard packing and discard.
- Place seat on seat pan and assemble shoulder bolt. Tighten shoulder bolt securely.
- Assemble adjustment knob and flat washer loosely. Do not tighten.
- Lower seat into operating position and sit on seat.
- Slide seat until a comfortable position is reached which allows you to press clutch/brake pedal all the way down.
- Get off seat without moving its adjusted position.
- Raise seat and tighten adjustment knob securely.

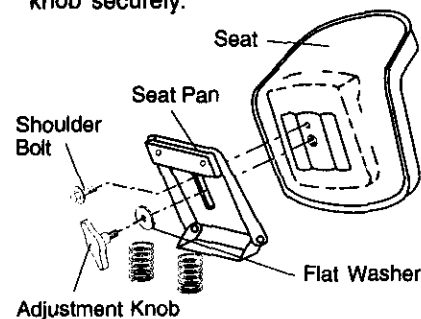

NOTE: You may now roll or drive your tractor off the skid. Follow the appropriate instruction below to remove the tractor from the skid.

TO ROLL TRACTOR OFF SKID (See Operation section for location and function of controls)

- Press lift lever plunger and raise attachment lift lever to its highest position.
- Release parking brake by depressing clutch/brake pedal.
- Place freewheel control in freewheeling position to disengage transmission (See "TO TRANSPORT" in the Operation section of this manual).
- Roll tractor forward off skid.

TO DRIVE TRACTOR OFF SKID (See Operation section for location and function of controls)

⚠ WARNING: Before starting, read, understand and follow all instructions in the Operation section of this manual. Be sure tractor is in a well-ventilated area. Be sure the area in front of tractor is clear of other people and objects.

- Be sure all the above assembly steps have been completed.
- Check engine oil level and fill fuel tank with gasoline.
- Place freewheel control in "transmission engaged" position.

- Sit on seat in operating position, depress clutch/brake pedal and set the parking brake.
 - Place motion control lever in neutral (N) position.
 - Press lift lever plunger and raise attachment lift lever to its highest position.
 - Start the engine. After engine has started, move throttle control to idle position.
 - Release parking brake.
 - Slowly move the motion control lever forward and slowly drive tractor off skid.
 - Apply brake to stop tractor, set parking brake and place gearshift lever in neutral position.
 - Turn ignition key to "OFF" position.
- Continue with the instructions that follow.

INSTALL MOWER AND DRIVE BELT

Be sure tractor is on level surface and mower suspension arms are raised with attachment lift control. Engage parking brake.

- Cut and remove ties securing anti-sway bar and belts. Swing anti-sway bar to left side of mower deck.
- Slide mower under tractor with discharge guard to right side of tractor.

IMPORTANT: Check belt for proper routing in all mower pulley grooves. Install belt into electric clutch pulley groove.

- Install one front link in top hole of the R.H. front mower bracket and R.H. front suspension bracket. Retain with two single loop retainer springs as shown.
- Install second front link in L.H. front suspension bracket only and retain with single loop retainer spring as shown.
- Turn height adjustment knob counter-clockwise until it stops.
- Lower mower linkage with attachment lift control.
- Place the L.H. suspension arm on inward pointing deck pin. If necessary, rock and raise front of mower to align deck pin with the hole in suspension arm. Retain with double loop retainer spring with loops down as shown.
- Slide left side of mower back and install the unattached front link in top hole of the L.H. front mower bracket. Retain with single loop retainer spring as shown.
- Place the R.H. suspension arm on inward pointing deck pin. If necessary, rock and raise front of mower to align deck pin with the hole in suspension arm. Retain with double loop retainer spring with loops down as shown.
- Connect anti-sway bar to chassis bracket under left footrest and retain with double loop retainer spring.

- Turn height adjustment knob clockwise to remove slack from mower suspension.
- Raise mower to highest position.
- Assemble gauge wheels (See "TO ADJUST GAUGE WHEELS" in the Operation section of this manual).

CHECK TIRE PRESSURE

The tires on your tractor were overinflated at the factory for shipping purposes. Correct tire pressure is important for best cutting performance.

- Reduce tire pressure to PSI shown in "PRODUCT SPECIFICATIONS" section of this manual.

CHECK MOWER LEVELNESS

For best cutting results, mower should be properly leveled. See "TO LEVEL MOWER HOUSING" in the Service and Adjustments section of this manual.

CHECK FOR PROPER POSITION OF ALL BELTS

See the figures that are shown for replacing motion, mower drive, and mower blade drive belts in the Service and Adjustments section of this manual. Verify that the belts are routed correctly.

CHECK BRAKE SYSTEM

After you learn how to operate your tractor, check to see that the brake is properly adjusted. See "TO ADJUST BRAKE" in the Service and Adjustments section of this manual.

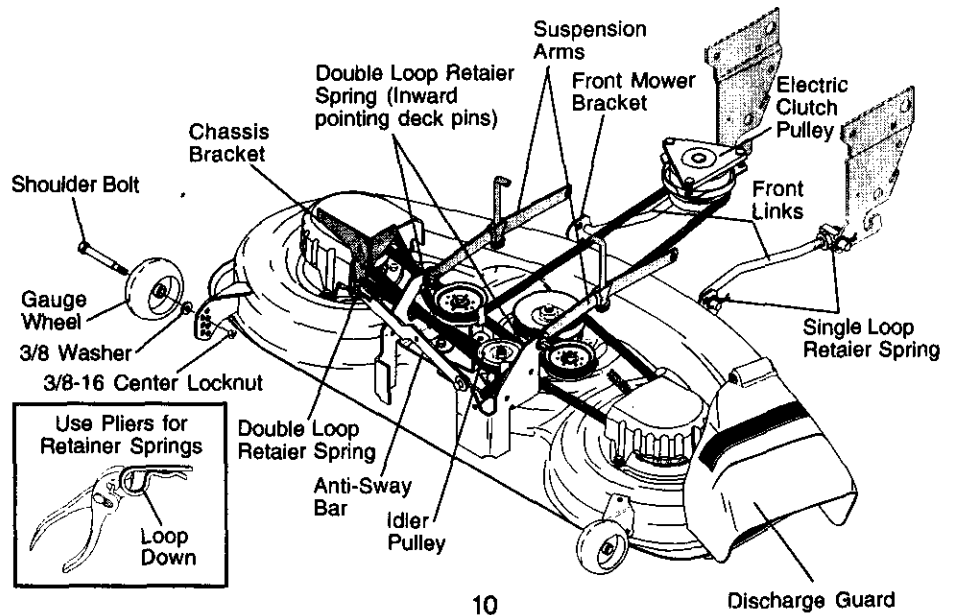

✓CHECKLIST

BEFORE YOU OPERATE AND ENJOY YOUR NEW TRACTOR, WE WISH TO ASSURE THAT YOU RECEIVE THE BEST PERFORMANCE AND SATISFACTION FROM THIS QUALITY PRODUCT.

PLEASE REVIEW THE FOLLOWING CHECKLIST:

- ✓ All assembly instructions have been completed.
- ✓ No remaining loose parts in carton.
- ✓ Battery is properly prepared and charged. (Minimum 1 hour at 6 amps).
- ✓ Seat is adjusted comfortably and tightened securely.
- ✓ All tires are properly inflated. (For shipping purposes, the tires were overinflated at the factory).
- ✓ Be sure mower deck is properly leveled side-to-side/front-to-rear for best cutting results. (Tires must be properly inflated for leveling).
- ✓ Check mower and drive belts. Be sure they are routed properly around pulleys and inside all belt keepers.
- ✓ Check wiring. See that all connections are still secure and wires are properly clamped.
- ✓ Before driving tractor, be sure free-wheel control is in drive position.

WHILE LEARNING HOW TO USE YOUR TRACTOR, PAY EXTRA ATTENTION TO THE FOLLOWING IMPORTANT ITEMS:

- ✓ Engine oil is at proper level.
- ✓ Fuel tank is filled with fresh, clean, regular unleaded gasoline.
- ✓ Become familiar with all controls - their location and function. Operate them before you start the engine.
- ✓ Be sure brake system is in safe operating condition.
- ✓ It is important to purge the transmission before operating your tractor for the first time. Follow proper starting and transmission purging instructions (See "TO START ENGINE" and "PURGE TRANSMISSION" in the Operation section of this manual).

OPERATION

These symbols may appear on your tractor or in literature supplied with the product. Learn and understand their meaning.



BATTERY



CAUTION OR WARNING



REVERSE



FORWARD



FAST



SLOW



ENGINE ON



ENGINE OFF



OIL PRESSURE



LIGHTS ON



OVER TEMP LIGHT



MOWER LIFT



FUEL



CHOKE



MOWER HEIGHT



PARKING BRAKE LOCKED



UNLOCKED



MOWER LIFT



ATTACHMENT CLUTCH ENGAGED



REVERSE



NEUTRAL



HIGH



LOW



PARKING BRAKE



IGNITION



ATTACHMENT CLUTCH DISENGAGED



KEEP AREA CLEAR



SLOPE HAZARDS

(SEE SAFETY RULES SECTION)



DANGER, KEEP HANDS AND FEET AWAY

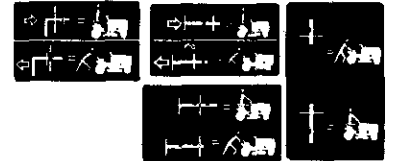

FREE WHEEL
(Automatic Models only)

KNOW YOUR TRACTOR

READ THIS OWNER'S MANUAL AND SAFETY RULES BEFORE OPERATING YOUR TRACTOR

Compare the illustrations with your tractor to familiarize yourself with the locations of various controls and adjustments. Save this manual for future reference.

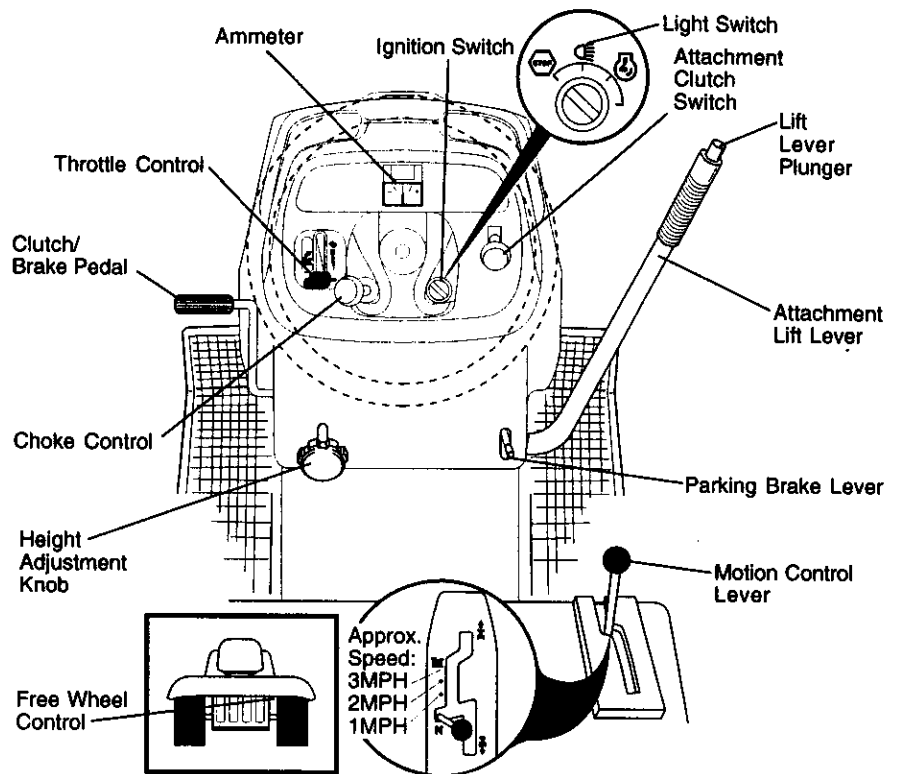

Our tractors conform to the safety standards of the American National Standards Institute.

ATTACHMENT CLUTCH SWITCH - Used to engage the mower blades, or other attachments mounted to your tractor.

LIGHT SWITCH - Turns the headlights on and off.

THROTTLE CONTROL - Used to control engine speed.

CLUTCH/BRAKE PEDAL - Used for declutching and braking the tractor and starting the engine.

CHOKE CONTROL - Used when starting a cold engine.

HEIGHT ADJUSTMENT KNOB - Used to adjust the mower cutting height.

IGNITION SWITCH - Used for starting and stopping the engine.

ATTACHMENT LIFT LEVER - Used to raise, lower, and adjust the mower deck or other attachments mounted to your tractor.

LIFT LEVER PLUNGER - Used to release attachment lift lever when changing its position.

AMMETER - Indicates charging (+) or discharging (-) of battery.

PARKING BRAKE LEVER - Locks clutch/brake pedal into the brake position.

MOTION CONTROL LEVER - Selects the speed and direction of tractor.

FREEWHEEL CONTROL - Disengages transmission for pushing or slowly towing the tractor with the engine off.



The operation of any tractor can result in foreign objects thrown into the eyes, which can result in severe eye damage. Always wear safety glasses or eye shields while operating your tractor or performing any adjustments or repairs. We recommend a wide vision safety mask over spectacles or standard safety glasses.

HOW TO USE YOUR TRACTOR TO SET PARKING BRAKE

Your tractor is equipped with an operator presence sensing switch. When engine is running, any attempt by the operator to leave the seat without first setting the parking brake will shut off the engine.

- Depress clutch/brake pedal into full "BRAKE" position and hold.
- Place parking brake lever in "ENGAGED" position and release pressure from clutch/brake pedal. Pedal should remain in "BRAKE" position. Make sure parking brake will hold tractor secure.

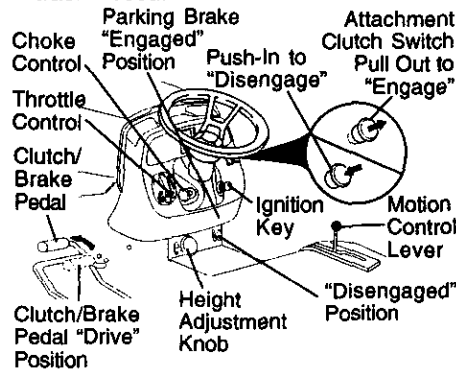

STOPPING

MOWER BLADES -

- To stop mower blades, move attachment clutch switch to "DISENGAGED" position.

GROUND DRIVE -

- To stop ground drive, depress clutch/brake pedal into full "BRAKE" position.
- Move motion control lever to neutral (N) position.

IMPORTANT: The motion control lever does not return to neutral (N) position when the clutch/brake pedal is depressed.

ENGINE -

- Move throttle control to slow position.
- NOTE:** Failure to move throttle control to slow position and allowing engine to idle before stopping may cause engine to "backfire".
- Turn ignition key to "OFF" position and remove key. Always remove key when leaving tractor to prevent unauthorized use.

- Never use choke to stop engine.
- IMPORTANT:** Leaving the ignition switch in any position other than "OFF" will cause the battery to be discharged (dead).

NOTE: Under certain conditions when tractor is standing idle with the engine running, hot engine exhaust gases may cause "browning" of grass. To eliminate this possibility, always stop engine when stopping tractor on grass areas.

CAUTION: Always stop tractor completely, as described above, before leaving the operator's position; to empty grass catcher, etc.

TO USE THROTTLE CONTROL

- Always operate engine at full throttle.
- Operating engine at less than full throttle reduces the battery charging rate.
 - Full throttle offers the best bagging and mower performance.

TO USE CHOKE CONTROL

Use choke control whenever you are starting a cold engine. Do not use to start a warm engine.

- To engage choke control, pull knob out. Slowly push knob in to disengage.

TO MOVE FORWARD AND BACKWARD

The direction and speed of movement is controlled by the motion control lever.

- Start tractor with motion control lever in neutral (N) position.
- Release parking brake and clutch/brake pedal.
- Slowly move motion control lever to desired position.

TO ADJUST MOWER CUTTING HEIGHT

The cutting height is controlled by turning the height adjustment knob in desired direction.

- Turn knob clockwise (↻) to raise cutting height.
- Turn knob counterclockwise (↺) to lower cutting height.

The cutting height range is approximately 1-1/2" to 4". The heights are measured from the ground to the blade tip with the engine not running. These heights are approximate and may vary depending upon soil conditions, height of grass and types of grass being mowed.

- The average lawn should be cut to approximately 2-1/2 inches during the cool season and to over 3 inches during hot months. For healthier and better looking lawns, mow often and after moderate growth.
- For best cutting performance, grass over 6 inches in height should be mowed twice. Make the first cut relatively high; the second to desired height.

TO ADJUST GAUGE WHEELS

Gauge wheels are properly adjusted when they are slightly off the ground when mower is at the desired cutting height in operating position. Gauge wheels then keep the deck in proper position to help prevent scalping in most terrain conditions.

- Adjust gauge wheels with tractor on a flat level surface.
- Adjust mower to desired cutting height (See "TO ADJUST MOWER CUTTING HEIGHT" in the Operation section of this manual).
- With mower in desired height of cut position, gauge wheels should be assembled so they are slightly off the ground. Install gauge wheel in appropriate hole with shoulder bolt, 3/8 washer, and 3/8-16 locknut and tighten securely.
- Repeat for opposite side installing gauge wheel in same adjustment hole.

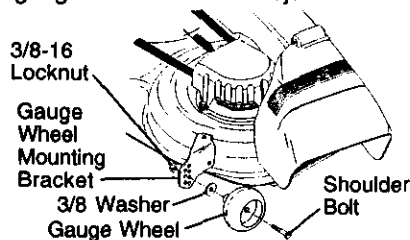

TO OPERATE MOWER

Your tractor is equipped with an operator presence sensing switch. Any attempt by the operator to leave the seat with the engine running and the attachment clutch engaged will shut off the engine.

- Select desired height of cut.
- Lower mower with attachment lift control.
- Start mower blades by engaging attachment clutch control.
- TO STOP MOWER BLADES - disengage attachment clutch control.

CAUTION: Do not operate the mower without either the entire grass catcher, on mowers so equipped, or the discharge guard in place.

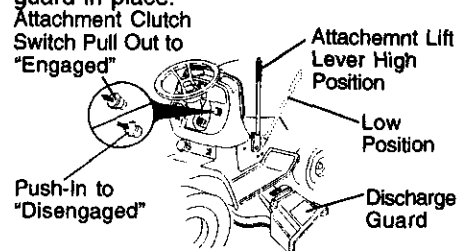

TO OPERATE ON HILLS

CAUTION: Do not drive up or down hills with slopes greater than 15° and do not drive across any slope.

- Choose the slowest speed before starting up or down hills.
 - Avoid stopping or changing speed on hills.
 - If slowing is necessary, move throttle control lever to slower position.
 - If stopping is absolutely necessary, push clutch/brake pedal quickly to brake position and engage parking brake.
 - Move motion control lever to slowest setting.
- IMPORTANT:** The motion control lever does not return to neutral (N) position when the clutch/brake pedal is depressed.
- To restart movement, slowly release parking brake and clutch/brake pedal.
 - Slowly move motin control lever to slowest setting.
 - Make all turns slowly.

TO TRANSPORT

When pushing or towing your tractor, be sure to disengage transmission by placing freewheel control in freewheeling position. Free wheel control is located at the rear drawbar of tractor.

- Raise attachment lift to highest position with attachment lift control.
- Remove retainer spring from free-wheel control rod.
- Push control rod in to disengage transmission and reinsert retainer spring into control rod hole now on back side of the bracket.

- Do not push or tow tractor at more than two (2) MPH.
- To reengage transmission, reverse above procedure.

NOTE: To protect hood from damage when transporting your tractor on a truck or a trailer, be sure hood is closed and secured to tractor. Use an appropriate means of tying hood to tractor (rope, cord, etc.).

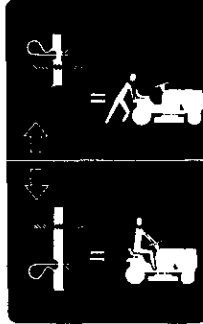

TOWING CARTS AND OTHER ATTACHMENTS

Tow only the attachments that are recommended by and comply with specifications of the manufacturer of your tractor. Use common sense when towing. Too heavy of a load, while on a slope, is dangerous. Tires can lose traction with the ground and cause you to lose control of your tractor.

BEFORE STARTING THE ENGINE

CHECK ENGINE OIL LEVEL

- The engine in your tractor has been shipped, from the factory, already filled with summer weight oil.
- Check engine oil with tractor on level ground.
- Unthread and remove oil fill cap/dipstick; wipe oil off. Reinsert the dipstick into the tube and rest oil fill cap on the tube. Do not thread the cap onto the tube. Remove and read oil level. If necessary, add oil until "FULL" mark on dipstick is reached. Do not overfill.
- For cold weather operation you should change oil for easier starting (See "OIL VISCOSITY CHART" in the Maintenance section of this manual).
- To change engine oil, see the Maintenance section in this manual.

ADD GASOLINE

- Fill fuel tank. Use fresh, clean, regular unleaded gasoline with a minimum of 87 octane. (Use of leaded gasoline will increase carbon and lead oxide deposits and reduce valve life). Do not mix oil with gasoline. Purchase fuel in quantities that can be used within 30 days to assure fuel freshness.

IMPORTANT: When operating in temperatures below 32°F(0°C), use fresh, clean winter grade gasoline to help insure good cold weather starting.

WARNING: Experience indicates that alcohol blended fuels (called gasohol or using ethanol or methanol) can attract moisture which leads to separation and formation of acids during storage. Acidic gas can damage the fuel system of an engine while in storage. To avoid engine problems, the fuel system should be emptied before storage of 30 days or longer. Drain the gas tank, start the engine and let it run until the fuel lines and carburetor are empty. Use fresh fuel next season. See Storage Instructions for additional information. Never use engine or carburetor cleaner products in the fuel tank or permanent damage may occur.

CAUTION: Fill to bottom of gas tank filler neck. Do not overfill. Wipe off any spilled oil or fuel. Do not store, spill or use gasoline near an open flame.

TO START ENGINE

When starting the engine for the first time or if the engine has run out of fuel, it will take extra cranking time to move fuel from the tank to the engine.

- Be sure freewheel control is in the transmission engaged position.
- Sit on seat in operating position, depress clutch/brake pedal and set parking brake.
- Place motion control lever in neutral (N) position.
- Move attachment clutch to "DISENGAGED" position.
- Move throttle control to fast position
- Pull choke control out for a cold engine start attempt. For a warm engine start attempt the choke control may not be needed.

NOTE: Before starting, read the warm and cold starting procedures below.

- Insert key into ignition and turn key clockwise to "START" position and release key as soon as engine starts. Do not run starter continuously for more than fifteen seconds per minute. If the engine does not start after several attempts, push choke control in, wait a few minutes and try again. If engine still does not start, pull the choke control out and retry.

WARM WEATHER STARTING (50° F and above)

- When engine starts, slowly push choke control in until the engine begins to run smoothly. If the engine starts to run roughly, pull the choke control out slightly for a few seconds and then continue to push the control in slowly.
- The attachments and ground drive can now be used. If the engine does not accept the load, restart the engine and allow it to warm up for one minute using the choke as described above.

COLD WEATHER STARTING (50° F and below)

- When engine starts, slowly push choke control in until the engine begins to run smoothly. Continue to push the choke control in small steps allowing the engine to accept small changes in speed and load, until the choke control is fully in. If the engine starts to run roughly, pull the choke control out slightly for a few seconds and then continue to push the control in slowly. This may require an engine warm-up period from several seconds to several minutes, depending on the temperature.

AUTOMATIC TRANSMISSION WARM UP

- Before driving the unit in cold weather, the transmission should be warmed up as follows:
 - Be sure the tractor is on level ground.
 - Place the motion control lever in neutral. Release the parking brake and let the clutch/brake slowly return to operating position.
 - Allow one minute for transmission to warm up. This can be done during the engine warm up period.

- The attachments can be used during the engine warm-up period after the transmission has been warmed up and may require the choke control be pulled out slightly.

NOTE: If at a high altitude (above 3000 feet) or in cold temperatures (below 32 F) the carburetor fuel mixture may need to be adjusted for best engine performance. See "TO ADJUST CARBURETOR" in the Service and Adjustments section of this manual.

PURGE TRANSMISSION

CAUTION: Never engage or disengage freewheel lever while the engine is running.

To ensure proper operation and performance, it is recommended that the transmission be purged before operating tractor for the first time. This procedure will remove any trapped air inside the transmission which may have developed during shipping of your tractor.

IMPORTANT: Should your transmission require removal for service or replacement, it should be purged after reinstallation before operating the tractor.

- Place tractor safely on level surface with engine off and parking brake set.
 - Disengage transmission by placing freewheel control in freewheeling position (See "TO TRANSPORT" in this section of manual).
 - Sitting in the tractor seat, start engine. After the engine is running, move throttle control to slow position. With motion control lever in neutral (N) position, slowly disengage clutch/brake pedal.
 - Move motion control lever to full forward position and hold for five (5) seconds. Move lever to full reverse position and hold for five (5) seconds. Repeat this procedure three (3) times.
- NOTE:** During this procedure there will be no movement of drive wheels. The air is being removed from hydraulic drive system.
- Move motion control lever to neutral (N) position. Shut-off engine and set parking brake.
 - Engage transmission by placing freewheel control in driving position (See "TO TRANSPORT" in this section of manual).

- Sitting in the tractor seat, start engine. After the engine is running, move throttle control to half (1/2) speed. With motion control lever in neutral (N) position, slowly disengage clutch/brake pedal.
- Slowly move motion control lever forward, after the tractor moves approximately five (5) feet, slowly move motion control lever to reverse position. After the tractor moves approximately five (5) feet return the motion control lever to the neutral (N) position. Repeat this procedure with the motion control lever three (3) times.
- Your tractor is now purged and now ready for normal operation.

MOWING TIPS

- Tire chains cannot be used when the mower housing is attached to tractor.
- Mower should be properly leveled for best mowing performance. See "TO LEVEL MOWER HOUSING" in the Service and Adjustments section of this manual.
- The left hand side of mower should be used for trimming.
- Drive so that clippings are discharged onto the area that has been cut. Have the cut area to the right of the tractor. This will result in a more even distribution of clippings and more uniform cutting.

- When mowing large areas, start by turning to the right so that clippings will discharge away from shrubs, fences, driveways, etc. After one or two rounds, mow in the opposite direction making left hand turns until finished.
- If grass is extremely tall, it should be mowed twice to reduce load and possible fire hazard from dried clippings. Make first cut relatively high; the second to the desired height.
- Do not mow grass when it is wet. Wet grass will plug mower and leave undesirable clumps. Allow grass to dry before mowing.
- **Always operate engine at full throttle when mowing** to assure better mowing performance and proper discharge of material. Regulate ground speed by selecting a low enough gear to give the mower cutting performance as well as the quality of cut desired.
- When operating attachments, select a ground speed that will suit the terrain and give best performance of the attachment being used.

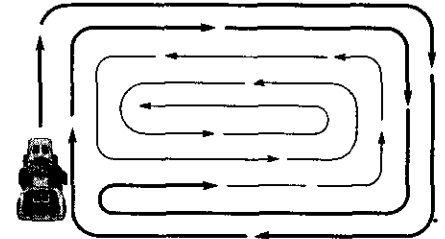

MAINTENANCE

MAINTENANCE SCHEDULE		SERVICE DATES						
FILL IN DATES AS YOU COMPLETE REGULAR SERVICE		BEFORE EACH USE	EVERY 8 HOURS	EVERY 25 HOURS	EVERY 50 HOURS	EVERY 100 HOURS	EVERY SEASON	BEFORE STORAGE
T R A C T O R	Check Brake Operation	✓	✓					
	Check Tire Pressure	✓	✓					
	Check Operator Presence and Interlock Systems	✓						
	Check for Loose Fasteners	✓				✓ ₇	✓	
	Sharpen/Replace Mower Blades			✓ ₄				
	Lubrication Chart			✓			✓	
	Check Battery Level			✓ ₆				
	Clean Battery and Terminals			✓			✓	
	Check Transaxle Cooling			✓				
	Adjust Blade Belt(s) Tension					✓ ₅		
	Adjust Motion Drive Belt(s) Tension					✓ ₅		
	E N G I N E	Check Engine Oil Level	✓	✓				
Change Engine Oil				✓ _{1,2,3}			✓	
Clean Air Filter				✓ ₂				
Clean Air Screen				✓ ₂				
Inspect Muffler/Spark Arrester					✓			
Replace Oil Filter (If equipped)						✓ _{1,2}		
Clean Engine Cooling Fins						✓ ₂		
Replace Spark Plug						✓	✓	
Replace Air Filter Paper Cartridge						✓ ₂		
Replace Fuel Filter							✓	

- 1 - Change more often when operating under a heavy load or in high ambient temperatures.
 2 - Service more often when operating in dirty or dusty conditions.
 3 - If equipped with oil filter, change oil every 50 hours.
 4 - Replace blades more often when mowing in sandy soil.
 5 - If equipped with adjustable system.
 6 - Not required if equipped with maintenance-free battery.
 7 - Tighten front axle pivot bolt to 35 ft.-lbs. maximum. Do not overtighten.

GENERAL RECOMMENDATIONS

The warranty on this tractor does not cover items that have been subjected to operator abuse or negligence. To receive full value from the warranty, operator must maintain tractor as instructed in this manual.

Some adjustments will need to be made periodically to properly maintain your tractor.

All adjustments in the Service and Adjustments section of this manual should be checked at least once each season.

- Once a year you should replace the spark plug, clean or replace air filter, and check blades and belts for wear. A new spark plug and clean air filter assure proper air-fuel mixture and help your engine run better and last longer.

BEFORE EACH USE

- Check engine oil level.
- Check brake operation.
- Check tire pressure.
- Check operator presence and interlock systems for proper operation.
- Check for loose fasteners.

LUBRICATION CHART

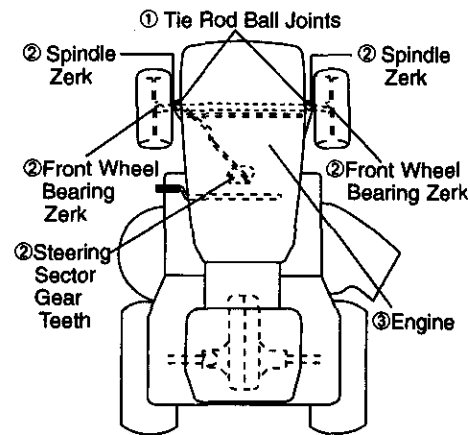

- ① Spray Silicone Lubriant (Move Boots to Lubricate)
 - ② General Purpose Grease
 - ③ Refer to Maintenance "ENGINE" Section
- IMPORTANT:** Do not oil or grease the pivot points which have special nylon bearings. Viscous lubricants will attract dust and dirt that will shorten the life of the self-lubricating bearings. If you feel they must be lubricated, use only a dry, powdered graphite type lubricant sparingly.

TRACTOR

Always observe safety rules when performing any maintenance.

BRAKE OPERATION

If tractor requires more than six (6) feet stopping distance at high speed in highest gear, then brake must be adjusted. (See "TO ADJUST BRAKE" in the Service and Adjustments section of this manual).

TIRES

- Maintain proper air pressure in all tires (See "PRODUCT SPECIFICATIONS" section of this manual).
- Keep tires free of gasoline, oil, or insect control chemicals which can harm rubber.
- Avoid stumps, stones, deep ruts, sharp objects and other hazards that may cause tire damage.

NOTE: To seal tire punctures and prevent flat tires due to slow leaks, tire sealant may be purchased from your local parts dealer. Tire sealant also prevents tire dry rot and corrosion.

OPERATOR PRESENCE SYSTEM

Be sure operator presence and interlock systems are working properly. If your tractor does not function as described, repair the problem immediately.

- The engine should not start unless the clutch/brake pedal is fully depressed and attachment clutch control is in the disengaged position.
- When the engine is running, any attempt by the operator to leave the seat without first setting the parking brake should shut off the engine.
- When the engine is running and the attachment clutch is engaged, any attempt by the operator to leave the seat should shut off the engine.
- The attachment clutch should never operate unless the operator is in the seat.

BLADE CARE

For best results mower blades must be kept sharp. Replace bent or damaged blades.

BLADE REMOVAL

- Raise mower to highest position to allow access to blades.
- Remove hex bolt, lock washer and flat washer securing blade.
- Install new or resharpened blade with trailing edge up towards deck as shown

IMPORTANT: To ensure proper assembly, center hole in blade must align with star on mandrel assembly.

- Reassemble hex bolt, lock washer and flat washer in exact order as shown.
- Tighten bolt securely (27-35 Ft. Lbs. torque).

IMPORTANT: Blade bolt is Grade 8 heat treated.

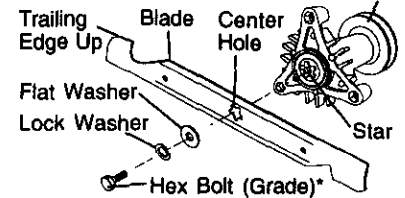

*A Grade 8 heat treated bolt can be identified by six lines on the bolt head.

TO SHARPEN BLADE

NOTE: We do not recommend sharpening blade - but if you do, be sure the blade is balanced.

Care should be taken to keep the blade balanced. An unbalanced blade will cause excessive vibration and eventual damage to mower and engine.

- The blade can be sharpened with a file or on a grinding wheel. Do not attempt to sharpen while on the mower.
- To check blade balance, you will need a 5/8" diameter steel bolt, pin, or a cone balancer. (When using a cone balancer, follow the instructions supplied with balancer.)

NOTE: Do not use a nail for balancing blade. The lobes of the center hole may appear to be centered, but are not.

- Slide blade on to an unthreaded portion of the steel bolt or pin and hold the bolt or pin parallel with the ground. If blade is balanced, it should remain in a horizontal position. If either end of the blade moves downward, sharpen the heavy end until the blade is balanced.

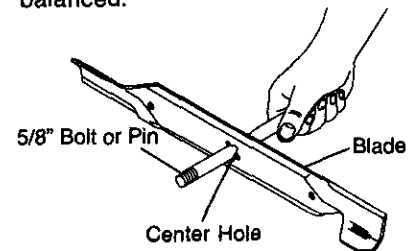

BATTERY

Your tractor has a battery charging system which is sufficient for normal use. However, periodic charging of the battery with an automotive charger will extend its life.

- Keep battery and terminals clean.
- Keep battery bolts tight.
- Keep small vent holes open.
- Recharge at 6-10 amperes for 1 hour.

NOTE: The original equipment battery on your tractor is maintenance free. Do not attempt to open or remove caps or covers. Adding or checking level of electrolyte is not necessary.

TO CLEAN BATTERY AND TERMINALS

Corrosion and dirt on the battery and terminals can cause the battery to "leak" power.

- Remove terminal guard.
- Disconnect BLACK battery cable first then RED battery cable and remove battery from tractor.
- Rinse the battery with plain water and dry.
- Clean terminals and battery cable ends with wire brush until bright.
- Coat terminals with grease or petroleum jelly.
- Reinstall battery (See "REPLACING BATTERY" in the SERVICE AND ADJUSTMENTS section of this manual).

V-BELTS

Check V-belts for deterioration and wear after 100 hours of operation and replace if necessary. The belts are not adjustable. Replace belts if they begin to slip from wear.

TRANSAXLE COOLING

The transmission fan and cooling fins should be kept clean to assure proper cooling.

Do not attempt to clean fan or transmission while engine is running or while the transmission is hot. To prevent possible damage to seals, do not use high pressure water or steam to clean transaxle.

- Inspect cooling fan to be sure fan blades are intact and clean.
- Inspect cooling fins for dirt, grass clippings and other materials. To prevent damage to seals, do not use compressed air or high pressure sprayer to clean cooling fins.

TRANSAXLE PUMP FLUID

The transaxle was sealed at the factory and fluid maintenance is not required for the life of the transaxle. Should the transaxle ever leak or require servicing, contact your nearest authorized service center/department.

ENGINE

LUBRICATION

Only use high quality detergent oil rated with API service classification SF, SG, or SH. Select the oil's SAE viscosity grade according to your expected operating temperature.

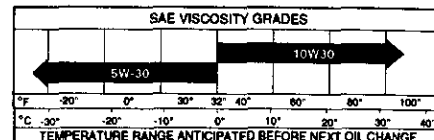

Change the oil after every 50 hours of operation or at least once a year if the tractor is not used for 50 hours in one year.

Check the crankcase oil level before starting the engine and after each eight (8) hours of operation. Tighten oil fill cap/dipstick securely each time you check the oil level.

TO CHANGE ENGINE OIL

Determine temperature range expected before oil change. All oil must meet API service classification SF, SG, or SH.

- Be sure tractor is on level surface.
- Oil will drain more freely when warm.
- Catch oil in a suitable container.
- Remove oil fill cap/dipstick. Be careful not to allow dirt to enter the engine when changing oil.
- Remove drain plug.
- After oil has drained completely, replace oil drain plug and tighten securely.
- Refill engine with oil through oil fill dipstick tube. Pour slowly. Do not overfill. For approximate capacity see "PRODUCT SPECIFICATIONS" section of this manual.
- Use gauge on oil fill cap/dipstick for checking level. Insert dipstick into the tube and rest the oil fill cap on the tube. Do not thread the cap onto the tube when taking reading. Keep oil at "FULL" line on dipstick. Tighten cap onto the tube securely when finished.

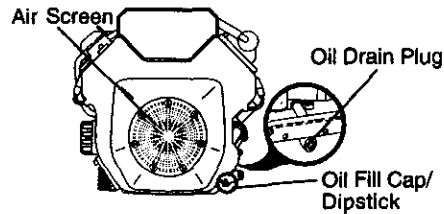

CLEAN AIR SCREEN

Air screen must be kept free of dirt and chaff to prevent engine damage from overheating. Clean with a wire brush or compressed air to remove dirt and stubborn dried gum fibers.

CLEAN AIR INTAKE/COOLING AREAS

To insure proper cooling, make sure the grass screen, cooling fins, and other external surfaces of the engine are kept clean at all times.

Every 100 hours of operation (more often under extremely dusty, dirty conditions), remove the blower housing and other cooling shrouds. Clean the cooling fins and external surfaces as necessary. Make sure the cooling shrouds are reinstalled.

NOTE: Operating the engine with a blocked grass screen, dirty or plugged cooling fins, and/or cooling shrouds removed will cause engine damage due to overheating.

AIR FILTER

Your engine will not run properly using a dirty air filter. Clean the foam pre-cleaner after every 25 hours of operation or every season. Service paper cartridge every 100 hours of operation or every season, whichever occurs first.

Service air cleaner more often under dusty conditions.

- Loosen knob and remove cover.

TO SERVICE PRE-CLEANER

- Slide foam pre-cleaner off cartridge.
- Wash it in liquid detergent and water.
- Squeeze it dry in a clean cloth. Allow it to dry.
- Saturate it in engine oil. Wrap it in clean, absorbent cloth and squeeze to remove excess oil.

TO SERVICE CARTRIDGE

- Replace a dirty, bent, or damaged cartridge.

NOTE: Do not wash the paper cartridge or use pressurized air, as this will damage the cartridge.

- Remove nut and cartridge plate.
- Reinstall the pre-cleaner (cleaned and oiled) over the paper cartridge.
- Check rubber seal for damage and proper position around stud. Replace if necessary.

- Reassemble air cleaner, cartridge plate, and nut.
- Reinstall air cleaner cover and secure by tightening knob.

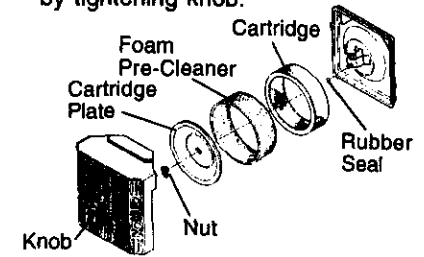

ENGINE OIL FILTER

Replace the engine oil filter every season or every other oil change if the tractor is used more than 100 hours in one year.

MUFFLER

Inspect and replace corroded muffler and spark arrester (if equipped) as it could create a fire hazard and/or damage.

SPARK PLUGS

Replace spark plugs at the beginning of each mowing season or after every 100 hours of operation, whichever occurs first. Spark plug type and gap setting are shown in "PRODUCT SPECIFICATIONS" section of this manual.

IN-LINE FUEL FILTER

The fuel filter should be replaced once each season. If fuel filter becomes clogged, obstructing fuel flow to carburetor, replacement is required.

- With engine cool, remove filter and plug fuel line sections.
- Place new fuel filter in position in fuel line with arrow pointing towards carburetor.
- Be sure there are no fuel line leaks and clamps are properly positioned.
- Immediately wipe up any spilled gasoline.

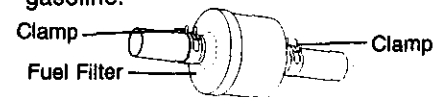

CLEANING

- Clean engine, battery, seat, finish, etc. of all foreign matter.
- Keep finished surfaces and wheels free of all gasoline, oil, etc.
- Protect painted surfaces with automotive type wax.

We do not recommend using a garden hose to clean your tractor unless the electrical system, muffler, air filter and carburetor are covered to keep water out. Water in engine can result in a shortened engine life.

SERVICE AND ADJUSTMENTS

⚠ CAUTION: Before performing any service or adjustments:

- Depress clutch/brake pedal fully and set parking brake.
- Place motion control lever in neutral (N) position.
- Place attachment clutch in "DISENGAGED" position.
- Turn ignition key "OFF" and remove key.
- Make sure the blades and all moving parts have completely stopped.
- Disconnect spark plug wire from spark plug and place wire where it cannot come in contact with plug.

TRACTOR

TO REMOVE MOWER

- Place attachment clutch in "DISENGAGED" position.
- Turn height adjustment knob to lowest setting.
- Lower mower to its lowest position.
- Remove retainer spring holding anti-swaybar to chassis bracket and disengage anti-swaybar from bracket.
- Remove retainer springs from suspension arms at deck and disengage arms from deck.
- Raise attachment lift to its highest position.
- Remove two retainer springs from each front link and remove links.
- Slide mower forward and remove belt from electric clutch pulley.
- Slide mower out from under right side of tractor.

IMPORTANT: If an attachment other than the mower deck is to be mounted on the tractor, remove the front links.

TO INSTALL MOWER

Follow procedure described in "INSTALL MOWER AND DRIVE BELT" in the Assembly section of this manual.

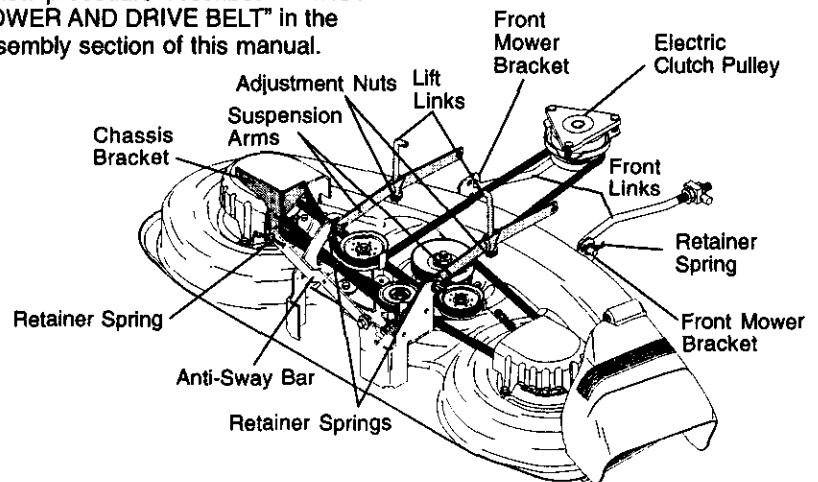

TO LEVEL MOWER HOUSING

Adjust the mower while tractor is parked on level ground or driveway. Make sure tires are properly inflated (See "PRODUCT SPECIFICATIONS" on page 3 of this manual). If tires are over or underinflated, you will not properly adjust your mower.

SIDE-TO-SIDE ADJUSTMENT

- Raise mower to its highest position.
- Measure height from bottom of deck curl to ground level at front corners of mower. Distance "A" on both sides of mower should be the same.
- If adjustment is necessary, make adjustment on one side of mower only.
- To raise one side of mower, tighten lift link adjustment nut on that side.
- To lower one side of mower, loosen lift link adjustment nut on that side.

NOTE: Each full turn of adjustment nut will change mower height about 3/16".

- Recheck measurements after adjusting.

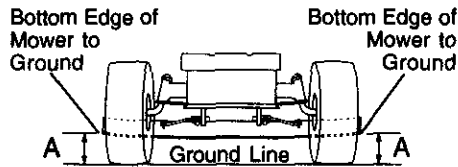

FRONT-TO-BACK ADJUSTMENT

IMPORTANT: DECK MUST BE LEVEL SIDE-TO-SIDE. If the following front-to-back adjustment is necessary, be sure to adjust both front links equally so mower will stay level side-to-side.

To obtain the best cutting results, the mower housing should be adjusted so the front is approximately 1/8" to 1/2" lower than the rear when the mower is in its highest position.

Check adjustment on right side of tractor. Measure distance "F" directly in front of and behind the mandrel at bottom edge of mower housing as shown.

- Before making any necessary adjustments, check that both front links are equal in length.
- If links are not equal in length, adjust one link to same length as other link.
- To lower front of mower housing, loosen nut "G" on both front links an equal number of turns.
- When distance "F" is 1/8" to 1/2" lower at front than rear, tighten nut "H" against trunnion on both front links.
- To raise front of mower housing, loosen nut "H" from trunnion on both front links. Tighten nut "G" on both front links an equal number of turns.
- When distance "F" is 1/8" to 1/2" lower at front than rear, tighten nut "H" against trunnion on both front links.

NOTE: Each full turn of nut "G" will change dim. "F" by approximately 3/8".

- Recheck side-to-side adjustment.

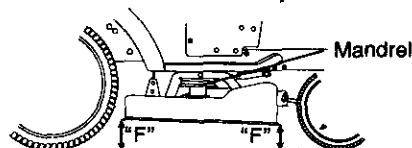

Both Front Links Should be Equal in Length

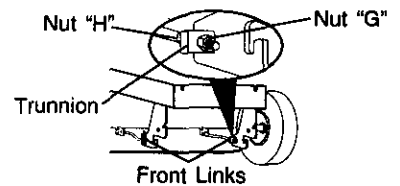
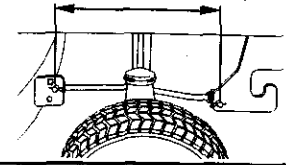

TO REPLACE MOWER DRIVE BELT

MOWER DRIVE BELT REMOVAL

- Park tractor on a level surface. Engage parking brake.
- Remove screws from L.H. mandrel cover and remove cover.
- Roll belt over the top of L.H. mandrel pulley.
- Remove belt from electric clutch pulley.
- Remove belt from idler pulleys.
- Remove any dirt or grass clippings which may have accumulated around mandrels and entire upper deck surface.
- Check primary idler arm and two idlers to see that they rotate freely.
- Be sure spring is securely hooked to primary idler arm and bolt in mower housing.

MOWER DRIVE BELT INSTALLATION

- Install belt in both idlers. Make sure belt is in both belt keepers at the idlers as shown.
- Install new belt onto electric clutch pulley.
- Roll belt into upper groove of L.H. mandrel pulley.
- Carefully check belt routing making sure belt is in the grooves correctly and inside belt keepers.
- Reassemble L.H. mandrel cover.

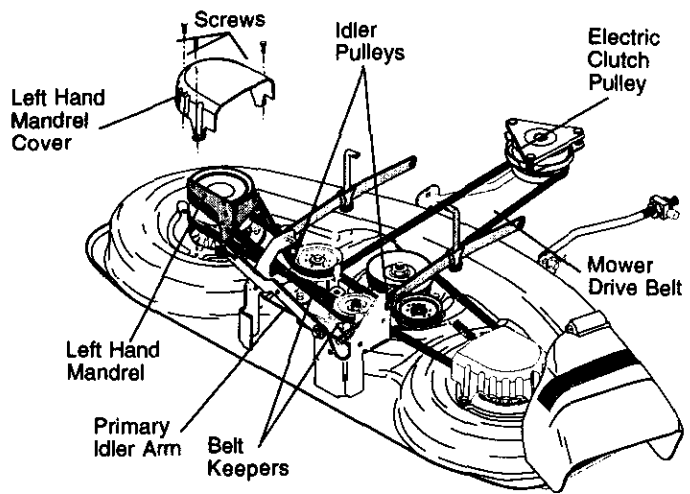

TO REPLACE MOWER BLADE DRIVE BELT

Park the tractor on level surface. Engage parking brake.

- Remove mower drive belt (See "TO REPLACE MOWER DRIVE BELT" in this section of this manual).
- Remove mower (See "TO REMOVE MOWER" in this section of this manual).
- Remove screws from R.H. mandrel cover and remove cover. Unhook spring from bolt on mower housing.
- Carefully roll belt off R.H. mandrel pulley.
- Remove belt from center mandrel pulley, idler pulley, and L.H. mandrel pulley.
- Remove any dirt or grass which may have accumulated around mandrels and entire upper deck surface.
- Check secondary idler arm and idler to see that they rotate freely.
- Be sure spring is hooked in secondary idler arm and sway-bar bracket.
- Install new belt in lower groove of L.H. mandrel pulley, idler pulley, and center mandrel pulley as shown.
- Roll belt over R.H. mandrel pulley. Make sure belt is in all grooves properly.
- Reconnect spring to bolt in mower housing and reinstall R.H. mandrel cover.
- Reinstall mower to tractor (See "INSTALL MOWER AND DRIVE BELT" in the Assembly section of this manual).

- Reassemble mower drive belt (See "TO REPLACE MOWER DRIVE BELT" in this section of this manual).

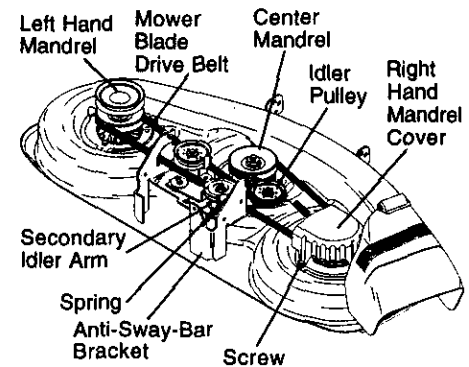

TO ADJUST ATTACHMENT CLUTCH

The electric clutch should provide years of service. The clutch has a built-in brake that stops the pulley within 5 seconds. Eventually, the internal brake will wear which may cause the mower blades to not engage, or, to not stop as required. Adjustments should be made by your nearest authorized service center/department.

- Make sure attachment clutch and ignition switches are in "OFF" position.
- Adjust the three nylon locknuts until space between clutch plate and rotor measures .012" at all three slot locations cut in the side of brake plate.

NOTE: After installing a new electric clutch, run tractor at full throttle and engage and disengage electric clutch 10 cycles to wear in clutch plate.

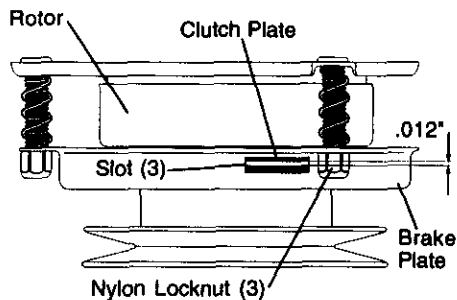

TO ADJUST BRAKE

Your tractor is equipped with an adjustable brake system which is mounted on the right side of the transaxle.

If tractor requires more than six (6) feet stopping distance at high speed in highest gear, then brake must be adjusted.

- Depress clutch/brake pedal and engage parking brake.
- Measure distance between brake operating arm and nut "A" on brake rod.
- If distance is other than 1-1/2", loosen jam nut and turn nut "A" until distance becomes 1-1/2". Retighten jam nut against nut "A".
- Road test tractor for proper stopping distance as stated above. Readjust if necessary. If stopping distance is still greater than six (6) feet in highest gear, further maintenance is necessary. Contact your nearest authorized service center/department.

With Parking Brake "Engaged"

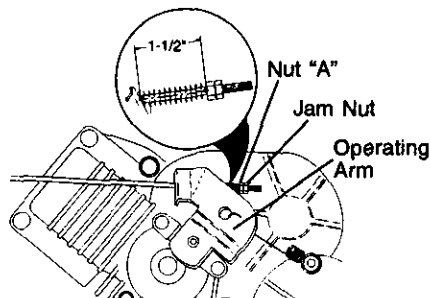

TO REPLACE MOTION DRIVE BELT

Park the tractor on level surface. Engage parking brake. For ease of service there is a belt installation guide decal on bottom of left footrest.

- Remove mower (See "TO REMOVE MOWER" in this section of this manual.)

BELT REMOVAL -

- Engage parking brake (creates slack in belt).
- Remove belt from clutching and fan idler pulleys.
- Loosen belt keeper above transaxle pulley.
- Remove belt from transaxle pulley.
- Remove belt from engine pulley and front V-idler pulley.
- Pull belt out of all belt keepers and remove from tractor.

BELT INSTALLATION -

- Place V part of belt into grooves on engine pulley and front V-idler, making sure to route belt inside of all belt keepers.
- Route belt on right side, coming from V-idler, towards back of tractor, above midspan belt keeper and to top of transaxle pulley.
- Route belt on left side, coming from engine pulley, towards back of tractor and through loop in midspan belt keeper.
- Place V part of belt into grooves on transaxle and fan idler pulleys, making sure to route belt inside of all belt keepers.
- Retighten belt keeper above transaxle pulley.
- Place belt around clutching idlers as shown, making sure to route belt inside of all belt keepers.
- Check to be sure belt is positioned correctly and is on proper side of all belt keepers.
- Reinstall mower.

IMPORTANT: Check brake adjustment.

Tractor V-Belt Drive Schematic Viewed From L.H. Side of Tractor

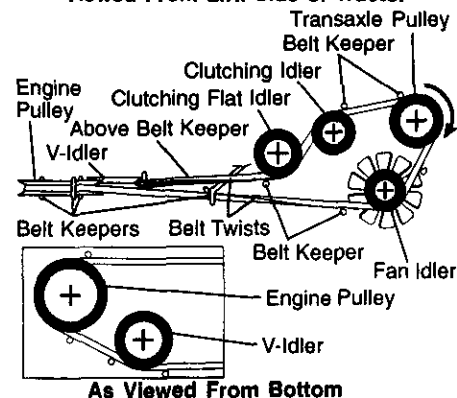

TO ADJUST MOTION CONTROL LEVER

The motion control lever has been preset at the factory and adjustment should not be necessary.

If for any reason the motion control lever will not hold its position while at a selected speed, it may be adjusted at the friction pack located on the right side of chassis.

- Park tractor on level surface. Stop tractor by turning ignition key to "OFF" position and engage parking brake.
- Place motion control lever in neutral (N) position.
- While holding locknut, loosen jam nut
- Tighten locknut 1/4 turn.
- While holding locknut, tighten jam nut securely.

NOTE: If for any reason the effort to move the motion control lever becomes too excessive, reverse the above adjustment procedure by loosening locknut 1/4 turn.

Road test tractor after adjustment and repeat procedure if necessary.

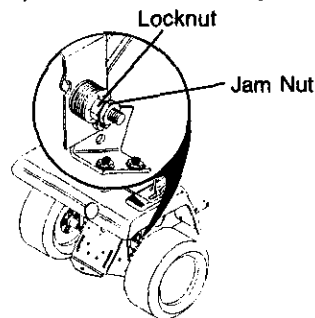

TRANSMISSION REMOVAL/REPLACEMENT

Should your transmission require removal for service or replacement, it should be purged after reinstallation and before operating the tractor. See "PURGE TRANSMISSION" in the Operation section of this manual.

TO ADJUST STEERING WHEEL ALIGNMENT

If steering wheel crossbars are not horizontal (left to right) when wheels are positioned straight forward, remove steering wheel and reassemble per instructions in the Assembly section of this manual.

FRONT WHEEL TOE-IN ADJUSTMENT

Front wheel toe-in is required for proper steering operation. Toe-in was set at the factory and adjustment should not be necessary. If parts in the front axle or steering mechanism have been replaced or damaged, check toe-in and adjust if necessary.

TO CHECK TOE-IN

- Position front wheels straight ahead.
- Measure distance between wheels at front and rear of tires (dimensions "A" and "B").
- Front dimension "A" should be 1/8" to 1/4" less than rear dimension "B".

TO ADJUST TOE-IN

- Loosen jam nuts at adjustment sleeves on tie rod.
- Adjust tie rod until dimension "A" is 1/8" to 1/4" less than dimension "B".
- Tighten jam nuts securely.

FRONT WHEEL CAMBER

The front wheel camber is not adjustable on your tractor. If damage has occurred to affect the front wheel camber, contact your nearest authorized service center/department.

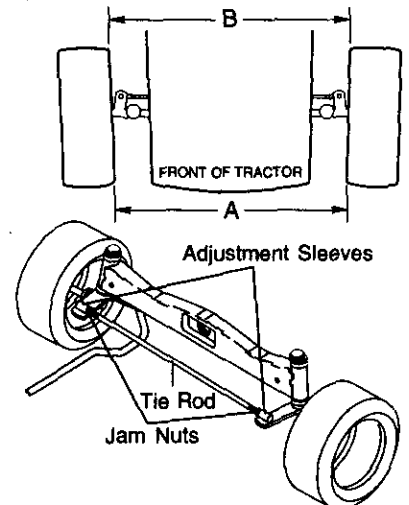

TO REMOVE WHEEL FOR REPAIRS FRONT WHEEL

- Block up axle securely.
- Remove axle cover, retaining ring and washers to allow wheel removal.
- Repair tire and reassemble.
- Replace washers and snap retaining ring securely in axle groove.
- Replace axle cover.

REAR WHEEL

- Block rear axle securely.
- Remove five (5) hub bolts to allow wheel removal.
- Repair tire and reassemble. Replace and tighten hub bolts securely.

NOTE: To seal tire punctures and prevent flat tires due to slow leaks, tire sealant may be purchased from your local parts dealer. Tire sealant also prevents tire dry rot and corrosion.

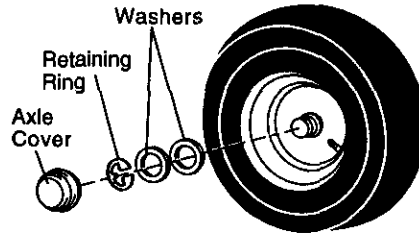

TO START ENGINE WITH A WEAK BATTERY

CAUTION: Lead-acid batteries generate explosive gases. Keep sparks, flame and smoking materials away from batteries. Always wear eye protection when around batteries.

If your battery is too weak to start the engine, it should be recharged. (See "BATTERY" in the MAINTENANCE section of this manual).

If "jumper cables" are used for emergency starting, follow this procedure:

IMPORTANT: Your tractor is equipped with a 12 volt negative grounded system. The other vehicle must also be a 12 volt negative grounded system. Do not use your tractor battery to start other vehicles.

TO ATTACH JUMPER CABLES -

- Connect each end of the RED cable to the POSITIVE (+) terminal of each battery, taking care not to short against chassis.
- Connect one end of the BLACK cable to the NEGATIVE (-) terminal of fully charged battery.
- Connect the other end of the BLACK cable to good CHASSIS GROUND, away from fuel tank and battery.

TO REMOVE CABLES, REVERSE ORDER -

- BLACK cable first from chassis and then from the fully charged battery.
- RED cable last from both batteries.

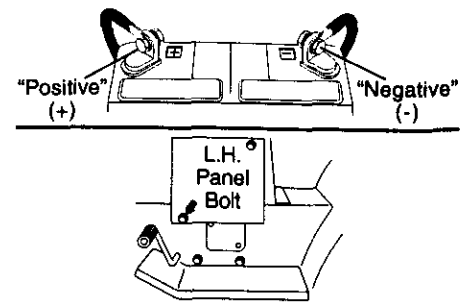

REPLACING BATTERY

CAUTION: Do not short battery terminals by allowing a wrench or any other object to contact both terminals at the same time. Before connecting battery, remove metal bracelets, wristwatch bands, rings, etc.

Positive terminal must be connected first to prevent sparking from accidental grounding.

- Lift hood to raised position.
- Remove terminal guard.
- Disconnect BLACK battery cable then RED battery cable and carefully remove battery from tractor.
- Install new battery with terminals in same position as old battery.
- Reinstall terminal guard.
- First connect RED battery cable to positive (+) battery terminal with hex bolt and keps nut as shown. Tighten securely.
- Connect BLACK grounding cable to negative (-) battery terminal with remaining hex bolt and keps nut. Tighten securely
- Close terminal access doors.
- Close hood.

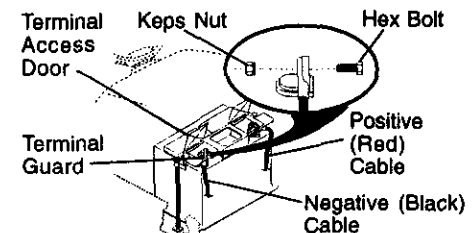

TO REPLACE HEADLIGHT BULB

- Raise hood.
- Pull bulb holder out of the hole in the backside of the grill.
- Replace bulb in holder and push bulb holder securely back into the hole in the backside of the grill.
- Close hood.

INTERLOCKS AND RELAYS

Loose or damaged wiring may cause your tractor to run poorly, stop running, or prevent it from starting.

- Check wiring. See electrical wiring diagram in the Repair Parts section.

TO REPLACE FUSE

Replace with 30 amp automotive-type plug-in fuse. The fuse holder is located behind the dash.

TO ADJUST ATTACHMENT LIFT SPRING

- While holding spring bushing with wrench, loosen jam nut.
- Turn adjustment bolt clockwise to extend spring and reduce lift effort for heavier attachments.
- Turn adjustment bolt counterclockwise for lighter attachments.
- Retighten jam nut against spring bushing.

IMPORTANT: Do not adjust for maximum spring tension when using light attachments such as a mower. Adjust lift lever spring to aid in lifting attachment. Do not overpower spring. When removing attachment, always adjust spring tension to its lowest position.

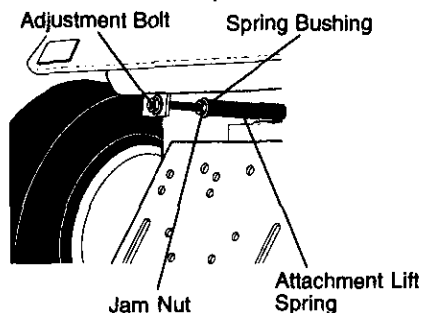

TO REMOVE HOOD AND GRILL ASSEMBLY

- Raise hood.
- Unsnap headlight wire connector.
- Stand in front of tractor. Grasp hood at sides, tilt toward engine and lift off of tractor.
- To replace, reverse above procedure.

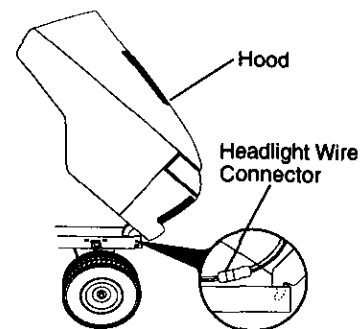

ENGINE

Maintenance, repair, or replacement of the emission control devices and systems, which are being done at the customers expense, may be performed by any non-road engine repair establishment or individual. Warranty repairs must be performed by an authorized engine manufacturer's service outlet.

TO ADJUST THROTTLE CONTROL CABLE

The throttle control has been preset at the factory and adjustment should not be necessary. Check adjustment as described below before loosening cable. If adjustment is necessary, proceed as follows:

- With engine not running, move throttle control lever to fast position.
- Check that speed control lever is against stop screw. If it is not, loosen casing clamp screw and pull throttle cable until lever is against screw. Tighten clamp screw securely.

Idle Fuel Adjusting Needle Idle speed Adjusting Screw

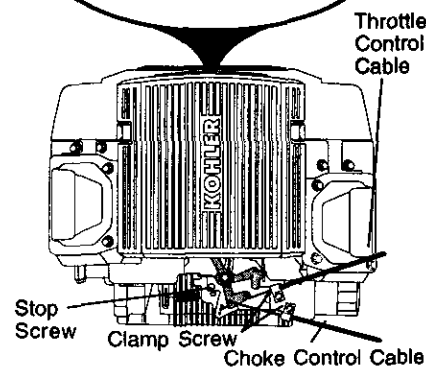
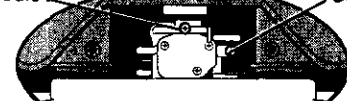

TO ADJUST CHOKE CONTROL

The choke control has been preset at the factory and adjustment should not be necessary. Check adjustment as described below before loosening cable. If adjustment is necessary, proceed as follows:

- With engine not running, move choke control (located on dash panel) to full choke position.
- Remove air cleaner cover, filter and cartridge plate to expose carburetor choke (See "AIR FILTER" in the Maintenance section of this manual).
- Choke should be closed. If it is not, loosen casing clamp screw and move choke cable until choke is completely closed. Tighten casing clamp screw securely.
- Reassemble air cleaner.

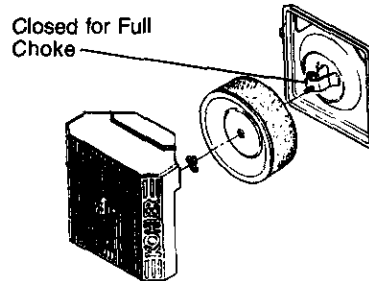

TO ADJUST CARBURETOR

The carburetor has been present at the factory and adjustment should not be necessary. However, minor adjustment may be required to compensate for differences in fuel, temperature, altitude or load. If the carburetor does need adjustment, proceed as follows:

In general, turning the adjusting needles **in** (clockwise) decreases the supply of fuel to the engine giving a leaner fuel/air mixture. Turning the adjusting needles **out** (counterclockwise) increases the supply of fuel to the engine giving a richer fuel/air mixture.

IMPORTANT: Damage to the needles and the seats in carburetor may result if screw is turned in too tight.

PRELIMINARY SETTING -

- Be sure you have a clean air filter, and the throttle control cable is adjusted properly (see "TO ADJUST THROTTLE CONTROL CABLE" in the Service and Adjustments section of this manual).
- With engine off turn idle fuel adjusting needle **in** (clockwise) closing it finger tight and then turn **out** (counterclockwise) 1 turn.

FINAL SETTING -

- Start engine and allow to warm for five minutes. Make final adjustments with engine running and shift/motion control lever in neutral (N) position.
- The high idle is set at the factory and cannot be adjusted.
- **Idle speed setting** - With throttle control lever in slow position, engine should idle at 1200 RPM. If engine idles too slow or fast, turn idle speed adjusting screw in or out until correct idle is attained.
- **Idle fuel needle setting** - With throttle control lever in slow position, turn idle fuel adjusting needle **in** (clockwise) until engine speed decreases and then turn **out** (counterclockwise) approximately 3/4 turn to obtain the best low speed performance.
- Recheck idle speed. Readjust if necessary.

ACCELERATION TEST -

- Move throttle control lever from slow to fast position. If engine hesitates or dies, turn idle fuel adjusting needle **out** (counterclockwise) 1/8 turn. Repeat test and continue to adjust, if necessary, until engine accelerates smoothly.

High speed stop is factory adjusted. Do not adjust-damage may result.

IMPORTANT: Never tamper with the engine governor, which is factory set for proper engine speed. Overspeeding the engine above the factory high speed setting can be dangerous. If you think the engine-governed high speed needs adjusting, contact your nearest authorized service center/department, which has proper equipment and experience to make any necessary adjustments.

STORAGE

Immediately prepare your tractor for storage at the end of the season or if the tractor will not be used for 30 days or more.

CAUTION: Never store the tractor with gasoline in the tank inside a building where fumes may reach an open flame or spark. Allow the engine to cool before storing in any enclosure.

TRACTOR

Remove mower from tractor for winter storage. When mower is to be stored for a period of time, clean it thoroughly, remove all dirt, grease, leaves, etc. Store in a clean, dry area.

- Clean entire tractor (See "CLEANING" in the Maintenance section of this manual).
- Inspect and replace belts, if necessary (See belt replacement instructions in the Service and Adjustments section of this manual).
- Lubricate as shown in the Maintenance section of this manual.
- Be sure that all nuts, bolts and screws are securely fastened. Inspect moving parts for damage, breakage and wear. Replace if necessary.
- Touch up all rusted or chipped paint surfaces; sand lightly before painting.

BATTERY

- Fully charge the battery for storage.
- After a period of time in storage, battery may require recharging.
- To help prevent corrosion and power leakage during long periods of storage, battery cables should be disconnected and battery cleaned thoroughly (see "TO CLEAN BATTERY AND TERMINALS" in the Maintenance section of this manual).
- After cleaning, leave cables disconnected and place cables where they cannot come in contact with battery terminals.
- If battery is removed from tractor for storage, do not store battery directly on concrete or damp surfaces.

ENGINE

FUEL SYSTEM

IMPORTANT: It is important to prevent gum deposits from forming in essential fuel system parts such as carburetor, fuel filter, fuel hose, or tank during storage. Also, experience indicates that alcohol blended fuels (called gasohol or using

ethanol or methanol) can attract moisture which leads to separation and formation of acids during storage. Acidic gas can damage the fuel system of an engine while in storage.

- Drain the fuel tank.
- Start the engine and let it run until the fuel lines and carburetor are empty.
- Never use engine or carburetor cleaner products in the fuel tank or permanent damage may occur.
- Use fresh fuel next season.

NOTE: Fuel stabilizer is an acceptable alternative in minimizing the formation of fuel gum deposits during storage. Add stabilizer to gasoline in fuel tank or storage container. Always follow the mix ratio found on stabilizer container. Run engine at least 10 minutes after adding stabilizer to allow the stabilizer to reach the carburetor. Do not drain the gas tank and carburetor if using fuel stabilizer.

ENGINE OIL

Drain oil (with engine warm) and replace with clean engine oil. (See "ENGINE" in the Maintenance section of this manual).

CYLINDER(S)

- Remove spark plug(s).
- Pour one ounce of oil through spark plug hole(s) into cylinder(s).
- Turn ignition key to "START" position for a few seconds to distribute oil.
- Replace with new spark plug(s).

OTHER

- Do not store gasoline from one season to another.
- Replace your gasoline can if your can starts to rust. Rust and/or dirt in your gasoline will cause problems.
- If possible, store your tractor indoors and cover it to give protection from dust and dirt.
- Cover your tractor with a suitable protective cover that does not retain moisture. Do not use plastic. Plastic cannot breathe which allows condensation to form and will cause your tractor to rust.

IMPORTANT: Never cover tractor while engine and exhaust areas are still warm.

TROUBLESHOOTING CHART

PROBLEM	CAUSE	CORRECTION
Will not start	<ul style="list-style-type: none"> • Out of fuel. • Engine not "CHOKED" properly. • Engine flooded. • Bad spark plug. • Dirty air filter. • Dirty fuel filter. • Water in fuel. • Loose or damaged wiring. • Carburetor out of adjustment. • Engine valves out of adjustment. 	<ul style="list-style-type: none"> • Fill fuel tank. • See "TO START ENGINE" in Operation section. • Wait several minutes before attempting to start. • Replace spark plug. • Clean/replace air filter. • Replace fuel filter. • Drain fuel tank and carburetor, refill tank with fresh gasoline and replace fuel filter. • Check all wiring. • See "To Adjust Carburetor" in Service Adjustments section. • Contact an authorized service center/department.
Hard to start	<ul style="list-style-type: none"> • Dirty air filter. • Bad spark plug. • Weak or dead battery. • Dirty fuel filter. • Stale or dirty fuel. • Loose or damaged wiring. • Carburetor out of adjustment. • Engine valves out of adjustment. 	<ul style="list-style-type: none"> • Clean/replace air filter. • Replace spark plug. • Recharge or replace battery. • Replace fuel filter. • Drain fuel tank and refill with fresh gasoline. • Check all wiring. • See "To Adjust Carburetor" in Service Adjustments section. • Contact an authorized service center/department.
Engine will not turn over	<ul style="list-style-type: none"> • Clutch/brake pedal not depressed. • Attachment clutch is engaged. • Weak or dead battery. • Blown fuse. • Corroded battery terminals. • Loose or damaged wiring. • Faulty ignition switch. • Faulty solenoid or starter. • Faulty operator presence switch(es). 	<ul style="list-style-type: none"> • Depress clutch/brake pedal. • Disengage attachment clutch. • Recharge or replace battery. • Replace fuse. • Clean battery terminals. • Check all wiring. • Check/replace ignition switch. • Check/replace solenoid or starter. • Contact an authorized service center/department.
Engine clicks but will not start	<ul style="list-style-type: none"> • Weak or dead battery. • Corroded battery terminals. • Loose or damaged wiring. • Faulty solenoid or starter. 	<ul style="list-style-type: none"> • Recharge or replace battery. • Clean battery terminals. • Check all wiring. • Check/replace solenoid or starter.
Loss of power	<ul style="list-style-type: none"> • Cutting too much grass/too fast. • Throttle in "CHOKE" position. • Build-up of grass, leaves and trash under mower. • Dirty air filter. • Low oil level/dirty oil. 	<ul style="list-style-type: none"> • Set in "Higher Cut" position/ reduce speed. • Adjust throttle control. • Clean underside of mower housing. • Clean/replace air filter. • Check oil level/change oil.

TROUBLESHOOTING CHART

PROBLEM	CAUSE	CORRECTION
Loss of power Continued	<ul style="list-style-type: none"> • Faulty spark plug. • Dirty fuel filter. • Stale or dirty fuel. • Water in fuel. • Spark plug wire loose. • Dirty engine air screen/fins. • Dirty/clogged muffler. • Loose or damaged wiring. • Carburetor out of adjustment. • Engine valves out of adjustment. 	<ul style="list-style-type: none"> • Clean and regap or change spark plug. • Replace fuel filter. • Drain fuel tank and refill with fresh gasoline. • Drain fuel tank and carburetor, refill tank with fresh gasoline and replace fuel filter. • Connect and tighten spark plug wire. • Clean engine air screen/fins. • Clean/replace muffler. • Check all wiring. • See "To Adjust Carburetor" in Service Adjustments section. • Contact an authorized service center/department.
Excessive vibration	<ul style="list-style-type: none"> • Worn, bent or loose blade. • Bent blade mandrel. • Loose/damaged part(s). 	<ul style="list-style-type: none"> • Replace blade. Tighten blade bolt. • Replace blade mandrel. • Tighten loose part(s). Replace damaged parts.
Engine continues to run when operator leaves seat with attachment clutch engaged	<ul style="list-style-type: none"> • Faulty operator-safety presence control system. 	<ul style="list-style-type: none"> • Check wiring, switches and connections. If not corrected, contact an authorized service center/department.
Poor cut - uneven	<ul style="list-style-type: none"> • Worn, bent or loose blade. • Mower deck not level. • Buildup of grass, leaves, and trash under mower. • Bent blade mandrel. • Clogged mower deck vent holes from buildup of grass, leaves, and trash around mandrels. 	<ul style="list-style-type: none"> • Replace blade. Tighten blade bolt. • Level mower deck. • Clean underside of mower housing. • Replace blade mandrel. • Clean around mandrels to open vent holes.
Mower blades will not rotate	<ul style="list-style-type: none"> • Obstruction in clutch mechanism. • Worn/damaged mower drive belt. • Frozen idler pulley. • Frozen blade mandrel. 	<ul style="list-style-type: none"> • Remove obstruction. • Replace mower drive belt. • Replace idler pulley. • Replace blade mandrel.
Poor grass discharge	<ul style="list-style-type: none"> • Engine speed too slow. • Travel speed too fast. • Wet grass. • Mower deck not level. • Low/uneven tire air pressure. 	<ul style="list-style-type: none"> • Place throttle control in "FAST" position. • Shift to slower speed. • Allow grass to dry before mowing. • Level mower deck. • Check tires for proper air pressure.

TROUBLESHOOTING CHART

PROBLEM	CAUSE	CORRECTION
Poor grass discharge (Contr)	<ul style="list-style-type: none"> • Worn, bent or loose blade. • Buildup of grass, leaves, and trash under mower. • Mower drive belt worn. • Blades improperly installed. • Improper blades used. • Clogged mower deck vent holes from buildup of grass, leaves, and trash around mandrels. 	<ul style="list-style-type: none"> • Replace/sharpen blade. • Tighten blade bolt. • Clean underside of mower housing. • Replace mower drive belt. • Reinstall blades sharp edge down. • Replace with blades listed in this manual. • Clean around mandrels to open vent holes.
Headlight(s) not working (if so equipped)	<ul style="list-style-type: none"> • Switch is "OFF". • Bulb(s) burned out. • Faulty light switch. • Loose or damaged wiring. • Blown fuse. 	<ul style="list-style-type: none"> • Turn switch "ON". • Replace bulb(s). • Check/replace light switch. • Check wiring and connections. • Replace fuse.
Battery will not charge	<ul style="list-style-type: none"> • Bad battery cell(s). • Poor cable connections. • Faulty regulator (if so equipped). • Faulty alternator. 	<ul style="list-style-type: none"> • Replace battery. • Check/clean all connections. • Replace regulator. • Replace alternator.
Loss of Drive	<ul style="list-style-type: none"> • Freewheel control in "disengaged" position. • Motion drive belt worn, damaged or broken. • Air trapped in transmission during shipment or servicing. 	<ul style="list-style-type: none"> • Place freewheel control in "engaged" position. • Replace motion drive belt. • Purge transmission.
Engine "backfires" when turning engine "OFF"	<ul style="list-style-type: none"> • Engine throttle control at "SLOW" position for 30 seconds before stopping engine. 	<ul style="list-style-type: none"> • Move throttle control to not set "SLOW" position and allow to idle for 30 seconds before stopping engine.

SCHEMATIC

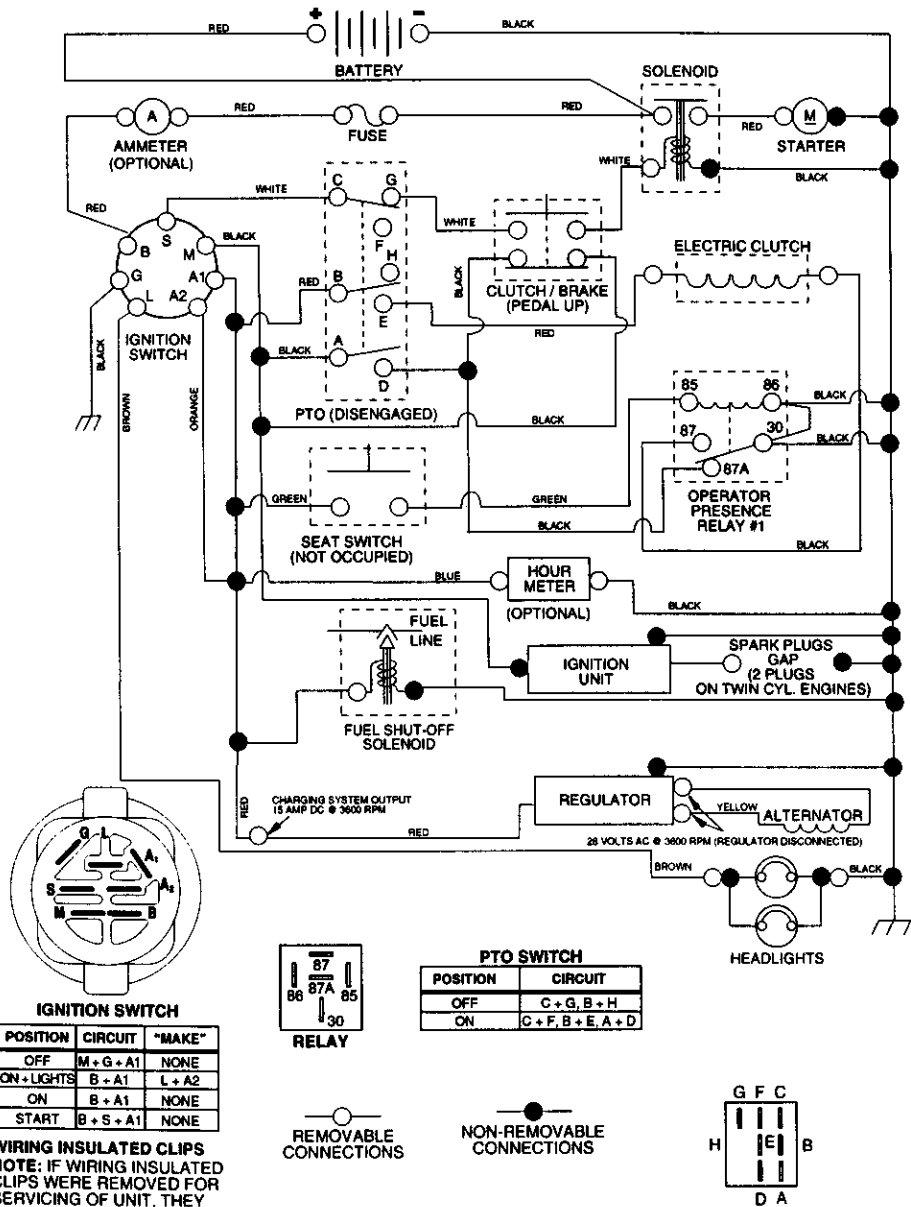

IGNITION SWITCH

POSITION	CIRCUIT	"MAKE"
OFF	M + G + A1	NONE
ON + LIGHTS	B + A1	L + A2
ON	B + A1	NONE
START	B + S + A1	NONE

WIRING INSULATED CLIPS
NOTE: IF WIRING INSULATED CLIPS WERE REMOVED FOR SERVICING OF UNIT, THEY SHOULD BE REPLACED TO PROPERLY SECURE YOUR WIRING.



PTO SWITCH

POSITION	CIRCUIT
OFF	C + G, B + H
ON	C + F, B + E, A + D

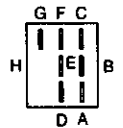

REPAIR PARTS

TRACTOR -- MODEL NUMBER 917.272960

ELECTRICAL

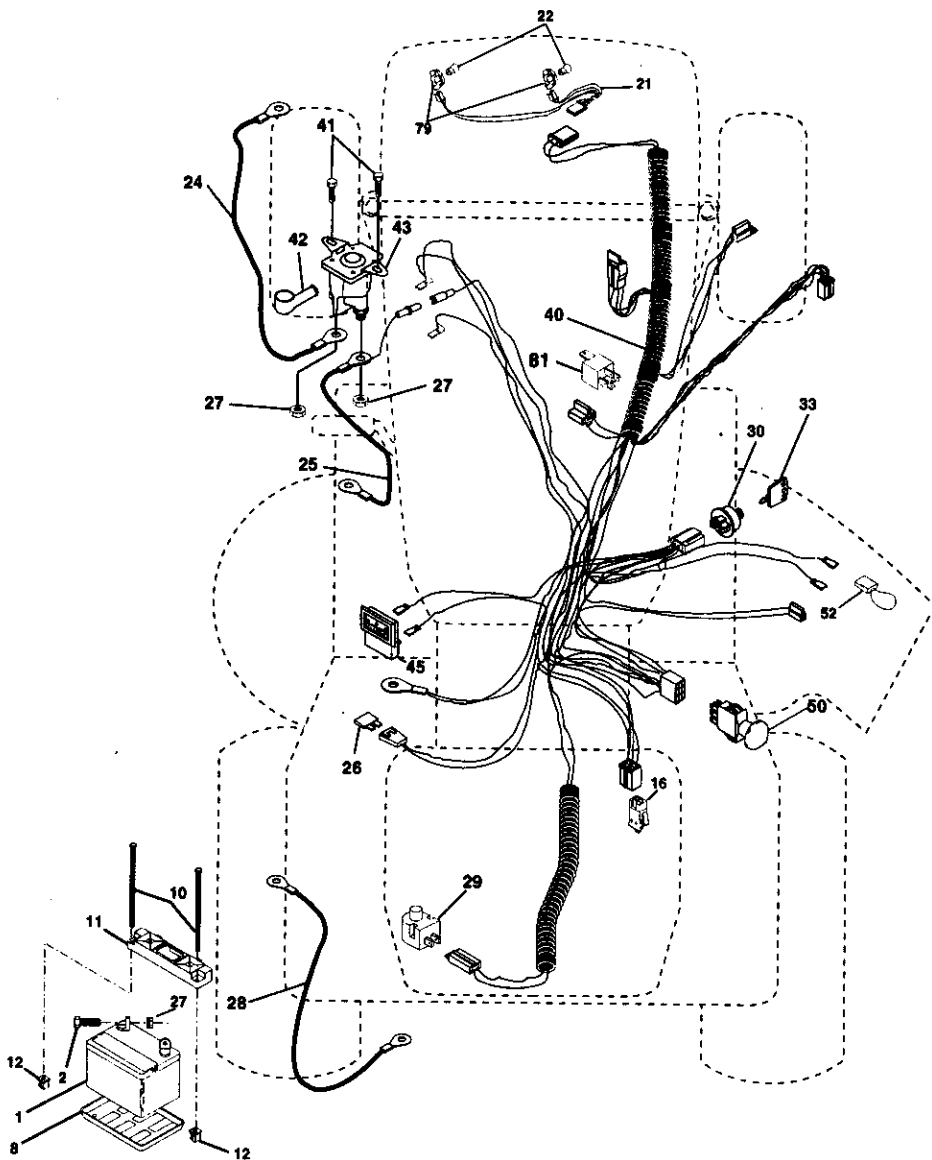

ELECTRICAL**TRACTOR -- MODEL NUMBER 917.272960**

KEY PART NO.	PART NO.	DESCRIPTION
1	144927	Battery
2	74760412	Bolt Hex Head 1/4-20 x 3/4
8	7603J	Tray, Battery
10	145211	Bolt 1/4-20 x 7.5 Zinc
11	150109	Hold down Battery Dash Mount
12	145769	Nut Push Nylon 1/4"
16	153664	Switch Interlock Push-In
21	166184	Harness Socket Light W4152J
22	4152J	Bulb Light
24	4014J	Cable, Battery
25	146686	Cable, Battery
26	108824X	Fuse
27	73510400	Nut Keps Hex 1/4-20 Unc
28	170697	Cable, Ground
29	160784	Switch, Plunger
30	163968	Switch, Ign
33	140403	Key, Ignition
40	170238	Harness Ign.
41	17720408	Screw 1/4-20 x 1/2
42	131563	Cover, Terminal
43	145673	Solenoid
45	122822X	Ammeter
50	169416	Switch, PTO
52	141940	Protection Wire Loop
79	163996	Bulbholder
81	109748X	Relay Asm.

NOTE: All component dimensions given in U. S.inches
1 inch = 25.4 mm

I RACTOR -- MODEL NUMBER 917.272960
CHASSIS AND ENCLOSURES

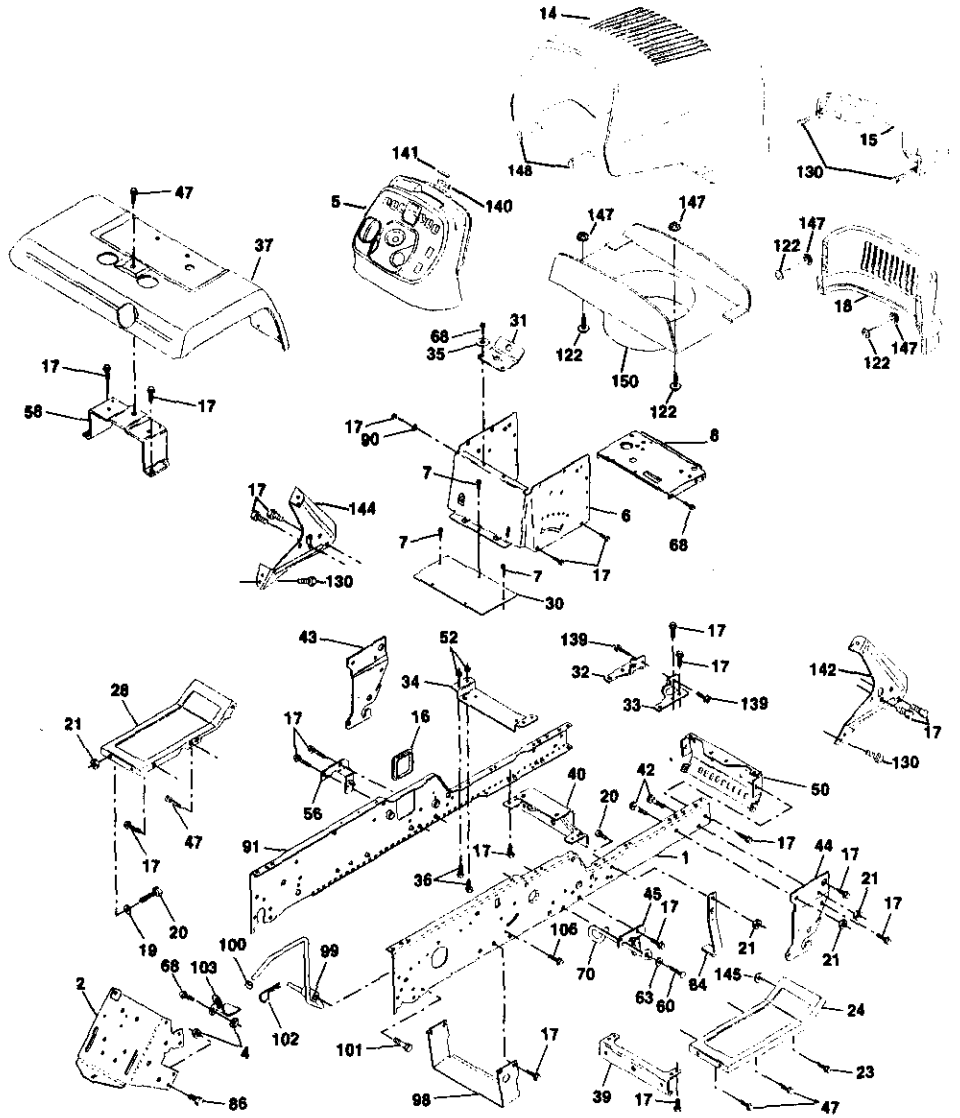

**TRACTOR -- MODEL NUMBER 917.272960
CHASSIS AND ENCLOSURES**

KEY PART NO. NO.	DESCRIPTION
1 150253	Rail, Frame RH
2 140506	Drawbar, Gt
4 73800700	Nut, Lock Hex 7/16 Unc
5 163976	Dash YTGT 2 Cyl
6 157882	Dash, Lower Vgt One Piece
7 17720408	Screw, Thd Cut 1/4-20 x 1/2
8 145166	Support, Battery
14 161023X558	Hood Asm., Pnt YTGT
15 160568	Lens Asm Headlight Bar
16 121794X	Cover, Access
17 17060612	Screw 3/8-16 x .75
18 160564X558	Grille
19 19131312	Washer 13/32 x 13/16 x 12 Ga.
20 STD523710	Bolt, Fin Hex 3/8-16 x 1
21 73680600	Nut Crownlock 3/8-16 Unc
23 17060616	Screw 3/8-16 x 1.5
24 145243X558	Footrest, RH
28 145244X558	Footrest, LH
30 145052	Saddle, Hydro
31 161419	Brace, Supt 1-pc VGT Steering
32 161327	Bracket, Pivot Chassis Lh
33 161326	Bracket, Pivot Chassis Rh
34 142131	Bracket, Engine Support Rear
35 19111116	Washer 11/32 x 11/16 x 16 Ga.
36 STD522507	Bolt, Fin Hex 5/16-18 x 3/4
37 167270X558	Fender Pnt
39 136961	Bracket, Axle Front
40 156111	Bracket, Support Axle/Engine
42 STD533710	Bolt, Carriage 3/8-16 x 1
43 136939	Bracket, Spnsn Front Lh
44 136940	Bracket, Spnsn Front Rh
45 154913	Bracket Asm., Susp Chassis Rh
47 17490608	Screw Thdrol. 3/8-16 x 1/2

KEY PART NO. NO.	DESCRIPTION
50 152728	Bracket, Chassis Front
52 STD541431	Nut, Crownlock 5/16-18 Unc
56 154914	Bracket Asm., Susp Chassis Lh
58 137113	Bracket Asm., Fender
60 17490620	Screw Thdrol. 3/8-16 x 1-1/4
63 19131614	Washer 13/32 x 1 x 14 Ga.
68 17490508	Screw Thdrol. 5/16-18 x 1/2
70 137159	Guide, Belt Mid Span
84 142992	Stop, Over Center Mower
86 74760716	Bolt Fin Hex 7/16-14 UNC x 1
90 STD551237	Washer, Lock Ext. Tooth 3/8
91 170755	Rail, Frame Lh
98 140503	Bracket Skid Chassis
99 140871	Rod By Pass
100 124236X	Cap By Pass Rod
101 17490628	Screw Thdrol 3/8-16 x 1-3/4
102 STD624003	Retainer, Spring
103 142273	Lock, By Pass
106 138776	Bolt 5/16-18 TT
122 161464	Screw Hex Wshd 8-18 x 7/8
130 164863	Screw Hwtd Hi-Lo #13-16 x 3/4
138 163975X428	Cup Holder
139 161330	Bolt Shoulder 5/16-18 TT
140 163806	Magnet YTGT
141 163805	Striker Plate YTGT
142 161897	Bracket Dash Rh
144 161900	Bracket Dash Lh
145 19131414	Washer Flat 13/32 x 7/8 x 14 Ga.
147 162967	Fastener Nut Pal
148 164655	Extrusion Bumpers
150 161237	Duct Heat Hood

NOTE: All component dimensions given in U. S. inches
1 inch = 25.4 mm

TRACTOR - MODEL NUMBER 917.272960
GROUND DRIVE

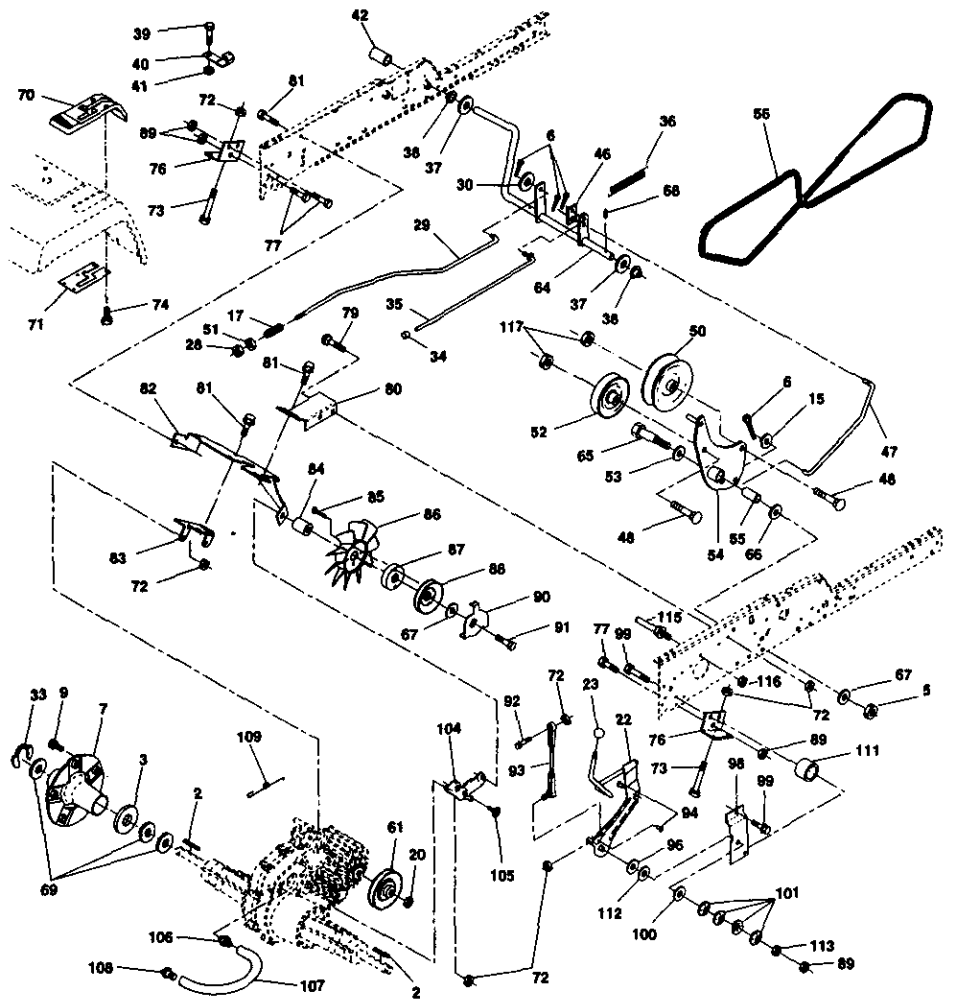

TRACTOR -- MODEL NUMBER 917.272960

GROUND DRIVE

KEY PART NO. NO.	DESCRIPTION	KEY PART NO. NO.	DESCRIPTION		
2	7070E	Key 1/4 x 2.5	71	151179	Plate Console Shift
3	7563R	Washer, Thrust, Axle	72	STD541431	Nut, Crownlock 5/16-18
5	STD541437	Nut, Crownlock 3/8-16	73	74490548	Bolt Hex Flghd 5/16-18 x 3 Gr5
6	STD561210	Pin, Cotter	74	142432	Screw Hex Wsh. Hi-Lo 1/4-1/2
7	140507	Wheel, Hub Assembly	76	140481	Bracket Transaxle
9	140080	Bolt, Hub	77	74760716	Bolt Fin Hex 7/16-14 x 1
15	STD551037	Wahser 13/32 x 13/16 x 16 Ga.	79	72110505	Bolt Carriage 5/16-18 x 5/8
17	140921	Spring	80	140484	Bracket Torque RH
20	73940800	Nut Hex Jam Toplock 1/2-20	81	17490612	Screw Thdrol 3/8-16 x 3/4
22	156103	Arm Asm Shift	82	150586	Bracket Mount Torque/Fan
23	130564	Knob	83	140479	Strap Torque Mid
28	STD541237	Nut	84	140490	Spacer
29	140494	Brake, Rod	85	17541020	Screw #10-24 x 1-1/4
30	19131616	Washer 13/32 x 1 x 16 Ga.	86	140462	Fan 7" Hydro
33	12000053	Ring E	87	140491	Adapter Fan
34	124236X	Cap, Plunger	88	161592	Pulley Idler
35	137648	Rod, Parking Brake	89	73680700	Nut Crownlock 7/16-14 Unc
36	149412	Spring, Drive Ground	90	140489	Keeper Belt
37	121749X	Washer 25/32 x 1-1/4 x 16 Ga.	91	17490644	Screw Thdrol 3/8-16 x 2-3/4
38	150035	Nyliner	92	74760520	Bolt Fin Hex 5/16-18 x 1.25
39	74321016	Screw, Fin. #10-24 x 1	93	140502	Link Shift Asm
40	5304J	Actuator, Interlock Switch	94	133835	Fastener Christmas Tree
41	73661000	Locknut #10-24	96	141103	Washer Nickel Plated
42	8883R	Cover, Pedal	98	141004	Bracket Shift
46	145170	Retainer, Spring	99	17060624	Screw 3/8-16 x 1-1/2
47	138228	Clutch Rod	100	126881X	Washer Compression
48	72110612	Bolt, Carri. 3/8-16 x 1-1/2 Gr. 5	101	156106	Washer Bellville
50	131494	Pulley, Idler, Flat	104	140480	Bracket Idler
51	STD541437	Nut, Crownlock 3/8-16 UNC	105	17580408	Screw Tap 1/4-20 x 1/2
52	139123	Pulley, Idler, Grooved	106	142918	O-Ring Asm Hydro Gear 70110
53	207J	Washer, Hardened	107	154739	Line Fuel Hydro 15" VGT
54	161590	Clutch, Arm Assembly	108	142917	Cap Asm Vent Hydro Gear 70109
55	105706X	Bearing, Idler	109	140929	Spring Return Brake
56	140218	V-Belt	111	156240	Spacer Shift Lever VGTH
58	74760724	Bolt Fin Hex 7/16-14 x 1-1/2	112	156104	Washer Nylon High Temp
61	140488	Pulley, Transaxle	113	73220700	Nut-Hex ASF 7/16-14 UNC
64	154752	Shaft, Clutch/Brake Pedal	115	123405X	Keeper Belt T/A Gnd Dr
65	67609	Bolt, Shoulder	116	73900500	Nut Lock Hex Flange 5/16-18
66	140296	Washer, Hardened	117	73900600	Nut, Lock Flg. 3/8-16
67	19131312	Washer, Flat	--	163198	Transaxle Hydro Gear 222-3010L
68	STD571812	Pin, Roll			
69	123800X	Washer			
70	164892X428	Console Automatic YT/GT			

NOTE: All component dimensions given in U. S.inches
1 inch = 25.4 mm

STEERING

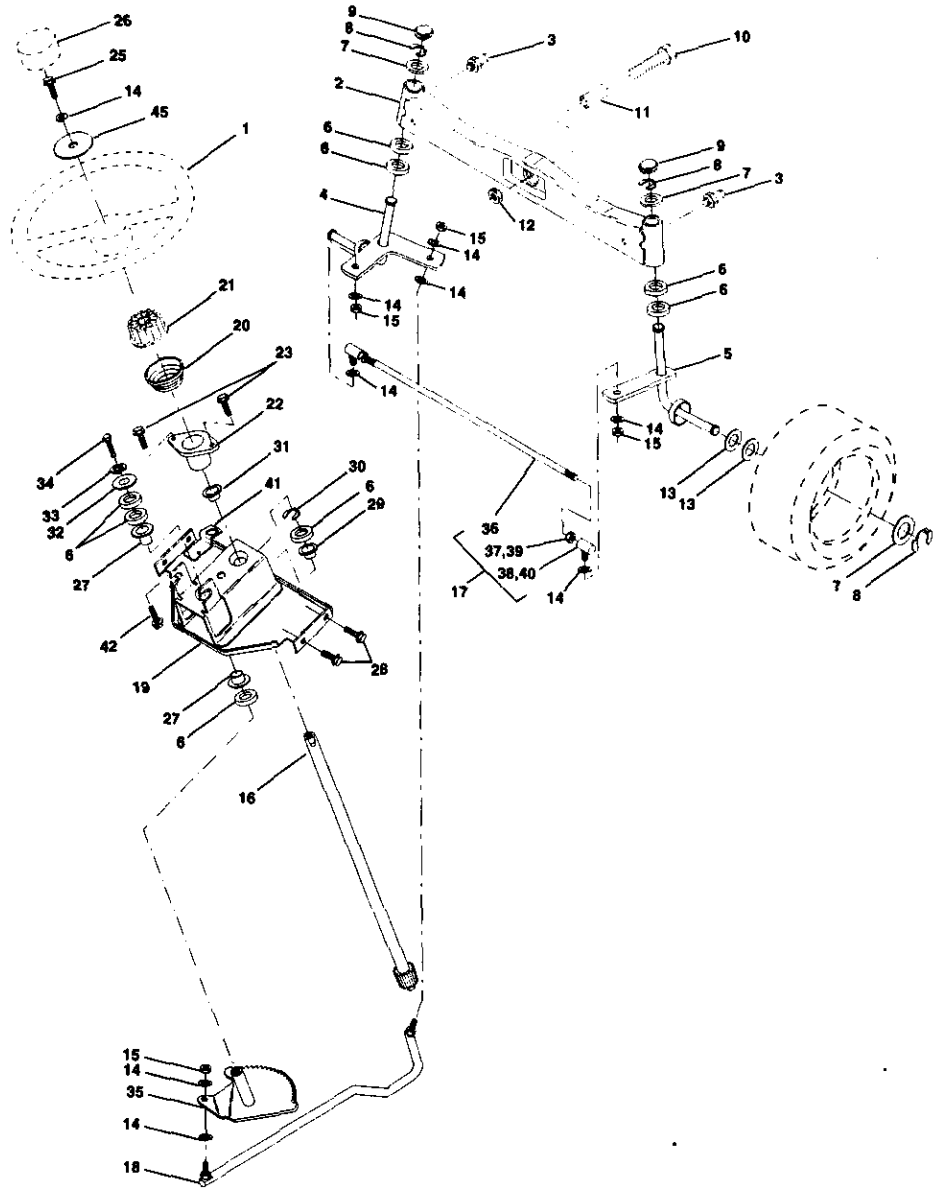

STEERING

TRACTOR -- MODEL NUMBER 917.272960

KEY NO.	PART NO.	DESCRIPTION
1	139768	Wheel, Steering
2	137094	Axle Asm., Front
3	6855M	Fitting, Grease
4	161849	Spindle Asm., LH
5	161848	Spindle Asm., RH
6	6266H	Bearing, Race Thrust Harden
7	121748X	Washer 25/32 x 1-5/8 x 16 Ga.
8	1200029	Ring, Klip #T5304-75
9	121232X	Cap, Spindle
10	74781044	Bolt, Fin Hex 5/8-11 x 2-3/4
11	136518	Spacer Bearing Axle Front
12	73901000	Nut, Lock Flange 5/8-11 Unc
13	121749X	Washer 25/32 x 1-1/4 x 16 Ga.
14	STD551137	Washer, Lock Hvy Hlcl Spr 3/8
15	STD541537	Nut, Lock Center 3/8-24 UNF
16	145103	Shaft Asm., Steering
17	137347	Rod Asm., Tie Ball J Ball Vgt (Inc. Key No. 36-40)
18	137155	Draglink, Ball Joint Solid Vgt
19	156011	Support Asm., Steering Vgt
20	172020	Boot, Steering
21	100711L	Adapter, Wheel Steering
22	155105	Bushing, Strg. Bik
23	152927	Screw
25	74780616	Bolt, Fin Hex 3/8-16 x 1 Gr. 5
26	139769	Cap, Wheel Steering
27	3366R	Bearing, Col. Strg.
28	17000612	Screw 3/8-16 x 3/4
29	104239X	Bearing, Flange
30	12000034	Ring, Klip Truarc #5304-75
31	138136	Bushing, Nylon Snap
32	19111610	Washer 11/32 x 1 x 10 Ga.
33	STD551131	Washer, Lock Hvy Hlcl Spr 5/16
34	74760512	Bolt, Hex Hd 5/16-18 x 3/4
35	138059	Gear, Sector Steering
36	137156	Tie Rod
37	73360600	Jam Nut RH Thread
38	109850X	Joint Asm. Ball RH Thread
39	73700600	Jam Nut LH Thread
40	109851X	Joint Asm. Ball LH Thread
41	155246	Bracket Switch Interlock VGT 97
42	17490508	Screw Thdrol 5/16-18 x 1/2 Tyl
45	19133812	Washer

NOTE: All component dimensions given in U. S. inches
1 inch = 25.4 mm

ENGINE

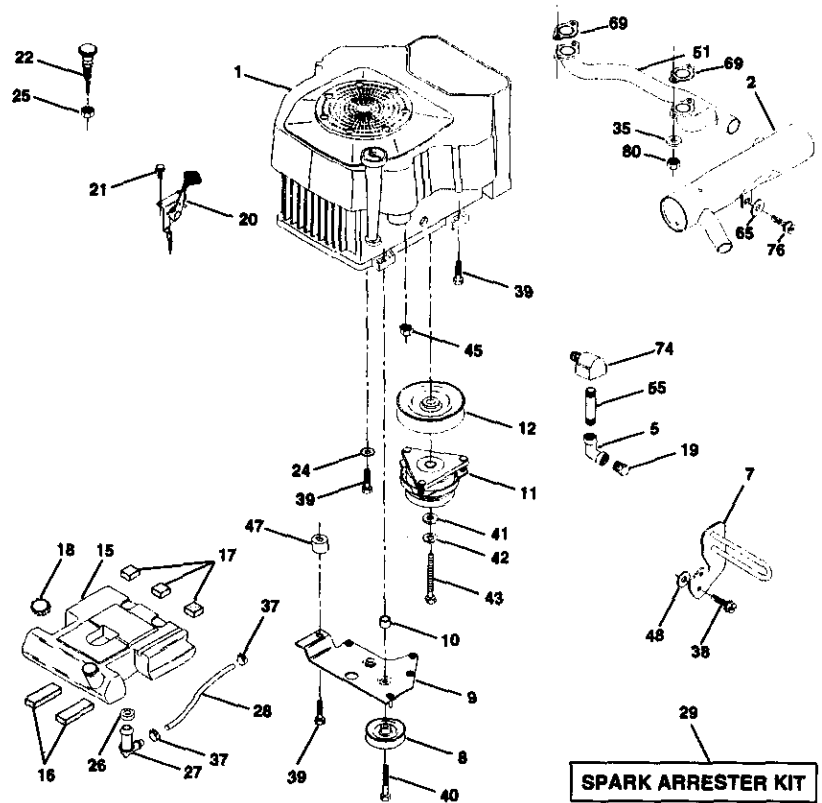

KEY PART NO. NO.

DESCRIPTION

1	-----	Engine (See Breakdown)
2	161063	Muffler
5	13200900	Elbow STD 90 Degree 3/8-18 NPT
7	151396	Muffler Asm Guard
8	121361X	Pulley V-Idler
9	150828	Keeper Asm. Belt Engine
10	105432X	Bushing
11	140923	Clutch Electric
12	143996	Pulley Engine VGT Elect Clutch
15	151346	Tank Fuel Rear 3.50 Y/Gt 96
16	109227X	Pad Spacer
17	106082X	Pad Spacer
18	140527	Cap Asm Fuel W/Gauge
19	13290300	Plug Oil Drain (See Engine Breakdown)
20	164067	Control Throttle
21	164863	Screw Hwtd HI-Lo #13-16 x 3/4
22	164415	Control Choke
24	STD551237	Washer Ext Tooth 3/8
25	73920600	Nut Keps 3/8 - 24 UNF
26	3645J	Bushing
27	139277	Stem Tank Fuel
28	7834R	Fuel Line
29	132920	Spark Arrester Kit

KEY PART NO. NO.

DESCRIPTION

33	STD541437	Nut Lock Hex w/Ins. 3/8 - 16
35	10010500	Washer Spilt
37	123487X	Clamp Hose
38	17060620	Screw 3/8-16 x 1-1/4
39	17490636	Screw TT 3/8-16 x 2-1/4 UNC
40	17490664	Screw TT 3/8-16 x 4 UNC
41	126197X	Washer 1-1/2 OD X 15/32 ID X .250
42	STD551143	Washer Lock 7/16
43	150280	Bolt Hex 7/16 - 20 X 4 - 1/4 Ga 5
45	73510400	Nut Keps Hex 1/4-20 Unc
47	142040	Spacer Engine
48	19132007	Washer 13/32 x 1-1/4 x 7 Ga.
51	161231	Manifold Pipe VGT
54	19131414	Washer Flat 13/32 x 7/8 x 14 Ga.
55	13280336	Nipple Pipe 4-1/2
64	17000612	Screw 3/8-16 x 3/4
65	19131614	Washer 13/32 x 1 x 14 Ga.
69	24-041-02	Gasket Kohler CV18-CV26
74	162295	Elbow Street Brass
80	M73030800	Nut Flange M8-1.25 Non-Lk Zink

NOTE: All component dimensions given in U. S. inches
1 inch = 25.4 mm

TRACTOR -- MODEL NUMBER 917.272960
SEAT ASSEMBLY

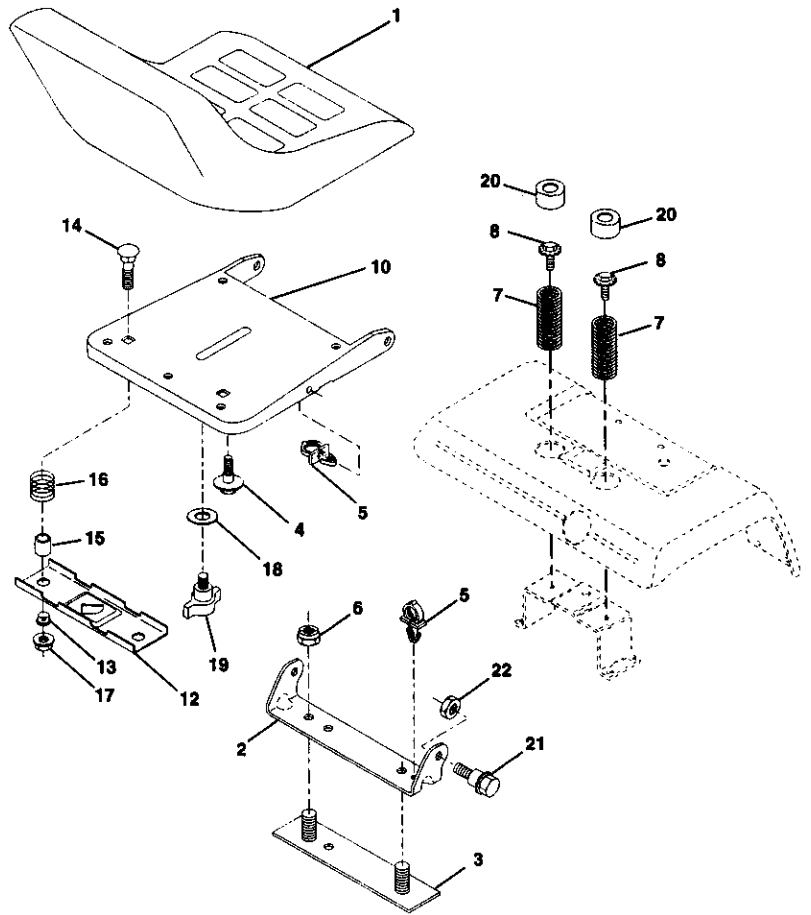

KEY PART NO.	NO.	DESCRIPTION
1	140123	Seat
2	140551	Bracket, Pivot Seat
3	140675	Strap, Fender
4	127018	Bolt, Shoulder 5/16-18 x .62
5	145006	Clip, Push In, Hinged
6	STD541437	Nut, Crownlock 3/8-16 Unc
7	124181X	Spring, Seat Cprsn
8	171877	Bolt 5/16-18 Unc x 3/4 w Sems
10	155925	Pan, Seat
12	121246X	Bracket, Mounting Switch
13	121248X	Bushing, Snap

KEY PART NO.	NO.	DESCRIPTION
14	72050412	Bolt, Carriage 1/4-20 X 1-1/2
15	134300	Spacer, Split
16	121250X	Spring, Cprsn
17	123976X	Nut, Lock 1/4 Lge Flg Gr. 5
18	19171912	Washer 17/32 x 1-3/16 x 12 Ga.
19	166369	Knob, Seat
20	124238X	Cap, Spring Seat
21	171852	Bolt, Shoulder 5/16-18
22	STD541431	Nut, Crownlock 5/16-18 Unc

NOTE: All component dimensions given in U. S. inches
1 inch = 25.4 mm

DECALS

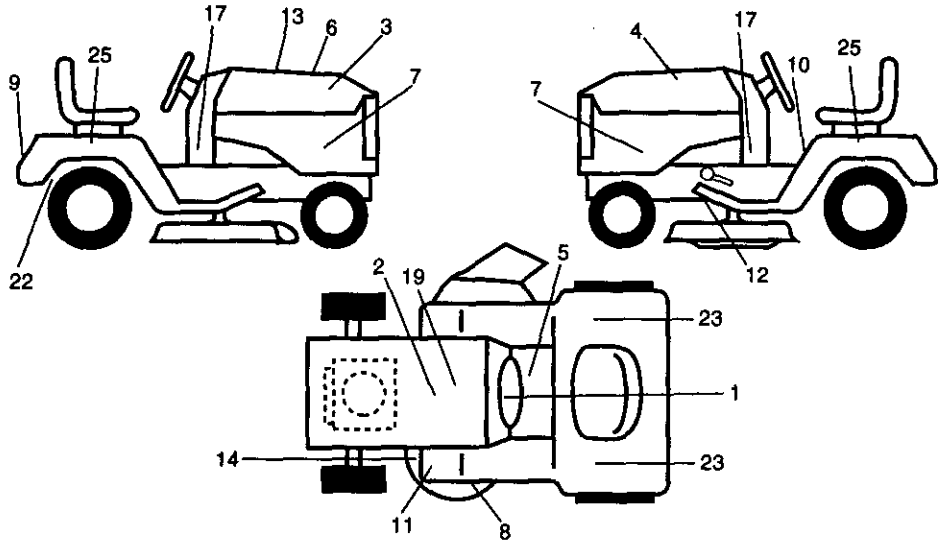

KEY PART NO.	NO.	DESCRIPTION
1	164094	Decal Dash
2	149516	Decal Battery DNGR/PSN ENG Asm
3	171702	Decal Hood RH Craftsman
4	171703	Decal Hood LH Craftsman
5	140837	Decal Brake Parking Saddle
6	133644	Decal Maintenance
7	171705	Decal Side Panel
8	133179	Decal Housing Mower
9	163204	Decal Fender Craftsman
10	156439	Decal Fender Danger
11	4900J	Decal Clutch/Brake
12	146790	Decal V-Belt Dr Sch

KEY PART NO.	NO.	DESCRIPTION
13	171812	Decal RPLC
14	160397	Decal V-Belt Schem
17	172507	Decal Dash Panel
19	138047	Decal Battery
22	142342	Decal Drawbar CNTRL
23	106202X	Reflector, Taillight
25	163230	Decal Fender Auto Trans
--	138311	Decal Handle Lft Height Adjust (Lift Handle)
--	157199	Pad Footrest
--	172013	Owner's Manual, English
--	172014	Owner's Manual, Spanish

WHEELS AND TIRES

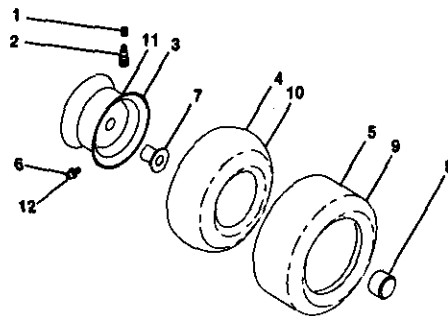

KEY PART NO.	NO.	DESCRIPTION
1	59192	Cap Valve Tire
2	65139	Stem Valve
3	106228X427	Rim Asm Front
4	8134H	Tube, Front (Service Item Only)
5	106230X	Tire, Front
6	278H	Fitting Grease (Front Wheel Only)
7	9040H	Bearing Flange (Front Wheel Only)
8	104757X	Cap Axle (Front Wheel Only)
9	140183	Tire Rear
10	7154J	Tube Rear (Service Item Only)
11	106227X427	Rim Asm Rear
12	6856M	Fitting Grease
--	144334	Sealant, Tire (10 oz. Tube)

NOTE: All component dimensions given in U. S.inches
1 inch = 25/4 mm

TRACTOR -- MODEL NUMBER 917.272960

LIFT ASSEMBLY

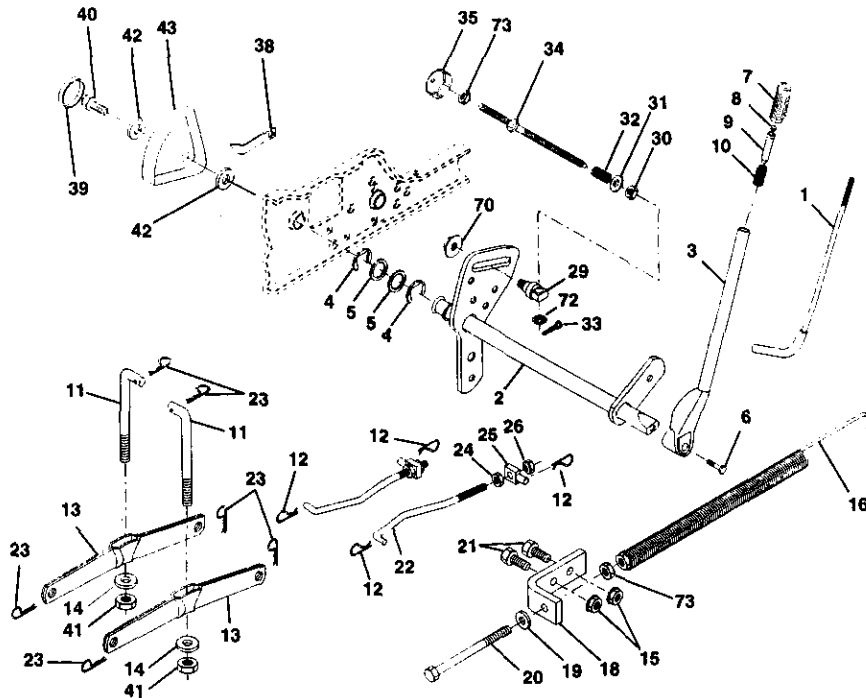

**KEY PART
NO. NO.**

DESCRIPTION

1	121006X	Rod Asm., Lever
2	159187	Shaft Asm., Lift Vgt
3	159189	Lever Asm., Lift Rh
4	12000022	E-Ring Truarc #5133-87
5	19292016	Washer 29/32 x 1-1/4 x 16 Ga.
6	71110624	Bolt, Fin Hex 3/8-16 x 1-1/2
7	125631X	Grip, Handle Fluted
8	122365X	Button, Plunger
9	122364X	Plunger, Button
10	2876H	Spring 2-1/8"
11	146704	Link Lift
12	163552	Retainer, Spring
13	139868	Arm, Suspension Vgt
14	140302	Bearing
15	STD541437	Nut, Crownlock 3/8-16 Unc
16	674A247	Spring Asm., Assist Lift
17	STD541237	Nut, Hex Jam 3/8-16 Unc
18	143363	Bracket, Spring Assist
19	STD551037	Washer 13/32 x 13/16 x 16 Ga.
20	5328J	Bolt, Adjust Spring Assist
21	STD523710	Bolt, Fin Hex 3/8-16 x 1
22	127218	Link, Front

**KEY PART
NO. NO.**

DESCRIPTION

23	STD624008	Retainer, Spring
24	73350800	Nut, Jam Hex 1/2-13 Unc
25	130171	Trunnion
26	73680800	Nut Crownlock 1/2-13 Unc
29	150233	Trunnion, Infin Height
30	110807X	Nut, Special
31	STD551037	Washer 13/32 x 5/8 x 16 Ga.
32	137150	Spring, Compression Inf Hgt
33	STD560907	Pin, Cotter 3/32 x 1/2
34	137167	Rod, Adj Lift
35	138057	Knob, Inf 3/8-16 Unc
38	155097	Pointer, Height Indicator
39	123935X	Plug, Hole
40	17490512	Screw Hex Wsh 5/16-18 x 3/4
41	73540600	Nut, Crownlock 3/8-24
42	19112410	Washer 11/32 x 1-1/2 x 10 Ga.
43	123934X	Scale, Indicator Height
70	145212	Nut Hex Flange Lock
72	110452X	Nut Push Phos & Oil

NOTE: All component dimensions given in U. S. inches
1 inch = 25.4 mm

MOWER DECK

TRACTOR - MODEL NUMBER 917.272960

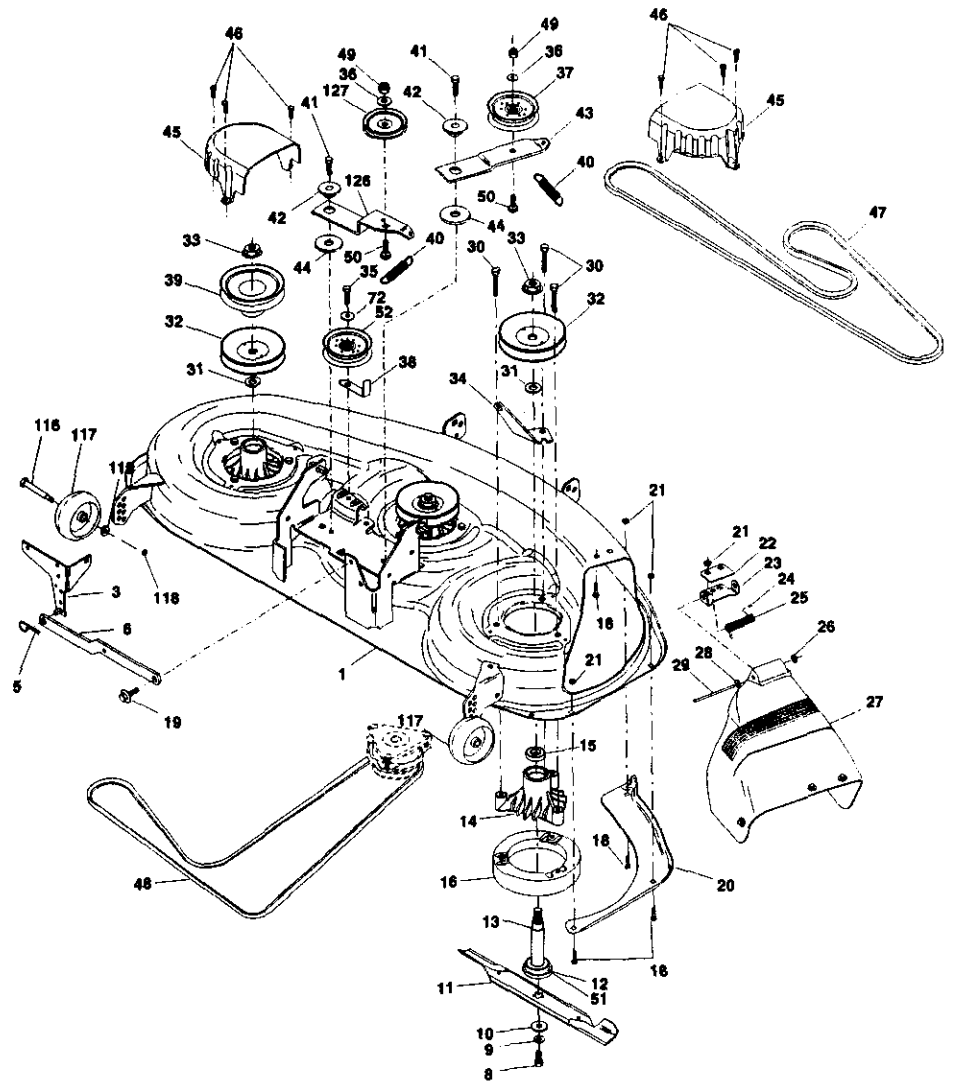

TRACTOR -- MODEL NUMBER 917.272960

MOWER DECK

KEY PART NO.	NO.	DESCRIPTION	KEY PART NO.	NO.	DESCRIPTION
1	156948	Deck Weldment Mower 46	37	131494	Pulley, Idler, Flat
3	138457	Bracket Asm., Sway Bar	38	156086	Keeper, Belt, Idler
5	4939M	Retainer Spring	39	144917	Pulley, Idler, Driven
6	130832	Arm, Suspension, Rear (Sway Bar)	40	137273	Spring, Secondary 44/46/50 Vent
8	850857	Bolt, Patch 3/8-24 x 1-1/4 Gr. 8	41	17060620	Screw 3/8-16 x 1-1/4
9	STD551137	Washer, Lock Hvy. Unplated 3/8	42	165723	Spacer, Retainer
10	140296	Washer, Hard Blade, Mower Vented	43	144949	Arm, Idler Secondary
11	170698	Blade, 46"	44	133943	Washer, Hardened
12	129895	Bearing, Ball, Mandrel #6204	45	145059	Cover, Mandrel Deck
13	137553	Shaft Asm. w/Lower Bearing (Includes Key No. 12)	46	137729	Screw, Thdroll. 1/4-20 x 5/8
14	137152	Housing, Mandrel	47	144959	V-Belt, Mower, Secondary
15	110485X	Bearing, Ball, Mandrel	48	148763	V-Belt, Mower, Primary
16	140329	Stripper, Mower Round	49	73680600	Nut, Crownlock 3/8-16 UNC
18	72140505	Bolt, Carriage 5/16-18 x 5/8	50	72110612	Bolt, Carr. 3/8-16 x 1-1/2 Gr. 5
19	132827	Bolt, Hex Hd, Shoulder 5/16-18	51	153390	Washer, Felt
20	145055	Baffle, Vortex Mower 46"	52	156493	Pulley Idler 46 Pri Drive 97
21	73680500	Nut, Crownlock 5/16-18 UNC	57	156941	Pin Head Rivet
22	134753	Stiffener, Bracket	72	19131616	Washer 13/32 x 1 x 16 Ga.
23	131267	Bracket, Deflector	116	137644	Bolt, Shoulder
24	105304X	Cap, Sleeve	117	133957	Gauge Wheel, Wide
25	149287	Spring, Torsion, Deflector	118	73930600	Nut, Centerlock 3/8-16 UNC
26	110452X	Nut, Push	119	19121414	Washer 3/8 x 7/8 x 14 Ga.
27	166883X428	Deflector Clipping	126	144948	Arm, Idler, Primary Deck 46"
28	19111016	Washer 11/32 x 5/8 x 16 Ga.	127	146763	Pulley, Idler, V-Groove Dim. 4.25
29	131491	Rod, Hinge	--	166209	Deck Complete (Std. Deck- Order separately mulcher plate and gauge wheel components Key Nos. 101-106 and 116-118)
30	157722	Screw, Thdroll Washer Head	--	143651	Mandrel Asm. Service (Includes Key Nos. 8-10, 12-15, 31 and 33)
31	129963	Washer, Spacer Mower Vented			
32	153531	Pulley, Mandrel			
33	137266	Nut, Fig. Top Lock Cntr. 9/16			
34	144945	Anchor, Spring Deck 46"			
35	17490628	Screw, Thdroll 3/8-16 x 1-3/4 Tytt			
36	19131316	Washer 13/32 x 13/16 x 16 Ga.			

NOTE: All component dimensions given in U. S. inches
1 inch = 25.4 mm

TRACTOR - MODEL NUMBER 917.272960
TRANSAXLE - MODEL NUMBER 222-3010L

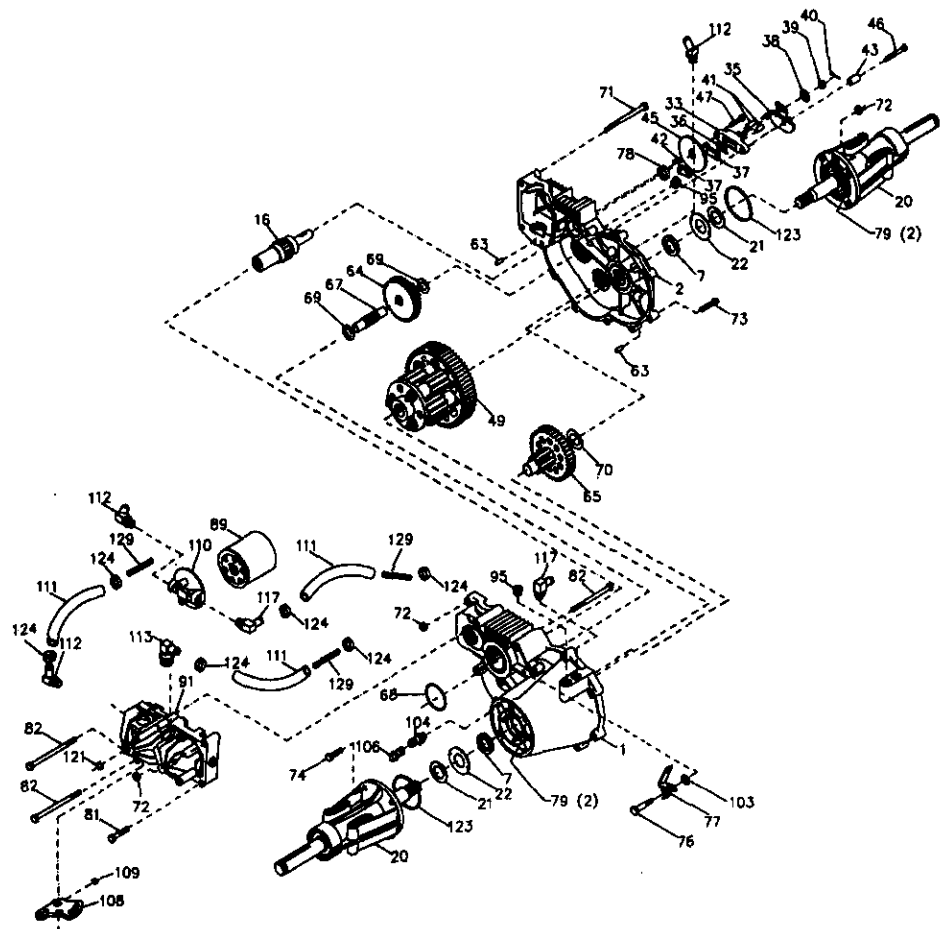

**TRACTOR -- MODEL NUMBER 917.272960
TRANSAXLE--MODEL NUMBER 222-3010L**

KEY NO.	PART NO.	DESCRIPTION	KEY NO.	PART NO.	DESCRIPTION
1	164591	Assembly, Housing, LH	72	153767	Locknut, Hex 5/16-18
2	164592	Assembly, Housing, RH	73	142904	Bolt, Hex 5/16-18 x 1-1/2
7	153765	Oil Seal .984 x 1.5 x .25	74	142905	Hex Cap Screw 5/16-18 x 1
16	142876	Brake Shaft Assembly	76	142907	Shoulder Bolt
20	142877	Axle Mounting Horn Assembly	77	142908	Freewheel Actuating Arm
21	142878	Washer 1.0 x 1.63 x .08	78	142909	Oil Seal .625 x 1.0 x .25
22	142879	Washer 1.0 x 2.06 x .09	79	153768	Grease (10 oz. Tube)
33	142929	Brake Yoke Assembly	81	142910	Bolt, Hex 5/16-18 x 1-3/4
35	142880	Brake Arm	82	142911	Bolt 5/16-18 x 4-1/2
36	142882	Puck Plate	89	142912	Filter, Spin On
37	142883	Brake Puck	91	153769	Pump, BDU-10L-122
38	142884	Washer 7/8 O.D. x 7/16 x .060	95	142914	Plug, Straight Thread
39	142885	Nut, Castle 5/16-24	96	153770	60° 7/18 SAE x 5/16 Fitting
40	142886	Cotter Pin	103	142916	Washer
41	142887	Brake Actuating Pin	104	142917	Vent Cap Assembly
42	142888	Hi Pro Key	106	142918	Fitting O-Ring Assembly
43	142889	Spacer	108	142919	Control Arm
45	142890	Brake Disc	109	142920	Set Screw
46	142891	Bolt 1/4-20 x 1-1/2	110	142921	Filter Head
47	142892	Bolt 1/4-20 x 1	111	150820	Hose 1/2"
49	153766	Differential Assembly	112	150823	Fitting, 1/2" Beaded 90° 7/8 SAE
63	142894	Dowel Pin	113	150821	Fitting, 1/2" Beaded 60° 9/16
64	150818	Reduction Gear, 14 Teeth to 38 Teeth	117	150822	Fitting, 1/2" Beaded 90° 9/16
65	142897	Final Drive Pinion Assembly	123	150824	O Ring
67	142898	Jackshaft	124	150825	Pinch Clamp
68	142899	O-Ring	129	153771	Spring, Long
69	142900	Washer 5/8 X 1-5/32			
70	142901	Washer 7/8 X 1-1/2			
71	142902	Bolt, Hex 5/16-18 x 3.5			

NOTE: All component dimensions given in U.S. inches
1 inch = 25.4 mm

TRACTOR -- MODEL NUMBER 917.272960
TRANSAXLE--MODEL NUMBER 222-3010L

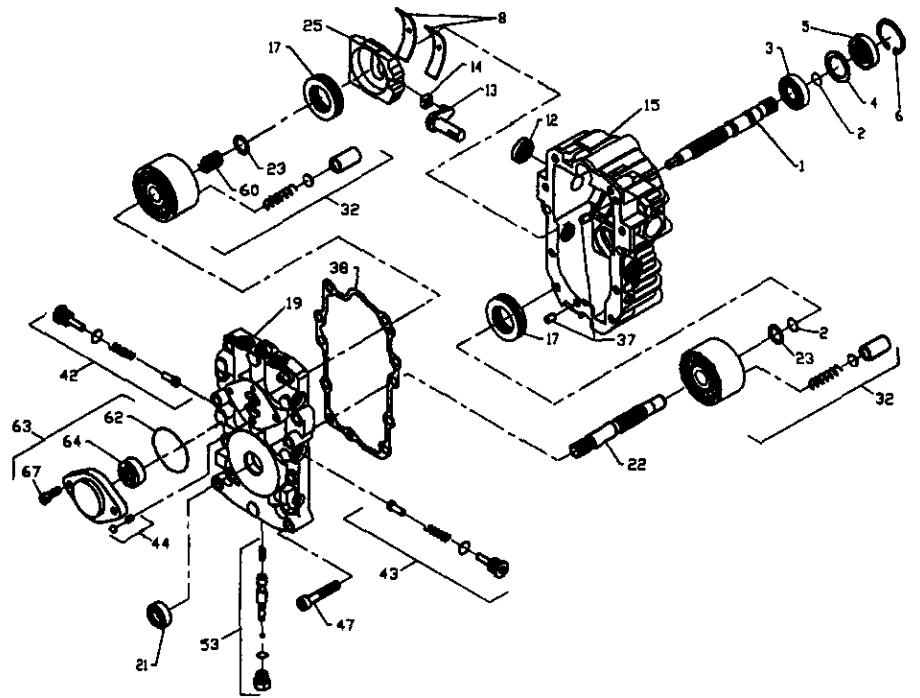

**TRACTOR -- MODEL NUMBER 917.272960
TRANSAXLE--MODEL NUMBER 222-3010L**

KEY NO.	PART NO.	DESCRIPTION
1	144569	Shaft, Pump
2	122716X	Ring, Retaining
3	122745X	Bearing, Ball
4	122715X	Spacer
5	122700X	Seal, Lip
6	122699X	Ring, Retaining
8	122767X	Bearing, Cradle
12	122717X	Seal, Lip
13	122748X	Arm, Trunnion
14	122749X	Guide, Slot
15	144571	Housing Kit, Transmission
17	122770X	Bearing, Thrust, Ball
19	153801	Center Section Kit
21	122722X	Seal, Lip
22	144573	Shaft, Motor
23	142978	Washer, Block Thrust
25	127148X	Swashplate, Variable
32	142938	Block Assembly
37	122786X	Pin, Stainless, Headless
38	122718X	Gasket, Center Section
42	144578	Check Valve Kit
43	144578	Check Valve Kit
44	144579	Charge Relief Kit
47	122752X	Screw, Socket Head, Cap
53	127153X	Bypass Valve Kit
60	142977	Block Spring
62	144581	O-Ring
63	144582	Charge Pump Kit
64	144583	Gerotor Assembly
67	144584	Screw, Socket Head, Cap
--	153769	Pump Assembly, Complete

NOTE: All component dimensions given in U.S. inches
1 inch = 25.4 mm

TRACTOR -- MODEL NUMBER 917.272960
KOHLER ENGINE-MODEL NUMBER CV20S, TYPE NUMBER 65561

CYLINDER HEAD, VALVE AND BREATHER

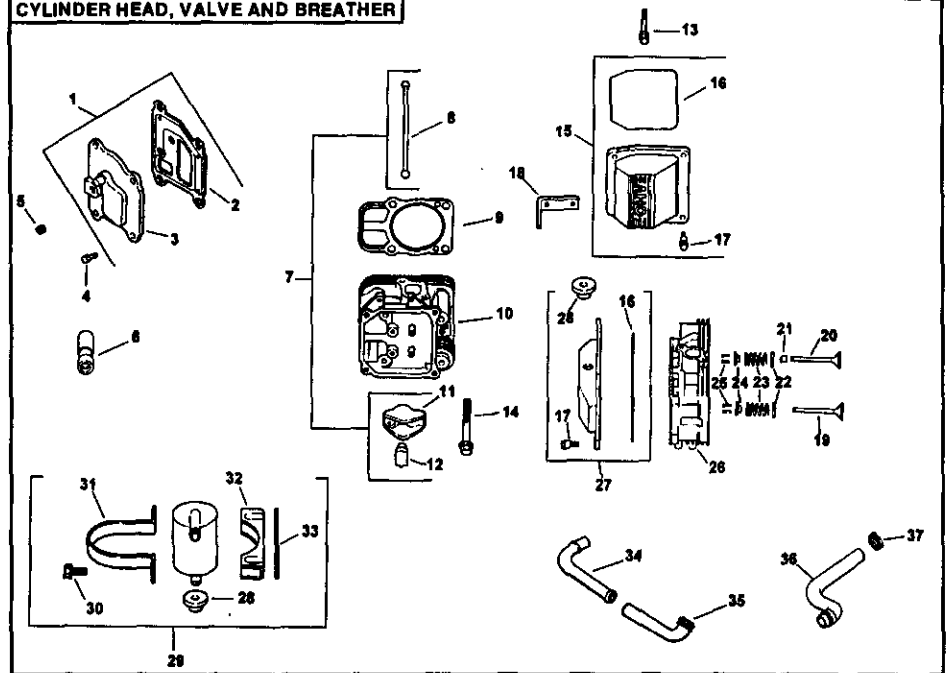

CRANKCASE

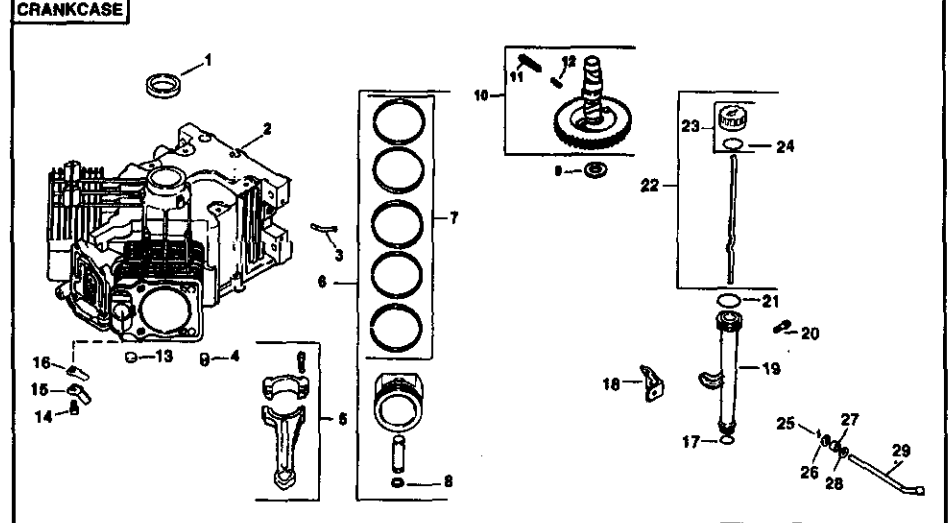

**TRACTOR -- MODEL NUMBER 917.272960
KOHLER ENGINE-MODEL NUMBER CV20S, TYPE NUMBER 65561**

HEAD/VALVE/BREATHER

KEY PART NO.	PART NO.	DESCRIPTION
1	24-033-03-S	Kit, breather cover w/ gasket (Includes 2,3)
2	24-041-23-S	Gasket, breather
3	24-096-59-S	Cover, breather
4	M-645020	Screw, hex. flange M6x1.0x20 (4)
5	X-75-23-S	Plug, allen hd. 1/8"
6	25-351-01-S	Lifter, valve (4)
7	24-755-66-S	Kit, valve train (Includes 8,11,12)
8	24-411-05-S	Rod, push (4)
9	24-041-08-S	Gasket, cylinder head (2)
10	24-318-12-S	Head assembly, #2 cylinder
11	25-186-01-S	Arm, rocker (4)
12	24-599-01-S	Pivot, rocker arm (4)
13	M640034-S	Screw, hex. flange M6x1.0x34 (4)
14	12-086-16-S	Screw, hex. flange M10x1.5x90 (8)
15	24-755-7-S	Kit, valve cover - plain (Includes 16,17)
16	24-153-16-S	O-Ring
17	24-086-32-S	Screw, shoulder (4)
18	24-445-01-S	Strap, lifting
19	24-016-01-S	Valve, exhaust (Std.) (2)
	24-016-02-S	Valve, exhaust (.25) (2)
20	24-017-01-S	Valve, intake (Std.) (2)
	24-017-02-S	Valve, intake (.25) (2)
21	24-032-05-S	Seal, valve stem (2)
22	235011-S	Retainer, spring (4)
23	24-089-02-S	Spring, valve (4)
24	12-173-01-S	Cap, valve spring (4)
25	12-755-03-S	Kit, retainer (4)
26	24-318-11-S	Head assembly, #1 cylinder
27	24-755-76-S	Kit, valve cover - breather (Incl. 16,17,28)
28	25-313-02-S	Grommet, rubber
29	24-755-57-S	Kit, breather separator (Includes 28,30-33)
30	M-545016-S	Screw, hex. flange M5x0.8x16 (2)
31	24-445-02-S	Strap, breather
32	24-126-44-S	Bracket, breather separator
33	24-112-12-S	Spacer
34	24-294-06-S	Fitting
35	24-326-13-S	Hose, breather
36	24-326-14-S	Hose, breather
37	X-426-9-S	Clamp, hose (2)

CRANKCASE

KEY PART NO.	PART NO.	DESCRIPTION
1	24-032-01-S	Seal, oil front
2		Crankcase (USE: Miniblock 24 782 05)
3	24-294-13-S	Fitting
4	12-380-17-S	Pin, dowel locating (6)
5	24-067-13-S	Connecting Rod (Std.) (2)
	24-067-14-S	Connecting Rod (.25) (2)
6	24-874-01-S	Piston w/Ring Set (Std.) (2) (Includes 7,8)
	24-874-02-S	Piston w/Ring Set (.25) (2)
	24-874-03-S	Piston w/Ring Set (.50) (2)
	24-874-14-S	Piston w/ring set (.08)
7	24-108-01-S	Ring Set (Std.) (2)
	24-108-02-S	Ring Set (.25) (2)
	24-108-03-S	Ring Set (.50) (2)
8	24-018-01-S	Retainer, piston pin (4)
9	12-422-09-S	Shim, camshaft (A.R.)
	12-422-13-S	Shim, camshaft (A.R.)
	12-422-07-S	Shim, camshaft (A.R.)
	12-422-08-S	Shim, camshaft (A.R.)
	12-422-10-S	Shim, camshaft
	12-422-11-S	Shim, camshaft (A.R.)
	12-422-12-S	Shim, camshaft (A.R.)
10	24-010-06-S	Camshaft (Includes 11,12)
11	24-089-35-S	Spring acr (Heavy)
12	24-089-34-S	Spring acr (light)
13	52-139-09-S	Plug, cup
14	M-545010-S	Screw, hex. flange M5x0.8x10 (2)
15	24-018-04-S	Retainer, reed (2)
16	24-402-05-S	Reed, breather (2)
17	12-153-01-S	O-Ring, lower oil fill tube
18	24-126-19-S	Bracket, oil fill tube
19	12-123-04-S	Tube, oil fill
20	M-545016-S	Screw, hex. flange M5x0.8x16
21	12-153-02-S	O-Ring, upper oil fill tube
22	24-038-04-S	Dipstick assembly (Includes 22,23)
23	24-755-46-S	Kit, oil fill cap (Includes 23)
24	12-153-03-S	O-Ring, dipstick
25	12-380-04-S	Pin, hitch
26	M-631005-S	Washer, plain 6 mm
27	12-032-01-S	Seal, governor cross shaft
28	X-25-102-S	Washer, plain 1/4"
29	24-144-01-S	Shaft, governor cross

TRACTOR -- MODEL NUMBER 917.272960
KOHLER ENGINE-MODEL NUMBER CV20S, TYPE NUMBER 65561

IGNITION/ELECTRICAL

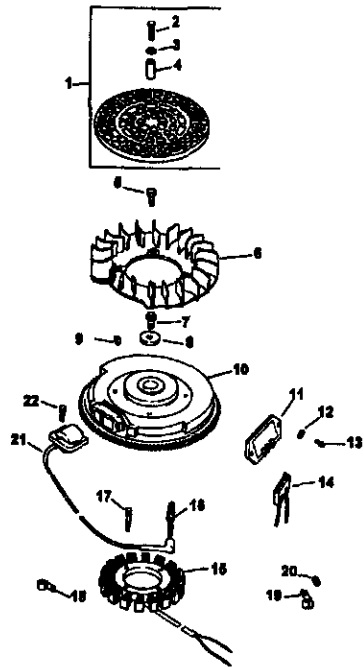

BLOWER HOUSING AND BAFFLES

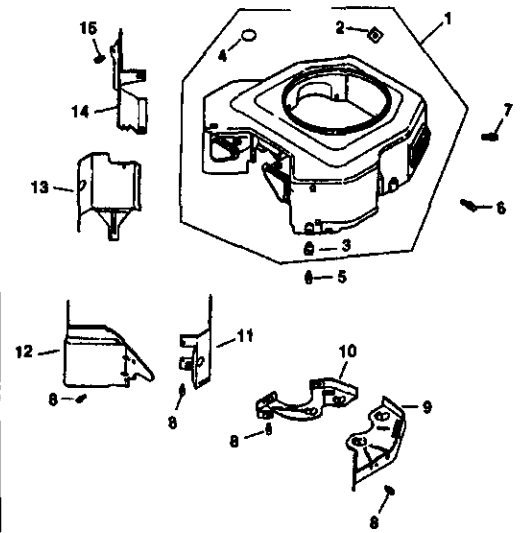

AIR INTAKE

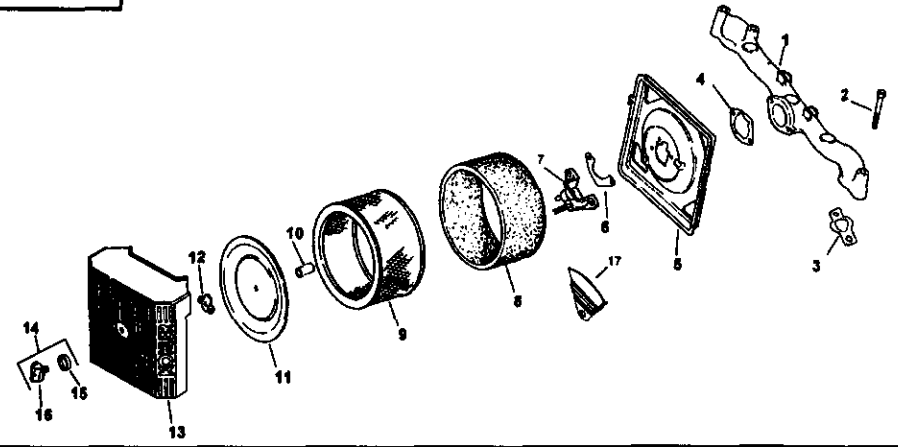

**TRACTOR -- MODEL NUMBER 917.272960
 KOHLER ENGINE-MODEL NUMBER CV20S, TYPE NUMBER 65561**

IGNITION/CHARGING

KEY PART NO.	NO.	DESCRIPTION
1	54-755-15-S	Kit, grass screen (Includes 2-4, and 24, 113, 18)
2	M-403025-S	Screw, hex. cap M4x0.7x25 (4)
3	X-25-92-S	Washer, plain 5/16" (4)
4	24-112-04-S	Spacer, grass screen (4)
5	25-086-47-S	Bolt, shoulder (4)
6	24-157-03-S	Fan
7	12-086-14-S	Screw, hex. flange M10x1.5x46
8	12-468-03-S	Washer, plain 3/8"
9	X-42-15-S-	Key
10	24-025-04-S	Flywheel
11	25-403-03-S	Rectifier-regulator
12	X-25-92-S	Washer, plain 3/16" (2)
13	24-086-18-S	Screw, phillips hd. 11-16 x 7/8 (2)
14	236602-S	Connector (3 contact)
15	54-755-09-S	Kit, 15 amp stator (Includes 24 126 71)
16	12-132-06-S	Spark Plug (2)
17	M-548025-S	Screw, hex. cap M5x0.8x25 (2)
18	235173-S	Clip, cable
19	48-154-02-S	Clip, cable
20	X-25-63-S	Washer, plain 1/4"
21	24-584-01-S	Module, ignition (2)
22	M-545020-S	Screw, hex. flange M5x0.8x20 (4)
NOT ILLUSTRATED		
--	24-126-71-S	Bracket, stator wire
--	X-22-11-S	Washer, lock 1/4"
--	24-176-79-S	Harness, wiring Lead, black (rect.-reg. 5" - 12 gauge insulated grip barrel eyelets)
--	24-518-12-S	
--	24-113-18-S	Decal, grass screen
--	25-454-03-S	Tie, wire (3)

BLOWER HOUSING & BAFFLES

KEY PART NO.	NO.	DESCRIPTION
1	24-027-20-S	Housing, blower (Incl. 2-4)
2	24-100-01-S	Nut plastic (3)
3	25-139-16-S	Plug, button 9/16
4	24-100-02-S	Nut, plastic (2)
5	M-545020-S	Screw, hex. flange M5x0.8x20 (4)
6	M-545016-S	Screw, hex. flange M5x0.8x16 (3)
7	M-551016-S	Screw, hex. flange M5x0.8x16
8	M-645016-S	Screw, hex. flange M6x1.0x16 (6)
9	24-146-16-S	Plate, backing - # 2 side
10	24-146-20-S	Plate, backing - # 1 side
11	24-063-20-S	Baffle, cylinder barrel-# 2 side
12	24-063-14-S	Baffle, valley - #2 side
13	24-063-30-S	Baffle, cylinder barrel-# 1 side
14	24-063-23-S	Baffle, valley - #1 side
15	M-545010-S	Screw, hex. flange M5x0.8x10 (2)

AIR INTAKE/FILTRATION

KEY PART NO.	NO.	DESCRIPTION
1	24-164-06-S	Manifold, intake
2	M-651055-S	Screw, hex. flange M6x1.0x55 (4)
3	24-041-01-S	Gasket, intake manifold (2)
4	24-041-14-S	Gasket, air cleaner base
5	24-094-19-S	Base, air cleaner
6	24-041-13-S	Gasket, fuel spitback cup
7	24-109-10-S	Cup, fuel spitback
8	24-083-02-S	Pre-cleaner, element
9	47-083-03-S	Element, air cleaner
10	24-032-03-S	Seal, breather
11	24-096-01-S	Cover, inner air cleaner
12	12-100-01-S	Wing Nut
13	24-096-67-S	Cover, air cleaner
14	54-755-01-S	Kit, knob with seal (Includes 15 & 16)
15	24-153-15-S	O-Ring
16	25-341-03-S	Knob, cover
17	24-063-51-S	Baffle, fuel spitback

STARTING SYSTEM

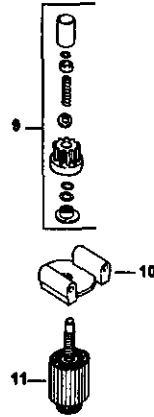
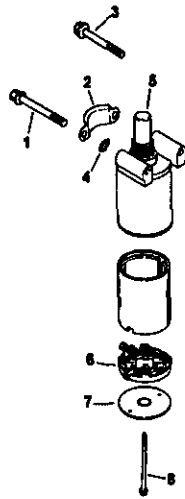

ENGINE CONTROLS

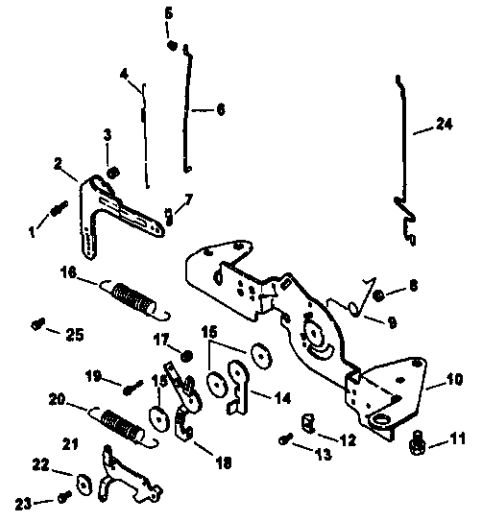

OIL PAN / LUBRICATION

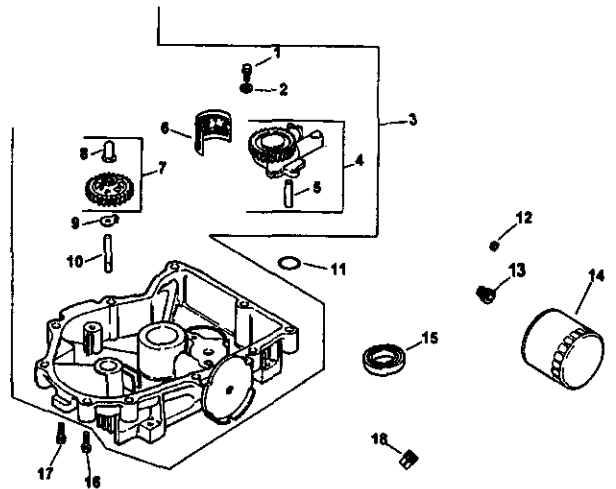

**TRACTOR -- MODEL NUMBER 917.272960
KOHLER ENGINE-MODEL NUMBER CV20S, TYPE NUMBER 65561**

STARTING SYSTEM

KEY PART NO.	NO.	DESCRIPTION
1	M-839070-S	Screw, hex. flange M8x1.25x70
2	24-096-05-S	Cover, pinion
3	M-839080-S	Screw, hex. flange M8x1.25x80
4	12-468-01-S	Washer, plain 11/32" (3)
5	25-098-05-S	Starter, (Includes 6-11)
6	12-221-01-S	Kit, brush
7	12-227-13-S	Cap
8	12-211-01-S	Bolt, thru (2)
9	12-755-54-S	Kit, drive
10	12-227-06-S	Cap, drive end
11	12-170-05-S	Armature

ENGINE CONTROLS

KEY PART NO.	NO.	DESCRIPTION
1	SM-642025-S	Screw, hex. flange M6x1.0x25
2	24-090-14-S	Lever, governor
3	M-641060-S	Nut, hex. flange M6x1.0
4	24-089-01-S	Spring, linkage
5	25-158-08-S	Bushing, linkage retaining
6	24-079-04-S	Linkage, throttle
7	25-158-11-S	Bushing, throttle linkage
8	M-547050-S	Nut, hex. lock M5x0.8
9	24-089-03-S	Spring, choke return
10	24-126-56-S	Bracket, control
11	M-645016-S	Screw, hex. flange M6x1.0x16 (4)
12	12-237-01-S	Clamp, cable (2)
13	M-545016-S	Screw, hex. flange M5x0.8x16 (1)
14	24-090-07-S	Lever, throttle actuator
15	24-468-01-S	Washer, plain 5.5 mm (3)
16	24-089-18-S	Spring, governor
17	M-446030-S	Nut, hex M4x0.7
18	24-090-13-S	Lever, throttle control
19	M-545020-S	Screw, hex. flange M5x0.8x20
20	24-089-51-S	Spring, throttle limiter
21	24-090-05-S	Lever, choke
22	41-468-03-S	Washer, spring 1/4"
23	M-403025-S	Screw, hex. cap M4x0.7x25
24	24-079-05-S	Linkage, choke
25	24-086-43-S	Screw, thread forming (2)

OIL PAN/LUBRICATION

KEY PART NO.	NO.	DESCRIPTION
1	M-645025-S	Screw, hex. flange M6x1.0x25 (2)
2	M-631005-S	Washer, plain 6 mm (2)
3	24-199-07-S	Pan, oil assembly (Includes 1,2, & 4-10)
4	24-393-08-S	Oil pump assembly (Includes 5)
5	24-123-05-S	Tube, oil pickup
6	24-162-26-S	Screen, oil
7	24-043-12-S	Kit, governor gear w/pin (Includes 8)
8	12-380-01-S	Pin, governor regulating
9	52-448-02-S	Tab, locking
10	12-144-02-S	Shaft, governor gear
11	24-153-08-S	O-Ring
12	X-75-32-S	Plug, hex. ctsk. 3/8"
13	24-136-01-S	Nipple, oil filter
14	12-050-01-S	Filter, oil
15	52-032-08-S	Seal, oil (PTO end)
16	24-086-17-S	Screw, hex. flange M8x1.25x45
17	24-086-16-S	Screw, hex. flange M8x1.25x45 (9)
18	X-75-10-S	Plug, sq. hd. solid 3/8" N.P.T.F.

CRANKSHAFT

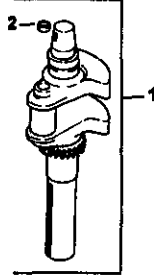

EXHAUST

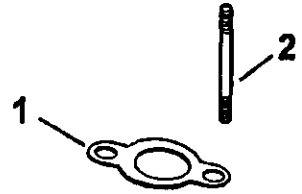

FUEL SYSTEM

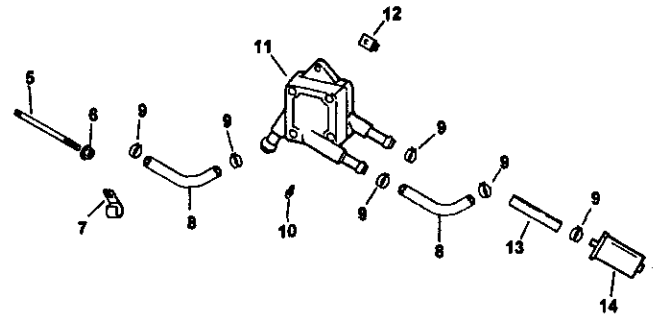
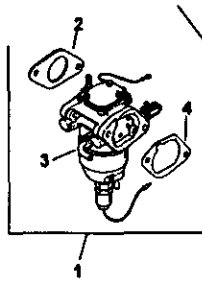

**TRACTOR -- MODEL NUMBER 917.272960
 KOHLER ENGINE-MODEL NUMBER CV20S, TYPE NUMBER 65561**

CRANKSHAFT

KEY PART NO.	NO.	DESCRIPTION
1	24-014-72-S	Crankshaft (Includes 2)
2	52-139-09-S	Plug, cup

EXHAUST

KEY PART NO.	NO.	DESCRIPTION
1	24-041-02-S	Gasket, exhaust (2)
2	25-072-04-S	Stud, M8x1.25x33 (4)

NOT ILLUSTRATED

--	24-522-16	Short Block
--	24-782-05	Miniblock
--	24-755-03-S	Gasket Set

FUEL SYSTEM

KEY PART NO.	NO.	DESCRIPTION
1	24-853-25-S	Kit, carburetor w/gaskets (Includes 2-4)
2	24-041-15-S	Gasket, carburetor
3	24-053-25	Carburetor assembly (For information only not available separately) (Includes 24 757 18, 24-757-19, 24-757-20, 24-757-22)
4	24-041-14-S	Gasket, air cleaner base
5	M-629095-S	Stud, M6x1.0x95 (2)
6	M-641060-S	Nut, hex. flange M6x1.0 (2)
7	47-154-01-S	Clip, cable
8	24-353-03-S	Line, fuel 10-5/8" (2)
9	X-426-9-S	Clamp, hose (6)
10	24-086-12-S	Screw, hex. cap. M6x1.7x18 (2)
11	24-393-16-S	Pump, fuel - pulse
12	24-100-01-S	Nut, plastic (2)
13	15-353-04-S	Line, fuel 11-1/2"
14	25-050-03-S	Filter, fuel
NOT ILLUSTRATED		
--	24-757-18-S	Kit, overhaul w/gaskets
--	24-757-19-S	Kit, choke repair w/gaskets
--	24-757-20-S	Kit, gasket
--	24-757-22-S	Kit, solenoid replacement w/gaskets

2

3

4

5

SUGGESTED GUIDE FOR SIGHTING SLOPES FOR SAFE OPERATION

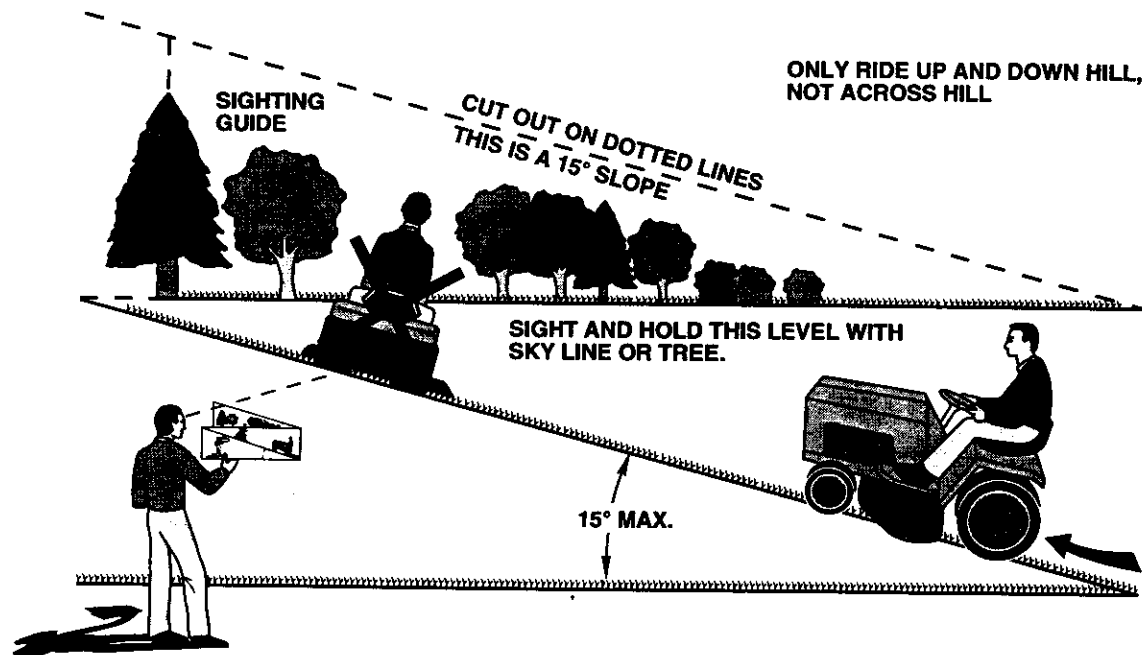

Operate your Tractor up and down the face of slopes (not greater than 15°), never across the face. Make turns gradually to prevent tipping or loss of control. Exercise extreme caution when changing direction on slopes.

Get it fixed, at your home or ours!

For repair of major brand appliances **in your own home...**
no matter who made it, no matter who sold it!

1-800-4-MY-HOMESM Anytime, day or night
(1-800-469-4663)

www.sears.com

To bring in products such as vacuums,
lawn equipment and electronics for repair, call for
the location of your nearest **Sears Parts & Repair Center.**

1-800-488-1222 Anytime, day or night

www.sears.com

For the replacement parts, accessories and owner's manuals
that you need to do-it-yourself, call **Sears PartsDirect**SM!

1-800-366-PART 6 a.m. – 11 p.m. CST,
(1-800-366-7278) 7 days a week

www.sears.com/partsdirect

To purchase or inquire about a Sears Service Agreement:

1-800-827-6655

7 a.m. – 5 p.m. CST, Mon. – Sat.

Para pedir servicio de reparación a domicilio,
y para ordenar piezas con entrega a domicilio:

1-888-SU-HOGARSM
(1-888-784-6427)

Au Canada pour service en français:

1-877-LE-FOYERSM
(1-877-533-6937)



© Sears, Roebuck and Co.

® Registered Trademark / ™ Trademark of Sears, Roebuck and Co.
® Marca Registrada / ™ Marca de Fábrica de Sears, Roebuck and Co.

Free Manuals Download Website

<http://myh66.com>

<http://usermanuals.us>

<http://www.somanuals.com>

<http://www.4manuals.cc>

<http://www.manual-lib.com>

<http://www.404manual.com>

<http://www.luxmanual.com>

<http://aubethermostatmanual.com>

Golf course search by state

<http://golfingnear.com>

Email search by domain

<http://emailbydomain.com>

Auto manuals search

<http://auto.somanuals.com>

TV manuals search

<http://tv.somanuals.com>