

OWNER'S MANUAL

LP Gas & Charcoal Grill



Duo Model #5050



A propane gas cylinder is required for operation. This gas grill is not intended for commercial use.

Keep your receipt with this manual for Warranty.

SAVE THESE INSTRUCTIONS FOR FUTURE REFERENCE. IF YOU ARE ASSEMBLING THIS UNIT FOR SOMEONE ELSE, GIVE THIS MANUAL TO HIM OR HER TO SAVE FOR FUTURE REFERENCE. FOR CUSTOMER SERVICE, CALL 912-638-4724

 **WARNING**
For Outdoor Use Only (outside any enclosure)

WARNING:
Improper installation, adjustment, alteration, service or maintenance could cause injury or property damage. Read the installation, operation and maintenance instructions thoroughly before assembling or servicing this equipment.

DANGER:
DO NOT use gas grill for indoor cooking or heating. TOXIC fumes can accumulate and cause asphyxiation. Do not use in or on boats or recreational vehicles.

PROP 65 WARNING:
Chemicals known to the state of California to cause cancer, birth defects or other reproductive harm are created by the combustion of propane.





If you smell gas:

1. Shut off gas to the appliance.
2. Extinguish any open flame.
3. Open Lid.
4. If odor continues, keep away from the appliance and immediately call your gas supplier or your fire department.



Do not store or use gasoline or other flammable liquids or vapors in the vicinity of this or any other appliance.

An LP cylinder not connected for use shall not be stored in the vicinity of this or any other appliance.

For Your Safety

Stop! Call us first! Do Not return product to store. This grill has been made to high quality standards. If you have any questions not addressed in this manual or if you need parts please call our customer service department at 1-912-638-4724 (USA), Monday-Friday 8:30 am-5 pm (EST).

Have your grills serial number (located on the back of the grill body or on the leg) when calling.

Table of Contents

Important Safety Information	page 4 - 5
Illustrated Parts List	page 6 - 7
Tools, Assembly Tips and Hardware List	page 8
Assembly Instructions	page 10 - 24

Operating Grill

Connecting Gas Cylinder.....	page 25
Checking for Leaks.....	page 26
Lighting Grill.....	page 27 - 29
Cleaning and Care.....	page 30 - 31
Trouble Shooting.....	page 32-33
Grill Preparation.....	page 34
Recipes.....	page 35 - 39
Accessories.....	page 40 - 41

WARNING

FOR YOUR SAFETY

1. DO NOT store or use gasoline or any other flammable vapors and liquids within 25 feet (8m) of this or any other appliance.
2. When cooking with oil/grease, do not allow the oil/grease to exceed 350 °F (177 °C). Do not store or use extra cooking oil in the vicinity of this or any other appliance.
3. An LP Cylinder not connected for use should be stored a minimum of 10 feet (3m) away from this or any other appliance. Never fill the cylinder beyond 80 percent full. If the above information not followed exactly, a fire causing death or serious injury may occur.
4. If you smell gas:
 - Shut Off gas to the grill.
 - Extinguish any open flame.
 - Open Lid

For Your Safety

Stop! Call us first! Do Not return product to store. This grill has been made to high quality standards. If you have any questions not addressed in this manual or if you need parts please call our customer service department at 1-912-638-4724 (USA), Monday-Friday 8:30 am-5 pm (EST).

NOTE: The use and installation of this product must conform to local codes. In absence of local codes, use the National Fuel Gas Code, ANSI Z223.1/NFPA54.

IMPORTANT NOTICE: read all instructions prior to assembly and use.

Read and understand all warnings and precautions prior to operating your grill.

CAUTION

1. This grill is for use with propane gas only (propane gas cylinder not included).
2. Never attempt to attach this grill to the self-contained propane system of a camper trailer, motor home or house.
3. Never use charcoal or lighter fluid with the gas grill.
4. Do not use gasoline, kerosene or alcohol for lighting. The LP-gas supply cylinder must be constructed and marked in accordance with the specifications for propane gas cylinders of the U.S. Department of Transportation (DOT) CFR 49. This grill is not intended to be used in or installed on recreation vehicles and/or boats.
5. Do not attempt to move the grill while it is lit.
6. Do not use the grill unless it is completely assembled and all parts are securely fastened and tightened.
7. Keep all combustible items and surfaces at least 36 inches (91.4cm) away from grill at all times.
8. DO NOT use this grill or any gas product near unprotected combustible constructions.
9. Do not use in an explosive atmosphere. Keep grill area clear and free from combustible materials, gasoline and other flammable vapors and liquids.

10. Do not touch metal parts of grill until it has completely cooled (about 45 minutes) to avoid burns, unless you are wearing protective gear (BBQ mittens, pot holders, etc.)
11. Do not alter this grill in any manner
12. Clean and inspect the hose before each use. If there is evidence of abrasion, wear, cuts, or leaks, the hose must be replaced prior to operating the appliance. The replacement hose assembly will be that which is specified by the manufacturer.
13. Move gas hoses as far away as possible from hot surfaces and dripping hot grease.
14. Never Keep a filled container in a hot car or car trunk. Heat will cause the gas pressure to increase, which may open the relief valve and allow gas to escape.
15. Keep the grill's valve compartment, burners and circulating air passages clean. Inspect the grill before each use.

WARNING

1. This grill is for outside use only, and should not be used in a building, garage or any other enclosed area.
2. The use of alcohol, prescription or non-prescription drugs may impair the operator's ability to properly assemble or safely operate the grill.
3. Always open grill lid slowly and carefully as heat and steam trapped within the grill can burn you severely.
4. Always place your grill on a hard, level surface far away from combustibles. An asphalt or blacktop surface may not be acceptable for this purpose.
5. Do not leave a lit grill unattended. Keep children and pets away from the grill at all times.
6. Do not place this grill on any type of tabletop surface.
7. Do not use the grill in high winds.
8. Disconnect the propane tank (LP tank) by first turning off valve on top of propane tank, turn off burner valves, then disconnect regulator from valve on propane tank by turning plastic connector counter clockwise. Unscrew wing-bolt in bottom shelf to release the tank for removal.

DANGER

Liquid propane (LP) gas is flammable and hazardous if handled improperly. Know its characteristics before using any propane product.

1. Propane Characteristics; Flammable, explosive under pressure, heavier than air and settles in pools and low areas
2. In its natural state, propane has no odor. For your safety, an odorant has been added.
3. Contact with propane can cause freeze burns to skin.
4. This grill is shipped from the factory for propane gas use only.
5. Never use a propane cylinder with a damaged body, valve, collar or footing.
6. Dented or rusted propane cylinders may be hazardous and should be checked by your propane gas supplier.

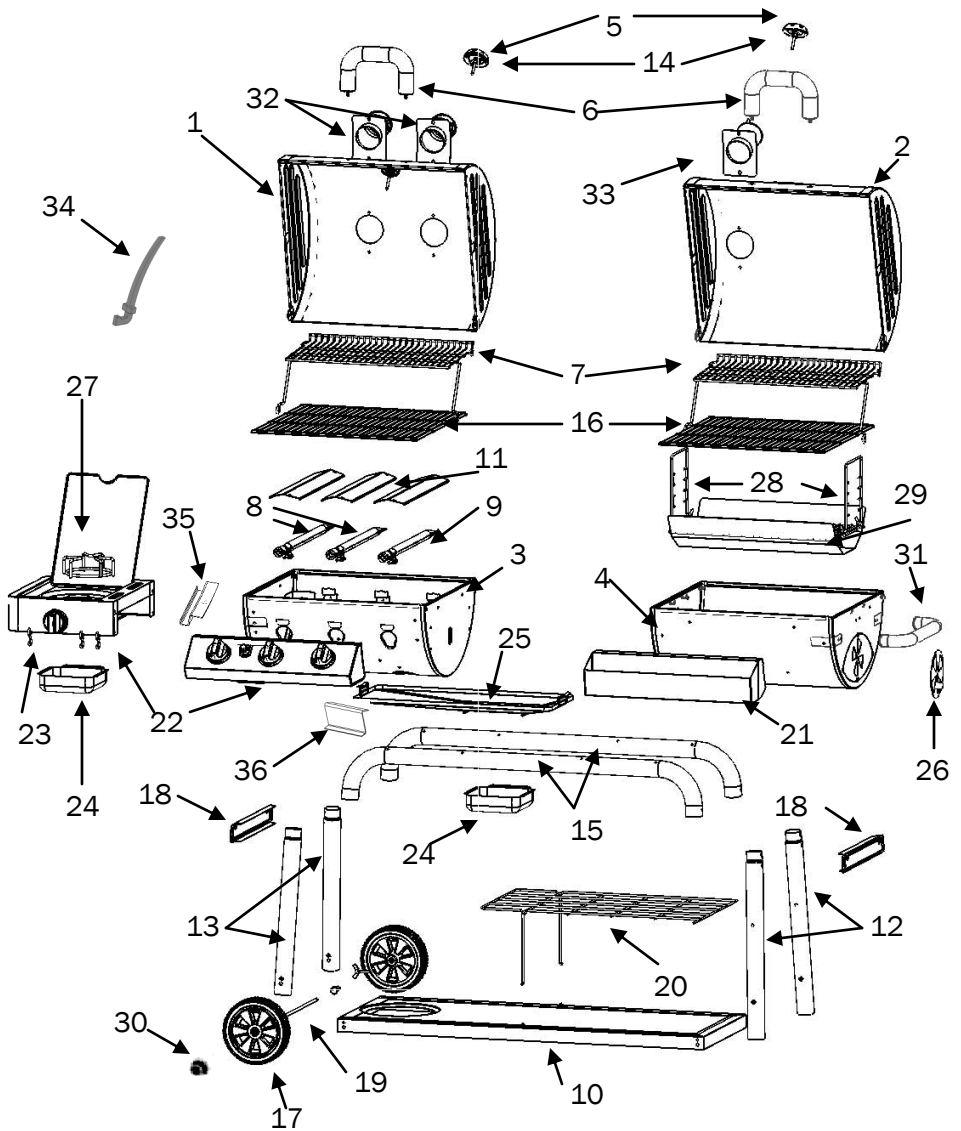

















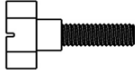

ITEM	QTY	PART NAME	PART NUMBER
1	1	GAS GRILL HOOD	30-0009
2	1	CHARCOAL GRILL HOOD	30-0013
3	1	GAS GRILL BODY	30-0010
4	1	CHARCOAL GRILL BODY	30-0014
5	2	THERMOMETER	55-0088
6	2	HOOD HANDLE	55-0009
7	2	WARMING RACK	20-0001
8	2	BURNER (short wire)	80-0007
9	1	BURNER (long wire)	80-0006
10	1	BASE	20-0037
11	3	FLARE-UP SHIELD	10-0001
12	2	LONG LEG	10-0031
13	2	SHORT LEG	10-0032
14	2	BEZEL	10-0358
15	2	LEG CROSS BAR	10-0033
16	6	COOKING GRATE	10-0325
17	2	WHEEL	55-0006
18	2	LEG BRACE	10-0034
19	1	AXLE	10-0327
20	1	WIRE SHELF	20-0038
21	1	CONDIMENT BASKET	20-0039
22	1	SIDE BURNER/ CONTROL PANEL	80-0009
23	3	UTENSIL HOOK	50-0002
24	2	GREASE TRAY	10-0028
25	1	CATCH PAN, REMOVABLE	20-0163
26	2	DAMPER CIRCLE	10-0036
27	1	POT STAND	20-0005
28	2	FIRE GRATE HANGERS, 8.5	20-0024
29	1	ASH PAN	20-0157
30	2	HUB CAP	55-0057
31	1	SIDE HANDLE	20-0040
32	2	GAS STACK	20-0034
33	1	CHARCOAL STACK	10-0184
34	1	GRATE LIFTER	10-0045
35	1	STOPPER BRACKET	10-0360
36	2	SLIDER BRACKET	10-0359

Assembly: Requires 2 people. Get another person to help. Tools Needed: Pliers, Phillips Head Screwdriver and a 7/16" Nut Driver.

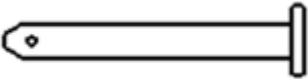
NOTE: Do Not tighten any bolts unless instructed to do so. Tightening too soon may prohibit parts from fitting together. All Hex Nuts should be on the inside of the grill unless stated otherwise. Unpack all contents in a well cleared and padded area. Estimated Assembly Time: 45 minutes STOP! Do Not Return to Store. If you are missing parts or need assistance please email us at info@chargriller.com or call 912-638-4724. Do not attempt assembly if you are missing parts.

Hardware: 550104

		1/4-20x 1 1/2" BOLT.....8 PCS
		1/4-20x 1/2" BOLT..... 41 PCS
		2/5" FLAT WASHER.....2 PCS
		1/4" FLAT WASHER.....10 PCS
		1/4-20 HEX NUT.....19 PCS
		1/4" LOCK WASHER.....35 PCS
		HINGE PINS.....2 PCS
		LARGE HAIR COTTER PIN.....2 PCS
		SMALL HAIR COTTER PIN.....3 PCS
		CENTER HINGE PIN.....1 PC
		SCREW.....3 PCS
		#10-24 x 0.40" BOLT.....6 PCS

Page intentionally left blank for notes

Step 1

Attach the LEFT LEGS & RIGHT LEGS to the BASE using four (4) ½" BOLTS and four (4) ¼" LOCK WASHERS as shown. When you install the LEFT LEG & RIGHT LEG, please make sure that the holes at the top of the LEGS are facing out. Please note that the wheel legs have inside and outside sides. The axel will not fit through the legs if the outside of the leg is not facing out

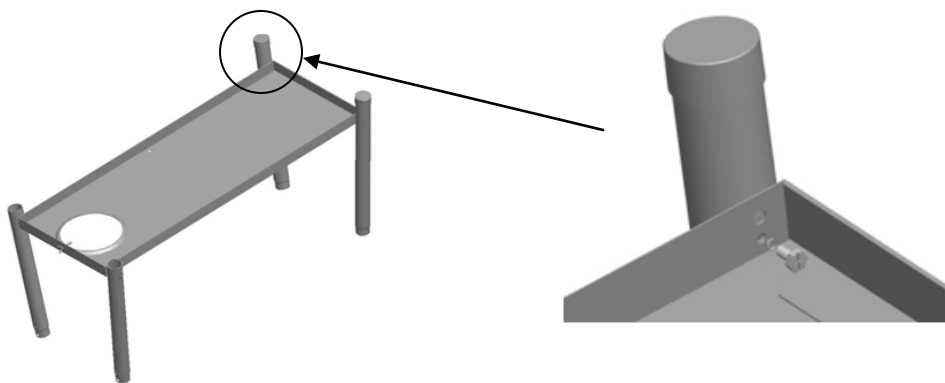

Step 2

Attach the LEG CROSSBAR to the frame as shown making sure that the holes on the CROSSBAR are facing inward. See below.

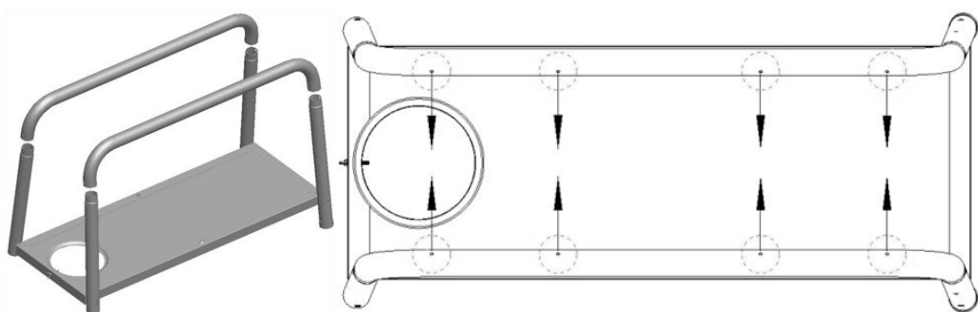

Step 3

Attach BOTTOM SHELF to the LEGS (as shown below).

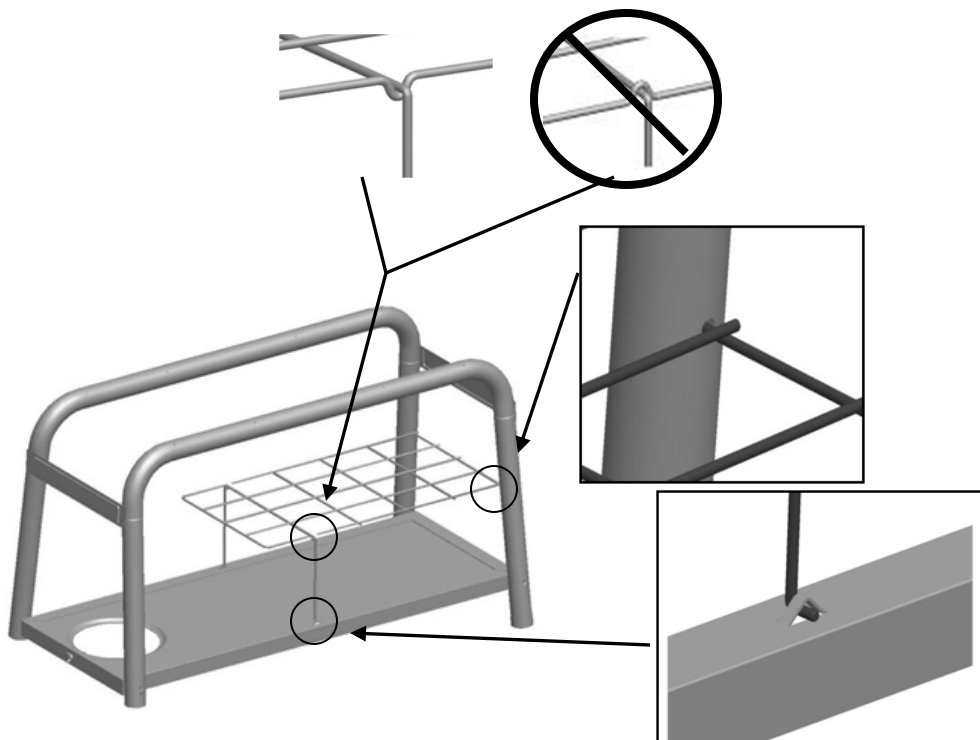

Step 4

Install the LEG BRACES to the LEGS using eight (8) LOCK WASHERS and eight (8) 1/2" BOLTS as shown. Remember to NOT tighten the bolts until completing step 6.

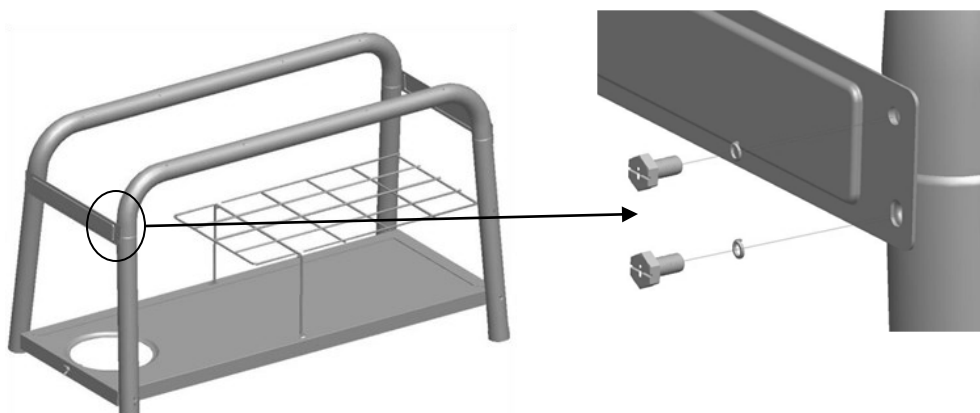

Step 5

Install one WASHER, COTTER PIN and HUB CAP onto the AXLE then slide the AXLE through WHEELS and legs as shown. Finish by attaching 2nd WASHER, COTTER PIN and HUB CAP.

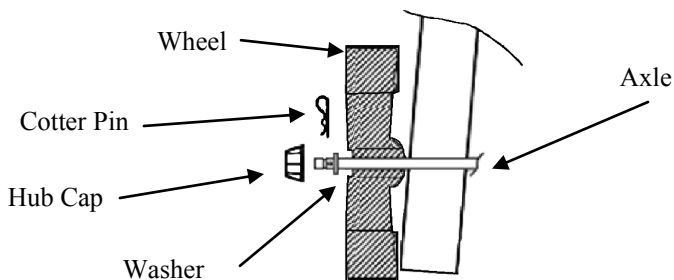

Step 6

Attach the GAS GRILL BODY and CHARCOAL GRILL BODY to the LEG CROSSBAR using eight (8) ½" BOLTS, eight (8) LOCK WASHERS and eight (8) FLAT WASHERS in order shown. Make sure to insert the bolt first through the lock washer then the flat washer then through the grill body as shown.

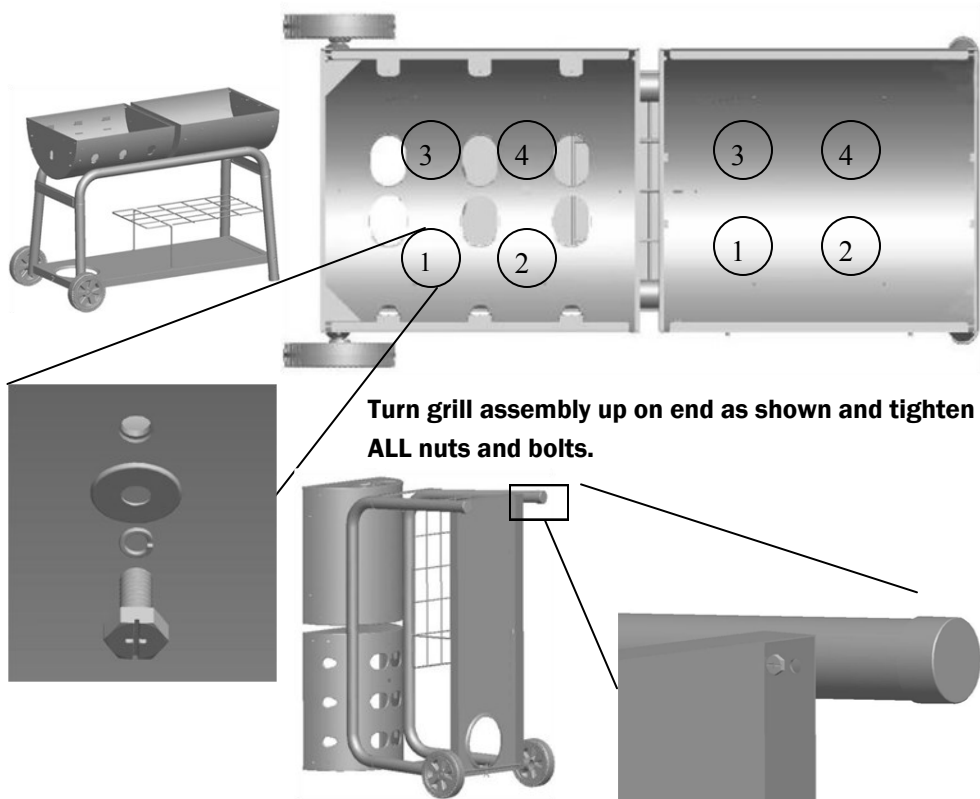

Step 7

Attach (2) SLIDER BRACKETS and (1) STOPPER BRACKET to Bottom of GRILL BODY as shown on Figure 2 and Figure 3 using (6) #10-24 x 0.40" bolts. NOTE: Oriented Brackets as shown in Figure 1. Install CATCH PAN by placing CATCH PAN support brackets on top of SLIDER BRACKETS underneath GRILL BODY, see Figure 4, and then slide it forward until you can hang the CATCH PAN side bracket onto the STOPPER BRACKET. From the rear of the grill, slide the GREASE TRAY into the guides/ rails under the CATCH PAN.

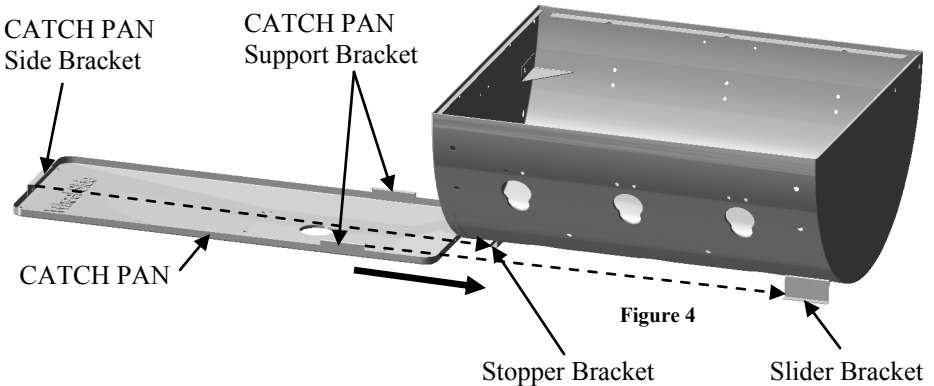
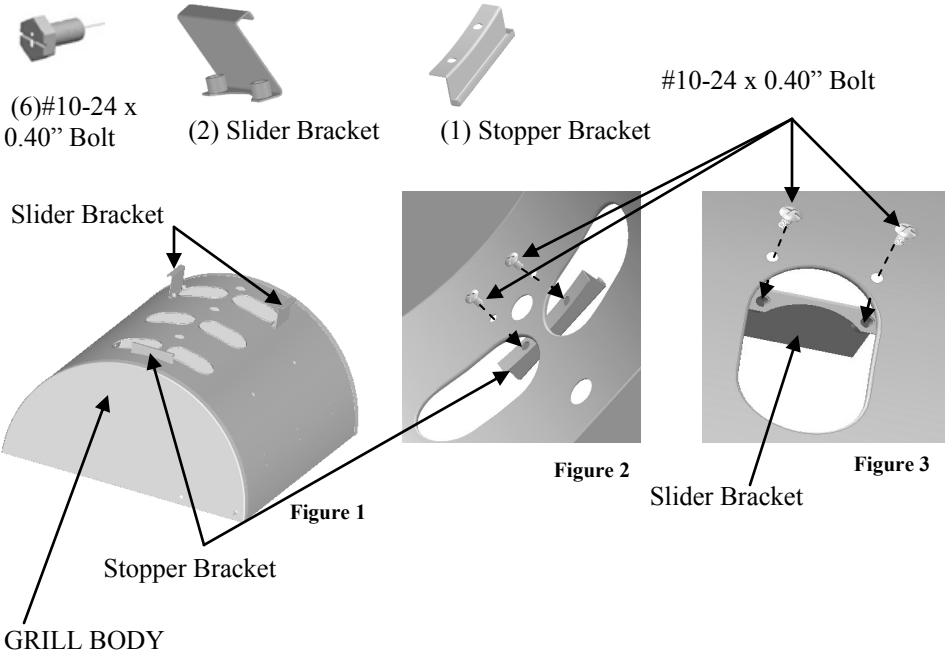

Step 8

Install the SIDE BURNER and the CONTROL PANEL to the GRILL BODY with eight (8) $\frac{1}{2}$ " BOLTS and eight (8) LOCK WASHERS. Make sure the SIDE BURNER VALVE tip is completely inside of the SIDE BURNER VENTURI TUBE see figure below. (NOTE: Hose should be on the outside of the leg brace). Then tighten all the bolts. Slide GREASE TRAY onto the rail underneath CATCH PAN. Slide the other GREASE TRAY onto the rail underneath the SIDE BURNER PAN.

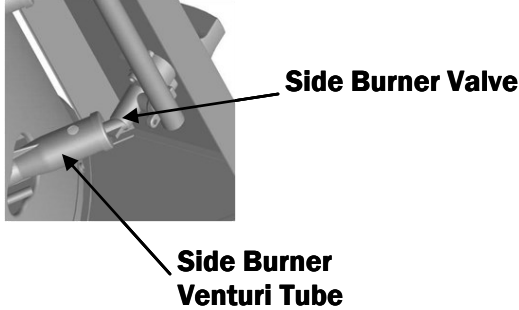
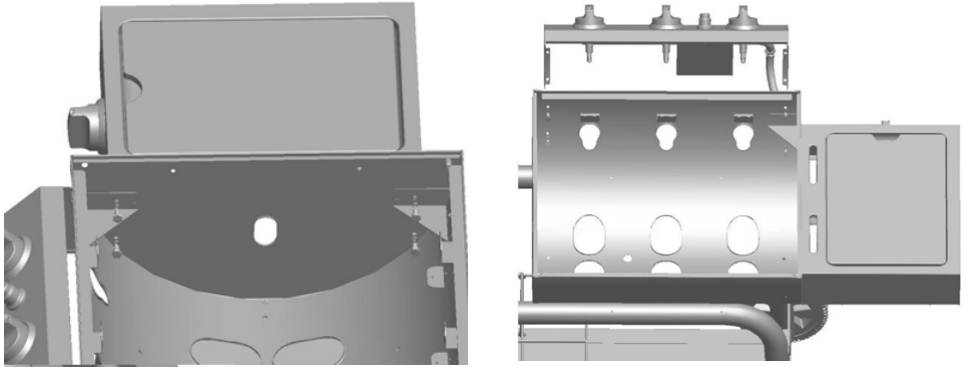

Side Burner Valve

Side Burner Venturi Tube

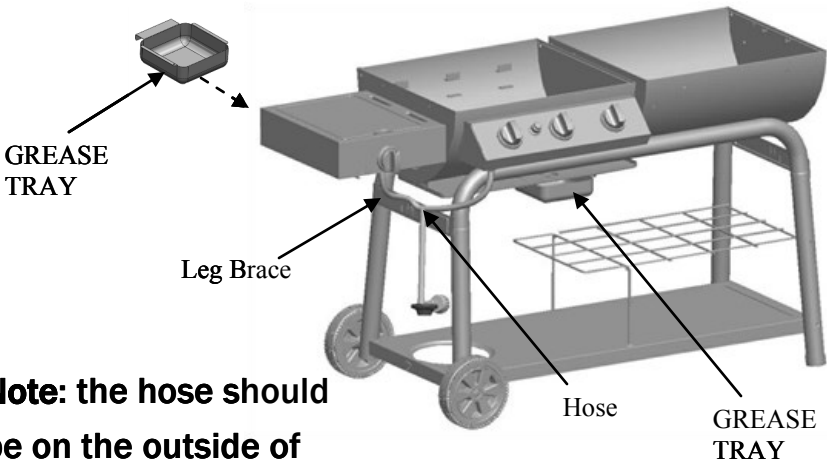

GREASE TRAY

Leg Brace

Hose

GREASE TRAY

Note: the hose should be on the outside of the leg brace.

Step 9

Install the MAIN BURNERS into the GRILL BODY by first inserting the open end of the BURNERS through the holes in the front of the grill body. Making sure the VALVE tips are inside the burner tubes. The BURNER with the longest wire is installed on the right side of the GAS GRILL BODY. Secure the BURNER to the GAS GRILL BODY with the SCREWS provided.

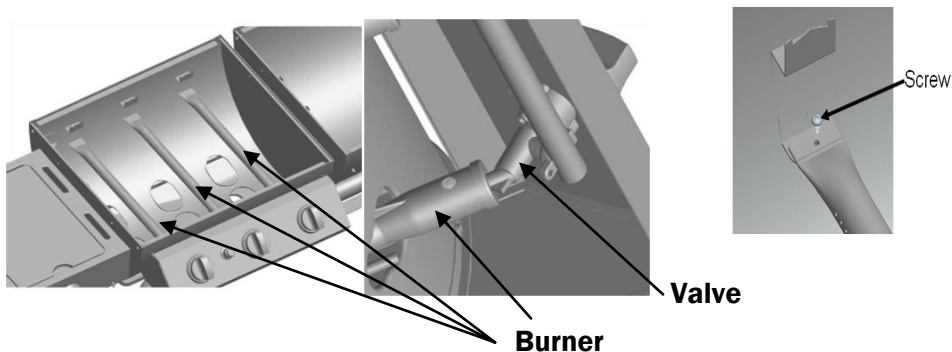

Step 10

Insert the IGNITER WIRES, which are attached to the underside of each BURNER, through the same hole in the GRILL BODY that the BURNER goes through and then attach the WIRE to the backside of the ELECTRONIC IGNITER, which is attached to the back side of the CONTROL PANEL. Any wire can go into any of the three sockets on the Electronic Igniter.

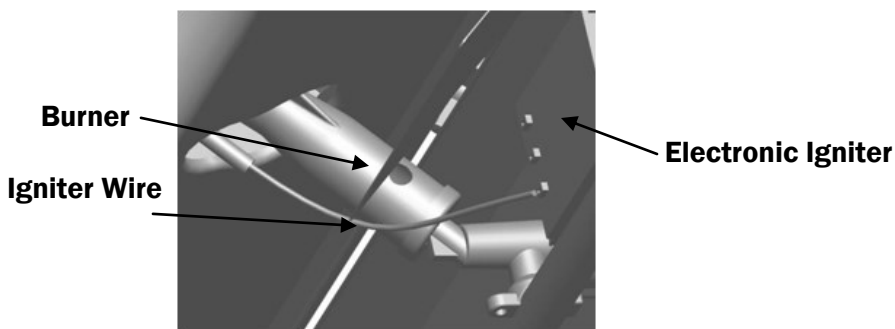

Step 11

Install the CONDIMENT BASKET to the CHARCOAL GRILL BODY using four (4) LOCK WASHERS and four (4) ½" BOLTS. From inside the GRILL BODY the BOLTS go through a LOCK WASHER and then through the GRILL BODY and then screw into the CONDIMENT BASKET.

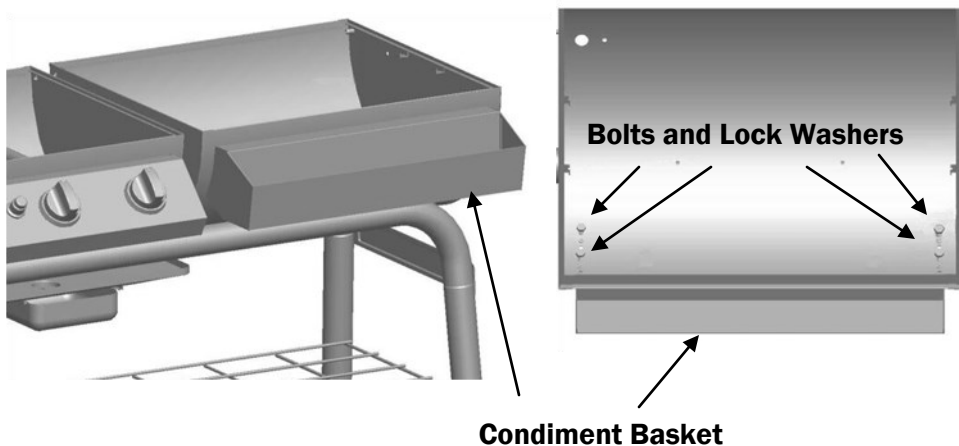

Step 12

Install the SIDE DAMPER to the CHARCOAL GRILL BODY using one (1) ½" BOLT. The BOLT should first go through a FLAT WASHER then the DAMPER then the GRILL BODY then another FLAT WASHER then a LOCK WASHER and then secured with a HEX NUT. See below.

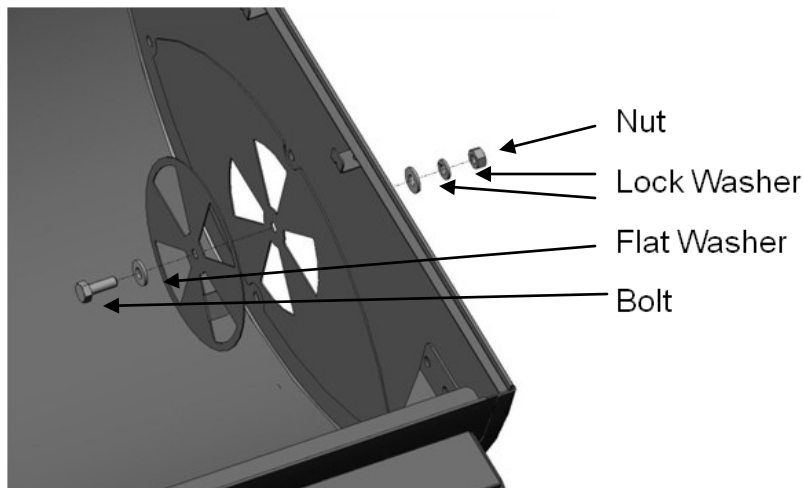

Step 13

Attach the SIDE HANDLE to the right side of the CHARCOAL GRILL BODY using two (2) ½" BOLTS and two (2) LOCK WASHERS as shown. From inside the GRILL BODY insert each BOLT through a LOCK WASHER and then through the GRILL BODY and then screw into the SIDE HANDLE. See below.

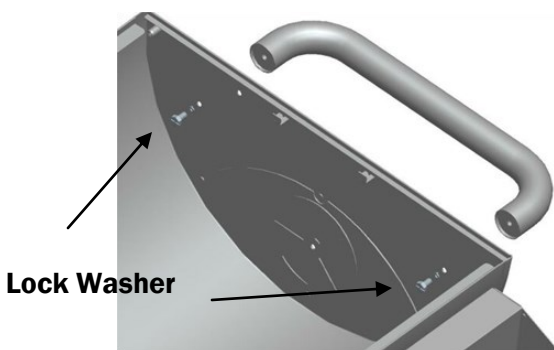

Step 14

Attach the HOOD HANDLES to the GRILL HOODS with four (4) LOCK WASHERS and four (4) WING NUTS as shown below.

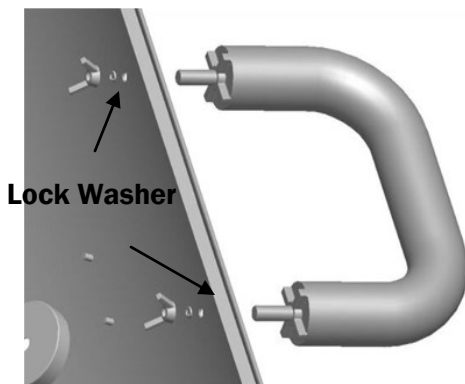

Step 15

Install the GAS CHIMNEY to the GAS GRILL HOOD and the CHARCOAL CHIMNEY to the CHARCOAL GRILL HOOD. Insert the CHIMNEYS through each hole from inside the HOOD and secure with two (2) HEX NUTS and two (2) ½" BOLTS for each CHIMNEY, see below.

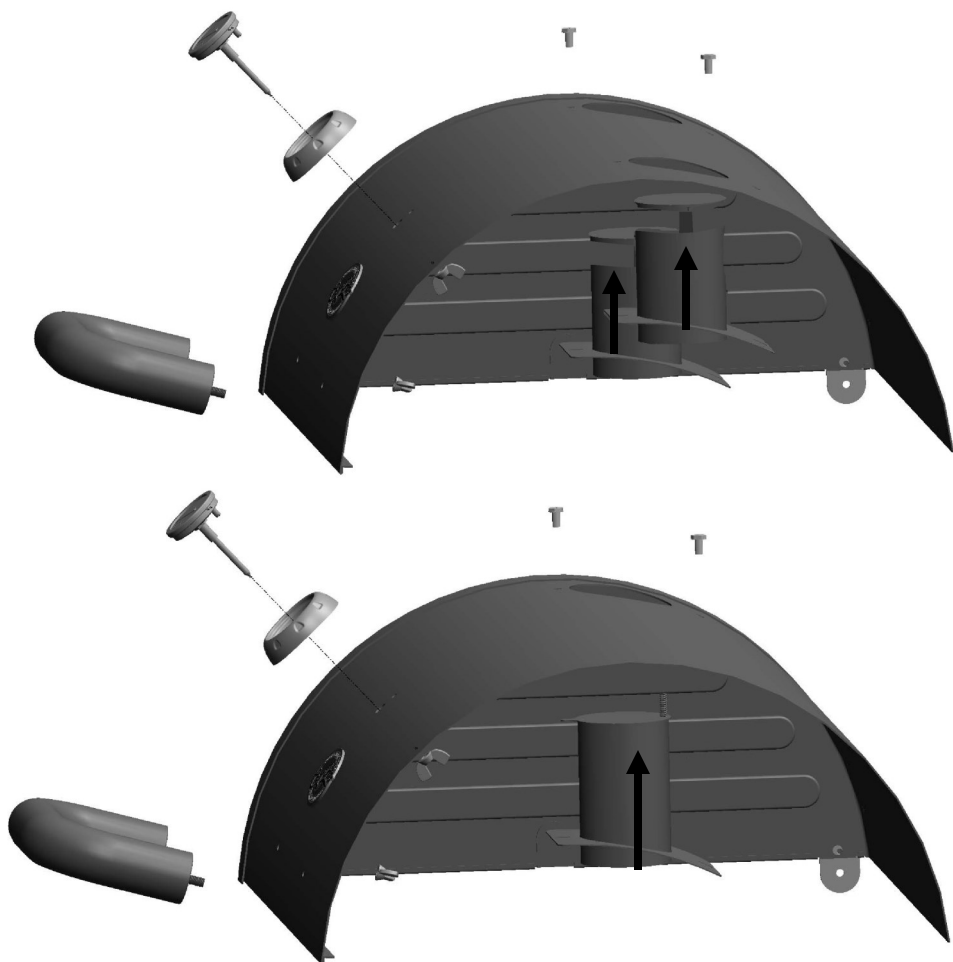

Step 16

Insert the THERMOMETERS through BEZEL into the GRILL HOODS and secure with two (2) WING NUTS as shown.

Step 17

Attach HOODS to the GRILL BODIES using HINGE PINS as shown. Have your helper stand behind the grill to hold the HOODS in place and keep them from falling. First place the GAS HOOD onto the GRILL BODY in the closed position then screw the left HINGE PIN into place. Then place the Charcoal HOOD in place and screw in the right HINGE PIN. Carefully and slightly open the Charcoal HOOD and insert the center HINGE PIN from inside the charcoal grill through the HOOD then through the Gas HOOD and Body as shown. Then insert COTTER PINS through the holes in the three HINGE PINS.

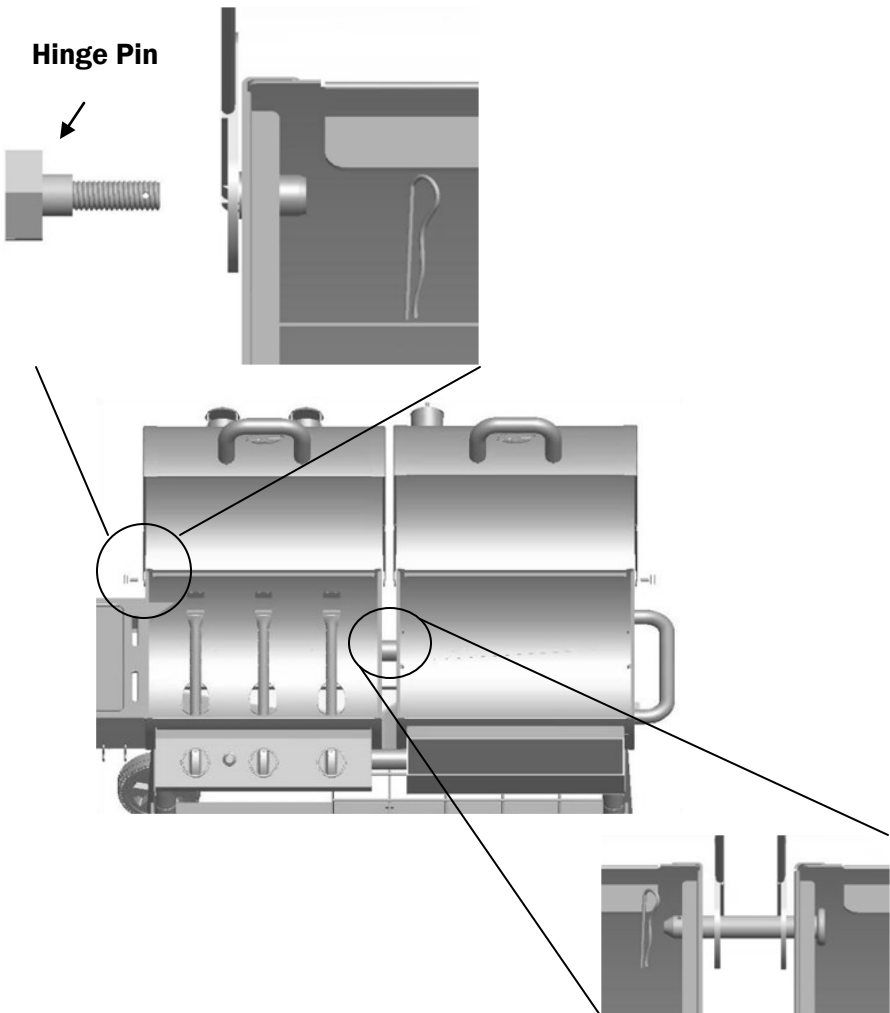

Step 18

Before attaching WARMING RACKS you must attach the warming rack pivot BOLTS to the GRILL HOOD and BODY. Insert the 1 1/2" BOLTS through the holes in the sides of the HOODS from the outside and tighten the HEX NUTS on the inside of the HOODS. Insert the 1 1/2" BOLTS through the holes in the sides of the GRILL BODIES from the outside and tighten the HEX NUTS on the inside of the GRILL BODIES. Now, you can attach the warming racks to these bolts as shown below and secure with HEX NUTS only finger tight.

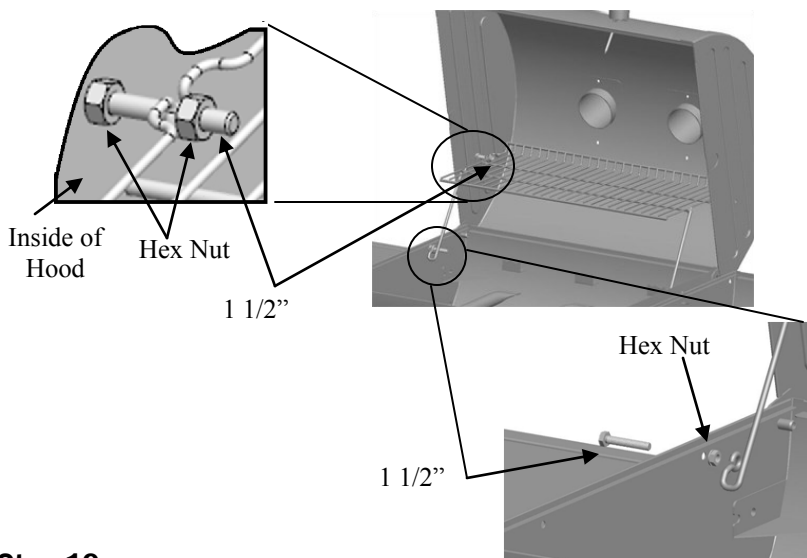

Step 19

Set the POT STAND in place over the SIDE BURNER. Next install the three (3) FLARE-UP SHIELDS over the BURNER TUBES then hang the FIRE GRATE/ ASH PAN from the FIRE GRATE HANGERS on the catch tabs that are welded to the inside of the CHAR-COAL GRILL BODY sides.

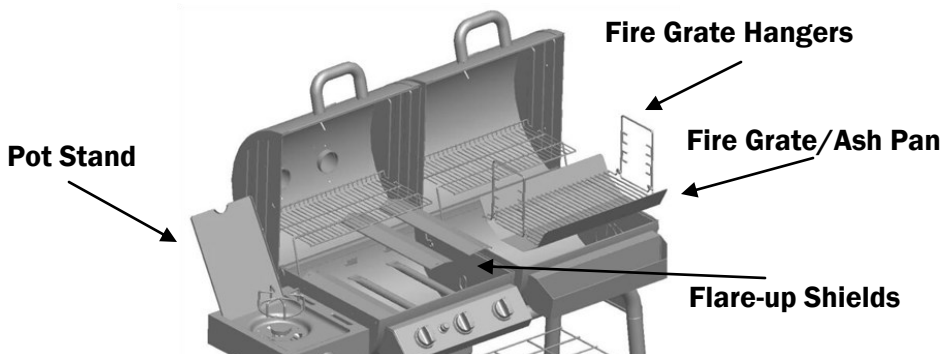

Step 20

Install the COOKING GRATES.

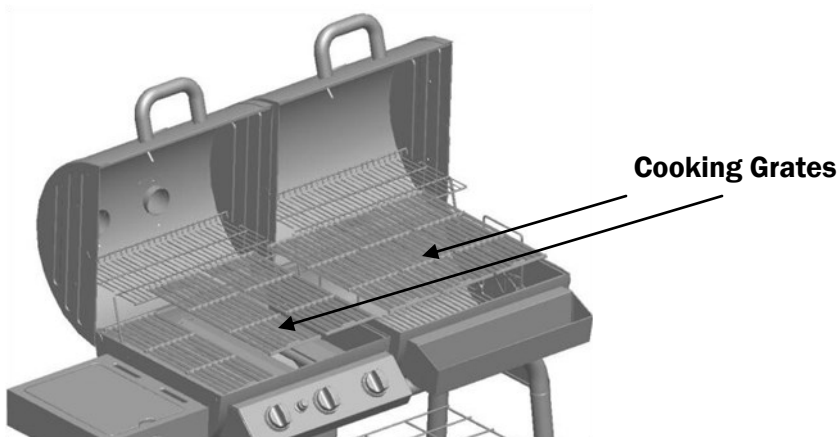

Step 21

Slide the GREASE TRAY into place on the guide rails under the Side Burner as shown below. Insure that the GREASE TRAY is centered under the burner.

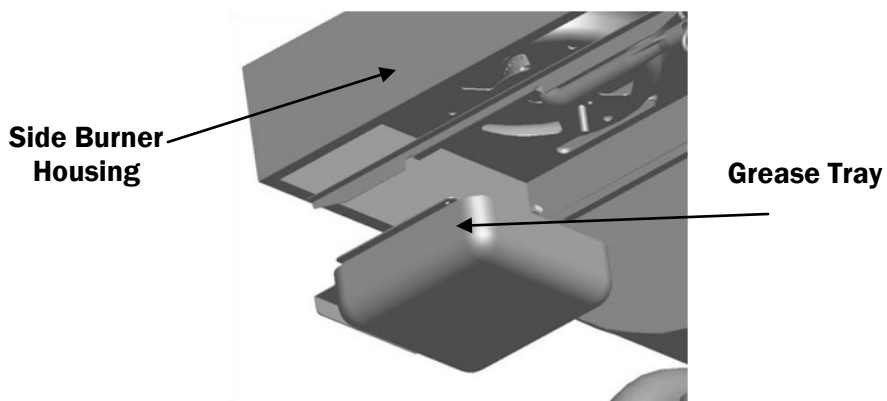

Step 22

1. Place a standard 20 lb. Type 1 LP gas cylinder (see below, not included) into the cart assembly and connect the cylinder with the gas hose/regulator as shown. (See page 19 for further instructions).
2. Turn the Screw on the left side of the base panel clockwise to secure the standard 20 lb. LP gas cylinder.

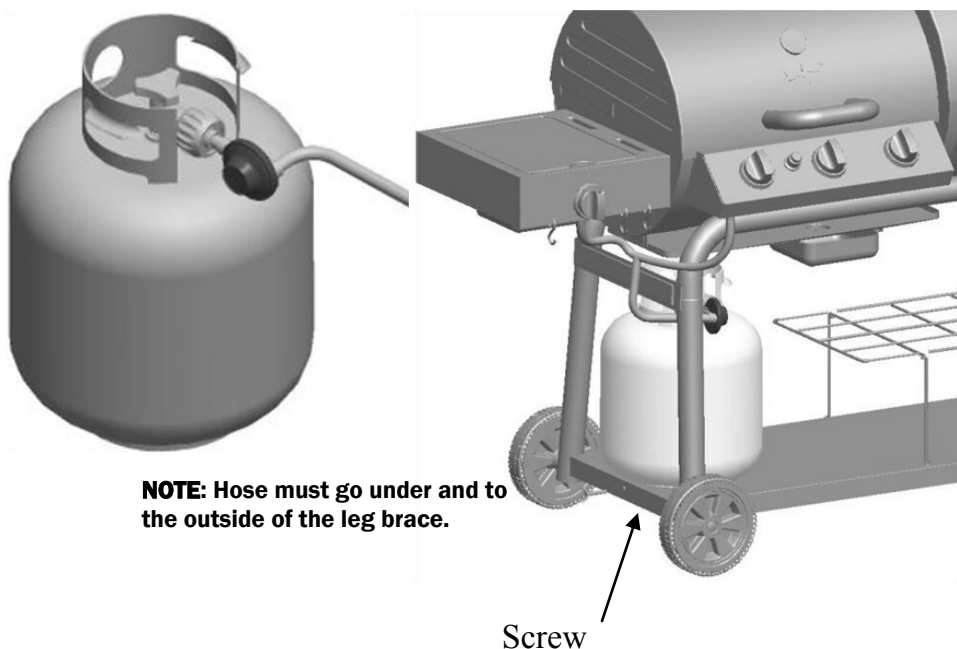

Purging using a type 1 connection:

L.P. Gas cylinder evacuation can be accomplished during each purging by using a Type 1 connection. The Type 1 valve outlet has an external 1 5/16" ACME right hand thread which will accept this connection.

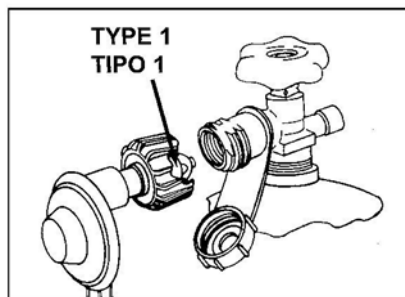

Step 23

Install Igniter battery by turning the Igniter push button cap counter-clockwise until the igniter button detaches, then install a AA battery making sure the positive(+) end is under the push button. Then re-attach the igniter button by turning it clockwise. Press the igniter button and make sure all 3 igniters that are attached to the burner tubes are creating a spark.

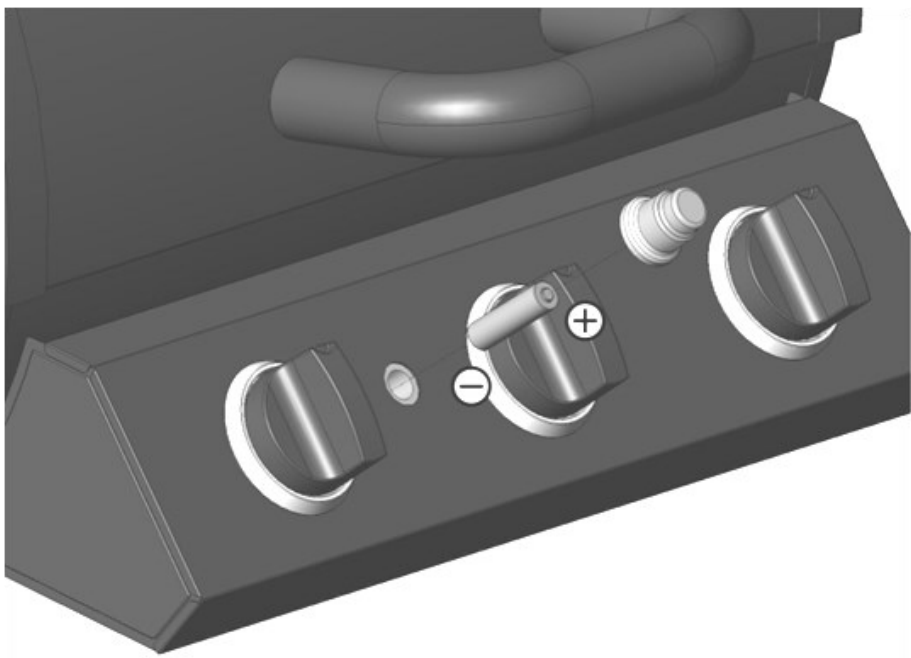

Step 24

Tighten ALL BOLTS and NUTS.

Fully Assembled



Caution: Use only the regulator provided!

If a replacement is necessary, please call our customer service department, 912-638-4724. Do NOT use replacement parts that are not intended for this grill.

Hint: The paper label that is affixed to the hood is more easily removed when the hood is warm. Any remaining glue residue can be cleaned off with a spray lubricant like WD-40. Do NOT use any other type of solvent or cleaner because this will damage the finish/paint/coating on the grill.

Connecting Gas Cylinder:

The propane gas supply cylinder to be used must be constructed and marked in accordance with the Specifications for propane gas Cylinders of the U.S. Department of Transportation (DOT), or the National Standard of Canada, CAN/CSA B339, Cylinders, Spheres and Tubes for Transportation of Dangerous Goods; and Commission, as applicable. Only cylinders with a listed overfill prevention device (OPD) and marked “propane” may be used. Cylinders with an OPD will have valve handles with three “lobes” (prongs). Only use 20-pound cylinders equipped with a Type 1 cylinder connection device for outdoor cooking appliances. The cylinder must include a collar to protect the cylinder valve. The gas cylinder should not be dropped or handled roughly! If the appliance is not in use, the gas cylinder must be disconnected. Storage of an appliance indoors is permissible ONLY if the cylinder is disconnected and removed from the appliance. Cylinders must be stored outdoors out of the reach of children and must not be stored in a building, garage or any other enclosed area. Your cylinder must never be stored where temperatures can reach over 125 F. Before connection, be sure that there is no debris caught in the head of the gas cylinder, head of the regulator valve or in the head of the burner and burner ports. Connect regulator valve and hand-tighten firmly. Disconnect the propane cylinder from the regulator valve when the grill is not in use. DO NOT obstruct the flow of combustion air and ventilation air to the grill. The propane cylinder must be arranged for vapor withdrawal and equipped with a listed overfilling prevention device. For proper vapor withdrawal, the cylinder should be used in the proper upright position (refer to illustration under step 22 of page 17).

DANGER

Never store a spare propane cylinder near this grill.

A fire causing death or serious injury may occur if the above is not followed exactly.





Stand in front of the grill to operate the controls.

Note: Before starting the grill, check for leaks. Make sure the regulator valve is securely fastened to the burner and the cylinder.

To prevent fire or explosion hazard when testing for a leak:

1. Always perform the “leak test” as described below before lighting the grill or each time the cylinder is connected for use.
2. Do not smoke or allow other sources of ignition in the area while conducting a leak test.
3. Conduct leak test outdoors in a well-ventilated area.
4. Do not use matches, lighters or a flame to check for leaks.
5. Do not use grill until any and all leaks are corrected. If you are unable to stop a leak, disconnect the propane supply. Call a gas appliance serviceman or your local propane gas supplier.

To Perform a Leak Test:

Make a 2-3 oz (0-90ml.) of leak solution by mixing one part liquid dishwashing soap with three parts water in a spray bottle.

Note: Make sure control knobs are off.

Spray solution on the tank valve to regulator connection, the “Y” joint in the hose, the connection to the manifold behind the main control panel, and the connection to the side burner valve.

Inspect the solution at the connection looking for bubbles. If NO bubbles appear, the connection is secure. If bubbles appear, you have a leak.

Check the regulator connection as follows:

Disconnect regulator from the tank and reconnect, making sure the connection is secure. Retest with solution. If you continue to see bubbles, replace the cylinder.

Lighting Your Grill

Danger: Failure to open hood while igniting the grill or not waiting 5 minutes to allow the gas to clear if the grill does not light, may result in an explosive flare-up which can cause serious bodily injury or death.

Before cooking on this grill for the first time, operate the grill for about 15 minutes with the lid closed and the gas turned on “high”. This will “heat clean” the internal parts and dissipate odor from the manufacturing processes and painted finish.

Main Burners:

1. Always open the lid before lighting the grill.

Attempting to light the burner with the lid closed may cause an explosion!

2. Make sure there are no obstructions of airflow to the gas unit. Spiders and insects can nest within and clog the burner/venturi tube at the orifice. A clogged burner tube can lead to a fire beneath the appliance.
3. Make sure all burner knobs are in the OFF position.
4. Open the valve on the LP gas cylinder.
5. Ignite only the burners you desire to use, using the same method for each: Push in desired burner knob fully and rotate slowly about $\frac{1}{4}$ turn counter-clockwise to “HIGH”. **If the burner does not light immediately**, return the knob to OFF, wait **Five minutes** for the gas to clear and repeat the procedure. After the burner ignites, repeat the same procedure with any other burner desired. Adjust knobs to desired cooking setting.

After lighting, observe the burner flame, make sure all burner ports are lit.

If burner flame goes out during operation, immediately turn the gas “off” at the control panel and at the gas cylinder and open hood/lid to let the gas clear for about 5 minutes before re-lighting. **Clean your grill after each use**, DO NOT use abrasive or flammable cleaners, as it will damage the parts of this product and may start a fire.



Side Burner

1. Open lid during lighting. Lid must be open when burner is on.
2. Burner valves must be in the “off” position.
3. Open cylinder valve.
4. Push in side burner valve knob fully and rotate slowly about $\frac{1}{4}$ turn counter-clockwise

until a click is heard. **If the burner does not light**, immediately turn the valve knob to OFF. **Wait 5 minutes** for the gas to clear and repeat the procedure.

After burner ignites, adjust valve knob to desired cooking setting.

Shutting Off Burners:

1. Always turn the valve knob(s) clockwise to the HI position, then push in and turn to OFF. Never force the knob without depressing it as this can damage the valve.
2. Promptly turn the gas supply OFF at the propane cylinder.
3. Close the lid of the grill.

Observe Flame Height When Lit:

Flame should be a Blue / Yellow color.

To visually check that the burner is operating, look at the burner flame through the flame viewing hole. The flame should be approximately $\frac{1}{2}$ - $\frac{3}{4}$ inch long with the high setting.



Lighting Burner With a Match:

1. Place a match in the end of the match holder that is installed on the side of Grill Housing. Once lit, immediately place the flame through the cooking grates as shown near the burner ports.
2. Press in knob and rotate counter-clockwise to the High setting and burner should light immediately.
3. Adjust burners to desired cooking settings

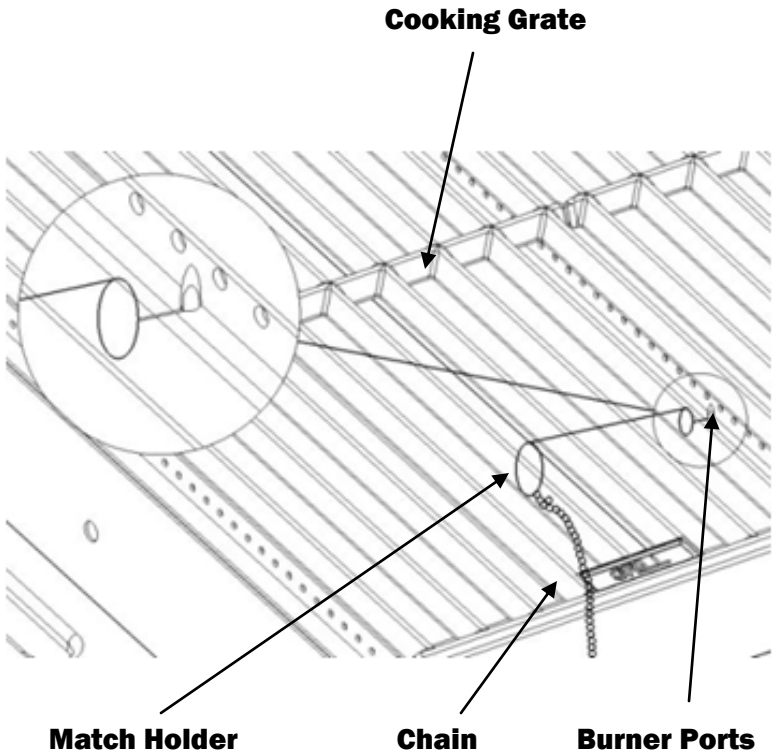

Cleaning and Care

Caution:

All cleaning and maintenance should be done when grill is cool and with the gas supply turned off at the propane cylinder.

DO NOT clean any grill part in a self cleaning oven. The extreme heat will damage the finish.

Cleaning

Burning-off the grill after every use (approx. 15 minutes) will keep excessive food residue from building up.

Recommended cleaning materials:

- Mild dishwashing liquid detergent
- Hot water
- Nylon cleaning pad
- Wire brush

DO NOT use cleaners that contain acid, mineral spirits or xylene.

Outside surfaces –

Use a mild dishwashing detergent and hot water solution to clean, then rinse with water.

If the inside surface of the grill lid has the appearance of peeling paint, baked on grease buildup has turned to carbon and is flaking off. Clean thoroughly with strong solution of detergent and hot water.

Rinse with water and allow to completely dry.

Interior of grill bottom – Remove residue using brush, scraper and/or cleaning pad, then wash with dishwashing detergent and hot water solution. Rinse with water and let thoroughly dry.

Cooking Grids – The porcelain grates have a glass-like composition that should be handled with care not to chip. Use mild dishwashing detergent or baking soda and hot water solution. Non abrasive scouring powder can be used on stubborn stains, then rinse with water.

Heat Shield – Clean residue with wire brush and wash with soapy water. Then rinse with water.

Cleaning the Burner Assembly

- Remove grease collector.
- Remove cooking grates and heat shield.
- Remove burner by unscrewing nut from beneath burner “foot” using a screwdriver and pliers.
- Lift burner up and away from gas valve orifice.
- Clean inlet (venturi) of burner with small bottle brush or compressed air.
- Remove all food residue and dirt on outside of burner surface.
- Clean any clogged ports with a stiff wire (such as an opened paper clip)
- Inspect burner for any damage (cracks or holes). If damage is found, replace with new burner. Reinstall burner; check to insure that gas valve orifices are correctly positioned inside burner inlet (venturi). Also check position of spark electrode.

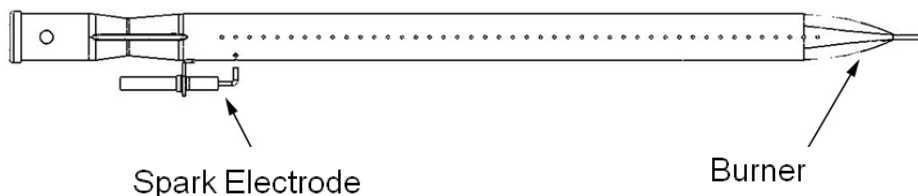

Gas Grill Trouble Shooting

Problem	Possible Cause	Prevention/Cure
Burner will not light using knobs	Wires/or electrode covered with cooking residue.	Clean wire and/or electrode, with rubbing alcohol
	Electrode and burners are wet.	Wipe dry with cloth
	Electrode cracked or broken -sparks at crack	Replace electrode
Burner will not light with match.	Wire loose or disconnected	Reconnect wire or replace electrode/wire assembly.
	No gas flow.	Check if propane tank is empty. If propane tank is not empty. Refer to "Sudden drop in gas flow or reduced flame height". If empty, replace or refill.
	Coupling nut and regulator not connected.	Turn the coupling nut about one-half full connected to three quarters additional turn until solid stop. Tighten by hand only -do not use tools.
	Obstruction of gas Flow.	Clear burner tubes. Check for bent or kinked hose.
	Disengagement of burner to valve.	Re-engage burner and valve.
	Insect nests in venturi (burner insert).	Clean venturi.
Sudden drop in gas flow or reduced flame height.	Burner ports clogged or blocked.	Clean burner ports.
	Out of gas	Change Propane Tank
Irregular flame pattern, flame does not run the full length of burner.	Excess flow safety device may have been activated.	Turn off knobs, wait 30 seconds and light grill. If flames are still too low. Reset the excessive flow safety device by turning off knobs and propane tank valve. Disconnect regulator. Turn burner control knobs off. Reconnect regulator and leak check connections. Turn propane tank valve on slowly, wait 30 seconds and then light the grill.
	Burner ports are clogged or blocked.	Clean Burner ports

Gas Grill Troubleshooting, continued

Problem	Possible Cause	Prevention/Cure
Flame is yellow or orange.	New burner may have residual Manufacturing oils.	Burn Grill for 15 minutes with the lid closed.
	Insect nests in venturi.	Clean venturi.
	Food residue, grease or seasoning salt on burner.	Clean burner.
	Poor alignment of valve to burner venturi.	Assure burner venturi is properly engaged with valve.
Flame blows out	High or gusting winds	Turn front of grill to face wind or increase flame height. (We recommend not using grill during high winds)
	Low gas pressure	Change Propane Tank
	Excess flow valve tripped	Refer to "Sudden drop in gas flow or reduced flame height"
Flare-Up	Grease buildup	Clean Grill
	Excessive fat in meat	Trim fat before grilling
	Excessive cooking Temperature	Adjust (lower) temperature accordingly
Persistent grease fire	Grease trapped by food buildup around burner system.	Turn knobs to OFF. Turn gas off.
Flashback (fire in burner tube(s))	Burner and/or burner tubes dirty.	Clean burner and/or burner tubes.
Inside of lid appears to be peeling - like paint peeling	Baked on grease buildup has turned to carbon and is flaking off.	Clean inside of lid thoroughly. The lid is not painted on the inside

GRILL PREPARATION & CHARCOAL GRILL OPERATING INSTRUCTIONS

PLEASE NOTE: NO RETURNS ON USED GRILLS

Read all safety warnings and instructions carefully before assembling and operating your grill.

1. Note: The interior of the grills are not painted, they are coated with vegetable oil. DO NOT remove this coating. Gas and Charcoal Grill: Cure grills prior to cooking to protect the interior and exterior finishes and prevent adding unnatural flavors to your food. (A) Lightly coat ALL INTERIOR SURFACES (including INSIDE OF BARREL, AND COOKING GRATES) with additional vegetable oil (spray vegetable oil is easiest but KEEP AWAY FROM HOT COALS, FIRE OR FLAME). (B) Charcoal Grill: Build a medium sized fire on the fire grate. (C) Charcoal Grill: After coals turn grey, spread out coals and replace cooking grates. (D) Gas Grill: Light burners and set on Medium-Low heat. (E) Gas and Charcoal Grills: Close lid and maintain heat at approximately 250° F (120° C) for two hours. You can lightly coat the exterior of both GRILL bodies (while warm) with vegetable oil and wipe off excess with a rag. This will extend the life of the finish, much like waxing a car. Your GRILLS will then be ready for use. Note: Oil will drip from the GRILL for several uses, but will slow over time.

NEVER EXCEED 450° F (230° C) BECAUSE THIS WILL DAMAGE THE FINISH AND CONTRIBUTE TO RUST. PAINT IS NOT WARRANTED AND WILL REQUIRE TOUCH-UP. THIS UNIT IS NOT WARRANTED AGAINST RUST. EXCEEDING 450° F WILL ALSO DAMAGE THE PORCELAIN FINISH ON THE COOKING GRATES.

2. Charcoal Grill: To START FIRE –stack 50-60 briquettes in pyramid and saturate with lighter fluid (DON'T USE GASOLINE). Light coals in several places, close lid after briquettes ash over or gray, spread them out and start cooking. If one end burns faster, use tongs to move coals from one end to the other for even heat. ALWAYS FOLLOW CHARCOAL AND LIGHTER FLUID MANUFACTURERS' INSTRUCTIONS AND WARNINGS. USE OUTDOORS ONLY ON NONCOMBUSTIBLE SURFACE – 15' AWAY FROM WOOD AND COMBUSTIBLE MATERIAL.

3. Charcoal Grill: Control heat with amount and type of FUEL, DUAL DAMPERS and ADJUSTABLE FIRE GRATE. Adjust GRATE one end at a time. Wood burns hotter than coals. More airflow is more heat.

4. For less flare-ups, cook with lid in the down position.

5. Charcoal Grill: Add water soaked hardwood chips for a smoked flavor.

6. Charcoal Grill: Burn out may be rust out. Ashes left in bottom too long hold moisture and rust through any thickness of steel.

7. This grill is made of steel and cast iron, which **WILL RUST, ESPECIALLY IF NOT PROPERLY CARED FOR.**

8. Charcoal Grill: Do not use self-starting charcoal as it will give unnatural flavor. Burn lighter fluid completely before closing lid.

9. After using, coat vegetable oil on bare metal while warm to reduce rust. On the EXTERIOR, remove rust with wire brush and touch up with a high heat paint, available at most hardware/auto stores.

10. Make sure to empty Grease Tray after every use only after it has completely cooled.

11. HEAT GAUGES may obtain moisture, which will steam out during cooking. Gauge may be calibrated in oven.

12. You may fill unwanted holes with Nuts & Bolts (Not Provided).

NOTE: Smoke will escape from areas other than the smokestacks. This will not affect your cooking

GRILLING RECIPES

DIRECT METHOD

STEAK (& ALL MEATS): Cook food directly above coals/heat. Generally speaking, to grill meats, raise fire grate to high position (hot) and sear for one minute on each side with the lid open to seal in flavor and juices. Then lower fire grate to medium position with lid closed and cook to desire doneness.

Control heat with dual dampers and adjustable fire grate.

BETTER BARBECUE: Place grilled meat back in the marinade for several minutes before serving – it will become tastier and juicier. CAUTION: Boil extra marinade first to kill bacteria remaining from the raw meat.

Tip: Cooking with a MEAT THERMOMETER ensures food is fully cooked. Insert into thickest part not touching bone & allow five minutes to register. Internal temperatures for BIRDS should be 170F to 180F and meat should be 140F for rare, 160F medium and 170F for well done.

MARINATED FLANK STEAK: Mix marinade ingredients in nonmetal dish. Let steak stand in marinade for no less than 4 hours in refrigerator. Brown each side for 5 minutes, but center should remain rare. Cut steak diagonally across the grain into thin slices before serving. Grill with fire grate in high (hot) position with lid open or closed.

MARINADE: 1/2 cup vegetable or olive oil, 1/3 cup soy sauce, 1/4 cup red wine vinegar, 2 tbs. Lemon juice, 1 tsp. Dry mustard, 1 minced clove garlic, 1 small minced onion, 1/4 tsp pepper.

QUAIL OR DOVES: Cover birds in Italian dressing (Good Seasons or Kraft Zesty), marinate overnight, pour off dressing and cover with Texas Pete Hot Sauce for 6 hours. Wrap birds in thick bacon secured by a toothpick. *Place on grill – keep turning until bacon is black. Grill for 20 minutes. Sear with lid open and fire grate in high (hot) position for 1 min each side before lowering grate and closing lid. *OR SMOKE by placing birds in center of GRID with fire in both ends of FIRE BOX.

KABOBS: Alternating on skewers any combination of meat, onions, tomatoes, green peppers, mushrooms, zucchini, circular slice of corn-on-the-cob, or pineapple. Meat could consist of chunks of shrimp, scallops, lobster, chicken, sausage, pork, beef, etc.

Marinate the meat in refrigerator for several hours. Grill each side approximately 7 minutes turning occasionally while

basting with marinade. Leave a small amount of room between pieces in order to cook faster. Grill with lid up and

the fire grate in the lowest position. See marinade recipe on last page.

KABOB MARINADE: Mix 1 cup soy sauce, 1/2 cup brown sugar, 1/2 cup vinegar, 1/2 cup pineapple juice, 2 teaspoons salt, 1/2 teaspoon garlic powder and bring to a boil. Marinate beef in mixture a minimum of 4 hours.

HOT DOGS: Grill with lid up and fire grate in high (hot) position for approximately 6 minutes, turn every few minutes.

HAMBURGERS: Mix in chopped onions, green peppers, salt, sear 3/4 inch patties on each side with fire grate in high position for a few minutes. Lower fire grate to medium position and grill with lid down to avoid flare-ups. Cook each side 3 to 7 minutes according to desired doneness. Cook ground meat to 150 internally or until juice runs clear (free of blood) for prevention of E-coli.

Burgers can be basted with marinade when turning and/or other ingredients can be mixed in with the ground beef such as chili sauce or powder; or you may marinate by allowing to stand in marinade for 1 or 2 hours at room temperature before cooking; or let stand in covered dish in refrigerator up to 24 hours. Bring to room temperature before cooking.

See meat marinade on page 9.

SHRIMP (Peeled) & Crayfish: Place on skewers, coat with melted butter and garlic salt. Grill 4 minutes on each side or until pink. Cocktail sauce optional.

BAKED POTATOES: Rub with butter and wrap in foil and cook on grill with lid down for 50 minutes. Turn after 25 minutes (no need to turn if smoked). Squeeze to check for doneness.

SWEET CORN IN HUSKS: Trim excess silk from end and soak in cold salted water 1 hour before grilling. Grill 25 minutes – turning several times.

SMOKIN' RECIPES: using the Charcoal Grill side of the Duo with a **WATER PAN** (also called **INDIRECT METHOD**).

Pan not included. Disposable bread pan is recommended. **SMOKE BY COOKING SLOWLY** (See chart on page 27 for smoking times). 1) Place water/drip pan on left side of fire grate. 2) Place hot coals on right side (damper end) of fire grate. The charcoal basket accessory helps confine coals to one side. 3) Place meat above water pan. 4) Place fire grate in low position. 5) Close lid & control heat with dampers & adjustable grate.

You may want to sear certain foods before smoking by placing meat directly above coals with **LID** open and **FIRE GRATE** in high (hot) position for several minutes. Add flavor soaked wood chips to the fire and add 1 part marinade, beer or wine to 3 parts water to the drip pan. **OPENING THE SMOKING CHAMBER WILL EXTEND COOKING TIME.** Cooking with meat thermometer ensures food is fully cooked. Insert thermometer into thickest part not touching bone, and allow five minutes to register. Internal temperature for birds should be 170F to 180F or when leg moves easily in joint. Meat should be cooked to internal temperature of 140F for rare, 160F for medium and 170F for well done. Check the water level when cooking more than 4 hours or when you can't hear the water simmering. Add water by moving meat over and pouring water through GRILL into WATER PAN. **IF THE SMOKE IS WHITE, THE FIRE'S RIGHT. IF THE SMOKE IS BLACK, ADD SOME DRAFT.**

SMOKED TURKEY: Empty cavity rinse and pat dry with paper towel, tuck wing tips under the back and tie legs together. Place in center of cooking grid directly above foil drip pan of water. Smoke for 12 minutes per pound. Allow several extra minutes per pound if stuffed to allow for expansion. Use a meat thermometer for best results (190F internal).

SMOKED BAKED HAM: Fully cooked canned ham or smoked and cured whole ham or shank or butt portion. Place fire grate in the lowest position and a drip pan under the meat. Remove rind and score fat diagonally to give a diamond effect. Insert a whole clove in to the center of every diamond. Place ham with fat side up in center of cooking grid directly above drip pan. Close lid. About 9 minutes per pound is suggested for fully cooked hams. Smoked or cured ham which is not fully cooked should be cooked to an internal temperature of 160°. Baste with ham glaze 3 or 4 times during last 30 minutes of cooking time. Garnish with pineapple rings about 15 minutes before end of cooking time.

HAM GLAZE: 1 cup of light brown sugar, firmly packed, 1/2 cup orange juice, 1/2 cup honey, combine sugar, juice and honey. Let marinade sit for at least 4 hours.

SMOKED HOT DOGS STUFFED: Slit hot dogs lengthwise, within 1/4 inch of each end. Stuff hot dogs with cheese and relish and wrap in bacon. Place on cooking grid over drip pan and smoke 15-20 minutes or until bacon is crisp.

SMOKED CHICKEN PARTS AND HALVES: Rinse pieces in cold water and pat dry with paper towels. Brush each piece with vegetable oil and season to taste with salt and pepper. Brown pieces directly above coals with lid open and grate in high or medium position for several minutes. Then place pieces on cooking grate directly above drip pan. With the grate in the low position, cook with lid down for 55 to 60 minutes or until done. Do not use vegetable oil or salt and pepper if using marinade.

SMOKED VENISON: Place leg of venison in a container or "hefty bag" and marinate for 2-4 days, turning daily. Marinate bacon overnight in its marinade. Remove roast from refrigerator at least an hour before cooking. Season generously with seasoned salt and coarse ground black pepper. Wrap 1 lb. Bacon over the top of the roast, and smoke 20/25 minutes per pound, or until tender. Do not overcook.

Venison Marinade: 1 cup Balsamic or wine vinegar, 1 cup olive oil, 2 oz. Worcestershire, 1/2 oz. Tabasco, 2 tbs. Season All, 1 to 2 chopped jalapenos, 3 oz. Soy sauce.

Bacon Marinade: 2 ox. Wine vinegar, 2 oz. Worcestershire, 4 dashes Tabasco.

SMOKED SHRIMP & CRAYFISH: Mix in a foil pan 1/2 cup butter, two cloves of crushed garlic, Tabasco, sliced green pepper, 1 tablespoon each of minced onions, salt and juices from one lemon. Add shrimp and/ or crayfish and smoke 45 minutes.

SMOKED VEGETABLES: Turnips, potatoes, carrots, okra, mushrooms, peeled onions, zucchini, squash, etc. Put in pan and cover with water and cook for several hours while cooking the meat. Or place vegetables on grill and smoke for 50 minutes, either wrapped in foil or not.

SMOKED FISH: Marinate in brine (1/4 cup dissolved in 1 qt of water) or marinate fish in 1 cup white wine, 1 cup soy sauce mixed with 1 cup lemon juice. Marinate overnight in covered dish in refrigerator. Let air on rack 20 minutes before placing on Pam sprayed grill. Smoke 25 minutes.

SMOKED SPARE/BACK RIBS: Peel off tough layer of skin on back side. Rub all surfaces with seasoning. Place ribs in center of grid above drip pan and smoke approximately 1 1/2 hours or until meats pulls away from bone. Baste with barbecue sauce during last 30 minutes.

CHICKEN MARINADE: Combine 1/2 cup soy sauce, 1/4 cup vegetable oil, 1/4 cup red wine vinegar, 1 teaspoon oregano, 1/2 teaspoon sweet basil, 1/2 teaspoon garlic powder with parsley, 1/4 teaspoon pepper. Pour over chicken pieces in nonmetal dish. Cover and refrigerate overnight, turning occasionally. Use marinade to baste chicken while cooking.

MEAT MARINADE: For steaks, chops, and burgers: Combine 1 cup soy sauce, 2 coarsely chopped large onions and 2 cloves garlic (halved) in an electric blender; cover, process at high speed 1 minute or until mixture is very smooth. Stir in 1/4 cup bottle gravy coloring (Kitchen Bouquet and Gravy Master) and 2 teaspoons Beau Monde seasoning (or substitute 1 teaspoon MSG and 1 teaspoon seasoned salt). Allow meat to stand in marinade at room temperature for 2 hours or refrigerate up to 24 hours in a covered dish. Bring meat to room temperature before cooking.

SHISH KABOB MARINADE: Mix 1 cup soy sauce, 1/2 cup brown sugar, 1/2 cup vinegar, 1/2 cup pineapple juice, 2 teaspoons salt, 1/2 teaspoon garlic powder and bring to a boil. Marinate beef in mixture a minimum of 4 hours.

SMOKING TIMES



Food	Weight	Water Pan Smokin'	Side Fire Box	Temperature on Meat Thermometer
Beef Roasts, Beef Brisket	3 – 4 lbs.	1 – 1½ hours	4 – 5 hours	140° rare
Lamb Roasts, Venison	5 – 7 lbs.	1¾ – 2½ hours	5 – 6 hours	160° medium
Large cuts of Game	7 – 9 lbs.	2½ – 3½ hours	7 – 10 hours	170° well done
Pork Roasts	3 – 4 lbs. 5 – 8 lbs.	1¾ – 2½ hours 2½ – 3 hours	5 – 6 hours 7 – 8 hours	170° 170°
Pork/ Beef Ribs	Full grill	1½ – 2 hours	4 – 6 hours	Meat pulls from bone
Pork Chops	Full grill	¾ – 1¼ hour	4 – 6 hours	Meat pulls from bone
Sausage Links	Full grill	2 – 2¾ hours	4 – 5 hours	170° for fresh sausage
Ham, Fresh	10 lbs.	3 – 4 hours	7 – 8 hours	170°
Ham, Cooked	All sizes	1½ – 2 hours	3 – 4 hours	130°
Chicken (Cut up or split)	1-4 fryers, cut up or split	1 – 1¼ hours	4 – 5 hours	180° / leg moves easily in joint
Chicken (Whole)	1-4 fryers	1¼ – 1½ hour	5 – 6 hours	180° / leg moves easily in joint
Turkey (Unstuffed)	8 – 12 lbs.	1¾ – 2½ hours	7 – 8 hours	180° / leg moves easily in joint
Fish, small whole	Full grill	½ – ¾ hours	2 – 3 hours	Flakes with fork
Fish, filets, steak	Full grill	¼ – ½ hours	1 – 3 hours	Flakes with fork
Duck	3 – 5 lbs.	1 – 1¾ hours	5 – 6 hours	180° / leg moves easily in joint
Small game birds	Full grill	¾ – 1 hour	4 – 5 hours	180° / leg moves easily in joint

Duo 5050

ACCESSORIES ORDER FORM



TO ORDER

Visit:

www.chargriller.com

or

CALL: 912-638-4724

or

FAX: 912-638-2580

or **MAIL:**

P.O. Box 30864

Sea Island, GA

31561



FedEx



Visit our online store at:

www.chargriller.com

for more Char-Griller®

Professional Accessories™

Professional Accessories™ Branded with Char-Griller® Logo

ALL TOOLS: STAINLESS STEEL & HARDWOOD HANDLES

• Cover

- Custom Fit, Weather Resistant
- Protects grill finish
- Cover Accommodates Side Shelf or Side Fire Box
- Grill cover #8080 fits with Side Fire Box or Side Shelves.....\$34.99



• Side Fire Box item #2-2424

- For Charcoal grilling
- Attaches to grill in minutes.....\$59.99



• Rotisserie—Heavy Duty

- Excellent for effortless grilling
- Universal Fit for Any Grill.....\$35.99



• Apron

- Machine Washable
- Two Front Pockets
- Adjustable Straps.....\$14.99



• Tank Cover

- Weather Resistant Nylon
- Velcro Close
- Elastic at Top and Bottom
- Cover Only Tank Not Included.....\$9.99



(continued on next page)

Page intentionally left blank for notes



**P.O. Box 30864
Sea Island, GA 31561
912-638-4724
www.CharGriller.com**

Warranty Information – Gas Grill

Char-Griller® will repair or replace any defective part of its Grills for a period of up to one year from the date of purchase.

Char-Griller® will also repair or replace the charcoal grill body (lid and bottom half) and gas grill lid of its grillers/smokers if the metal is rusted through or burned through for a period up to five years from date of purchase.

Char-Griller® will repair or replace the gas grill body if the metal is rusted through or burned through for a period up to one year from date of purchase.

Char-Griller® gas grill burners have a five year warranty from the date of purchase.

Proof of purchase, proof of purchase date and prepaid return of the item in question may be required. Misuse, abuse, or commercial use nullifies all warranties. Paint/finish is not warranted. Products are not warranted against rust.

The warranty is for replacement of defective parts only. Manufacture will not be responsible for damage resulting from accident, alteration, misuse, abuse, hostile environments, improper installation, installation not in accordance with local codes of service of unit.

This limited warranty does not cover any scratches, dents, corrosion or discoloring by heat, abrasive and chemical cleaners nor any components used in the installation of the appliance.

Save your receipt for all warranty claims.



**P.O. Box 30864
Sea Island, GA 31561
912-638-4724
www.CharGriller.com
Service@CharGriller.com**



Free Manuals Download Website

<http://myh66.com>

<http://usermanuals.us>

<http://www.somanuals.com>

<http://www.4manuals.cc>

<http://www.manual-lib.com>

<http://www.404manual.com>

<http://www.luxmanual.com>

<http://aubethermostatmanual.com>

Golf course search by state

<http://golfingnear.com>

Email search by domain

<http://emailbydomain.com>

Auto manuals search

<http://auto.somanuals.com>

TV manuals search

<http://tv.somanuals.com>