

# OWNER'S MANUAL

A guide to your intelligent floor cleaner

Junior™ by bObsweep

Model No. WJ540011

## Congratulations!

Congratulations on your new intelligent floor cleaner! Junior is now at your service. To see Junior at his best, please read the Quick Start Guide and this manual thoroughly. Welcome to the bObsweep family and happy cleaning!

If you have any questions or concerns, feel free to contact our helpful team at: [support@bobsweep.com](mailto:support@bobsweep.com).

6

Important Safety  
Instructions

8

What Comes in  
Junior's Box?

10

Junior's Anatomy

33

Maintenance

Dustbin [34](#)  
Filters [36](#)  
Main Brush [38](#)  
Side Brush [40](#)  
Sensors [41](#)  
(De)Reactivate Edge  
Sensors [42, 43](#)  
Battery [44](#)

47

Trouble Shooting  
& Checkup Test

Troubleshooting [48](#)  
Home Checkup  
Test [53](#)

63

Warranty  
Information

13

Cover Buttons

15

Get Junior Ready  
to Clean

Install Side Brush [16](#)  
Charge Junior [17](#)  
Sync Junior's Charging  
Station & Remote [19](#)  
Junior's First Clean [21](#)

23

Charging Station  
& Remote Control

Charging Station  
Placement [24](#)  
Auto Charging [25](#)  
Manual Charging [26](#)  
Conserving Battery [27](#)  
Remote Control [28](#)  
Syncing Junior's  
Remote [31](#)

64

Cleaning Behavior  
& Challenges

67

FAQs

72

End User License  
Agreement

## Important Safety Instructions

Always follow basic safety precautions, including:

Read ALL instructions before use.

To protect against electrical shock, do not immerse any part of Junior in water or other liquids.

Unplug Junior from the wall outlet when he is not in use and before conducting maintenance.

Do not operate Junior or his charging station if they have been damaged in any way. If Junior is not working as he should, or has been dropped, damaged, left outdoors, or dropped in water, contact our customer care center at [support@bobsweep.com](mailto:support@bobsweep.com).

Do not handle Junior or his charging station with wet hands; use only on dry surfaces.

Do not use Junior outdoors.

Junior is not intended for use by persons (including children) with reduced physical or mental capabilities, or lack of experience and knowledge, unless under the close supervision of a person responsible for their safety.

Do not pull or carry the charging station by the cord, use the cord as a handle, close a door on the cord, or pull the cord around sharp edges or corners. Keep the cord away from heated surfaces. To unplug the cord, grasp the plug, not the cord itself.

Do not mutilate or incinerate the battery, as it will explode at high temperatures.

Do not attempt to open Junior's charging station. Repairs on his station should only be carried out by our qualified customer care center.

Do not expose Junior's charging station to high temperatures or allow moisture or humidity of any kind to come into contact with it.

Do not let Junior pick up toxic materials (chlorine bleach, ammonia, drain cleaner, etc.).

Do not let Junior pick up anything that is burning or smoking, such as cigarettes, matches, or hot ashes. Do not use Junior to pick up flammable or combustible liquids such as gasoline, nor use him in areas where they may be present.

Do not use Junior in an enclosed space filled with vapors given off by oil-based paint, paint thinner, moth-proofing substances, flammable dust, or other explosive or toxic

vapors.

Leaks from battery cells can occur under extreme usage or temperature conditions. If the liquid gets on skin, wash quickly with water. If the liquid gets into the eyes, flush them immediately with clean water for a minimum of 10 minutes, and seek medical attention.

Do not use Junior for anything other than his intended purpose, as specified in this manual.

### Declaration of Conformity

This device complies with Part 15 of the FCC rules. Operation is subject to the following two conditions: (1) this device may not cause harmful interference, and (2) this device must accept any interference received, including interference that may cause undesired operation.

The manufacturer is not responsible for any radio or TV interference caused by unauthorized modifications or change to this equipment. Such modifications or change could void the user's authority to operate the equipment.

This equipment has been tested and found to comply with the limits for a Class B digital device, pursuant to part 15 of the FCC Rules. These limits are designed to provide reasonable protection against harmful interference in a residential installation. This equipment generates, uses and can radiate radio frequency energy and, if not installed and used in accordance with the instructions, may cause harmful interference to radio communications. However, there is no guarantee that interference will not occur in a particular installation. If this equipment does cause harmful interference to radio or television reception, which can be determined by turning the equipment off and on, the user is encouraged to try to correct the interference by one or more of the following measures:

- Reorient or relocate the receiving antenna.
- Increase the separation between the equipment and receiver.
- Connect the equipment into an outlet on a circuit different from that to which the receiver is connected.
- Consult the dealer or an experienced radio/TV technician for help.

## What Comes in Junior's Box?

Junior, Your Intelligent Floor Cleaner **1**

Charging Station **2**

Spare Main Brush **3**

Charging Adapter **4**

Remote Control **5**

Screwdriver **6**

2 Side Brushes (1 Spare) **7**

Cleaning Tool **8**

Pack of Screws **9**

Filter Replacement **10**

Owner's Manual, Quick Start Guide, Warranty Card **11**

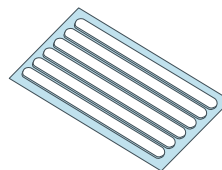
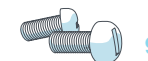
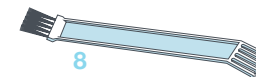
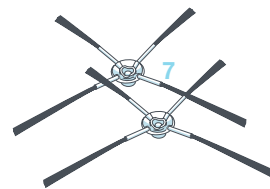
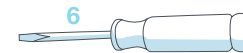
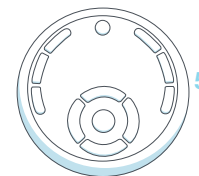
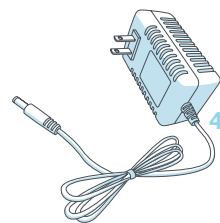
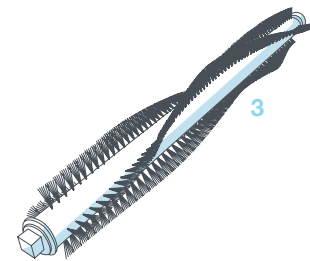
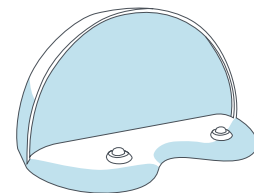
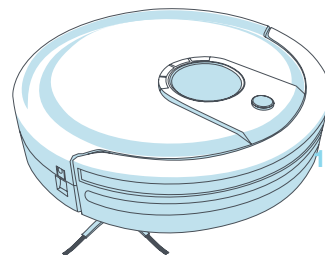

## Junior's Anatomy

### Top View

Bumper **1**

Signal Transmitter **2**

Display **3**

Cover Buttons **4**

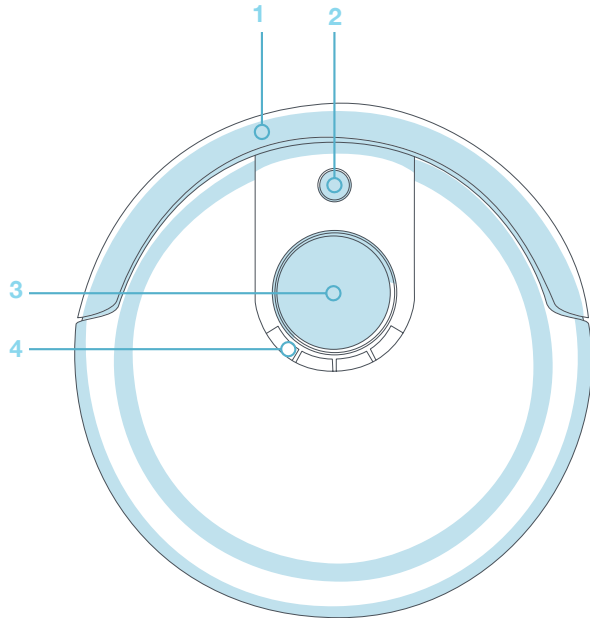

### Bottom View

Charging Plates **1**

Front Wheel **2**

Side Brush **3**

Battery **4**

Main Brush **5**

ON/OFF Switch (on Junior's side) **6**

Charging Inlet (on Junior's side) **7**

Left and Right Wheels **8**

Dustbin **9**

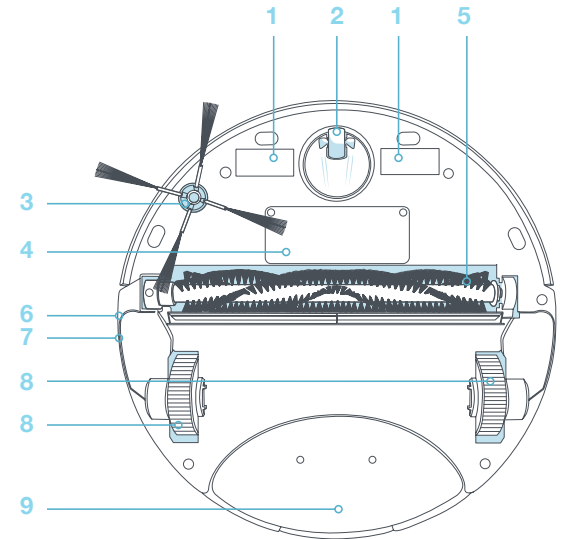

Remote Control **1**

Charging Station **2**

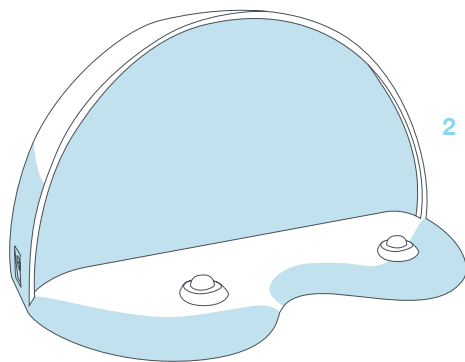
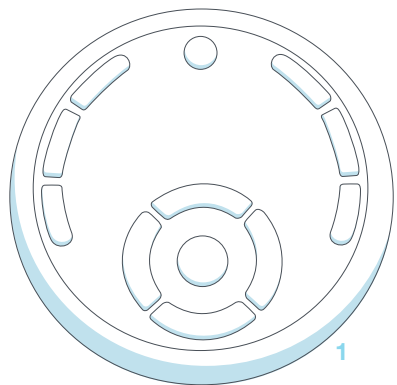

Cover Buttons

**GO! 1**

Junior will clean on his default setting

**WAFFLE 2**

Send Junior to his charging station

**MUTE 3**

Mute Junior's beeping

**CHECKUP 4**

Put Junior in checkup mode / Deactivate edge sensors (page 59)



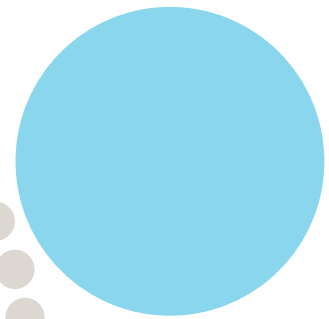
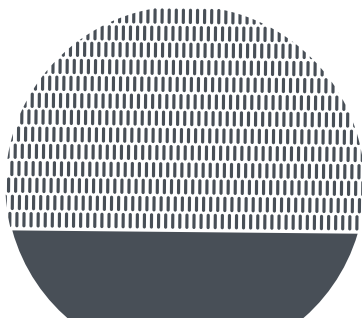
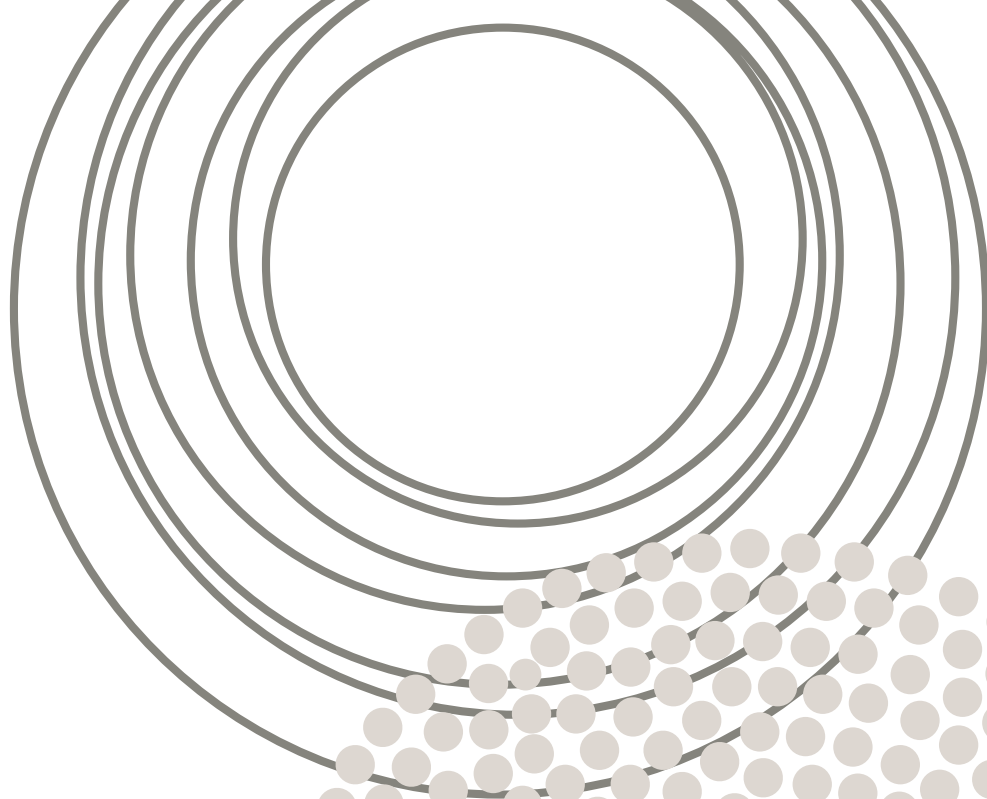
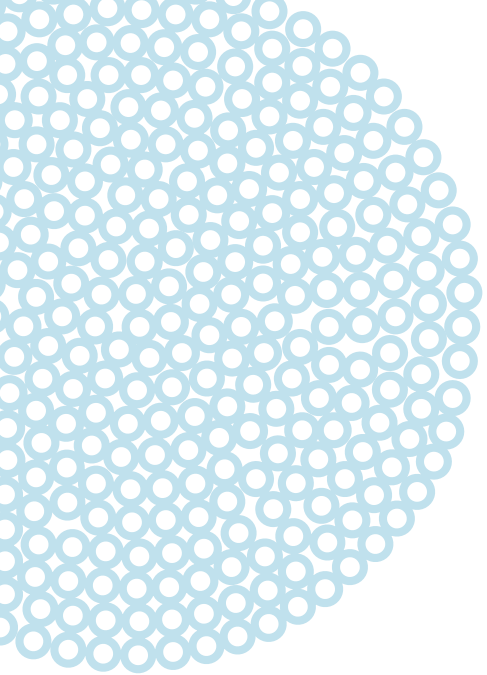

**Getting Junior  
Ready to Clean**



## Install Junior's Side Brush

Before Junior's first clean, you must install his side brush, which allows him to sweep along corners, walls, and other hard-to-reach places.

To do this, you will need the following materials, all of which are included inside Junior's box: a side brush, a flat head screwdriver, and a short screw.

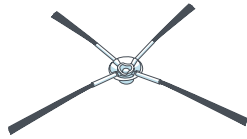
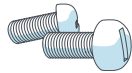

1

Flip Junior over onto a flat surface. Place the side brush over the empty socket on Junior's underside.

2

Secure Junior's side brush onto the socket using the flat head screwdriver and short screw.

3

You may use the additional side brush and screws as spares.

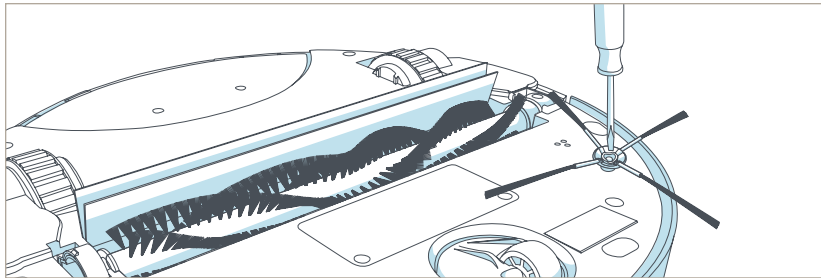

## Charge Junior

After installing Junior's side brush, you must now set him to charge.

1

Plug the charging adapter into Junior's side. Junior will chirp and start charging.

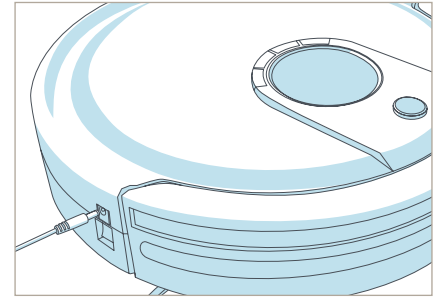

OR

1

Plug the charging adapter into the side of the charging station. The station's red power light will turn on.

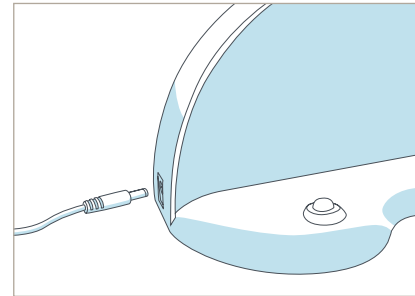

2

Place Junior on his charging station with the metal plates on his underbelly sitting on top of the nodes on his station.

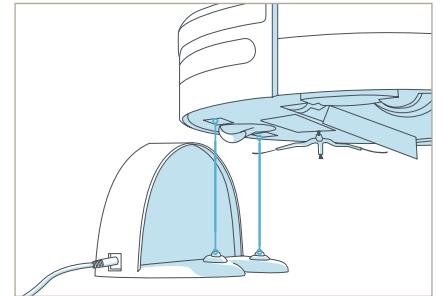

## Sync Junior's Charging Station and Remote

3

When Junior is charging, the battery bars on his display screen will flash and the word "Charging" will appear.

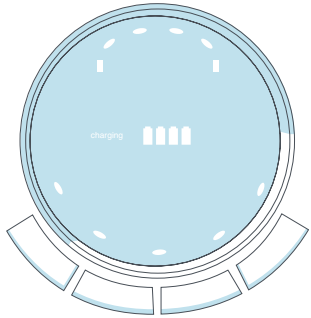

4

When Junior has fully charged, the battery bars will remain still and the word "Charging" will disappear.

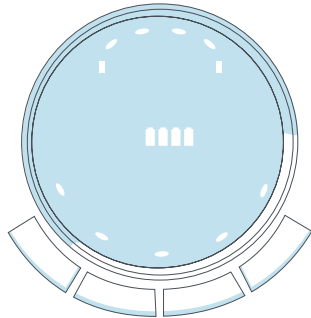

Junior automatically returns to his charging station when his battery reaches 15%. If Junior has trouble finding his station, it likely needs to be synced.

To sync the charging station:

1

While the station is plugged in, hold down the SYNC button on the back of it.

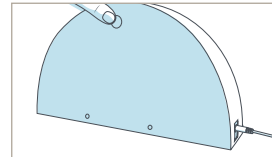

2

While still holding down the SYNC button, flip Junior's power switch ON.

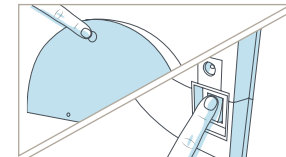

3

Junior will chirp twice to let you know the sync was successful.

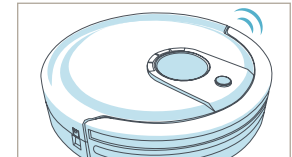

Junior's remote runs on 2 AAA batteries (not included). If Junior is not responding to his remote, it likely needs to be synced.

To sync the remote:

1

Hold down the PAUSE button on Junior's remote.

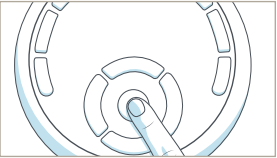

2

While still holding down the PAUSE button, flip Junior's power switch ON.

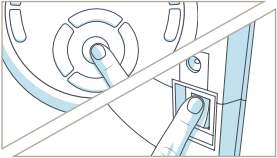

3

Junior will chirp twice to let you know the sync was successful.

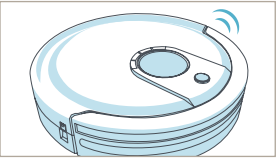

Junior is now ready to clean!

Press the GO! button on his cover — or on his remote — and he will clean on his default setting.

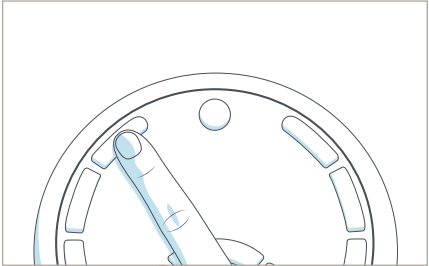
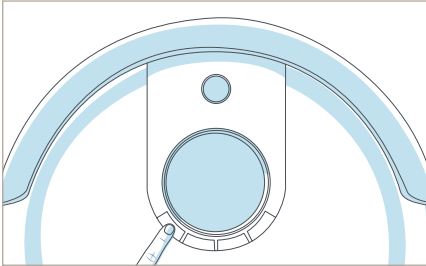

The image features a white background with several abstract elements. In the top left, there is a semi-circular cluster of light blue circles. In the center, a large circle is defined by multiple concentric grey lines. Below this, a semi-circular area is filled with a pattern of grey circles. In the bottom left, a circle is divided horizontally, with the top half filled with a fine grid of grey lines and the bottom half solid dark grey. On the right side, there is a solid light blue circle. The text 'Charging Station & Remote Control' is positioned in the upper right quadrant, overlapping the concentric circle and the grey circle pattern.

# **Charging Station & Remote Control**

## Charging Station Placement

- Position the charging station against a wall on a hard, flat surface.
- Make sure there is at least 10 feet (3 meters) of open space to the front and 2 feet (0.5 meters) to the sides.

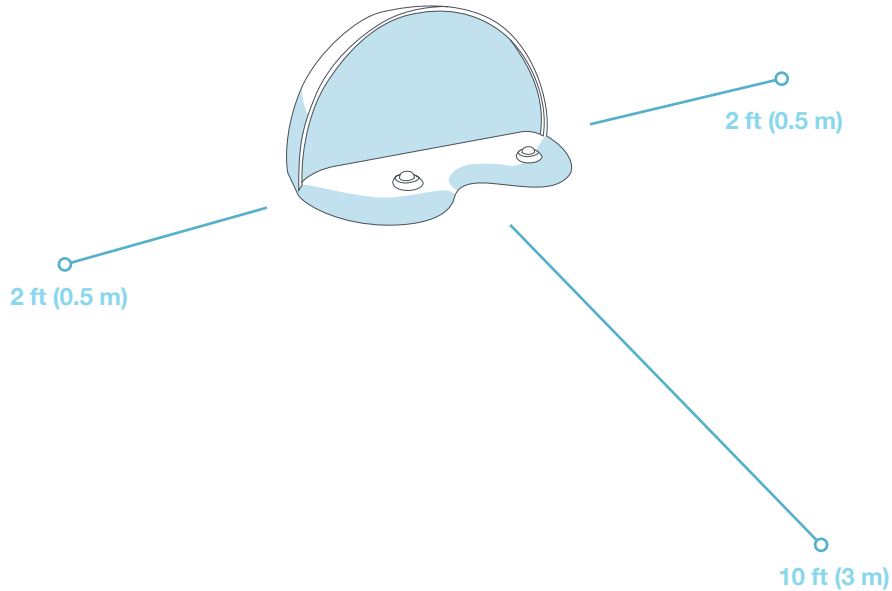

## Auto Charging

Junior is smart and automatically searches for his charging station when his battery reaches 15%. If Junior has trouble finding his station, it likely needs to be synced.

To sync the charging station:

1

Plug the charging adapter into the charging station. The station's red power light will turn on.

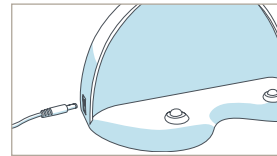

2

Hold down the SYNC button on the back of the charging station while at the same time flipping Junior's power switch ON.

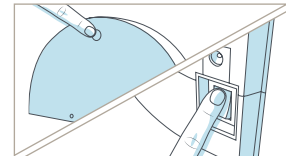

3

Junior will chirp twice to let you know the sync was successful.

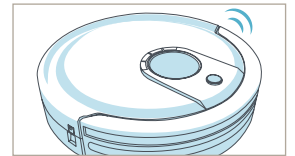

You can also direct Junior to his charging station at any time by pressing the CHARGE button on his remote.

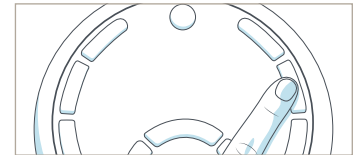

## Manual Charging

Using the charging station:

- Place Junior directly onto his plugged-in charging station.
- Make sure his charging plates sit directly on top of the nodes on his station.

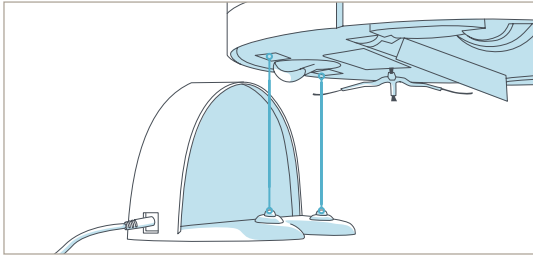

Using the adapter:

- Plug the charging adapter directly into the inlet on Junior's side.

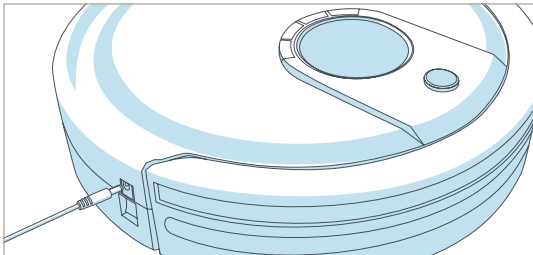

When Junior is charging, the battery bars on his display screen will flash and the word "Charging" will appear.

When Junior has fully charged, the battery bars will remain still and the word "Charging" will disappear.

## Conserving Junior's Battery

Junior should not sit on his charging station for more than 5 days. If you will not be using him at least once every 5 days, flip his side power switch OFF to conserve battery.

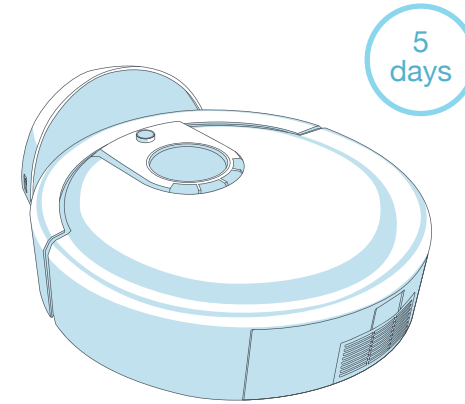

## Remote Control

Adjust Junior's cleaning speed, and control his movements from his remote control.

Power **1**

GO! **2**

Corner **3**

Mute **4**

Waffle **5**

Charge **6**

Speed **7**

Navigational Arrows **8**

Pause **9**

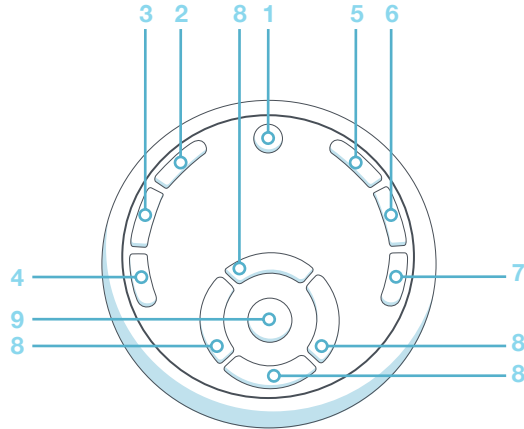

Junior's remote requires 2 AAA batteries (not included). Do not leave the batteries in the remote if you are not using it on a regular basis. Keep the remote at a normal room temperature.

Power

- Wakes Junior or puts him in standby mode

GO!

- Junior will begin cleaning

Corner

- Junior will start cleaning along corners and walls

Mute

- Mutes Junior's beeping while he is in standby mode

Waffle

- Junior will target a localized mess

While in standby mode, Junior will beep every 2 minutes to let you know that he is not fully powered off. To conserve Junior's battery, flip his power switch OFF, or press the MUTE button on his cover or remote to mute his beeping.

## Syncing Junior's Remote

### Charge

- Sends Junior to his charging station

### Speed

- Cycles through Junior's cleaning speeds

### Navigational buttons

- Guides Junior forward, backward, right, or left

### Pause

- Pauses or resumes Junior's movements



If Junior is not responding to his remote, it likely needs to be synced.

To sync Junior's remote:

1

Hold down the PAUSE button on Junior's remote.

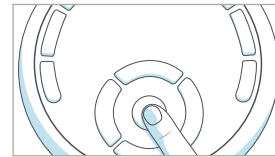

2

While still holding down the PAUSE button, flip Junior's power switch ON.

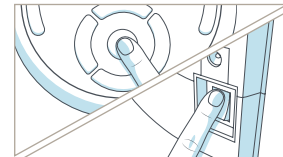

3

Junior will chirp twice to let you know the sync was successful.

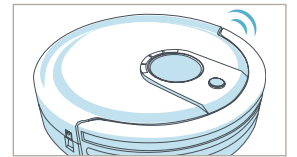



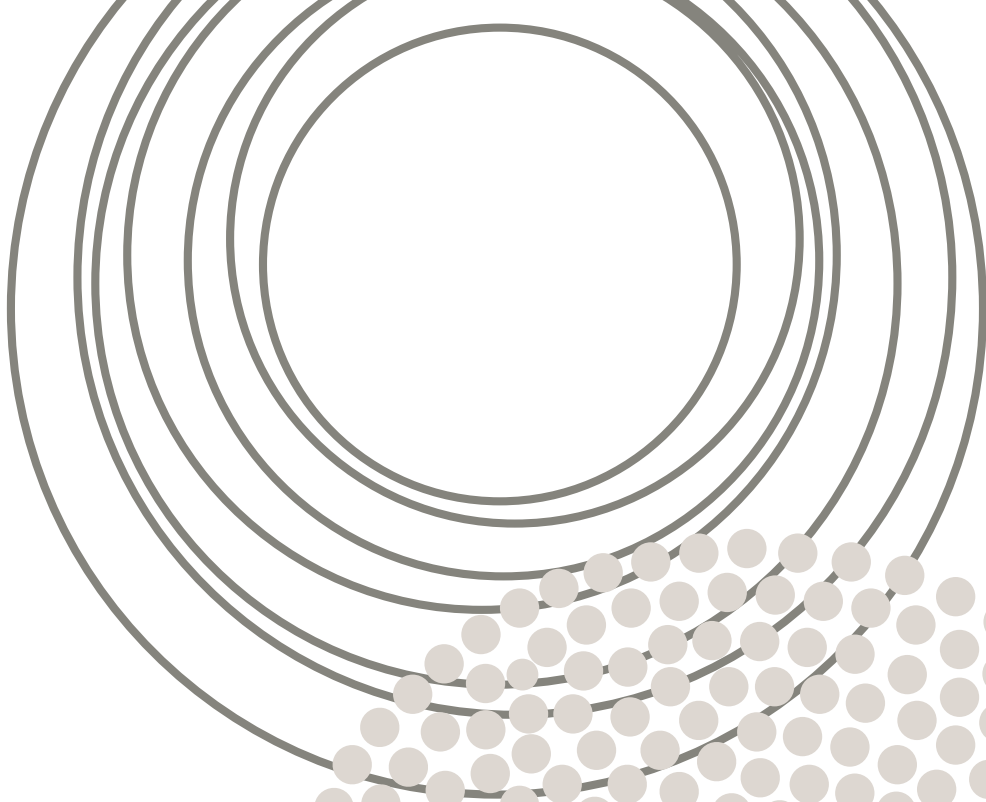
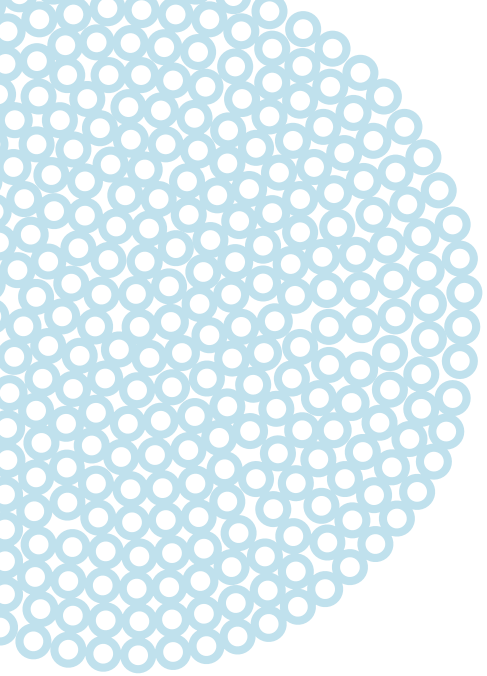

**Maintenance**

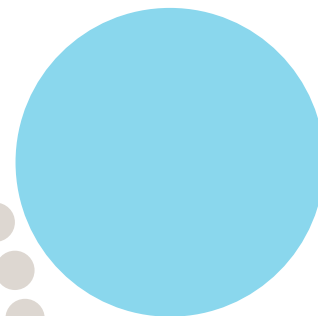
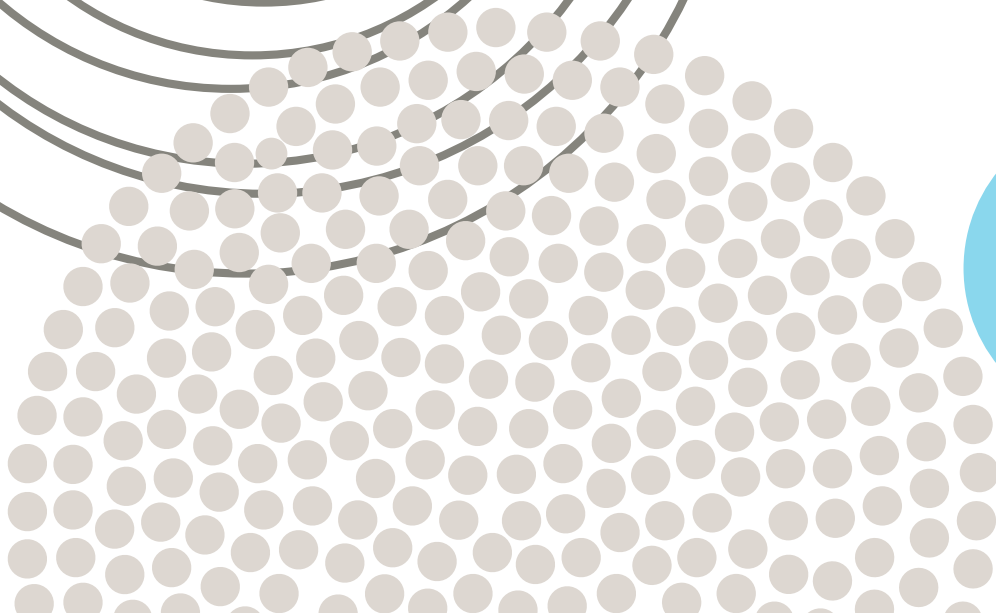
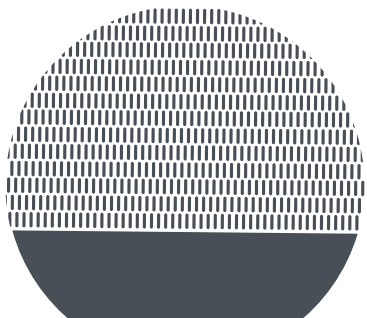

## Dustbin

To empty the dustbin:

1

Push the center black button on Junior's back to release the dustbin, and pull.

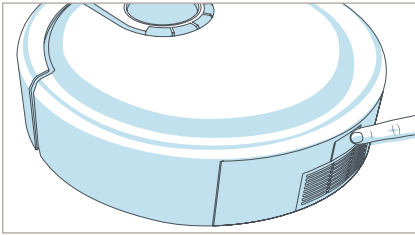

2

Open the transparent gate to empty the bin.

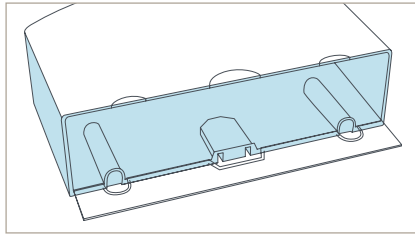

3

You may wipe the dustbin with a dry cloth or brush it with the cleaning tool.

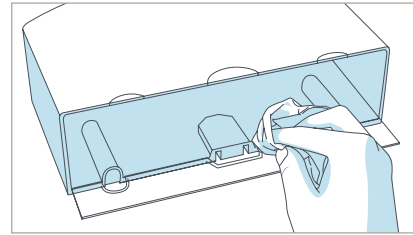

4

When done, replace the transparent gate and slide the dustbin back into Junior.

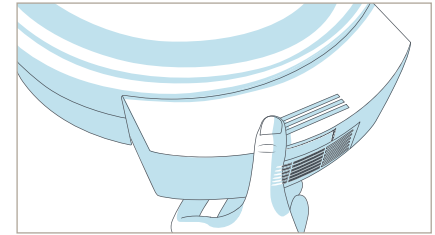

## Filters

Three filters are located inside the dustbin's ceiling. These filters capture fine particles and allergens, preventing them from escaping back into the air.

To remove the filters:

1

Eject the dustbin.

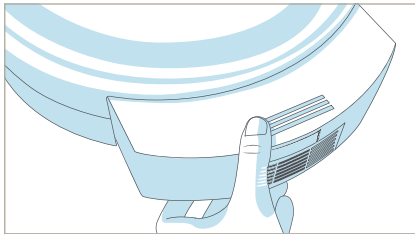

2

Pull the filter's frame towards you.

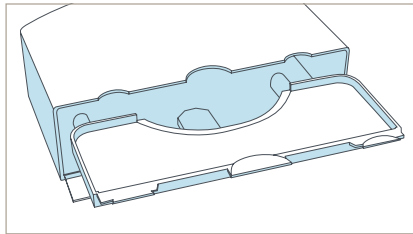

You will see three filter layers:

**Mesh filter 1**

for larger particles

**Electrostatic filter 2**

for fine particles

**HEPA filter 3**

for sub-micron particles

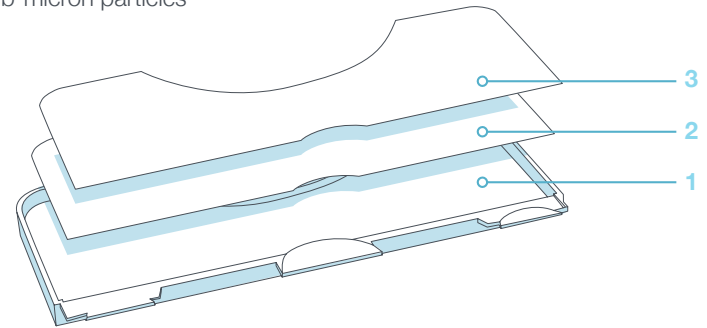

Use the cleaning tool to brush dust off the filters. It is recommended that you change Junior's filters every 6 months, depending on the frequency and intensity of his cleaning.

## Main Brush

It is recommended that you remove and clean Junior's main brush on a weekly basis.

To clean Junior's main brush:

1

Remove the screw securing Junior's main brush using a flat head screwdriver.

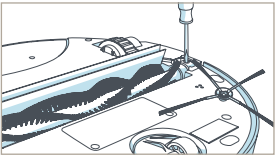

2

Use the cleaning tool to remove hair and debris from both ends of the brush as well as the compartment inside Junior.

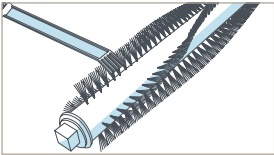

3

You may use a pair of scissors to cut away any hair or threads wrapped around the brush, or a pair of tweezers to remove congestion from the notches where the main brush is held.

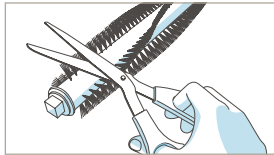

To reinstall the brush:

1

Replace the end piece and insert the opposite end of the brush into the square indentation inside Junior.

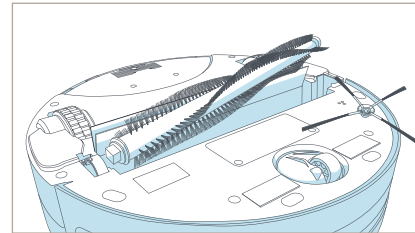

2

Lastly, re-tighten the screw.

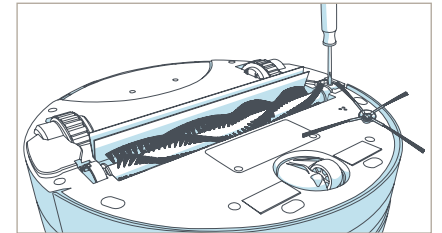

## Side Brush

It is recommended that you remove and clean Junior's side brush on a weekly basis.

To clean Junior's side brush:

1

Remove the side brush using a flat head screwdriver.

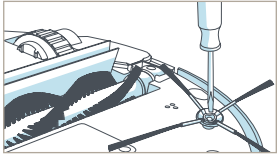

2

Use the cleaning tool to brush off hair tangled around the side brush as well as the socket where the side brush is held.

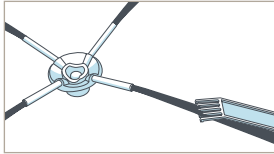

3

Replace the side brush and re-tighten the screw.

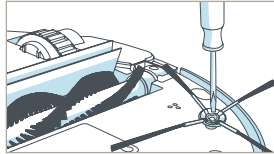

## Sensors

Dirt and dust on Junior's wall and edge sensors can reduce his performance. Regularly cleaning these sensors ensures that Junior keeps working at his best.

To clean Junior's sensors:

Gently wet a soft cloth with cold water or rubbing alcohol. Then, wipe the wall sensors along Junior's bumper and the oval-shaped edge sensors on his underside.

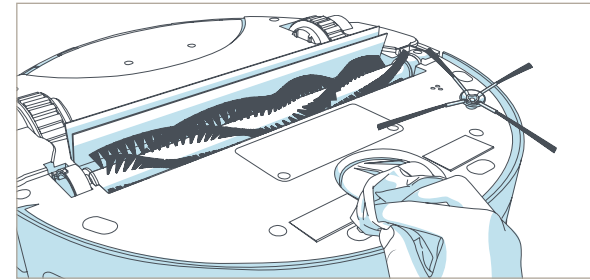

## Deactivate Edge Sensors

Dark-colored carpeting and certain floor patterns may seem like edges to Junior's edge sensors.

If you notice that Junior stops working on your carpet and displays that he feels "something funny going on" with his edge sensors, then you may need to temporarily deactivate them.

To deactivate Junior's edge sensors:

1

Flip Junior's power switch ON. Hold down the CHECKUP button on Junior's cover. The 4 bars at the top of the screen will begin to flash on Junior's screen.

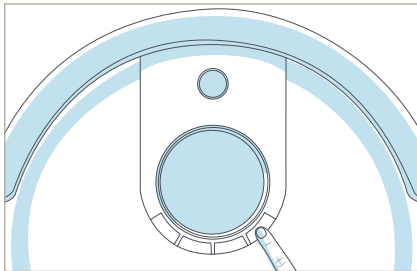

2

After the 4 bars flash 7 times and remain still, release the CHECKUP button. The 4 bars will remain lit. This means Junior's edge sensors are deactivated.

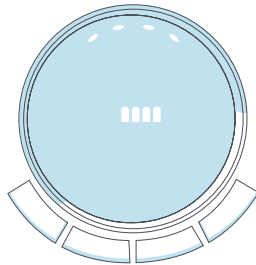

Caution: When you deactivate the edge sensors, Junior will not detect stairs or sharp drops.

To reactivate Junior's edge sensors:

1

Hold down the CHECKUP button on Junior's cover. The 4 bars above it will begin to flash on Junior's screen.

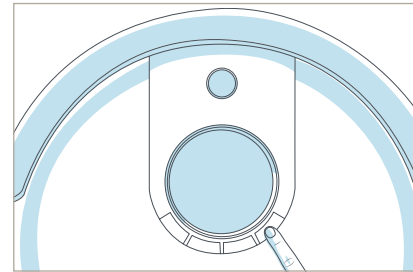

2

After the 4 bars stop flashing and disappear, release the CHECKUP button. Junior's edge sensors are active again.

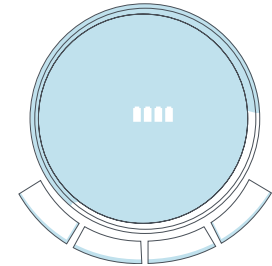

## Battery

To replace Junior's battery:

1

Remove the battery cover on Junior's underside using a Phillips head screwdriver.

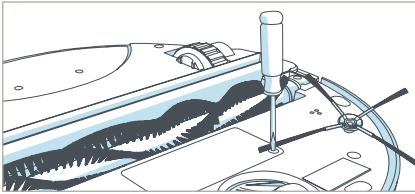

3

Plug the new battery in and slide it into the empty compartment.

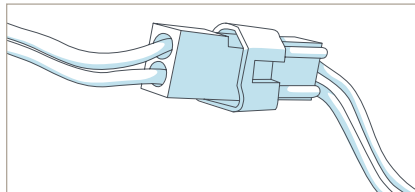

2

Lift the battery out of its compartment, and unplug the connecting wires.

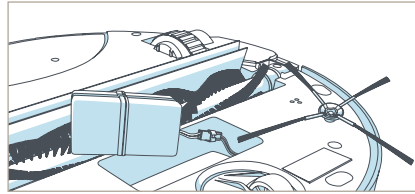

4

Re-tighten the screws on the battery cover.

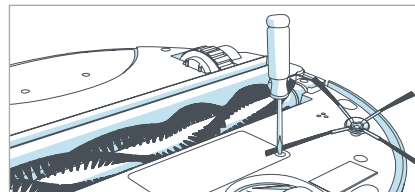

Do not let Junior sit idly with his power switch ON for more than five days; switch him OFF to conserve his battery.

To charge Junior's new battery:

Plug the charging adapter into Junior's side, Junior will chirp and start charging.

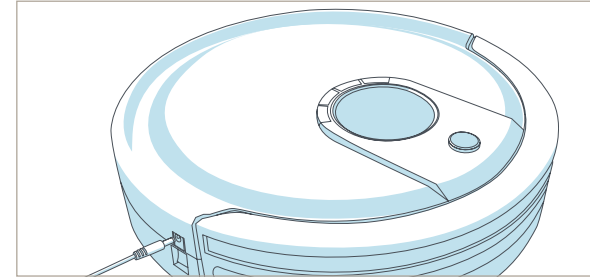

### Storing Junior

If you are not using Junior for an extended period of time, unplug his charging station, remove his battery, and store everything in a dry place at room temperature.

Do not leave Junior in direct sunlight.

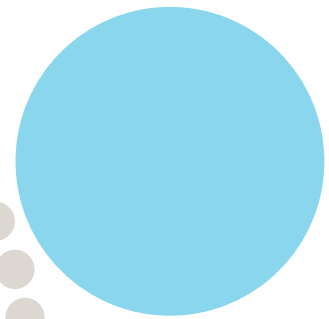
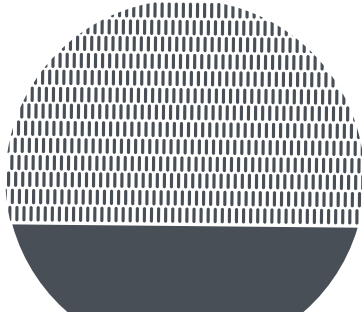
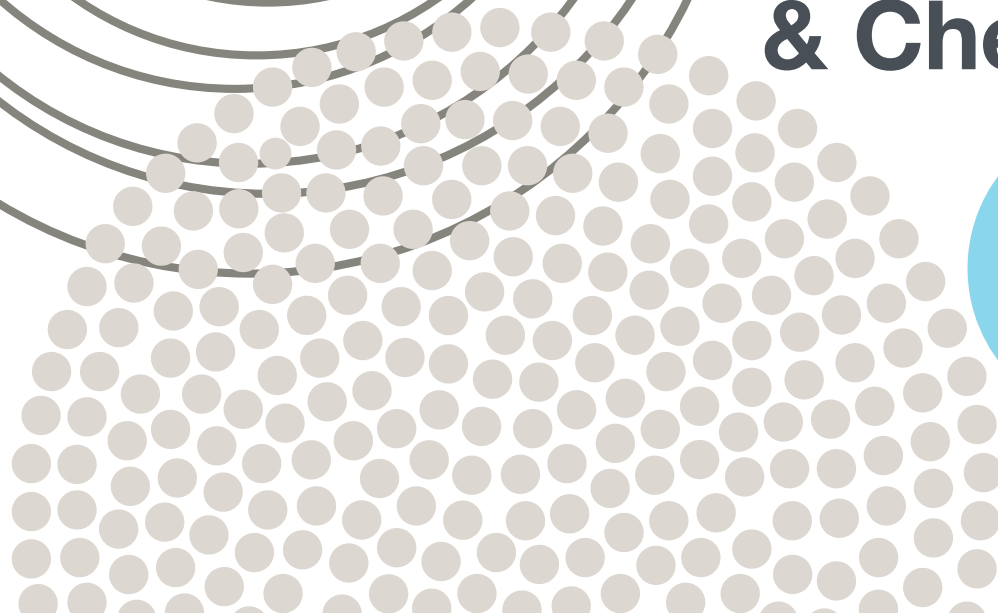
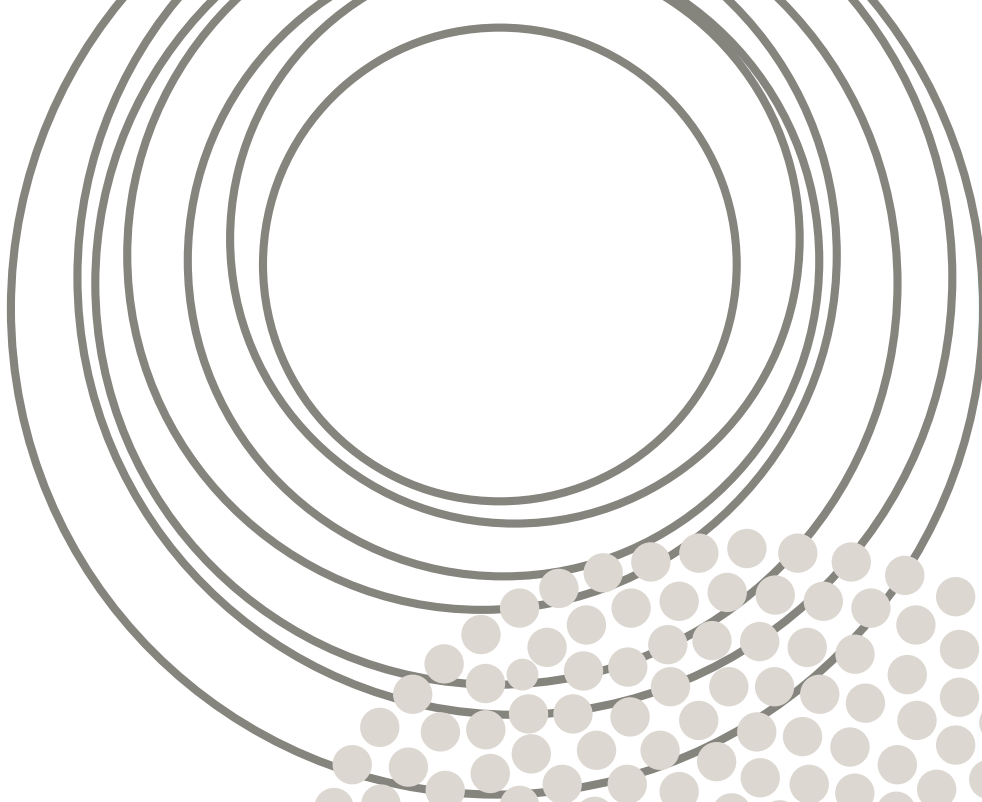
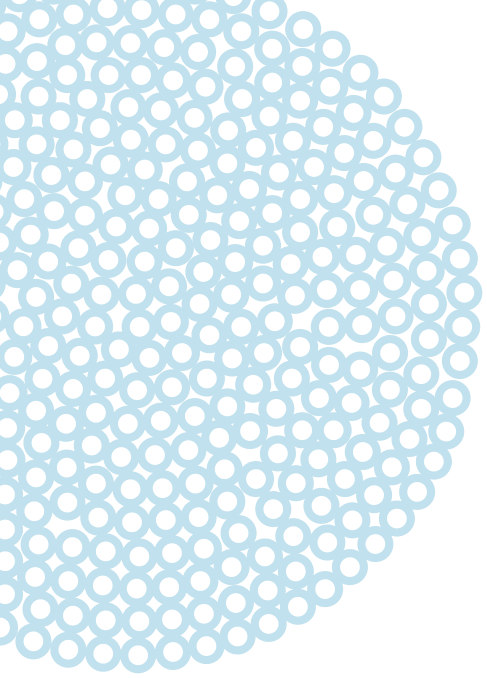

# Troubleshooting & Checkup Test



## Troubleshooting

When Junior is experiencing some difficulty, he will notify you by displaying on his screen “*Oops! I feel there’s something funny going on with my:*” along with the name of the part having an issue.

If after attempting the suggested solutions Junior’s problem persists, you may want to perform a home checkup test on him [see page 52]. You may also contact our customer care center at [support@bobsweep.com](mailto:support@bobsweep.com).



For handy video guides, visit [owners.bobsweep.com](http://owners.bobsweep.com), or scan this QR code:

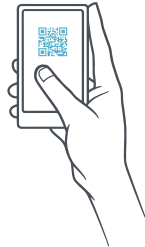

## Oops! I feel there’s something funny going on with my:

### Edge Sensors

The edge sensors are blocked or dirty. Junior’s four, oval-shaped edge sensors are located on his underside, near his bumper.

#### What to do:

- Clean the sensors using a clean, dry cloth or compressed air.

If Junior is continually having trouble with his edge sensors while working on dark-colored carpeting, you may need to deactivate them.

#### To deactivate Junior’s edge sensors (also on page 43):

- Hold down the CHECKUP button on Junior’s cover. The 4 bars above CHECKUP will then flash on Junior’s screen.
- After the bars flash 7 times and remain still, release the CHECKUP button.

Caution: When you deactivate the edge sensors, Junior will not detect stairs or sharp drops.

### Touch Sensors

There is a small piece of debris trapped underneath Junior’s bumper that is interfering with his touch sensors.

#### What to do:

- Slowly and carefully tap on Junior’s bumper to force the obstacle out.
- Use compressed air to clear out dust and debris trapped underneath the bumper.
- Press the corner ends of the bumper until you hear a tiny “click” sound. If the bumper is not clicking on its ends, the touch sensors may need to be replaced.

### Left Wheel

Something is blocking the left wheel.

#### What to do:

- Use the cleaning tool or compressed air to remove any dust or debris that may be jamming the left wheel.

### Right Wheel

Something is blocking the right wheel.

#### What to do:

- Use the cleaning tool or compressed air to remove any dust or debris that may be jamming the right wheel.

### Main Brush

The main brush is unable to move freely.

#### What to do:

- Remove the main brush using a flat head screwdriver, and clean it thoroughly from end to end.
- You may use a pair of scissors to cut hair or thread wrapped around Junior's brush, or a pair of tweezers to remove congestion from the square metal indentation where the main brush is held.



If Junior has trouble cleaning on shag carpet or rug, you may remove his main brush and allow him to vacuum without it.

### Wall Sensors

The wall sensors are blocked or dirty.

#### What to do:

- Do a visual check on the transparent strip on Junior's bumper. If it is too dirty for you to see what is behind it, wipe it with a clean, damp cloth.
- To ensure nothing is jammed under the bumper, gently tap it and use compressed air to clear it of debris.

### Dustbin

Junior's dustbin is not properly installed, or the metal contact points on the dustbin's bottom are dirty.

#### What to do:

- Remove Junior's dustbin and empty it.
- Turn the dustbin around and gently wipe the two metal connectors on its bottom.
- Lastly, clean the metal contact points in the space inside Junior where the dustbin is inserted.

### Power System

Junior's battery is disconnected or has absolutely no juice left.

#### What to do:

- Check Junior's battery connection.
- Place Junior directly onto his charging station and allow him to charge for a few hours.

If this fails to wake him, then Junior may need a new charging station.

#### What to do:

- Unplug the charging station and plug the adapter directly into the inlet on Junior's side. Allow him to charge for a few hours.

If connecting the charging adapter to Junior fails to wake him, he likely needs a new one.

## Home Checkup Test

If Junior is not performing as well as he used to, you can diagnose the problem with a simple home checkup test.

If Junior fails any part of the checkup test, he may need a replacement part. In this case, please call our customer care center at [1-888-549-8847](tel:1-888-549-8847) for toll-free support in the US and Canada, or email us at [support@bobsweep.com](mailto:support@bobsweep.com).

To put Junior in checkup mode:



Flip Junior's power switch OFF.

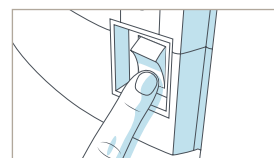

While holding down the CHECKUP button on Junior's cover, turn Junior's power switch ON.

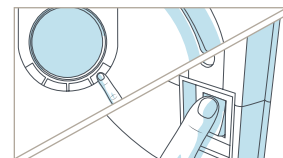

Junior will chirp three times to let you know he is now in checkup mode. Release the CHECKUP button. Do not press any additional buttons.

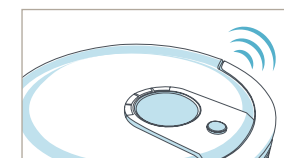

53

While in check-up mode, the "bObsweep" logo will flash on Junior's screen.

### Step One: Edge Sensors

The 4 bars at the top of the screen should be lit on Junior's display.

Lift Junior about 6 inches (15 cm) off the ground. You should see the 4 bars turn off.

If all 4 bars turn off while Junior is lifted, place Junior back on the floor and continue on to the next step without pressing any additional buttons.

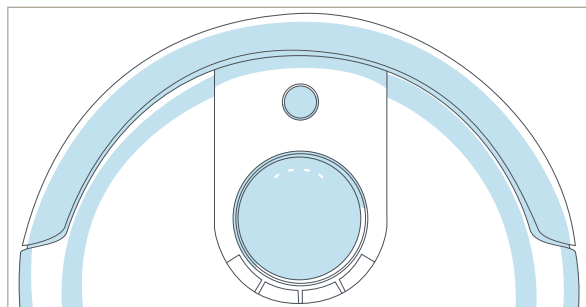

### Step Two: Wall Sensors

Use a thick, flat, and white surface to imitate a wall and drag it around Junior's bumper.

The 5 bars at the bottom of the screen should light up one at a time as you move your imitation wall around Junior's bumper.

If all 5 bars light up, you may move on to the next step of the checkup test. Do not press any additional buttons.

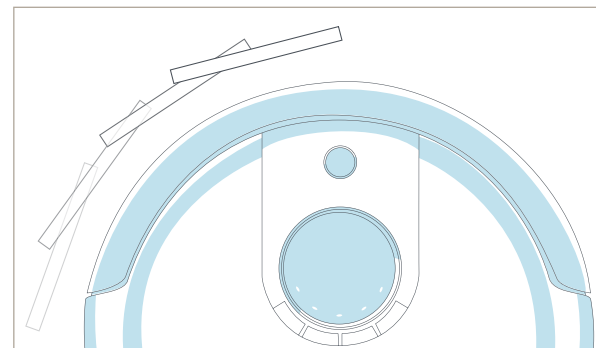

### Step Three: Touch Sensors

Press the left side of Junior's bumper and the left bar should light up; press the right side of the bumper and the right bar should light up.

Press the center of the bumper and both the left and right bars should light up at the same time.

If both bars light up correctly, you may move on to the next step of the checkup test.

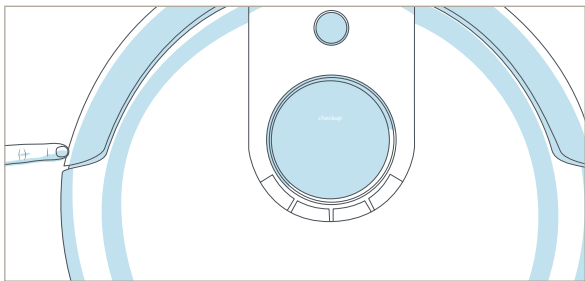

### Step Four: Charging Station

The charging station must be synced and plugged in for this step of the checkup test. Next, press the GO! button on Junior's cover.

Place Junior directly in front of his charging station, about 1 ft (0.3 m) away.

The four battery bars should be lit on Junior's display.

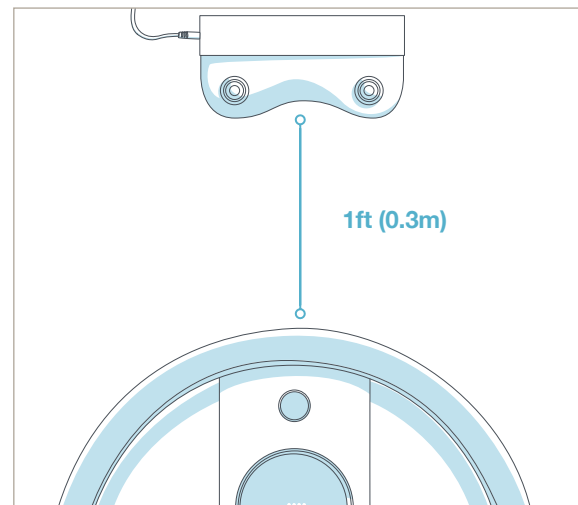

The far left and right battery bars represent the station's sensors. If either one of them fails to light up, then clean the window in front of Junior's charging station.

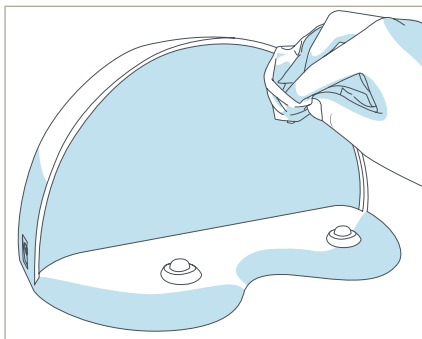

The two middle battery bars represent Junior's sensors. If they fail to light up, wipe clean Junior's cover receiver and the small sensor on the center of his bumper.

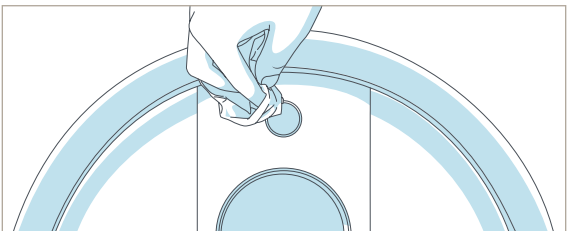

If all four bars light up correctly, you may move on to the next step of the checkup test.

### Step Five: Display Screen

Press the GO! button on Junior's cover once more. Each icon on Junior's screen will light up in a repeating rotation.

Once the cycle has finished, you may move on to the next step of the checkup test.

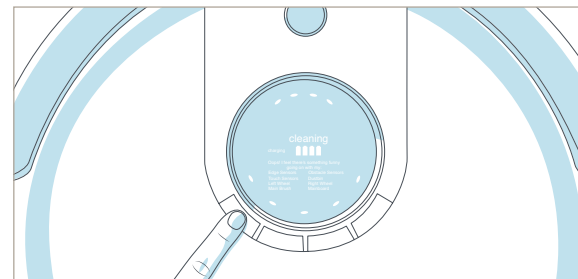

### Step Six: Brush and Suction Power

Press the WAFFLE button on Junior's cover.

Both the side brush and the main brush should start rotating and you should feel air flowing from the back of the dustbin.

If Junior's main brush is having difficulty moving, Junior will let you know by indicating on his screen that there is "something funny going on" with his main brush.

If Junior's vacuum motor is behaving oddly or if his dustbin has been removed, he will indicate that there's "something funny going on" with his dustbin.

Move on to the next step of the checkup test if all parts are working properly.

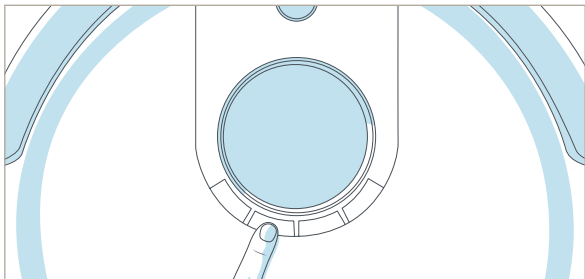

### Step Seven: Wheels

Lift Junior off the floor to keep him from running away! Next, press the MUTE button and his wheels should drive forward.

Press the MUTE button once more. Junior's wheels should drive backwards.

If Junior is having difficulty rotating either one of his wheels, he will indicate on his screen that there is "something funny going on" with either one of them.

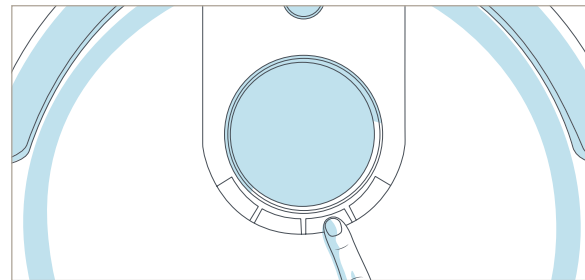

If Junior completes the checkup test without any issues, then his internal parts are working properly! Contact [support@bobsweep.com](mailto:support@bobsweep.com) or scan this QR code if you have any questions, as our doctors at the bObsweep hospital are always ready to help!

## Warranty Information

Every Junior purchased from an authorized seller and used anywhere in the world includes a 1-year limited warranty, 5 years of subsidized visits to the bObsweep hospital, and a lifetime of customer support. The warranty covers the battery and all labor and parts, except consumables like brushes and filters. Postal charges are not covered by the warranty.

Additional coverage plans are available for purchase at [bobsweep.com/coverageplan](https://bobsweep.com/coverageplan).

Even after Junior's 1-year warranty is over, replacement parts and visits to the bObsweep hospital are subsidized between 25% – 50% for 5 years from the date he was first purchased.

To activate Junior's warranty, keep your original receipt and register him online at [bobsweep.com/warranties](https://bobsweep.com/warranties).



## Junior's Cleaning Behavior

Junior's cleaning pattern may look quite different from the way a human would clean: he may spin in a gradually widening circle, follow along walls, or zigzag across a small area. Sometimes he may seem to be ignoring some spaces or spending too much time on others — but don't worry! Junior will efficiently clean your home within the course of a full cycle — just check his dustbin for the evidence!

It is best to let Junior work in his own way, even if his movements appear odd. Moving him around, manipulating his movements, or picking him up may confuse him and disrupt his cycle.

If you wish to control Junior's movements manually, you may use the navigational buttons on his remote. If your rooms are divided by higher ledges than Junior is able to climb, you may block off the area using blOck's digital barriers (available separately).

## Junior's Challenges

### Unique Furniture

Junior is designed to maneuver around furniture of most shapes and sizes, but certain configurations may confuse him temporarily. Junior may sometimes find it difficult to clean under chairs with narrow legs, or furniture that is too low for his bumper sensors to detect. Specialty furniture, such as desk chairs with wheels or stools with circular bases, may also confuse him for a moment — but don't worry, Junior usually finds his way around with time.

### Edge Sensors

Junior uses infrared light to detect edges and stairs; because dark-colored carpet absorbs most light, it may seem like an edge to Junior's sensors. If Junior indicates on his screen that there is "something funny going on" with his edge sensors, you may need to temporarily deactivate them. To do so, simply hold down the CHECKUP button on Junior's cover until the 4 bars at the top of the screen flash 7 times and remain lit on his screen [see page 43]. Just remember that while Junior's sensors are deactivated, he will not be able to detect edges or stairs!

### Main Brush

Junior's main brush, which is designed to reach deep into carpet, may also have trouble turning on rugs with long fibers or fringes. You may tuck fringes under rugs or remove Junior's main brush and see how he performs without it.

## Inclines

Sometimes Junior will attempt to drive up angled surfaces and get stuck for a few minutes before deciding to clean somewhere else. This is because Junior wants to cover every spot in your home and will try his hardest to overcome any obstacle!

As long as Junior does not indicate on his screen that there is a problem, let him find his own way around your home and continue cleaning. Take note of the areas Junior finds the most challenging, and if possible spread or adjust some of your furniture accordingly.

## The Solution: bLOck

If Junior finds a part of your home challenging to clean, use bLOck (available separately) to keep him away. bLOck emits a digital barrier that Junior won't cross.

## FAQs

### 1. Where can I find Junior's how-to videos?

Junior's "training" videos can be found at Junior's Owners' Corner: [owners.bobsweep.com](https://owners.bobsweep.com).

### 2. How long should Junior's battery last?

The exact time depends on the type of surface Junior is cleaning as well as the age of the battery. Generally, the smoother the surface (hardwood or tile, for example), the longer the battery will last. When fully charged, a brand new Junior usually cleans for just over an hour.

### 3. How do I know that my Junior has fully charged and is ready to clean?

When Junior charges using the adapter or charging station, the battery bars on his display screen flash and the word "Charging" lights up. When Junior has fully charged, the battery bars remain still and the word "Charging" disappears.

### 4. How often should I empty the dustbin?

Junior's dustbin has a 1 L capacity — three times larger than most robotic vacuum cleaners on the market today! This means you may not need to empty the dustbin immediately after every cleaning. Depending on the size of the room and the amount of particles piled up, Junior can complete approximately six cleaning cycles before he fills his dustbin. Simply remove the dustbin and check to see if emptying is necessary.

### 5. How often should I clean Junior's brushes?

Junior's brushes do a lot of the work picking up hair and debris, so it is recommended that you clean the main and side brushes weekly if you are using Junior regularly. To thoroughly clean the brushes, remove them using a flat head screwdriver. Remember to clean the notches in Junior's interior that hold his brushes in place. This ensures the brushes stay in peak condition for a long time.

6. My Junior won't turn on no matter what I do.

If Junior does not start after flipping his power switch ON, his battery has likely drained too low to operate. To recharge him, place him directly onto his charging station with the metal plates on his underside lined up with the nodes on his station. Let Junior recharge fully before asking him to clean again. When Junior charges, the battery bars on his display screen flash and the word "Charging" lights up. When Junior has fully charged, the battery bars remain still and the word "Charging" disappears.

7. Why is Junior beeping?

Junior beeps once every 2 minutes when he is on standby mode. To conserve battery, turn his power switch OFF. You may also mute Junior's beeping by pressing the MUTE button on his cover or remote.

Junior also beeps when he encounters a problem cleaning and needs assistance. In this instance, he will also identify the source of the issue directly on his screen. Consult the Troubleshooting section of this manual [page 47] to see what to do when Junior is having trouble with one of his parts.

8. Junior is having trouble finding his charging station. Where is the best place to put his station?

Junior will find his station more easily if it you place it in a central location with plenty of space around it, so that he may detect it from afar. In order for Junior to dock properly, be sure to place the charging station against a wall on a flat, level surface.

11. Junior is telling me there's "something funny going on" with one of his parts. How can I fix this?

Junior notifies you directly on his screen the specific reason his work has been interrupted. This self-scanning feature allows you to quickly identify the source of the problem. If "something funny" is going on with one of Junior's parts, the problem can usually be solved with simple procedures. Consult the Troubleshooting section of this manual [page 47] to see the most probable solutions.

9. I am having problems removing Junior's brush.

If the main or side brush is difficult to remove, it is likely because hair, string, and/or other debris have been caught in it and are clogging the areas where it attaches to Junior. It is best to clean Junior's brushes about once a week to prevent buildup. You can use scissors to cut away hair wrapped around the brushes until you are able to remove them. You may need to gently pull the main brush up or down to reach the corners, but do not force the brush out as this can damage it.

10. Junior gets stuck under my furniture or travels over wires that tangle up his brush. How can I stop him from going into these areas?

If Junior maneuvers under a piece of furniture and there is only one open entrance, he may need a few minutes to figure out how to exit on his own. You will not need to assist him when this happens, unless Junior stops cleaning completely and starts beeping.

If you would like Junior to avoid a certain area, such as an area with lots of wires, you may use bIock (available separately) to create a digital barrier.

12. What is the best way to clean Junior's wheels?

Use the cleaning tool or compressed air to clear the creases of the wheels. For a more thorough clean, wipe the sides and bottoms of the wheels as they spin during the checkup test [see page 52].

13. My Junior just stopped cleaning and his screen turned off. What do I do next?

Like other electronic devices with a CPU (computers, smartphones, etc.), Junior may experience a momentary halt in his operating system. You can usually get Junior back to work by simply turning his power switch OFF and ON again. If this does not solve the issue, perform a mainboard reset. You can reset Junior's mainboard by flipping his power switch OFF and plugging the charging adapter directly into the inlet on his side. Leave him to charge for at least 2 hours to fully refresh his system.

14. I have a question and need to contact Junior's support team. How do I do that?

Our devoted team is always eager to help you! You can reach us by phone or e-mail. Call us toll free at [1-888-549-8847](tel:1-888-549-8847) for support in the United States and Canada, or e-mail us at [support@bobsweep.com](mailto:support@bobsweep.com). Our goal is to get back to you within a day.

To watch Junior's how-to, repair, and troubleshooting videos; order parts; and connect with your extended bObsweep family members, visit [owners.bobsweep.com](http://owners.bobsweep.com).

# End User License Agreement for bObsweep Software and Junior

IMPORTANT - READ BEFORE USING. Do not use the robot ("Junior") accompanying this license agreement ("Agreement") until you have carefully read and agreed to the following terms and conditions.

By using the Junior, you agree to the terms of this End User License Agreement ("EULA") and any amendment or addenda accompanying this Agreement. If you do not agree to the terms of this EULA, you may not use the Junior. The Junior contains an electronic and software interface that allows you to control or modify its behavior, and remotely monitor its sensors.

THIS IS A LEGAL AGREEMENT. BY ACCESSING AND USING THE PRODUCT AND PRODUCT SOFTWARE, YOU ARE ACCEPTING AND AGREEING TO THIS EULA ON BEHALF OF YOURSELF OR THE ENTITY YOU REPRESENT IN CONNECTION WITH THE ACCESS. YOU REPRESENT AND WARRANT THAT YOU HAVE THE RIGHT, AUTHORITY, AND CAPACITY TO ACCEPT AND AGREE TO THIS EULA ON BEHALF OF YOURSELF OR THE ENTITY YOU REPRESENT. YOU REPRESENT THAT YOU ARE OF SUFFICIENT LEGAL AGE IN YOUR JURISDICTION OR RESIDENCE TO USE OR ACCESS THE PRODUCT SOFTWARE AND TO ENTER INTO THIS EULA. IF YOU DO NOT AGREE WITH ANY OF THE PROVISIONS OF THESE TERMS, YOU SHOULD CEASE USING THE PRODUCT AND PRODUCT SOFTWARE. Terms and Conditions

LICENSE: Subject to all of the terms of this Agreement, Bobsweep Inc. ("Bobsweep") grants to you one (1) revocable, royalty-free, personal, non-exclusive, nontransferable, non-assignable, non-commercial intellectual property license to use the Bobsweep software contained on the Junior, including the protocol for communicating with the Bobsweep software contained on the Junior ("Bobsweep Software"), to use the Junior.

NONCOMMERCIAL LICENSE: You may use the Bobsweep Software and the Junior only for personal, noncommercial, educational, and research purposes. The Bobsweep Software and the Junior may not be used for any other purpose, whether "for prot" or "not for prot." Any work performed or produced using the Junior, including Your Software, cannot be performed or produced for the benefit of other parties for a fee, compensation, or any other reimbursement or remuneration. A separate license is required for each additional use and/or individual user in all other cases. If you are an entity, Junior grants you the right to designate one individual within your organization to have the sole right to use the Bobsweep Software and the Junior in the manner provided above. RESTRICTIONS: You agree not to: (i) use or copy the Bobsweep Software or the Junior except as provided in this Agreement; (ii) rent or lease the Bobsweep Software or the Junior to any third party; (iii) assign this Agreement or transfer the Bobsweep Software or the Junior except as provided in this Agreement; (iv) modify, adapt, or translate the Bobsweep Software or the Junior in whole or in part except as expressly provided in this Agreement; (v) reverse engineer, reverse compile, or disassemble the Bobsweep Software or the Junior; or (vi) distribute, sublicense or transfer the source code form of Your Software and derivatives thereof to any third party except as provided in this Agreement. YOUR SOFTWARE : Use and distribution of any software that you create for your Junior ("Your Software") is also subject to the following limitations: You (i) shall be solely responsible for any update or support obligation or other liability which may arise from your use or distribution, (ii) shall not make any statement that Your Software is "certified," or that its performance is guaranteed, by Bobsweep, (iii) shall not use Bobsweep or Junior's name(s) or trademark(s), (iv) shall prohibit disassembly and reverse engineering of the Bobsweep Software and the Junior, (v) shall not publish reviews of Bobsweep products designated as beta without written permission from Bobsweep, and (vi) shall indemnify, hold harmless, and defend Bobsweep and its suppliers from and against any claims or lawsuits, including attorney's fees, that arise or result from Your Software, including your use and your distribution. TITLE: Title to the Bobsweep Software remains with Bobsweep or its suppliers. The Bobsweep Software is licensed, not sold. Except as expressly provided herein, Bobsweep does not grant any express or implied right to you under Bobsweep patents, copyrights, trademarks, or trade secret information. You will not remove any copyright or patent notice from the Bobsweep Software or the Junior. ONE-TIME TRANSFER: The initial user of the Bobsweep Software and the Junior may make a one-time permanent transfer of this Agreement, the Bobsweep Software, and the Junior to another end user, provided that the initial user retains no copies of the Bobsweep Software and the Junior. This transfer must include the Bobsweep Software, the Junior, and all of the materials accompanying the Junior (including all component parts and printed materials, any upgrades, and this End User License Agreement document). The transfer may not be an indirect transfer, such as a consignment. Prior to the transfer, the end user receiving the Bobsweep Software and the Junior must agree to all the terms of this Agreement. NO WARRANTY AND LIMITED REPLACEMENT: EXCEPT AS STATED IN THE LIMITED WARRANTY TO THE ORIGINAL PURCHASER, THE BOBSWEEP SOFTWARE AND THE JUNIOR ARE PROVIDED "AS IS" WITH NO WARRANTIES, EXPRESS OR IMPLIED, INCLUDING BUT NOT LIMITED TO ANY IMPLIED WARRANTY OF MERCHANTABILITY, FITNESS FOR A PARTICULAR PURPOSE, NON-INFRINGEMENT OF INTELLECTUAL PROPERTY RIGHTS, OR ANY WARRANTY OTHERWISE ARISING OUT OF ANY PROPOSAL, SPECIFICATION, OR SAMPLE. NO ORAL OR WRITTEN INFORMATION OR ADVICE GIVEN BY BOBSWEEP OR ITS AGENTS SHALL CREATE A WARRANTY. If the Bobsweep Software or the Junior is found to be defective in material or workmanship under normal use for a period of one (1) year from the date of receipt, Bobsweep's entire liability and your exclusive remedy shall be the replacement of the Bobsweep Software or the Junior. This offer is void if the defect results from accident, abuse

misapplication, or software that you developed for your Junior. Any updates or supplements to the Bobsweep Software or the Junior provided to be defective in material or workmanship under normal use for a period of one (1) year from the date of receipt, Bobsweep's entire liability and your exclusive remedy shall be the replacement of the Bobsweep Software or the Junior. This offer is void if the defect results from accident, abuse, misapplication, or software that you developed for your Junior. Any updates or supplements to the Bobsweep Software or the Junior provided to you after the expiration of the one (1) year period are not covered by any warranty or condition, express, implied or statutory. SOME JURISDICTIONS DO NOT ALLOW THE EXCLUSION OF IMPLIED WARRANTIES, SO THE ABOVE EXCLUSION MAY NOT APPLY TO YOU. LIMITATION OF LIABILITY: THE ABOVE REPLACEMENT PROVISION IS THE ONLY WARRANTY OF ANY KIND. BOBSWEEP OFFERS NO OTHER WARRANTY EITHER EXPRESS OR IMPLIED INCLUDING THOSE OF MERCHANTABILITY, NON-INFRINGEMENT OF THIRD-PARTY INTELLECTUAL PROPERTY OR FITNESS FOR A PARTICULAR PURPOSE. NEITHER BOBSWEEP NOR ITS SUPPLIERS SHALL BE LIABLE FOR ANY DAMAGES WHATSOEVER (INCLUDING, WITHOUT LIMITATION, VICARIOUS LIABILITY, CONSEQUENTIAL DAMAGES, INCIDENTAL DAMAGES, DAMAGES FOR LOSS OF BUSINESS PROFITS, BUSINESS INTERRUPTION, LOSS OF BUSINESS INFORMATION, OR OTHER LOSS) ARISING OUT OF THE USE OF OR INABILITY TO USE THE BOBSWEEP SOFTWARE, THE JUNIOR, OR SOFTWARE THAT YOU DEVELOPED FOR YOUR JUNIOR, EVEN IF BOBSWEEP HAS BEEN ADVISED OF THE POSSIBILITY OF SUCH DAMAGES. BECAUSE SOME JURISDICTIONS PROHIBIT THE EXCLUSION OR LIMITATION OF LIABILITY FOR CONSEQUENTIAL OR INCIDENTAL DAMAGES, THE ABOVE LIMITATION MAY NOT APPLY TO YOU. UNAUTHORIZED USE: THE BOBSWEEP SOFTWARE AND THE JUNIOR ARE NOT DESIGNED, INTENDED, OR AUTHORIZED FOR USE IN ANY AERONAUTICAL, NUCLEAR, MEDICAL, LIFE SAVING OR LIFE SUSTAINING SYSTEMS, OR FOR ANY OTHER APPLICATION IN WHICH THE USE OF THE BOBSWEEP SOFTWARE OR THE JUNIOR COULD CREATE A SITUATION WHERE PERSONAL INJURY OR DEATH MAY OCCUR. Should you use the Bobsweep Software or Junior for any such unintended or unauthorized use, you shall indemnify and hold harmless Bobsweep and its officers, subsidiaries and affiliates against all claims, costs, damages, and expenses, and reasonable attorney fees arising out of, directly or indirectly, any claim of product liability, personal injury or death associated with such unintended or unauthorized use, even if such claim alleges that Bobsweep was negligent regarding the design or manufacture of the Bobsweep Software, the Junior, or any part or portion thereof. USER SUBMISSIONS: You agree that any material, information or other communication, including all data, images, sounds, text, and other things embodied therein, that you transmit or post to a Bobsweep website or provide to Bobsweep ("Communications") will be considered non-confidential. Bobsweep will have no confidentiality obligations with respect to the Communications. You agree that Bobsweep and its designees will be free to copy, modify, create derivative works, publicly display, disclose, distribute, license and sublicense through multiple tiers of distribution and licensees, incorporate and otherwise use the communications, including derivative works thereof, for any and all commercial or non-commercial purposes without the payment of any royalty to you, and that such license will survive the termination of this Agreement.

TERMINATION: This Agreement becomes effective on the date you accept this Agreement and will continue until terminated as provided for in this Agreement. You may terminate this Agreement voluntarily at any time. Bobsweep may terminate this Agreement at any time if you are in breach of any of its terms and conditions, and may refuse to license the Bobsweep Software or the Junior to you after termination. Upon termination by either party, you will immediately return to Bobsweep or destroy the Bobsweep Software and the Junior and all your copies thereof. Articles 5 and 7 through 17 of this Agreement shall survive such termination. U.S. GOVERNMENT RESTRICTED RIGHTS: The Bobsweep Software and the Junior are provided with "RESTRICTED RIGHTS." Use, duplication or disclosure by the Government is subject to restrictions set forth in FAR52.227-14 and DFAR252.227-7013 et seq. or its successor. Use of the Bobsweep Software or the Junior by the Government constitutes acknowledgment of Bobsweep's rights in them. NO EXPORT: You may not export the Bobsweep Software or the Junior in violation of applicable export laws. INTERPRETATION: The provisions of this Agreement are severable. If any provision of this Agreement is held to be unenforceable, such provision shall be reformed only to the extent necessary to make it enforceable. Any law or regulation which provides that the language of a contract shall be construed against the drafter shall not apply to this Agreement. INTEGRATION: This Agreement represents the complete agreement concerning the subject matter hereof, and any and all understandings, conversations and communications, proposals, and counterproposals, oral and written (including any draft of this Agreement) are merged into and superseded by this Agreement and shall be of no force or effect, except as expressly provided herein. No such understandings, conversations, communications, proposals, counterproposals or drafts shall be referred to in any proceeding concerning this Agreement. Further, no understanding contained in this Agreement shall be modified, altered or amended, except by a writing signed by the party against whom enforcement is sought. ARBITRATION: All disputes relating to this Agreement (excepting any dispute relating to intellectual property rights) shall be subject to final and binding arbitration, with the losing party paying all costs of arbitration. Any arbitration relating to this Agreement shall be held in California, under the auspices of an arbitrator selected by Bobsweep. Any litigation relating to this Agreement shall be subject to exclusive venue and jurisdiction in the federal and state courts of California, with the losing party responsible for costs, including without limitation, court costs and reasonable attorneys fees and expenses. APPLICABLE LAWS: Any claim arising under or relating to this Agreement shall be governed by the internal substantive laws of the Commonwealth of California, without regard to its principles of conflict of laws. The application of the United Nations Convention on Contracts for the International Sale of Goods is expressly excluded.



## Free Manuals Download Website

<http://myh66.com>

<http://usermanuals.us>

<http://www.somanuals.com>

<http://www.4manuals.cc>

<http://www.manual-lib.com>

<http://www.404manual.com>

<http://www.luxmanual.com>

<http://aubethermostatmanual.com>

Golf course search by state

<http://golfingnear.com>

Email search by domain

<http://emailbydomain.com>

Auto manuals search

<http://auto.somanuals.com>

TV manuals search

<http://tv.somanuals.com>