

INDOOR/OUTDOOR PRODUCTS
KEROSENE PORTABLE
FORCED AIR HEATERS
“USER’S MANUAL AND
OPERATING INSTRUCTIONS”

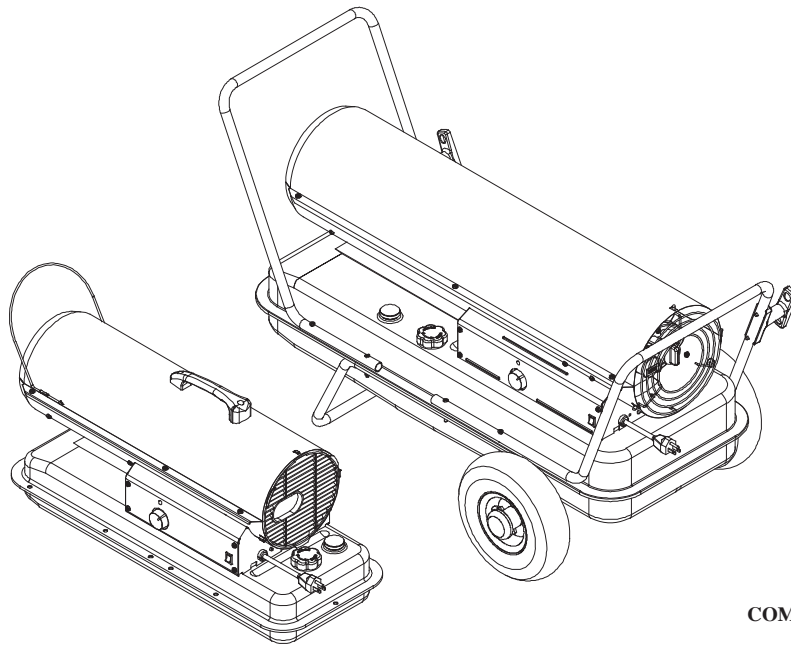

COMPLIES WITH UL733 AND
ANSI A10.10-1990
CAN/CSA/B140.0-03 AND CSA
B140.8-1967

Dyna-Glo® Delux

MODEL : RMC-KFA45DGD, RMC-KFA75TDGD, RMC-KFA125TDGD
RMC-KFA170TDGD, RMC-KFA210TDGD, RMC-KFA210TDGD-01

Before the first use of this heater, please read this USER’S MANUAL very carefully. This USER’S MANUAL has been designed to instruct you as to the proper manner in which to assemble, maintain, store, and most importantly, how to operate the heater in a safe and efficient manner. Please keep this manual for future reference.

CONSUMER : Retain this manual for future reference.

Questions, problems, missing parts? Before returning to your retailer, call our customer service department at 877-447-4768 8:30 a.m. - 4:30 pm CST, Monday - Friday.
or email us at customerservice@ghpgroupinc.com

**NEVER LEAVE THE HEATER
UNATTENDED WHILE BURNING!**

⚠ DANGER: IMPROPER USE OF THIS HEATER CAN RESULT IN SERIOUS INJURY OR DEATH FROM BURNS, FIRE, EXPLOSION, ELECTRICAL SHOCK AND/OR CARBON MONOXIDE POISONING.

⚠ WARNINGS:

1. RISK OF INDOOR AIR POLLUTION!

- Use this heater only in well ventilated areas. Provide at least a three-square foot (2,800 sq. cm.) opening of fresh outside air for each 100,000 BTU/hr. of heater rating.
- People with breathing problems should consult a physician before using the heater.
- **Carbon monoxide poisoning:** Early signs of carbon monoxide poisoning resemble the flu, with headaches, dizziness and/or nausea. If you have these signs, the heater may not be working properly.
Get fresh air at once! Have the heater serviced. Some people are more affected by carbon monoxide than others. These include pregnant women, persons with heart or lung disease or anemia, those under the influence of alcohol, or those at high altitudes.
- Never use this heater in living or sleeping areas.

2. RISK OF BURNS/FIRE/EXPLOSION!

- NEVER use any fuel other than 1-K kerosene, #1 diesel/fuel oil in this heater.
- NEVER use fuel such as gasoline, benzene, paint thinners or other oil compounds in this heater.
(RISK OF FIRE OR EXPLOSION)
- NEVER use this heater where flammable vapors may be present.
- NEVER refill the heaters fuel tank while heater is operating or is still hot.

⚠ CAUTION : Hot while in operation. Do not touch. Keep children, clothing and combustibles away from heater.

Minimum Clearances: Outlet: 8 feet (250cm) / Sides, top and rear: 4 feet (125cm)

- NEVER block air inlet (rear) or air outlet (front) of heater.
- NEVER use duct work in front or behind of heater.
- NEVER move, handle, service a hot, operating or plugged in heater.
- NEVER transport heater with fuel in it's tank.
- When used with an optional thermostat or if equipped with a thermostat heater may start at any time.
- ALWAYS locate heater on a stable and level surface.
- ALWAYS keep children and animals away from heater.
- Bulk fuel storage should be a minimum of 25 ft. from heaters, torches, portable generators or other sources of ignition.
All fuel storage should be in accordance with federal, state or local authorities having jurisdiction.

3. RISK OF ELECTRIC SHOCK!

- Use only the electrical power (voltage and frequency) specified on the model plate of the heater.
- Use only a three-prong, grounded outlet and extension cord.
- ALWAYS install the heater so that it is not directly exposed to water spray, rain, dripping water or wind.
- ALWAYS unplug the heater when not in use.

PROPOSITION 65 WARNING: Fuels used in gas, wood-burning or oil fired appliances, and the products of combustion of such fuels, contain chemicals known to the State of California to cause cancer, birth defects and other reproductive harm.

MASSACHUSETTS RESIDENTS: Massachusetts state law prohibits the use of this heater in any building which is used in whole or in part for human habitation. Use of this heating device in Massachusetts requires local fire dept. permit (M.E.L.C. 148, Section 10A.)

CANADIAN RESIDENTS: Use of this heater shall be in accordance with authorities having jurisdiction and CSA Standard B139.

NEW YORK CITY RESIDENTS: For use only at construction sites in accordance with applicable NYC codes under NYCFD certificate of approval # 5034 and 5037.

**NEVER LEAVE THE HEATER
UNATTENDED WHILE BURNING!**

CONTENTS OF USER'S MANUAL

<u>ITEM</u>	<u>PAGE #</u>
PRECAUTIONS - SAFETY GUIDE	1
1. INTRODUCTION	2
2. FEATURES	2
3. UNPACKING AND ASSEMBLY	4
4. KEROSENE (1-K OR NO. 1 FUEL OIL)	7
5. OVERVIEW OF HEATER DESIGN	8
6. FUELING YOUR HEATER	9
7. OPERATION	9
8. LONG TERM STORAGE OF YOUR HEATER	10
9. MAINTENANCE	11
10. REPLACING FUSE	15
11. TROUBLE SHOOTING GUIDE	16
12. WIRING DIAGRAM	17
13. SPECIFICATIONS	18
14. EXPLODED PARTS DRAWING	19
15. PARTS LIST	21

1. INTRODUCTION

Please read this USER'S MANUAL carefully. It will show you how to assemble, maintain, and operate the heater safely and efficiently to obtain full benefits from its many built-in features.

2. FEATURES

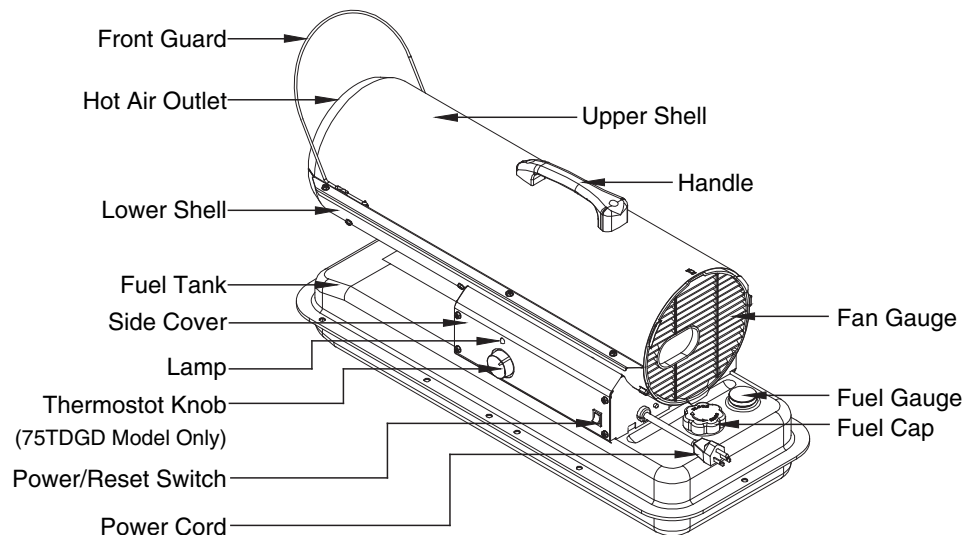

Figure 1. RMC-KFA45DGD/75TDGD MODELS

**NEVER LEAVE THE HEATER
UNATTENDED WHILE BURNING!**

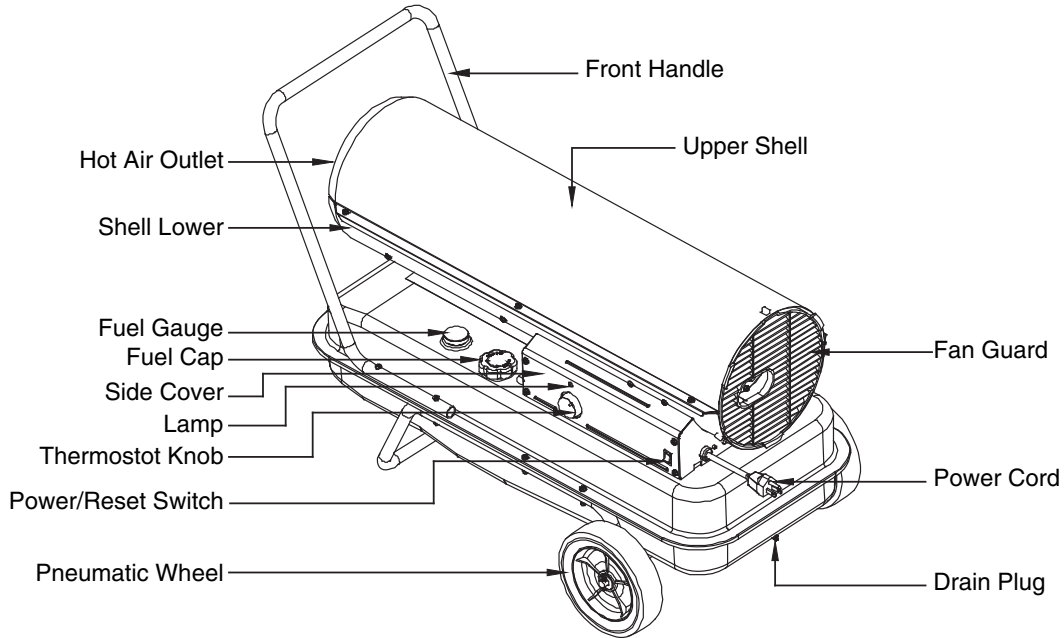

Figure 2. RMC-KFA125TDGD MODEL

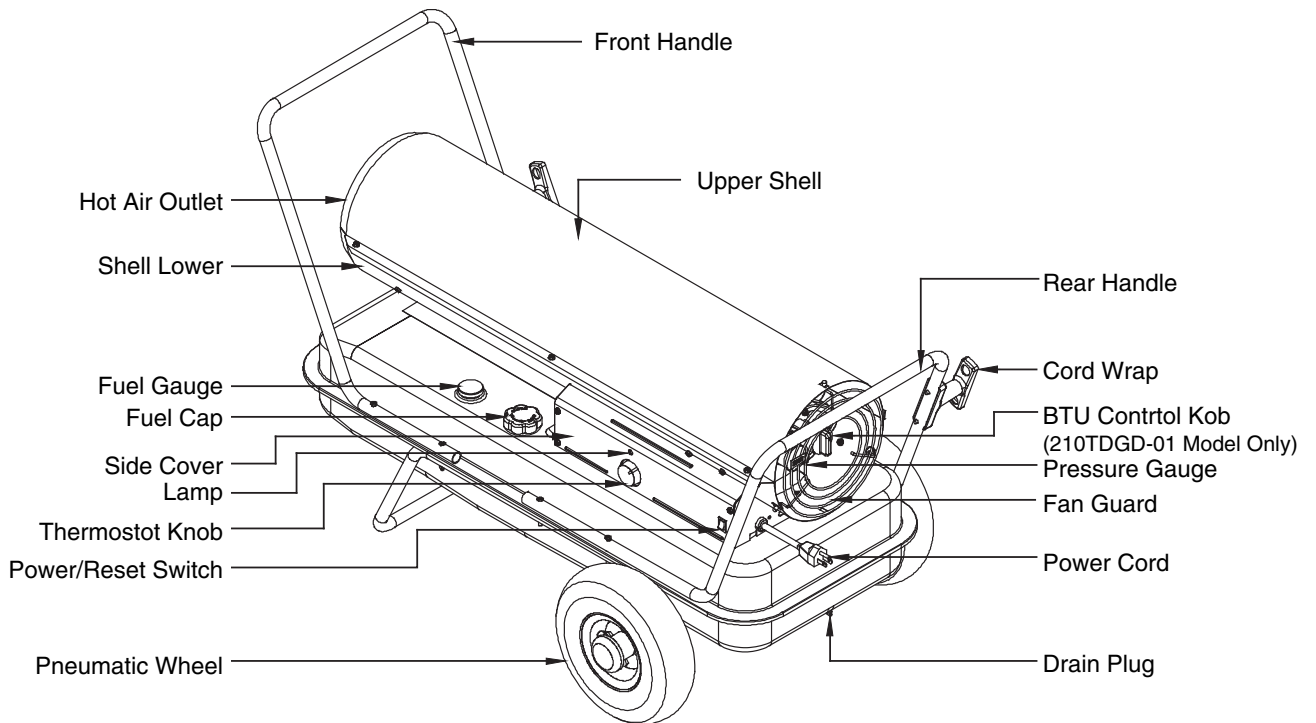

Figure 3. RMC-KFA170/210TDGD/210TDGD-01 MODELS

**NEVER LEAVE THE HEATER
UNATTENDED WHILE BURNING!**

3. UNPACKING AND ASSEMBLY

1. REMOVE THE HEATER AND ALL PACKING MATERIALS FROM THE BOX. (Fig. 4 and 5)

NOTE : Save the shipping carton and packing materials for future storage.

	RMC-KFA45/75TDGD	RMC-KFA125TDGD	RMC-KFA170/210TDGD	RMC-KFA210TDGD-01
Wheel Support Frame	No	Yes	Yes	Yes
Axle	No	Yes	Yes	Yes
Front Handle	No	Yes	Yes	Yes
Rear Handle	No	No	Yes	Yes
Handle	Yes	No	No	No
Cord Wrap	No	Yes	Yes	Yes
BTU Control Valve	No	No	No	Yes
Hardware kit : HW-KFA1000	Yes	No	No	No
Hardware kit : HW-KFA1010	No	Yes	No	No
Hardware kit : HW-KFA1012	No	No	Yes	Yes

Figure 4. RMC-KFA45DGD/75TDGD MODELS

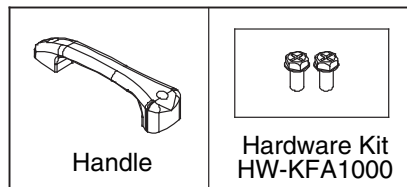
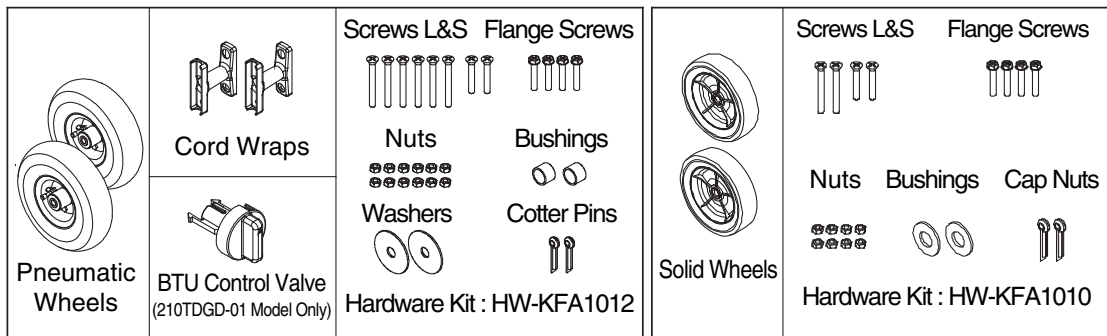
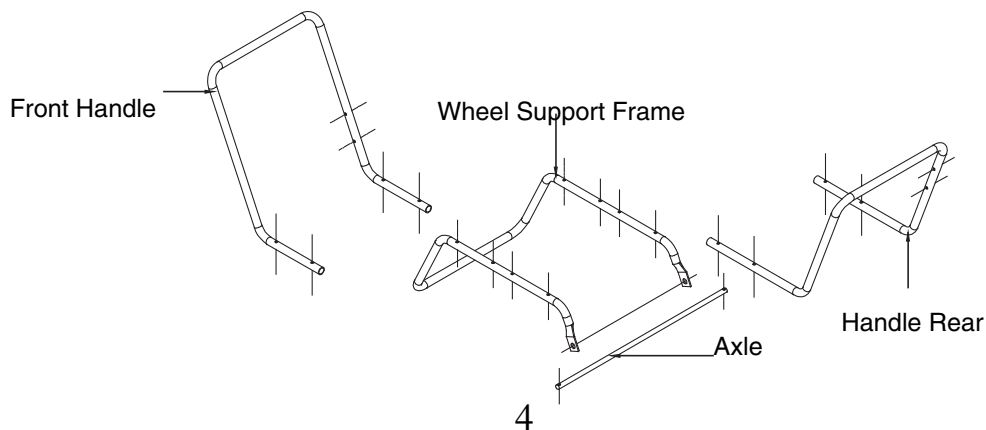

Figure 5. RMC-KFA125/170/210TDGD MODELS



RMC-KFA170/210TDGD/210TDGD-01 MODELS

RMC-KFA125TDGD MODEL



**NEVER LEAVE THE HEATER
UNATTENDED WHILE BURNING!**

2. ASSEMBLY

A. For RMC-KFA45DGD/75TDGD Models only

Tools Required

- Medium Phillips Screwdriver.
Assembling Handle

1. Lift front guard for arrow direction and make sure that guard's wedged portion fits into the slit hole on the upper housing.
2. Align the holes in the upper housing with two mounting holes on the handle as shown in Figure 6.
3. Secure handel with Screws with provided.

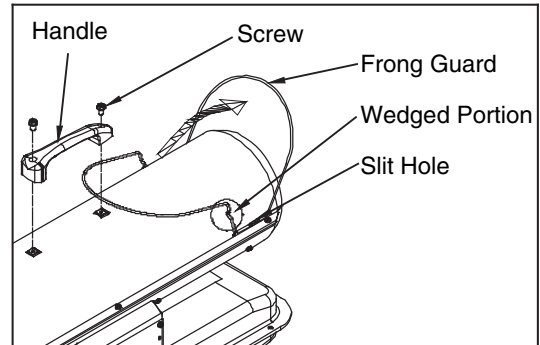

Figure 6. Assembling Handle

B. For RMC-KFA125TDGD Model only

Tools Required

- Medium Phillips Screwdriver
- 5/16"(M5) open or Adjustable Wrench, Use US(Inch) Screws Nuts
- Long Nose Pliers

1. Slide axle through wheel support frame. Install wheels on axle.
NOTE : When installing wheels, point extended hub of wheels toward wheel support frame. (See Figure 7)
2. Place Flat washers and cotter pin on axle ends and bend split pins with long nose pliers to secure.
3. Place heater on wheel support frame. Make sure air inlet end (rear) of heater is over wheels. Align the holes on fuel tank flange with holes on wheel support frame.
4. Position the handle on top of fuel tank flange. Insert screws through handles, fuel tank flange, and wheel support frames as shown in Figure 7 and attach nut finger tight after each screw is inserted.
5. After all screws are inserted, tighten nuts firmly.

⚠ CAUTION : DO NOT OPERATE heater without support frame assembled to tank.

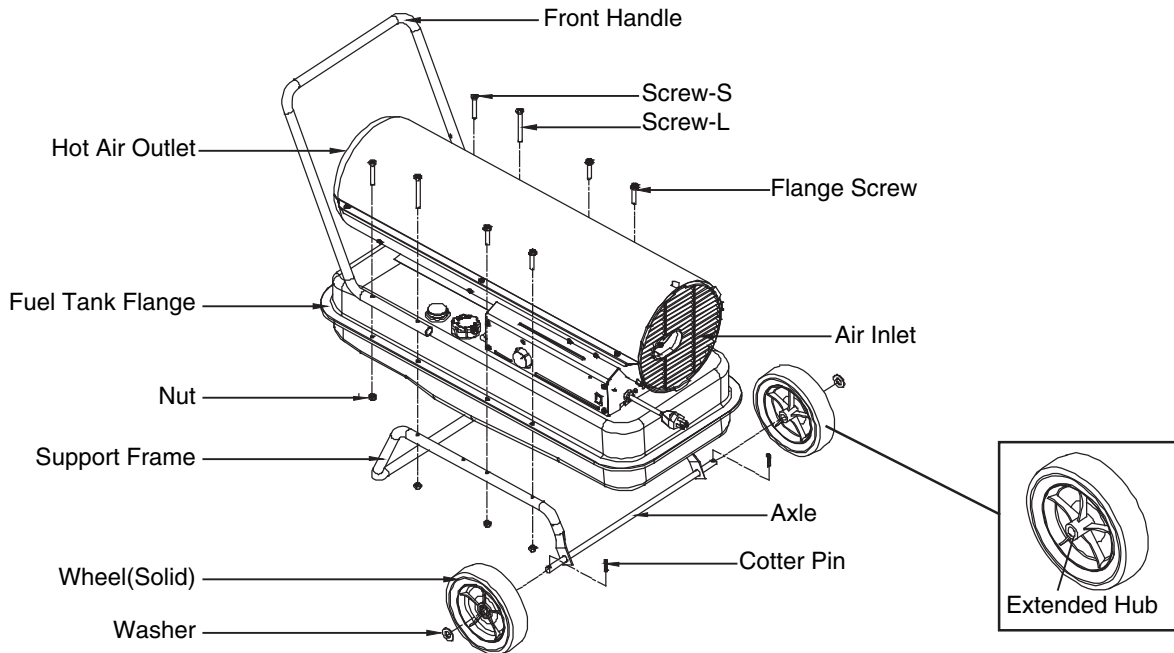

Figure 7. Assembling Handle and Wheel

**NEVER LEAVE THE HEATER
UNATTENDED WHILE BURNING!**

C. For RMC-KFA170/210TDGD/210TDGD-01 Models only

Tools Required

- Medium Phillips Screwdriver.
- M5 open, or adjustable wrench
- Long nose pliers.

1. Slide axle through wheel support frame. Install wheel bushings and wheels on axle.

NOTE : When installing wheels, tube valve should face out from support frame (Figure 8).

2. Place flat washers and cotter pin on axle ends and bend cotter pins with long nose pliers to secure.

3. Place wheel cap on flat washers and put wheel cap in flat washers end.

4. Place heater on wheel support frame.

Make sure air inlet end(rear) of heater is over wheels. Align the holes on fuel tank flange. Insert screws through handles(front and rear), fuel tank flange, and wheel support frame as shown in Figure 8 and attach nut finger tight after each screw is inserted.

5. After all screws are inserted, tighten nuts firmly.

6. Align the hole on the handle(front and rear) with the mounting hole on the cord wrap.

7. Insert screws through cord wrap, handles as shown in figure 8 and attach nut finger tight after each screw is inserted.

8. After all screws are inserted, tighten nuts firmly.

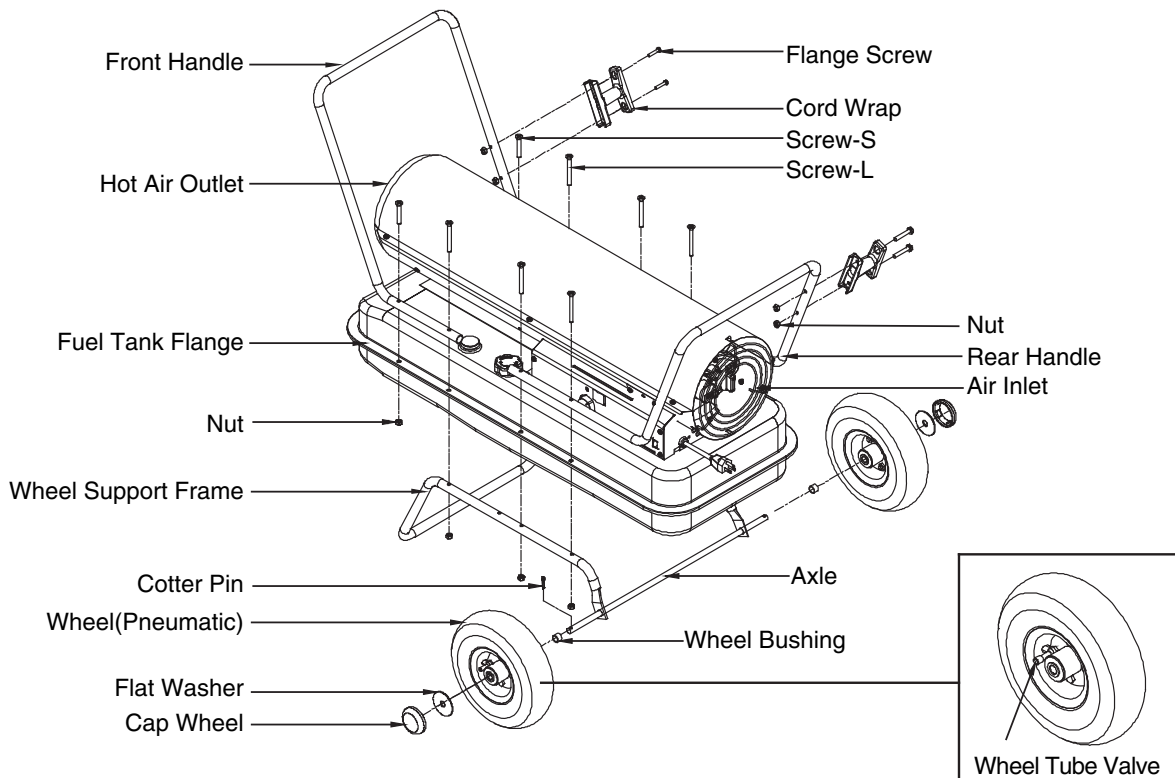

Figure 8. Assembling Handle, Wheel and Cord wrap

⚠ CAUTION : DO NOT OPERATE heater without support frame assembled to tank.

NOTE : Heater should be inspected before each use, and at least annually by a qualified service person.

**NEVER LEAVE THE HEATER
UNATTENDED WHILE BURNING!**

D. For RMC-KFA210DGP-01 Model Only.
Assembling BTU Control Valve

1. Align slit hole on body of Valve with Tab on the End Filter Cover as shown in Figure 9.
2. Insert hooked leg of valve fully into slot of End Filter Cover so that hooked leg is completely locked to Slot.

NOTE : When install valve to End Filter Cover, If Valve is assembled for incorrect knob direction, Hooked leg is not completely locked to slot.

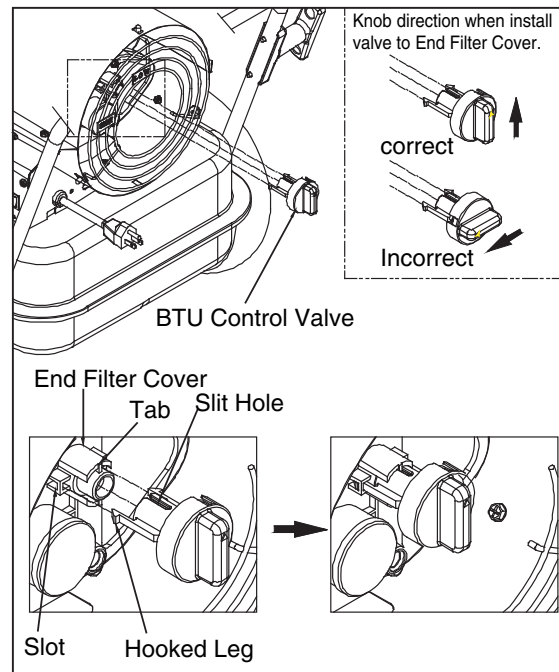

**Figure 9. Assembling BTU Control Valve
(RMC-KFA210TDGD-01 Model Only)**

4. KEROSENE (1-K)

For optimal performance of this heater, it is strongly suggested that 1-K kerosene be used. 1-K kerosene has been refined to virtually eliminate contaminants, such as sulphur. Which can cause a rotten egg odor during the operation of the heater. However, #1 diesel/fuel oil may also be used if 1-K kerosene is not available.

Be advised that these fuels do not burn as clean as 1-K kerosene, and care should be taken to provide more fresh air ventilation to accommodate any added contaminants that may be added to the heated space.

KEROSENE SHOULD ONLY BE STORED IN A BLUE CONTAINER THAT IS CLEARLY MARKED "KEROSENE". NEVER STORE KEROSENE IN A RED CONTAINER.

Red containers are associated with gasoline.

NEVER store kerosene in the living space. Kerosene should be stored in a well ventilated place outside the living area.

NEVER use any fuel other than 1-K kerosene (#1 fuel oil is an acceptable substitute.)

NEVER use fuel such as gasoline, benzene, alcohol, white gas, camp stove fuel, paint thinners, or other oil compounds in this heater. These are volatile fuels that can cause an explosion or uncontrolled flames.

NEVER store kerosene in direct sunlight or near a source of heat.

NEVER use kerosene that has been stored from one season to the next. Kerosene deteriorates over time.

"OLD KEROSENE" WILL NOT BURN PROPERLY IN THIS HEATER.

**NEVER LEAVE THE HEATER
UNATTENDED WHILE BURNING!**

5. OVERVIEW OF HEATERS DESIGN

Fuel System : This heater is equipped with an electric air pump that forces air through the air line connected to the fuel intake and then through a nozzle in the burner head. When the air passes in front of the fuel intake it causes fuel to rise from the tank and into the burner nozzle. This fuel and air mixture is then sprayed into the combustion chamber in a fine mist.

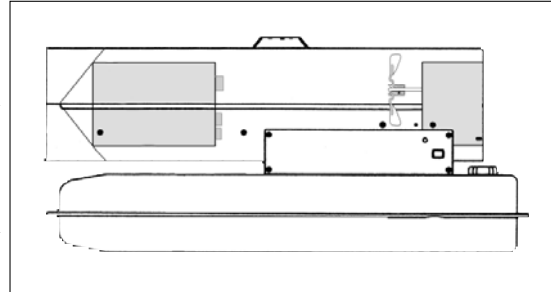

“Sure Fire Ignition” : The electronic ignitor sends voltage to a specially designed spark plug. The spark plug ignites the fuel and air mixture described above.

The Air System : The heavy duty motor turns a fan that forces air into and around the combustion chamber. Here the air is heated and then forced out the front of the heater.

The Safety System :

A. Temperature Limit Control : This heater is equipped with a Temperature Limit Control designed to turn off the heater should the internal temperature rise to an unsafe level. If this device activates and turns your heater off it may require service.

MODELS	Internal Shut-Off Temp. Plus/Minus 10 Degrees	Reset Temperature Plus/Minus 10 Degrees
RMC-KFA45DGD/75TDGD	176°F/80°C	122°F/50°C
RMC-KFA125/170TDGD	230°F/110°C	194°F/90°C
RMC-KFA210TDGD/210TDGD-1	194°F/90°C	140°F/60°C

Once the temperature falls below the reset temperature you will be able to start your heater.

B. Electrical System Protection : This heaters electrical system is protected by a fuse mounted to the PCB assembly that protects it and other electrical components from damage. If your heater fails to operate check this fuse first and replace as needed.

FUSE TYPE:	All Models	125 volt / 8 amps
-------------------	------------	-------------------

C. Flame-Out Sensor : Utilizes a photocell to monitor the flame in burn chamber during normal operation. It will cause the heater to shut-off should the burner flame extinguish.

NEVER LEAVE THE HEATER UNATTENDED WHILE BURNING!

6. FUELING YOUR HEATER

NEVER FILL THE HEATER FUEL TANK IN THE LIVING SPACE : FILL THE TANK OUTDOORS. DO NOT OVERFILL YOUR HEATER AND BE SURE HEATER IS LEVELED. IMPORTANT NOTICE REGARDING FIRST IGNITION OF HEATER :

The first time you light the heater, it should be done outdoors. This allows the oils, etc. used in manufacturing the heater to burn off outside.

▲ WARNING!! : NEVER REFILL HEATER FUEL TANK WHEN HEATER IS OPERATING OR STILL HOT.

7. OPERATION

A.) VENTILATION

RISK OF INDOOR AIR POLLUTION/USE HEATER ONLY IN WELL VENTILATED AREAS.

Provide a fresh air opening of at least three square feet (2,800 sq. cm) for each 100,000 BTU/Hr. rating. Provide extra fresh air if more heaters are being used.

Example :

A RMC-KFA210TDGD/210TDGD-01 heaters require one of the following:

- a two-car garage door raised six inches (15.24 cm)
- a single-car garage door raised nine inches (22.86 cm)
- two, thirty-inch (76.20 cm) windows raised fifteen inches (38.1 cm)

B.) OPERATION

TO START HEATER

1. Fill fuel tank with kerosene or No. 1 fuel oil.
2. Attach fuel cap.
3. Plug power cord of heater into three-prong, grounded extension cord. Extension cord must be at least six feet long. Extension Cord Wire Size Requirements
 - 6 to 10 feet (1.8 to 3 meters) long, use 18 AWG conductor.
 - 11 to 100 feet (3.4 to 30.5 meters) long, use 16 AWG conductor.
 - 101 to 200 feet (30.8 to 61 meters) long, use 14 AWG conductor.
4. Turn "THERMOSTAT CONTROL Knob" to desired setting (Setting range : 40°F ~ 110°F) (RMC-KFA75/125/170/210TDGD/210TDGD-01 Models Only)
5. Turn "BTU control Knob" to desired level "High or LOW" (KFA210TDGD-01 Model only, See Figure 10.)
6. Push Power Switch to "ON" position, Power Indicator Lamp will light and heater will start. If heater does not start, the thermostat setting may be too low, turn "thermostat Control Knob" to higher position to start heater. If heater still does not start, turn power switch to "OFF" and then to "ON" position. If heater still does not start, see Troubleshooting Guide on page 16.

NOTE : User can change BTU LEVEL "High or Low" while in operation by turnig BTU Control Knob. If heater is operated by HIGH BTU LEVEL, Turn BTU Control Knob 90° to clockwise. If heater is operated by LOW BTU LEVEL, Turn BTU Control Knob 90° to counter clockwise.

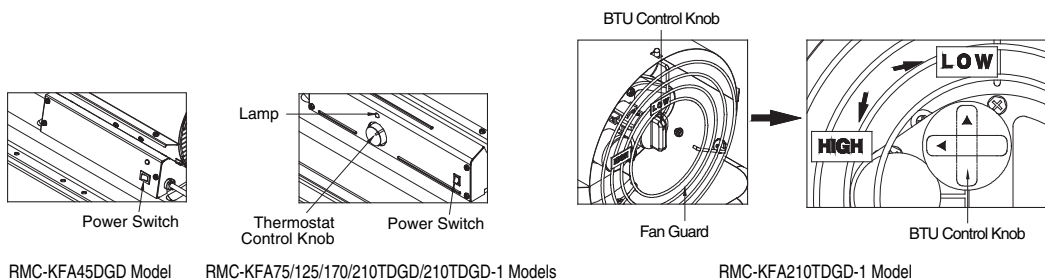

Figure 10. Controls for All Models

**NEVER LEAVE THE HEATER
UNATTENDED WHILE BURNING!**

NOTICE : The major electrical components of this heater are protected by a safety fuse mounted to the PCB board.
If your heater fails to start, check this fuse first and replace as necessary. You should also check your power source to insure that proper voltage and frequency are being supplied to the heater.

TO STOP HEATER

1. Turn switch to “OFF” and unplug power cord.

TO RESTART HEATER

1. Wait 10 seconds after stopping heater.
2. Repeat steps under to start heater.

8. LONG TERM STORAGE OF YOUR HEATER

FUEL TANK DRAIN

1. Drain fuel tank through fuel cap opening.
(For RMC-KFA45DGD/75TDGD Models Only)
2. Remove drain plug from rear bottom side of fuel tank by pulling plug grip downward and drain.
(For RMC-KFA125/170/210TDGD/210TDGD-01 Models Only. See Figure 11)
3. Using a small amount of kerosene, swirl and rinse the inside of the tank.
NEVER mix water with the kerosene as it will cause rust inside the tank.
Pour the kerosene out making sure that you remove it all.
IMPORTANT : Do not store kerosene over summer months for use during next heating season.
Using old fuel could damage heater.
4. Reinstall fuel cap. Properly dispose of old and dirty fuel. (For RMC-KFA45DGD/75TDGD Models Only)
5. Reinstall Drain Plug as follows.
(For RMC-KFA125/170/210TDGD//210TDGD-01 Models Only. See Figure 12)
 - Insert plug’s seal head fully into drain hole so that flange is flush to tank’s bottom.
 - Insert seal cap fully into head hole so that cap flange is flush to head flange.

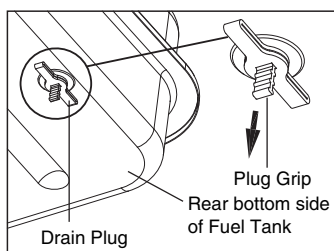

Figure 11. Drain Plug Removal

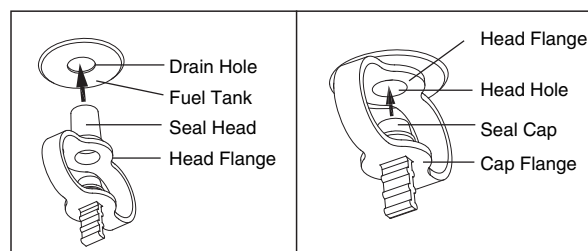

Figure 12. Drain Plug Reinstall

IMPORTANT : Reinstall plug fully into hole in tank, Otherwise it will not seal completely.

6. Store heater in dry well ventilated area. Make sure storage place is free of dust and corrosive fumes.
7. Store the heater in the original box with the original packing material and keep the USER’S MANUAL with the heater.

**NEVER LEAVE THE HEATER
UNATTENDED WHILE BURNING!**

9. MAINTENANCE

▲ WARNING!! : NEVER SERVICE HEATER WHILE IT IS PLUGGED IN OR WHILE HOT!

USE ORIGINAL EQUIPMENT REPLACEMENT PARTS. Use of third party or other alternate components will void warranty and may cause unsafe operating conditions.

A.) FUEL TANK

FLUSH EVERY 200 HOURS OF OPERATION OR AS NEEDED (SEE STORAGE, PAGE 9)

B.) AIR INTAKE FILTER

WASH AND DRY WITH SOAP AND WATER EVERY 500 HOURS OF OPERATION OR AS NEEDED.

- Remove screws along each side of heater using medium phillips screwdriver.
- Lift upper shell off.
- Remove fan guard.
- Wash or replace air intake filter.
- Reinstall fan guard and upper shell.

C.) AIR OUTPUT FILTER, LINT FILTER

REPLACE EVERY 500 HOURS OF OPERATION OR ONCE A YEAR.

- Remove upper shell and fan guard (See Air Intake Filter).
- Turn Air pressure gauge counter-clock wise and remove. (RMC-KFA170/210TDGP/210TDGP-01 Models Only)
- Remove end filter cover screws using medium phillips screwdriver.
- Remove end filter cover.
- Replace air output and lint filter.
- Reinstall end filter cover.
- Reinstall air pressure gauge. (RMC-KFA170/210TDGP/210TDGP-01 Models Only)
- Reinstall fan guard and upper shell.

D.) FAN BLADES

CLEAN EVERY SEASON OR AS NEEDED.

- Remove upper shell (See Air Intake Filter).
- Use M6 allen wrench to loosen set screw which holds fan blade to motor shaft.
- Slip fan blade off motor shaft.
- Clean fan blade using a soft cloth moistened with kerosene or solvent.
- Dry fan blade thoroughly.
- Reinstall fan blade on motor shaft. Place fan blade hub flush with end of motor shaft.
- Place set screw on flat of shaft. Tighten set screw firmly (40-50 inch-pounds/4.5-5.6 N-m).
- Reinstall upper shell.

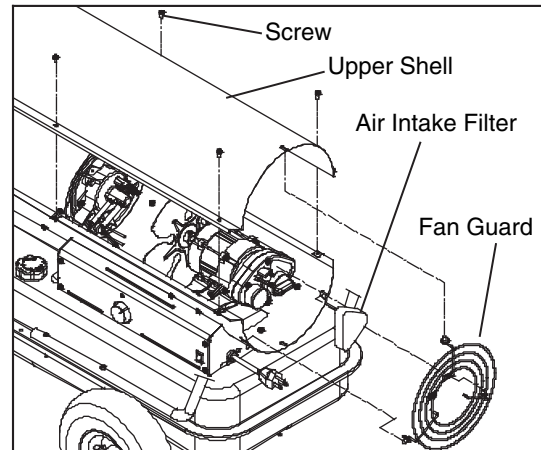

Figure 13. Air Intake Filter Access

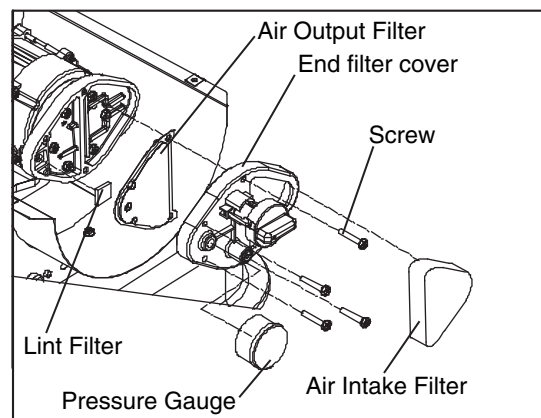

Figure 14. Air Output Filter Access

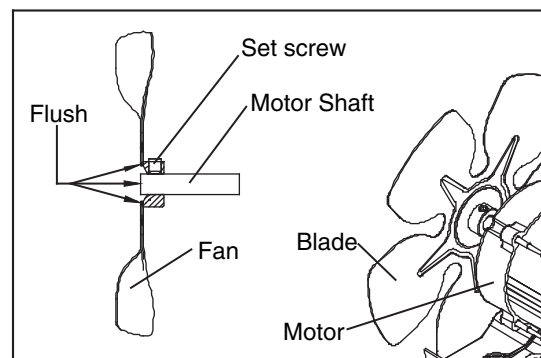

Figure 15. Fan Assembly

NEVER LEAVE THE HEATER UNATTENDED WHILE BURNING!

E.) NOZZLE

REMOVE DIRT IN NOZZLE AS NEEDED (SEE PAGE 16).
(For RMC-KFA45DGD/75/125/170TDGD Models Only)

- Remove upper shell (See page 10).
- Remove fan blade (See page 10).
- Remove fuel and air line hoses from burner head.
- Remove ignitor wire from spark plug.
- Remove three screws using medium phillips screwdriver and remove burner head from combustion chamber.
- Remove spark plug from burner head using medium phillips screwdriver.
- Carefully remove nozzle from burner head using 5/8" socket wrench.
- Blow compressed air through face of nozzle. (this will remove any dirty in nozzle)
- Reinstall nozzle into burner head and tighten firmly. (80~110 inch-pounds)
- Reinstall spark plug in burner head.
- Attach burner head to combustion chamber.
- Attach ignitor wire to spark plug.
- Attach fuel and air line hoses to burner head.
- Reinstall fan blade and upper shell.

(For RMC-KFA210TDGD/210TDGD-01 Models Only)

- Remove upper shell (See page 10).
- Remove fan (See page 10).
- Remove fuel and air line hoses from adaptor-nozzle.
- Remove ignitor wire from spark plug.
- Remove four screws using medium phillips screwdriver and remove burner-bracket from combustion chamber.
- Remove spark plug from burner head using medium phillips screwdriver.
- Carefully remove nozzle from adaptor-nozzle using 5/8" socket wrench.
- Blow compressed air through face of nozzle. (this will remove any dirt in nozzle)
- Reinstall nozzle into adaptor-nozzle and tighten firmly. (80~110 inch-pounds)
- Reinstall spark plug in spark-bracket.
- Attach burner-bracket to combustion chamber.
- Attach ignitor wire to spark plug.
- Attach fuel and air line hoses to adaptor-nozzle.
- Reinstall fan blade and upper shell.

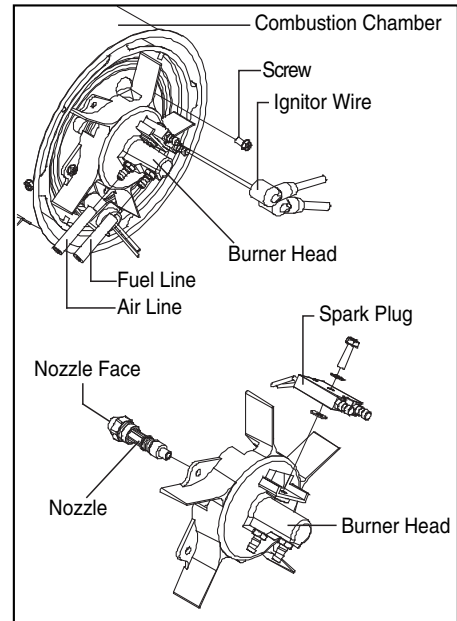

Figure 16. Nozzle Replacement

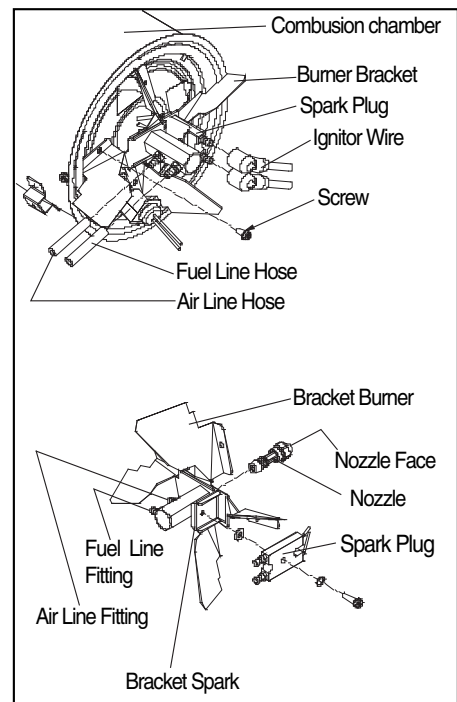

Figure 17. Nozzle Replacement

**NEVER LEAVE THE HEATER
UNATTENDED WHILE BURNING!**

F.) SPARK PLUG

CLEAN AND REGAP EVERY 600 HOURS
OPERATION OR REPLACE AS NEEDED.
(For RMC-KFA45DGD/75/125/170TDGD Models Only)

- Remove upper shell (See page 10).
- Remove fan (See page 10).
- Remove ignitor wire from spark plug.
- Remove spark plug from burner head using medium phillips screwdriver.
- Clean and regap spark plug electrodes to 3.5mm gap.
- Reinstall spark plug in burner head.
- Attach ignitor wire to spark plug.
- Reinstall fan and upper shell.

(For RMC-KFA210TDGD/210TDGD-01 Models Only)

- Remove upper shell (See page 10).
- Remove fan (See page 10).
- Remove ignitor wire from spark plug.
- Remove spark plug from spark-bracket using medium phillips screwdriver.
- Clean and regap spark plug electrodes to 3.5mm gap. (0.138")
- ReInstall spark plug in spark-bracket.
- Attach ignitor wire to spark plug.
- Reinstall fan and upper shell.

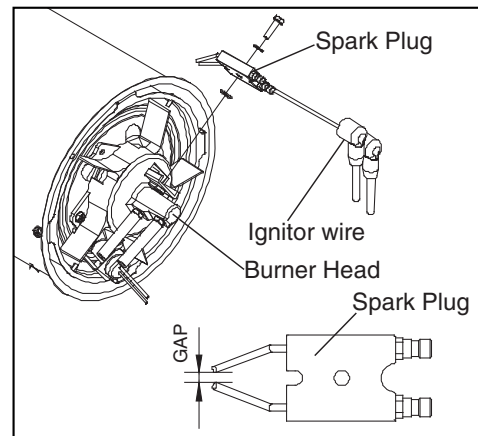

Figure 18. Spark Plug Regap

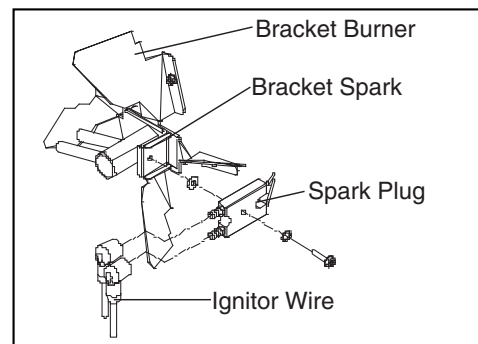

Figure 19. Spark Plug Regap

G.) PHOTOCELL

CLEAN PHOTOCELL ANNUALLY OR AS
NEEDED.

- Remove upper shell (See page 10).
- Remove fan (See page 10).
- Remove photocell from it's mounting.
Clean photocell lens with cotton swab.

TO REPLACE:

- Remove side cover screws using medium phillips screwdriver.
- Disconnect switch wires from power switch and remove side cover.
- Disconnect wires from circuit board and remove photocell.
- Install new photocell and connect wires to circuit board.
- Replace switch wires to power switch and side cover.
- Replace fan and upper shell.

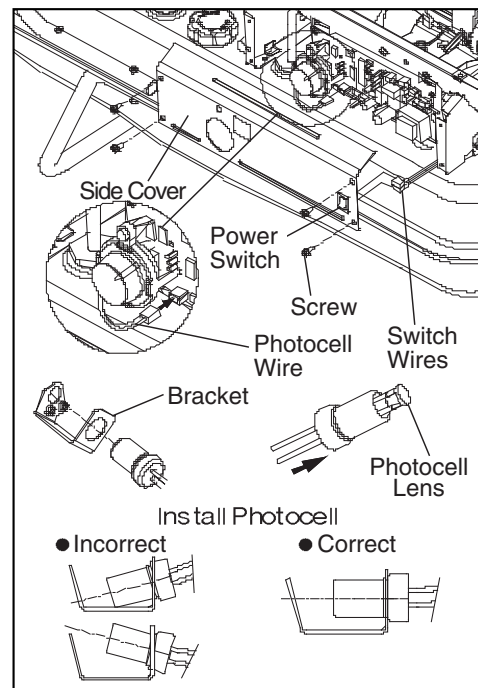

Figure 20. Photocell Replacement

NEVER LEAVE THE HEATER UNATTENDED WHILE BURNING!

H.) FUEL FILTER

CLEAN OR REPLACE TWICE A HEATING SEASON OR AS NEED.

- Remove side cover screws using medium phillips screwdriver.
- Disconnect switch wires from power switch and remove side cover.
- Pull fuel line off fuel filter neck.
- Turn fuel filter 90° to counter clockwise and pull to remove (RMC-KFA45DGD/75TDGD Models only).
- Turn fuel filter 90° to clockwise and pull to remove (RMC-KFA125/170/210TDGD/210TDGD-01 Models only).
- Wash fuel filter with clean fuel and replace in tank.
- Attach fuel line to fuel filter neck.
- Replace switch wires to power switch.
- Reinstall side cover.

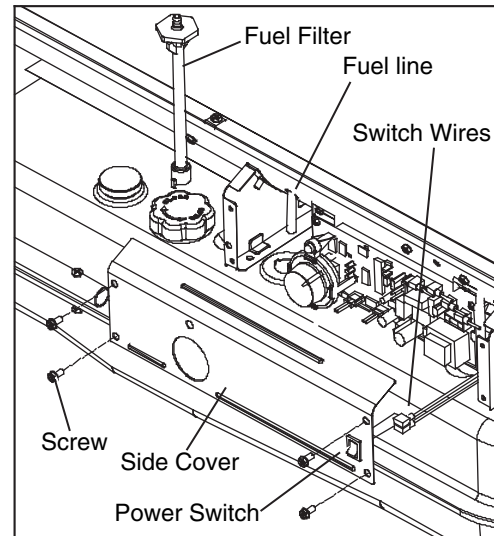

Figure 21. Fuel Filter Replacement

I.) PUMP PRESSURE ADJUSTMENT

- Remove Pressure Gauge Plug from End Filter Cover and install accessory Pressure Gauge. (RMC-KFA45DGD/75/125TDGD Model Only)
- Turn BTU Control Knob to High BTU level. (RMC-KFA210TDGD-01 Model Only, See Operation, page 9)

NOTE : Low BTU level pump pressure is increased or decreased according to High BTU level pump pressure. So, in case need Pump pressure adjusting, Only adjust High BTU level pump pressure.

- Start heater. (See Operation, page 9)
Allow motor to reach full speed.
- Adjust pressure. (Using a flat blade screwdriver)
Turn relief valve to clockwise to increase pressure.
Turn relief valve to counter clockwise to decrease pressure.
- Set pump pressure to correct pressure for each model.
- Stop heater. (See Operation, page 9)

Model	Pump Pressure	
	Pump Pressure	LOW BTU level
RMC-KFA45DGD	2.8 psi	N/A
RMC-KFA75TDGD	3.8 psi	N/A
RMC-KFA125TDGD	5.5 psi	N/A
RMC-KFA170TDGD	6.5 psi	N/A
RMC-KFA210TDGD	8.5 psi	N/A
RMC-KFA210TDGD-01	8.5 psi	6.5 psi

NOTE : USE ONLY ORIGINAL EQUIPMENT REPLACEMENT PARTS. Use of alternate or third party components will void any warranty and may cause unsafe operation condition.

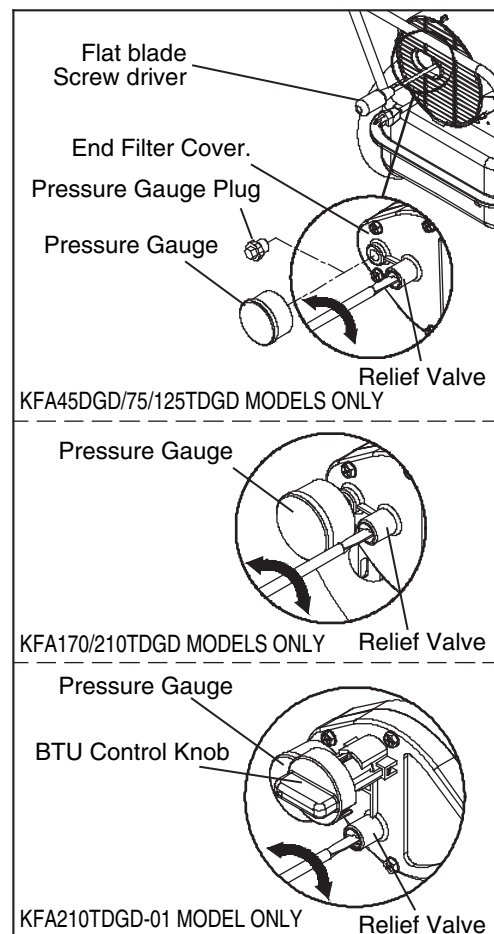

Figure 22. Adjusting Pump Pressure

**NEVER LEAVE THE HEATER
UNATTENDED WHILE BURNING!**

10. REPLACING FUSE

NOTICE : This heater is fuse protected.

If your heater fails to ignite, DO NOT RETURN YOUR HEATER TO THE STORE.

Please follow the simple instruction below to inspect and change the fuse.

PROCEDURE FOR REPLACING FUSE

⚠ WARNING : SHOCK HAZARD

To prevent personal injury, unplug the power cord before replacing fuse.

1. Unplug heater.
2. Remove side cover screws using medium phillips screw driver.
3. Disconnect switch wires from power switch.
4. Remove fuse from fuse holder.(See Figure 23)
5. Replace fuse with enclosed fuse.

⚠ WARNING : FIRE HAZARD

To avoid fire, Do not substitute with a higher or lower current rating.

6. Replace switch wires to power switch.
7. Replace side cover.

NOTE : Specified fuse rating : AC 125/8A

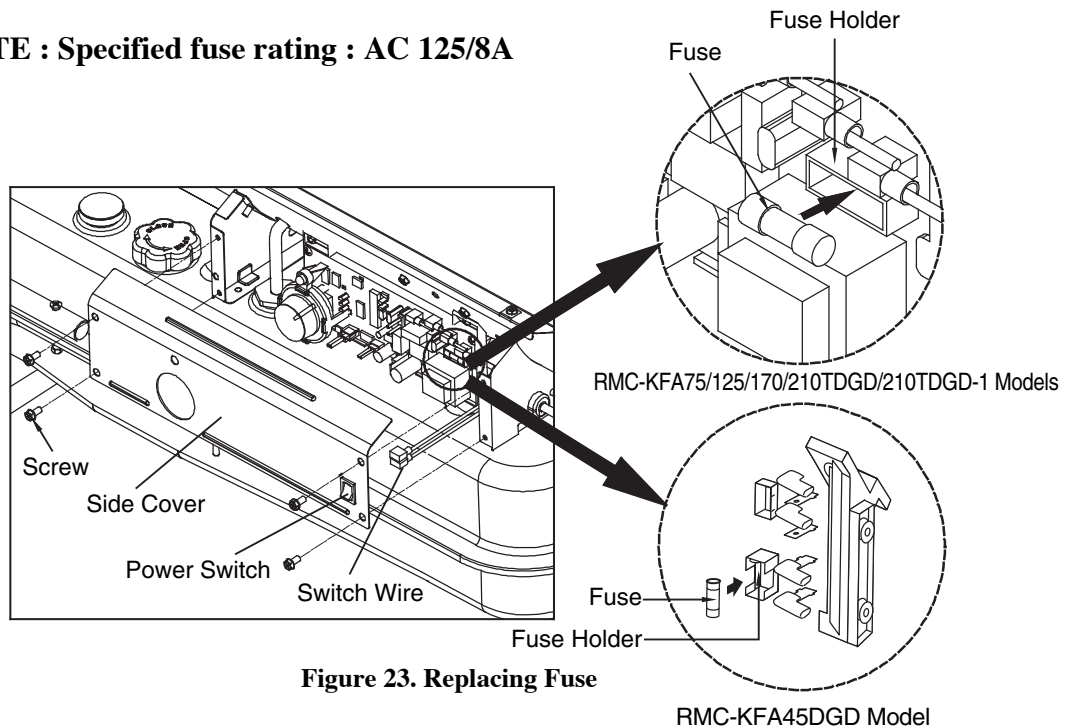

**NEVER LEAVE THE HEATER
UNATTENDED WHILE BURNING!**

11. TROUBLE SHOOTING GUIDE

TROUBLE	POSSIBLE CAUSE	CORRECTIVE ACTION
Heater ignites but MAIN PCB assembly shuts heater off after a short period of time. (Indicator Lamp is flickering and room temp. display indicates " E1 ")	<ol style="list-style-type: none"> 1. Wrong pump pressure 2. Dirty Air Output,Air Intake or Lint Filter. 3. Dirty Fuel Filter. 4. Dirt in Nozzle. 5. Dirty Photocell Lens. 6. Photocell Assembly not Properly installed.(Not seeing the flame) 7. Bad electrical connection between photocell and MAIN PCB assembly. 8. Defective Photocell. 	<ol style="list-style-type: none"> 1. See Pump Pressure Adjustment, Page 14. 2. See Air Output,Air intake and Lint Filters, page 11. 3. See Fuel Filter, Page 14. 4. See Nozzle, Page 12. 5. Clean Photocell Lens, Page 13. 6. Make sure photocell boot is properly seated in bracket, Page 13. 7. Check electrical components See wiring diagram, Page 17. 8. Replace Photocell, Page 13.
Heater will not ignite but motor runs for a short period of time.(Indicator Lamp is flickering and room temp.display indicates " E1 ")	<ol style="list-style-type: none"> 1. No fuel in tank. 2. Wrong pump pressure. 3. Carbon deposits on spark plug and/or improper gap. 4. Dirty fuel filter. 5. Dirt in Nozzle. 6. Water in fuel tank. 7. Bad electrical connection between ignitor and MAIN PCB assembly. 8. Ignitor wire is not attached to spark plug. 	<ol style="list-style-type: none"> 1. Fill tank with kerosene. 2. See Pump Pressure Adjustment, Page 14. 3. See Spark Plug,Page 13. 4. See Fuel Filter,Page 14. 5. See Nozzle,Page 12. 6. Flush fuel tank with clean kerosene, Page 10. 7. Check electrical components See wiring diagram, Page 17. 8. Attach ignitor wire to spark plug. See Spark Plug, Page 13.
Fan does not turn when heater is plugged in and power switch was in the " ON " Position. (Indicator Lamp is on or flickering)	<ol style="list-style-type: none"> 1. Thermostat setting is too low. 2. Bad electrical connection between motor and MAIN PCB assembly. 	<ol style="list-style-type: none"> 1. Turn thermostat control knob to a higher setting. 2. Check electrical connections, See Wiring Diagram, Page 17.
(Indicator Lamp is flickering and room temp. display indicates "E2")	<ol style="list-style-type: none"> 1. Room Temp. sensor disconnected. 2. Sensor Failure. 	<ol style="list-style-type: none"> 1. Reconnect sensor. See Wiring diagram, Page 17. 2. Replace sensor. See Wiring diagram, Page 17.
(Indicator Lamp is flickering and room temp. display indicates "E3")	<ol style="list-style-type: none"> 1. Thermostat switch failure. 	<ol style="list-style-type: none"> 1. Replace switch. See Wiring diagram, Page 17.
Heater will not turn-on (Indicator Lamp is off)	<ol style="list-style-type: none"> 1. Temperature limit safety device is overheated. 2. No electrical power 3. Blown fuse. 4. Bad electrical connection between temperature limit safety device and PCB board. 	<ol style="list-style-type: none"> 1. Turn power switch to "OFF" and allow to cool(about 10 min.) 2. Check to insure heater cord and extension cord are plugged in. Check power supply. 3. Replace safety fuse in PCB board. 4. Check electrical connections See Wiring Diagram, Page 17.

**NEVER LEAVE THE HEATER
UNATTENDED WHILE BURNING!**

12. WIRING DIAGRAM

A) WIRING DIAGRAM (RMC-KFA45DGD Model)

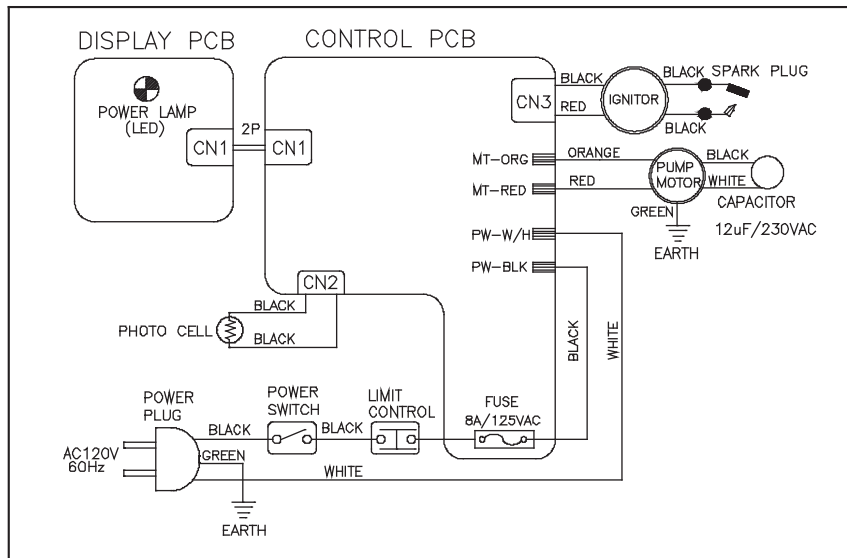

B) WIRING DIAGRAM (RMC-KFA75TDGD Model)

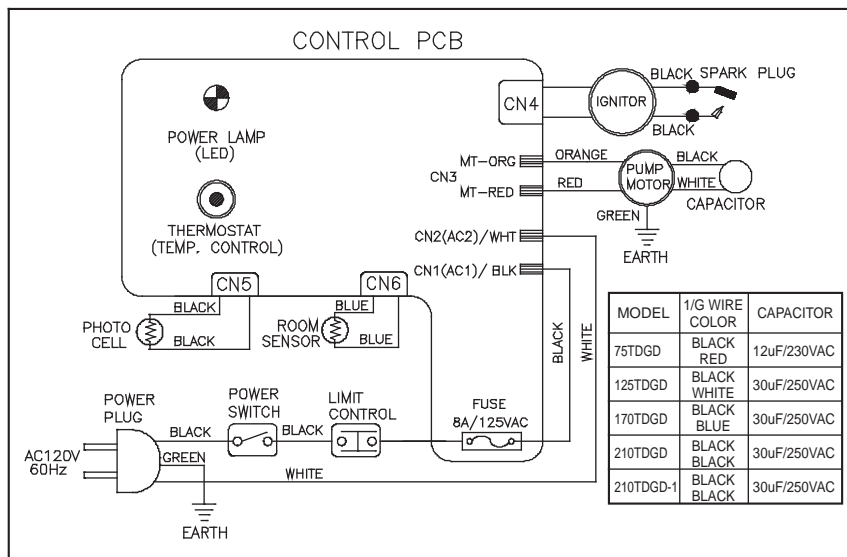

**NEVER LEAVE THE HEATER
UNATTENDED WHILE BURNING!**

13. SPECIFICATIONS

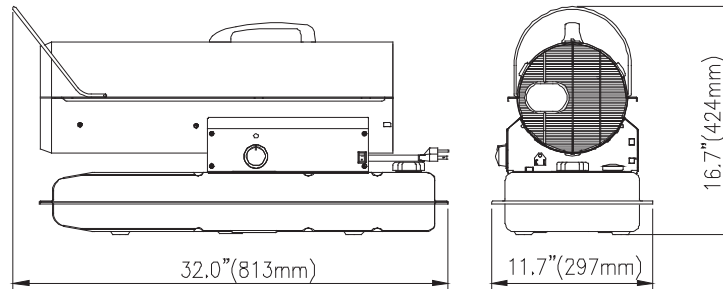

RMC-KFA45DGD/75TDGD Models

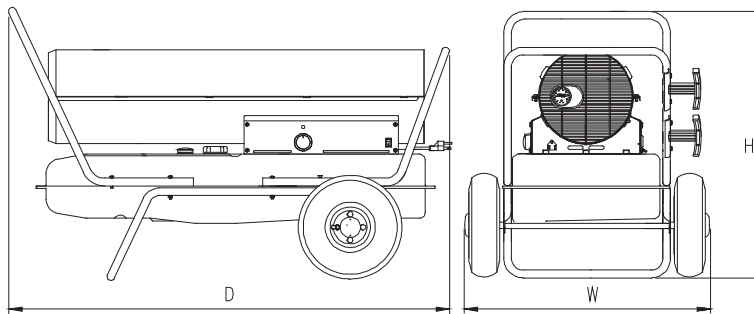

	125TDGD	170/210TDGD
D	36.0"(914 mm)	43.5"(1105 mm)
W	19.0"(483 mm)	23.9"(607 mm)
H	23.0"(584 mm)	26.6"(675 mm)

RMC-KFA125/170/210TDGD/210TDGD-01 Models

MODEL		RMC-KFA45DGD	RMC-KFA75TDGD	RMC-KFA125TDGD	RMC-KFA170TDGD	RMC-KFA210TDGD	RMC-KFA210TDGD-01
BTU/Hr	HIGH	45,000	75,000	125,000	170,000	210,000	210,000
	LOW	N/A	N/A	N/A	N/A	N/A	170,000
Fuel Consumption - Gal./Hr(ℓ./Hr)	HIGH	0.35(1.32)	0.57(2.16)	0.95(3.60)	1.30(4.92)	1.60(6.06)	1.60(6.06)
	LOW	N/A	N/A	N/A	N/A	N/A	1.30(4.92)
Fuel Tank Capacity - Gal.(ℓ)		5.0(18.9)	5.0(18.9)	10.0(37.9)	13.0(49.2)	13.0(49.2)	13.0(49.2)
Pump Pressure PSI (kgf/cm ²)	HIGH	2.8(0.20)	3.8(0.27)	5.5(0.39)	6.5(0.46)	8.5(0.60)	8.5(0.60)
	LOW	N/A	N/A	N/A	N/A	N/A	6.5(0.46)
Volt/Hz		120Vac/60Hz	120Vac/60Hz	120Vac/60Hz	120Vac/60Hz	120Vac/60Hz	120Vac/60Hz
Amps.		1.6	1.6	2.5	3.2	3.7	3.7
Phase		1	1	1	1	1	1
Size(D × W × H), Inch(mm)		32.0 × 11.7 × 16.7 (813 × 297 × 424)	32.0 × 11.7 × 16.7 (813 × 297 × 424)	38.0 × 19.0 × 23.0 (914 × 483 × 584)	43.5 × 23.9 × 26.6 (1105 × 607 × 675)	43.5 × 23.9 × 26.6 (1105 × 607 × 675)	43.5 × 23.9 × 26.6 (1105 × 607 × 675)
Weight Lbs.(kg)		26.5(12.0)	26.5(12.0)	46.3(21.0)	56.0(25.5)	62.0(28.0)	62.0(28.0)

**NEVER LEAVE THE HEATER
UNATTENDED WHILE BURNING!**

14. EXPLODED PARTS DRAWING (RMC-KFA45DGD/75/125/170TDGD Models Only)

NOTE : SPECIFY MODEL NUMBER AND PART NUMBER WHEN ORDERING PARTS.

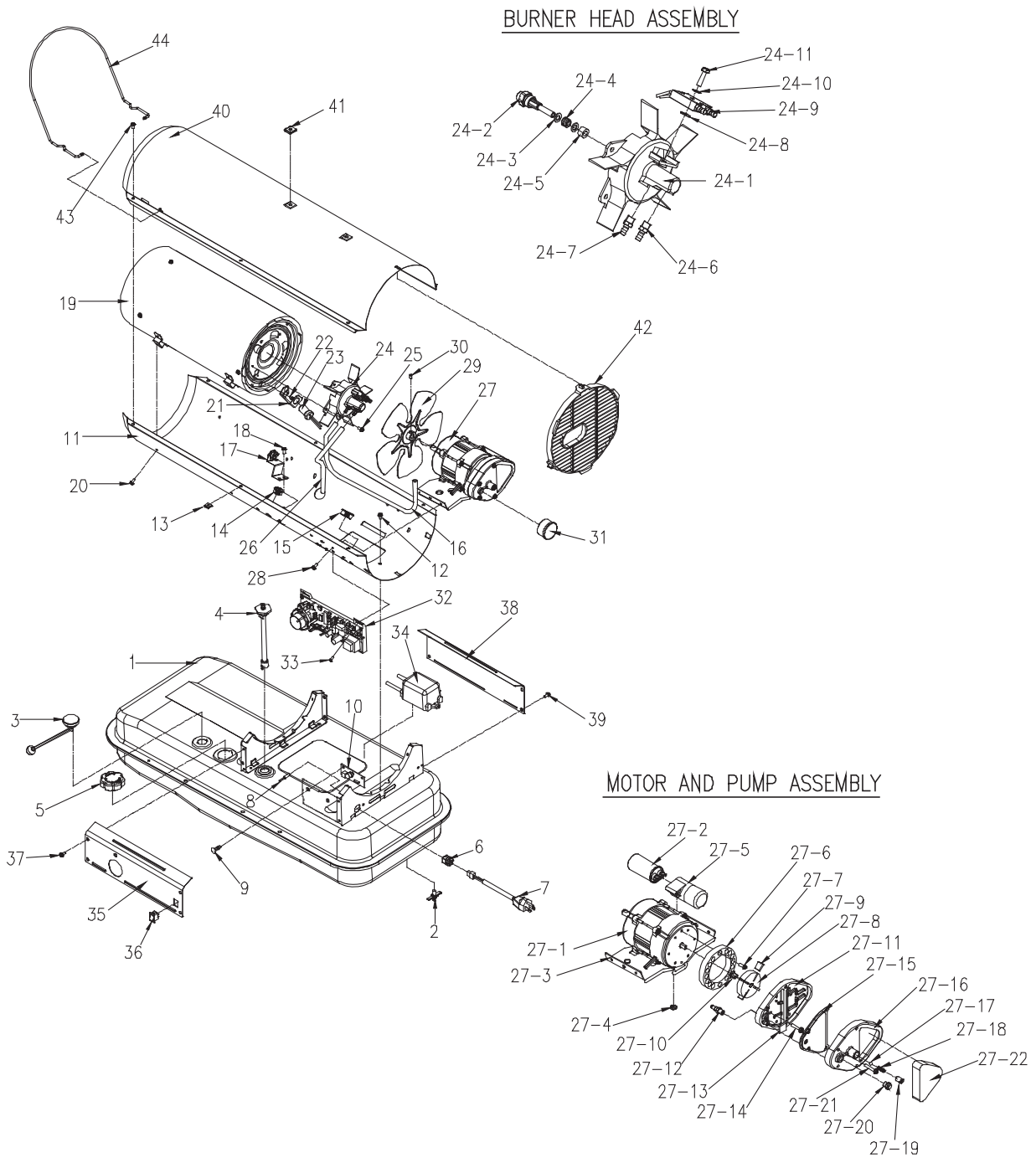

**NEVER LEAVE THE HEATER
UNATTENDED WHILE BURNING!**

14. EXPLODED PARTS DRAWING (RMC-KFA 210TDGD/210TDGD-01 Models Only)

NOTE : SPECIFY MODEL NUMBER AND PART NUMBER WHEN ORDERING PARTS.

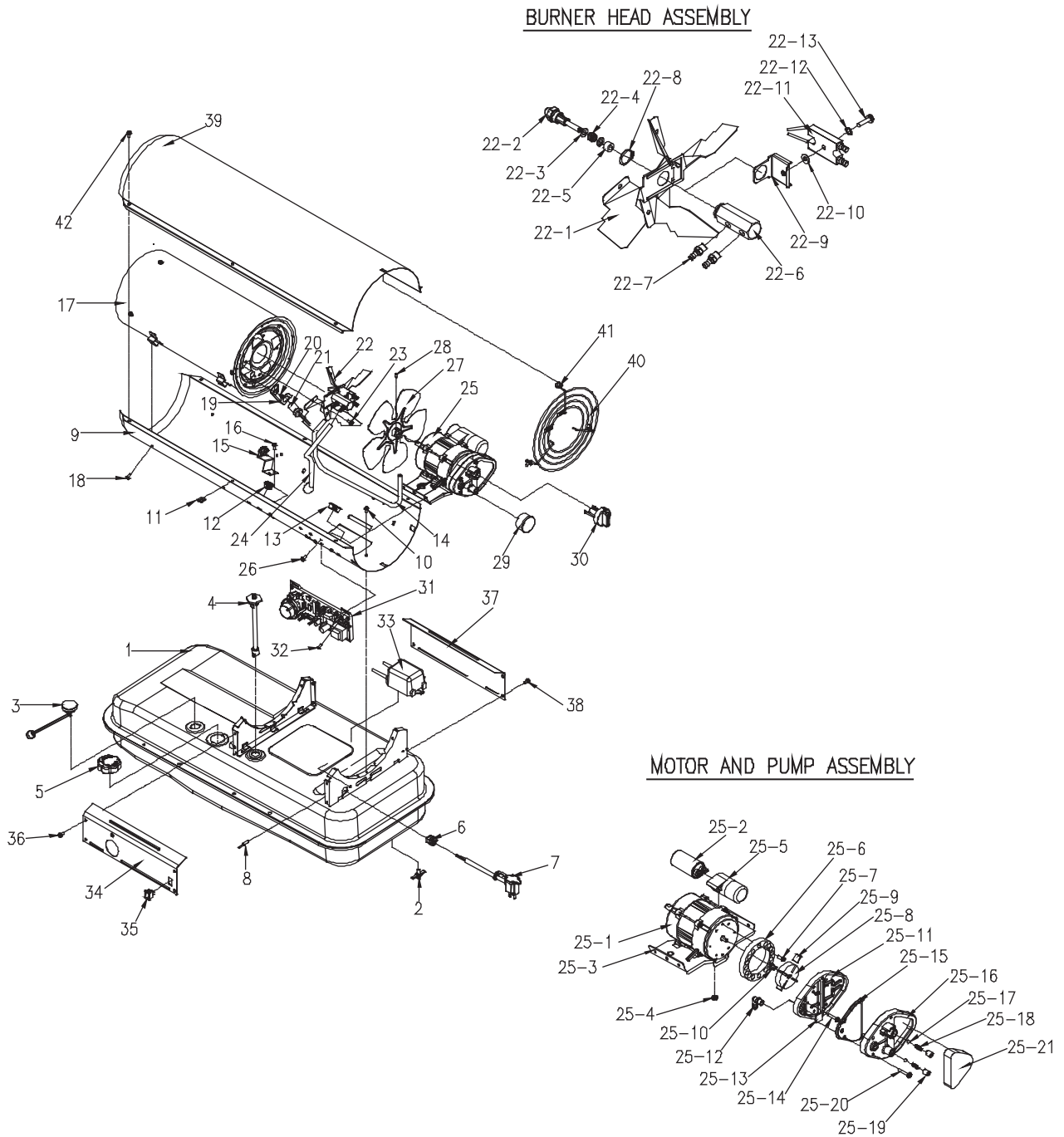

**NEVER LEAVE THE HEATER
UNATTENDED WHILE BURNING!**

15. PARTS LIST (RMC-KFA45DGD/75/125/170TDGD Models Only)

KEY NO.	DESCRIPTION	PART NO.				Quantity
		RMC-KFA45DGD	RMC-KFA75TDGD	RMC-KFA125TDGD	RMC	
1	Fuel Tank Assmebly	2151-0005-00	2151-0007-00	2151-0008-00	2151-0009-00	1
2	Drain-Plug	-	-	3331-0051-00	3331-0051-00	1
3	Fuel Gauge	2156-0005-00	2156-0005-00	2156-0001-00	2156-0001-00	1
4	Fuel Filter Assmby	2155-0005-00	2155-0005-00	2155-0001-00	2155-0001-00	1
5	Fuel Cap	2151-0003-00	2151-0003-00	2151-0003-00	2151-0003-00	1
6	Cord Bushing	3712-0013-00	3712-0013-00	3712-0013-00	3712-0013-00	1
7	Power Cord	3980-0031-00	3980-0031-00	3980-0031-00	3980-0031-00	1
8	Thermistor	-	38C0-0054-00	38C0-0054-00	38C0-0054-00	1
9	Button Support	3713-0048-00	-	-	-	2
10	Display P.C.B Assembly	215A-0013-00	-	-	-	1
11	Shell Lower	3111-0209-08	3111-0209-08	3111-0210-08	3111-0211-08	1
12	Flange Screw	4319-0015-00	4319-0015-00	4319-0015-00	4319-0015-00	6
13	Clip Nut	3131-0182-00	3131-0182-00	3131-0182-00	3131-0182-00	6
14	Bushing-Grommet(S)	3231-0120-00	3231-0120-00	3231-0120-00	3231-0120-00	1
15	Bushing-Grommet(L)	3231-0121-00	3231-0121-00	3231-0121-00	3231-0121-00	1
16	Air-Line	3341-0007-00	3341-0007-00	3341-0002-00	3341-0004-00	1
17	Temperature Limit Assembly	2153-0003-00	2153-0003-00	2153-0001-00	2153-0001-00	1
18	Flange-Screw	4319-0015-00	4319-0015-00	4319-0015-00	4319-0015-00	2
19	Chamber Assembly	2152-0069-00	2152-0043-00	2152-0046-00	2152-0049-00	1
20	Flange Screw	4319-0015-00	4319-0015-00	4319-0015-00	4319-0015-00	4
21	Bracket Photocell	3131-0244-00	3131-0159-00	3131-0159-00	3131-0159-00	1
22	Screw-BH1	4311-0068-00	4311-0068-00	4311-0068-00	4311-0068-00	2
23	Photocell Assembly	*SP-KFA1007	*SP-KFA1007	*SP-KFA1007	*SP-KFA1007	1
24	Burner Head Assembly	2152-0020-00	2152-0016-00	2152-0006-00	2152-0009-00	1
24-1	Burner Head	3531-0015-00	3531-0015-00	3531-0007-00	3531-0009-00	1
24-2	Nozzle	*SP-KFA1026	*SP-KFA1027	*SP-KFA1003	*SP-KFA1004	1
24-3	Washer-Nozzle Seal	4349-0016-00	4349-0016-00	4349-0016-00	4349-0016-00	2
24-4	Spring-Nozzle Seal	3431-0010-00	3431-0010-00	3431-0010-00	3431-0010-00	1
24-5	O-Ring	3311-0002-00	3311-0002-00	3311-0002-00	3311-0002-00	1
24-6	Nipple	3541-0039-00	3541-0039-00	3541-0020-00	3541-0020-00	1
24-7	Nipple	3541-0020-00	3541-0020-00	3541-0020-00	3541-0020-00	1
24-8	Washer-Fiber	4349-0017-00	4349-0017-00	4349-0017-00	4349-0017-00	1
24-9	Spark Plug	*SP-KFA1008	*SP-KFA1008	*SP-KFA1009	*SP-KFA1009	1
24-10	Washer-Spring	4342-0009-00	4342-0009-00	4342-0009-00	4342-0009-00	1
24-11	Bolt-Flange	4329-0013-00	4329-0013-00	4329-0013-00	4329-0013-00	1
25	Flange Screw	4319-0015-00	4319-0015-00	4319-0015-00	4319-0015-00	3
26	Fuel Line	3341-0009-00	3341-0009-00	3341-0008-00	3341-0008-00	1
27	Motor and Pump Assembly	2154-0050-00	2154-0050-00	2154-0049-00	2154-0048-00	1
27-1	Motor	3970-0034-00	3970-0034-00	3970-0029-00	3970-0033-00	1
27-2	Capacitor	3820-0142-00	3820-0142-00	3820-0143-00	3820-0143-00	1
27-3	Supportor Motor	3121-0189-00	3121-0189-00	3121-0105-00	3121-0105-00	1
27-4	Nut-Hex	4331-0013-00	4331-0013-00	4331-0013-00	4331-0013-00	2

**NEVER LEAVE THE HEATER
UNATTENDED WHILE BURNING!**

15. PARTS LIST (RMC-KFA45DGD/75/125/170TDGD Models Only)

KEY NO.	DESCRIPTION	PART NO.				Quantity
		RMC-KFA45DGD	RMC-KFA75TDGD	RMC-KFA125TDGD	RMC	
27-5	Holder Capacitor	-	-	3231-0152-00	3231-0152-00	1
27-6	Pump Body	3541-0022-00	3541-0022-00	3541-0022-00	3541-0022-00	1
27-7	Bolt-BH Special	4321-0198-00	4321-0198-00	4321-0198-00	4321-0198-00	2
27-8	Rotor	*SP-KFA1000	*SP-KFA1000	*SP-KFA1000	*SP-KFA1000	1
27-9	Blade	See SP-KFA1000	See SP-KFA1000	See SP-KFA1000	See SP-KFA1000	4
27-10	Insert	See SP-KFA1000	See SP-KFA1000	See SP-KFA1000	See SP-KFA1000	1
27-11	End Pump Cover	3531-0008-00	3531-0008-00	3531-0008-00	3531-0008-00	1
27-12	Nipple	3231-0151-00	3231-0151-00	3231-0151-00	3231-0151-00	1
27-13	Lint Filter	*SP-KFA1005	*SP-KFA1005	*SP-KFA1005	*SP-KFA1005	1
27-14	Bolt Flange	4329-0016-00	4329-0016-00	4329-0016-00	4329-0016-00	6
27-15	Output Filter	See SP-KFA1005	See SP-KFA1005	See SP-KFA1005	See SP-KFA1005	1
27-16	End Filter Cover	3221-0029-00	3221-0029-00	3221-0029-00	3221-0029-00	1
27-17	Ball	*SP-KFA1006	*SP-KFA1006	*SP-KFA1006	*SP-KFA1006	1
27-18	Spring	See SP-KFA1006	See SP-KFA1006	See SP-KFA1006	See SP-KFA1006	1
27-19	Adjusting Screw	See SP-KFA1006	See SP-KFA1006	See SP-KFA1006	See SP-KFA1006	1
27-20	Plug	See SP-KFA1006	See SP-KFA1006	See SP-KFA1006	-	1
27-21	Bolt Flange	4329-0016-00	4329-0016-00	4329-0016-00	4329-0016-00	4
27-22	Intake Filter	See SP-KFA1005	See SP-KFA1005	See SP-KFA1005	See SP-KFA1005	1
28	Flange Screw	4319-0015-00	4319-0015-00	4319-0015-00	4319-0015-00	4
29	Fan Assembly	2154-0010-00	2154-0009-00	2154-0004-00	2154-0007-00	1
30	Bolt Headless Hex Socket	4323-0004-00	4323-0004-00	4323-0004-00	4323-0004-00	1
31	Pressure Gauge	-	-	-	3740-0049-00	1
32	Main P.C.B Assembly	215A-0019-00	215A-0026-00	215A-0026-00	215A-0026-00	1
33	Screw-TH2S	4312-0046-00	4312-0046-00	4312-0046-00	4312-0046-00	2
34	Ignitor	39E0-0008-00	39E0-0008-00	39E0-0005-00	39E0-0007-00	1
35	Side Cover-Right	3121-0192-11	3121-0324-16	3121-0351-08	3121-0353-13	1
36	Power Switch	39A0-0044-00	39A0-0044-00	39A0-0044-00	39A0-0044-00	1
37	Flange Screw	4319-0015-00	4319-0015-00	4319-0015-00	4319-0015-00	4
38	Side Cover-Left	3121-0190-00	3121-0350-00	3121-0352-00	3121-0354-00	1
39	Flange Screw	4319-0015-00	4319-0015-00	4319-0015-00	4319-0015-00	4
40	Shell Upper	3111-0213-08	3111-0213-08	3111-0214-08	3111-0215-09	1
41	Clip Nut	3131-0182-00	3131-0182-00	-	-	2
42	Fan Guard	3221-0050-00	3221-0050-00	3221-0051-00	3221-0051-00	1
43	Flange Screw	4319-0015-00	4319-0015-00	4319-0015-00	4319-0015-00	6
44	Front Guard	3561-0066-00	3561-0066-00	-	-	1

FOR TECHNICAL ASSISTANCE SEE YOUR LOCAL RETAILER OR
CONTACT US AT:

Phone : 1-877-447-4768

**NEVER LEAVE THE HEATER
UNATTENDED WHILE BURNING!**

15. PARTS LIST (RMC-KFA210TDGD/210TDGD-01 Models Only)

KEY NO.	DESCRIPTION	PART NO.		Quantity
		RMC-KFA210TDGD	RMC-KFA210TDGD-01	
1	Fuel Tank Assmebly	2151-0009-00	2151-0009-00	1
2	Drain-Plug	3331-0051-00	3331-0051-00	1
3	Fuel Gauge	2156-0001-00	2156-0001-00	1
4	Fuel Filter Assmbly	2155-0001-00	2155-0001-00	1
5	Fuel Cap	2151-0003-00	2151-0003-00	1
6	Cord Bushing	3712-0013-00	3712-0013-00	1
7	Power Cord	3980-0031-00	3980-0031-00	1
8	Thermistor	38C0-0054-00	38C0-0054-00	1
9	Shell Lower	3111-0212-06	3111-0212-06	1
10	Flange Screw	4319-0015-00	4319-0015-00	6
11	Clip Nut	3131-0182-00	3131-0182-00	6
12	Bushing-Grommet(S)	3231-0120-00	3231-0120-00	1
13	Bushing-Grommet(L)	3231-0121-00	3231-0121-00	1
14	Air-Line	3341-0010-00	3341-0010-00	1
15	Temperature Limit Assembly	2153-0005-00	2153-0005-00	1
16	Flange-Screw	4319-0015-00	4319-0015-00	2
17	Chamber Assembly	2152-0041-00	2152-0041-00	1
18	Flange Screw	4319-0015-00	4319-0015-00	4
19	Bracket Photocell	3131-0159-00	3131-0159-00	1
20	Screw-BH1	4311-0068-00	4311-0068-00	2
21	Photocell Assembly	*SP-KFA1007	*SP-KFA1007	1
22	Burner Head Assembly	2152-0031-00	2152-0031-00	1
22-1	Bracket Burner	3121-0256-00	3121-0256-00	1
22-2	Nozzle	*SP-KFA1011	*SP-KFA1011	1
22-3	Washer-Nozzle Seal	4349-0016-00	4349-0016-00	1
22-4	Spring-Nozzle Seal	3431-0010-00	3431-0010-00	1
22-5	O-Ring	3311-0002-00	3311-0002-00	1
22-6	Adaptor Nozzle	3131-0287-00	3131-0287-00	1
22-7	Nipple	3541-0020-00	3541-0020-00	2
22-8	Ring Retaining	4346-0027-00	4346-0027-00	1
22-9	Bracket Spark	3131-0286-00	3131-0286-00	1
22-10	Washer-Fiber	4349-0017-00	4349-0017-00	1
22-11	Spark Plug	*SP-KFA1021	*SP-KFA1021	1
22-12	Washer-Spring	4342-0009-00	4342-0009-00	1
22-13	Bolt-Flange	4329-0013-00	4329-0013-00	1
23	Flange Screw	4319-0015-00	4319-0015-00	4
24	Fuel Line	3341-0019-00	3341-0019-00	1
25	Motor and Pump Assembly	2154-0051-00	2154-0064-00	1
25-1	Motor	3970-0060-00	3970-0060-00	1
25-2	Capacitor	3820-0143-00	3820-0143-00	1
25-3	Supportor Motor	3121-0258-00	3121-0258-00	1
25-4	Nut-Hex	4331-0013-00	4331-0013-00	2

**NEVER LEAVE THE HEATER
UNATTENDED WHILE BURNING!**

15. PARTS LIST (RMC-KFA210TDGD/210TDGD-01 Models Only)

KEY NO.	DESCRIPTION	PART NO.		Quantity
		RMC-KFA210TDGD	RMC-KFA210TDGD-01	
25-5	Holder Capacitor	3231-0152-00	3231-0152-00	1
25-6	Pump Body	3541-0050-00	3541-0050-00	1
25-7	Bolt-BH Special	4321-0198-00	4321-0198-00	2
25-8	Rotor	*SP-KFA1022	*SP-KFA1022	1
25-9	Blade	See SP-KFA1022	See SP-KFA1022	4
25-10	Insert	See SP-KFA1022	See SP-KFA1022	1
25-11	End Pump Cover	3531-0008-00	3531-0008-00	1
25-12	Elbow	3231-0093-00	3231-0093-00	1
25-13	Lint Filter	*SP-KFA1005	*SP-KFA1005	1
25-14	Bolt Flange	4329-0016-00	4329-0016-00	6
25-15	Output Filter	See SP-KFA1005	See SP-KFA1005	1
25-16	End Filter Cover	3221-0029-00	3221-0073-00	1
25-17	Ball	*SP-KFA1006	*SP-KFA1010	1
25-18	Spring	See SP-KFA1006	See SP-KFA1010	1
25-19	Adjusting Screw	See SP-KFA1006	See SP-KFA1010	1
25-20	Bolt Flange	4329-0016-00	4329-0016-00	4
25-21	Intake Filter	See SP-KFA1005	See SP-KFA1005	1
26	Flange Screw	4319-0015-00	4319-0015-00	4
27	Fan Assembly	2154-0007-00	2154-0007-00	1
28	Bolt Headless Hex Socket	4323-0004-00	4323-0004-00	1
29	Pressure Gauge	3740-0049-00	3740-0049-00	1
30	BTU Control Valve	-	2154-0061-00	1
31	Main P.C.B Assembly	215A-0026-00	215A-0026-00	1
32	Screw-TH2S	4312-0046-00	4312-0046-00	2
33	Ignitor	39E0-0014-00	39E0-0014-00	1
34	Side Cover-Right	3121-0353-14	3121-0353-15	1
35	Power Switch	39A0-0044-00	39A0-0044-00	1
36	Flange Screw	4319-0015-00	4319-0015-00	4
37	Side Cover-Left	3121-0329-00	3121-0329-00	1
38	Flange Screw	4319-0015-00	4319-0015-00	4
39	Shell Upper	3111-0215-09	3111-0215-09	1
40	Fan Guard	3561-0058-01	3561-0075-01	1
41	Bushing Fan Guard	3351-0010-00	3351-0010-00	3
42	Flange Screw	4319-0015-00	4319-0015-00	6

FOR TECHNICAL ASSISTANCE SEE YOUR LOCAL RETAILER OR
CONTACT US AT:

Phone : 1-877-447-4768

**NEVER LEAVE THE HEATER
UNATTENDED WHILE BURNING!**

15. PARTS LIST (WHEELS AND HANDLE)

1) RMC-KFA45DGD/75TDGD MODELS

KEY NO.	DESCRIPTION	PART NO.	Quantity
		RMC-KFA45DGD/75TDGD	
1	Handle	3231-0073-00	1
2	Hardware Kit	HW-KFA1000	1

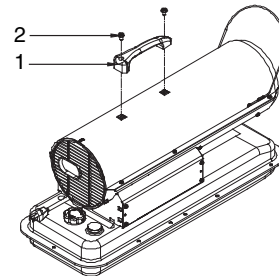

2) RMC-KFA125TDGD MODEL

KEY NO.	DESCRIPTION	PART NO.	Quantity
		RMC-KFA125TDGD	
1	Front Handle	3551-0023-00	1
2	Wheel Support Frame	3551-0014-00	1
3	Axle	3541-0026-00	1
4	Wheel	2156-0003-00	2
5	Hardware Kit	HW-KFA1010	1
5-1	Screw(S)	-	2
5-2	Screw(L)	-	2
5-3	Flange Screw	-	4
5-4	Nut	-	8
5-5	Cotter Pin	-	2
5-6	Washer	-	2

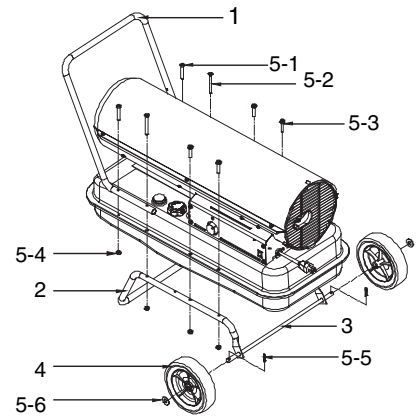

3) RMC-KFA170/210TDGD/210TDGD-01 MODELS

KEY NO.	DESCRIPTION	PART NO.	Quantity
		RMC-KFA170/210TDGD/210TDGD-01	
1	Front Handle	3551-0022-00	1
2	Rear Handle	3551-0034-00	1
3	Wheel Support Frame	3551-0025-00	1
4	Wheel	3720-0007-00	2
5	Axle	3541-0053-00	2
6	Cord Wrap	3551-0042-00	2
7	Wheel Cap	3231-0100-00	2
8	Hardware Kit	HW-KFA1012	1
8-1	Screw(S)	-	2
8-2	Screw(L)	-	6
8-3	Flange Screw	-	4
8-4	Nut	-	12
8-5	Bushing	-	2
8-6	Washer	-	2
8-7	Cotter Pin	-	2

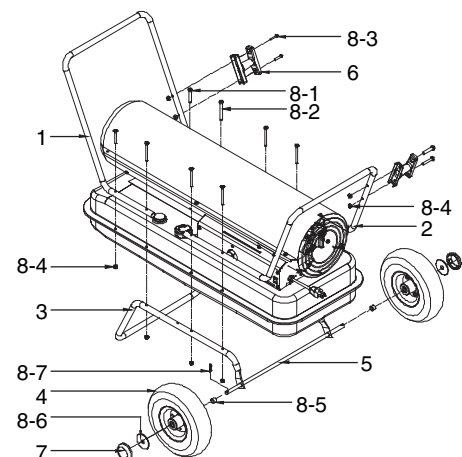

Free Manuals Download Website

<http://myh66.com>

<http://usermanuals.us>

<http://www.somanuals.com>

<http://www.4manuals.cc>

<http://www.manual-lib.com>

<http://www.404manual.com>

<http://www.luxmanual.com>

<http://aubethermostatmanual.com>

Golf course search by state

<http://golfingnear.com>

Email search by domain

<http://emailbydomain.com>

Auto manuals search

<http://auto.somanuals.com>

TV manuals search

<http://tv.somanuals.com>