

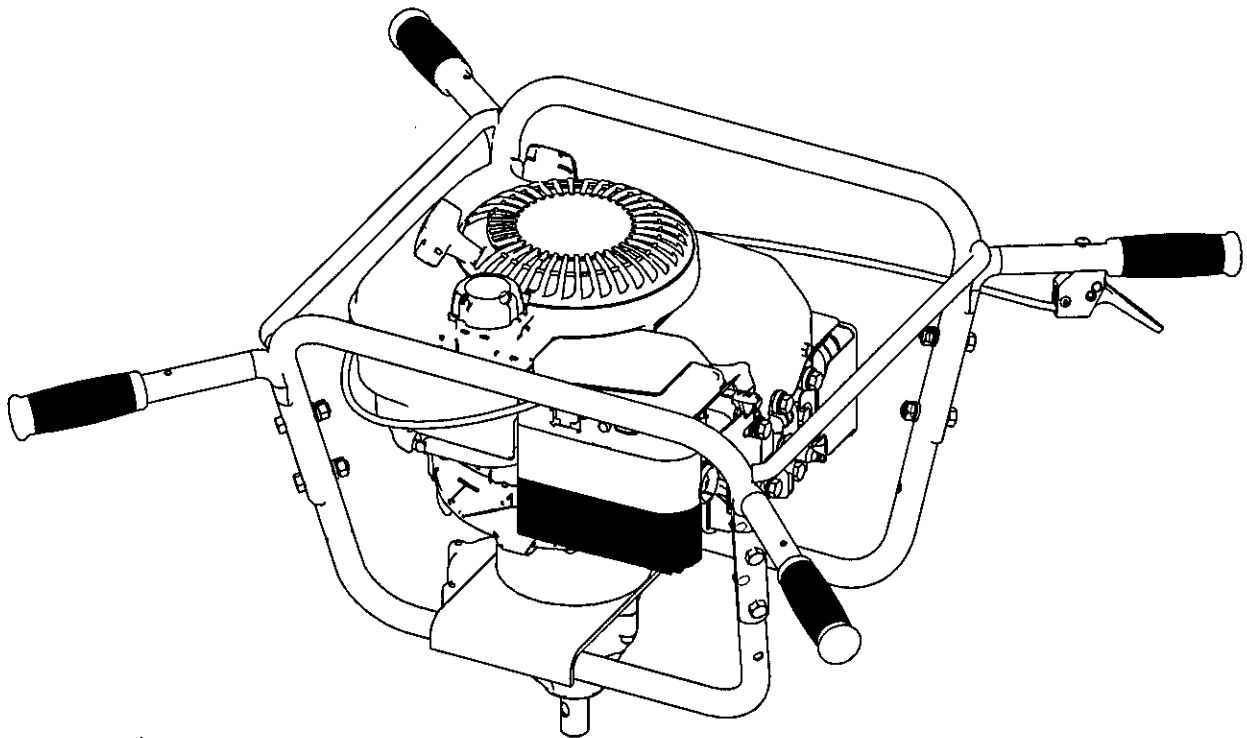

Operator's Manual  
Original Operating Instructions

# Two-Man Earth Auger Powerhead 9800 Series

SN



Includes models:  
9800B  
9800H  
9800BCE (European)

Get parts online at  
[www.getearthquake.com](http://www.getearthquake.com)



P/N: OM9800B  
ECN:10322  
REV5: 03/01/14  
© 2014 Ardisam, Inc.  
All Rights Reserved

## INTRODUCTION

Congratulations on your investment in quality. Thank you for purchasing an Earthquake™ Two-Man Auger Powerhead. We have worked to ensure that this powerhead meets the highest standards for usability and durability. With proper care, this powerhead will provide many years of service.

**Please read this entire manual before installation and use. Earthquake reserves the right to change, alter or improve the product and this document at any time without prior notice.**

## CONTENTS

Introduction/Contents/Registration .....	2
Warnings and Safety Precautions.....	3-7
Features .....	7
Assembly .....	8
Operation .....	9-10
Maintenance and Storage.....	11-12
Troubleshooting and Repair.....	12-13
Illustrated Parts Breakdown.....	14-18
Warranty .....	22
CE Declaration of Conformity .....	23

## REGISTRATION, SERVICE AND MAINTENANCE LOG

Record the model number and serial number in the space provided for easy reference. Warranty is valid only if the completed registration is received by Earthquake within 30 days of purchase. You can register your warranty online by visiting [www.getearthquake.com](http://www.getearthquake.com). If you do not have a computer, call our customer service department at (800) 345-6007 Mondays through Fridays from 8 a.m. to 5 p.m. CST.

<b>OWNERSHIP RECORDS</b>		
Owner's Name:		
Owner's Address:		
City:	State/Province:	Zip Code/Postal Code:
Model Number:	Serial Number:	
Date of Purchase:		
Notes:		

This manual may contain information for several models. Read and keep this manual for future reference. This manual contains important information on **SAFETY, ASSEMBLY, OPERATION, AND MAINTENANCE**. The owner must be certain that all the product information is included with the unit. This information includes the **MANUAL**, the **REPLACEMENT PARTS** and the **WARRANTIES**. This information must be included to make sure state laws and other laws are followed. This manual should remain with the unit even if it is resold.

## WARNINGS AND SAFETY PRECAUTIONS

### OPERATOR'S RESPONSIBILITY

Accurate assembly and safe and effective use of the machine is the operator's responsibility.

- Read and follow all safety instructions.
- Carefully follow all assembly instructions.
- Maintain the machine according to directions and schedule included in this operator's manual.
- Ensure that anyone who uses the machine is familiar with all controls and safety precautions.

### SPECIAL SAFETY MESSAGES

Your manual contains special messages to bring attention to potential safety concerns, machine damage as well as helpful operating and servicing information. Please read all the information carefully to avoid injury and machine damage.

**NOTE:** General information is given throughout the manual that may help the operator in the operation or service of the machine.



This symbol points out important safety instructions which if not followed could endanger your personal safety.

### BEFORE OPERATING ENGINE:



#### WARNING

READ ENTIRE OPERATING AND MAINTENANCE INSTRUCTIONS FOR THIS PRODUCT AND THE INSTRUCTIONS FOR THE ENGINE THAT POWERS THIS UNIT. FAILURE TO FOLLOW INSTRUCTIONS COULD RESULT IN SERIOUS INJURY OR DEATH. OPERATE THE ENGINE ACCORDING TO THE SAFETY INSTRUCTIONS OUTLINED HERE AND INSERTED THROUGHOUT THE TEXT. ANYONE WHO USES THIS PRODUCT MUST READ THE INSTRUCTIONS AND BE FAMILIAR WITH THE CONTROLS.



#### WARNING

WARNING INDICATES A HAZARD WHICH, IF NOT AVOIDED, COULD RESULT IN DEATH OR SERIOUS INJURY TO PERSONNEL AND/OR PROPERTY DAMAGE.



#### CAUTION

CAUTION INDICATES YOUR EQUIPMENT CAN BE DAMAGED IF THE SAFETY INSTRUCTIONS THAT FOLLOW THIS SIGNAL WORD ARE NOT OBEYED.



#### IMPORTANT

INDICATES HELPFUL INFORMATION FOR PROPER ASSEMBLY, OPERATION, OR MAINTENANCE OF YOUR EQUIPMENT.



#### WARNING

##### CALIFORNIA PROPOSITION 65 WARNING

ENGINE EXHAUST FROM THIS PRODUCT CONTAINS CHEMICALS KNOWN TO THE STATE OF CALIFORNIA TO CAUSE CANCER, BIRTH DEFECTS, OR OTHER REPRODUCTIVE HARM.



#### WARNING

YOU MUST READ, UNDERSTAND AND COMPLY WITH ALL SAFETY AND OPERATING INSTRUCTIONS IN THIS MANUAL BEFORE ATTEMPTING TO SETUP AND OPERATE YOUR MACHINE.

FAILURE TO COMPLY WITH ALL SAFETY AND OPERATING INSTRUCTIONS CAN RESULT IN LOSS OF MACHINE CONTROL, SERIOUS PERSONAL INJURY TO YOU AND/OR BYSTANDERS, AND RISK OF EQUIPMENT AND PROPERTY DAMAGE. THE TRIANGLE IN THE TEXT SIGNIFIES IMPORTANT CAUTIONS OR WARNINGS WHICH MUST BE FOLLOWED.



### Intended Use / Foreseeable Misuse

This is a motorized earth auger that drills into soil. It is pedestrian controlled. It has a petrol-fuelled internal combustion engine that powers the auger blades. It shall not be used for any other purpose.

## GENERAL SAFETY RULES

- Read, understand, and follow all instructions on the machine and in the manual(s). Be thoroughly familiar with the controls and the proper use of the machine before starting.
- Use this equipment for its intended purpose only.
- Familiarize yourself with all of the safety and operating decals on this equipment and on any of its attachments or accessories.
- Do not put hands or feet near or under rotating parts.
- Only allow responsible individuals who are familiar with the instructions to operate the machine. Do not allow children to operate this machine. Do not allow adults to operate the machine without proper instruction.
- Thoroughly inspect the area where the machine is to be used and remove all foreign objects. Your equipment can propel small objects at high speed causing personal injury or property damage. Stay away from breakable objects, such as house windows, automobile, greenhouses, etc.
- Wear appropriate clothing such as a long-sleeved shirt or jacket. Also wear long trousers or slacks. Do not wear shorts. Never wear sandals, sneakers, or open shoes, and never operate the machine with bare feet.
- Do not wear loose clothing or jewelry. They can get caught in moving parts. Always keep hands, feet, hair and loose clothing away from any moving parts on engine and machine.
- Always wear safety goggles or safety glasses with side shields when operating the machine to protect your eyes from foreign objects which can be thrown from the unit. Always wear a protective hearing device.
- Always wear work gloves and sturdy footwear. Wear footwear that will improve footing on slippery surfaces. Leather work shoes or short boots work well for most people. These will protect the operator's ankles and shins from small sticks, splinters, and other debris.
- It is advisable to wear protective headgear to prevent the possibility of being struck by small flying particles, or being struck by low hanging branches, twigs, or other objects which may be unnoticed by the operator.
- Do not operate the machine without proper guards or other safety protective devices in place.
- See manufacturer's instructions for proper operation and installation of accessories. Only use accessories approved by the manufacturer.
- Operate only in daylight or good artificial light.
- Do not operate product when fatigued or under the influence of alcohol, drugs or other medication which can cause drowsiness or affect your ability to operate this machine safely.
- Watch for traffic when operating near, or when crossing roads.
- If the equipment should start to vibrate abnormally, stop the engine (motor), disconnect the spark plug wire and prevent it from touching the spark plug. Check immediately for cause. Vibration is generally a warning of trouble. If the noise or vibrations of the machine increase, stop immediately and perform an inspection.
- Never leave the machine unattended when the engine is running.
- Regularly inspect the machine. Make sure parts are not bent, damaged or loose. Keep all screws, nuts and bolts tight.
- Temperature of muffler and nearby areas may exceed 150° F (65° C). Allow muffler and engine areas to cool before touching. Never pick up or carry the machine while the engine is running.
- Prolonged exposure to noise and vibration from gasoline engine-powered equipment should be avoided. Take intermittent breaks and/or wear ear protection from engine noise as well as heavy work gloves to reduce vibration in the hands.
- Do not transport the machine from one place to another with the engine running.
- When moving the packaged machine, always do so with a partner.
- Check local regulations for age restrictions on use of this machine.

## PRODUCT-SPECIFIC SAFETY RULES

- Do not drill above underground utilities, including water lines, gas lines, electric cables, or pipes. Do not operate the auger in soil with large rocks and foreign objects which can damage the equipment.
- After striking a foreign object, stop the engine. Remove the wire from the spark plug. Inspect the auger for damage. If damaged, repair before starting and operating the auger.
- The blades of the auger should not rotate when the engine is idling. If it does rotate when engine is idling, contact customer service for instructions.
- If an object becomes lodged in the auger, turn engine off, remove the wire from the spark plug and secure, allow to cool before attempting to remove the foreign object.
- The earth blade is very sharp. Use extreme caution when drilling a hole or replacing the blade.
- Do not carry the earth auger unit between holes with the engine running.

 **WARNING**

ENGINES GIVE OFF CARBON MONOXIDE, AN ODORLESS, COLORLESS, POISON GAS. CARBON MONOXIDE MAY BE PRESENT EVEN IF YOU DO NOT SMELL OR SEE ANY ENGINE EXHAUST. BREATHING CARBON MONOXIDE CAN CAUSE NAUSEA, FAINTING OR DEATH, IN ADDITION TO DROWSINESS, DIZZINESS AND CONFUSION.

IF YOU EXPERIENCE ANY OF THESE SYMPTOMS, SEEK FRESH AIR AND MEDICAL ATTENTION IMMEDIATELY.

**ENGINE SAFETY PRECAUTIONS**

If your product comes with a separate engine manual, be sure to read and follow all safety and warning precautions outlined there, in addition to any in this manual.

**Preventing Carbon Monoxide Poisoning**

- Always start and run engine outdoors. Do not start or run engine in an enclosed area, even if doors or windows are open.
- Never try to ventilate engine exhaust indoors. Carbon monoxide can reach dangerous levels very quickly.
- Never run engine outdoors where exhaust fumes may be pulled into a building.
- Never run engine outdoors in a poorly ventilated area where the exhaust fumes may be trapped and not easily taken away. (Examples include: in a large hole or areas where hills surround your working area.)
- Never run engine in an enclosed or partially enclosed area. (Examples include: buildings that are enclosed on one or more sides, under tents, car ports or basements.)
- Always run the engine with the exhaust and muffler pointed in the direction away from the operator.
- Never point the exhaust muffler towards anyone. Bystanders should always be a safe distance from the operation of the engine and its attachments.
- Do not change the engine governor settings or over-speed the engine.

**Gasoline Fires and Handling Fuel Safely**

Use extra care in handling gasoline and other fuels. They are flammable and vapors are explosive.

- When storing extra fuel be sure that it is in an appropriate container and away from any fire hazards.
- Prevent fire and explosion caused by static electric discharge. Use only nonmetal, portable fuel containers approved by the Underwriter's Laboratory (U.L.) or the American Society for Testing & Materials (ASTM).

 **CAUTION**

HOT GASES ARE A NORMAL BY-PRODUCT OF A FUNCTIONING CATALYTIC CONVERTER. FOLLOW ALL SAFETY INSTRUCTIONS TO PREVENT BURNS AND FIRES.

**DO NOT ALTER/MODIFY ENGINE:**

NEVER ALTER OR MODIFY THE ENGINE FROM THE FACTORY. SERIOUS INJURY OR DEATH MAY OCCUR IF ENGINE IS MODIFIED OR ALTERED.

WHEN WORKING ON OR REPLACING PARTS FOR THE ENGINE OR PRODUCT, YOU MUST ALWAYS DISCONNECT SPARK PLUG WIRE FROM THE SPARK PLUG AND KEEP IT AWAY FROM THE SPARK PLUG.

- Always fill fuel tank outside in a well ventilated area. Never fill your fuel tank with fuel indoors. (Examples include: basement, garage, barn, shed, house, porch, etc.) Never fill tank near appliances with pilot lights, heaters, or other ignition sources. If the fuel has to be drained, this should be done outdoors. The drained fuel should be stored in a container specifically designed for fuel storage or it should be disposed of carefully.
- Never remove the fuel cap or add fuel with the engine running. Stop engine and allow to cool before filling.
- Never drain fuel from engine in an enclosed area.
- Always wipe up excess (spilled) fuel from engine before starting. Clean up spilled fuel immediately. If fuel is spilled, do not start the engine but move product and fuel container from area. Clean up spilled fuel and allow to evaporate and dry after wiping and before starting.
- Allow fuel fumes/vapors to escape from the area before starting engine.
- Test the fuel cap for proper installation before starting and using engine.
- Always run the engine with fuel cap properly installed on the engine.
- Never smoke while refilling engine fuel tank or while operating the unit.

- Do not store engine with fuel in fuel tank indoors. Fuel and fuel vapors are highly explosive.
- During storage, screw down gas cap vent screw tightly if equipped.
- Never pour fuel from engine fuel tank.
- Never siphon fuel by mouth to drain fuel tank.
- Always have an adult fill the fuel tank and never allow children to fill the engine.
- Never allow an adult or anyone under the influence of drugs or alcohol to fill engine.
- When storing gasoline or equipment with fuel in the tank, store away from furnaces, stoves, water heaters or other appliances that have a pilot light or other ignition source because they can ignite gasoline vapors.

## **BURNS AND FIRES**

The muffler, muffler guard and other parts of the engine become extremely hot during the operation of the engine. These parts remain extremely hot after the engine has stopped.

### **Prevention of Burns and Fires**

- Never remove the muffler guard from the engine.
- Never touch the muffler guard because it is extremely hot and will cause severe burns.
- Never touch parts of the engine that become hot after operation.
- Always keep materials and debris away from muffler guard and other hot parts of the engine to avoid fires.

## **CHILDREN AND BYSTANDERS**

Tragic accidents can occur if the operator is not alert to the presence of children and/or bystanders. Never assume that others will remain where you last saw them.

- Keep the area of operation clean of all persons, especially small children and pets. Keep children under the watchful care of a responsible adult.
- Be alert and turn machine off if children enter the area.
- Before and while moving backwards, look behind and down for small children.
- Never allow children to operate the machine.

## **SERVICE**

- Always stop the engine whenever you leave the equipment, before cleaning, repairing or inspecting the unit. Engine should be turned off and cool, spark plug wire must be removed from spark plug before any repairs or adjustments are attempted. Never make adjustments or repairs with the engine (motor) running. Disconnect the spark plug wire, and keep the wire away from the plug to prevent accidental starting. Remove the ignition key if equipped with an electric start.
- Always wear eye protection when you make adjustments or repairs.
- Keep all nuts and bolts tight and keep equipment in good condition.
- Never tamper with safety devices. Check their proper operation regularly.
- When servicing or repairing the machine, do not tip the machine over or up unless specifically instructed to do so in this manual. Service and repair procedures can be done with the machine in an upright position. Some procedures will be easier if the machine is lifted on a raised platform or working surface.
- To reduce fire hazard, keep machine free of grass, leaves, or other debris build-up. Clean up oil or fuel spillage. Allow machine to cool before storing.
- Stop and inspect the equipment if you strike an object. Repair, if necessary, before restarting.
- Clean and replace safety and instruction decals as necessary.
- To guard against engine over-heating, always have engine debris filter mounted and clean.
- Inspect machine before storage. When not in use, disconnect spark plug lead and store indoors in a dry place locked or otherwise inaccessible to children.
- Use only original equipment parts from Earthquake, including all nuts and bolts.

## SAFETY DECALS (9800BCE EUROPEAN MODELS ONLY)

This auger unit has been designed and manufactured to provide you with the safety and reliability you would expect from an industry leader in outdoor power equipment manufacturing.

Reading this manual and the safety instructions it contains will provide you with the necessary basic knowledge to operate this equipment safely and effectively. Several safety labels on the powerhead remind you of this important information while you are operating the unit.

These important safety labels are illustrated below, and are shown here to help familiarize you with the location and content of the safety messages you will see as you perform normal drilling operations. Please review these labels now. If you have any questions regarding their meaning or how to comply with these instructions, reread the complete safety instruction text on the preceding pages, or contact your local dealer.

Should any of the safety labels become unreadable because of being worn, faded, or otherwise damaged during the use of your auger, please use the part number information provided to order a replacement label from your local authorized dealer.

The safety labels are easily applied, and will act as a constant visual reminder to you, and others who may use the equipment. Follow the safety instructions necessary for safe, effective operation of your auger.

ARDISAM, INC.   
1160 8th Avenue | Cumberland, WI 54829 | USA

Serial No.

Model: 9800BCE Type: Earth Auger  
Mass: 10.89 kg  
Max. Operating Speed: 8500 rpm  
L<sub>PA</sub> (dBA): 100 L<sub>WA</sub> (dBA): 108.4

SERIAL NUMBER LOCATION DECAL



Part No. 10502  
HOT SURFACE DECAL



Part No. 10508  
NOISE LEVEL DECAL



Part No. 10505  
SAFETY PRECAUTIONS DECAL  
- Read entire manual before operating product  
- Wear eye and hearing protection  
- Throttle speed control

## FEATURES (9800B/9800BCE SHOWN)

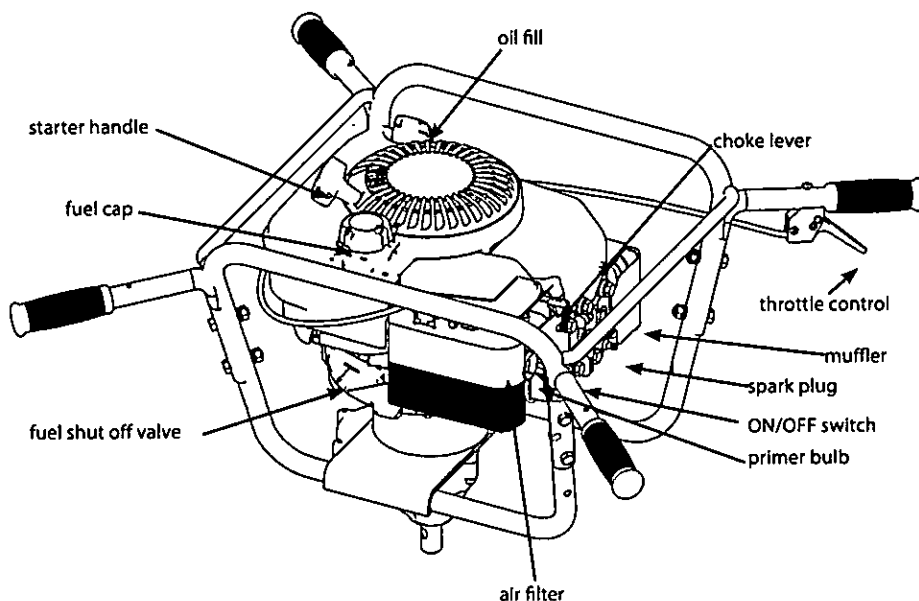

## ASSEMBLY

### UNPACK POWERHEAD

1. Carefully lift the powerhead out of the box, remove any packing material and cut any ties.

### TOOLS REQUIRED

- Two (2) 9/16" Wrenches

### ASSEMBLY INSTRUCTIONS (SEE FIGURE 1)

1. Place the handle bar grip onto the frame.
2. Secure with two 5/16-18 x 1 1/2 inch bolts.
3. Install spring lock washers and lock nuts and tighten. Repeat for all handles..
4. Insert the output shaft of the transmission in the open end of the Flex Coil Shock Top.
5. Line up the bolt holes through the Flex Coil Shock Top and the output shaft of the transmission.
6. Install the 3/8-16 x 1.5 inch bolt through the bolt hole.
7. Install the 3/8-16 BI-Way locknut on the bolt.
8. Using two 9/16 inch wrenches, tighten the lock nut and bolt.

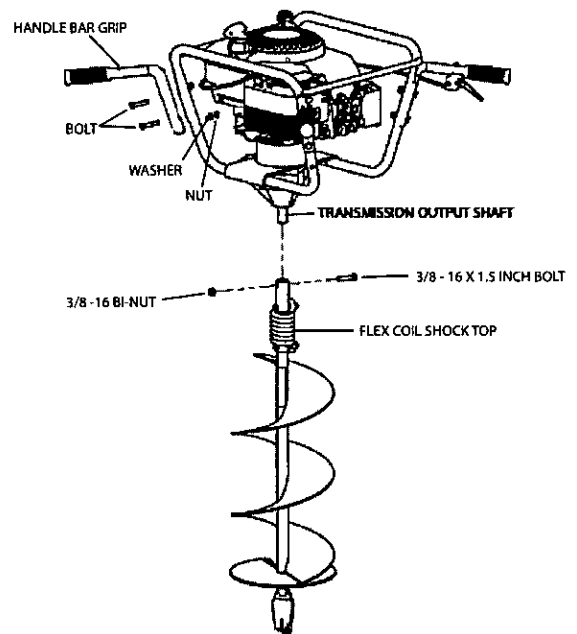

FIGURE 1



## OPERATION

### PRE-START CHECKLIST

1. Read and understand the operator's manual that came with your unit and the engine.
2. Fill oil sump or check oil level. Check oil level often during engine break-in.
3. Fill fuel tank. Use unleaded, regular gasoline.
4. Be sure spark plug wire is attached to spark plug.

### PREPARING ENGINE FOR STARTING

#### TO CHECK THE OIL

1. Check the engine oil level with the engine stopped and in a level position.
2. Remove the oil filler cap/dipstick and wipe it clean.
3. (On the Briggs & Stratton Engine) Insert the oil filler cap/dipstick into the oil filler neck and retighten.  
(On the Honda Engine:) Insert the oil filler cap/dipstick into the oil filler neck but do not screw it in.
4. Remove the dipstick to check the oil level.
5. If the oil level is near or below the lower limit mark on the dipstick, fill with the recommended oil to the upper limit mark. Do not overfill.
6. Reinstall the oil filler cap/dipstick.

#### FUEL RECOMMENDATIONS

Use clean, fresh, regular unleaded gasoline with a minimum of 87 octane/ 87 AKI (91 RON).

- These engines are certified to operate on unleaded gasoline. Unleaded gasoline produces fewer engine and spark plug deposits and extends exhaust system life.
- Never use stale or contaminated gasoline or an oil/gasoline mixture. Avoid getting dirt or water in the fuel tank.
- Occasionally, you may hear a light "spark knock" or "pinging" (metallic rapping noise) while operating under heavy loads. This is no cause for concern.
- If spark knock or pinging occurs at a steady engine speed, under a normal load, change gasoline brands. If spark knock or pinging persists, see an authorized servicing dealer.
- Gasoline with up to 10% Ethanol (Gasohol) is acceptable.

Do not use unapproved gasolines such as E15 and E85.

#### FILLING FUEL TANK

1. Shut-off engine and allow engine to completely cool before refilling the gas tank.
2. Move to a well-ventilated area, outdoors, away from flames and sparks.

### CAUTION

**DO NOT START YOUR EARTH AUGER UNIT UNTIL YOU HAVE READ THE ENGINE MANUAL THAT CAME WITH YOUR ENGINE, AND THE "WARNINGS AND SAFETY PRECAUTIONS" SECTION IN THIS MANUAL. IF YOU HAVE READ THESE, FOLLOW THE STEPS TO START YOUR EARTH AUGER UNIT. ALWAYS PERFORM PRE-START CHECKLIST BEFORE STARTING THE ENGINE.**

**IT IS RECOMMENDED THAT THE EARTH AUGER UNIT NOT BE TILTED AT MORE THAN A 30 DEGREE ANGLE FROM THE UPRIGHT POSITION. FAILURE TO DO SO CAN CAUSE FUEL AND/OR OIL LEAKAGE.**

### CAUTION

**NEVER ADD GAS WHEN ENGINE IS RUNNING OR HOT FROM OPERATION. NEVER FILL THE TANK INDOORS. DO NOT SMOKE WHEN FILLING FUEL TANK.**

**NEVER FILL FUEL TANK COMPLETELY. FILL TANK TO 1/2" BELOW BOTTOM OF FILLER NECK TO PROVIDE SPACE FOR FUEL EXPANSION. WIPE ANY FUEL SPILLAGE FROM ENGINE AND EQUIPMENT BEFORE STARTING ENGINE.**

**DO NOT HOLD THROTTLE LEVER WIDE OPEN WHILE STARTING. LOSS OF CONTROL OF POWERHEAD/AUGER COULD RESULT.**

**NEVER RUN ENGINE INDOORS OR IN ENCLOSED, POORLY VENTILATED AREAS. ENGINE EXHAUST CONTAINS CARBON MONOXIDE, AN ODORLESS AND DEADLY GAS.**

**KEEP HANDS, FEET, HAIR AND LOOSE CLOTHING AWAY FROM ANY MOVING PARTS ON ENGINE AND EQUIPMENT.**

**TEMPERATURE OF MUFFLER AND NEARBY AREAS MAY EXCEED 150° F. AVOID THESE AREAS.**

**BEFORE STORING UNIT, DISCONNECT SPARK PLUG WIRE FROM SPARK PLUG AND ATTACH IT TO RETAINING POST.**

**NEVER STORE ENGINE WITH FUEL IN TANK INDOORS OR IN ENCLOSED, POORLY VENTILATED AREAS, WHERE FUEL FUMES MAY REACH AN OPEN FLAME, SPARK OR PILOT LIGHT.**

### IMPORTANT

**NEVER MIX OIL WITH GASOLINE IN A FOUR CYCLE ENGINE.**

3. Clean debris from area around the gas cap.
4. Loosen gas cap slowly. Place the cap on a clean, dry surface.
5. Carefully add fuel without spilling.
6. Do not fill gas tank completely full; allow space for fuel to expand.
7. Immediately replace gas cap and tighten. Wipe off spilled fuel and allow to dry before starting engine.

## IMPORTANT OPERATION NOTES

1. Read engine manual and follow instructions for fuel type, starting, etc.
2. The clutch will transfer maximum power after about two hours of normal operation. During this break-in period clutch slippage may occur. The clutch should be kept free of oil or other moisture for efficient operation.
3. The earth auger unit should be operated no more than 20 degrees in any direction during continuous use, and limited to 30 degrees intermittently. This is recommended for adequate lubrication and fuel delivery.
4. When digging in heavy soil, lift the earth auger unit out of the hole once for every one foot of depth.
5. Never run engine indoors. Exhaust fumes are deadly.
6. Do not use an earth auger in ice.
7. Drill holes without placing excessive body weight on the unit. The auger operates most efficiently with a shaving action caused by the weight of the unit itself.

## STARTING AND STOPPING ENGINE

### TO START ENGINE:

1. Check the engine oil level.
2. Make sure engine drive controls, if equip are disengaged.
3. Open fuel shut-off valve.
2. Flip the on/off switch to **ON** position.
3. Move choke lever to the **CHOKE** position.  
**NOTE: Do not use the choke to restart a warm engine after a short shut down.**
4. Grasp starter handle and pull rope out, slowly, until it pulls slightly harder. Then pull rope with a rapid full arm stroke. Let rope return to starter slowly.
5. When engine fires or starts running, gradually move the choke lever back to the **RUN** position.

### TO STOP ENGINE:

1. Flip the on/off switch to the **OFF** position.
2. Close fuel shut-off valve.

## **WARNING**

**MAKE SURE THE UNIT IS IN A STABLE POSITION BEFORE PULLING THE STARTER HANDLE.**

**WHEN THE UNIT STARTS TO FIRE OR RUN, RELEASE THE THROTTLE CONTROL MOMENTARILY WITH YOUR RIGHT HAND AND RETURN YOUR LEFT HAND TO THE HANDLEBAR POSITION TO MAINTAIN CONTROL AND STABILITY OF THE UNIT WITH BOTH HANDS.**

## **CAUTION**

**ALWAYS HANDLE FUEL IN A WELL VENTILATED AREA, OUTDOORS, AWAY FROM FLAMES OR SPARKS.**

**DO NOT START ENGINE IF FUEL IS SPILLED. WIPE OFF EXCESS FUEL AND ALLOW TO DRY. REMOVE ENGINE FROM AREA TO AVOID SPARKS.**

**TO PREVENT ACCIDENTAL STARTING; ENGINE MUST BE TURNED OFF AND COOL, AND SPARK PLUG WIRE MUST BE REMOVED FROM SPARK PLUG BEFORE CHECKING AND ADJUSTING ENGINE OR EQUIPMENT.**

**DO NOT OPERATE AUGER BEFORE READING THE ENGINE MANUAL PROVIDED IN THE PARTS PACKET.**

**ALWAYS WEAR A PROTECTIVE HEARING DEVICE.**

**IF AUGER IS MOUNTED TO ENGINE, ALL SAFETY GUARDS MUST BE SECURELY ON TO AVOID SERIOUS INJURY.**

**STARTER ROPE CAN CAUSE AN UNANTICIPATED JERK TOWARDS ENGINE. PLEASE FOLLOW INSTRUCTIONS TO AVOID INJURY.**

**IF ENGINE FAILS TO START AFTER PERFORMING THE STARTING PROCEDURES, PLEASE CONTACT OUR CUSTOMER SERVICE DEPARTMENT AT 800-345-6007.**

**NEVER LEAVE ENGINE RUNNING WHILE UNATTENDED. TURN OFF AFTER EVERY USE.**

**NEVER CARRY POWERHEAD AND AUGER BETWEEN HOLES WHILE ENGINE IS RUNNING.**

## **IMPORTANT**

**ENGINE CAN OVERHEAT AND BECOME DAMAGED IF DEBRIS BLOCKS THE COOLING FINS OR RECOIL HOUSING.**

**NEVER RUN ENGINE WITHOUT COMPLETE AIR CLEANER INSTALLED ON ENGINE.**

## MAINTENANCE AND STORAGE

### POWER AUGER MAINTENANCE

1. The gear case has 4 oz. of grease installed at the factory. It is recommended that once a year the gear case be split and the grease level checked. Add grease only if level of grease is below top of the gears. **DO NOT OVERFILL.**
2. Keep all screws, nuts, and bolts tight.
3. For cold weather operation, store the unit in a cool environment. Transferring the unit from a warm to a cold place can cause the build up of harmful condensation.
4. If blade performance decreases, turn unit off and disconnect spark plug wire. Carefully inspect cutting edge of blade for any signs of wear. If blades show any of these signs, they need to be sharpened or replaced.
5. Always allow muffler to cool before filling fuel tank.
6. When storing for over one month, use gas stabilizer in fuel.
7. Do not fill gas tank indoors or when engine is running or is hot.

### ENGINE MAINTENANCE

Please read your engine manual and observe these recommendations to extend the life of your engine. Your engine manual provides detailed information and a maintenance schedule for performing the following tasks:

1. Check oil level every five (5) operating hours and before each use.
2. Change oil after first five (5) operating hours and every 50 operating hours thereafter, more often if operated in extremely dusty or dirty conditions. Change oil while engine is still warm from recent running.
3. Frequently remove dirt and debris from cooling fins, air intake screen, levers and linkage. This will help ensure adequate cooling and correct engine speed.
4. Clean air cleaner every 25 hours of operation, replace yearly.
5. Check spark plug yearly or every 100 operating hours.
6. Check engine and auger often for loose nuts and bolts.

Good maintenance is essential for safe, economical, and trouble-free operation. It will also help reduce air pollution. To help you properly care for your engine, read your engine manual and pay close attention to the maintenance schedule, routine inspection procedures, and simple maintenance procedures.

Other service tasks that are more difficult, or require special tools, are best handled by professionals and are normally performed by a technician or other qualified mechanic.

### CAUTION

#### **TO PREVENT ACCIDENTAL STARTING:**

**ENGINE MUST BE SHUT-OFF AND COOL, AND SPARK PLUG WIRE MUST BE REMOVED FROM SPARK PLUG BEFORE CHECKING AND ADJUSTING ENGINE OR EQUIPMENT.**

**CHECK AUGER OFTEN FOR LOOSE NUTS AND BOLTS. KEEP THESE ITEMS TIGHTENED.**

**NEVER STORE ENGINE WITH FUEL IN THE TANK INSIDE A BUILDING. POTENTIAL SPARKS MAY BE PRESENT FOR IGNITION OF FUEL AND FUEL VAPORS.**

**ANY MAINTENANCE AND REPAIR ON THE ENGINE AND AUGER MUST ALWAYS BE DONE BY AN ADULT.**

**ENGINE MUST BE SHUT-OFF, COOL, AND SPARK PLUG WIRE REMOVED BEFORE ANY REPAIR OR MAINTENANCE CAN BE DONE.**

**Maintenance, replacement or repair of the emissions control devices and systems may be performed by any non-road engine repair establishment or individuals. However, items must be serviced by an authorized dealer to obtain "no charge" emissions control service.**

The maintenance schedule applies to normal operating conditions. If you operate your engine under unusual conditions, such as sustained high-load or high-temperature operation, or use in unusually wet or dusty conditions, consult your servicing dealer for recommendations applicable to your individual needs and use.

### TRANSPORTING YOUR EARTH AUGER

1. Never transport engine inside an enclosed space or vehicle. Fuel or fuel vapors may ignite causing serious injury or death.
2. If fuel is present in the fuel tank, transport in an open vehicle in an upright position.
3. If an enclosed vehicle must be used, remove gas into an approved red fuel container. **DO NOT siphon by mouth.**
4. Run engine to use up the fuel in the carburetor and fuel tank. Always run engine in a well ventilated area.
5. Wipe away any spilled fuel from engine and earth auger. Allow to dry.

## LONG-TERM STORAGE

If your earth auger will not be used for more than one month, prepare it for long-term storage.

Follow the steps below to prepare your earth auger unit for storage. Read your engine manual for detailed instructions on preparing the engine for storage.

1. Run with gas stabilizer in fuel. The screen in the carburetor will glaze shut if gas stabilizer is not used before storage.
2. Drain the fuel system. Run the engine until it stops.
3. Change oil.
4. Remove spark plug, pour one (1) ounce of clean engine oil into spark plug hole. Cover hole with a rag. Pull starter handle slowly several times to distribute oil. Install spark plug. **Do not connect spark plug wire.**
5. Clean entire earth auger unit.
6. Store your earth auger unit in a clean, dry building that is inaccessible to children.

## TROUBLESHOOTING AND REPAIR

At Earthquake, we build quality and durability into the design of our products; but no amount of careful design by us, and careful maintenance by you, can guarantee a repair-free life for your Earthquake powerhead. Most repairs will be minor, and easily fixed by following the suggestions in the troubleshooting guide in this manual.

The troubleshooting guide will help you pinpoint the causes of common problems and identify remedies.

For more complicated repairs, you may want to rely on your retailer, an authorized service center or Earthquake. A parts breakdown is located toward the end of this manual.

We will always be glad to answer any questions you have, or help you find suitable assistance. To order parts or inquire about warranty, call or e-mail us using the contact information found under "Ordering Replacement Parts".

### CAUTION

**TO AVOID INJURY OR DEATH, NEVER SIPHON FUEL BY MOUTH.**

**NEVER STORE EARTH AUGER WITH FUEL IN THE GAS TANK INSIDE AN ENCLOSED AREA OR BUILDING.**

**MAINTENANCE AND REPAIR ON THE ENGINE AND AUGER MUST ALWAYS BE DONE BY AN ADULT.**

**ENGINE MUST BE SHUT-OFF, COOL, AND SPARK PLUG WIRE REMOVED BEFORE ANY REPAIR OR MAINTENANCE CAN BE DONE.**

### CAUTION

**DO NOT STORE EARTH AUGER UNIT WITH FUEL IN TANK INDOORS OR IN ENCLOSED, POORLY VENTILATED AREAS, WHERE FUEL FUMES MAY REACH AN OPEN FLAME, SPARK, PILOT LIGHT OR AN IGNITED OBJECT. DRAIN FUEL OUTDOORS AWAY FROM ANY IGNITION SOURCES. USE ONLY APPROVED FUEL CONTAINERS.**

**FOR LONG TERM STORAGE: CLOSE FUEL SHUT-OFF VALVE AND STORE EARTH AUGER UNIT IN AN UPRIGHT POSITION. FAILURE TO DO SO CAN CAUSE OIL LEAKAGE OVER A PROLONGED PERIOD.**

## ORDERING REPLACEMENT PARTS

Parts can be obtained from the store where the auger was purchased or direct from the factory. To order parts visit [www.getearthquake.com](http://www.getearthquake.com) or call 1-800-345-6007.

For other general questions, you can e-mail us at [info@getearthquake.com](mailto:info@getearthquake.com).

**IN CASE OF A SERVICE PROBLEM, DO NOT SEND EARTH AUGER UNIT BACK TO RETAILER. CONTACT EARTHQUAKE AT 800-345-6007.**

Please include the following information with your order:

- 1) Part numbers
- 2) Part description
- 3) Quantity
- 4) Model number and serial number

## TROUBLESHOOTING GUIDE

While normal care and routine maintenance will extend the life of your auger powerhead, prolonged or constant use may eventually require that service be performed to allow it to continue operating properly. The troubleshooting guide below lists the most common problems, causes and remedies.

### CAUTION

**PRACTICE SAFETY AT ALL TIMES. ENGINE MUST BE TURNED OFF AND ALLOWED TO COOL, AND SPARK PLUG WIRE MUST BE DISCONNECTED BEFORE ATTEMPTING ANY MAINTENANCE OR REPAIR.**

PROBLEM	POSSIBLE CAUSE	REMEDY/ACTION
Engine will not start	1. Power switch off	1. Flip switch to <b>ON</b> position
	2. Spark plug wire disconnected	2. Connect spark plug wire to spark plug
	3. Fuel valve closed	3. Open fuel valve
Engine runs rough, floods during operation	1. Dirty air cleaner	1. Clean or replace air cleaner
	2. Carburetor out of adjustment	2. Take to authorized Briggs & Stratton/Honda service center
	3. Fuel valve closed	3. Open fuel valve
Engine is hard to start	1. Stale fuel	1. Drain old fuel and replace with fresh. Use gas stabilizer at end of season
	2. Spark plug wire loose	2. Make sure spark wire is securely attached to spark plug
	3. Dirty carburetor	3. Clean carburetor, use gas stabilizer, new gas can
Engine misses or lacks power	1. Clogged fuel tank	1. Remove and clean
	2. Clogged air cleaner	2. Clean or replace
	3. Improper carburetor adjustment	3. Take to authorized Briggs & Stratton/Honda service center
	4. Spark plug dirty, improper gap, or wrong type	4. Replace spark plug and adjust gap
Auger turns at idle	1. Idle speed too high	1. Adjust idle speed lower
	2. Broken clutch spring	2. Replace both springs
Auger turns, but has no power	1. Carburetor out of adjustment	1. Take to authorized Briggs & Stratton/Honda service center
	2. Broken transmission	2. Replace transmission
	3. Worn clutch shoes	3. Replace clutch
	4. Worn engine lower seal	4. Take to authorized Briggs & Stratton / Honda service center
Auger cuts slowly	1. Damaged point	1. Replace fishtail point
	2. Worn out blade	2. Replace blade
Engine runs, then quits	1. Screen in carburetor plugged	1. Clean screen, use gas stabilizer, clean gas can
	2. Fuel valve closed	2. Open fuel valve

**NOTE: Please see the engine manual for any engine issues.**

## ILLUSTRATED PARTS BREAKDOWN

9800B/9800BCE/9800H

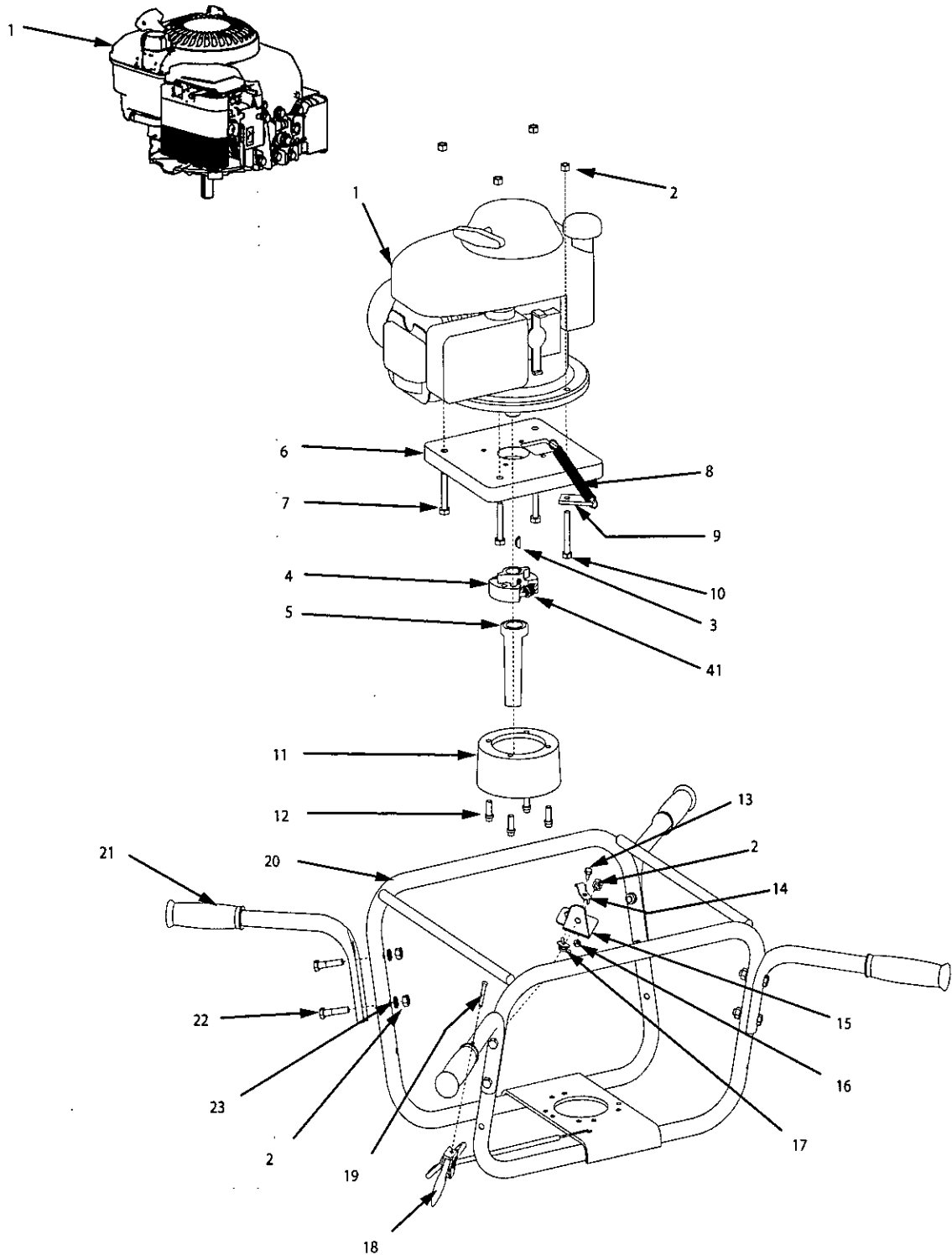

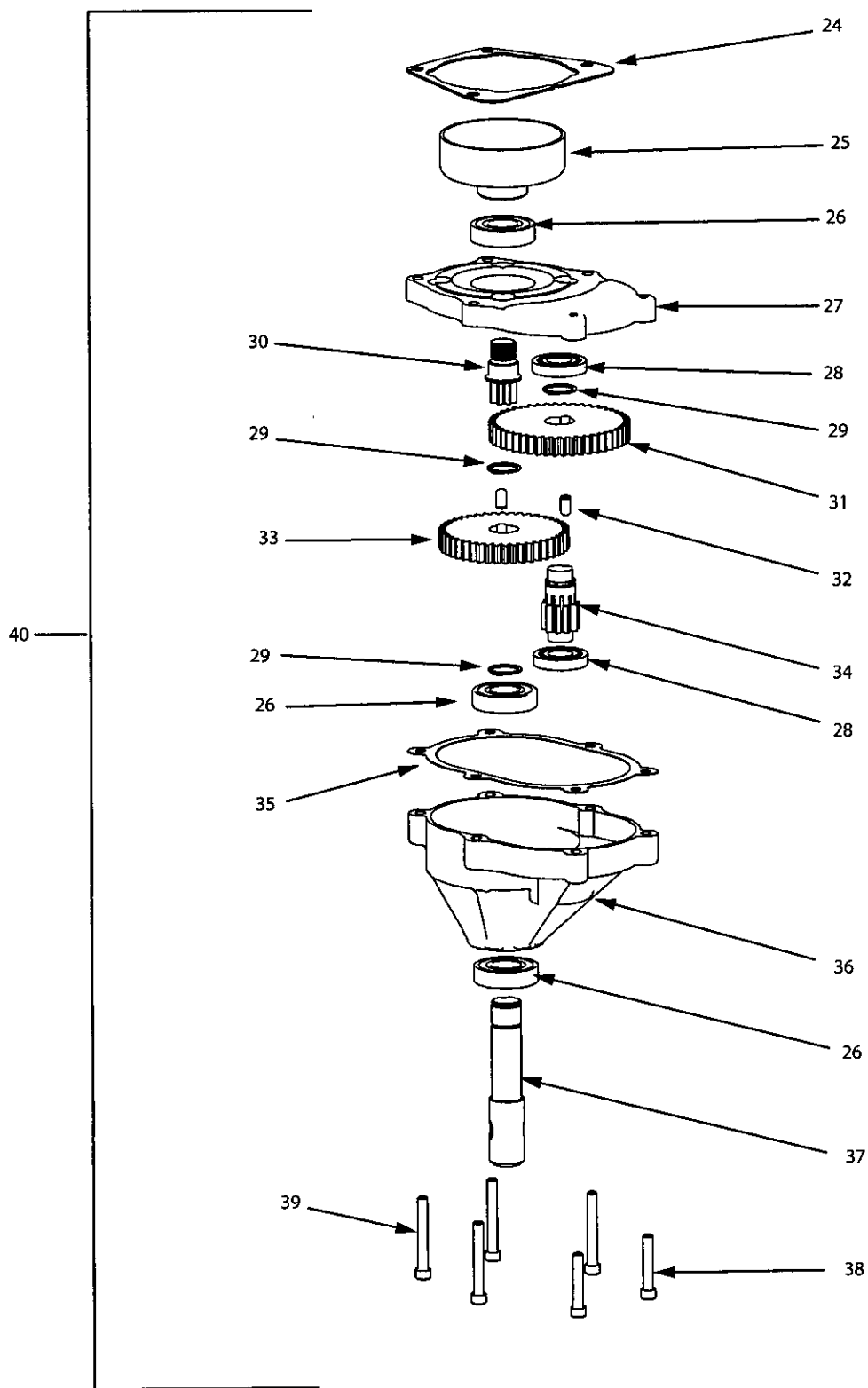

**9800B/9800BCE/9800H EARTH AUGER ILLUSTRATED PARTS BREAKDOWN**

ITEM NO.	PART NO.	DESCRIPTION	QTY.
1	*	ENGINE, BRIGGS 675 SERIES (9800B)	1
	*	ENGINE, BRIGGS 675 SERIES CE (9800BCE)	1
	*	ENGINE, 160CC HONDA (9800H)	1
2	60G56	NUT, LOCK, (5/16-18 BI-WAY) (9800B, 9800BCE)	8
	60G56	NUT, LOCK, (5/16-18 BI-WAY) (9800H MODEL)	12
3	WK6	KEY, WOODRUFF (#6, 5/32 X 5/8")	1
4	9825	ROTOR CENTRIFUGAL CLUTCH	1
5	9822	BEARING, BALL (R14-2RS) (9800H ONLY)	1
6	9840	PLATE ADAPTER, MOUNTING RING (9800H ONLY)	1
7	1423	BOLT, (5/16-18X 2" HHCS GR5) (9800H ONLY)	3
8	9832	SPRING, THROTTLE CONTROL (9800H ONLY)	1
9	53664	TAB, THROTTLE (9800H ONLY)	1
10	48300	BOLT, (5/16 X-18 X 2 1/4" HHCS GR5) (9800H ONLY)	1
11	9837A	MOUNT RING COMPLETE 9800 SERIES	1
12	420	BOLT, (5/16-24 X 3/4" PFC5)	4
13	1B5810	BOLT, (5MM X 0.8 X 10MM HH) (9800H ONLY)	1
14	53596A	CLAMP, CABLE (YELLOW ZINC) (9800H ONLY)	1
15	9841	BRACKET, THROTTLE CABLE CLAMP (9800H ONLY)	1
16	1N58	NUT, (5MM X 0.8 X 10MM HH) (9800H ONLY)	1
17	60G70	SWITCH, TOGGLE, (ON-OFF) (9800H ONLY)	1
18	4819	TRIGGER ASSEMBLY, LONG THROW (INCLUDES P/N 4814) (9800H ONLY)	1
	9805A	CABLE (NO TRIGGER) (9800H ONLY)	1
	9801	CABLE THROTTLE W/TRIGGER (9800B/9800BCE ONLY)	1
19	4814	BOLT, (10-24 X 1 1/4" PHILLIPS TRUSS HEAD) (9800H ONLY)	1
20	9819	WELDMENT, FRAME 9800	1
21	9827	HANDLE AND THROTTLE GRIP 9800	4
22	503	BOLT (5/16-18 X 1-1/2 HH)	8
23	504	LOCKWASHER SPRING (5/16")	8
24	3004149	SHIM, (9800 TRANSMISSION TOP)	1
25	9016	CLUTCH DRUM, (3" THREADED) (9800H ONLY)	1
	9018	CLUTCH DRUM, (3" THREADED SHORT) (9800B, 9800BCE ONLY)	1

ITEM NO.	PART NO.	DESCRIPTION	QTY.
26	8922	BEARING, BALL (R12 DOUBLE LIP)	3
27	75300	KIT, GEAR CASE, UPPER HALF (INCLUDES BEARINGS 8922, 8923, SHIM 3004149, AND GASKET 8919)	1
28	8923	BEARING, BALL R10	2
29	8924	RING, SNAP EXTERNAL (3/4")	3
30	9814	GEAR, PINION (7 TOOTH THREADED)	1
31	8914	GEAR, (48 TOOTH HARD)	1
32	8915	DOWEL PIN, STEEL (1/4 X 1/2")	2
33	8912	GEAR, (44 TOOTH 3/4 HOLE)	1
34	9214A	GEAR, (10 TOOTH CLUSTER PINION, HT)	1
35	8919	GASKET, POWERHEAD TRANSMISSION	1
36	75600	KIT, GEAR CASE, LOWER HALF, (INCLUDES BEARINGS 8922, 8923, AND POWERHEAD TRANSMISSION GASKET 8919)	1
37	8913	SHAFT, OUTPUT (7/8")	1
38	8929	BOLT, (1/4-20 X 1 1/2" SHCS)	2
39	8935	BOLT, (1/4-20 X 2 1/2" SHCS)	4
40	9800BTRANKIT	KIT, TRANSMISSION ASSEMBLY (9800B/9800BCE ONLY)	1
	98005	KIT, TRANSMISSION ASSEMBLY (9800H ONLY)	1
41	9020A	SPRING, CENTRIFUGAL CLUTCH	2

\*Contact your local engine dealer for parts and service. Contact information can be found in the engine manual accompanying this product.



## AUGER PARTS ILLUSTRATED PARTS BREAKDOWN

EA2F, EA3F

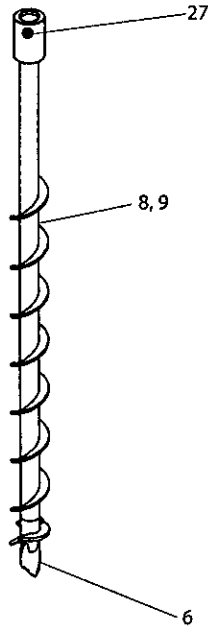

EA4F

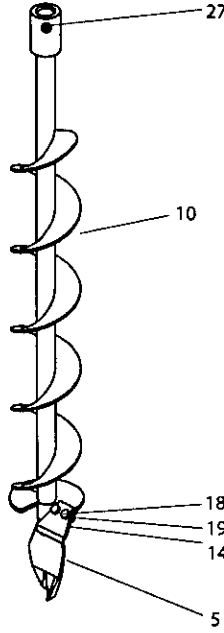

EA6F

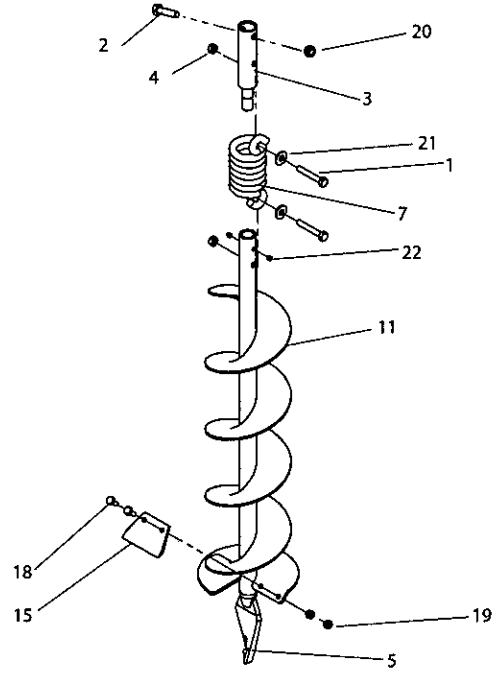

EA8F

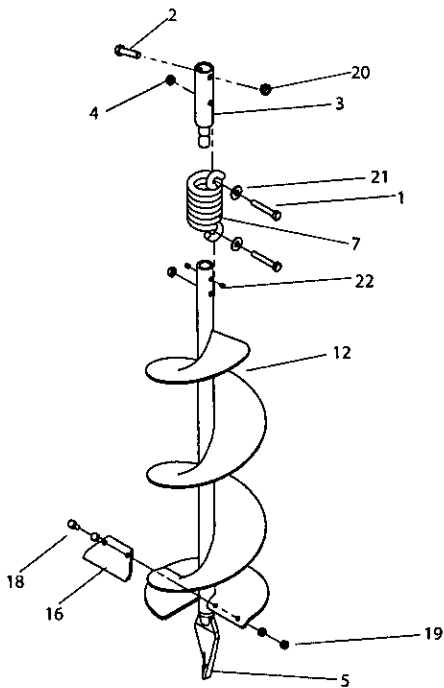

EA10F

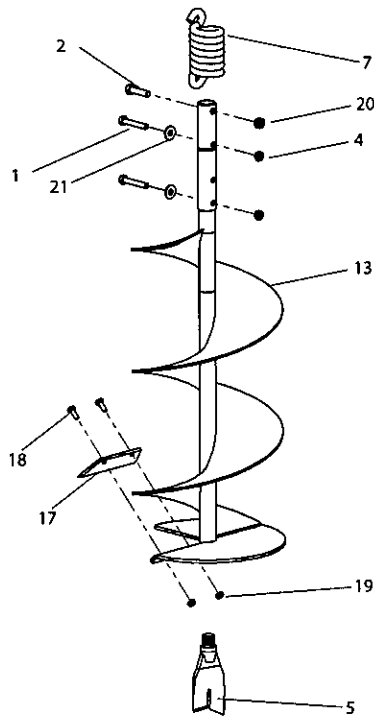

EA12F, EA14F

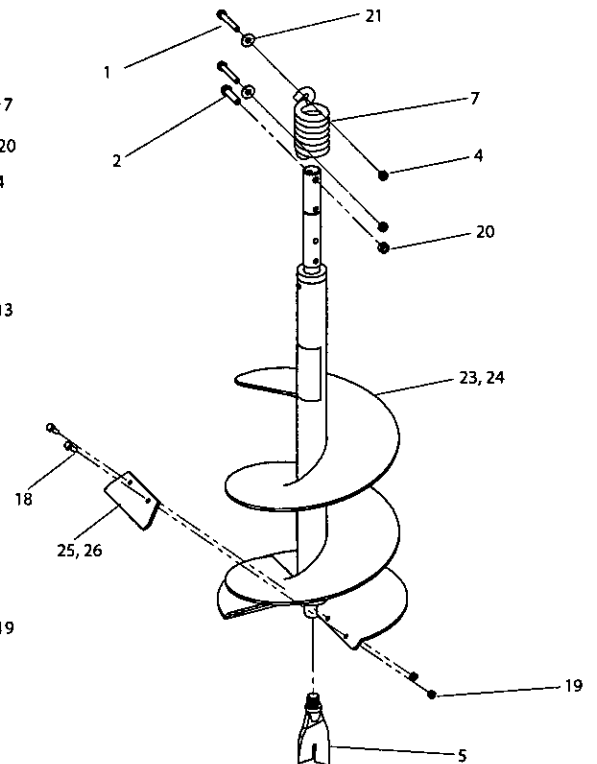

### AUGER ILLUSTRATED PARTS BREAKDOWN

ITEM NO.	PART NO.	DESCRIPTION	QTY.
1	1423	BOLT-HHCS, 5/16-18 X 2", GRADE 5 (auger shock spring)	2
2	1433	BOLT-HHCS, 3/8-16 X 1-1/2" (auger to powerhead)	2
3	53684	SHOCK TOP 1-PC (used on 6" and 8" earth augers)	1
4	60G56	NUT-HEX 2-WAY REVERSIBLE LOCKNUT, 5/16-18	2
5	8958HD	FISHTAIL POINT (used on 4" or larger earth auger)	1
6	8970	EARTH POINT (used on 2" & 3" earth auger)	1
7	8980	SHOCK SPRING (Used on 6" and larger earth augers)	1
8	EA2F	EARTH AUGER, 2" W/FISHTAIL POINT	1
9	EA3F	EARTH AUGER, 3" W/FISHTAIL POINT	1
10	EA4F	EARTH AUGER, 4" W/FISHTAIL POINT	1
11	EA6F	EARTH AUGER, 6" W/FISHTAIL POINT	1
12	EA8F	EARTH AUGER, 8" W/FISHTAIL POINT	1
13	EA10F	EARTH AUGER, 10" W/FISHTAIL POINT	1
14	EB4	EARTH BLADE, 4" (includes EBOLT & ENUT)	1
15	EB6	EARTH BLADE, 6" (includes EBOLT & ENUT)	1
16	EB8	EARTH BLADE, 8" (includes EBOLT & ENUT)	1
17	EB10	EARTH BLADE, 10" (includes EBOLT & ENUT)	1
18	EBOLT	BOLT-HEX, 1/4-28 X 5/8", GRADE 5 (earth blade to auger)	2
19	ENUT	NUT-NYLOC, 1/4-28	2
20	2104	NUT HEX LOCKING, 3/8-16	2
21	WF516	WASHER-FLAT, 5/16"	2
22	715	SET SCREW 1/4-20 X 1/4 SPCP BLK OXIDED	2
23	EA12F	EARTH AUGER, 12" W/FISHTAIL POINT	1
24	EA14F	EARTH AUGER, 14" W/FISHTAIL POINT	1
25	EB12	EARTH BLADE, 12" (includes EBOLT & ENUT)	1
26	EB14	EARTH BLADE, 14" (includes EBOLT & ENUT)	1
27	8955	BOLT 3/8-16 X 1-1/4 SHCS	1
<b>ITEMS NOT SHOWN</b>			
--	EXT12	DEPTH EXTENSION, 12"	1
--	EXT18	DEPTH EXTENSION, 18"	1
--	EB6HD	HEAVY DUTY EARTH BLADE, 6" (includes EBOLT & ENUT)	1
--	EB8HD	HEAVY DUTY EARTH BLADE, 8" (includes EBOLT & ENUT)	1
--	EB10HD	HEAVY DUTY EARTH BLADE, 10" (includes EBOLT & ENUT)	1
--	9811	SWITCH, ON/OFF (Not Shown)	1

**WARRANTY TERMS AND CONDITIONS****PRODUCT WARRANTY: 1-YEAR LIMITED WARRANTY**

Ardisam, Inc. (Ardisam) warrants the product(s) under a one-year limited warranty to be free from defects in the material or workmanship or both for a period not exceeding twelve consecutive months from the date of original purchase by the first retail consumer or first commercial end user. "Consumer use" means personal recreational use by a retail consumer. "Commercial use" or "commercial application" means all other uses, including use for commercial, income producing or rental purposes. Once a product has experienced commercial use, it shall thereafter be considered as a commercial use product for the purpose of this warranty. This warranty applies to the original owner that provides a proof of purchase. The warranty is not transferable. The warranty period begins on the date of purchase by the first retail consumer or commercial end user, and continues for the twelve month consecutive period thereafter. Any unit used in a commercial application is covered for a period of 90 days after purchase by the first commercial end user. For the warranty to be valid, the product must be registered online, or the warranty card must be filled out and received by Ardisam, within 30 days of purchase. Ardisam shall not be obligated to ship any repair or replacement product to any location outside of the United States of America or Canada.\*

***For replacement parts, phone 800-345-6007.***

\*This warranty policy applies only to products which have not been subjected to negligent use, misuse, uses other than those indicated in the product's operator's manual, alteration, accident, use of unauthorized parts, failure to perform periodic maintenance as specified in product's operator's manual, normal wear and tear, use of unauthorized parts or repairs performed at unauthorized service centers. There is no other expressed warranty. Implied warranties, including those of merchantability and fitness for a particular purpose, are limited to one year from purchase, or to the extent permitted by law. All other implied warranties are excluded. Liability for incidental or consequential damages are excluded to the extent exclusion is permitted by law. Ardisam does not assume, and does not authorize any other person to assume for Ardisam, any liability in connection with the sale of Ardisam products. **To be at "No Charge," warranty work must be sent directly to and performed by Ardisam or an Ardisam Authorized Warranty Service Facility.** To obtain warranty service and/or replacement instructions, contact the Ardisam Customer Service Department at 800-345-6007. If you choose to ship your product to Ardisam for warranty repair, you must first have prior approval from Ardisam by calling the Ardisam Customer Service Department for a return material authorization number (RMA#). Under these circumstances, all items must be shipped prepaid. Ardisam will at no charge, repair or replace, at the discretion of Ardisam, any defective part which satisfies all conditions stated above. Ardisam retains the right to change models, specifications and price without notice. Ardisam shall not be obligated to ship any repair or replacement product to any location outside of the United States of America or Canada.

***NOTE: For detailed information on this product's Engine Warranty, refer to the warranty section in the Engine Manual that accompanies this Operator's Manual.***

17649-REV1

Earthquake™, Division of Ardisam, Inc.  
1160 Eighth Avenue; P.O. Box 666  
Cumberland, Wisconsin 54829  
800-345-6007 · Fax (715) 822-4180  
E-mail: info@getearthquake.com

## Free Manuals Download Website

<http://myh66.com>

<http://usermanuals.us>

<http://www.somanuals.com>

<http://www.4manuals.cc>

<http://www.manual-lib.com>

<http://www.404manual.com>

<http://www.luxmanual.com>

<http://aubethermostatmanual.com>

Golf course search by state

<http://golfingnear.com>

Email search by domain

<http://emailbydomain.com>

Auto manuals search

<http://auto.somanuals.com>

TV manuals search

<http://tv.somanuals.com>