

Instruction Manual

PN 51-2081C/T/rev.B

April 2003

Model 2081C/T

Conductivity Microprocessor Transmitter



ESSENTIAL INSTRUCTIONS

READ THIS PAGE BEFORE PROCEEDING!

Rosemount Analytical designs, manufactures, and tests its products to meet many national and international standards. Because these instruments are sophisticated technical products, you must properly install, use, and maintain them to ensure they continue to operate within their normal specifications. The following instructions must be adhered to and integrated into your safety program when installing, using, and maintaining Rosemount Analytical products. Failure to follow the proper instructions may cause any one of the following situations to occur: Loss of life; personal injury; property damage; damage to this instrument; and warranty invalidation.

- Read all instructions prior to installing, operating, and servicing the product. If this Instruction Manual is not the correct manual, telephone 1-800-654-7768 and the requested manual will be provided. Save this Instruction Manual for future reference.
- If you do not understand any of the instructions, contact your Rosemount representative for clarification.
- Follow all warnings, cautions, and instructions marked on and supplied with the product.
- Inform and educate your personnel in the proper installation, operation, and maintenance of the product.
- Install your equipment as specified in the Installation Instructions of the appropriate Instruction Manual and per applicable local and national codes. Connect all products to the proper electrical sources.
- To ensure proper performance, use qualified personnel to install, operate, update, program, and maintain the product.
- When replacement parts are required, ensure that qualified people use replacement parts specified by Rosemount. Unauthorized parts and procedures can affect the product's performance and place the safe operation of your process at risk. Look alike substitutions may result in fire, electrical hazards, or improper operation.
- Ensure that all equipment doors are closed and protective covers are in place, except when maintenance is being performed by qualified persons, to prevent electrical shock and personal injury.

NOTE

The Model 2081C/T Two-wire transmitter is certified for use in areas requiring intrinsic safety area by FM, CSA, and CENELEC. However, the CENELEC certification requires that a Model 2081C/T used with contacting sensors be certified separately from those using inductive (toroidal) sensors. The type of sensor must be specified with the order for a CENELEC certified transmitter.

Since this decision is required prior to shipment, the instruction manual covers both configurations. However, if the transmitter is reconfigured in the field, it may not meet CENELEC certification conditions.

About This Document

This manual contains instructions for installation and operation of the Model 2081C/T Conductivity Transmitter. The following list provides notes concerning all revisions of this document.

<u>Rev. Level</u>	<u>Date</u>	<u>Notes</u>
A	7/01	This is the initial release of the product manual. The manual has been reformatted to reflect the Emerson documentation style and updated to reflect any changes in the product offering.
B	4/03	Updated CE certification

Emerson Process Management

Rosemount Analytical Inc.

2400 Barranca Parkway
Irvine, CA 92606 USA
Tel: (949) 757-8500
Fax: (949) 474-7250

<http://www.raihome.com>



EMERSON[™]
Process Management

MODEL 2081C/T CONDUCTIVITY MICROPROCESSOR TRANSMITTER

TABLE OF CONTENTS

Section	Title	Page
1.0	INSTALLATION	1
1.1	Unpacking and Inspection.....	1
1.2	Mechanical Installation.....	1
1.3	Wiring.....	1
1.4	Fault Mode and Security Jumpers.....	2
1.5	Calibration and Setup.....	3
1.6	Hazardous Locations — Explosion Proof Installation.....	3
1.7	Hazardous Locations — Intrinsically Safe Installation.....	3
2.0	DESCRIPTION OF CONTROLS	17
2.1	General.....	17
2.2	Menu Selection	17
2.3	Value Adjustment	17
3.0	RANGE CONFIGURATION	18
3.1	General.....	18
4.0	START UP AND CALIBRATION	19
4.1	General.....	19
4.2	Temperature Calibration.....	19
4.3	Entering the Cell Constant.....	19
4.4	Zeroing the System.....	19
4.5	Initial Loop Calibration.....	19
4.6	Routine Standardization.....	21
4.7	Hold Mold for Maintenance.....	21
4.8	Sensor Maintenance	21
5.0	KEYBOARD SECURITY	22
5.1	Push Button Security.....	22
5.2	Eeprom Security.....	22
6.0	DIAGNOSTICS AND TROUBLESHOOTING.....	23
6.1	General.....	23
6.2	Contact Conductivity Mode Bench Check.....	24
6.3	Toroidal Conductivity Mode Bench Check	25
6.4	Systematic Troubleshooting.....	25
7.0	THEORY OF OPERATION	29
7.1	General.....	29
7.2	Overview	29
8.0	DESCRIPTION AND SPECIFICATIONS.....	31
8.1	Features	31
8.2	Functional Specifications	32
8.3	Performance Specifications	32
8.4	Physical Specifications.....	33
8.5	Recommended Sensors.....	33
8.6	Ordering Information	34
8.7	Accessories.....	34
9.0	RETURN OF MATERIAL.....	36

TABLE OF CONTENTS CONT'D.

LIST OF FIGURES

Figure No.	Title	Page
1-1	Model 2081C/T Dimensional/Mounting Instructions with Power Supply/Loop Signal Wiring	4
1-2	Model 2081C/T Contacting Electrode Wiring	5
1-3	Model 2081C/T Inductive Sensor Wiring	6
1-4	Fault and Security Jumper Locations.....	7
1-5	Sensor To Transmitter Switch Settings	7
1-6	Explosion Proof System Installation Schematic	8
1-7	Intrinsically Safe (BASEEFA) Wiring for Model 2081C	9
1-8	Intrinsically Safe (BASEEFA) Wiring for Model 2081T	11
1-9	Intrinsically Safe (CSA) Wiring for Model 2081C/T	13
1-10	Intrinsically Safe (FM) Wiring for Model 2081C/T	15
3-1	Menu Description	17
5-1	Jumper Locations	22
6-1	Bench Check (Contact Sensor)	26
6-2	Bench Check (Toroidal Sensor)	26
6-3	Troubleshooting Flow Chart	28
7-1	Block Diagram	29
8-1	Load/Power Supply Requirements.....	32
8-2	Model 275 HART® Communication Menu Tree-Model 2081C/T	35

LIST OF TABLES

Table No.	Title	Page
3-1	Sensors used with Model 2081C/T conductivity	18
3-2	Measurement Ranges.....	18
6-1	Diagnostic Messages	23
6-2	Resistance Values (Temperature)	24
6-3	Resistance Values (Conductivity).....	24
6-4	Quick Troubleshooting Guide.....	27
8-1	Local Interference Functions.....	32
8-2	Measurement Ranges.....	32

SECTION 1.0 INSTALLATION

1.1 UNPACKING AND INSPECTION. Inspect the transmitter for shipping damage. If damaged, notify the carrier immediately.

Confirm that all items shown on the packing list are present. Notify Rosemount Analytical if any items are missing.

If the transmitter appears to be in satisfactory condition proceed to Section 1.2.

NOTE

Save the original packing cartons and materials as most carriers require proof of damage due to mishandling.

1.2 MECHANICAL INSTALLATION.

1.2.1 General. The transmitter may be installed in harsh environments. However, it should be installed in an area where sources of extreme temperature fluctuation, vibration and shock are at a minimum or absent. Installation site should:

1. permit the use of the standard cable lengths (unless a junction box is used),
2. be easily accessed by operating and maintenance personnel, and
3. be at least 12 inches (.3 m) from sources of high voltage.

NOTE

Before installing the transmitter, it should be determined whether the Model 275 will be used with the 2081C/T.

1.2.2 Mounting. The transmitter may be mounted on a flat surface using the two threaded mounting holes located on the bottom of the transmitter or through the use of an optional 2-inch pipe/wall mounting bracket, Code 07 (Figure 1-1).

NOTE

The meter may be installed in 90-degree increments for easy viewing. Remove the four screws holding the meter in place and change the meter to the desired angle. Plug in the display and tighten the four screws.

1.3 WIRING. The transmitter is equipped with two 1/2-inch NPT conduit openings, one on each side of the housing. One is for the power supply/signal wiring and the other is for the sensor wiring.

The use of weathertight cable glands or conduit is recommended to prevent moisture from entering the housing. Conduit should be positioned to prevent condensation from draining into the housing. Conduit connections on the transmitter housing should be plugged and sealed to avoid moisture accumulation inside the terminal section of the housing.

CAUTION

If the connections are not sealed, mount transmitter with the electrical housing positioned downward for drainage. Wiring should be installed with a drip loop. The bottom of the drip loop should be lower than the conduit connections or the transmitter housing.

1.3.1 Power Supply/Signal Wiring. It is recommended that the signal wiring be shielded, twisted pairs that are grounded. The best place to ground the loop is at the negative terminal of the power supply. Do not ground the signal loop at more than one point. The transmitter case shall be grounded. The power and signal wiring terminal is TB2 terminals 1 through 4 as shown in either Figures 1-1, 1-2, and 1-3.

Signal or sensor wiring should never be run in the same conduit or open tray as AC power or relay actuated signal cables. Keep signal or sensor wiring at least 12 in. (.3 m) from heavy electrical equipment.

NOTE

For best EMI/RFI protection the power supply/signal cable should be shielded and enclosed in an earth grounded, rigid metal conduit. Connect the cable's outer shield to the ground terminal near TB2, Figure 1-1. The sensor cable should also be shielded. The cable's outer shield shall be connected to the earth ground terminal provided near TB2, Figure 1-1. If the outer shield is braided an appropriate metal cable gland fitting maybe used to connect the braid to earth ground via the instrument case.

A new addition to the suite of tests done to ensure CE compliance is IEC 1000-4-5. This is a surge immunity test that simulates overvoltages due to switching and lightning transients.

In order to meet the requirements of this test, additional protection must be added to the instrument in the form of a Transient Protector such as the Rosemount Model 470D. This is a 3½-inch tube with ½-inch MNPT threads on both ends. Inside the tube are gas discharge and zener diode devices to limit surges to the transmitter from the current loop. No additional protection is needed on the sensor connections.

1.3.2 Sensor Wiring. The sensor wiring terminals are located on the side opposite to the LCD meter. Remove the housing cover to gain access. Pass the sensor cable through the transmitter's conduit opening. Connect the sensor wiring to TB1 terminals 1 through 12 as shown on Figures 1-2 and 1-3.

NOTE

If the standard cable length is not sufficient for the planned installation, the use of a junction box with extension cable is strongly recommended. Do not exceed 250 feet (76m) total cable length from the sensor to the transmitter.

1.3.3 Matching Transmitter to sensor. Switches S4 and S5 are used to normalize the transmitter for Toroidal or contact sensors. See Figure 1-5.

Switches S4 and S5 should both be set to T when Toroidal sensors are installed, C when Contact sensors are installed.

Switches S1 and S2 are used to select the sensitivity range of the LCD. To obtain desired switch settings, multiply the cell constant of the probe being used by the maximum low range value. If the working range of the process is below this calculated value then set both switch to Lo. If the working range of the process is above this calculated value then set both switch to Hi (see table below).

Type Sensor	Maximum Range	Switch Setting
Toroidal	Below 400,000µS x Cell Constant	Both "Lo"
	Above 400,000µS x Cell Constant	Both "Hi"
Contacting	Below 4,000µS x Cell Constant	Both "Lo"
	Above 4,000µS x Cell Constant	Both "Hi"

Sample: Model 142 sensor: .2 (cell constant) x 4,000µS (maximum low range value)= 800µS (calculated value).

1.4 FAULT MODE AND SECURITY JUMPER

1.4.1 General This section describes how to set the jumpers on the CPU board for the following (See Figure 1-4).

1. Output value in fault (alarm) mode
2. Security - Write Disable
3. Security - Push Buttons

CAUTION

The circuit board is electrostatically sensitive. Be sure to observe handling precautions for static-sensitive components.

1.4.2 Fault Mode Output. The default output of the transmitter during a fault condition is determined by the position of the default current output jumper JP3 (refer to Figure 1-4). The output can be set to default either:

- below 4mA - JP3 with jumper.
- above 20mA - JP3 without jumper (factory setting).

Store jumper on one post to prevent misplacing it. See Section 8.0 for corrective actions for fault messages.

Mnemonic	Fault
SLP - FAI L	- 2 point calibration error
AdC - FAI L	- Transmitter electronics failure (A/D converter)
range - LOOP	- Conductivity value outside 4-20 mA range points
TEMP - Lo	- Temperature too low or RTD shorted
TEMP - Hi	- Temperature too high or RTD open

1.4.3 Security. Also explained in Section 6.0. These jumpers are located on the CPU board. See Figure 1-4 for location.

- Disable 2081 push buttons - JP4 without jumper. (Store jumper on one post to prevent misplacing it).
- Enable 2081 push buttons - JP4 with jumper (factory setting).
- Disable all changes to configuration - JP1. Jumper in place disables any (EEPROM or push button) changes.
- Allow changes to configuration - JP1 Jumper on one post only will enable configuration changes.

1.5 CALIBRATION AND SET-UP

Instructions for output current ranging, security set ups, and calibration of sensor temperature, cell constant etc, are contained in Sections 2.0 through 5.0.

1.6 HAZARDOUS LOCATIONS — EXPLOSION PROOF INSTALLATIONS

In order to maintain the explosion proof rating for installed transmitter, the following conditions must be met.

1. Code 67 must be specified when ordering F.M. (Factory Mutual) units.
2. Explosion proof installation must be in accordance with Drawing Number 1400160 (see Figure 1-6).
3. The transmitter enclosure covers must be on hand tight and the threads must not be damaged.

NOTE

These covers seat on rings which serve to provide a dust proof enclosure for Class II and Class III installations.

4. Explosion proof “Y” fittings must be properly installed and plugged with a sealing compound to prevent explosive gases from entering the transmitter. CSA has determined that the transmitter housing is “Factory Sealed”. Installation of “Y” fittings and the use of sealing compound is not required for CSA approved Explosion Proof installations.

NOTE

Do not install sealing compound until all field wiring is completed.

CAUTION

Sealing compound must be installed prior to applying power to the transmitter.

5. If one of the conduit connections on the housing is not used, it must be closed with a threaded metal plug with at least five threads engaged.

1.7 HAZARDOUS LOCATIONS — INTRINSICALLY SAFE INSTALLATIONS

See Figure 1-7 for Model 2081C intrinsically safe installation (BASEEFA). See Figure 1-8 for Model 2081T intrinsically safe installation (BASEEFA). See Figure 1-9 for Model 2081C and 2081T intrinsically safe installation (CSA). See Figure 1-10 for Model 2081C and 2081T intrinsically safe installation (FM).

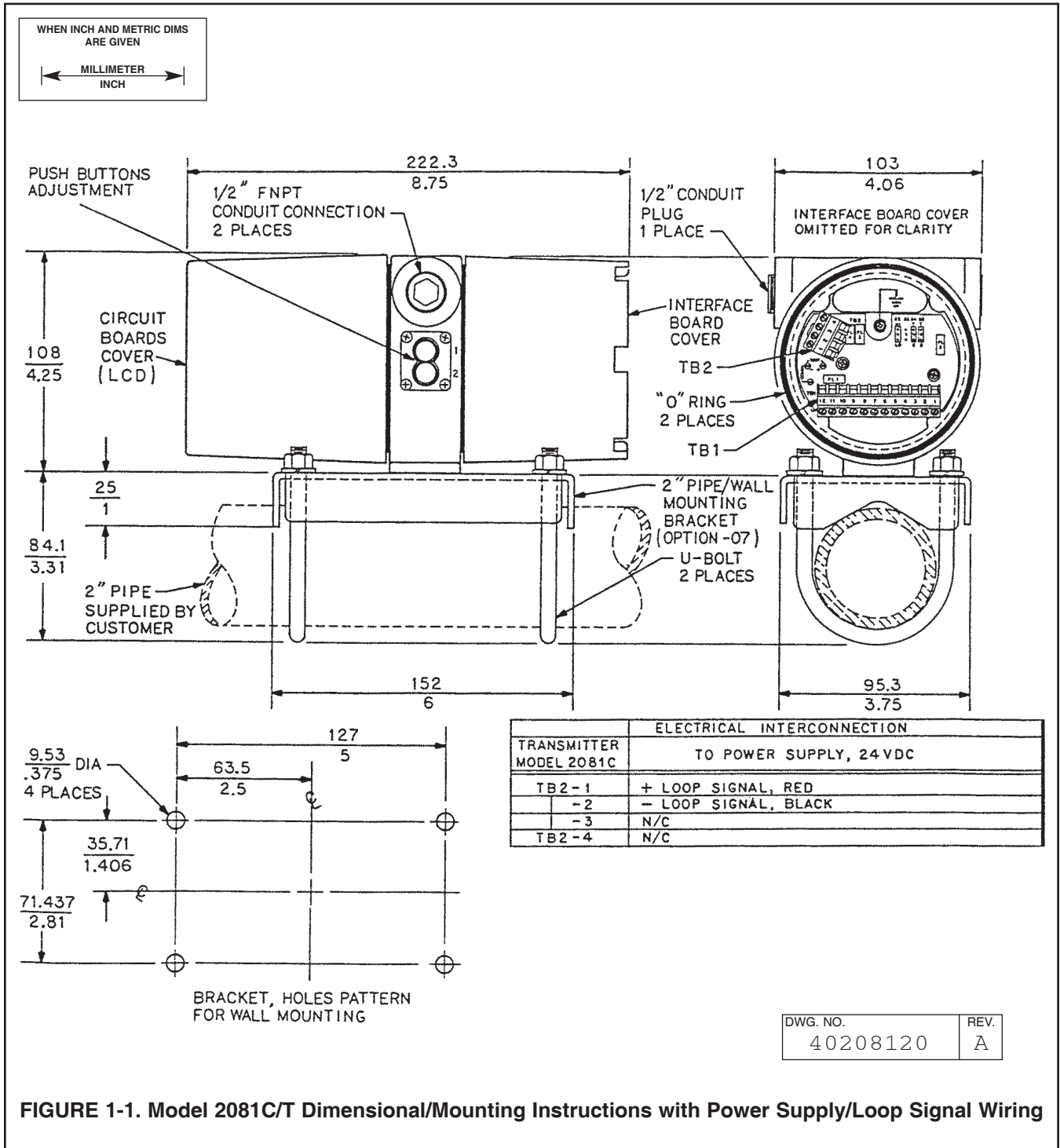
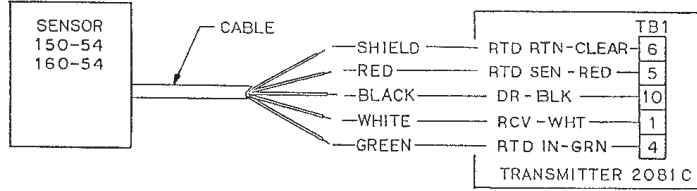
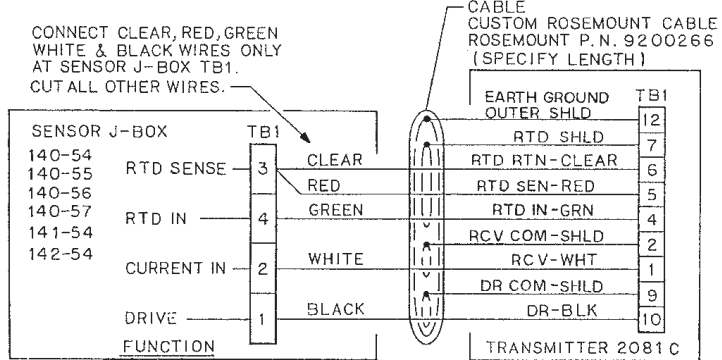
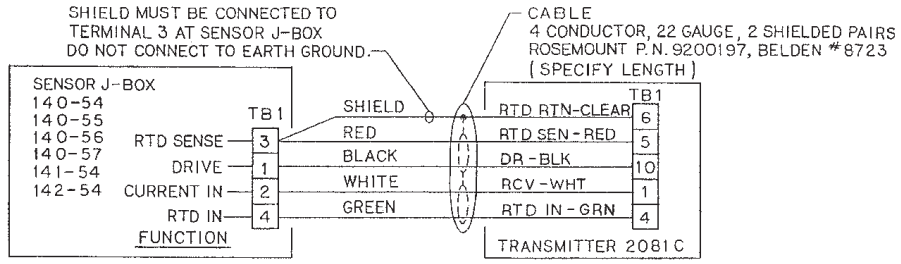
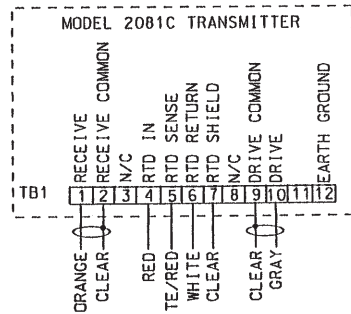
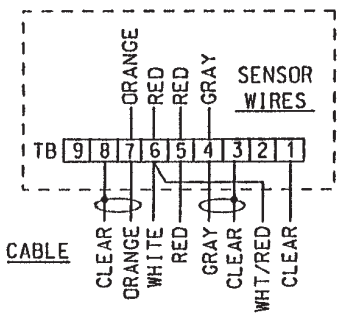
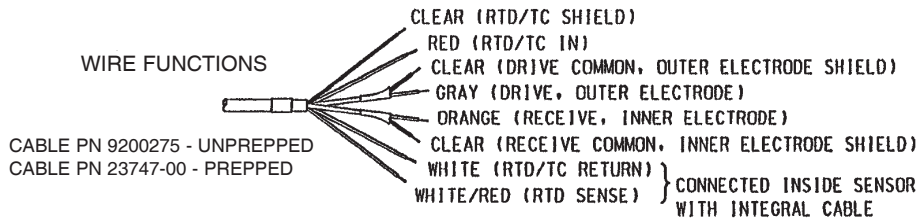

FIGURE 1-1. Model 2081C/T Dimensional/Mounting Instructions with Power Supply/Loop Signal Wiring

WHEN INCH AND METRIC DIMS
ARE GIVEN
MILLIMETER
INCH



CE approved cable for Sensor Models 140, 141, 142, 150, 400, 401, 402, 403, & 404 using cable PN 9200275 or 23747-00



NOTE: TERMINALS IN JUNCTION BOX
ARE NOT NUMBERED.
* OLD MODEL 140 SERIES SENSORS
MAY NOT MATCH THE FIGURE.

NOTE: THE TERMINAL BLOCK CAN BE REMOVED
TO FACILITATE WIRING.

DWG. NO. 40208119	REV. A
----------------------	-----------

FIGURE 1-2. Model 2081C Contacting Electrode Wiring

WHEN INCH AND METRIC DIMS
ARE GIVEN

← MILLIMETER →
← INCH →

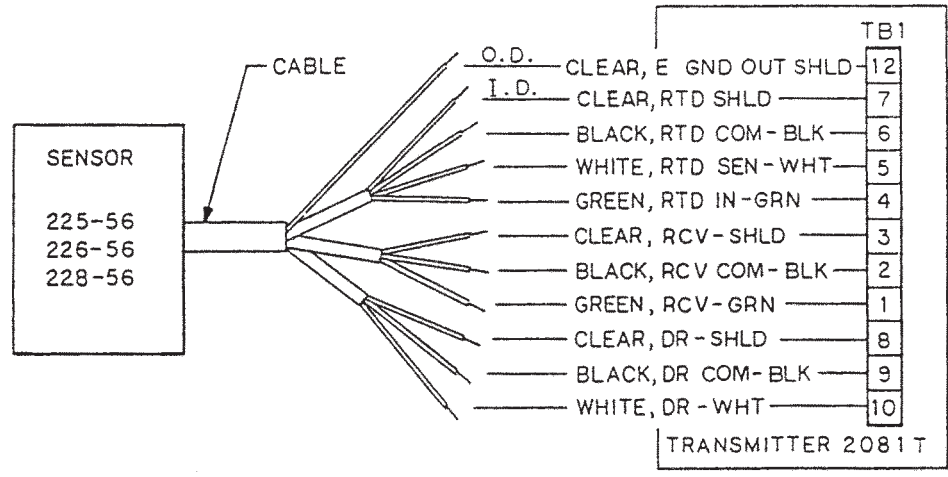
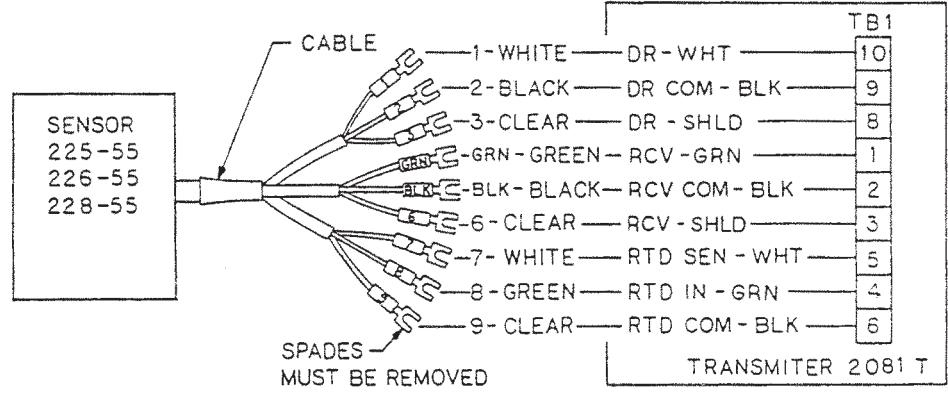
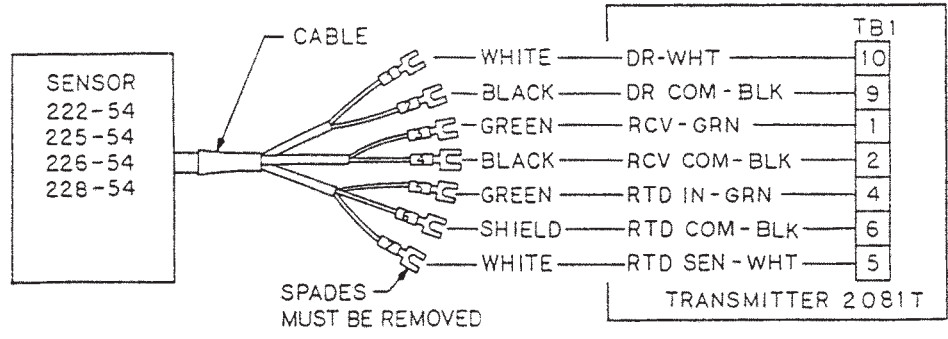

DWG. NO.	REV.
40208106	C

FIGURE 1-3. Model 2081T Inductive Sensor Wiring

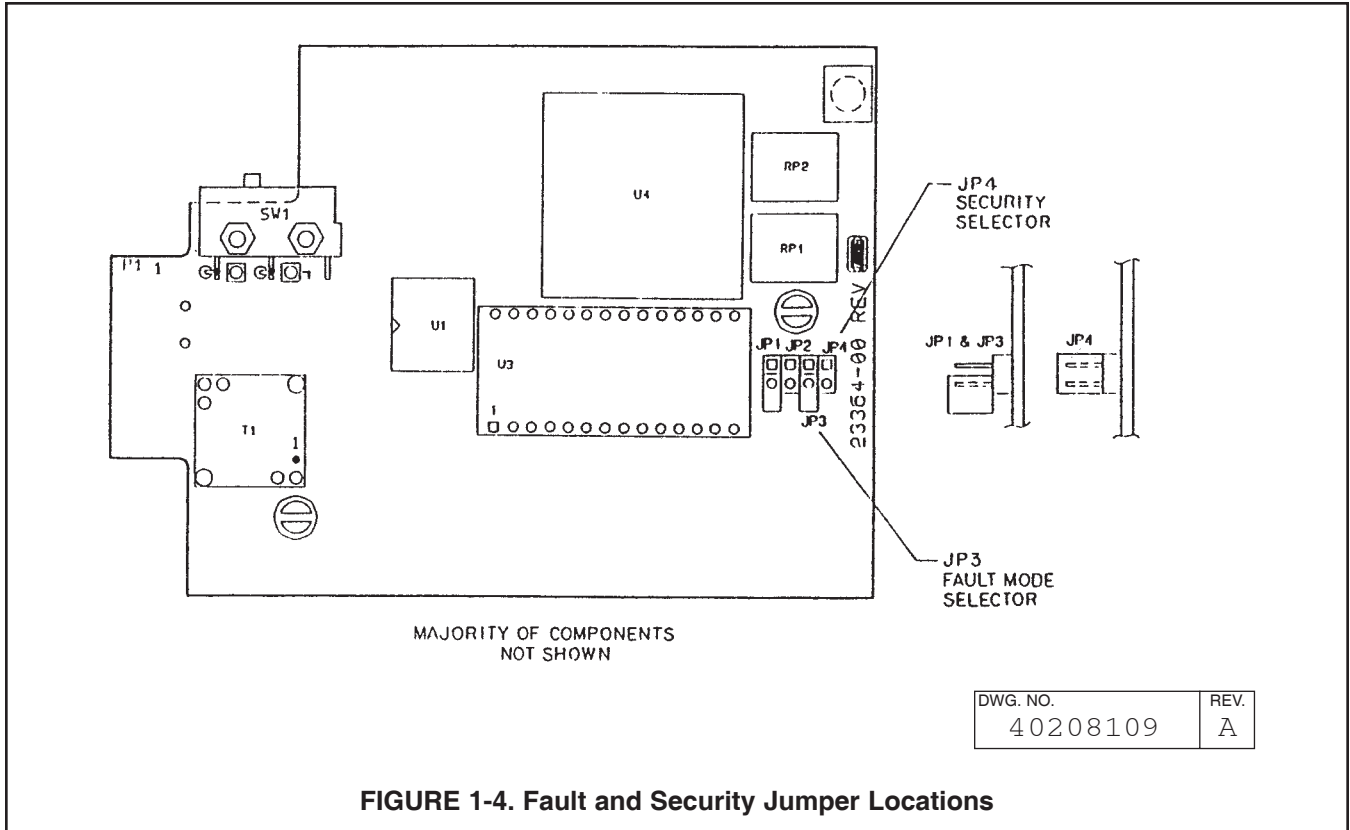

FIGURE 1-4. Fault and Security Jumper Locations

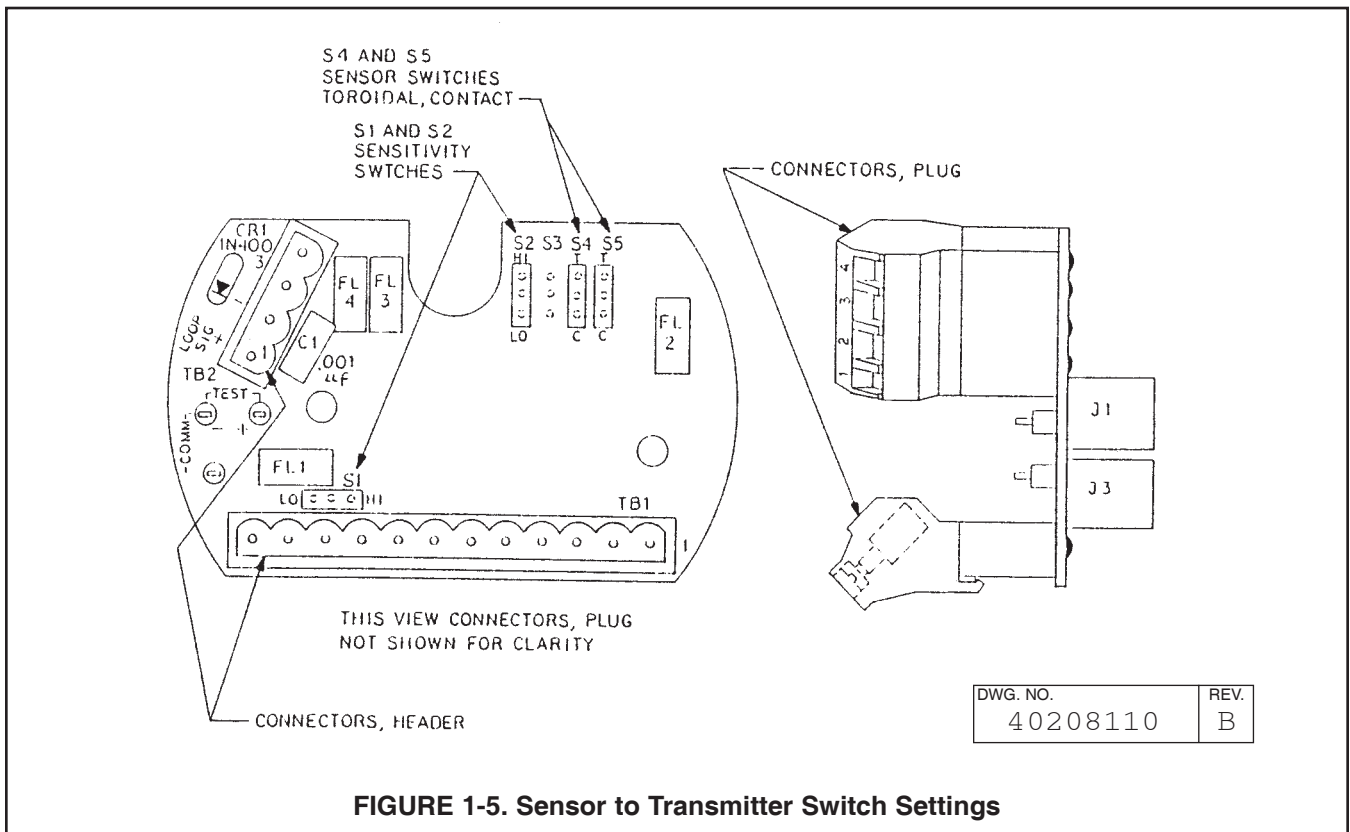
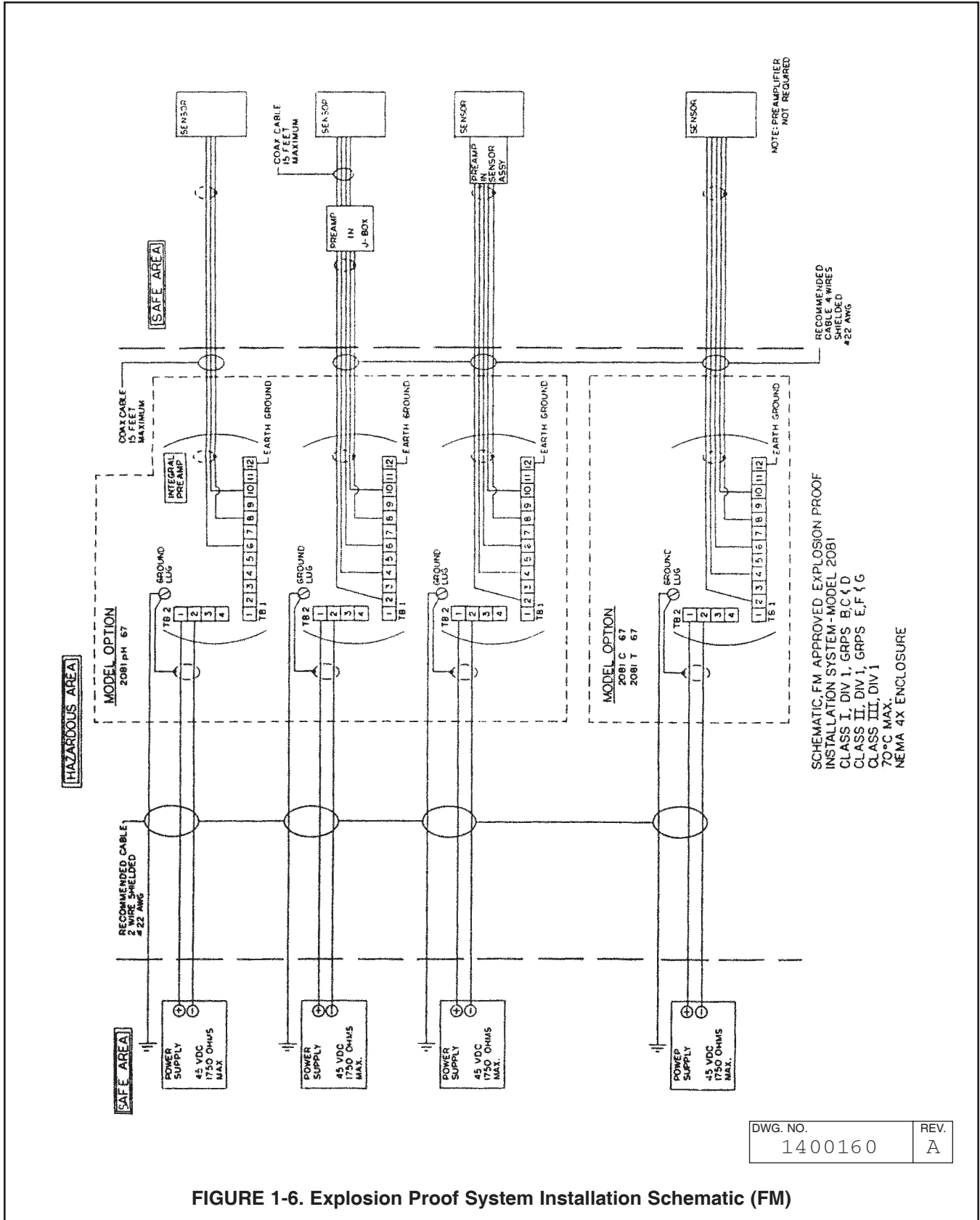
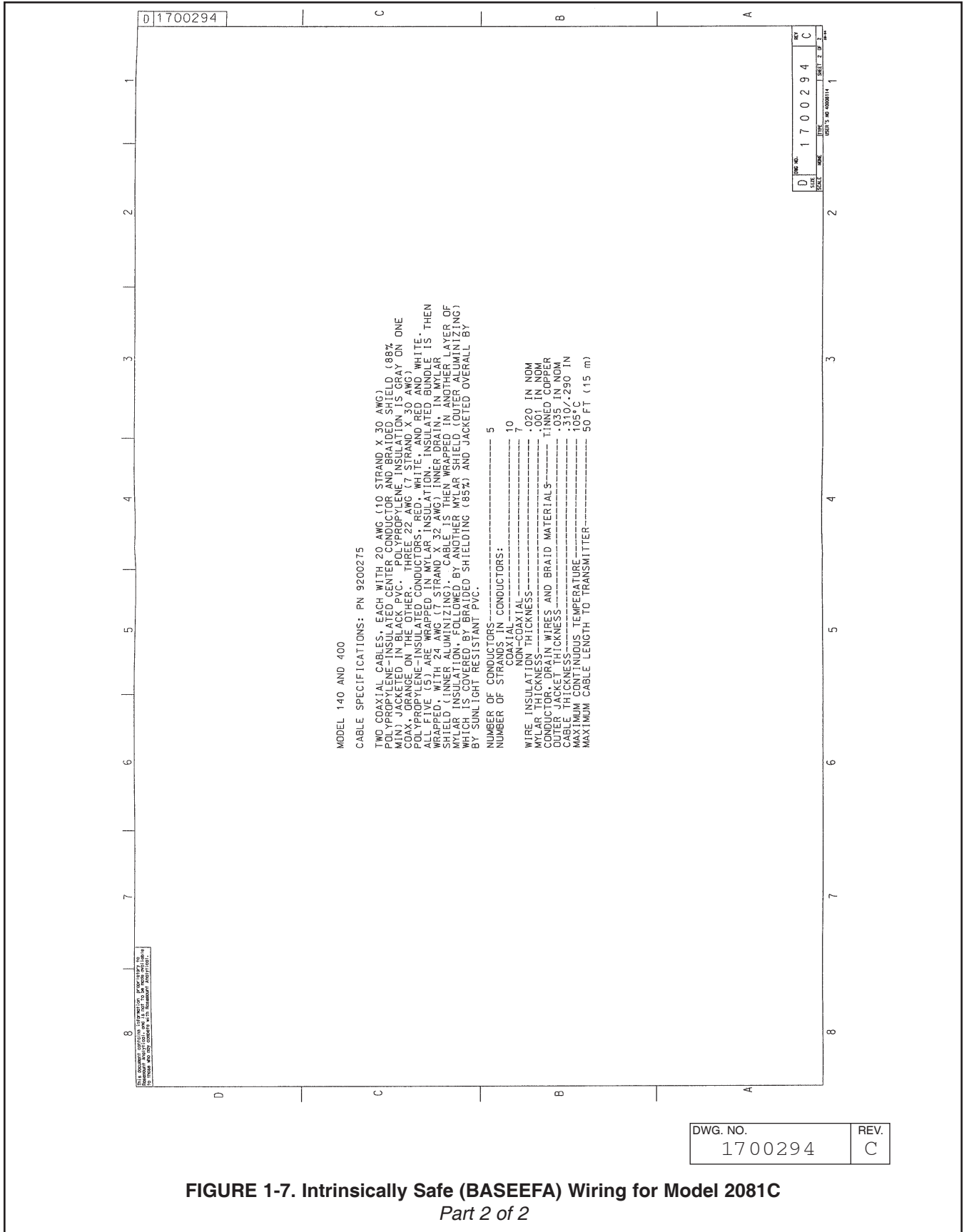

FIGURE 1-5. Sensor to Transmitter Switch Settings



DWG. NO.	REV.
1400160	A

FIGURE 1-6. Explosion Proof System Installation Schematic (FM)



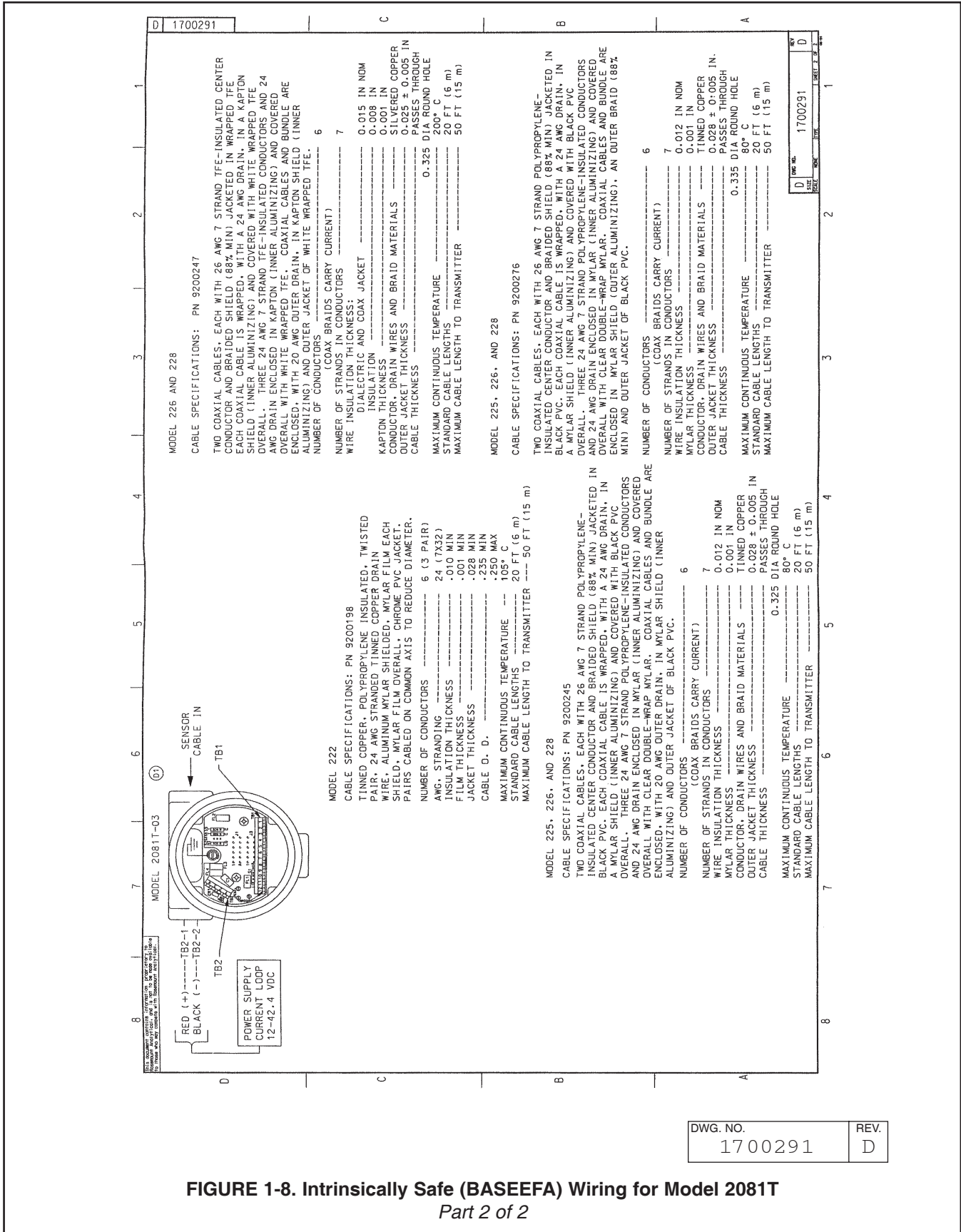
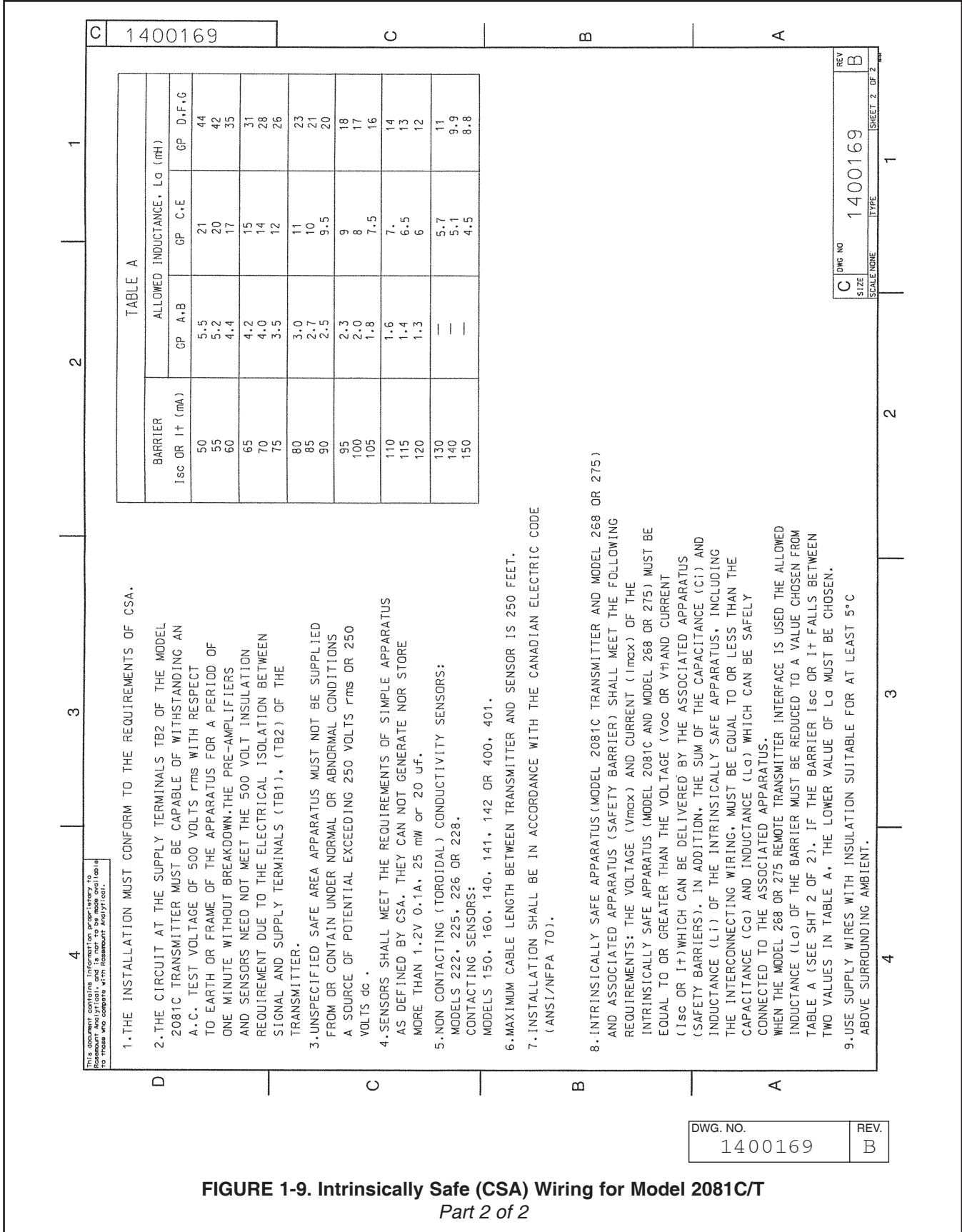

FIGURE 1-8. Intrinsically Safe (BASEEFA) Wiring for Model 2081T
Part 2 of 2



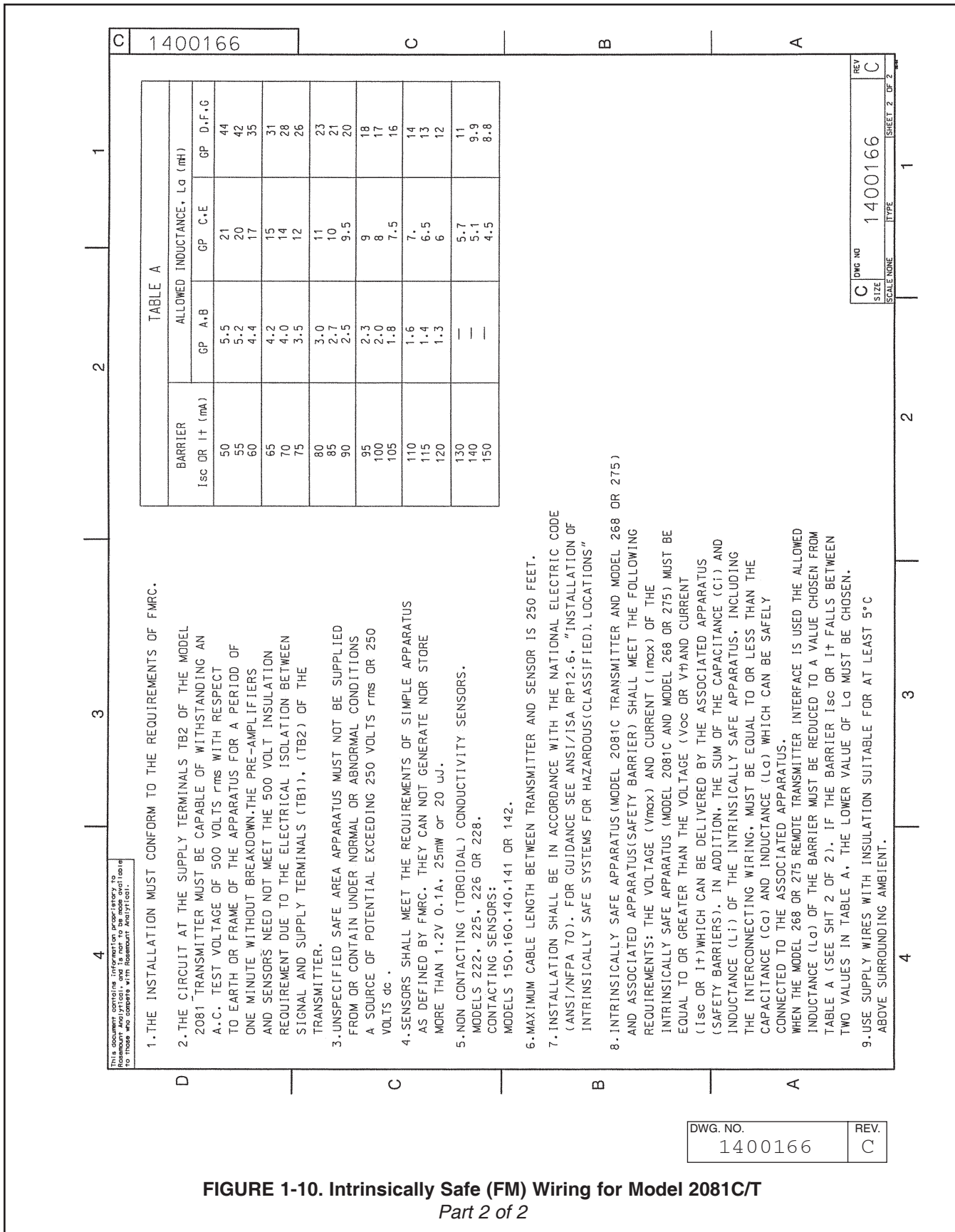

FIGURE 1-10. Intrinsically Safe (FM) Wiring for Model 2081C/T
Part 2 of 2

SECTION 2.0 DESCRIPTION OF CONTROLS

2.1 GENERAL. Nearly all functions of the transmitter are accessed through the dual push buttons. The transmitter uses no potentiometer.

2.2 MENU SELECTION. The dual push buttons are located on the side of the transmitter. Press **and hold** both buttons to display the transmitter menu items. See Figure 3-1. The display will show each item for about one second then scroll to the next item. It will continue to loop through the items until one is selected. To select an item, **release** both push buttons when the desired item is displayed.

NOTE

When no push button is pressed for a period of 60 seconds, the transmitter defaults to reading conductivity. If the push buttons are accidentally released and this would upset the process (e.g. EPC), escape by waiting 60 seconds for the transmitter to default to the conductivity reading.

2.2.1 Display Submenu. The display submenu (dI SP) is used to access secondary process values that cannot be changed.

To enter the submenu, scroll thru the main menu. When dI SP is on the LCD release both buttons. The display will read Cond . To see the conductivity value in this submenu, press both push buttons momentarily.

To scroll thru the submenus, press both buttons and **HOLD**. Submenu mnemonics will start scrolling. Release both buttons when mnemonic desired is displayed. Screen will display to value of submenu item selected. To view another value in the submenu press both buttons momentarily. Screen will revert to Cond , the entry screen for the submenu. – Repeat previous submenu actions.

To exit the submenu, press both push buttons and hold. Display will start scrolling thru the main menu items **or** take no action for 60 seconds and the display will default to the conductivity reading.

2.2.2 Display Flags and Hold Mode. The transmitter displays a flag on the LCD corresponding to the appropriate units.

When the transmitter is in hold output mode a flashing flag will appear on the middle right hand side of the display and HoLd will flash periodically. The output will remain at the last process value. To return the transmitter to normal operation, scroll to hoLd again and release both buttons.

2.3 VALUE ADJUSTMENT. Selection of a menu item that has a user-adjustable value will cause a numeric display with the right-most digit flashing.

- Depressing and holding push button #1 will cause the number flashing to increment upwards, looping back to zero.
- Depressing push button #2 will shift the flashing cursor to the next decade.
- Decimal position is shifted by pressing button #2 when the left most digit is flashing under the Std menu. Decimal will start flashing. Change location by pressing button #1.
- Select millisiemens/microsiemens flag by going through decimal position sequence and then pressing button #2. Flag will start flashing. Press button #1 to position the flag on the proper choice. Press button #2 once more and sensor will return to the starting point to change values. Press both buttons in momentarily to enter displayed value into memory.

NOTE

The autoranging feature on the 2081C/T will make decimal point setting and engr. unit settings unnecessary.

MAIN MENU	DISPLAY SUBMENU	
dI SP -----	Cond Conductivity value	<ul style="list-style-type: none"> • Press and hold both buttons auto scrolls through main menu and submenu. • Release buttons to select item. • Push button #1: Press and hold auto scrolls digits. • Push button #2: Press and hold auto shifts decades. • Enter a value: Depress both buttons briefly.
Std Standardize Conductivity	Fct Cell factor	
hoLd Initiate and remove hold output mode	curr Output in mA	
-0- Zero sensor loop	dIo Output in % of full scale	
LoC 4 mA range point	dC Temperature, °C	
HiC 20 mA range point	dF Temperature, °F	
CELL Cell constant	Cin Absolute conductivity	
tAdj Standardize temperature, °C		
Atc Automatic temperature compensation		
SLP Electrode slope (mV/pH)		
EP1 Calibration point one		
EP2 Calibration point two		

Figure 3-1. Menu Description

SECTION 3.0 RANGE CONFIGURATION

3.1 GENERAL. The conductivity range of the transmitter depends upon the sensor used. Table 3-1 can be used to determine ranges available with the sensor used. As shipped from the factory, 4 mA represents 0 siemens and 20 mA represents 2 siemens. The value displayed for these output currents are user selectable. To change the displayed readings in siemens for 4mA and 20mA proceed:

A. Output Zero (4 mA) Lo

1. Depress and hold both push buttons. The display will begin to auto scroll.
2. Release both keys when Lo is displayed. The present 4 mA conductivity value in memory will be displayed with the last digit flashing.
3. Depress and hold push button #1 (scroll) and #2 (shift) as needed to display the desired conductivity value.
4. Enter the value into memory by depressing both push buttons briefly. The display will return to displaying the present conductivity value.

B. Full Scale (20 mA) Hi

1. Depress and hold both push buttons. The display will begin to auto scroll.
2. Release both keys when Hi is displayed. The present 20 mA conductivity value in memory will be displayed with the last digit flashing.
3. Depress and hold push button #1 (scroll) and #2 (shift) as needed to display the desired conductivity value.
4. Enter the value into memory by depressing both push buttons briefly. The display will return to displaying the present conductivity value.

NOTE

For a reverse output, enter the higher value for Lo, and the lower value for Hi.

TABLE 3-1

SENSORS USED WITH MODEL 2081 CONDUCTIVITY										
Conductivity Sensor Model Number	142 400	142 150, 400	140 141	150	140, 141 150, 400	401	222	225	226	228
Cell Constant**	0.01	0.1	0.2	0.5	1.0	10.0	*	3.0	1.0	3.0
Min. Range	1	2	4	10	20	200	500	250	50	250
Max. Range	200	2,000	4,000	10,000	20,000	200,000	2,000,000	2,000,000	1,000,000	2,000,000
FULL SCALE MICROSIEMENS/cm										

* 1 in. diameter = 6.0, 2 in. diameter = 4.0 (Typical)

** Typical

TABLE 3-2. Measurement Ranges

Type Sensor	Maximum Range	Switch Setting
Toroidal	Below 400,000µS x Cell Constant Above 400,000µS x Cell Constant	Both "Lo" Both "Hi"
Contacting	Below 4,000µS x Cell Constant Above 4,000µS x Cell Constant	Both "Lo" Both "Hi"

SECTION 4.0 START-UP AND CALIBRATION

4.1 GENERAL. A sensor must be wired to the transmitter for calibration. See the appropriate sensor manual for additional instructions relating specifically to the sensor.

4.2 TEMPERATURE CALIBRATION. For the most accurate temperature compensation, the temperature reading may need adjusting. The following steps should be performed with the sensor in a grab sample or process of known temperature.

NOTE

Calibrate at or near the process temperature for greatest accuracy.

1. Scroll through the menu items. Press and hold both push buttons simultaneously.
2. When **TEMP**, is displayed, release both buttons. The display will show the present temperature value in degrees Celsius with the last digit flashing. The tenths digit will alternate between a value and °C.
3. Compare the displayed reading with a calibrated temperature reading device. If the reading requires adjustment, proceed to step 4. Otherwise, depress both push buttons briefly to accept the displayed value.
4. Depress and hold push buttons #1 (scroll) and #2 (shift) as needed to display the desired temperature value.
5. Enter the correct value into memory by depressing both push buttons briefly. The display will return to displaying the present conductivity value.

4.3 ENTERING THE CELL CONSTANT. The first time the analyzer is calibrated and any time there is a sensor change, the sensor cell constant must be entered into memory. Entering a cell constant into memory will reset the cell factor F_{CT} to 1.0 and will initiate the analyzer. The cell factor gives an indication of sensor fouling or coating. Refer to Section 6.0.

NOTE

The cell constant (K) will be found on the sensor label (i.e. K = 3.04, K = 1.00) located on the cable. For Models 140, 141, and 142. The cell constant is shown on the junction box label. (For the Model 222 the label is on spindle).

1. Scroll through the menu items. Press and hold both push buttons simultaneously.
2. When **CELL**, is displayed release both buttons. The display will show the cell constant in memory with the right most digit flashing.
3. Press and hold buttons #1 (scroll) and #2 (shift) as needed to display the correct cell constant.
4. Enter the correct value into memory by briefly pressing both push buttons simultaneously. The display will return to displaying the present conductivity value.

4.4 ZEROING THE SYSTEM. The transmitter must calibrate the zero point before the sensor is placed into the process solution.

CAUTION

DO NOT PLACE THE SENSOR IN THE PROCESS. The sensor must be placed into solution only after performing a system zero.

1. Assure that the sensor is properly wired and out of process (in air).
2. Scroll through the menu items. Press and hold both push buttons simultaneously.
3. When **0.00**, is displayed, release both buttons. The transmitter will calculate the loop zero point. This takes about 10 to 20 seconds. **0.00** will flash on the display while the transmitter is calibrating. The display will return to displaying conductivity when the zero calibration is complete.
4. Place the sensor in solution and proceed with the system calibration.

4.5 INITIAL LOOP CALIBRATION. Please read the entire calibration section before proceeding to determine the best calibration procedure. Also, please check the appropriate sensor manual's calibration section for any specific instructions.

4.5.1 Two Point Calibration - Process temperature slope not known. Recommended procedure for the initial calibration if the process temperature slope is not known. If any of the steps below are impossible or impractical to perform, refer to alternate Section 4.5.2.

1. Obtain a grab sample of the process to be measured.
2. Determine the sample's conductivity using a calibrated instrument or portable analyzer. The instrument must be able to reference the conductivity to 25°C, or the solution must be measured at 25°C. Record the reading.

NOTE

The transmitter must be in hold or off line.

3. Immerse the measuring portion of the sensor in process solution. (Model 222 users should refer to the sensor's manual for special instructions). The sensor body must be held away from the bottom and sides of the sample's container at a distance at least the diameter of the sensor. Shake the sensor to ensure that no air bubbles are present.
4. Adjust the sample's temperature to either the normal high or normal low process temperature. (To raise the sample's temperature, a hot plate with stirrer may be used. To lower the sample temperature, place the grab sample's container in an ice bath or let it slowly cool down).
5. Allow the sensor to acclimate to the sample temperature. (The temperature reading should be stable).
6. Scroll through the menu items. Press and hold both push buttons simultaneously.
7. When EPC is displayed, release both buttons. The display will show the conductivity value in memory with the right most digit flashing.
8. Depress and hold buttons #1 (scroll) and #2 (shift) as needed to display the grab sample's conductivity value at 25°C as noted in step 2.
9. Enter the correct value into memory by briefly depressing both push buttons simultaneously. The display will return to displaying the present conductivity value.
10. Adjust the sample's temperature to the process's other normal temperature extreme.
11. Allow the sensor to acclimate to the sample temperature. (The temperature reading should be stable).

12. Scroll through the menu items. Press and hold both push buttons simultaneously.
13. When EPC is displayed, release both buttons. The display will show the conductivity value in memory with the right most digit flashing.
14. Depress and hold buttons #1 (scroll) and #2 (shift) as needed to display the grab sample's conductivity value at 25°C as noted in step 2.
15. Enter the correct value into memory by briefly depressing both push buttons simultaneously. The display will return to displaying the present conductivity value.

The analyzer then calculates the true cell constant and the process temperature slope, then returns to reading conductivity.

The temperature slope of the process can now be read by selecting SLP from the menu.

The sensor may now be installed in the process.

NOTE

If the 2081 was placed in hold, be sure to remove it from hold after the sensor is on line.

4.5.2. Single Point Calibration - Process Temperature Slope Known. This is the recommended procedure for the initial calibration if the temperature slope of the process is known. If you do not know the exact temperature slope value, but wish to approximate it, refer to the following guide.

Acids:	1.0 to 1.6%/°C
Bases:	1.8 to 2.2%/°C
Salts:	2.2 to 3.0%/°C
Water:	2.0%/°C

1. Scroll through the menu items. Press and hold both push buttons simultaneously.
2. Release both buttons simultaneously when SLP is displayed. The slope value in memory will display with the right most digit flashing.
3. Depress and hold buttons #1 (scroll) and #2 (shift) as needed to display the desired temperature slope value.
4. Enter the correct value into memory by briefly depressing both push buttons simultaneously. The display will return to displaying the present conductivity value.

- Obtain a grab sample of the process to be measured.

NOTE

Be sure the transmitter is in Hold or Off-Line.

- Determine the sample's conductivity using a calibrated instrument or a portable analyzer. The instrument must be able to reference the conductivity to 25°C, or the solution must be at 25°C. Write down the reading. Ensure that the analyzer is in hold.
- With the sensor in sample, depress and hold both push buttons simultaneously to enter the transmitter menu. The transmitter will auto scroll through the menu items. Release both push buttons when S_{td} is displayed. The conductivity value will display with the right most digit flashing.
- Depress and hold buttons #1 (scroll) and #2 (shift) as needed to display the conductivity value noted in step 5. Depress both push buttons simultaneously to accept this value. The transmitter will then calculate the proper cell constant.

NOTE

Return transmitter to normal operation from Hold.

4.6 ROUTINE STANDARDIZATION. The sensor should be standardized in-line routinely if it is suspected that the process might degrade or coat the sensor. After the initial calibration, each time a standardization is performed the cell factor F_{ct} is changed. Refer to Section 4.3 for a description of the cell factor.

To perform a standardization do the following:

- Take a grab sample which is as close to the sensor as possible. Record transmitter reading.
- Determine the sample's conductivity using a calibrated instrument or a portable analyzer. The instrument must be able to reference the conductivity to 25°C, or the solution must be at 25°C. Record the reading.
- Note any change in the 2081's present reading from first reading recorded in Step 1. Add this change (either + or -) to the calibrated instruments value. Record this figure.
- Scroll through the menu items. Press and hold both push buttons simultaneously.
- Release both push buttons when S_{td} is displayed. The conductivity value will display with the right most digit flashing.

- Depress and hold buttons #1 (scroll) and #2 (shift) as needed to display the conductivity value noted in step 3.

Depress both push buttons simultaneously to accept this value.

The transmitter will then calculate the proper cell factor.

- Depress both push buttons simultaneously and release when d_{SP} is displayed.

Depress both push buttons again and release when F_{ct} is displayed.

Note this value to determine a sensor maintenance schedule.

4.7 HOLD MODE FOR MAINTENANCE. Before performing maintenance of the sensor, or buffer checks, the transmitter should be placed in the $Hold$ mode. This mode of operation maintains the output current at the last process value. To initiate $Hold$ mode:

- Depress and hold both push buttons simultaneously until $Hold$ is displayed on the screen.
- Release both buttons.
 - The $Hold$ flag will flash, and
 - The display will show $Hold$ every two seconds to confirm the hold status.

To place the transmitter back into normal operation, (remove from $Hold$ mode):

- Depress and hold both push buttons simultaneously until $Hold$ is displayed on the screen.
- Release both buttons.
 - The $HOLD$, flag will stop flashing.
 - The display will stop showing $Hold$ every two seconds.
 - The transmitter output current will return to normal operation.

4.8 SENSOR MAINTENANCE. Always calibrate after cleaning or repair of the conductivity sensor.

Always place transmitter into the $Hold$ mode of operation while performing any maintenance to the sensor to avoid loss of process control.

Always return transmitter to normal operation after installing the sensor back into the process.

SECTION 5.0 KEYBOARD SECURITY

5.1 PUSH BUTTON SECURITY. This feature disables the dual push buttons on the transmitter to prevent accidental or unauthorized changes to the calibration and configuration. HART communication is not affected by this change. Perform the following steps to disable the push buttons. See Figure 5-1 for jumper locations on CPU board.

CAUTION

The circuit board is electrostatically sensitive. Be sure to observe handling precautions for static-sensitive components.

1. Remove the display side cover.
2. For easy access, the electronics assembly may be removed by pulling the assembly straight out.
3. Remove jumper JP4 from the CPU board. To prevent misplacing the jumper, slide it back onto one post only.
4. Replace the display side cover.

CAUTION

A minimum of seven cover threads must be engaged in order for the transmitter to meet explosion-proof requirements.

5.2 FAULT MODE SELECTION This feature allows the user to select the desired mA output during a system disabling fault condition.

CAUTION

The circuit board is electrostatically sensitive. Be sure to observe handling precautions for static-sensitive components.

1. Remove the display side cover.
2. For easy access, the electronics assembly may be removed by pulling the assembly straight out.
3. JP3's Fault Mode Selection
 Jumper on both posts: below 4.0 mA
 Jumper on one post: above 20.0 mA
4. Replace the display side cover

CAUTION

A minimum of seven cover threads must be engaged in order for the transmitter to meet explosion-proof requirements.

Replace the jumper to enable push button operation.

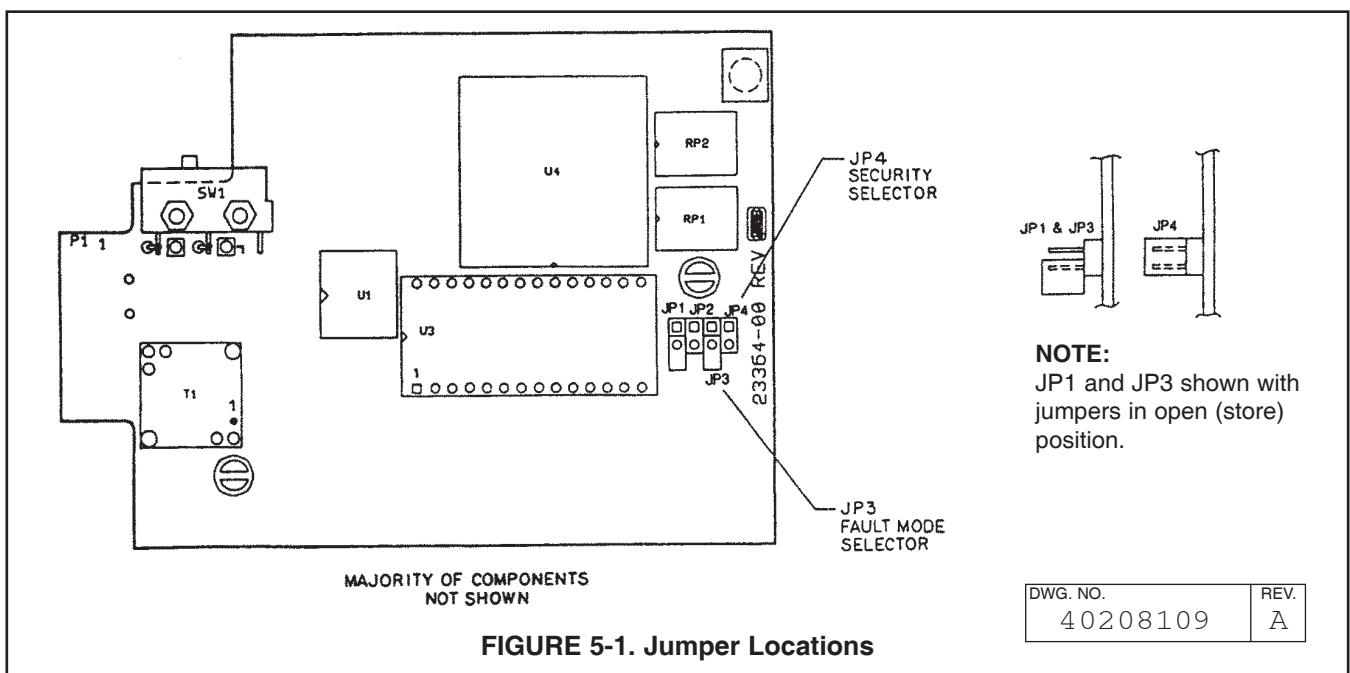

SECTION 6.0 DIAGNOSTICS AND TROUBLESHOOTING

6.1 GENERAL: The Model 2081C/T Transmitter automatically searches for fault conditions that would cause an error in the measurement. If such a condition exists, the 2081C/T transmitter will flash a diagnostic message. If more than one fault exists, the display will sequence through the diagnostic messages. This will continue until the cause of the fault has been corrected.

Troubleshooting is easy as 1,2,3. . .

- Step 1** Look for a diagnostic fault message on the display to help pinpoint the problem. Refer to Table 6-1 for an explanation of the message and a list of the possible problems that might have triggered it.
- Step 2** Refer to the Quick Troubleshooting Guide, Table 6-4 for common loop problems and the recommended actions to resolve them.
- Step 3** Follow the step-by-step troubleshooting approach offered in Section 6.2 to diagnose less common or more complex problems.

In addition, a theory of operation explanation is offered in section 7.0 for those that may want a more detailed understanding of the instrument.

NOTE

During fault conditions the output of the transmitter is determined by the placement of Jumper JP3 on the CPU board.

1. JP3 in place (shorted across both pins) Output driven below 4 mA.
2. JP3 on one pin only - Output driven above 20 mA.

6.1.1 Diagnostic Messages. Table 6-1 lists the fault displays, describes the meaning of each and lists some appropriate corrective actions for each.

TABLE 6-1. Diagnostic Messages

Display	Description	Corrective Action
Adc - FAi L	Transmitter electronics failure	Turn power off, wait one minute, and power on. Replace stack.
SnSr - rRGE	Conductivity value outside 4-20 mA range points.	Check Sensor cell constant and measurement range. Return conductivity to within range, or replace sensor.
SnSr - FAi L	Sensor failure or A-D failure	Replace sensor. Replace stack.
tEnP - Lo	Temperature too low or RTD shorted	Check wiring, calibrate temperature, bring sensor within temperature specifications, replace stack, replace sensor. Note: if in manual temp mode, RTD or appropriate resistor must be in place. See Table 6-2.
SLP - FAi L	Invalid temp. slope calculated. Did not accept entry. performed at 2 different process temperatures.)	Turn power off and on. Repeat temp. slope calibration procedure. (Must be
-0- FAi L	Too much resistance is sensed to zero (over 1Meg). Did not accept entry.	Check wiring. Verify sensor is in air during sensor 0: Not partially submerged.
Std - FAi L	Entered conductivity value is unacceptable (+/- 15°C).	Conductivity calibration failed: verify conductivity standard or grab sample. Temp. calibration failed: verify temp at the sensor: allow 20 minutes for stabilization.
Loop - rRGE	Conductivity value is outside of the present Lo and Hi range setpoints.	Bring conductivity back into the programmed range. Re-adjust Lo and Hi range setpoints.
Flashes bAd	You have attempted to enter a value that exceeds the allowable software.	Verify the attempted procedure's instructions. Check standard or instrumentation used.
FAi L	The transmitter recognizes that its electronics have malfunctioned	Check wiring Turn power off and on. Replace electronic stack.

NOTE: Some of the fault codes can be cleared by cycling the power off and on.

6.1.2 Temperature Compensation. Table 6-2 (below) is a reference of RTD resistance values at various temperatures. These are used for test and evaluation of the sensor.

NOTE

Ohmic values are read across the RTD element and are based on the manufacturer's stated values (+/- 1%). Allow enough time for the RTD element to stabilize to the surrounding temperature.

Table 6-2. Resistance Values (Temperature)

Temperature	Resistance
0°C	100.00 Ohms
10°C	103.90 Ohms
20°C	107.90 Ohms
30°C	111.67 Ohms
40°C	115.54 Ohms
50°C	119.40 Ohms
60°C	123.24 Ohms
70°C	127.07 Ohms
80°C	130.89 Ohms
90°C	134.70 Ohms
100°C	138.50 Ohms

6.2 CONTACT CONDUCTIVITY MODE BENCH CHECK: Sensor simulation may be used to check the operation of the model 2081C/T. See Figure 6-1 for wiring diagram to perform analyzer check.

CAUTION

Do not use over 55 volts to check the loop. Damage to the transmitter may result.

1. Set up transmitter as shown in Figure 6-1.
2. Simulate a conductivity value by choosing a typical resistance value from Table 6-3 and entering this resistance value into the decade box.

TABLE 6-3. Resistance Values (Conductivity)

Simulate Full Scale Conductivity Of:	Resistance Value To Use:
20 microsiemens	50,000 ohms
200 microsiemens	5,000 ohms
2000 microsiemens	500 ohms
20,000 microsiemens	50 ohms

NOTE

Chart assumes a cell constant of 1.0. Therefore, Resistance = 1/Conductivity.

3. Apply power to the Loop.
4. Set the CELL constant to 1.00.
5. Set the REC to USER. Enter the user value of 25° C. (This eliminates temperature condition.)
6. Remove one test lead from the resistance decade box to simulate 0.00 Microsiemens.
7. Select the zero function -0- from the Level 1 menu.
8. The display will flash -0- while the unit zeros.
9. Reconnect the test lead to the decade box to simulate full-scale conductivity.
10. If calibrated, the display should read close to the full-scale conductivity value.
11. Scroll to SET and enter the desired full-scale conductivity value
12. Check half-scale reading by doubling the resistance value entered into the decade box.
13. The transmitter conductivity circuitry is operating correctly if it will zero, read the full-scale and half-scale conductivity values.

6.3 TOROIDAL CONDUCTIVITY MODE BENCH

CHECK: Sensor simulation may be used to check the operation of the Model 2081C/T. See Figure 6-2 for wiring diagram to perform analyzer check.

CAUTION
Do not use over 55 volts to check the loop.
Damage to the transmitter may result.

1. Set up transmitter as shown in Figure 6-2.
2. Simulate a full scale conductivity value by choosing a typical resistance value from Table 6-3 and entering this resistance value into the decade box.

TABLE 6-3. Resistance Values (Conductivity)

Simulate Full Scale Conductivity Of:		Resistance Value To Use:	
20	microsiemens	50,000	ohms
200	microsiemens	5,000	ohms
2000	microsiemens	500	ohms
20,000	microsiemens	50	ohms

NOTE

Chart assumes a cell constant of 1.0.
Therefore, Resistance = 1/Conductivity.

3. Apply power to the Loop.
4. Set the CELL constant to 1.00.
5. Set the R_{TC} to USER. Enter the user value of 25° C. (This eliminates temperature correction.)

6. Remove one test lead from the resistance decade box to simulate 0.00 Microsiemens.
7. Select the zero function -0- from the Level 1 menu.
8. The display will Flash -0- while the unit zeros.
9. Reconnect the test lead to the decade box to simulate full-scale conductivity.
10. If calibrated, the display should read close to the full-scale conductivity value.
11. Scroll to SET and enter the desired full-scale conductivity value.
12. Check half-scale reading by doubling the resistance value entered into the decade box.
13. The transmitter conductivity circuitry and the sensor are operating correctly if it will zero, read the full-scale and half-scale conductivity value. If not, refer to the appropriate sensor instruction manual to perform tests on the toroidal sensor. If the sensor tests O.K, then replace the transmitters electronic stack.

6.4 SYSTEMATIC TROUBLESHOOTING.

Not all problems that you encounter will be typical. If you are unable to resolve your problem using the Quick Troubleshooting Guide, Table 6-4, then try the step-by-step approach offered in Figure 6-3.

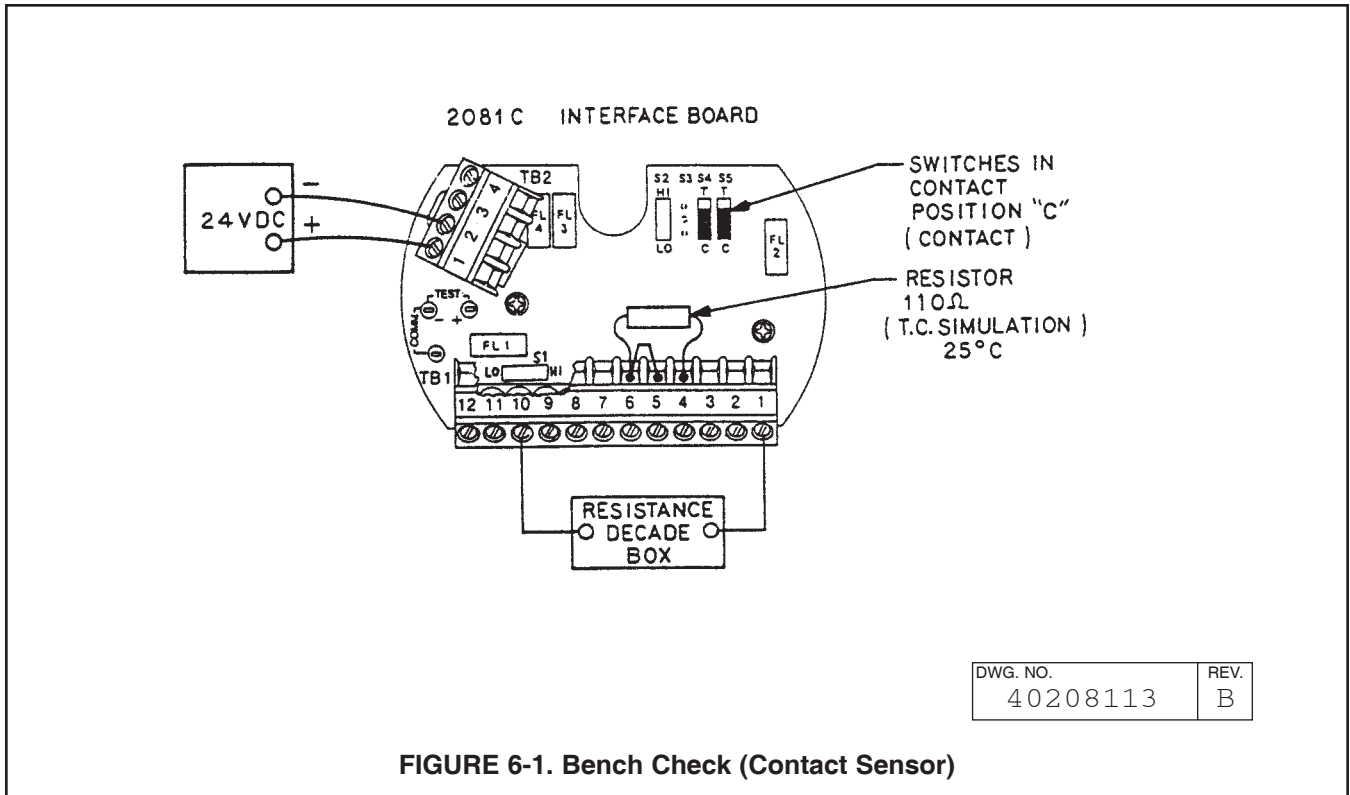

FIGURE 6-1. Bench Check (Contact Sensor)

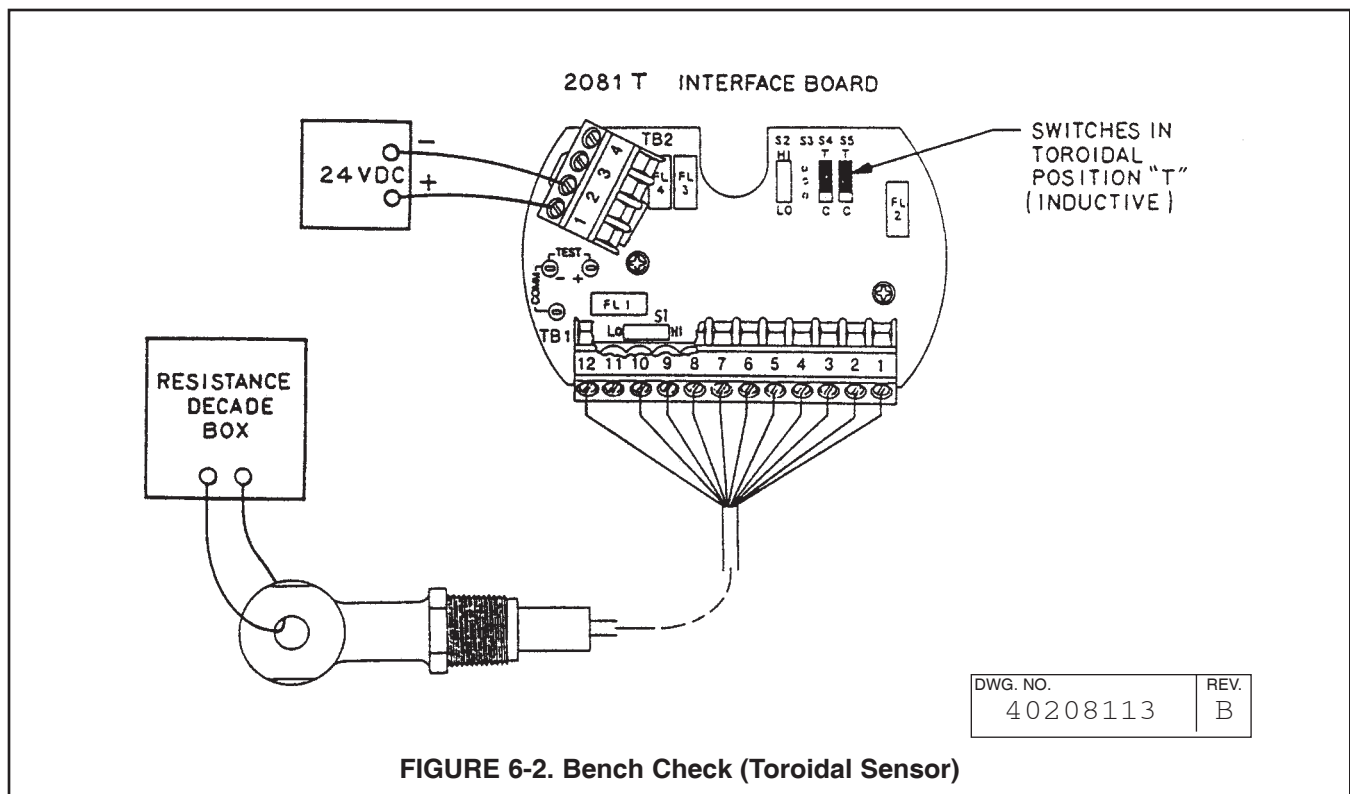
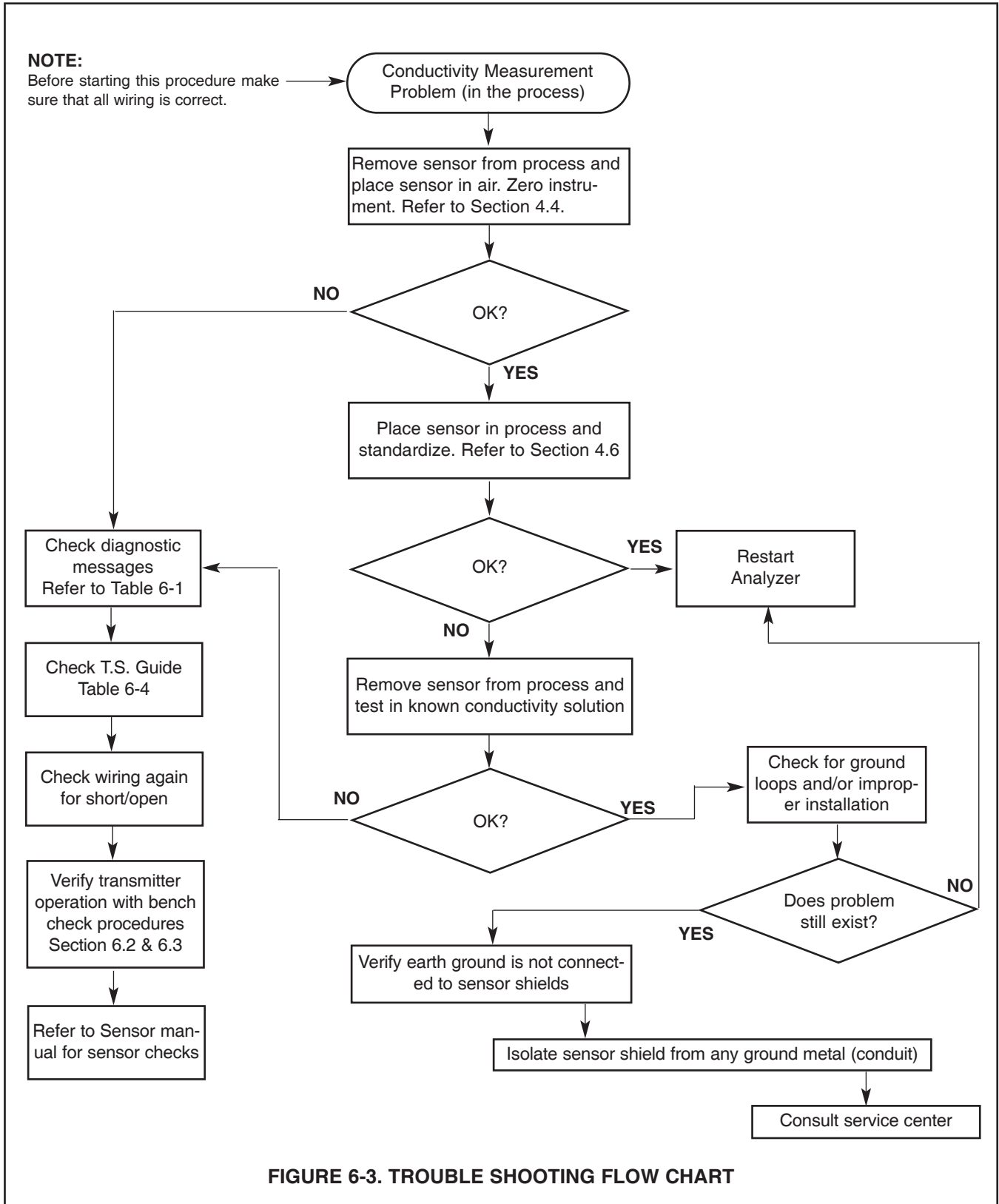

FIGURE 6-2. Bench Check (Toroidal Sensor)

TABLE 6-4. Quick Troubleshooting Guide

SYMPTOM	PROBLEM	ACTION
F _{cell} below 0.5 or above 2.0. Actual range determined by user.	1. Old or coated sensor.	1. Clean or replace glass electrode. 2. A preceding standardization was incorrect.
Value locks up (no change of reading in different standards).	1. Incorrect wiring. 2. Open sensor.	1. Verify wiring. 2. Perform sensor checks. 3. Replace sensor.
2081C/T value not the same as grab sample of process.	1. Grab sample incorrect. 2. Unclear what is correct. 3. 2081C/T out of calibration.	1. Re-evaluate sample technique and equipment. 2. Test with standard solution. 3. Recalibrate per start-up and calibration sections.
Fault Code ϵE_{nP-L_o} , or ϵE_{nP-H_i}	1. Incorrect wiring. 2. Open or shorted RTD. 3. Manual temperature mode.	1. Check wiring between the sensor and the transmitter. 2. Replace RTD or sensor. 3. Appropriate resistor must be in place - TB1-6 to 8. See Table 6-2.
Zero Conductivity reading.	1. Sensor wired incorrectly. 2. Solids coating sensor. 3. Open wire in sensor.	1. Repair wire connection. 2. Clean sensor. 3. Replace sensor.
Fault code RANGE-LOOP.	1. Process value is outside 4-20 mA range points.	1. Return process to normal. Check grab sample.
Fault Code FRI L.	1. Range selection switches S1 and S2 are set incorrectly. 2. Defective PCB stack.	1. Calculate the maximum low range value and set the switches accordingly. See Section 1.3.3. 2. Reconnect power or if necessary, replace PCB stack.
No output current.	1. Defective PCB stack. 2. Incorrect wiring.	1. Replace PCB stack. 2. Check for short.
Low output current.	1. Circuit loading with excessive resistance on output.	1. consult output loading limits 2081C/T specifications (1840 ohms max load).
Drifting or Unstable readings.	1. Air bubbles in process affecting reading. 2. Electrical or grounding interference.	1. Mount sensor to decrease exposure to air bubbles. 2. Verify sensor works in a standard solution outside of the process. 3. Verify near by vendor pumps are properly grounded. 4. Verify that sensor shield never touches an Earth ground. 5. Run sensor cable though grounded metal conduit to reduce RFI effects.
Fault code "LOOP" flashing intermittently with Conductivity and output value.	1. Model 268 or other host has set the output to a specific value.	1. Model 268 or other host can return transmitter to normal operation.
Can't calibrate new sensor.	1. Wrong sensor for measurement range. 2. Sensor incompatible with analyzer.	1. Verify that cell content is correct for the measurement range. 2. Verify sensor has a PT-100 temperature compensator.
Transmitter won't communicate.	1. Incorrect wiring. 2. Insufficient load resistance. 3. Electronics failure.	1. Check wiring and model 268 connections. 2. Verify minimum of 500 Ohm loop resistance. 3. Replace electronic stack.



SECTION 7.0 THEORY OF OPERATION

7.1 GENERAL: Conductivity is the conductance per unit of length. The 2081C/T measures and calculates conductivity using the relation $I=GV$. Where:

G = conductance,

V = the reference voltage, and,

I = the resultant current directly proportional to conductance.

7.2. OVERVIEW: Refer to Figure 7-1 2081C/T Block Diagram.

Power Supply: Power for the 2081C/T is derived from the +12 to 55 volt DC loop power. This power is dropped to a regulated +9 volts DC and maintained by comparison with the output of a 2.5 volt op-amp comparator. The 9 volts DC is switched by a 28.8 KHz square wave signal from the Oscillator across the center tapped primary of the drive transformer. This provides the raw 4.5 VAC for the 4.5 Volt DC power supply.

The 28.8 KHz square wave signal from the oscillator also develops an AC at the secondary that is used to drive a toroidal (or contacting) conductivity sensor.

When a contacting conductivity sensor is used this isolates the 2081C/T electronics from the process, and the AC signal also prevents polarizing of the fluid surrounding a contacting conductivity sensor.

Oscillator: The 1.8432 MHz oscillator output is divided down to provide:

1. a 921.6 KHz CPU clock signal.
2. a 460.8 KHz MODAC clock signal.
3. a 57.6 KHz demodulator sample signal.
4. the 28.8 KHz transformer drive signal.

Input Signals: RTD and sensed cable line voltages appear at an input to the Mux. These voltages are converted to digital values by the A/D circuits, and stored by the CPU. The CPU subtracts the unwanted cable voltage from the RTD voltage and uses these readings with a reference voltage to calculate the sensor temperature. This value is used to compensate the absolute conductivity using the temperature slope of the liquid, and can be sent to the LCD to be displayed.

1. Sensors: This transmitter can be used with either type of sensor. Contacting or Toroidal inductive).

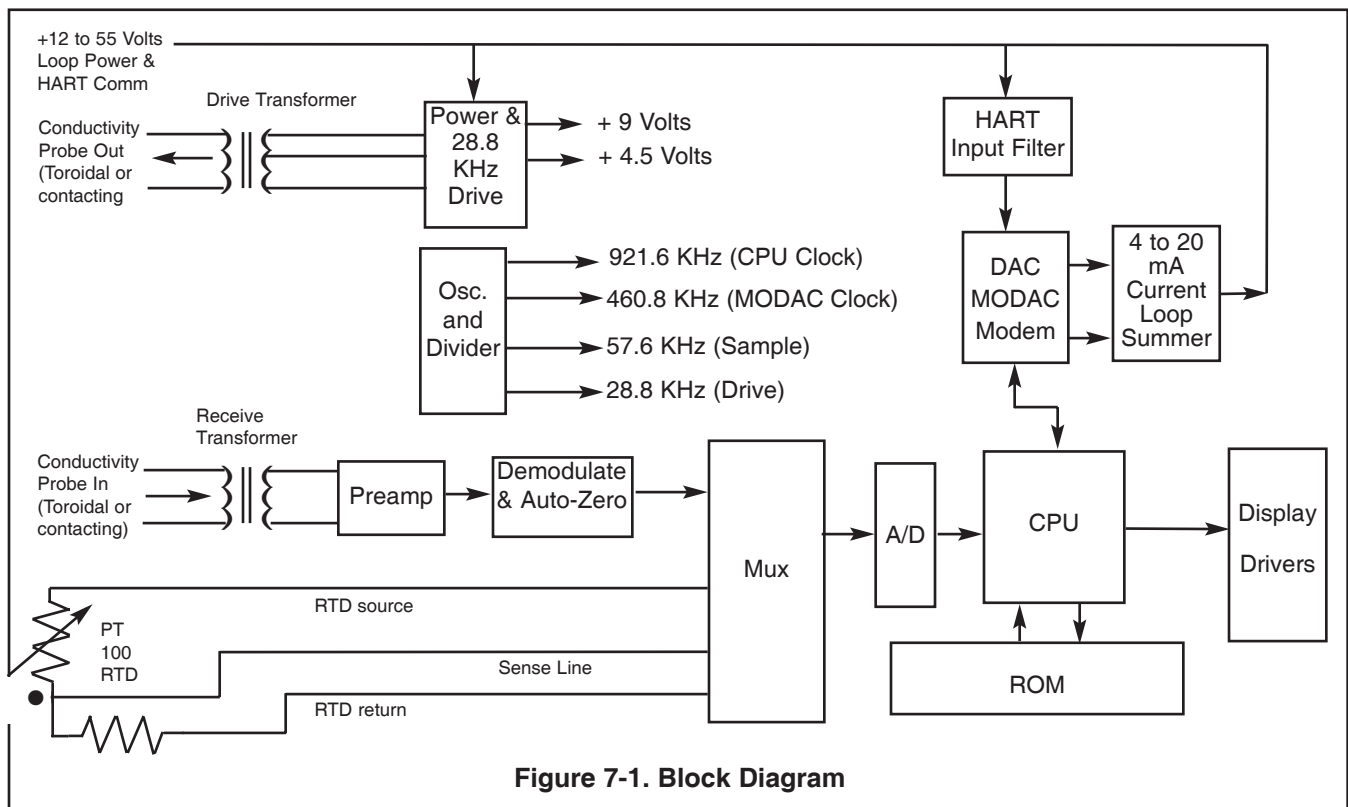

Figure 7-1. Block Diagram

Sensors: This transmitter can be used with either type of sensor. Contacting or toroidal (inductive). Currents developed by the conductivity probe through the Receive Transformer are converted to a voltage and amplified by the preamplifier block. This voltage is demodulated (in the demodulate and auto-zero block) in phase with the transmitter toroid resulting in a DC voltage representing the absolute conductivity.

- a. **Contact Conductivity Probe.** In the contacting sensor, the area and distance between the two electrodes determine a cell constant, the volume of fluid between the electrodes acts as a resistor whose value depends on the conductance of the fluid.
- b. **Toroidal Conductivity Sensor.** Consists of two independent transformers that have a common turn, the path of the liquid. The transmitter toroid, or driver, induces a voltage in the path of the liquid which is the voltage across the toroid winding divided by the number of turns in the winding. The voltage times the conductance results in a current that is proportional to the conductance. This current is sensed by the receiver toroid. The current out of this toroid is the current in the liquid loop divided by the number of turns in its winding. The result is $I = G \cdot V / (N1 \cdot N2)$, where:

N1 is the number of turns of the transmitter toroid.

N2 is the number of turns of the receiver toroid.

V is the voltage across the receive transformer.

G is the conductance of the liquid loop.

I is the resultant current developed in the receiver transformer by the receive toroid.

HART communication signals. Super-imposed on the 4 to 20 mA current loop, are passed through the HART Input filter (to reduce noise). This FSK signal is then demodulated by the MODAC ASIC (Application Specific Integrated Circuit) and sent on to the CPU via the MODAC. A FSK signal is an AC signal, whose frequency is shifted higher or lower depending on the condition of the digital signal (High or Low), This Frequency Shift Keying is mixed with the DC value of the 4 to 20 mA signal, using Bell 202 protocol. This communication conforms to the Rosemount HART specification and may be used to configure and interrogate the transmitter.

CPU: A 68HC11 micro controller computer chip contains the central processing unit (CPU). This chip also contains volatile Random Access Memory (RAM) and nonvolatile Electrically Erasable Programmable Read Only Memory (EEPROM). CPU instructions, however, are stored in an external ROM. The CPU communicates with this external ROM, Mux, Analog to Digital (A/D) converter, the two push buttons on the side of the 2081C/T, and the Model 275 Smart Interface through the MODAC. It also controls the display drivers,

When requested by the CPU the input signals from either the Contacting or Toroidal sensor are zeroed and scaled between user supplied setpoints to determine what the proportional current value of the 4 to 20 mA loop should be. This value is sent to control the Digital to Analog Converter (DAC) in the MODAC ASIC. The MODAC also produces a weighted Pulse Width Modulated output representing digital information generated by the CPU to communicate with other digital devices on the current loop. Both of these signals are sent to the current loop summer. The summer then mixes this PWM signal with the current loop value to produce the correct 4 to 20 mA output value for the transmitter.

SECTION 8.0 DESCRIPTION AND SPECIFICATIONS

- UTILIZES EITHER CONTACTING OR INDUCTIVE CONDUCTIVITY SENSORS to meet a wide range of application requirements.
- FIELD MOUNTED TRANSMITTER ideal for central data processing and control.
- MEMBER OF THE ROSEMOUNT SMART FAMILY®.
- LOCAL, PUSH-BUTTON INTERFACE for convenient calibration and range adjustment.
- WEATHERPROOF, CORROSION-RESISTANT ENCLOSURE.
- CONTINUOUS DIAGNOSTICS drive the output to a jumper-selectable high or low value in the event of a failure.
- HOLD OUTPUT MODE for manual control during sensor maintenance.

8.1 FEATURES

The Model 2081 C Smart Transmitters, with the appropriate sensor, are designed to continuously measure contacting, toroidal, or conductivity in industrial and municipal processes. These two-wire transmitters are members of the Rosemount SMART FAMILY of instruments, which are designed to communicate with the hand-held Model 275 SMART FAMILY Interface and any other hosts that support the HART® communications protocol. See Figure 8-1. The Model 2081 design permits remote configuration, interrogation, testing, and diagnostics.

The Model 2081 C features an easy-to-use, dual push-button interface on the transmitter housing for local calibration and range adjustment. The LCD display indicates the conductivity value as well as temperature, current output value, range values, temperature slope, and fault messages. Unauthorized adjustments may be prevented by a jumper-selectable setting on a circuit board. All functions are microprocessor based.

The isolated 4-20 mA output is continuously expandable over the measurement range, and may be displayed in either milliamps or percent of full scale. A hold output function is available for manual control during routine sensor maintenance. While in hold mode the current output signal (refer to Table 1) will remain constant at the last current value.

In the event of a failure, the transmitter diagnostic routine will drive the output below 4 mA or above 20 mA (user selectable) in addition to displaying a fault code on the transmitter. This routine alerts the user to errors due to temperature slope, faulty temperature compensation element, open wiring and transmitter electronics failure. The transmitter will also go into a fault mode if the conductivity value is outside the output range settings.

With a two-point calibration, the transmitter automatically calculates the temperature slope and the cell constant. On-line standardization is easily accomplished by simply entering the conductivity value of a grab sample into the transmitter. The transmitter uses a Pt100 RTD signal from the sensor to reference the conductivity reading to 25°C.

The Model 2081 C transmitter is designed to be weatherproof and corrosion resistant to meet NEMA 4X (IP65) standards. An optional pipe or wall mounting bracket is available.

The transmitter communicates via the HART® protocol, which uses an industry standard BELL 202 frequency shift keying (FSK) technique. Communication is accomplished by superimposing a digital signal on top of the 4-20 mA output signal. The Rosemount implementation of this technique allows simultaneous communication and output without compromising loop integrity.

The Model 2081 requires an external power supply such as the Model 515 Isolated Power Supply or DC loop power from a distributed control system. The Model 515 Power Supply provides power for up to 10 transmitters. Two transmitters may be wired directly to the power supply. For more than two transmitters, junction boxes are available, each accommodating wiring for a maximum of ten transmitters.

Remote alarms with independently adjustable setpoints and hysteresis are available in the Model 230A Alarm Module. Contacts of the Model 230A may be specified for high/low, high/high, or low/low operation.

8.2 FUNCTIONAL SPECIFICATIONS

Output: Two-wire 4-20 mA with superimposed HART digital signal.

Power Supply and Load Requirements: See Figure 8-1 below. A minimum loop resistance (load) of 250 ohms and minimum power supply voltage of 18 volts DC is required for digital communication.

Local Indication: Four digit LCD

Ambient Temperature: -30 to 70°C (-22 to 158°F)

Failure Mode Alarm: The analog signal will be driven either below 4 mA or above 20 mA (user-selectable)

Transmitter Security: Security activation (by internal jumper) prevents changes to the transmitter configuration from the local interface.

Relative Humidity : 0-95%

Automatic Temperature Compensation: Pt100 RTD 0 to 200°C (32 to 392°F)

Enclosure: Weatherproof and corrosion-resistant, explosion proof

EMI/RFI: EN-61326

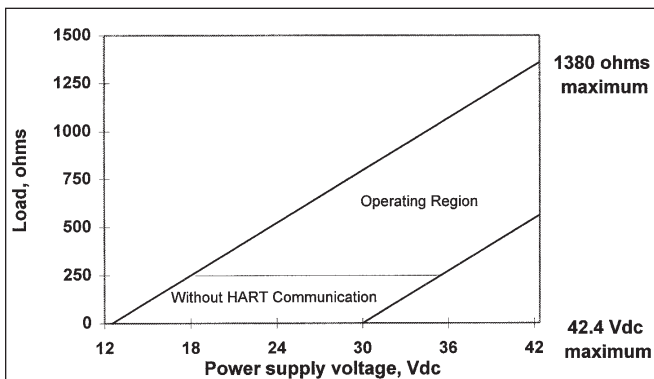

FIGURE 8-1. Load/Power Supply Requirements

8.3 PERFORMANCE SPECIFICATIONS

Range*: See Table 8-2

Output Scale: Zero Suppression: Up to 90% of full scale

Span: From 10 to 100% of full scale

Accuracy: ±0.5% full scale @ 25°C

Resolution: 0.1% full scale, 0.1°C

Repeatability: ±0.25% full scale

Stability: 1%/ year at 25°C

Temperature Effect: 0.02% F.S./°C

Vibration Effect: ±1.0% of F.S. per SAMA PMC 31.1

* Not applicable for ultra pure water applications. See the products data sheets for Model 3081C/81C or Model 1054B LC for these applications.

TABLE 8-1. Local Interface Functions

<ul style="list-style-type: none"> • Display output in mA/% of full scale • Hold output mode • Set 4-20 mA output range • Display temperature in °C/°F • Input or display cell constant • Display cell factor • Electronic zero 	<ul style="list-style-type: none"> • Auto/manual temperature compensation • Two point calibration • Standardize temperature • Standardize conductivity • Input or display temperature slope • Display absolute conductivity
--	---

TABLE 8-2. Measurement Ranges

Type Sensor	Maximum Range	Switch Setting
Toroidal	Below 400,000µS x Cell Constant Above 400,000µS x Cell Constant	Both "Lo" Both "Hi"
Contacting	Below 4,000µS x Cell Constant Above 4,000µS x Cell Constant	Both "Lo" Both "Hi"

Operating Ranges for Various Contacting Cells Constants (not to scale)

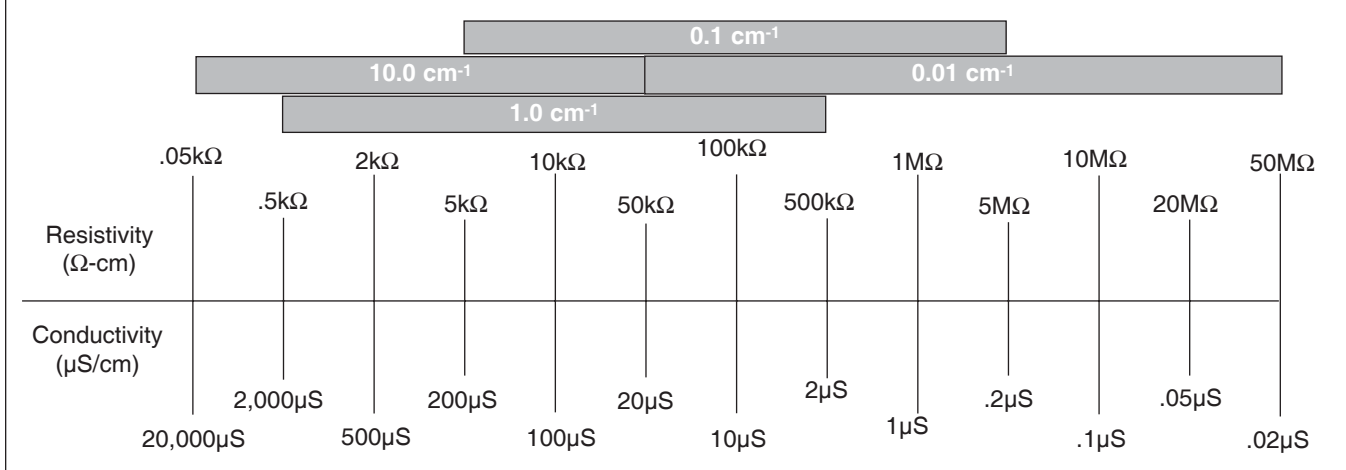

8.4 PHYSICAL SPECIFICATIONS

Electrical Connections: 1/2 in. NPT.

Model 275 SMART FAMILY Interface connections permanently fixed to terminal block. The terminal block also has removable connectors for bare wire sensor connections.

Housing: Epoxy-polyester painted over low coppercast aluminum. BUNA-N O-rings on cover.

Recommended Cable: Transmitter to power supply two-wire, 18 AWG, shielded, Belden 8760 or equal (Rosemount Analytical PN 9200001).

Weight/Shipping Weight: 2.18 kg/2.68 kg (4.8 lb/5.9 lb)

Hazardous Area Classification:

FM Certification:

Type	Class	Div.	Groups
I.S.	I, II, III	I	ABCDEFGH
Dust/Ignition	II, III	I	EFG
N.I.	I	2	ABCD

CENELEC Certification*:

Contacting Conductivity-

I.S. EEXia IIC T5 (Tamb = 40°C) or
EEXia IIC T4 (Tamb = 70°C)

Toroidal Conductivity- I.S. same specifications

* user must specify sensor type in order to receive an Intrinsicly safe loop

**8.5 RECOMMENDED SENSORS:
(CONTACTING)**

Model 140 Retractable Conductivity

Model 141/142 Insertion Conductivity

Model 150 Insertion/Submersion Conductivity

Model 400 Screw-In Low Conductivity

Model 401 Screw-In High Conductivity

	INDUCTIVE	FULL SCALE	
		Minimum	Maximum
Model 222 Sensor	0-500 µS/cm	0-2000 mS/cm	
Model 226 Sensor	0-50 µS/cm	0-1000 mS/cm	
Model 225 Sensor	0-250 µS/cm	0-2000 mS/cm	
Model 228 Sensor	0-250 µS/cm	0-2000 mS/cm	

CONTACTING SENSORS				
Conductivity Sensor Model Number	142 400 402/403/404	142 150 400/402/403/404	140, 141 150 400/402/403	401-14 402/403
Cell Constant	0.01	0.1	1.0	10.0

NOTE: Not applicable for conductivity less than 10 mS/cm. For these applications, please see product data sheets for Models 1054BLC, 1055C, or 3081/81C.

INDUCTIVE SENSORS					
Conductivity Sensor Model Number	226	228	225	222 (1in.)	222 (2 in.)
Cell Constant*	1.0	3.0	3.0	6.0	4.0
Minimum Range	50	250	250	500	500
Maximum Range	1,000,000	2,000,000	2,000,000	2,000,000	2,000,000
* Typical	FULL SCALE MICROSIEMENS/cm				

8.6 ORDERING INFORMATION

Model 2081C/T conductivity Two-Wire Transmitter is compatible with both contacting and inductive conductivity sensors (indicate sensor type if known). It is housed in a NEMA 4X (IP65) weatherproof, corrosion-resistant enclosure suitable for pipe mounting. Standard features include HART digital communications capability, LCD digital display, isolated 4-20 mA output, and automatic temperature compensation.

MODEL	
2081	HART SMART TWO-WIRE CONDUCTIVITY TRANSMITTER
Code	Input (Required selection)
C	Contacting Conductivity
T	Toroidal Conductivity
Code	Options
11	Stainless steel tag (specify marking)
Code	Agency Approvals
67	FM approved, Intrinsically Safe (when used with approved sensor and safety barrier) and explosion-proof, Contacting and Toroidal
69	CSA approved, Intrinsically Safe (when used with approved sensor and safety barrier) and explosion-proof, Contacting and Toroidal
73	CENELEC approved, Intrinsically Safe (safety barrier required), Contacting and Toroidal
2081C/T	67 EXAMPLE

8.7 ACCESSORIES

PN	DESCRIPTION	RECOMMENDED SPARES
23419-00	PCB, 2081 LCD Display	1
23533-00	PCB, 2081 Interface	
23421-02	PCB Stack, 2081C (CPU/Sensor loop and display)	1
23421-03	PCB Stack, 2081T (Sensor loop and display)	
23519-00	Push Buttons, 2081, Kit	1
33197-00	Enclosure, Middle	
2002518	Enclosure Cover, LCD Display Side	
2002577	Pipe Mounting Bracket	
2002603	O-ring Kit (Qty 2), Window	
2002604	O-ring Kit (Qty 2), Enclosure	2
3002468	Enclosure Cover, Tall	
9200001	Cable, 2 Conductor, 18 AWG, Shielded	
9240008-00	Overlay, 2081pH LCD Display	1
9240864	Stainless steel tag (formerly Code -07)	

```

1 PROCESS VARIABLES---1 VIEW FLD DEV VARS- 1 (G)
|                                     | 2 (Temp)
|                                     | 3 (AC)
|                                     |
|                                     | 2 VIEW PV-ANALOG 1-- 1 (PV is)
|                                     | 2 (PV)
|                                     | 3 (PV % rng)
|                                     | 4 (PV AO)
|                                     |
|                                     | 3 (View status)
|
2' DIAG/SERVICE-----1 (View status)
| 2 (Loop test)
| 3 CALIBRATION-----1 STANDARDIZE COND-- 1 (Begin procedure)
|                                     | 2 (C)
|                                     | 3 (Cell const)
|                                     | 4 (Cell factor)
|                                     |
|                                     | 2 INITIAL SETUP----- 1 (Cell const)
|                                     | 2 (Sensor zero)
|                                     | 3 TEMP SLOPE CAL---- 1 (Begin procedure)
|                                     | 2 (Slope)
|                                     | 3 (C)
|                                     | 4 (Cell const)
|                                     | 5 (Cell factor)
|                                     |
|                                     | 3 ADJUST TEMPERATURE 1 (Begin procedure)
|                                     | 2 (Temp)
|                                     | 3 (Temp comp)
|                                     | 4 (Man. temp)
|
| 4 (Trim analog output)
|
3 BASIC SETUP-----1 (Tag)
| 2 PV RANGE VALUES--- 1 (LRV)
|                                     | 2 (URV)
|                                     | 3 (PV Damp)
|                                     | 4 (PV)
|                                     | 5 (PV % rng)
|                                     | 6 (Xfer fun)
|
| 3 DEVICE INFORMATION 1 (Tag)
|                                     | 2 (Descriptor)
|                                     | 3 (Message)
|                                     | 4 (Snsr text)
|                                     | 5 (Date)
|
4 DETAILED SETUP-----1 SENSORS----- 1 (Cell const)
|                                     | 2 (Cell factor)
|                                     | 3 (Slope)
|                                     | 4 (Temp comp)
|                                     | 5 (Man. temp)
|
| 2 SIGNAL CONDITION-- 1 (LRV)
|                                     | 2 (URV)
|                                     | 3 (PV Damp)
|                                     | 4 (PV)
|                                     | 5 (PV % rng)
|                                     | 6 (Xfer fun)
|
| 3 OUTPUT CONDITION-- 1 ANALOG OUTPUT---- 1 (PV AO)
|                                     | 2 (Loop test)
|                                     | 3 (Trim analog output)
|                                     |
|                                     | 2 HART OUTPUT----- 1 (Poll addr)
|                                     | 2 (Temp unit)
|                                     | 3 (Burst option)
|                                     | 4 (Burst mode)
|                                     | 5 (Num resp preams)
|
| 4 DEVICE INFORMATION 1 (Tag)
|                                     | 2 (Descriptor)
|                                     | 3 (Message)
|                                     | 4 (Snsr text)
|                                     | 5 (Date)
|
5 REVIEW-----1 SENSORS
| 2 OUTPUTS
| 3 DEVICE INFORMATION
    
```

FIGURE 8-2. MODEL 275 HART COMMUNICATION MENU TREE- MODEL 2081C

SECTION 9.0 RETURN OF MATERIAL

9.1 GENERAL.

To expedite the repair and return of instruments, proper communication between the customer and the factory is important. Call 1-949-757-8500 for a Return Materials Authorization (RMA) number.

9.2 WARRANTY REPAIR.

The following is the procedure for returning instruments still under warranty:

1. Call Rosemount Analytical for authorization.
2. To verify warranty, supply the factory sales order number or the original purchase order number. In the case of individual parts or sub-assemblies, the serial number on the unit must be supplied.
3. Carefully package the materials and enclose your "Letter of Transmittal" (see Warranty). If possible, pack the materials in the same manner as they were received.
4. Send the package prepaid to:

Rosemount Analytical Inc., Uniloc Division
Uniloc Division
2400 Barranca Parkway
Irvine, CA 92606

Attn: Factory Repair

RMA No. _____

Mark the package: Returned for Repair

Model No. _____

9.3 NON-WARRANTY REPAIR.

The following is the procedure for returning for repair instruments that are no longer under warranty:

1. Call Rosemount Analytical for authorization.
2. Supply the purchase order number, and make sure to provide the name and telephone number of the individual to be contacted should additional information be needed.
3. Do Steps 3 and 4 of Section 9.2.

NOTE

Consult the factory for additional information regarding service or repair.

WARRANTY

Seller warrants that the firmware will execute the programming instructions provided by Seller, and that the Goods manufactured or Services provided by Seller will be free from defects in materials or workmanship under normal use and care until the expiration of the applicable warranty period. Goods are warranted for twelve (12) months from the date of initial installation or eighteen (18) months from the date of shipment by Seller, whichever period expires first. **Consumables, such as glass electrodes, membranes, liquid junctions, electrolyte, o-rings, catalytic beads, etc., and Services are warranted for a period of 90 days from the date of shipment or provision.**

Products purchased by Seller from a third party for resale to Buyer ("Resale Products") shall carry only the warranty extended by the original manufacturer. Buyer agrees that Seller has no liability for Resale Products beyond making a reasonable commercial effort to arrange for procurement and shipping of the Resale Products.

If Buyer discovers any warranty defects and notifies Seller thereof in writing during the applicable warranty period, Seller shall, at its option, promptly correct any errors that are found by Seller in the firmware or Services, or repair or replace F.O.B. point of manufacture that portion of the Goods or firmware found by Seller to be defective, or refund the purchase price of the defective portion of the Goods/Services.

All replacements or repairs necessitated by inadequate maintenance, normal wear and usage, unsuitable power sources, unsuitable environmental conditions, accident, misuse, improper installation, modification, repair, storage or handling, or any other cause not the fault of Seller are not covered by this limited warranty, and shall be at Buyer's expense. Seller shall not be obligated to pay any costs or charges incurred by Buyer or any other party except as may be agreed upon in writing in advance by an authorized Seller representative. All costs of dismantling, reinstallation and freight and the time and expenses of Seller's personnel for site travel and diagnosis under this warranty clause shall be borne by Buyer unless accepted in writing by Seller.

Goods repaired and parts replaced during the warranty period shall be in warranty for the remainder of the original warranty period or ninety (90) days, whichever is longer. This limited warranty is the only warranty made by Seller and can be amended only in a writing signed by an authorized representative of Seller. Except as otherwise expressly provided in the Agreement, THERE ARE NO REPRESENTATIONS OR WARRANTIES OF ANY KIND, EXPRESS OR IMPLIED, AS TO MERCHANTABILITY, FITNESS FOR PARTICULAR PURPOSE, OR ANY OTHER MATTER WITH RESPECT TO ANY OF THE GOODS OR SERVICES.

RETURN OF MATERIAL

Material returned for repair, whether in or out of warranty, should be shipped prepaid to:

**Emerson Process Management
Liquid Division
2400 Barranca Parkway
Irvine, CA 92606**

The shipping container should be marked:

Return for Repair

Model _____

The returned material should be accompanied by a letter of transmittal which should include the following information (make a copy of the "Return of Materials Request" found on the last page of the Manual and provide the following thereon):

1. Location type of service, and length of time of service of the device.
2. Description of the faulty operation of the device and the circumstances of the failure.
3. Name and telephone number of the person to contact if there are questions about the returned material.
4. Statement as to whether warranty or non-warranty service is requested.
5. Complete shipping instructions for return of the material.

Adherence to these procedures will expedite handling of the returned material and will prevent unnecessary additional charges for inspection and testing to determine the problem with the device.

If the material is returned for out-of-warranty repairs, a purchase order for repairs should be enclosed.



*The right people,
the right answers,
right now.*

**ROSEMOUNT ANALYTICAL
CUSTOMER SUPPORT CENTER
1-800-854-8257**



ON-LINE ORDERING NOW AVAILABLE ON OUR WEB SITE
<http://www.raihome.com>



Credit Cards for U.S. Purchases Only.



Emerson Process Management

Rosemount Analytical Inc.

2400 Barranca Parkway
Irvine, CA 92606 USA
Tel: (949) 757-8500
Fax: (949) 474-7250

<http://www.raihome.com>



Free Manuals Download Website

<http://myh66.com>

<http://usermanuals.us>

<http://www.somanuals.com>

<http://www.4manuals.cc>

<http://www.manual-lib.com>

<http://www.404manual.com>

<http://www.luxmanual.com>

<http://aubethermostatmanual.com>

Golf course search by state

<http://golfingnear.com>

Email search by domain

<http://emailbydomain.com>

Auto manuals search

<http://auto.somanuals.com>

TV manuals search

<http://tv.somanuals.com>