

Emerson™
Bluetooth® Wireless Headset
EM225/EM226
Operating Instructions

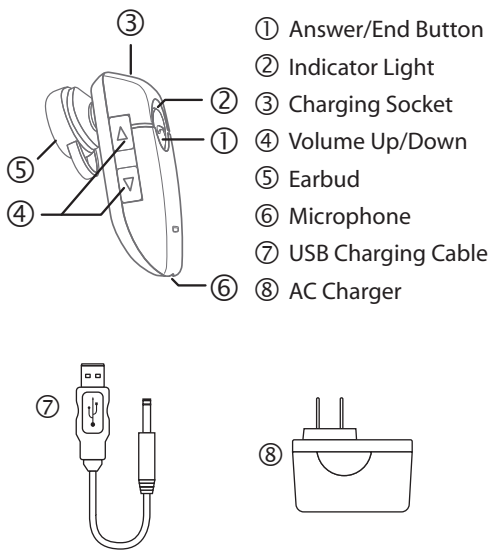

Charging the Battery

- 1) Connect the USB cable to the charging socket on the headset.
- 2) Connect the other end of the USB Cable to the:
 - **AC Charger**, and plug into a wall (A/C) outlet
 - **Computer's USB port**
- 3) The indicator light will show RED.
- 4) RED light shuts off when the unit is 60% charged. To fully charge the headset 4 hours of charging is required.

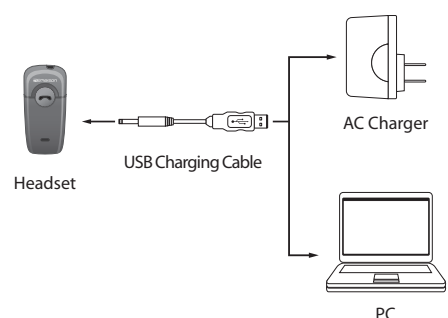

Switching the Headset Power ON/OFF

To power on:
 Press and hold the ① [ANSWER/END] button until the blue indicator light turns on.

To power off:
 Press and hold the ① [ANSWER/END] button until the indicator light turns red, and shuts off.

Pairing the Headset with a Bluetooth Enabled Phone

- 1) Make sure the headset is turned off.
- 2) Press and hold the ① [ANSWER/END] button until the RED and BLUE lights flash alternately.

*This will require pressing and holding the ① [ANSWER/END] button longer than when turning the unit ON or OFF.

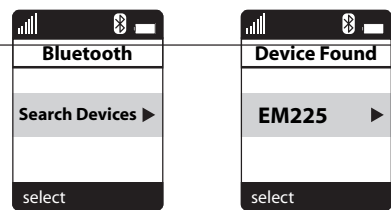

- 3) Set the phone to search for bluetooth devices.
- 4) When the phone finds the headset, confirm by selecting EM225/EM226 from the list.

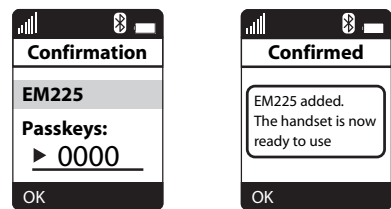

- 5) Enter passcode "0000" when prompted by the phone.
- 6) If the pairing is successful, the indicator light flashes a low steady blue. You are now ready to make and receive calls.

Answer/Ending a Call

Tap the ① [ANSWER/END] button.

To Make a Call

Dial the number and press the send button from your phone, the call is automatically transferred to the headset.

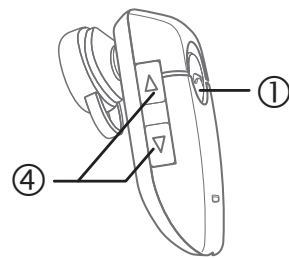

Adjusting the Volume

You may adjust the volume by using ④ [Volume Up/Down] buttons on the headset, or adjust from your phone's volume control button.

Ear Hook



Left Ear Right Ear
 Fits either ear comfortably

LIMITED WARRANTY

In the unlikely event that this product is defective, or does not perform properly, you may within ninety (90) days from your original date of purchase return it to the authorized service center for repair or exchange.

TO OBTAIN WARRANTY SERVICE:
 - Provide proof of the date of purchase within the package (Dated bill of sale)
 - Prepay all shipping costs to the authorized service center, and remember to insure your return.
 - Include a return shipping address (no P.O. Boxes), a telephone contact number, and the defective unit within the package.
 - Describe the defect or reason you are returning the product.

Your product will be repaired or replaced, at our option, for the same or similar model of equal value if examination by the service center determines this product to be defective. Products received damaged, as a result of shipping will require you to file a claim with the carrier.

The shipping address of the authorized service center is:

Southern Telecom Inc.
 ATTENTION: Returns Department
 14-C 53rd Street
 Brooklyn, NY 11232

Should you have any questions or problems concerning this product, please contact our customer service department at:

1-877-768-8483
 Mon – Fri: 9AM – 5PM (EST)
 or
 via e-mail at cs@emersonphones.com.

To obtain service after the warranty period, please e-mail cs@emersonphones.com with product information, date of purchase and nature of the problem. Customer service will reply to the e-mail with service instructions.

Warranty service not provided

This warranty does not cover damage resulting from accident, misuse, abuse, improper installation or operation, lack of reasonable care, and unauthorized modification. This warranty is voided in the event any unauthorized person opens, alters or repairs this product. All products being returned to the authorized service center for repair must be suitably packaged.

Limitation of Warranty:

• THE WARRANTY STATED ABOVE IS THE ONLY WARRANTY APPLICABLE TO THIS PRODUCT. ALL OTHER WARRANTIES, EXPRESS OR IMPLIED (INCLUDING ALL IMPLIED WARRANTIES OF MERCHANTABILITY OR FITNESS FOR A PARTICULAR PURPOSE) ARE HEREBY DISCLAIMED. NO VERBAL OR WRITTEN INFORMATION GIVEN BY SOUTHERN TELECOM INC. ITS AGENTS, OR EMPLOYEES SHALL CREATE A WARRANTY OR IN ANY WAY INCREASE THE SCOPE OF THIS WARRANTY.

• REPAIR OR REPLACEMENT AS PROVIDED UNDER THIS WARRANTY IS THE EXCLUSIVE REMEDY OF THE CONSUMER. SOUTHERN TELECOM INC. SHALL NOT BE LIABLE FOR INCIDENTAL OR CONSEQUENTIAL DAMAGES RESULTING FROM THE USE OF THIS PRODUCT OR ARISING OUT OF ANY BREACH OF ANY EXPRESS OR IMPLIED WARRANTY ON THIS PRODUCT. THIS DISCLAIMER OF WARRANTIES AND LIMITED WARRANTY ARE GOVERNED BY THE LAWS OF THE STATE OF NEW YORK. EXCEPT TO THE EXTENT PROHIBITED BY APPLICABLE LAW, ANY IMPLIED WARRANTY OF MERCHANTABILITY OR FITNESS FOR A PARTICULAR PURPOSE ON THIS PRODUCT IS LIMITED TO THE APPLICABLE WARRANTY PERIOD SET FORTH ABOVE.

How state law relates to this warranty:

• Some states do not allow the exclusion nor limitation of incidental, consequential damages, or limitations on how long an implied warranty lasts so the above limitations or exclusion may not apply to you.

• This warranty gives you specific legal rights, and you also may have other rights that vary from state to state.

Made in China / Designed in USA

Distributed by: AIT Inc. Brooklyn NY, 11232

Emerson and the G-Clef logo are registered trademarks of Emerson Radio Corp., Parsippany, New Jersey USA.

© 2008 AIT Inc. All rights reserved.

The Bluetooth® word mark and logos are owned by the Bluetooth SIG, Inc.

FCC Compliance

NOTE: This equipment has been tested and found to comply with the limits for a Class B digital device, pursuant to Part 15 of the FCC Rules. These limits are designed to provide reasonable protection against harmful interference in a residential installation. This equipment generates, uses and can radiate radio frequency energy and, if not installed and used in accordance with the instructions, may cause harmful interference to radio communications. However, there is no guarantee that interference will not occur in a particular installation. If this equipment does cause harmful interference to radio or television reception, which can be determined by turning the equipment off and on, the user is encouraged to try to correct the interference by one or more of the following measures:

- Reorient or relocate the receiving antenna.
- Increase the separation between the equipment and receiver.
- Connect the equipment into an outlet on a circuit different from that to which the receiver is connected.
- Consult the dealer or an experienced radio/TV technician for help.

Any changes or modifications not expressly approved by the party responsible for compliance could void the user's authority to operate the equipment.

No special accessory is required to enable the equipment to comply with the emission limits.

This device complies with Part 15 of the FCC Rules. Operation is subject to the following two conditions:

- (1) This device may not cause harmful interference, and
- (2) This device must accept any interference received, including interference that may cause undesired operation.

Free Manuals Download Website

<http://myh66.com>

<http://usermanuals.us>

<http://www.somanuals.com>

<http://www.4manuals.cc>

<http://www.manual-lib.com>

<http://www.404manual.com>

<http://www.luxmanual.com>

<http://aubethermostatmanual.com>

Golf course search by state

<http://golfingnear.com>

Email search by domain

<http://emailbydomain.com>

Auto manuals search

<http://auto.somanuals.com>

TV manuals search

<http://tv.somanuals.com>