



Big Button Speakerphone

Model EM300

FCC and Telephone Company Information

Your telephone equipment is approved for connection to the Public Switched Telephone Network and is in compliance with parts 15 and 68, FCC Rules and Regulations and the Technical Requirements for Telephone Terminal Equipment published by ACTA.

FCC Part 15

This equipment has been tested and found to comply with the requirements for a Class B digital device under Part 15 of the Federal Communications Commission (FCC) rules. These requirements are intended to provide reasonable protection against harmful interference in a residential installation. This equipment generates, uses and can radiate radio frequency energy and, if not installed and used in accordance with the instructions, may cause harmful interference to radio communications. However, there is no guarantee that interference will not occur in a particular installation. If this equipment does cause harmful interference to radio or television reception, which can be determined by turning the equipment off and on, the user is encouraged to try to correct the interference by one or more of the following measures:

- Re-orient or relocate the antenna.
- Increase the separation between the equipment and receiver.
- Connect the equipment into an outlet on a circuit different from that to which the receiver is connected.
- Consult the dealer or an experienced radio/TV technician for help.

Changes or modifications to this equipment not expressly approved by the party responsible for compliance could void the user's authority to operate the equipment.

FCC Part 68 and ACTA

This equipment complies with Part 68 of the FCC rules and with technical requirements adopted by the Administrative Council for Terminal Attachments (ACTA). The label on the back or bottom of this equipment contains, among other things, a product identifier in the format US: AAEEQ##TXXXX. This identifier must be provided to your local telephone company upon request.

The plug and jack used to connect this equipment to premises wiring and the telephone network must comply with applicable Part 68 rules and technical requirements adopted by ACTA. A compliant telephone cord and modular plug is provided with this product. It is designed to be connected

FCC and Telephone Company Information (Cont.)

to a compatible modular jack that is also compliant. An RJ11 jack should normally be used for connecting to a single line and an RJ14 jack for two lines.

The Ringer Equivalence Number (REN) is used to determine how many devices you may connect to your telephone line and still have them ring when you are called. The REN for this product is encoded as the 6th and 7th characters following the US: in the product identifier (e.g., if ## is 03, the REN is 0.3). In most, but not all areas, the sum of all RENs should be five (5.0) or less. For more information, please contact your local telephone company.

This equipment may not be used with Party Lines. If you have specially wired alarm dialing equipment connected to your telephone line, ensure the connection of this equipment does not disable your alarm equipment. If you have questions about what will disable alarm equipment, consult your telephone company or a qualified installer.

If this equipment is malfunctioning, it must be unplugged from the modular jack until the problem has been corrected. Repairs to this telephone equipment can only be made by the manufacturer or its authorized agents. For repair procedures, follow the instructions outlined under the Limited Warranty.

If this equipment is causing harm to the telephone network, the telephone company may temporarily discontinue your telephone service. The telephone company is required to notify you before interrupting service. If advance notice is not practical, you will be notified as soon as possible. You will be given the opportunity to correct the problem and the telephone company is required to inform you of your right to file a complaint with the FCC. Your telephone company may make changes in its facilities, equipment, operation, or procedures that could affect the proper functioning of this product. The telephone company is required to notify you if such changes are planned.

This telephone system meets FCC Standards for Hearing Aid Compatibility.

WARNING:

TO PREVENT FIRE OR ELECTRICAL SHOCK HAZARD, DO NOT EXPOSE THIS PRODUCT TO RAIN OR MOISTURE.

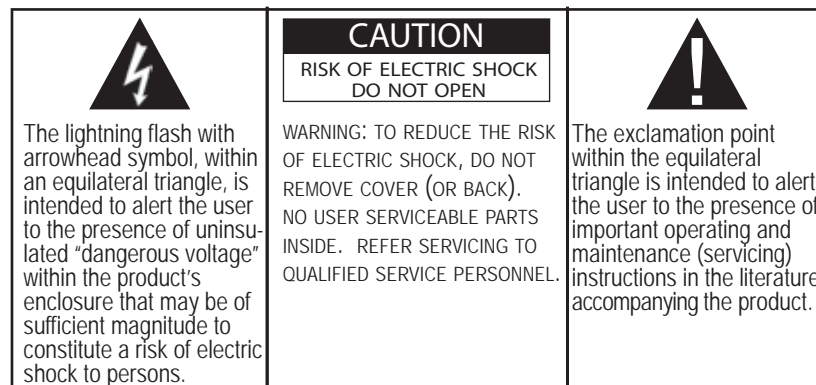

Rating plate and caution marking are marked on the bottom enclosure of the apparatus.

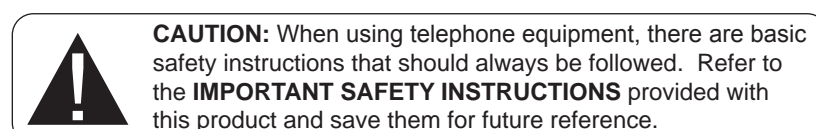

Important Safety Instructions

* Some of the below precautions may not apply to your product, e.g.: Battery and power cord precautions.

When using your telephone equipment, basic safety precautions should always be followed to reduce the risk of fire, electric shock and injury, including the following:

1. Read and understand all instructions.
2. Follow all warnings and instructions marked on the product.
3. Unplug this product from the wall outlet before cleaning. Do not use liquid or aerosol cleaners. Use a damp cloth for cleaning.
4. Do not use this product near water (for example, near a bath tub, kitchen sink or swimming pool).
5. Do not place this product on an unstable surface, such as a table, shelf or stand. The product may fall, causing serious damage.
6. Slots and openings in the back or bottom of the telephone base and handset are provided for ventilation. To protect them from overheating, these openings must not be blocked by placing the product on a soft surface such as a bed, sofa or rug. This product should never be placed near or over a radiator or heat register. This product should not be placed in any area where proper ventilation is not provided.
7. Use only the power cord and batteries indicated in this manual.
8. This product should be operated only from the type of power source indicated on the marking label. If you are not sure of the type of power supply in your home, consult your dealer or local power company.
9. Plug the adaptor to the socket - outlet that is closest to the equipment and which is easily accessible.
10. Do not allow anything to rest on the power cord. Do not install this product

Important Safety Instructions (Cont.)

where the cord may have anyone walking on it.

11. Never push objects of any kind into this product through slots in the telephone base or handset as they may touch dangerous voltage points or create a short circuit that could result in a risk of fire or electric shock. Never spill liquid of any kind on the product.
12. To reduce the risk of electric shock, do not disassemble this product, but take it to an authorized service facility. Opening or removing parts of the telephone base or handset other than specified access doors may expose you to dangerous voltages or other risks. Incorrect reassembling can cause electric shock when the product is subsequently used.
13. Do not overload wall outlets and extension cords as this can result in the risk of fire or electric shock.
14. The power adapter is intended to be correctly oriented in a vertical or floor mount position. The prongs are not designed to hold the plug in place if it is plugged into a ceiling or an under-the-table/cabinet outlet.
15. Unplug this product from the wall outlet and refer servicing to an authorized service facility under the following conditions:
 - A. When the power supply cord or plug is damaged or frayed.
 - B. If liquid has been spilled onto the product.
 - C. If the product has been exposed to rain or water.
 - D. If the product does not operate normally by following the operating instructions. Adjust only those controls that are covered by the operating instructions, as improper adjustment of other controls may result in damage and often requires extensive work by an authorized technician to restore the product to normal operation.
 - E. If the product has been dropped and the telephone base and/or handset has been damaged.
 - F. If the product exhibits a distinct change in performance.
16. Avoid using a telephone (other than cordless) during an electrical storm. There is a remote risk of electric shock from lightning.
17. Do not use the telephone to report a gas leak in the vicinity of the leak.
18. Do not dispose of batteries in a fire. They may explode. Check with local codes for possible special disposal instructions.

SAVE THESE INSTRUCTIONS

Important Installation Information

- Never install telephone wiring during a lightning storm.
- Never touch uninsulated telephone wires or terminals, unless the telephone line has been disconnected at the network interface.
- Use caution when installing or modifying telephone lines.
- Never install telephone jacks in wet locations unless the jack is specifically designed for wet locations.
- Temporarily disconnect any equipment connected to the phone, such as faxes, other phones, or modems.



CAUTION: Disconnect the phone cord from the wall outlet before installing or replacing the batteries. (Only for telephones which require batteries)

Installation

1. Place your telephone on a hard, flat surface.
2. Insert the modular plugs of the coil handset cord into the jack of the telephone handset and into the jack marked "TO HANDSET" at the side of the telephone base (Figure 1).
3. Insert the straight-line cord into the modular jack at the back of the telephone marked "TO WALL JACK". (Figure 1)

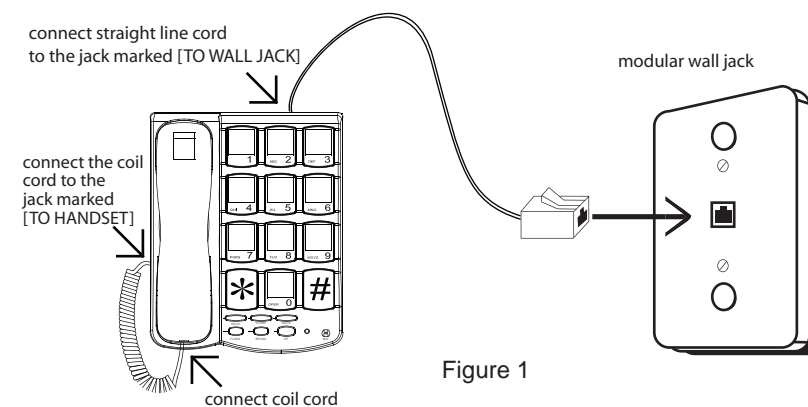

Figure 1

4. Make sure all plugs snap firmly in place.
5. Pick up the handset and confirm you hear the dial tone.

Wall Mount Installation

To mount your telephone on a wall plate (not included), connect the mounting bracket to the back of the base (Figure 2), and plug the straight line cord into a modular wall phone jack. Align the holes on the base with the mounting studs on the wall plate, and pull the base down onto the studs until the telephone is secure.

Installation (Cont.)

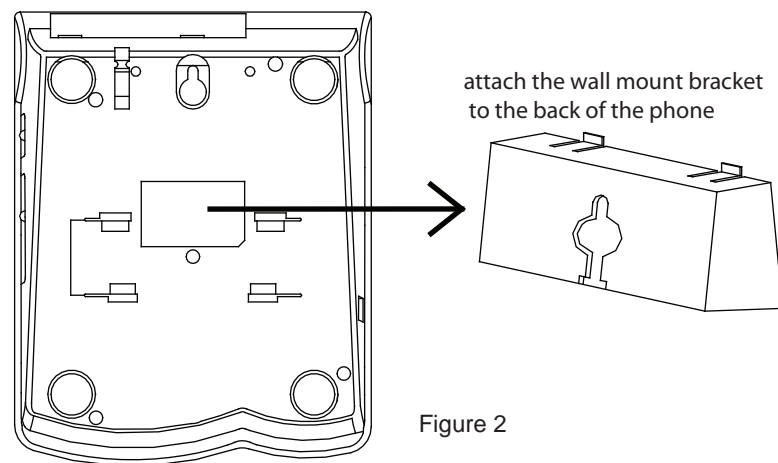
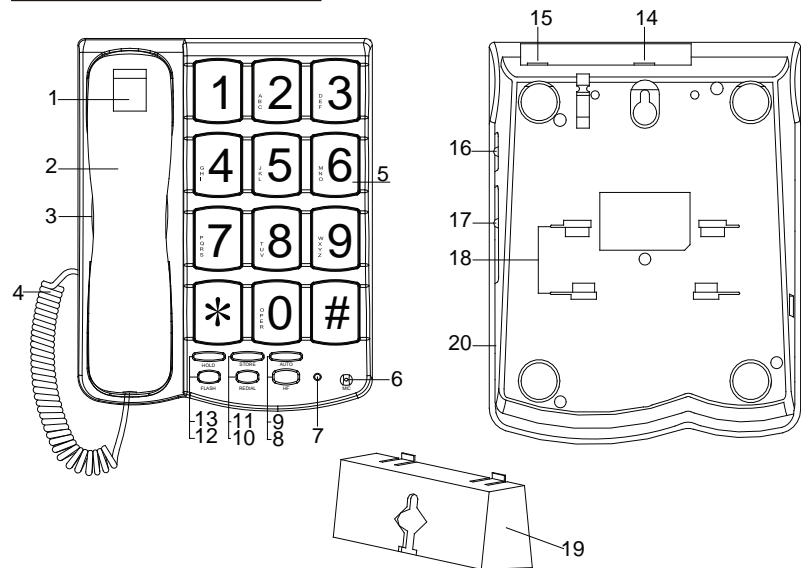

Figure 2

Location of controls



- | | |
|----------------------------|--|
| 1 - Hook switch | 11 - Store |
| 2 - Handset | 12 - Flash |
| 3 - Speaker | 13 - Hold |
| 4 - Coil cord | 14 - Line jack |
| 5 - Numeric keypad | 15 - Ringer ON/OFF switch |
| 6 - Mic | 16 - Handset volume Hi/Mid/Low control |
| 7 - In use indicator light | 17 - Speaker volume control |
| 8 - HF (speakerphone) | 18 - Mountable wall bracket slots |
| 9 - Auto (memory dialing) | 19 - Mountable wall bracket |
| 10 - Redial | 20 - Headset jack |

Telephone Operation

- **Handset Volume** - Adjust the [**HANDSET VOLUME**] switch to the LO/MID/HI position.
- **Ringer On/Off** - To avoid being disturbed by the ringer during incoming calls, slide the [**RINGER ON/OFF**] switch to the OFF position.
- **In use Indicator** - Indicator lights when the phone is in use.
- **Flash** - Press the [**FLASH**] button to activate services such as call waiting or call transfer. You must subscribe to these services from your local phone company.
- **Redial** - To redial the last number you called, pick up the handset and press the [**REDIAL**] button.
- **Hold** - Press the [**HOLD**] button to temporarily put a caller on hold. Press the [**HOLD**] button again to continue the conversation.
- **Headset jack** - Connect a 2.5 mm compatible headset with mic for private handsfree conversations.

Memory Dialing

This telephone can store up to 10 phone numbers (up to 16 digits), which will remain stored in memory unless you erase or change them by entering other numbers, or unplug your telephone from the wall jack.

To Program Numbers Into Memory

1. Lift the handset.
2. Press the [**STORE**] button.
3. Dial the number you would like to store (up to 16 digits).
4. Press the [**STORE**] button.
5. Enter a digit [**0 - 9**] for the memory location where you want to store the number.

To Dial Out From Memory

1. Lift the handset and listen for the dial tone.
2. Press the [**AUTO**] button, and then press the memory location [**0 - 9**].
3. The number stored in that location will be dialed automatically.

Troubleshooting Tips

- **No dial tone** - Check to see if your phone is properly connected to the modular wall jack. (Refer to **Installing Your Telephone**).
- **Phone doesn't ring** - Make sure the [**RINGER ON/OFF**] switch (located at the back of the base) is set to the ringer ON position.
- **Handset volume is low** - Adjust the [**HANDSET VOLUME**] switch to the MID or HI position.
- **Speaker volume is low** - Adjust the [**SPEAKER VOLUME**] switch to the desired volume level.

Product Maintenance

Follow the guidelines below to properly maintain this product:

- Avoid putting it near heating appliances and devices that generate electrical noise (for example: motors or fluorescent lamps).
- DO NOT expose to direct sunlight or moisture.
- Avoid dropping the unit and/or other rough treatment.
- Clean with a soft cloth
- Never use a strong cleaning agent or abrasive powder because this will damage the finish.
- Retain the original packaging in case you need to ship it at a later date.

Warranty Information

1 Year Limited Warranty

In the unlikely event that this product is defective, or does not perform properly, you may within one (1) year from your original date of purchase return it to the authorized service center for repair or exchange.

TO OBTAIN WARRANTY SERVICE:

- **Provide proof of the date of purchase within the package (Dated bill of sale).**
- **Prepay all shipping costs to the authorized service center, and remember to insure your return.**
- **Include a return shipping address (no P.O. Boxes), a telephone contact number, and the defective unit within the package.**
- **Describe the defect or reason you are returning the product.**

Your product will be repaired or replaced, at our option, for the same or similar model of equal value if examination by the service center determines this product is defective. Products received damaged as a result of shipping will require you to file a claim with the carrier.

The shipping address of the authorized service center is:

Southern Telecom Inc.
ATTN: Returns Department
14-C 53rd Street
Brooklyn, NY 11232

Should you have any questions or problems concerning this product, please contact our customer service department, toll free at:

1-877-SOUTHTEL (1-877-768-8483)
Monday – Thursday: 9AM – 5PM (EST)
Friday: 9AM - 3PM (EST)

or via email at cs@southern telecom.com. To obtain service after the warranty period, please email cs@southern telecom.com with product information, date of purchase and nature of the problem. Customer service will reply to the email with service instructions.

Warranty service not provided

This warranty does not cover damage resulting from accident, misuse, abuse, improper installation or operation, lack of reasonable care, and unauthorized modification. This warranty is voided in the event any unauthorized person opens, alters or repairs this product. All products being returned to the authorized service center for repair must be suitably packaged.

Limitation of Warranty:

- THE WARRANTY STATED ABOVE IS THE ONLY WARRANTY APPLICABLE TO THIS PRODUCT. ALL OTHER WARRANTIES, EXPRESS OR IMPLIED (INCLUDING ALL IMPLIED WARRANTIES OF MERCHANTABILITY OR FITNESS FOR A PARTICULAR PURPOSE) ARE HEREBY DISCLAIMED. NO VERBAL OR WRITTEN INFORMATION GIVEN BY SOUTHERN TELECOM INC. IT'S AGENTS, OR EMPLOYEES SHALL CREATE A WARRANTY OR IN ANY WAY INCREASE THE SCOPE OF THIS WARRANTY.
- REPAIR OR REPLACEMENT AS PROVIDED UNDER THIS WARRANTY IS THE EXCLUSIVE REMEDY OF THE CONSUMER. SOUTHERN TELECOM INC. SHALL NOT BE LIABLE FOR INCIDENTAL OR CONSEQUENTIAL DAMAGES RESULTING FROM THE USE OF THIS PRODUCT OR ARISING OUT OF ANY BREACH OF ANY EXPRESS OR IMPLIED WARRANTY ON THIS PRODUCT. THIS DISCLAIMER OF WARRANTIES AND LIMITED WARRANTY ARE GOVERNED BY THE LAWS OF THE STATE OF NEW YORK. EXCEPT TO THE EXTENT PROHIBITED BY APPLICABLE LAW, ANY IMPLIED WARRANTY OF MERCHANTABILITY OR FITNESS FOR A PARTICULAR PURPOSE ON THIS PRODUCT IS LIMITED TO THE APPLICABLE WARRANTY PERIOD SET FORTH ABOVE

Warranty Information (Cont.)

Some states do not allow the exclusion nor limitation of incidental or consequential damages, or limitations on how long an implied warranty lasts so the above limitations or exclusions may not apply to you. This warranty gives you specific legal rights, and you also may have other rights that vary from state to state.

www.emersonphones.com
Manufactured by AIT Inc. Brooklyn NY. 11232
Emerson and the G-Clef logo are registered trademarks of Emerson Radio Corp. Parsippany, New Jersey USA.
© 2009 AIT Inc. All rights reserved.

Free Manuals Download Website

<http://myh66.com>

<http://usermanuals.us>

<http://www.somanuals.com>

<http://www.4manuals.cc>

<http://www.manual-lib.com>

<http://www.404manual.com>

<http://www.luxmanual.com>

<http://aubethermostatmanual.com>

Golf course search by state

<http://golfingnear.com>

Email search by domain

<http://emailbydomain.com>

Auto manuals search

<http://auto.somanuals.com>

TV manuals search

<http://tv.somanuals.com>