

Fisher™ CVX Steam Conditioning Valve

Contents

Introduction	1
Scope of Manual	1
Description	1
Educational Services	3
Principle of Operation	3
Installation	5
Maintenance	7
Servicing	10
Removal of Valve Bonnet and Trim	10
Nozzle Maintenance and Replacement	12
Valve Assembly	15
Parts Ordering	22
Parts List	22

Figure 1. Fisher CVX Steam Conditioning Valve

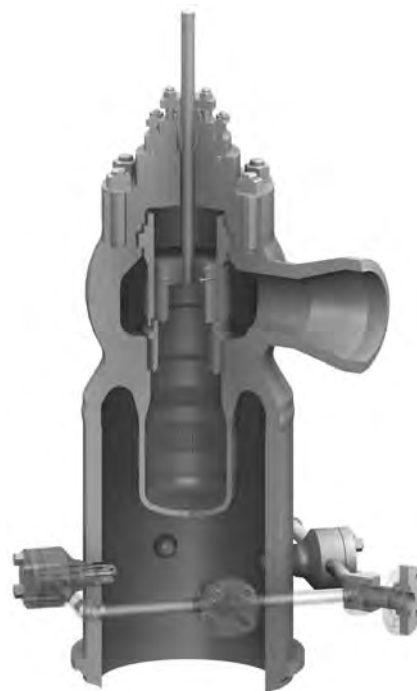

Introduction

Scope of Manual

This instruction manual includes installation, maintenance, and operation information for the Fisher CVX control valve. Refer to separate instruction manuals for instructions covering the actuator and accessories.



Do not install, operate, or maintain a CVX valve without being fully trained and qualified in valve, actuator, and accessory installation, operation, and maintenance. To avoid personal injury or property damage, it is important to carefully read, understand, and follow all the contents of this manual, including all safety cautions and warnings. If you have any questions about these instructions, contact your [Emerson sales office](#) before proceeding.

Description

The CVX Steam Conditioning Valve (see figure 1) provides a convenient and efficient way to reduce steam pressure and temperature within a single device. Typical installations include steam backpressure control, turbine bypass, boiler start-up service, auxiliary steam letdown for drying rolls, kettles, equipment drives, plant heating, and other loads requiring dependable and accurate control of steam pressure and temperature.

Table 1. Specifications

End Connection Sizes⁽¹⁾

Valve Inlet: NPS 4 through NPS 24
Valve Outlet: NPS 8 through NPS 60

End Connection Types

- ASME Buttweld (all sizes)
- ASME Raised Face Flanges (all sizes)
- ASME Ring Type Joint Flanges (all sizes)

Valve Configuration

Angle Pattern (flow down)

Valve Body Ratings⁽²⁾⁽⁴⁾

ASME: CL150 - CL2500

Bonnet Type

Bolted

Shutoff Classifications per ANSI/FCI 70-2 and IEC 60534-4

Class V: Standard
Class IV: Optional

Flow Characteristics⁽³⁾

Linear

Diffusers

Welded (permanent): Standard
Bolted (removable): Optional
Clamped Cartridge: Optional

Construction Materials

Body/Bonnet

- SA105 Carbon Steel
- SA182 Grade F22 (2-1/4 Cr-1 Mo)
- SA182 Grade F91 (9 Cr-1 Mo-V)
- SA182 Grade F92 (9 Cr-2 W-V)

Bonnet Bolting

- SA193 Grade B7
- SA193 Grade B16
- N07718

Diffuser

Welded (permanent)

- Carbon Steel
- 2-1/4 Cr-1 Mo
- 9 Cr-1 Mo-V
- 9 Cr-2 W-V

Bolted (removable)

- 2-1/4 Cr-1 Mo with N07718 Bolting
- 9 Cr-1 Mo-V with N07718 Bolting

Seat Ring

Welded Seat Ring

- Carbon Steel with Alloy 6
- 2-1/4 Cr-1 Mo with Alloy 6
- 9 Cr-1 Mo-V with Alloy 6
- 9 Cr-2 W-V with Alloy 6

Bolted Seat Ring

- 2-1/4 Cr-1 Mo with N07718 Bolting
- N06625 with N07718 Bolting
- N07718 with N07718 Bolting

Clamped Seat/Clamped Seat and Diffuser (optional)

- 2-1/4 Cr-1 Mo with Alloy 6 Seating Surfaces⁽¹⁾
- 9 Cr-1 Mo-V with Alloy 6 Seating Surfaces⁽²⁾

Control Plug:

- 2-1/4 Cr-1 Mo with Alloy 6 Guiding Surfaces
- 9 Cr-1 Mo-V with Alloy 6 Guiding Surfaces

Stem

- SA479 Type S20910
- N07718

Control Cage:

- 2-1/4 Cr-1 Mo Nitrided
- 9 Cr-1 Mo-V Nitrided

Piston Rings

- Alloy 6 with N07750 Expander

Bore Seal

- N07718

Gaskets

- *Bonnet:* N07750/Graphite
- *All Others:* N06600/Graphite

Packing

- Graphite/Flexible Graphite

Nozzles

- S41000 SST
- N07718

1. Standard end connection sizes. Alternate inlet and outlet sizes available for each valve body size to match piping requirements.

2. Not all valve sizes are available in all valve body ratings.

3. Contact your [Emerson sales office](#) for other flow characteristics.

4. Intermediate classes above CL2500 available upon request. PN pressure ratings available per pressure requirements of EN1092-1. Consult your Emerson sales office for additional options.

The CVX Steam Conditioning Valve (figure 1) is designed to handle moderate to severe applications in today's cycling power plants as well as provide precise pressure and temperature control for process applications. The CVX incorporates over 30 years of steam conditioning experience and product development. The valve body is designed with the latest finite element analysis (FEA) and computational fluid dynamics (CFD) tools to optimize performance and reliability for demanding steam systems.

The CVX valve design provides an exceptional combination of performance and maintainability. The simplified trim configuration is thermally compensated to handle rapid changes in temperatures, as expected during a turbine trip, without any sticking or binding.

Water atomization and vaporization are key elements in any steam conditioning application. The CVX incorporates a spraywater manifold of variable geometry Type AF nozzles producing a spray pattern suitable for high rangeability applications. These nozzles are strategically placed to achieve complete mixing and quick vaporization at all flowing conditions. Years of research in spray atomization and vaporization were key to optimizing the water injection system. Extensive use of CFD analysis, in addition to field performance feedback, was used to validate spray system enhancements.

Educational Services

For information on available courses for the Fisher CVX steam conditioning valve, as well as a variety of other products, contact:

Emerson Automation Solutions
Educational Services - Registration
Phone: 1-641-754-3771 or 1-800-338-8158
E-mail: education@emerson.com
emerson.com/fishervalvetraining

Principle of Operation

The positioning of the valve plug within the control cage controls the steam flow (see figure 1). The control cage has an array of orifices to provide the control characteristic specified. As the plug is lifted from the seat, steam is permitted to pass into the center of the control cage, and out through the seat orifice. A signal from the pressure control loop to the valve actuator moves the valve plug within the control cage, which increases or decreases the amount of free flow area. Retracting the plug increases steam flow.

The outlet section of the valve is comprised of a combination acoustical diffuser / cooler section. As the steam exits the seat orifice, it enters a diffuser section designed to further decrease steam pressure. Flow is directed radially, through the multiple orifice diffuser to the outlet pipe. The outlet section is fitted with cooling nozzles connected to a water manifold. This manifold provides cooling water flow to individual cooling nozzles installed in the pipe wall of the outlet section. The result is the creation of a fine spray mist injected into the highly turbulent outlet steam flow.

Figure 2. Typical Fisher CVX Installation

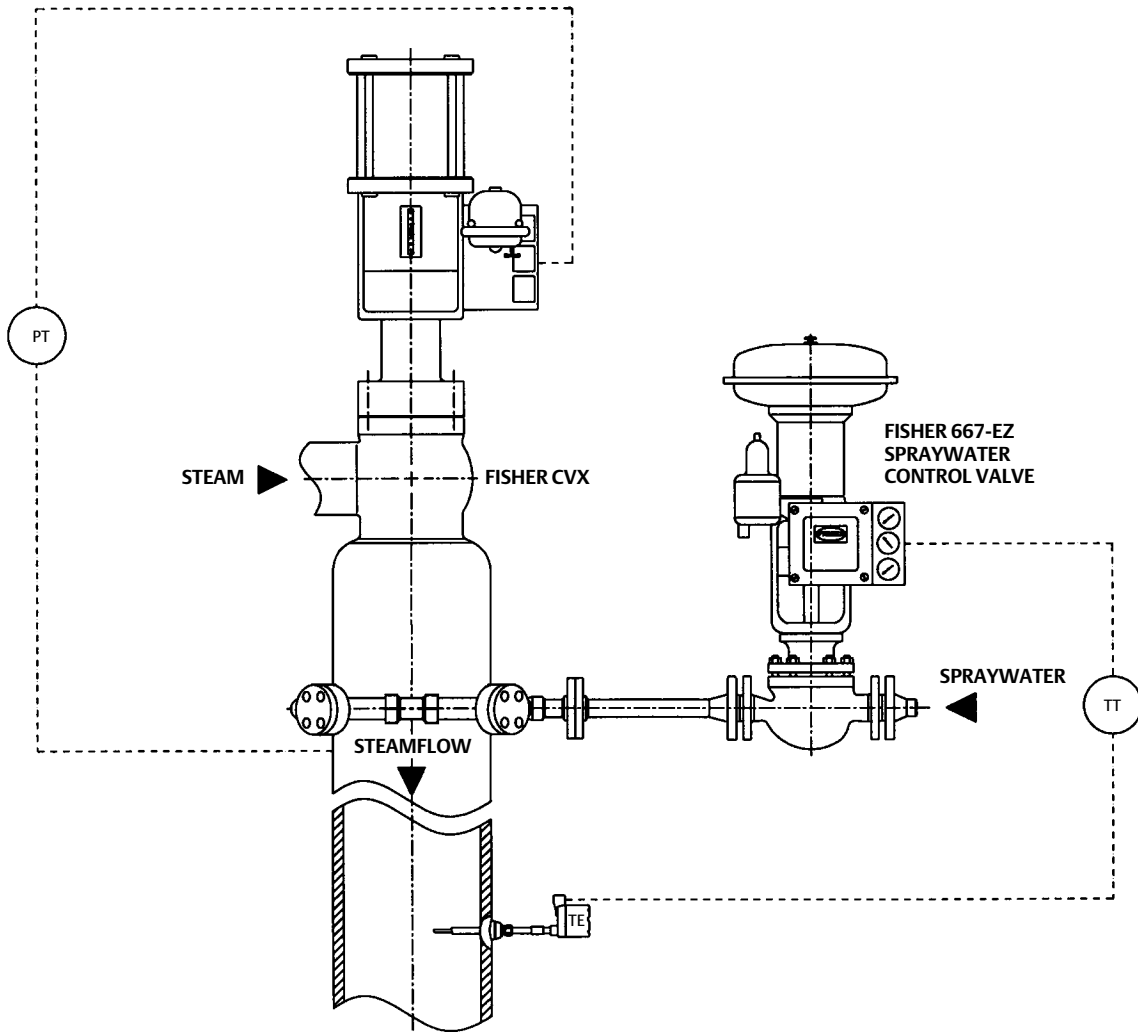

E1463

Installation

⚠ WARNING

Always wear protective gloves, clothing, and eyewear when performing any installation operations to avoid personal injury.

Personal injury or equipment damage caused by sudden release of pressure may result if the CVX valve is installed where service conditions could exceed the limits of the pressure rating noted on the nameplate. To avoid such injury or damage, provide a relief valve for over pressure protection as required by government or accepted industry codes and good engineering practices.

Check with your process or safety engineer for any additional measures that must be taken to protect against process media.

If installing into an existing application, also refer to the WARNING at the beginning of the Maintenance section in this instruction manual.

CAUTION

This valve is intended for a specific range of service conditions (see table 1). Applying different conditions to the valve could result in parts damage, malfunction of the valve, or loss of control of the process. *Do not expose this valve to service conditions or variables other than those for which this valve is intended.* If you are not sure what these conditions are, you should contact Emerson Automation Solutions for more complete specifications. Provide the product serial number (shown on the nameplate) and all other pertinent information.

Check that the CVX valve is properly orientated with respect to the flow direction of the valve (flow down). Incorrect installation can result in damage to the valve and poor performance.

1. Before installation, all piping upstream of the valve must be blown clean so that no loose materials such as welding slag, dirt or other foreign matter, are left in the pipe. Use care to keep foreign matter out of the line openings while preparing the valve installation.
2. If possible, before fitting in the line, connect the actuator to a temporary air supply and operate to verify positioning. Disconnect the instrument lines (if applicable).

⚠ WARNING

Do not lift the valve by its actuator yoke or cooler manifold piping. Lifting lugs attached to the actuator must not be used to lift the complete valve assembly unless clearly marked as being rated to support the complete valve assembly weight. Personal injury or damage to equipment could occur if the valve is improperly lifted into place.

All lifting and rigging must be completed in accordance with federal/national/provincial, state and local regulations and applicable lifting and rigging equipment standards. Only personnel trained in proper lifting and rigging practices shall perform valve/actuator assembly lifting, rigging and installation. Because each lift will be unique, the method of lifting the valve assembly, the correct location for attaching and lifting the valve assembly, and what the valve assembly will do when lifted shall be considered for each lift.

Lifting and rigging equipment used to lift, install or remove a valve assembly or component must be properly selected and sized for the weight and configuration of the valve assembly or component being lifted. The weight of the complete valve assembly, including attached accessories, must be taken in consideration for this purpose. The lifting and rigging equipment must be properly maintained and inspected for damage before each use.

Lifting lugs or other lifting equipment attached to the valve or actuator must never be used to lift or support the weight of attached piping.

If the CVX is equipped with butt weld ends, the valve body must be supported using a lifting sling or other method that does not place a load or force onto the finished surface of the butt weld ends. The CVX does not have a stable resting position. The valve inlet and outlet must be fully supported until fully welded (butt weld end connections) or bolted (flanged end connections) into the piping.

CAUTION

Care must be taken when lifting the valve/actuator assembly to ensure all accessories and tubing are not damaged in the process. Accessories and tubing may need to be removed prior to lifting to prevent damage and properly reinstalled before use. Protect valve flange faces, butt weld ends, and other connection surfaces from damage during lifting.

3. Arrange lifting slings, or other lifting and rigging equipment appropriate for the valve weight and configuration around the main valve body to safely lift the valve to the pipe opening.

⚠ WARNING

Do not expose the valve to undue stresses by installing it in bent pipes or flanges. Personal injury and equipment damage could result from flange sealing failure due to improper installation.

4. Flanged Connections—Lubricate the flange connection bolts with a high temperature thread lubricant. Install flange gaskets and connection bolts per accepted practices and tighten securely.
5. Welded Connections—Welding procedures should be in accordance with the applicable codes and the base materials. For preheat, welding electrodes, and postweld heat treatment, refer to the applicable codes and practices applicable for the specific facility. Materials are specified on the customer specification sheet. Emerson Automation Solutions recommends the valve be disassembled for welding, however if the valve inlet and outlet connections are to be welded with the valve assembled, the valve plug should be maintained off the valve seat during all associated operations. If the valve is to be welded by SMAW process, the valve must be disassembled for welding to ensure that any weld slag is removed from the valve.

CAUTION

Depending on valve body materials used, post weld heat treating may be required. If so, damage to internal parts is possible. In general, if post weld heat treating is to be performed, all trim parts and nozzles should be removed. Contact your Emerson Automation Solutions sales office for additional information.

6. Remove the spraywater control valve and flush the cooling water line until all debris is removed from the line prior to connecting it to the CVX valve. Use only clean sources of cooling water to reduce the possibility of nozzle clogging. A strainer should be installed in the water line as close to the CVX valve as possible. To determine appropriate mesh size, refer to valve sizing and specification document, or contact your [Emerson sales office](#). Review strainer manufacturer's pressure drop curves to determine appropriate strainer body size. You may need to use a strainer that is larger than the water line size.

⚠ WARNING

Failure to use a strainer could result in nozzle clogging and subsequent property damage or loss. Uncontrolled temperatures resulting from clogged nozzles may result in equipment or process temperature limits being exceeded. Exceeding system temperature limits could result in property damage or personal injury.

7. A length of straight pipe is required downstream of the CVX valve to ensure complete vaporization of cooling water. An example of a typical installation appears in figure 2. Consult the CVX cooler sizing sheet for the required distance of straight pipe. This is unique for each application and is supplied by Emerson.

8. Typically, a temperature sensor should be mounted downstream of the CVX valve. This distance will vary depending on a number of factors including steam velocity and percentage of spraywater. Consult the cooler sizing sheet provided with the unit for this temperature sensor distance. The steam line should not have any branch lines dividing the steam flow between the CVX valve and the temperature sensor. If you have any questions, contact your Emerson sales office.
9. A typical installation is illustrated in figure 2. A pressure transmitter senses the pressure downstream (or upstream in backpressure control applications). The pressure controller sends a signal to the actuator positioner opening or closing the CVX valve as required to maintain pressure. A rising stem opens the CVX valve to allow additional steam flow. A temperature sensor (TE) measures changes in temperature and a temperature transmitter (TT) transmits the signal to the temperature control device. The output signal from the controller is sent to the positioner on the cooling water (spraywater) control valve (SWCV). The positioner's output signal strokes the SWCV open, increasing water pressure on the nozzles. Increasing water pressure upstream of the nozzles increases water flow through the nozzles.

CAUTION

Pneumatic lines (where applicable) should be thoroughly blown clean with dry air before connection. Check to make sure wiring connections are made per the equipment manufacturer's instructions and in accordance with local, regional, and national codes.

10. If foreign debris has been introduced into the valve or upstream piping during installation, it must be removed prior to using the valve for the first time. A Blowout or Blow-through tool can be purchased to match the CVX valve and facilitate piping blowdown without removal of the valve from the line. Contact your Emerson sales office for pricing and availability of fixtures.
11. After cleanliness of the piping system has been assured, connect instrumentation and power supply to the CVX valve actuator and associated equipment.
12. Monitor the CVX valve as the system is brought on line. Some visible vapors may be seen as the lubricants are heated. If you see any steam leaks after startup, follow isolation and disassembly procedures and disassemble the valve and replace the gaskets (key 43). If the packing box leaks, tighten hex nuts (key 68). If leakage continues, replace the packing (key 64). Be sure to properly isolate the CVX valve prior to disassembly of valve or packing.

⚠ WARNING

Personal injury could result from packing leakage. Valve packing was tightened prior to shipment; however, the packing might require some readjustment to meet specific service conditions. Check with your process or safety engineer for any additional measures that must be taken to protect against process media.

Maintenance

It is recommended that diagnostic tests be performed on the valve 3-6 months prior to scheduled maintenance shutdowns. Complete valve disassembly is recommended if tests performed on the valve indicate leakage, sticking or substandard operation. If diagnostics indicate normal valve operation, complete disassembly and inspection of the CVX is recommended during every other regularly scheduled outage or after 24-36 months, whichever comes first. Table 2 identifies the recommended inspection tips and diagnostics that can be performed with corresponding repair and replacement information.

⚠ WARNING

Avoid personal injury or property damage from sudden release of process pressure or bursting of parts. Before performing any maintenance operations:

- Do not remove the actuator from the valve while the valve is still pressurized.
 - Always wear protective gloves, clothing, and eyewear when performing any maintenance operations to avoid personal injury.
 - Disconnect any operating lines providing air pressure, electric power, or a control signal to the actuator. Be sure the actuator cannot suddenly open or close the valve.
 - Use bypass valves or completely shut off the process to isolate the valve from process pressure. Relieve process pressure from both sides of the valve. Drain the process media from both sides of the valve.
 - Vent the power actuator loading pressure and relieve any actuator spring precompression.
 - Use lock-out procedures to be sure that the above measures stay in effect while you work on the equipment.
 - The valve packing box may contain process fluids that are pressurized, *even when the valve has been removed from the pipeline*. Process fluids may spray out under pressure when removing the packing hardware or packing rings, or when loosening the packing box pipe plug.
 - Check with your process or safety engineer for any additional measures that must be taken to protect against process media.
-

Table 2. Inspection Summary

Key	Part Description	Inspection Tips and Diagnostics	Repair	Replacement
1	Valve Body	Inspect for erosion, thermal fatigue, and other damage.	Consult your local Emerson Service Center for a recommendation on necessary weld repair or replacement if damage exists.	
6	Bonnet	Inspect gasket surfaces for damage that could indicate gasket leakage. Inspect packing box to ensure no galling, scoring, or particulate is present.	If damage exists consult your local Emerson Service Center for a recommendation on necessary weld repair or replacement.	
20	Nozzle Body Flange	Inspect gasket surfaces for damage that could indicate gasket leakage when spray nozzles are replaced.	Replacement Only	As needed
21	Cage	Inspect cage bore for excessive wear, galling damage, particulate damage, and flow passage damage or clogging.	Consult your local Emerson Service Center for a recommendation on necessary repair or replacement if damage exists.	As needed for optimal performance
22	Plug	Inspect for seat erosion, excessive wear, galling damage, and particulate damage, paying close attention to the seating and guiding surfaces.	Re-cutting/machining of seating surfaces can be performed by your local Emerson Service Center.	As needed for optimal performance
23, 53	Stem and Stem Pin	Inspect stem for dings, scoring, and galling. Inspect valve stem connection for tightness.	Valve stem connection can be repaired by your local Emerson Service Center.	As needed
24	Seat	Inspect for seat erosion, particulate damage, galling, and proper bolt torque (if applicable, refer to table 5).	Re-cutting/machining of seating surfaces can be performed by your local Emerson Service Center.	As needed to maintain proper shutoff
25	Plug Retainer	Inspect for excessive wear, galling, and other damage.	Repair can be performed by your local Emerson Service Center.	As needed
30	Spray Nozzle	Refer to Nozzle Maintenance Section.		Replacement every 24-36 months for optimal performance
37	Nozzle Sleeve	Inspect for particulate or magnetite buildup when spray nozzles are replaced.	Clean if necessary	As needed
43, 47, 48, 75	All Gaskets	Every valve disassembly requires replacement of gaskets.	Replacement Only	Every valve disassembly
45	Piston Ring	Inspect for particulate buildup, scoring, and excessive wear. Ensure piston ring is free to expand and contract in the groove.	Replacement Only	As needed
46	Bore Seal Ring	Inspect for excessive wear, galling, signs of leakage, and other damage.	Replacement Only	Every 36 months for optimal performance
63	Packing Box Ring	Inspect for scoring, galling, and other damage.	Replacement Only	As needed
64	Packing Set	Every valve disassembly requires replacement of the packing set.	Replacement Only	Every valve disassembly
65	Packing Follower	Inspect for scoring, galling, and other damage.	Replacement Only	As needed
66	Packing Flange	Inspect for scoring, galling, and other damage.	Replacement Only	As needed
77	Bolted Diffuser	Inspect for thermal fatigue, erosion, particulate damage, and flow passage damage or clogging.	Clean if necessary	As needed
N/A	Welded Diffuser	Inspect for thermal fatigue, erosion, particulate damage, and flow passage damage or clogging.	Clean if necessary	Consult your local Emerson Service Center if replacement is necessary.

Servicing

Shut off water and steam flow and vent all system pressure before breaking any pressure boundaries.

⚠ WARNING

Residual system pressure may be released during the following steps if the system was improperly isolated or vented. Use extreme care to prevent personal injury while loosening any fasteners in the pressure boundary.

Removal of Valve Bonnet and Trim

1. Disconnect all external connections to the positioner and actuator and remove the actuator from the valve. Consult the actuator manufacturer's documentation for assistance in actuator removal.
2. Loosen and remove the hex nuts (key 68) along with the packing follower (key 65). If possible, remove packing set (key 64) from the packing box.
3. Loosen bonnet stud nuts (key 55) using an even pattern to avoid uneven expansion of the gaskets. Remove the entire bonnet assembly (key 6), pulling evenly in line with the valve stem (key 23) centerline. Uneven bonnet removal can result in galling or bending of the valve stem. If difficulty is encountered in removing the bonnet, check the bonnet for alignment and straighten the bonnet before making further attempts to remove it from the valve body.

CAUTION

The bonnet must be handled with care while being removed from the body. Damage to the bonnet can result in gasket leakage while the valve is in service.

Protect the bonnet by placing it on clean cloth or wood while the valve is disassembled.

4. Dislodge any remaining packing (key 64) from the packing box and discard. Remove the packing box ring (key 63) from the bottom of the packing box. Inspect all parts: packing box, packing box ring (key 63), packing follower (key 65), valve stem (key 23), hex nuts (key 68) and studs (key 69) for signs of wear. Replace parts that are damaged or show excessive wear.
5. Inspect the bonnet guiding surfaces and gasket mating surfaces. Light damage on the guiding surface may be repaired with an emery cloth or other suitable material. Damage to the gasket mating surface may require bonnet replacement to avoid leakage.
6. Remove the plug assembly (keys 22, 23, and 53) as a single unit by lifting the valve stem (key 23) with appropriate rigging and lifting equipment and pulling the assembly from the body cavity. The plug assembly contains sensitive guiding and sealing surfaces on its outside diameter and care must be taken in its handling. Protect the plug by placing it on clean cloth or wood while the valve is disassembled.
7. Remove the cage (key 21) from the valve body. Remove and discard cage gaskets (key 43 and 44). Reference figures 9, 10, 11, 12, and 13 for guidance in performing this disassembly. The cage contains sensitive guiding surfaces on its inside and outside diameter and care must be taken during handling. Protect the cage by placing it on clean cloth or wood while the valve is disassembled.
8. ANSI/FCI 70-2 Class V constructions only: Clean and inspect the guiding and sealing surfaces of the plug assembly. Inspect the piston ring (key 45) and Bore Seal ring (key 46) for signs of excess wear or damage and replace if necessary. The piston ring is a two-piece design with an outer seal ring and an inner expander ring. The outer ring diameter should be expanded beyond the diameter of the plug in its free state. It can be shifted within its groove to

inspect for uneven wear around its circumference. The piston ring should require some compression when installing the plug into the cage. Lack of required compression indicates that the piston ring has worn or relaxed and should be replaced. Vertical marks in the axial orientation also indicate wear that requires replacement of the ring. The Bore Seal ring has a C-shaped cross section with the open portion of the C-shape facing the seat ring side of the plug. Any uneven marks around the circumference of the ring or any flattening of the ring shape at its outside diameter are indications of wear and require replacement. Contact your [Emerson sales office](#) for Bore Seal ring replacement.

ANSI/FCI 70-2 Class IV constructions only: Clean and inspect the guiding and sealing surfaces of the plug assembly. Inspect the two piston rings (key 45) for signs of excess wear or damage and replace if necessary. The piston ring is a two piece design with an outer seal ring and an inner expander ring. The outer ring diameter should be expanded beyond the diameter of the plug in its free state. It can be shifted within its groove to inspect for uneven wear around its circumference. The piston ring should require some compression when installing the plug into the cage. Lack of required compression indicates that the piston ring has worn or relaxed and should be replaced. Vertical marks in the axial orientation also indicate wear that requires replacement of the ring.

9. Clean and inspect the cage bore for excessive wear. The entire length of the cage bore is either a sealing and/or guiding surface and any measurable wear requires that the cage be replaced.
10. Welded seat rings remain retained inside the valve body. Clean and inspect the seating surface. Any detectable damage around the circumference of the seating surface is an indication of wear and requires reconditioning to ensure seating performance. Contact your Emerson sales office for specific instructions on reconditioning the seating surface. If the CVX has a bolted seat ring, remove the cap screws (key 76) and discard the gasket (key 75) that sits between the seat ring and diffuser (key 77) or valve body, depending on construction. Inspect cap screws for damage and excessive wear; replace as necessary.
11. **Removable (bolted/camped) diffuser constructions only.** Remove the diffuser (key 77 or 24) and gasket (key 75) that sits between the diffuser and valve body. Inspect the diffuser for thermal fatigue and flow passage damage or clogging and clean if necessary. Diffuser replacement will be necessary if damage is present. The bolted diffuser contains sensitive guiding surfaces on its outside diameter and care must be taken during handling. Protect the seat diffuser by placing it on a clean cloth or wood while the valve is disassembled.
12. **Welded diffuser constructions only.** Inspect the diffuser for thermal fatigue and flow passage damage or clogging and clean if necessary. If damage or clogging remains after cleaning, then diffuser replacement will be required; contact your local Emerson Service Center for this process.
13. Remove all used gaskets and foreign material from the interior of the valve and from the inlet and outlet openings. Remove any foreign material that may be in the valve body or trim. Inspect all valve body guiding and sealing surfaces for any signs of wear.
14. If the valve has been in service, visually inspect the interior of the valve for abnormal wear, erosion, or thermal fatigue. The gasket surfaces of the valve body and bonnet should be inspected to verify they are not damaged and are free of imbedded gasket material. All scratches should be removed by grinding or filing to remove any interference of the clearance zones between the internal bores and the mating parts. All signs of thermal fatigue should be carefully evaluated to determine if repair or replacement is necessary. Your local Emerson Service Center can help determine the severity of damage, if present, and recommend a course of action.

Figure 3. Fisher AF Nozzle Cross Section

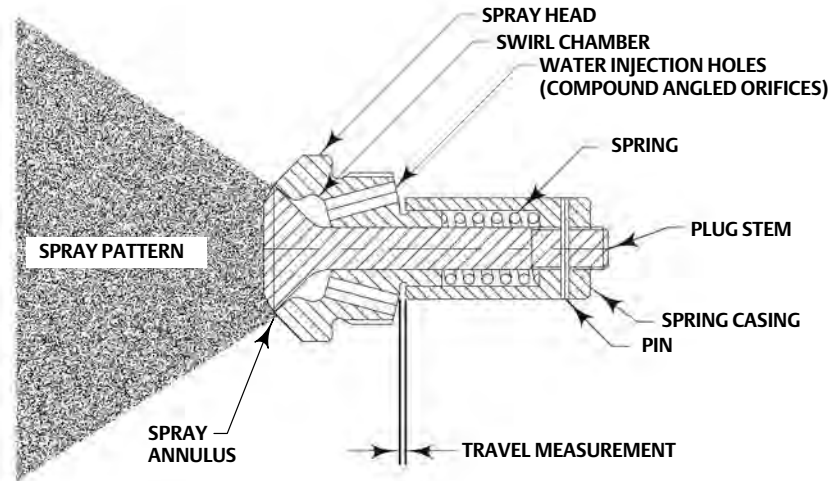

A7191-2D

Nozzle Maintenance and Replacement

When subjected to normal operating conditions, it is possible that wear, blockage, and/or weld fatigue will occur to the valve body or nozzle assembly. During regularly scheduled maintenance, visually inspect the nozzles for wear and blockage. Your local Emerson Service Center can help to determine the extent of weld fatigue and the correct course of action. Poor performing nozzles or nozzle failure is typically caused by wear, corrosion, erosion, and/or blockage. The following instruction will help to determine if any of these problems are present and provide a recommended course of action for each.

Note

For optimal performance, nozzles should be inspected every 18 to 24 months and replaced every 24 to 36 months.

1. **OPTIONAL:** Figure 3 shows the spray pattern that will need to be present during operation of the AF nozzles. Testing can be performed by attaching the existing or an alternate, similar pressure, water line to the spray water input connection. If this spray pattern is not present, replacement is recommended.
2. Loosen and remove the nozzle body flange stud nuts (key 58) and washers (key 59). Then, remove the nozzle body flange (key 20). Inspect the nozzle body flange gasket surfaces for damage. If damage is present replacement is necessary.
3. Remove the nozzle sleeve (key 37) with attached spray nozzle (key 30), nozzle sleeve gasket (key 47), and nozzle body flange gasket (key 48). Inspect the nozzle sleeve for particulate or magnetite buildup and clean if necessary.
4. Inspect the spray annulus surface, the area between the plug stem and spray head, for excessive wear, erosion/corrosion, or blockage due to particulate. Wear is defined as any nicks, cuts, or gouges on or immediately around the spray annulus. Erosion/corrosion is defined as any form of rust or erosion of the metal on the plug stem or spray head. Blockages are typically caused by small particulate trapped between the plug stem and spray head or spring casing and spray head. Replacement of the nozzle is recommended if any of the preceding problems are present.

5. Grind off the tack welds holding the nozzle (key 30) in place. Apply a penetrant type thread lubricant and allow to soak prior to unscrewing the nozzle. Using the provided flats on the side of the spray head, unscrew the nozzle from the nozzle sleeve (key 37).
6. Grind excess tack weld material off both the nozzle (key 30) and nozzle sleeve (key 37).
7. In the absence of external forces, the nozzle must be fully closed. If the nozzle is not fully closed, it will need to be replaced.
8. Inspect the water injection holes for reduced or non-circular shape due to erosion. Every hole must be the same size and shape. If any are over-sized or non-circular in shape, the nozzle will need to be replaced.
9. Inspect the interior of the water injection holes for buildup of particulate or magnetite. Nozzle replacement will be needed if any buildup is present.

Note

Complete disassembly of the nozzle is strongly discouraged, due to individual spare parts not being available.

10. **OPTIONAL:** To further check the nozzle for buildup of particulate or magnetite, the nozzle can be disassembled. If disassembled, take great care not to damage the sharp edges of the spray annulus on the plug stem and the sprayhead, as this will greatly affect the spray pattern. Do not compress a removed spring by hand or with a tool, as compression beyond its normal operating range will damage the spring.

To disassemble the nozzle, first remove the pin using a small punch, and unscrew the spring casing from the plug stem. The nozzle can be reassembled by following a reverse order of disassembly, taking care to line the hole in the plug stem up with the hole in the spring casing, then pressing the pin back into place through the two parts.

11. The internal spring may relax over time and not provide the tensile force required to shut off and control flow. If the nozzle spring is suspected of being too relaxed, then the nozzle should be replaced.
12. The travel can be determined by using a feeler gauge to measure the distance between the spray head near the water injection ports to the side of the spring casing, as outlined in figure 3. This measurement must match the factory set plug stem travel for the corresponding nozzle type as shown in table 3.

Table 3. AF Nozzle Specifications

NOZZLE TYPE	PLUG TRAVEL, INCHES
AF7	0.014
AF10	0.028
AF14	0.029
AF17	0.034
AF20	0.036
AF24	0.042
AF28	0.048
AF32	0.056
AF35	0.065
AF40	0.063
AF44	0.069

13. Inspect nozzle threads for damage and clean if needed. If damage is present, nozzle replacement will be necessary.
14. Rinse both the nozzle (key 30) and nozzle sleeve (key 37) to remove particulate.
15. Screw nozzle into the nozzle sleeve (key 37) and tighten just until the spray head is flat and tight against the nozzle sleeve.
16. Tack-weld a small piece of welding wire onto the nozzle sleeve (key 37) next to either of the spray head flats to prevent rotation during service; refer to figure 4. Maintain low heat to prevent distortion of the nozzle.

Figure 4. Spray Nozzle Tack Weld Location

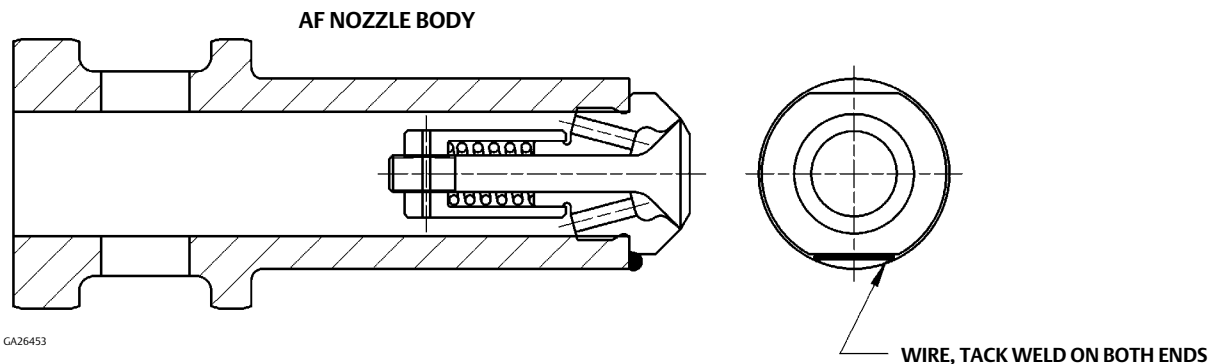

17. Reassemble in the following order: nozzle sleeve gasket (key 47), nozzle body flange gasket (key 48), spray nozzle/sleeve assembly (key 30 and 37), nozzle body flange (key 20), washers (key 59), and stud nuts (key 58). It is required to replace the nozzle sleeve gasket (key 47) and nozzle body flange gasket (key 48) with new gaskets each time the nozzle body flange (key 20) is removed.

Note

Stud(s) and nut(s) should be installed such that the manufacturer's trademark and material grade marking is visible, allowing easy comparison to the materials selected and documented in the Emerson/Fisher serial card provided with this product.

⚠ WARNING

Personal injury or damage to equipment could occur if improper stud and nut materials or parts are used. Do not operate or assemble this product with stud(s) and nut(s) that are not approved by Emerson/Fisher engineering and/or listed on the serial card provided with this product. Use of unapproved materials and parts could lead to stresses exceeding the design or code limits intended for this particular service. Install studs with the material grade and manufacturer's identification mark visible. Contact your Emerson representative immediately if a discrepancy between actual parts and approved parts is suspected.

18. Lubricate the nozzle body studs (key 57) and all surfaces the studs and nuts come into contact with. Tighten the nozzle body flange nuts (key 58) in a uniform, multistage cross pattern. You may need to torque multiple times at each torque to ensure that the nozzle body flange is torqued evenly. Required nozzle body flange bolting torque can be found in table 4.

Table 4. Recommended Nozzle Body Flange Bolting Torque with Nickel Anti-Seize Lubricant⁽¹⁾

BOLT SIZE Inch	THREADS PER INCH	LUBRICATION	RECOMMENDED BOLT TORQUE ⁽²⁾	
			N•m	Lbf•ft
5/8	11	Nickel Anti-Seize	163	120
3/4	10		258	190
7/8	9		373	275
1	8		522	385
1-1/8	8		712	525
1-1/4	8		942	695
1-3/8	8		1268	935
1-1/2	8		1654	1220

1. For other lubricants, contact your [Emerson sales office](#) for recommended bolt torque.
 2. Torques for lubricated studs with heavy hex nuts.

Valve Assembly

1. Cleaning--Make certain that all interior surfaces of the valve body and bonnet (including the packing box) are clean and free of dirt, including the inlet and outlet openings. All surfaces of the valve interior that receive mating parts should be given special attention when cleaning. All sliding fit surfaces should be coated with a copper-based high temperature anti-seize lubricant prior to reassembly. Refer to figures 9, 10, and 11 for reference.

If the CVX has a removable seat ring, proceed with steps 2 through 4; otherwise proceed directly to step 5.

2. Place one gasket (key 75) into the valve body. If the CVX has a welded-in diffuser: Install the seat ring (key 24) onto this gasket surface. If the CVX has a removable diffuser: install the diffuser (key 77 or 24) onto this gasket surface. If trim is bolted, ensure the bolt holes in the diffuser are positioned with the bolt holes in the valve body. Then place another gasket (key 75) onto the diameter of the diffuser, and install the seat ring onto this second gasket surface. Clamped trim constructions will only have one gasket (key 75). Proceed to step 6 if using clamped trim.

Note

Horizontal actuator only: CVX valves positioned in the process pipeline with a horizontal actuator/trim may require special attention to ensure that the spiral wound gaskets are maintained in the proper location during the valve assembly procedures without falling out of the gasket groove. A gasket manufacturer recommends spray adhesive 3M #77 Super Spray Adhesive to temporarily hold gaskets in place until they are fully contained by the CVX valve body and trim components. Please note special spiral wound gasket-positioning techniques may be recommended. To use the adhesive, lightly spray the gasket groove that the gasket will be installed in. Also lightly spray one side of the spiral wound gasket that will be contacting the previously coated gasket groove. Let the spray adhesive set for one minute and then lightly press the spiral wound gasket into the gasket groove.

Other Considerations: Ensure the spiral wound gasket is located in the correct location when contact is made. Trying to remove the gasket after contact will damage the gasket by pulling out or removing the soft filler/facing material. If the gasket is incorrectly positioned after applying the spray adhesive it must be removed and discarded. The gasket groove will then need to be cleaned and a new gasket will need to be installed.

3. Lubricate the seat ring cap screws (key 76) and all surfaces that contact the screws, including the valve body and seat ring.
4. Torque the cap screws in a crisscross pattern, using no more than 1/4 of the specified torque as indicated in table 5. Repeat the crisscross pattern, working up to the specified torque in 1/4 increments until the final torque is achieved. Wait a minimum of one minute to allow for gasket/screw relaxation and recheck the torque, adjusting as necessary.

Table 5. CVX (Flow Up and Flow Down) Bolted Seat Ring Torque with Nickel Anti-Seize Lubricant⁽¹⁾

CAP SCREW SIZE Inch	THREADS PER INCH	LUBRICATION	RECOMMENDED BOLT TORQUE	
			N • m	lbf • ft
3/8	16	Nickel Anti-Seize	41	30
1/2	13		91	67
5/8	11		163	120

1. For other lubricants, contact your [Emerson sales office](#) for recommended bolt torque.

Note

Stud(s) and nut(s) should be installed such that the manufacturer's trademark and material grade marking is visible, allowing easy comparison to the materials selected and documented in the Emerson/Fisher serial card provided with this product.

⚠ WARNING

Personal injury or damage to equipment could occur if improper stud and nut materials or parts are used. Do not operate or assemble this product with stud(s) and nut(s) that are not approved by Emerson/Fisher engineering and/or listed on the serial card provided with this product. Use of unapproved materials and parts could lead to stresses exceeding the design or code limits intended for this particular service. Install studs with the material grade and manufacturer's identification mark visible. Contact your Emerson Automation Solutions representative immediately if a discrepancy between actual parts and approved parts is suspected.

5. Install one cage gasket (key 43) into the groove in the valve body. If the valve has a horizontal stem orientation, ensure the gasket remains in the groove and does not get pinched during cage installation.

Note

Horizontal actuator only: Follow the note in Step 2 above to ensure the gasket are in the proper location during valve assembly.

6. Lubricate the inside of the cage as completely as possible. Insert the lubricated cage (key 21) into the valve body. Ensure the lower cage diameter slides over the outside diameter of the seat ring. If there is any question regarding the proper seating of the cage inside the valve body, the following measurements can be taken for confirmation. For welded or bolted seat rings: Measure the thickness of the cage flange at its largest diameter. Measure the depth of the mating counterbore where the cage flange engages into the valve body. When assembled with a new cage gasket, the resulting depth from the top of the valve body to the top of the cage flange should be the difference in these two measured valves, minus an additional 0.045 to allow for the uncompressed gasket.

If the CVX is an ANSI/FCI 70-2 Class V construction, proceed with steps 7-12; otherwise proceed directly to step 13 for Class IV constructions.

7. The plug assembly includes a plug (key 22), stem (key 23), stem pin (key 53), retainer (key 25), piston ring (key 45) and Bore Seal ring (key 46). Lubricate the plug assembly at all raised outside diameter surfaces and lubricate the piston ring and Bore Seal ring.
8. Orient the Bore Seal for correct sealing action according to figure 5.

Figure 5. Fisher Bore Seal Construction

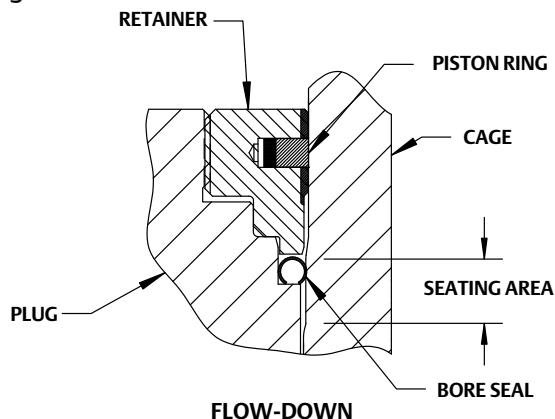

9. Place the Bore Seal plug seal over the top of the valve plug. The retainer will help guide the Bore Seal down onto the plug. Do not force the Bore Seal over the plug (figure 6).
10. Apply a suitable high-temperature lubricant to the threads on the plug. Then, place the Bore Seal retainer onto the plug and tighten the retainer using an appropriate tool such as a strap wrench.
11. Using an appropriate tool such as a center punch, stake the threads on top of the plug in one place to secure the Bore Seal retainer.
12. Install the lubricated plug assembly into the cage. The piston ring should require some radial compression to collapse into the cage diameter. Do not use a metallic tool to create this piston ring compression as this could damage the outer sealing diameter of the ring. The plug should slide into the cage smoothly with little effort until the Bore Seal ring reaches its mating cage diameter. The extra load required to seat the Bore Seal trim seal will be applied during actuator set up.
13. ANSI/FCI 70-2 Class IV constructions only: The plug assembly includes a plug (key 22), stem (key 23), and two piston rings (key 45). Lubricate the plug assembly at all raised outside diameter surfaces and lubricate the piston rings. Install the lubricated plug assembly into the cage. The piston ring should require some radial compression to collapse into the cage diameter. Do not use a metallic tool to create this piston ring compression, as this could damage the outer sealing diameter of the ring. The plug should slide into the cage smoothly with little effort. Refer to figure 7.

Figure 6. Retainer Guiding Fisher Bore Seal Onto the Plug

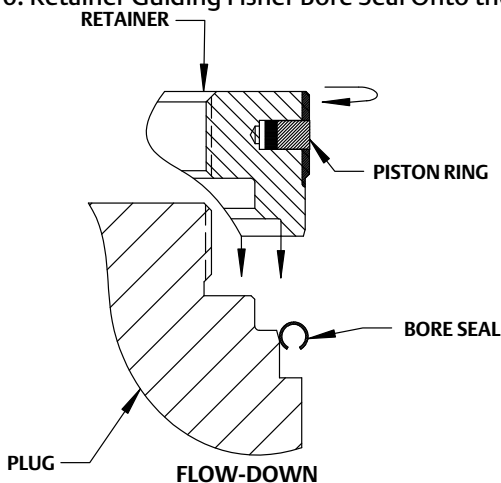

14. Install the second cage gasket (key 43) over the cage boss where it will be self-centering for the mating bonnet groove. For clamped trims, install the bonnet gasket (key 44) in the body groove.

Note

Stud(s) and nut(s) should be installed such that the manufacturer's trademark and material grade marking is visible, allowing easy comparison to the materials selected and documented in the Emerson/Fisher serial card provided with this product.

⚠ WARNING

Personal injury or damage to equipment could occur if improper stud and nut materials or parts are used. Do not operate or assemble this product with stud(s) and nut(s) that are not approved by Emerson/Fisher engineering and/or listed on the serial card provided with this product. Use of unapproved materials and parts could lead to stresses exceeding the design or code limits intended for this particular service. Install studs with the material grade and manufacturer's identification mark visible. Contact your Emerson representative immediately if a discrepancy between actual parts and approved parts is suspected.

15. Apply appropriate high-temperature anti-seize lubricant to the bonnet studs (key 54) and screw them into the valve body. Back the studs out 1/2 to 1 turns after bottoming the stud in the valve body.
16. Lubricate the bonnet locating surfaces and carefully install the bonnet (key 6). Use care to avoid bending the stem.
17. Install bonnet stud washers (key 52) and nuts (key 55) and hand tighten.
18. Tighten the bonnet nuts (key 55) in a uniform, multistage cross pattern. Monitor the distance between the bonnet and body and keep it even to ensure that the bonnet is being torqued evenly. It is recommended that torquing be performed in a minimum of four torque levels until the final torque level is achieved. You may need to torque multiple times at each torque level to ensure that the bonnet is torqued evenly. Required torque can be found in table 6. After final torquing, ensure there is an even gap and that the metal-to-metal contact between the valve body and bonnet is achieved around the entire circumference of the body-bonnet joint.

Table 6. Recommended Body/Bonnet Bolting Torque with Nickel Anti-Seize Lubricant⁽¹⁾

BOLT SIZE Inch	THREADS PER INCH	LUBRICATION	RECOMMENDED BOLT TORQUE ⁽²⁾	
			N•m	Lbf•ft
1	8	Nickel Anti-Seize	522	385
1-1/8	8		712	525
1-1/4	8		942	695
1-3/8	8		1268	935
1-1/2	8		1654	1220
1-5/8	8		2129	1570
1-3/4	8		2671	1970
1-7/8	8		3308	2440
2	8		4027	2970
2-1/4	8		5776	4260

1. For other lubricants, contact your [Emerson sales office](#) for recommended bolt torque.
2. Torques for lubricated studs with heavy hex nuts.

19. After the bonnet has been torqued to the required level, check the plug movement to ensure that the plug still moves freely.
20. Recheck cleanliness of the packing box. Insert the packing box ring (key 63) over the stem and into the packing box. Measure the depth of the packing box before and after ring insertion to be certain that it has traveled to the bottom of the packing box. Insert packing rings (key 64), after lubricating with high temperature grease, into the packing box and staggering the gaps on adjacent rings. The packing follower (key 65) can be used to ensure that each packing ring is pushed down before installing the next packing ring.
21. After all packing rings are installed, thoroughly lubricate the studs (key 69) and insert the packing follower (key 65) and the packing flange (key 66). Tighten the hex nuts (key 68) tight enough to block leakage but not so tight that stem travel is hindered. Consult table 7, Recommended Packing Nut Torque for recommended torque levels. Evenly tighten the nuts to the maximum level, then loosen and retighten to the minimum torque level. After operating, further tightening may be required to prevent leakage.
22. Install the actuator on the valve in accordance with manufacturer's standard procedure. If this is an ANSI/FCI 70-2 Class V construction, the plug assembly will require an additional load and travel to seat the Bore Seal ring (refer to figure 8 for details). After calibration of the actuator, the valve should be ready to return to service.

Table 7. Recommended Packing Nut Torque with Anti-Seize Lubricant

STEM DIAMETER Inch	ASME PRESSURE RATING	MAXIMUM TORQUE		MINIMUM TORQUE	
		N•m	Lbf•ft	N•m	Lbf•ft
1-1/4	CL300	49	36	33	24
	CL600	67	49	45	33
	CL900	83	61	56	41
	CL1500	102	75	68	50
	CL2500	122	90	82	60
2	CL300	65	48	59	43
	CL600	91	67	83	61
	CL900	120	88	109	80
	CL1500	147	108	133	98
	CL2500	170	125	156	115

Figure 7. Fisher CVX Class IV Construction

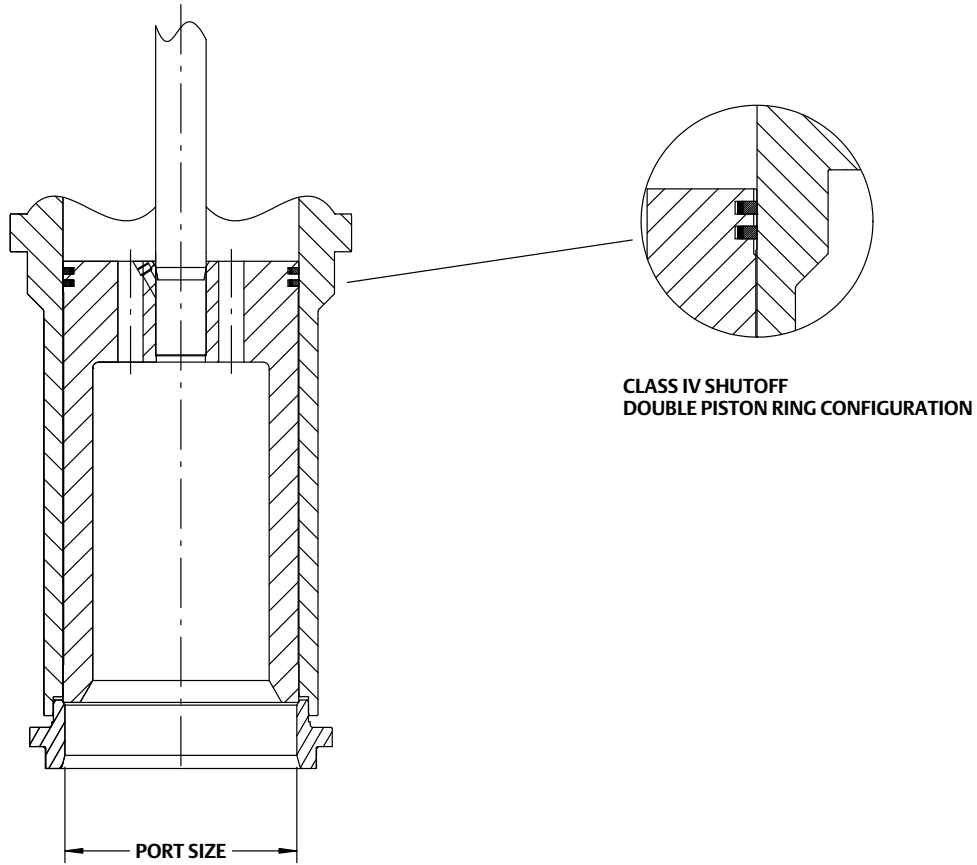
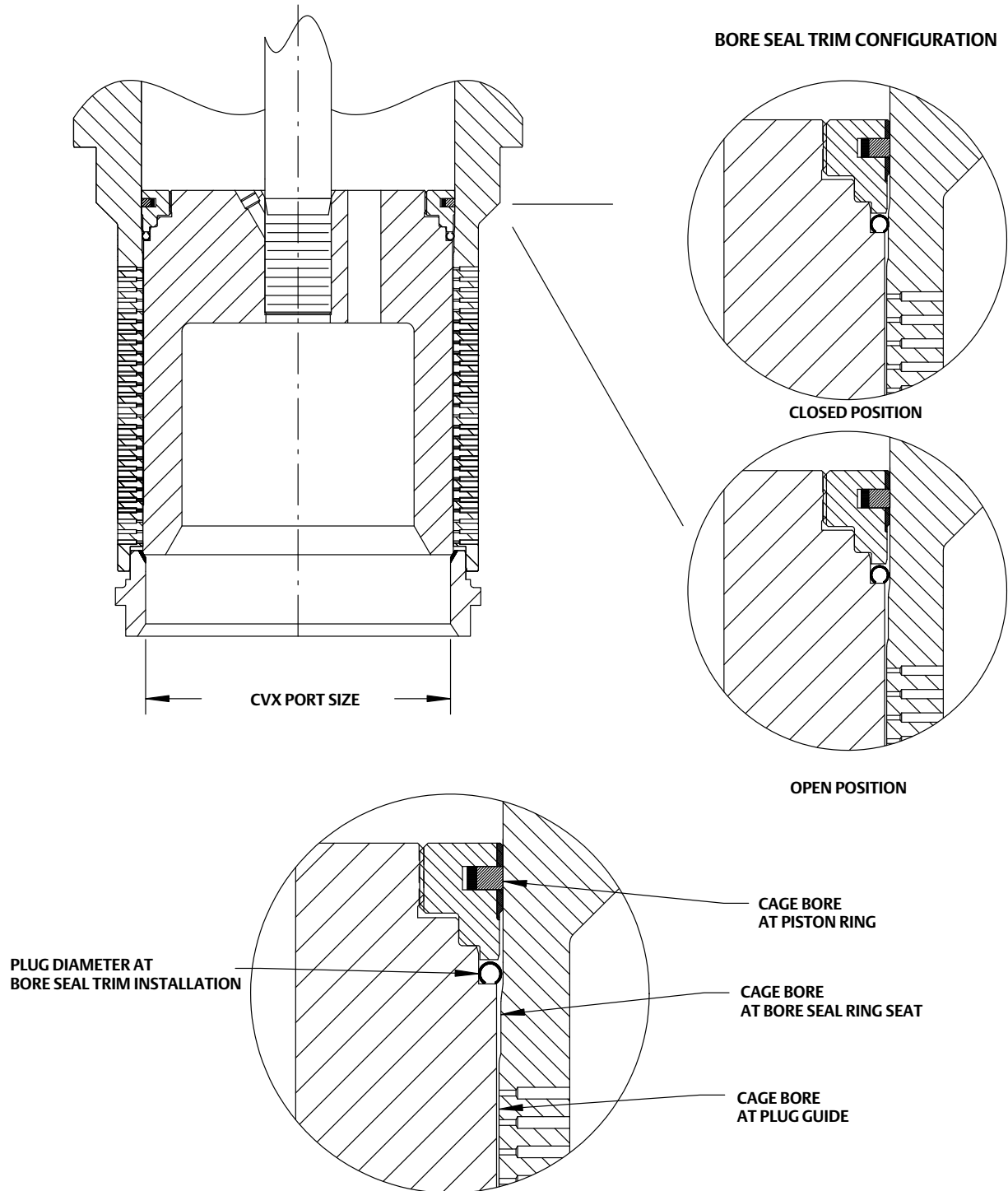

Figure 8. Fisher CVX Class V Construction



Parts Ordering

Each CVX valve is assigned a serial number that can be found on the bonnet flange. Refer to the serial number when contacting your [Emerson sales office](#) for technical assistance. When ordering replacement parts, refer to the serial number and key numbers for each part required. The key numbers in the Parts List and the assembly drawing in figures 9, 10, and 11 can be used to help in part identification.

⚠ WARNING

Use only genuine Fisher replacement parts. Components that are not supplied by Emerson Automation Solutions should not, under any circumstances, be used in any Fisher valve, because they may void your warranty, might adversely affect the performance of the valve, and could cause personal injury and property damage.

Parts List

Note

Contact your Emerson sales office for Part Ordering information.

Key	Description
1	Body
6	Bonnet
20	Nozzle Body Flange
21*	Control Cage
22*	Control Plug
23*	Stem
24	Seat/Seat Diffuser
25	Plug Retainer
30*	Spray Nozzle
37	Nozzle Sleeve
43*	Cage Gasket, (2 req'd)
44	Bonnet Gasket
45*	Piston Ring
46*	Bore Seal Ring
47*	Nozzle Sleeve Gasket
48*	Nozzle Body Flange Gasket
52	Bonnet Stud Washer
53*	Stem Pin
54	Bonnet Stud
55	Bonnet Stud Nut
57	Nozzle Body Flange Stud
58	Nozzle Body Flange Stud Nut
59	Nozzle Body Flange Washer
60	Actuator Stud
61	Actuator Stud Nut
63*	Packing Box Ring
64*	Packing Set
65*	Packing Follower
66*	Packing Flange
68*	Hex Nut
69*	Stud
75*	Gasket
76*	Seat Ring Cap Screws
77	Diffuser

Figure 9. Fisher CVX Assembly with Welded Seat Ring and Welded Diffuser

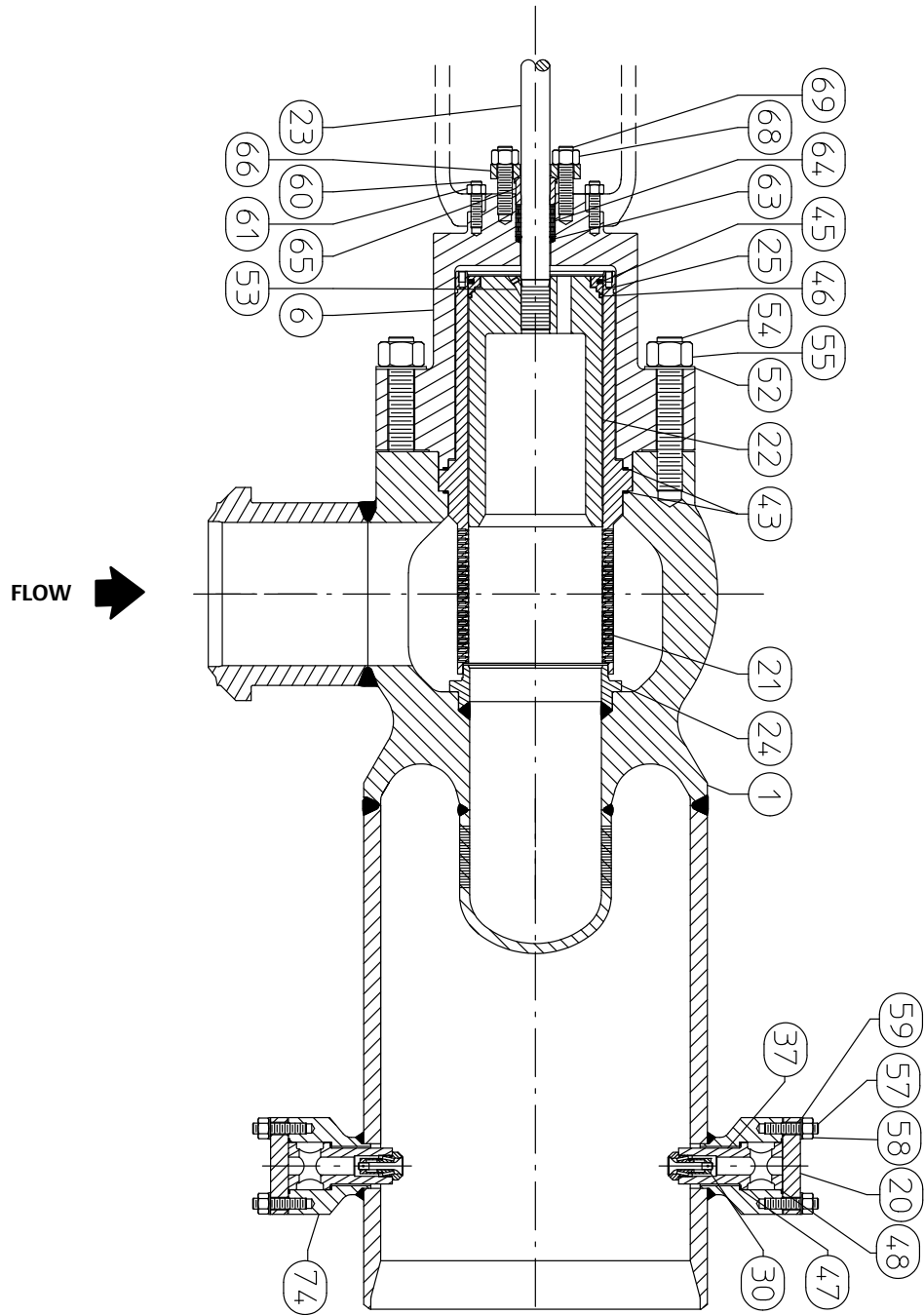

Figure 11. Fisher CVX Assembly with Bolted Seat Ring and Bolted Diffuser

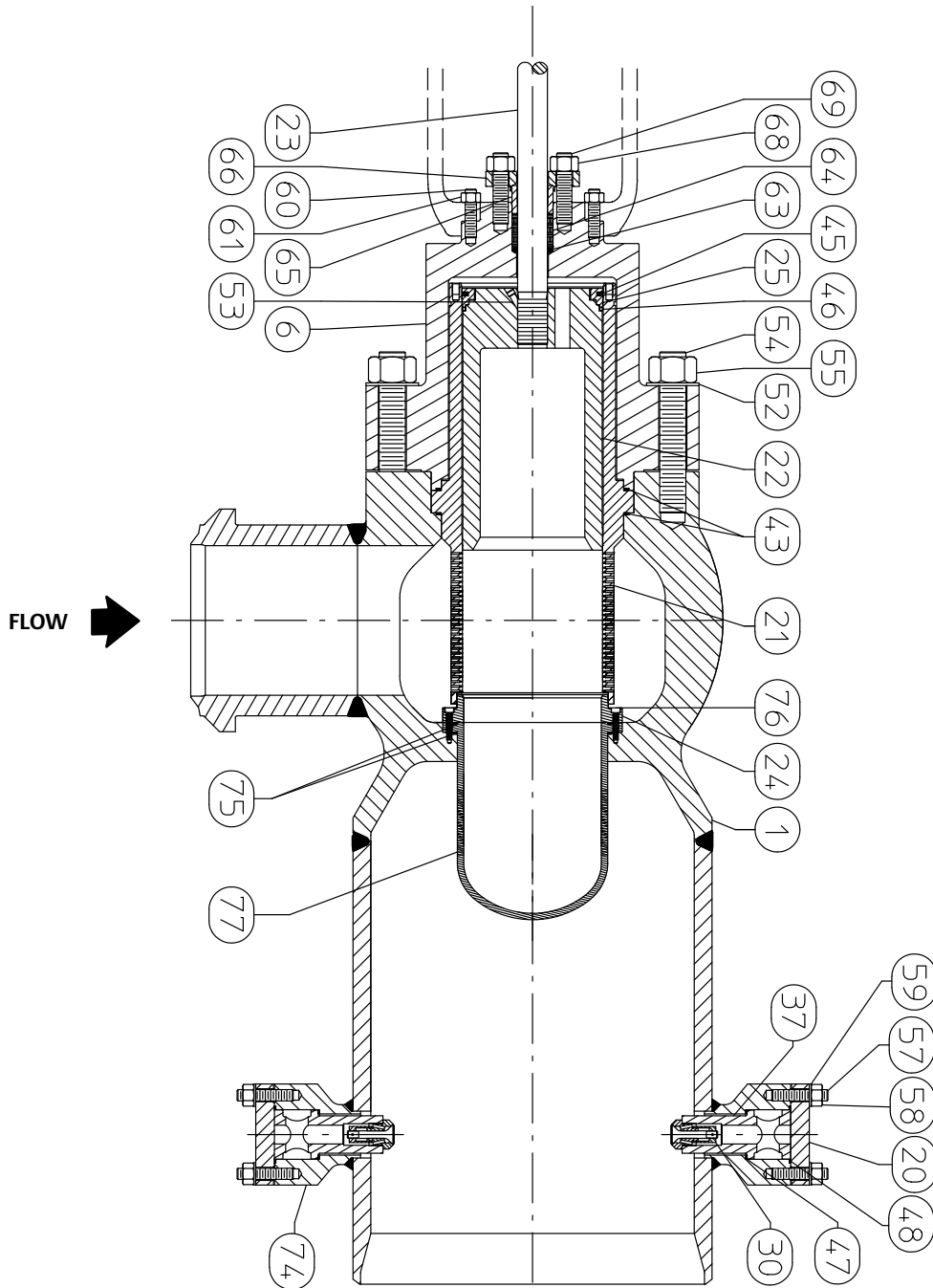
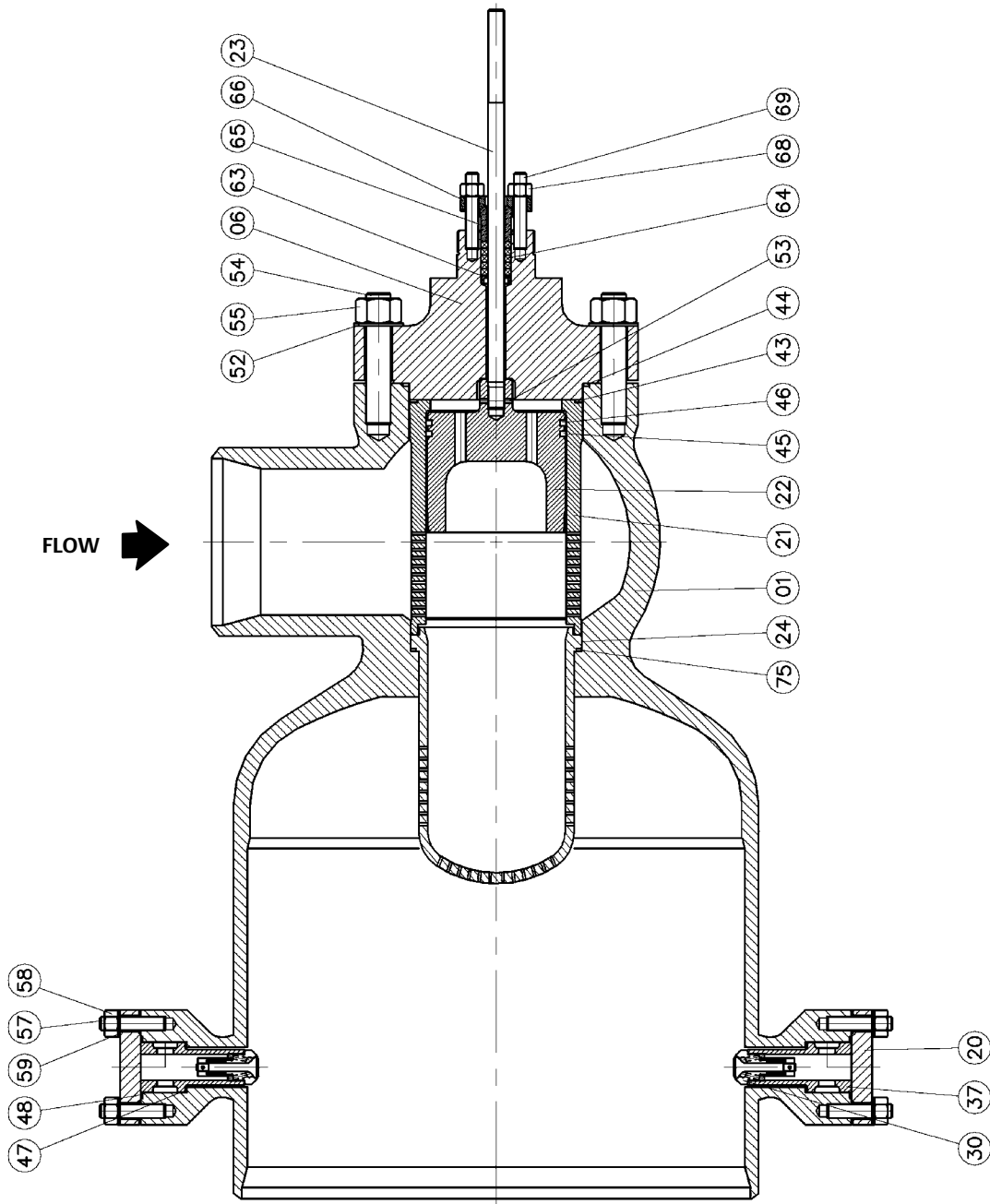
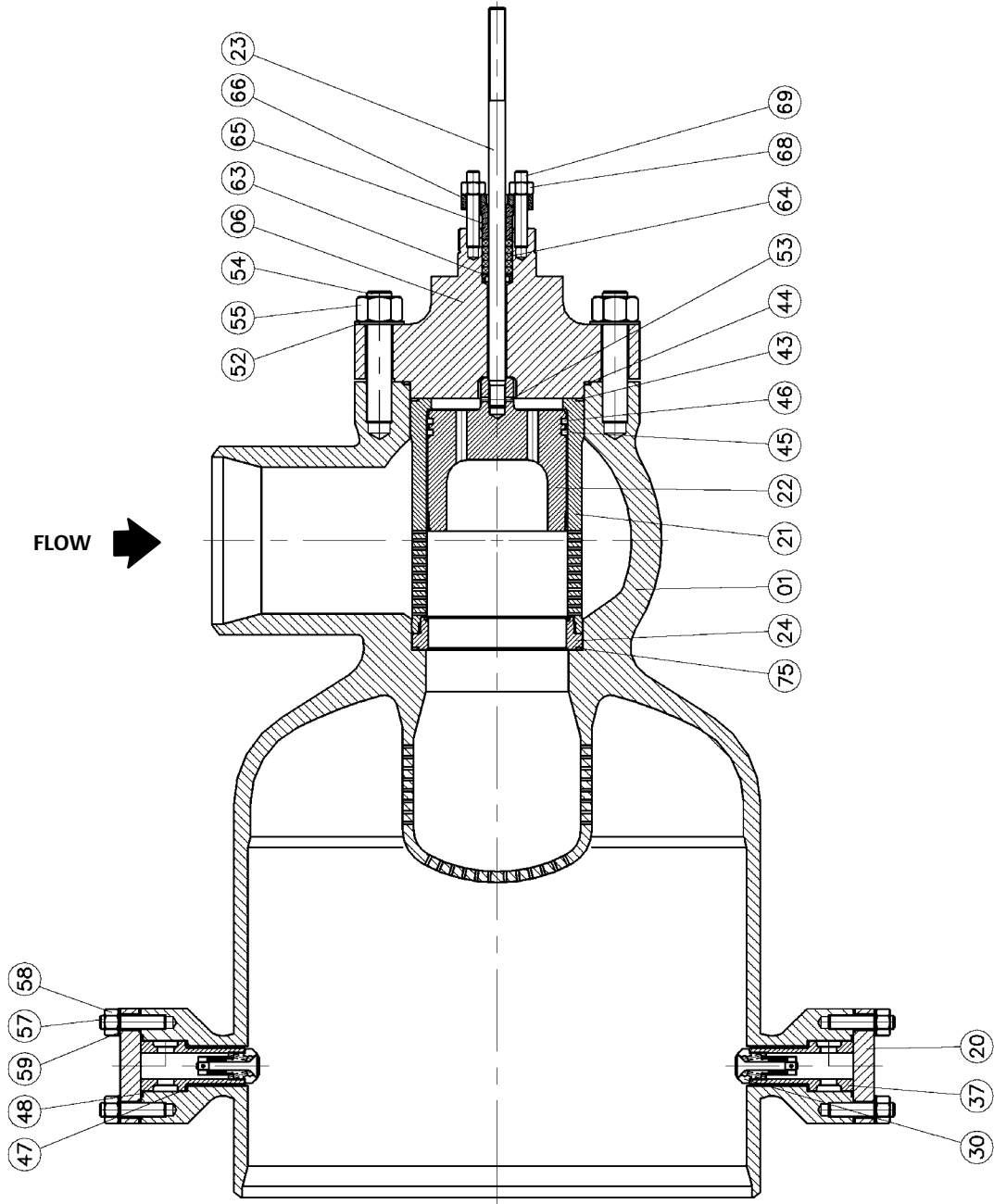

Figure 12. Fisher CVX Assembly with Clamped Seat Ring and Diffuser



E1829

Figure 13. Fisher CVX Assembly with Clamped Seat Ring and Welded Diffuser



E1828

Neither Emerson, Emerson Automation Solutions, nor any of their affiliated entities assumes responsibility for the selection, use or maintenance of any product. Responsibility for proper selection, use, and maintenance of any product remains solely with the purchaser and end user.

Fisher and Whisper Trim are marks owned by one of the companies in the Emerson Automation Solutions business unit of Emerson Electric Co. Emerson Automation Solutions, Emerson, and the Emerson logo are trademarks and service marks of Emerson Electric Co. All other marks are the property of their respective owners.

The contents of this publication are presented for informational purposes only, and while every effort has been made to ensure their accuracy, they are not to be construed as warranties or guarantees, express or implied, regarding the products or services described herein or their use or applicability. All sales are governed by our terms and conditions, which are available upon request. We reserve the right to modify or improve the designs or specifications of such products at any time without notice.

Emerson Automation Solutions
Marshalltown, Iowa 50158 USA
Sorocaba, 18087 Brazil
Cernay 68700 France
Dubai, United Arab Emirates
Singapore 128461 Singapore

www.Fisher.com



Free Manuals Download Website

<http://myh66.com>

<http://usermanuals.us>

<http://www.somanuals.com>

<http://www.4manuals.cc>

<http://www.manual-lib.com>

<http://www.404manual.com>

<http://www.luxmanual.com>

<http://aubethermostatmanual.com>

Golf course search by state

<http://golfingnear.com>

Email search by domain

<http://emailbydomain.com>

Auto manuals search

<http://auto.somanuals.com>

TV manuals search

<http://tv.somanuals.com>