



# VILTech micro-controller

## Operation and service manual





## Important Note:

  	<p><b>⚠ DANGER</b></p> <p>Read and understand operator's manual before using/ servicing this machine.</p> <p>Failure to follow operating instructions could result in serious injury Possible Electrocution or burn.</p> <p>Follow lockout/tag out procedures before working inside this equipment.</p>
---	---

Before applying power to the control panel, all wiring to the panel should be per NEC. Specifically check for proper voltage and that the neutral is grounded at the source. An equipment ground should also be ran to the panel.

\*See Wiring Instructions and Diagrams before proceeding.

**Before start-up, enter all system values and options. See section on Setpoint Values.**

# Table of Contents

Important Note: .....	3
Domestic Terms and Conditions .....	10
Export Terms and Conditions .....	12
<b>Chapter 1 .....</b>	<b>11</b>
Spare Parts List .....	12
Pre-Startup Check List .....	13
Retrofit Kit Instructions .....	14
Operating Procedures .....	19
Definitions .....	19
Keypad Functions .....	20
Main Screen Overview .....	22
Screen Types .....	23
Menu Screens .....	23
Menu Option Selection .....	24
Data Entry Screens .....	24
Cursors .....	25
Data Entry Procedures .....	25
Data Screen Keys .....	25
Field Types .....	26
Selectable Fields .....	26
Numerical Data Input Fields .....	26
Absolute Pressure Fields .....	27
Time Fields .....	27
Date Fields .....	27
String Fields .....	28
Telephone Number Field .....	28
Hexadecimal Fields .....	28
Status Screens .....	30
Confirmation Screens .....	31
Confirmation Screen Procedures .....	31
Momentary Screens .....	32
Information Screens .....	33
Access Screens .....	34
Log Screens .....	35
Alarms & Failures .....	36
Modes Of Operation .....	39
<b>Chapter 2 .....</b>	<b>39</b>
Compressor Controls .....	39
Starting the Compressor .....	40
Manual Start .....	40
Automatic Start .....	40
Remote/Auto Remote Start .....	41
I/O Control .....	41
Network Control .....	41
Sequenced Start .....	41
Stopping the Compressor .....	42
Manual Stop .....	42
Automatic Stop .....	42
Remote/Auto Remote Stop .....	42
I/O Control .....	42
Network Control .....	42
Sequenced Stop .....	42

Capacity Control .....	43
Manual Capacity Control .....	43
Automatic Capacity Control .....	43
Control Groups .....	44
Cut-Out Setpoint .....	44
Cut-In Setpoint .....	44
Control Setpoint .....	44
Low Alarm/Failure Setpoints .....	44
Time Proportional Control Strategy .....	44
Control Deadband .....	44
Normal Bandwidth .....	44
Normal Stage Delay .....	44
Fast Stage Delay - .....	44
Difference Above Setpoint .....	45
Load Bandwidth .....	45
Unload Bandwidth .....	45
Difference Below Setpoint .....	45
Remote Capacity Control .....	45
Auto-Remote Capacity Control .....	45
Sequenced Capacity Control .....	46
Low Alarm and Failure Setpoints .....	46
Running in Trim Mode .....	46
Running in Full Load Mode .....	47
Anti-Cycle in Sequenced Mode .....	47
Forced Unloading & Limiting .....	47
Ramp Start .....	47
Capacity Ramp Start Limiting .....	48
Staging Setup .....	49
Minimum Capacity .....	49
Setpoint Scheduling .....	50
Daily Schedules .....	50
Weekly Schedule .....	50
Oil Pressure Computation .....	50
Oil Temperature Regulation .....	50
Anti-Cycle Timer .....	51
Power Fail Restart .....	51
Process Temperature Control (Option) .....	51
Two Stage Configuration (Option) .....	51
Operational Procedures .....	52
Status Screens .....	54
Compressor Main Status Screen .....	54
Status Banner .....	55
Current System State .....	56
CURRENT STATE DESCRIPTION .....	56
Mode Area .....	56
MODE DESCRIPTION .....	56
Alarm & Failure Area .....	57
ALARM SYSTEMS STATUS .....	57
MESSAGE .....	57
Operating Hours Screen .....	57
TERM DEFINITION .....	57
Active Alarms & Failures Status Screen .....	58
Active Alarms & Failures Status Screen Definitions .....	58
Active Alarms & Failures Status Screen .....	58
Auto-Start Warning Screen .....	59

SETPT Hot Key .....	59
AUTO Start Warning Screen .....	59
SETPT Hot Key Screen .....	59
<b>Setpoints .....</b>	<b>60</b>
Pressure Setpoints .....	61
Suction Pressure Control Groups .....	61
High Suction Pressure Setpoints .....	63
Discharge Pressure Setpoints .....	64
Oil Pressure Setpoints .....	65
Intermediate Pressure Setpoints (Two Stage only) Option .....	66
Temperature Setpoints .....	67
Discharge Temperature Setpoints .....	67
Oil Temperature Setpoints .....	68
Process Temperature Control Group .....	69
High Process Temperature Setpoints .....	70
Note Page .....	71
Capacity Setpoints .....	72
Scheduling .....	73
Control .....	73
Active Group .....	74
Active Schedule .....	74
Weekly Schedule .....	75
Daily Schedule .....	75
CAP Control .....	77
Suction Pressure Control Setpoints .....	77
Process Temperature Control Setpoints .....	78
MISC Control .....	79
LOGS Hot Key .....	80
MENUS Hot Key .....	80
<b>Chapter 3 .....</b>	<b>81</b>
Logging Functions Technical overview .....	81
Logging Functions .....	81
Trend Log .....	82
Alarm Log .....	82
Failure Log .....	82
User Log .....	82
Logging Functions Operating Procedures .....	83
Operations and Trend Logs .....	84
Alarm and Failure Logs .....	85
User Log .....	86
Clear Logs .....	86
Clear All Logs .....	87
Set Log Rate .....	87
Logon User .....	89
Logoff User .....	89
Automatic Log Off .....	89
<b>Chapter 4 .....</b>	<b>89</b>
Menu Functions .....	89
Set-up Menu .....	91
Set Clock .....	91

Calibrate Sensors .....	91
Dynamic Sensor Calibration .....	91
Static Sensor Calibration .....	91
Passwords .....	92
Adding/Deleting Users .....	92
Screen Access Levels .....	92
Initialization .....	92
Power Fail Reset .....	92
Set Factory Configuration .....	93
Configuration .....	93
Display .....	93
Communication .....	93
Set Operating Status .....	93
Staging Configuration .....	93
Control Configuration .....	93
Adjust Contrast .....	93
Operational Procedures .....	94
Logon User .....	95
Logoff User .....	95
Diagnostics .....	96
System Information .....	96
View Discrete I/O .....	97
View Analogs .....	98
Communication Status .....	100
Override Discrete I/O .....	101
Set-up .....	102
Set Clock .....	102
Calibrate Sensors .....	103
Dynamic Sensor Calibration .....	104
Static Sensor Calibration .....	105
Password Control .....	106
Password Control Screen .....	106
Add/Delete User .....	107
Access Levels .....	108
Initialization .....	109
Power Fail Reset .....	109
Set Factory Config .....	110
Setpoint Save/Restore .....	110
Save/Restore Status .....	110
Configuration .....	111
Display .....	111
Comm Setup .....	112
Set Op Stats .....	113
Setup Stages .....	114
Control Configuration .....	115
Adjust Contrast .....	115
Variable Frequency Drive Option .....	116
<b>Sequencer Control.....</b>	<b>118</b>
Sequencer Technical Section .....	118
Sequencer System Control Parameters .....	119
Sequencer Staging Control .....	119
Difference Above Setpoint .....	120

Load Bandwidth .....	120
Unload Deadband .....	120
Unload Bandwidth .....	120
Sequencing Commands .....	120
System Control Parameter and Setpoint Communication .....	120
Sequencer Operations .....	121
Sequencer Lead List .....	121
Enabling and Disabling the Sequencer .....	124
Sequencer Control Groups .....	124
Sequencer Setpoint Scheduling .....	124
Alarm and Failure Setpoints .....	125
Setting up VILTech Panels for Sequencing .....	125
Sequencer Operating Procedures .....	126
Sequencer Status Screen .....	126
SEQ Hot Key .....	127
LEADLIST .....	127
CNTRLGROUPSELECT .....	127
SCHEDULING .....	127
SCHEDULESETUP .....	127
DAILY SCHEDULE .....	127
SCHEDULE01 .....	127
SCHEDULE02 .....	127
SCHEDULE07 .....	127
HIGH ALARM .....	127
LEAD LIST A .....	127
LEAD LIST B .....	127
CURRENT ACTIVE LEAD LIST .....	131
Control Group Select .....	132
CONTROL SETPT .....	132
LOW ALARM .....	132
LOW FAILURE .....	133
Schedule Setup .....	133
Daily Schedules .....	134
SCHEDULED TIME .....	134
SELECTED GROUP .....	134
SELECTED LEAD .....	134
LIST .....	134
High Alarm .....	135
Addendum for Pump Down Program for VILTech .....	136

**APPENDIX A ..... 139**

Alarm and Failure Data .....	139
Analog Alarms .....	139
High Suction Pressure .....	139
Low Suction Pressure .....	139
High Discharge Pressure .....	139
High Oil Temperature .....	139
Low Oil Pressure .....	139
Low Intermediate Temp(Two Stage) .....	139
High Process Temperature(Option) .....	139
Low Process Temperature(Option) .....	139
High Intermediate Pressure (Two Stage) .....	140



Low Intermediate Pressure (Two Stage) .....	140
Discrete Alarms .....	140
<b>APPENDIX B .....</b>	<b>141</b>
Analog and Discrete I/O .....	141
Analog Inputs .....	141
<b>APPENDIX C .....</b>	<b>143</b>
Communication Protocols .....	143
Introduction .....	143
Applicable Documents .....	143
Hardware Interface Description .....	144
Hardware Requirements .....	144
Interface Connections .....	144
Pin Name .....	144
Message Addressing .....	146
Software Interface Description .....	148
Protocol Overview .....	148
Status Only or Status and Control Options .....	148
Message Categories .....	148
MODBUS Protocol Description .....	149
Preset Single Register .....	150
Preset Multiple Registers .....	150
Error Messages .....	151
Data Formats .....	151
Status Message Description .....	152
Analog Input and Computed Parameters .....	152
Discrete Input and Outputs .....	153
Alarm and Failure Data .....	154
Equipment Data .....	157
Alarm Status Table .....	157
Compressor Mode Table .....	157
Compressor State Table .....	158
Last RECIP Start Status Table .....	160
Control Message Description .....	160
Network in Control Command .....	161
Compressor Start/Stop .....	161
Set Compressor Capacity Command .....	162
Change Compressor Mode Command .....	162
Acknowledg/Clear Active Alarm Command .....	163
Change Current Setpoint Group Command .....	163
Change Control Type Command .....	163
Auto Start/Stop Control Command .....	163
Suction Pressure Setpoint Message Description .....	164
Process Temperature Setpoint Message Description .....	165
<b>APPENDIX D .....</b>	<b>166</b>
Condensor Control .....	166

# *Notes Page*



# *Spare Parts List*

QNTY	Part#	Item
1	3400A	Microcontroller Board
1	3400B	I/O (Digital and Analog) Board
1	3400C	Display Interface Board
1	3400CG	240x128 Liquid Crystal Display
1	3400F	Controller Fuse Pack Consisting of 1-15amp main, 3-5amp I/O
1	400K	Controller Power Supply
2	3400M	120VAC Solid State Output Module
2	3400N	120VAC Solid State Input Module
1	3400R	EEPROM
1	3400Y	Cable Kit (incl display cable, p.s. to main, p.s. to I/O bd)
1	2611N	DETECTOR -58/122DEG TEMP RESIST 4-20MA
1	2611P	DETECTOR 32/392DEG TEMP RESIST 4-20MA
1	2783D2	TRANSDUCER AKS33 0-414.5PSIA 4-20MA OUT
1	2783D4	TRANSDUCER AKS33 0-200PSIA 4-20MA OUT
2	3122B	CORDSET RK4T-4/S618 TURCK

## Chapter 1

# *Pre-Startup Check List*

**Pre-Wired done at factory. The necessary field wiring connections are described below.**

1. Connect power (L1) to e-stop at terminal #2. Then neutral is connected on TB5 to the middle terminal labeled “N”. Last connect ground on TB5 at the right end terminal labeled “G”.
2. Connect the Compressor Motor to Channel 1, the hot lead connects to terminal 4 and the neutral end to terminal 1.
3. Connect the Motor Starter AUX to Channel 9. The hot side of the dry contact to terminal 34. The neutral side of the dry contact to terminal 35.
4. At this time connect AUX #1, AUX #2, Remote Start/Stop, or water solenoid that may have shipped loose per the wiring diagram.
5. First, press “Menu” key then press “#1” then next press “clear” now enter the password “999999”. Then enter setpoints by pushing “SETPT” key then #2 for Setpoints. Now go through each screen for 1.Pressure, 2.Temperature, and 3.Capacity. Use the “QUIT” or “SAVE” button to go to previous screen.
6. Still under “Setpt” screen setup Capacity Control by pressing #4 and Misc Control by pressing #5. If multiple control setpoints are going to be used then setup a Schedule by pressing #3, please read the manual for more information.
7. Now press the “Menu” button then press #4 “System Setup” then #5 “Configure Hardware” then #4 “Staging Configuration”, now on this screen please make sure that the correct steps of unloading are shown on the right side of the screen, if the steps are not correct then look in the manual or call Electrical Engineering at Vilter Manufacturing LLC. Now to get out of this screen press “Quit” key if no changes were done otherwise press “Save” to get to the previous screen.
8. Next press #5 “Control Configuration” and verify the refrigerant and enable/disable any options that are needed or not.

## Chapter 1

# Retrofit Kit Instructions

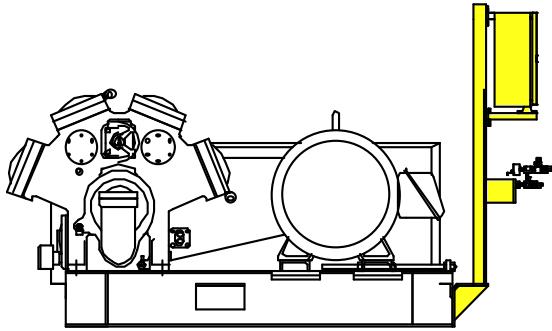

**Belt Drive**

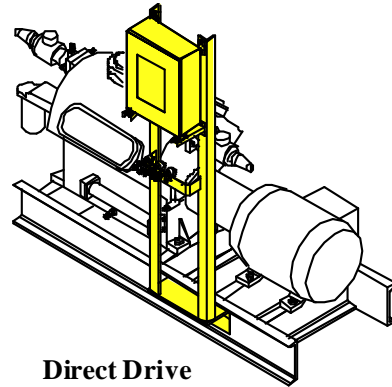

**Direct Drive**  
Mount Suction Side of Unit

### Remove Pressure Switches and Gauges

Remove existing pressure switches, and associated mounting bracket, tubing, fittings, hardware, and pressure gauges ①.

### Mount VILTech Frame on Compressor Base

Position the bottom edge of the VILTech frame flush with the bottom of compressor base. Mark and drill four (4) 0.8125" (13/16") holes. Mount the VILTech bracket to the compressor frame with four (4) 3/4" bolts and hardware provided ②. *If the compressor base is filled with concrete the bracket can be welded to the compressor frame.*

### Install Tubing for Pressure Transducers

Mount and install 1/4" steel tubing (provided by others) between pressure transducers and suction, discharge, and oil manifold connections ③. *Verify correct transducer pressure ranges: 0-200 psia suction; 0-414.5 psia discharge ; 0-200 psia oil manifold (0-414.5 psia intermediate on integral 2-stage compressors) ④. (Note: For 12 and 16 cylinder compressors, two discharge pressure transducers are provided. For integral 2-stage compressors, an intermediate pressure transducer is also provided.)*

### Install Wells and Mount RTD's

Install wells and mount RTD's for suction, discharge and oil temperature ⑤ (Note: For 12 and 16 cylinder compressors, mount discharge RTD in combined discharge line at outlet of oil separator.)

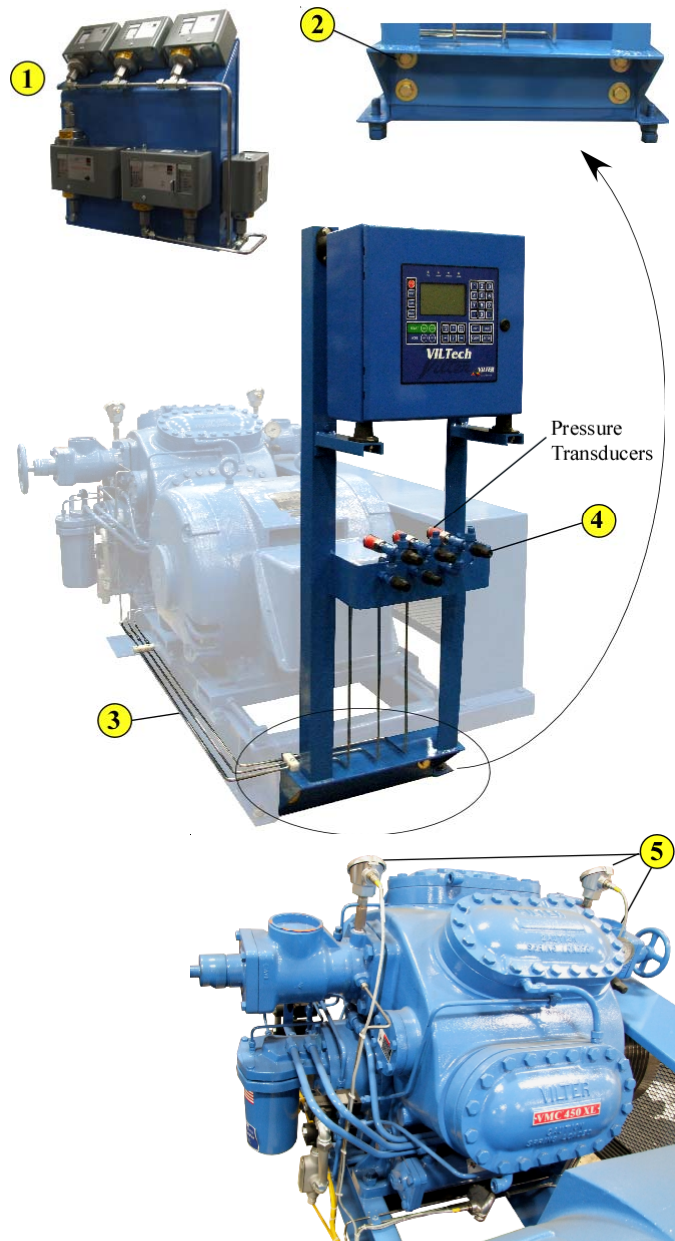

### Wire RTD's to VILTech

Wire grey turck cables (provided) from the RTD's to VILTech panel, according to wiring diagram. **6** DC cables from RTD's are to be wired through grommets on the left side of the bottom of the VILTech panel. **7** *Warning: Do NOT run AC and DC wires together!*

	<b>WARNING</b>
	Do not bring in or run any wiring on top of panel.
	Do not run DC voltage on the same side as the AC Voltage.  All 120V wires must enter the lower right corner of panel or all warranties will be void.

### Wire Solenoids and Accessories to VILTech

Wire yellow turck cables (provided) from solenoids to VILTech panel, according to wiring diagram. **8** Wire additional accessories to the VILTech panel including motor starter auxiliary contacts, high level contact(s), crankcase heater, and water solenoid valve. AC cables from solenoids and accessories are to be wired through grommets on the right side of the bottom of the VILTech panel. **9**

### Wire 120 VAC Power to VILTech

Wire 120 VAC power to VILTech panel, according to wiring diagram. AC cables from power are to be wired through grommets on the right side of the bottom of the VILTech panel. Warning: Do NOT run AC and DC wires together!

**Read VILTech Manual**

**Power Up VILTech Micro-Controller and Enter Setpoints**

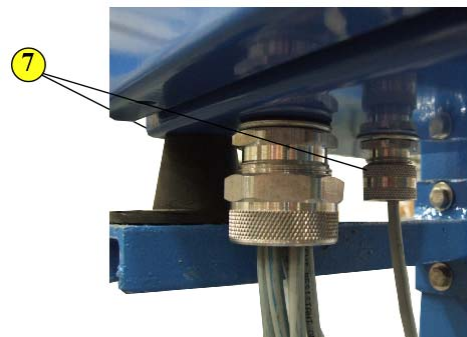
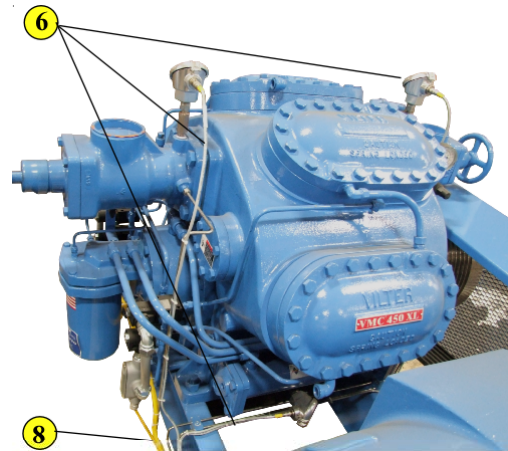

 **DO NOT RUN AC and DC wires TOGETHER!!!**

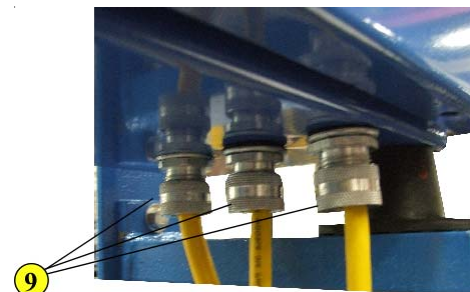

STANDARD CONFIGURATION

ANALOG INPUTS

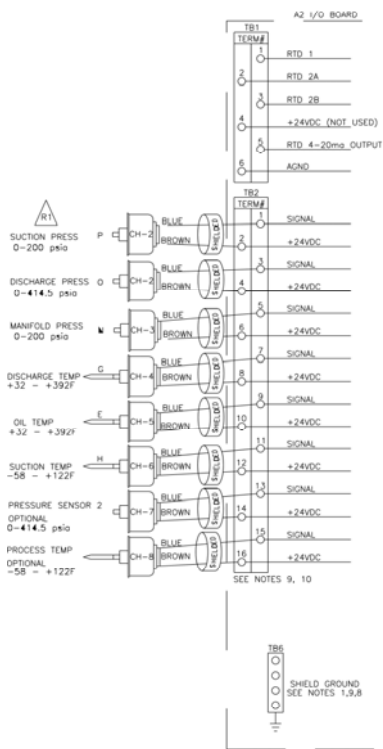

FORM "C" OUTPUTS

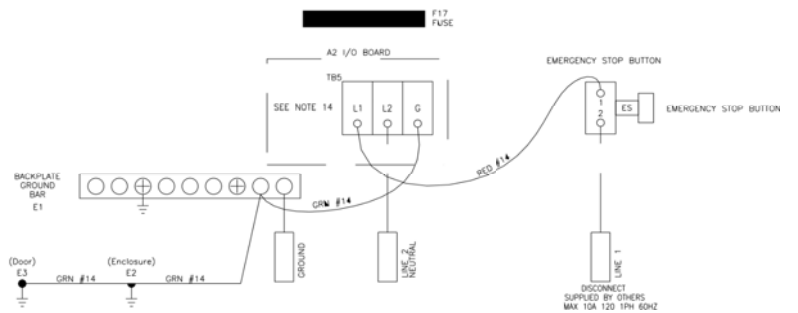
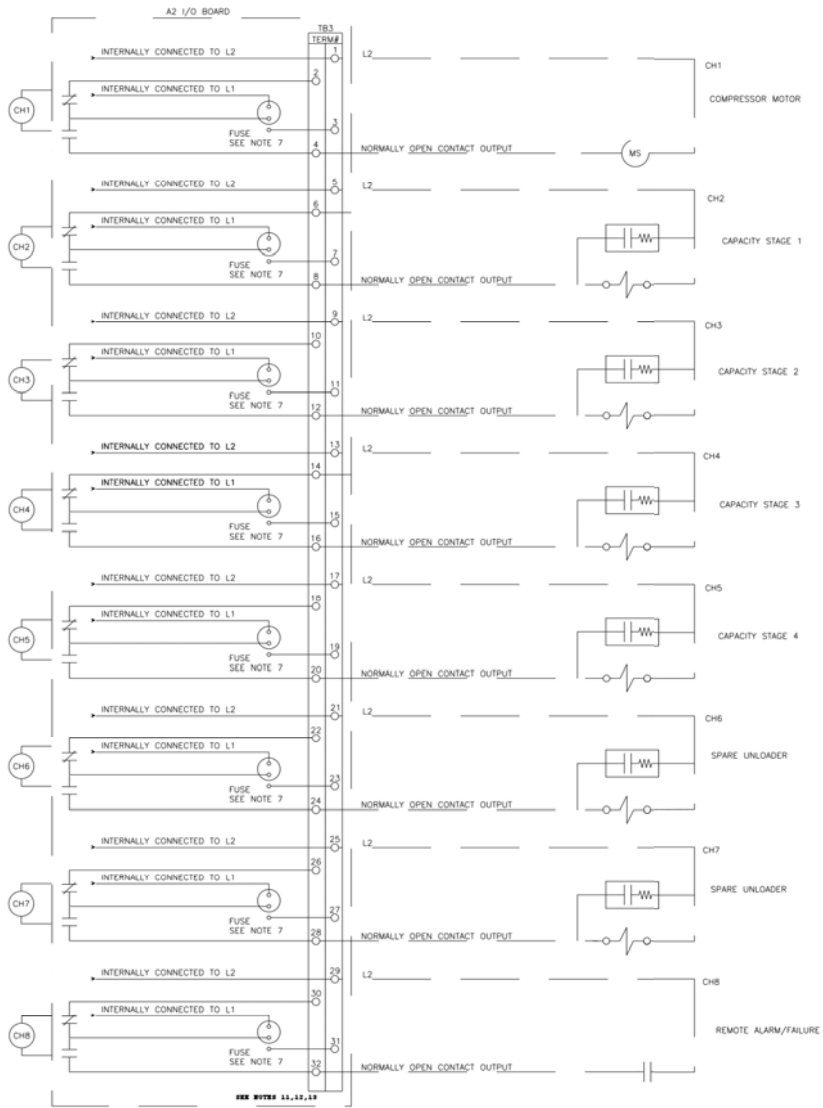



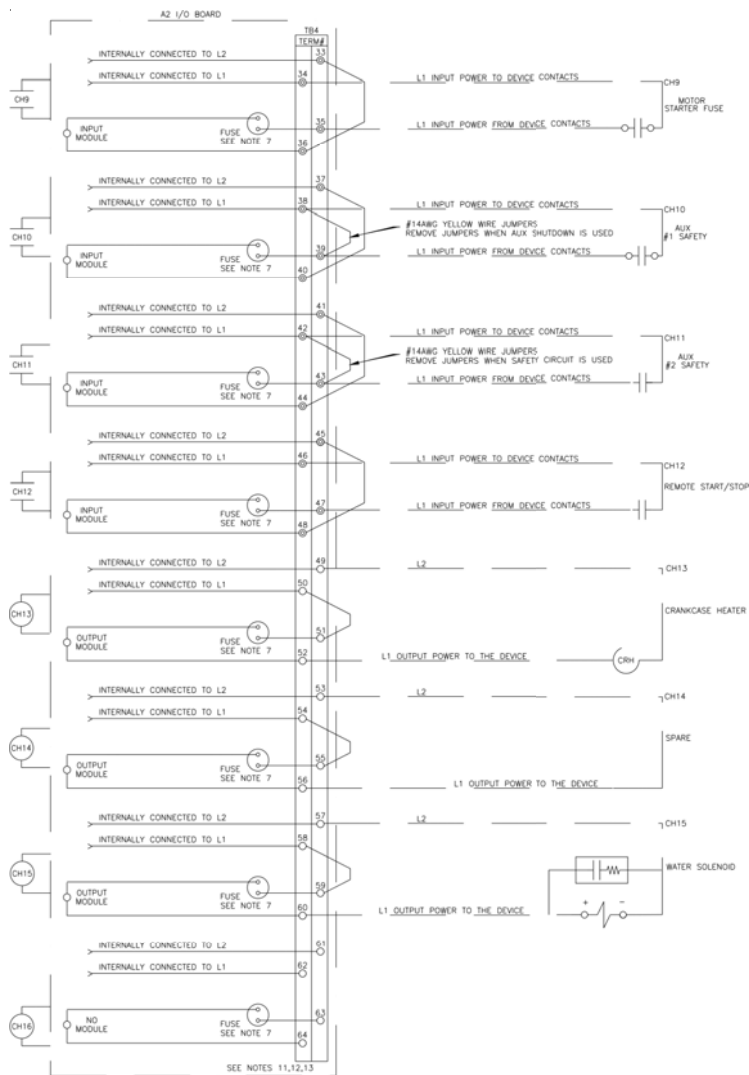

**NOTES:**

- 1) CONNECT ALL SENSOR DRAIN WIRES AT THIS LOCATION.
- 2) DOTTED WIRING REPRESENTS FIELD WIRING
- 3) DOTTED COMPONENTS NOT BY VILTER
- 4) FOR NEMA 3, 3R, 4 & 12 PANELS, ALL OPENINGS TO BE GASKETED.
- 5) MOTOR STARTER WIRING WILL VARY. REFER TO STARTER MANUFACTURER'S DIAGRAM FOR ACTUAL WIRING.
- 6) ALL CONDUIT CONNECTIONS TO THE PANEL MUST BE MADE WITH FLEXIBLE CONDUIT.
- 7) FUSE 5 AMP FAST BLOW.
- 8) ONLY (4) FOUR INCHES OF SIGNAL WIRES SHOULD BE UNSHIELDED AT SENSOR END.
- 9) CABLE FOR ANALOG DEVICES UNLESS SHOWN OTHERWISE IS BELDEN #9533 OR EQUIVALENT. 24 AWG, 3 CONDUCTOR, SHIELDED WITH DRAIN WIRE, RUN IN SEPARATE CONDUIT FROM POWER WIRING. MAX WIRE SIZE FOR TERMINAL IS #14AWG. USE COPPER CONDUCTORS ONLY WITH TEMPERATURE RATING 60°C OR HIGHER. TIGHTENING TORQUE 4 LB-IN.
- 10) MAXIMUM TOTAL SENSOR DRAW IS 2 AMPS. IF GREATER THAN 2 AMPS IS REQUIRED CUSTOMER SUPPLIED POWER SUPPLY IS REQUIRED. CONSULT MANUFACTURER FOR DETAILS.
- 11) MAX WIRE SIZE FOR I/O BOARD TERMINAL IS #12AWG. USE COPPER CONDUCTORS ONLY WITH TEMPERATURE RATING 60°C OR HIGHER. TIGHTENING TORQUE 4 LB-IN MAXIMUM CURRENT FOR FORM C RELAY IS 4 AMPS MAXIMUM CURRENT FOR SOLID STATE OUTPUT MODULE IS 1.5 AMPS.
- 12) DRAWING IS SHOWN WITH INTERNALLY SUPPLIED POWER ALTHOUGH IT IS CONFIGURABLE TO CUSTOMER SUPPLIED POWER.
- 13) 120 VAC OUTPUTS MAX. LOAD: 1.5 AM RUNNING, 30 AMPS INRUSH.
- 14) MAX WIRE SIZE FOR INPUT POWER TERMINAL IS #10AWG. USE COPPER CONDUCTORS ONLY WITH TEMPERATURE RATING 60°C OR HIGHER. TIGHTENING TORQUE 4.4-5.3 LB-IN.
- 15) CABLE FOR COMMUNICATION BETWEEN PANELS OR COMPUTER IS BELDEN #9843, OR EQUIVALENT. 24 AWG, 6 CONDUCTOR, TWISTED PAIR SHIELDED WITH DRAIN WIRE, RUN IN SEPARATE CONDUIT FROM POWER WIRING.



## Chapter 1

# *General Operating Procedures*

### Definitions

**Cursor** is a field indicator used on data entry screens. There are four possible cursor types:

- \* represents a number field input
- > represents a selectable field
- “ represents a string field
- X represents a hexadecimal field

The cursor shows the user which fields are changeable on a data entry screen.

**Display Area** is the part of the LCD display that shows system information. The display area will vary in size depending on whether a large character or small character screen is being viewed.

**Fields** are places where the user enters control parameters.

**Highlight** is when the letters appear light on a dark background instead of dark on a light background. The highlighted area may flash from light to dark to stress its importance and to gain the user's immediate attention.

**Hot Keys** are the top-level system functions and menus. The hot keys are located in a column to the left of the Display area.

**Large Character Screens** are screens that use large, double high characters and also contain the title banner and hot keys.

**Main Status Screen** is a large character status screen, which is considered the main system status screen. This screen will also contain the alarm status, mode, and state of the system.

**Parameter** is a system control value, which is displayed by the system or input by the user. Examples are suction pressure and high suction pressure alarm setpoint.

**Screen** is a method of displaying information to the user. The system contains eight types of possible screens: menu screens, data entry screens, status screens, confirmation screens, momentary screens, information screens, access screens, and log screens

**Small Character Screens** utilize the entire LCD display and use small characters to show system information. These screens do not display the system hot keys.

Toggle is the process of moving from one selectable choice to the next by using the ENTER key.

**User** is an individual or group of individuals who will use the system. A user is identified by a user number ranging from 1 to 10. The user may also be referred to as the operator in this document.

## Keypad Functions

The following is a brief summary of the Viltech keypad along with a description of its individual keys. Below is a drawing of the Viltech keypad layout.

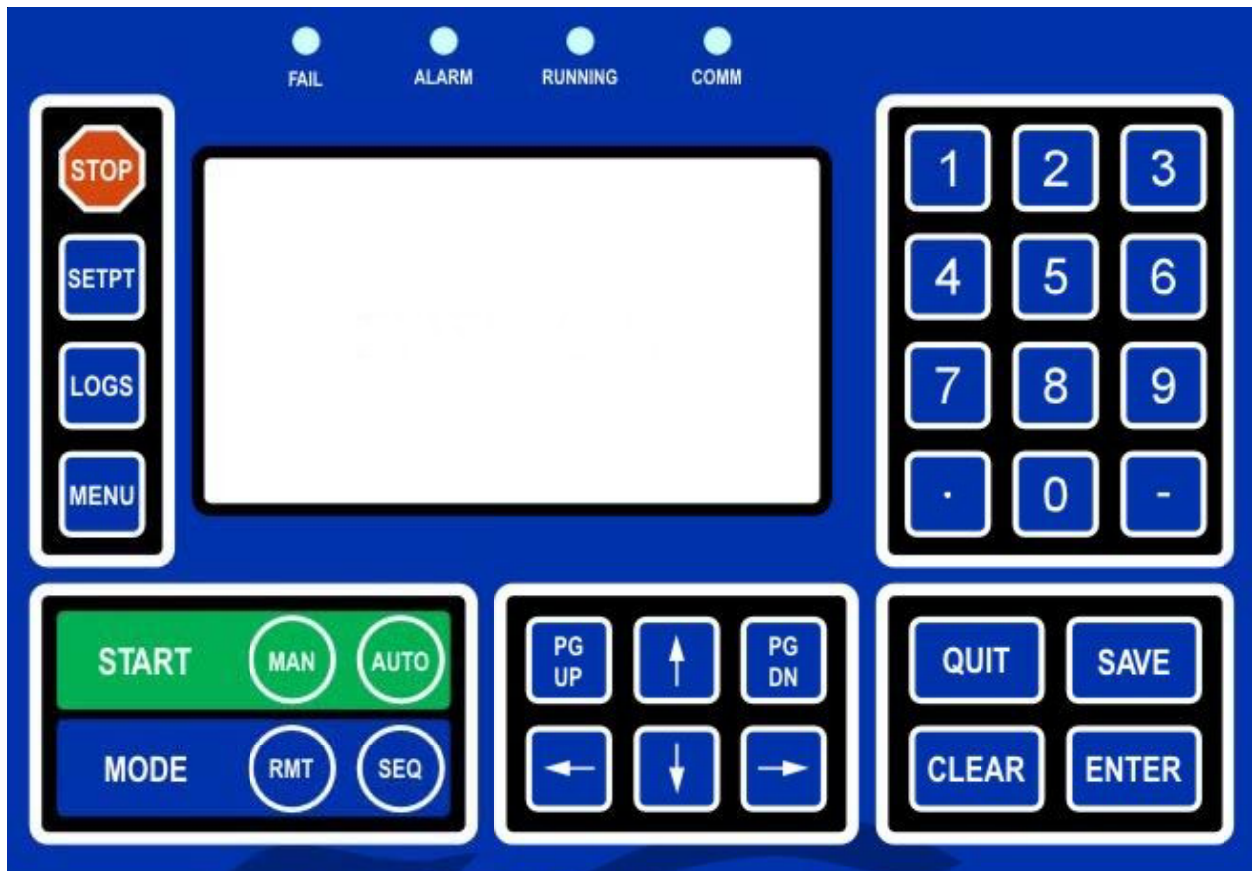

Keypad Diagram

**STOP** The red **STOP** key causes an immediate and orderly shutdown of a compressor. This key usually has no effect on master panels.

**0 – 9** The **NUMBER** keys select menu or hot key options. On data entry screens the number keys are used to enter numerical data.

- The **DOT** key allows decimal point entry on data entry screens. This key also permits the user to page forward one full screen at a time on log and status screens.

\_ The **MINUS** key allows negative number entry on data entry screens. This key also permits the user to page back one full screen at a time on log or status screens.

On data entry or menu screens, the **UP ARROW** key moves the cursor up to the next item on the screen.

On data entry or menu screens, the **DOWN ARROW** key moves the cursor down to the next item on the screen.

On data entry or menu screens, the **LEFT ARROW** key moves the cursor left to the next item on the screen. This key also permits the user to page forward one full screen at a time on log and status screens.

On data entry or menu screens, the **RIGHT ARROW** key moves the cursor right to the next item on the screen. This key also permits the user to page back one full screen at a time on log and status screens.

**PGUP** The **PG UP** key is used to page back one full screen at a time for status screens or to page up to more current data on log screens.

**PGDN** The **PG DN** key is used to page forward one full screen at a time for status screens or to page down to older data on log screens.

**QUIT** The **QUIT** key exits the current screen and displays the previous screen. Pressing the **QUIT** key to exit from a data entry screen will result all changed data being lost.

**SAVE** The **SAVE** key is used with data entry screens to save any changed information. It also exits the current screen and displays the previous screen.

**CLEAR** The **CLEAR** key within data entry screens will erase the current number field. On the main status or alarm status screen it acknowledges and clears alarms and failures.

**ENTER** The **ENTER** key is used within data entry screens on a number field to accept numerical data or on a selectable field to toggle through the available choices. On menu screens, the **ENTER** key will select the highlighted menu item. The **ENTER** key may also be used to scroll forward through the status screens.

## Main Screen Overview

The **MAIN SCREEN** is the name for a set of features common to all large character screens. The Main screen is broken down into two areas: the Display Area, and the Title Banner. The following drawing shows a representation of the main screen layout and labels each of its various areas.

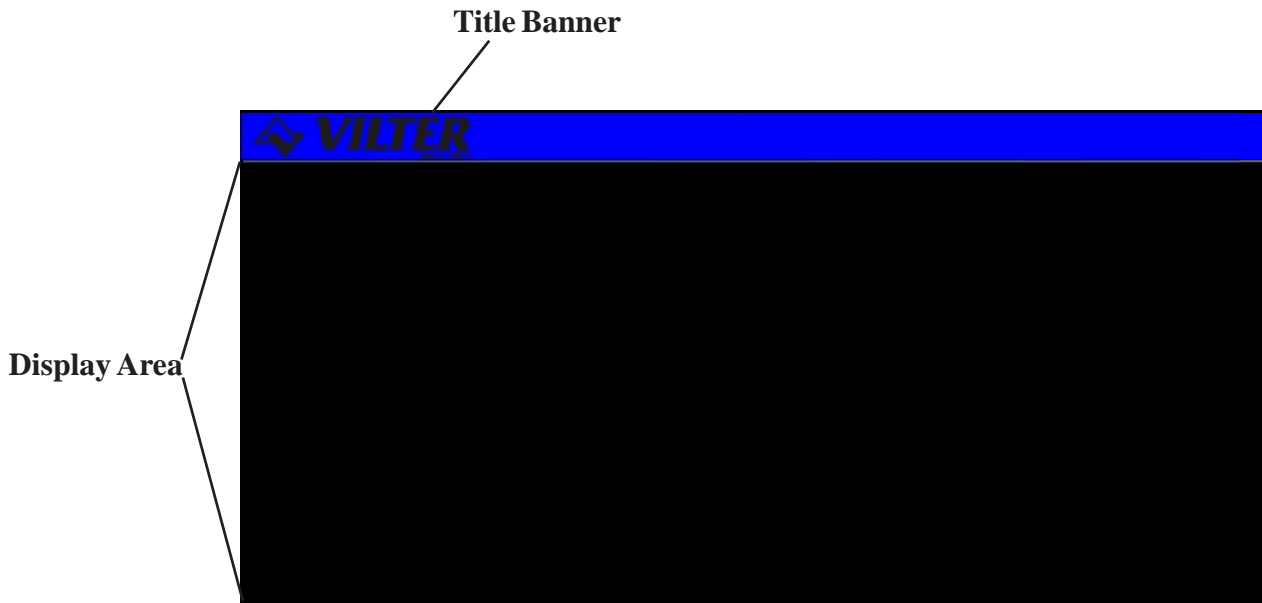

**Main Screen Layout**

**Title Banner** -The top highlighted bar contains the Vilter logo and the current time of day and may only be found on large character screens.

**Display Area** -Contains all of the detailed screen information. Large character screens will use only the designated display area, while small character screens use the entire LCD display.

## Screen Types

Viltech information is presented to the operator using eight different types of screens. The different **SCREEN TYPES** each use specific data entry and control procedures. The screen types let the user know which screen type heading to refer to for information on the specific screens' procedures. The following is a list of the eight different screen types.

**Menu Screen** - displays a numbered list of options.

**Data Entry Screen** - used to modify system control parameters.

**Status Screen** - displays real-time system summary data.

**Confirmation Screen** - used for verification, gives a choice for a yes or no option.

**Momentary Screen** - displays a message for three seconds.

**Information Screen** - used to display system information

**Access Screen** - a menu type screen with a number input field.

**Log Screen** - displays a record of system parameters and actions.

### Menu Screens

The **MENU** screen is used to present the user with choices for various system operations. Menu screens are found throughout the Viltech system. The following is an example of a menu screen.

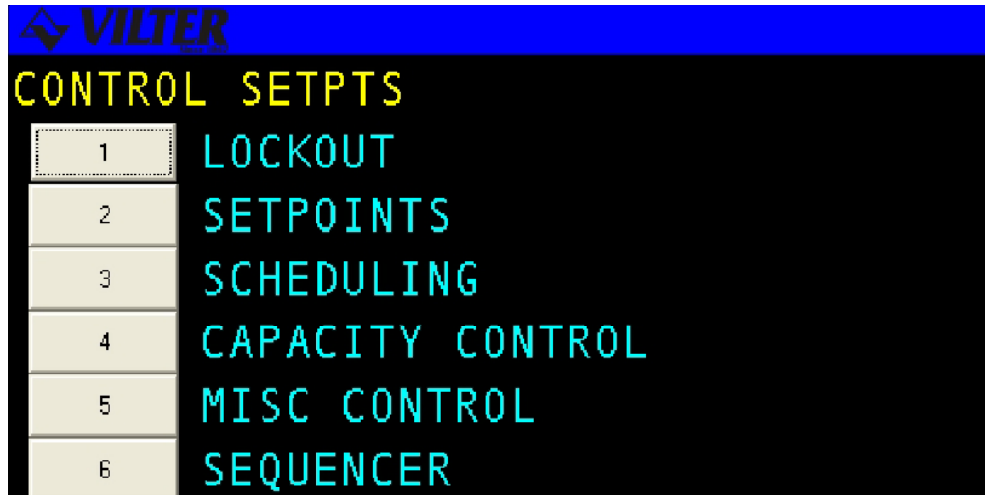

Menu Screen

The following table contains a list of the active keys on a menu screen and their function.

KEYS	FUNCTION
NUMBER KEYPAD	Used to choose a selection number.
ENTER	Used to choose the selection number that is highlighted.
UP/DOWN ARROW	Moves the cursor from one selection to the next either up or down.
QUIT	Exits from current screen to the previous screen.

### Menu Screen Keys Table

**Menu Option Selection** -Use the number keys corresponding to the desired menu item or the arrow keys and press ENTER to select the desired menu item.

### Data Entry Screens

**DATA ENTRY SCREENS** are user interactive screens, which allow the user to change or input system data. These screens contain a special cursor to signify the field type at the cursor location. The cursor can be moved throughout the screen to indicate each field location.

*NOTE: Data entry screens may also contain information for reference purposes that is not changeable. The following is an example of a data entry screen.*

OIL TEMPERATURE SETPOINTS		
HIGH FAILURE	155.0	DEGF
HIGH ALARM	140.0	DEGF
HEATER CONTROL	80.0	DEGF
LOW ALARM	60.0	DEGF
LOW FAILURE	55.0	DEGF

Data Entry Screen



The following table contains a list of the active keys on a data entry screen and their function.

<b>KEYS</b>	<b>FUNCTIONS</b>
<b>NUMBER KEYPAD</b>	Used to enter numerical data.
<b>ENTER</b>	Toggles through the available choices on a selectable field. On a number field the ENTER key is used to accept entered data and move to next field.
<b>ARROW KEYS</b>	Moves the cursor from one field to the next either up, down, left or right. Any of the arrow keys can also be used to accept the data entered on a number field.
<b>CLEAR</b>	Will clear the current numerical field. The CLEAR key is not active on selectable fields.
<b>SAVE</b>	Exits from the current screen and all new data is saved.
<b>QUIT</b>	Exits from the current screen and all new data is lost.

#### **Data Screen Keys**

A data entry screen may contain both numerical input and selectable fields, which are identified by different cursors as shown in the following table.

#### **Cursors**

>	Selectable cursor, indicated a selectable field.
*	Numerical input cursor, indicates a number field.

#### **Data Entry Screen Cursor Table**

### **Data Entry Procedures**

- 1. Verify Screen Type** - One of the special cursors must appear on the screen. If the cursor did not appear you are not on a data entry screen.
- 2. Change Fields** - Use the arrow keys to move the cursor to the desired field.
- 3. Enter Data** - Enter the desired numerical data or select the desired selectable depending on field type.
- 4. SAVE OR QUIT** - Upon completing the changing of data the user may press SAVE to save all newly entered data and return to the previous screen. If the user presses QUIT the entered data will not be saved. After pressing QUIT, confirmation screen will ask the user to verify the desire to lose all changes entered.

## Field Types

This section discusses the procedures used to work with each of the **FIELD TYPES** as well as the general procedures that apply to all number entry fields. The following information applies to any field when entering numerical data:

**Decimal Number Entry** -If the data you wish to enter has a zero in the decimal place there is no need to enter “0.” Simply enter the whole number value.

**Arrow Keys** - The arrow keys will accept the entered data and move the cursor to the next field.

**Errors** - The flashing error message tells the user that the entered data is not within an acceptable range for the field. The user must clear the error before proceeding. To clear an error message the operator presses the CLEAR key.

**Restoring Valid Data** -The user can clear and re-enter data from any field prior to leaving the field. If the arrow key or the ENTER key is used to move off the field after it has been cleared, the previously entered valid data will be restored to the field.

## Selectable Fields

A **SELECTABLE FIELD** gives the user a choice of inputs from which to toggle through and is recognized by the “>” cursor preceding it.

1. **Verify Cursor Type** - locate the “>” selection cursor.
2. **ENTER Key** - cycles the user through the available selections.
3. **Arrow Keys** - move to the next field and accept the selection.

## Numerical Data Input Fields

A numerical field is used to enter control data and is recognized by the “\*” cursor preceding it.

1. **Verify Cursor Type** - locate the “\*” numeric input cursor.
2. **Number Keypad** - press the number keys that correspond to the number you wish displayed. Use the decimal and minus keys where applicable. Each field will limit the user to a maximum number of whole and decimal numbers for that specific field.
3. **ENTER/Arrow Keys** -move to the next field and accept the entered number.
4. **Verify Cursor Type** - Upon pressing the ENTER or DOWN ARROW key, if the cursor moves across to the units column and changes to the “>” selectable cursor, the user is in a suction pressure field which is described in the next section.

### **Absolute Pressure Fields**

This field is actually a combination of numerical and selectable fields. The selectable or units section of the field allows the user to adjust the units to select vacuum or non-vacuum ranges.

- 1. Verify Cursor Type** - locate the “\*” numeric input cursor.
- 2. Number Keypad** - press the number keys that correspond to the number you wish displayed. Use the decimal and minus keys where applicable. If the numeric field already has the correct data and only the units need to be adjusted, re-enter the existing numerical data and press **ENTER**.
- 3. ENTER/Arrow Keys** - locks in the numerical data and moves the cursor across to the units section of the field.
- 4. Verify Cursor Type** - locate the “>” selection cursor next to the units section.
- 5. ENTER** - cycles between possible units selections.
- 6. Arrow Keys** - move to the next field and accept the entered data.
- 7. Errors** - If an error occurs because the value entered is out of range the CLEAR key will clear the field and return the user to the number portion of the field.

### **Time Fields**

The **TIME FIELD** is a special case numerical field used to enter time data.

- 1. Verify Cursor Type** - locate the “\*” numeric input cursor.
- 2. Number Keypad** - use the number keys to enter the time you wish displayed. For example, to input the time 5:59 press 0559, the system automatically moves from hours to the minutes. The “:” is automatically entered in a time field. This field will allow for whole number acceptance. For example to set the time 8:00 the user may type 08 and press **ENTER**. The time on the screen will appear as 08:00.

*NOTE: Time fields may be entered in 12-hour or 24-hour format depending on the system configuration. If the system is in 12-hour format the user will be prompted to select “AM” or “PM” using a selectable field after a number is entered.*

- 3. Arrow Keys** - move to the next field and accept the entered time.

### **Date Fields**

The **DATE FIELD** is a special case numerical entry field used to enter the date.

- 1. Verify Cursor Type** - locate the “\*” numeric input cursor.
- 2. Number Keypad** - use the number keys to enter the date you wish displayed. For example, to enter the date 1/1/91 the user would type in 010191, the system automatically moves from the month to the day and then to the year. The “/” slash symbol is entered for you.
- 3. Arrow Keys** - move to the next field and accept the entered date.

## String Fields

The **STRING FIELD** is a special case alpha-numeric entry field. It is similar to a selectable field but each character in the string may be selected from the list of all possible letters, numbers, and special characters.

1. **Verify Cursor Type** - locate the “ “ “ string input cursor.
2. **Enter Key** - Pressing the **ENTER** key first will clear the current contents and start entering characters. The **ENTER** key is primarily used to cycle through the available selections for the current character positions.
3. **“+” Key** - Selecting the *Positive* (.) key puts the field into edit mode and allows the current contents of the field to be entered.
4. **Arrow Keys** - Allows you to move within a field to different characters.
5. **Number Keys** - These keys are used to enter numbers into a character.
6. **Clear Key** - This key is used to clear the content of the entire field.
7. **Entering a space** - If a space is allowed in the field, an “\_” will be available in the character list. Selecting this character will result in a space being inserted in the string. All trailing spaces are eliminated.

## Telephone Number Field

The **TELEPHONE NUMBER FIELD** is a special case alpha-numeric entry field. It is similar to a string field but only allows numbers and several special characters required for telephone numbers.

1. **Verify Cursor Type** - locate the “ “ “ string input cursor.
2. **Enter Key** - Pressing the **ENTER** key first will clear the current contents and start entering characters. The **ENTER** key is primarily used to cycle through the available selections for the current character positions.
3. **“+” Key** - Selecting the *Positive* (.) key puts the field into edit mode and allows the current contents of the field to be entered.
4. **Arrow Keys** - Allows you to move within a field to different characters.
5. **Number Keys** - These keys are used to enter numbers into a character.
6. **Clear Key** - This key is used to clear the content of the entire field.
7. **Entering a space** - If a space is allowed in the field, an “\_” will be available in the character list. Selecting this character will result in a space being inserted in the string. All trailing spaces are eliminated.

## Hexadecimal Fields

The **HEXADECIMAL FIELD** is a special case alpha-numeric entry field. It is similar to a string field but only allows numbers and several special characters required for hexadecimal numbers.

1. **Verify Cursor Type** - locate the “ “ “ string input cursor.
2. **Enter Key** - Pressing the **ENTER** key first will clear the current contents and start entering characters. The **ENTER** key is primarily used to cycle through the available selections for the current character positions.
3. **“+” Key** - Selecting the *Positive*(.) key puts the field into edit mode and allows the current contents of the field to be entered.
4. **Arrow Keys** - Allows you to move within a field to different characters.
5. **Number Keys** - These keys are used to enter numbers into a character.
6. **Clear Key** - This key is used to clear the contents of the entire field.
7. **Entering a space** - If a space is allowed in the field, an “\_” will be available in the character list. Selecting this character will result in a space being inserted in the string. All trailing spaces are eliminated.



## Status Screens

**STATUS SCREENS** are used to display a summary of significant system information. The Main Status screen in a system is usually a large character text screen or graphics screen and is the default screen displayed on the LCD. The Main Status screen will be replaced by the Active Alarm and Failure screen when a new alarm or failure exists or by the Auto-Start Warning screen if the compressor is online and ready to start.

The operator may view each of the system's available status screens by scrolling through using the **ENTER**, **PG UP**, **PG DN**, **Right Arrow**, or **Left Arrow** keys. The number of status screens on a system will vary depending upon the individual system's configuration.

Another feature of the system is that it will automatically return to the main status screen after 10 minutes of no keyboard activity. Below is an example of a Status screen.

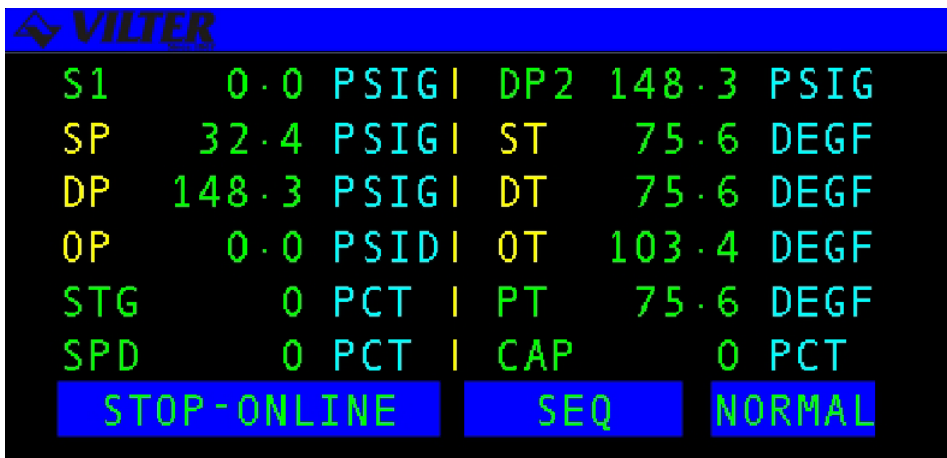

**Status Screen**

The following table contains a list of the active keys on a status screen and their function.

KEY	FUNCTION
<b>ENTER</b>	Scrolls through the set of available status screens.
<b>PG UP/PG DN RIGHT/LEFT ARROWS</b>	Pages forward or back through the available status screens.
<b>QUIT</b>	Returns the user to the main status screen.

**Status Screen Keys**

## Confirmation Screens

A **CONFIRMATION SCREEN** is used to ask the user to confirm a selection by answering a question. This screen usually appears after the user has altered system parameters and then presses the **QUIT** key or to verify a system control request. Below is an example of a confirmation screen.

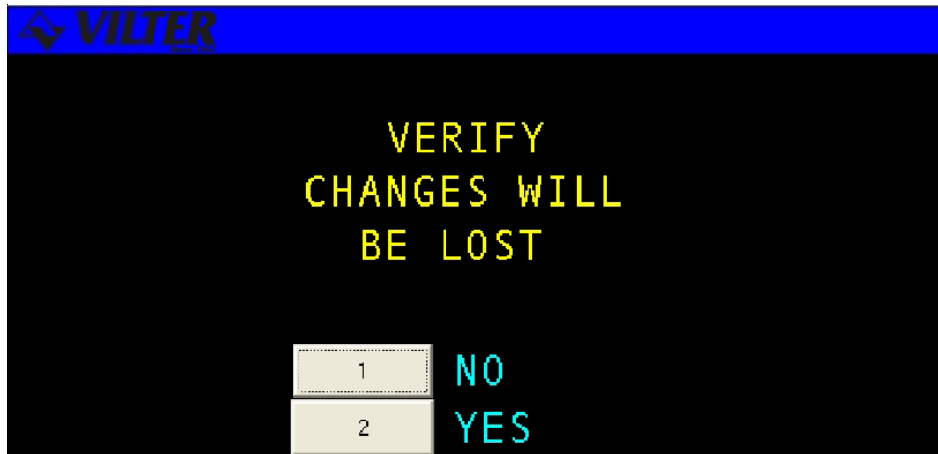

**Confirmation Screen**

The following table contains a list of the active keys on a confirmation screen and their function.

KEYS	FUNCTION
NUMBER KEYPAD	Used to select a response number
ENTER	Used to select the highlighted response number.
UP/DOWN ARROWS	Moves the cursor from one selection to the next, either up or down.
QUIT	Exits from the current screen to the pervious screen. Same as selecting NO for most screens or YES when quitting from a data entry screen after making changes.

**Confirmation Screen Keys**

### Confirmation Screen Procedures

**Number Keypad** -Use the keypad to match your response with the numerical choices shown on the screen or press **QUIT** to exit the screen.

## Momentary Screens

The **MOMENTARY SCREEN** is used to verify certain user selections by displaying an informative message for three seconds. Rather than waiting for the entire three second time to elapse, the operator may press the **QUIT** key to end viewing of the message. The following is an example of a momentary screen.



**Momentary Screen**

The following table contains a list of the active keys on a momentary screen and their function

<b>KEY</b>	<b>FUNCTION</b>
<b>QUIT</b>	Stops display of the message before the three second time limit expires.

**Momentary Screen Keys**



## Information Screens

**INFORMATION SCREENS** are used to display system data to the user. The information on these screens may be real-time data, or a snapshot of data at the time the screen is first displayed.

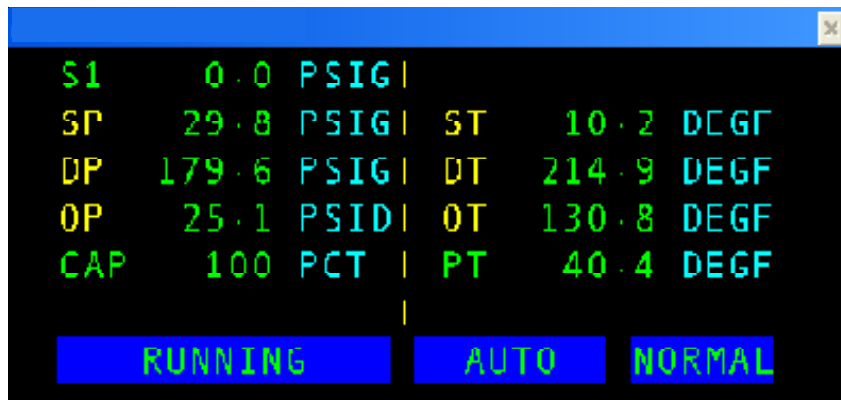

### Information Screen

The following table contains a list of the active keys on an information screen and their function.

KEY	FUNCTION
QUIT	Exits from current screen to the previous screen.

### Information Screen Keys

## Access Screens

The **ACCESS SCREEN** is used to index the user into a larger set of screens. This screen is typically used in cases where more than eight screens are available for a particular option. The access screen will perform error checking on the number entered. For example, if the screen is used to access the daily schedules and the number eight is entered, the input area will flash error since there are only seven possible schedules. The user will be required to clear the error and enter a correct value. The data entry process is described in more detail in the data entry section. The following is an example of an access screen.

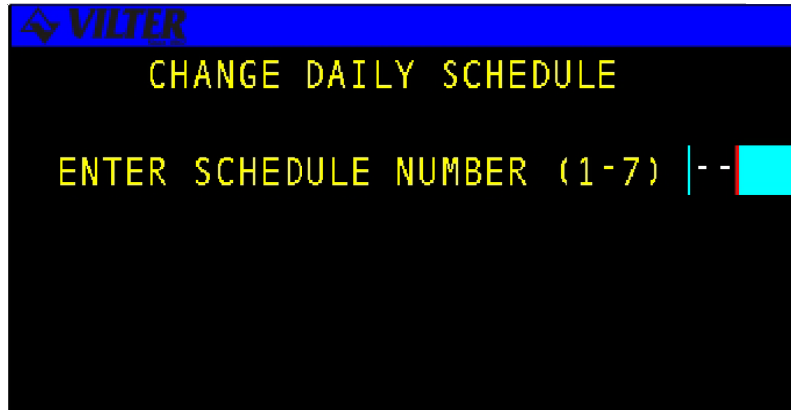

### Access Screen

The following table contains a list of the active keys on an access screen and their function.

<b>KEYS</b>	<b>FUNCTION</b>
<b>NUMBER KEYPAD</b>	Used to enter a number selection.
<b>ENTER</b>	Used to accept the selection number that is entered.
<b>QUIT</b>	Exits from current screen to the previous screen.

### Access Screen Keys

## Log Screens

**LOG SCREENS** are used to view recorded system information. The width and length of the log screens may be wider and longer than allowed by the LCD display area. The arrow and page keys can then be used to view the entire log. All systems are configured with the following logs: *Operation Log*, *Trend Log*, *Alarm Log*, *Failure Log*, and *User Log*. Other log types may also be included, depending on system options. Below is an example of a log screen.



**Log Screen**

The following table contains a list of the active keys on a log screen and their function.

KEY	FUNCTION
<b>PG UP</b> <b>PG DN</b>	Allows the user to page forward and back through the log entries. PG UP shows more recent log entries and PG DN shows older log entries.
<b>UP/DOWN</b> <b>ARROWS</b>	Scrolls line by line through the information. The Up arrow shows more recent log entries and the Down arrow shows older log entries.
<b>RIGHT/LEFT</b> <b>ARROWS</b>	Scrolls to additional log pages while maintaining the same time and date for log entries.
<b>CLEAR</b>	Returns the user to the beginning of the log.
<b>QUIT</b>	Exits from current screen to the previous screen.

**Log Screen Keys**

## Alarms & Failures

The **Viltech** continually monitors the system parameters and compares them to **ALARM AND FAILURE** setpoints to inform the operator of the system status. An alarm is intended to alert the operator that an undesirable condition exists. A failure is an indication that a more severe system condition exists and may cause the system or component to shutdown. The system parameters are compared to both operator-defined setpoints and Vilter Manufacturing, LLC. safety setpoints. An alarm or failure is detected when a system parameter is outside the acceptable range of the setpoints.

Certain alarms and failures may also be suppressed under specific conditions. For example, the low oil pressure alarm is suppressed when the compressor is not running. Additionally, the detection of certain alarms and failures can be delayed. For example, the low suction pressure failure is delayed for 10 seconds, in other words the suction pressure must be below the low failure setpoint for 10 consecutive seconds before the system is shutdown.

Some alarm and failure setpoints are assigned factory default values, which may not be changed by the operator. These are called OEM safety setpoints and typically indicate a condition that may cause damage to the equipment. A detailed list of all system alarms and failures can be found in Appendix A.

When an alarm or failure is detected the sequence of operations is as follows:

The equipment controlled by the Viltech may be stopped, as in the case of a compressor, when a failure occurs.

The alarm or failure is entered into the active alarm and failure list and the current status screen on the display is replaced with the active alarm and failure screen.

An entry is made in the appropriate alarm or failure log.

A special entry is made in the operation and trend logs listing the parameter values at the time of the alarm or failure.

The current alarms and failures present on a system can be viewed on the active alarms & failures status screen. The operator must acknowledge and clear alarms/failures from this screen or the main status screen using the procedures covered in this section.

When a new alarm or failure becomes active, the Active Alarm & Failure status screen will be displayed as the default status screen. The user can view all of the active alarms by scrolling through the alarms using the up and down arrow keys. An example of the alarm & failure status screen is shown on the next page.



### Active Alarms & Failures Status Screen

The active function keys for this screen are described in the following table.

KEY	FUNCTION
UP/DOWN ARROWS	Scrolls line by line through the information.
CLEAR	The CLEAR key is used to acknowledge and clear alarms/failures as well as to silence the alarm horn.

### Alarms & Failures Screen Keys

Use the following steps to acknowledge and clear any alarms & failures.

1. **Verify Screen Type** - The Alarm & Failure status screen or the Main Status screen should be displayed.
2. **Acknowledging an Alarm or Failure** - Press the **CLEAR** button. When the **CLEAR** button is pressed the previously flashing **ALARM** or **FAIL** in the lower right-hand corner of the screen will stop flashing and go to a constant highlight. This action will also deactivate the alarm or failure discrete output. When multiple alarms are active the acknowledging function operates on the entire set of active alarms or failures.
3. **Correct Problem** - The operator must now correct the problem causing the alarm or failure. This may be a control parameter that is out of range, or various other conditions which should be familiar to the operator.
4. **Clear Alarm or Failure** - Once the problem is rectified press the **CLEAR** button on the keypad. The Alarm & Failure status area should become non-highlighted and display the word **NORM**, the entry in the active alarm list will also be removed. The clearing of each alarm is processed when the conditions causing the alarm are acceptable.



## Chapter 2

# *Compressor Controls*

The following sections discuss the standard and optional features contained in the **Viltech RECIP** package.

## Modes Of Operation

The RECIP Compressor package has several modes of operation. The mode is changed by using the **MODE** key and making a selection from the Operation mode menu. The modes of operation are as follows:

- 1. Manual** - Starting, Stopping and Capacity Control are all performed manually.
- 2. Automatic** - Starting and Stopping can be performed manually or automatically based on Suction Pressure or Process Temperature. Capacity Control is performed automatically to maintain a specific control setpoint.
- 3. Remote** - Starting, Stopping and Capacity Control in the Remote mode can only be performed from a remote computer.
- 4. Auto-Remote** - Similar to the Automatic mode except starting and stopping are performed using the external Remote Start/Stop input or messages from a remote computer. The setpoint group can only be selected from a remote computer.
- 5. Sequenced** - This mode is utilized when two or more compressors are being used to control the same load.

*NOTE: The Remote, Auto-Remote, and Sequenced modes are available as system options.*

## Starting the Compressor

The sequence that the RECIP compressor goes through during a start is as follows.

1. A five second minimum start delay timer is started. During this time, the capacity stages are unloaded, the logs are enabled, and any discrete I/O overrides are cleared. The compressor is now in the **STARTING** state.
2. After the five second timer expires, the motor is started, the Cooling Control output is energized, and a 15 second up-to-speed timer is started. The user-programmable anti-recycle timer is also started at this time.
3. If the motor starter auxiliary contact closes within 15 seconds, the starting sequence will continue. Otherwise, the compressor will be shutdown. Also, low oil pressure alarms will be inhibited within the 25 seconds, pressure failure will be inhibited within 30 seconds.
4. When the 15 second up-to-speed timer expires, the compressor will be loaded to a point greater than or equal to the Minimum Capacity setpoint using the Fast Stage Delay Time between stages.
5. Once the compressor has loaded to minimum, the compressor transitions to the **RUNNING** state. Normal capacity control can now begin.

The RECIP Compressor can be started manually, automatically, or remotely based on the operating mode chosen. The compressor will not start in any mode if a failure condition exists.

## Manual Start

**MANUAL START** is accomplished by selecting the **MAN** key. A manual start is used in Manual mode.

## Automatic Start

In **AUTOMATIC START** the compressor can be started automatically based on suction pressure or process temperature. Automatic Starting is enabled on the Miscellaneous Control screen under the **SETPT** hot key. Once the Auto Start/Stop feature is enabled, the operator must place the compressor on-line using the **Auto** key. If the compressor is not needed at that time, it will immediately go to the Cut-Out state and will start automatically whenever required. If the control parameter is already above the Cut-In set-point, the compressor will start immediately. A failure or manual stop will take the compressor off-line.



## Remote/Auto Remote Start

### I/O Control

The **REMOTE START/STOP** input is used to start and stop the RECIP compressor in the Auto-Remote mode only. The compressor must first be placed on-line by the operator through the use of the **RMT** hot key. Once the compressor is on-line, the Remote Start/Stop input may be energized to start the compressor. When the input is de-energized, the compressor will stop but remain on-line. A failure or manual stop command will stop the compressor and force it off-line.

**NOTE:** *Before the remote location can control the system, the user must set the operating mode, and place the RECIP compressor on-line using the **RMT** hot key. Then, and only then, is the system ready to accept remote control signals.*

### Network Control

When the **NETWORK CONTROL** option is enabled, starting in the Remote or Auto-Remote mode is performed using messages from a remote computer. It is required that the compressor be placed on-line via the keypad or using an on-line message. For more information on Network Operation, please refer to Appendix C.

## Sequenced Start

In **SEQUENCED START**, the compressor takes commands from an Viltech Master Sequencer Control Panel. The Sequenced mode can be selected from the operating modes. Once this mode is selected the RECIP compressor must be placed on-line by using the **SEQ** hot key. Only when the RECIP compressor is placed on-line will the Viltech respond to control signals from the master sequencer.

## Sequenced in Remote Start

The VILTech panel can be controlled remotely and also be in sequence with other VILTech panels. In the Sequencer Setup screens, this option can be enabled in the Control screen by choosing "Automatic". Once this mode is selected the RECIP compressor must be placed on-line by using the **SEQ** hot key. Now all other panels in the sequence must be placed on-line by using the **SEQ** hot key otherwise the master panel will not be able to communicate to the slave panels.

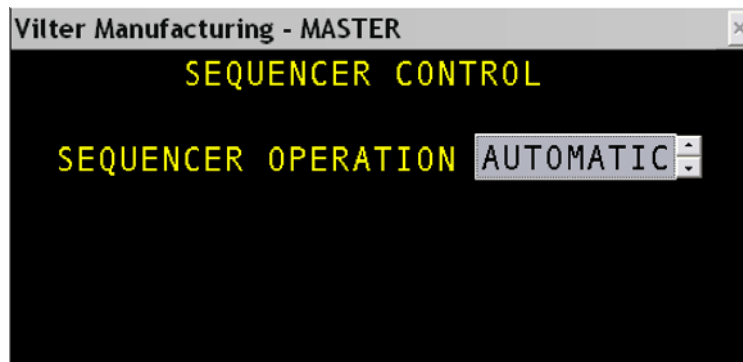

## Stopping the Compressor

The stopping sequence is as follows:

1. The Motor is stopped, the capacity stages are unloaded, and Cooling Control outputs are de-energized.
2. When the motor starter auxiliary contact opens within 15 seconds, the compressor will transition to the **STOPPED** state.
3. Once the compressor is stopped, oil temperature regulation may begin using the Oil Heater output and Oil Temperature input.

The RECIP compressor can be stopped manually or automatically depending on the operating mode. Any failure will automatically stop the compressor.

### Manual Stop

A **MANUAL STOP** is accomplished by using the stop button on the Viltech panel. The stop button is active on all screens and causes an immediate shutdown of the motor. Use of the manual Stop button will also take the compressor off-line.

### Automatic Stop

When the **AUTO START/STOP** feature is enabled and the compressor is in the Automatic mode, the compressor will stop automatically when the control parameter falls below the cut-out setpoint.

## Remote/Auto Remote Stop

### I/O Control

When remote operation is desired using discrete I/O signals, the Remote Start/Stop input signal is used to stop the compressor for the Auto-Remote mode. When the Remote Start/Stop input is de-energized, the compressor will stop but remain on-line. A failure or manual stop command will stop the compressor and force it off-line.

### Network Control

When the **NETWORK COMMUNICATIONS** option is enabled, stopping in the Remote and Auto-Remote modes is performed using messages from a remote computer. Separate messages are available to stop the compressor and leave it on-line, or to stop the compressor and force it off-line. For more information on network operation, please refer to Appendix C.

## Sequenced Stop

When the **STOP** command is received from the master sequencer, the Viltech will stop the RECIP compressor automatically and leave it on-line for sequenced operation. While stopped on-line, the compressor is available for sequencing and in standby waiting for commands.

## Capacity Control

**CAPACITY CONTROL** on a RECIP compressor is performed by adding or removing stages. Loading the compressor adds stages which increases the compressor capacity and Unloading the compressor removes stages which decreases the compressor capacity. A stage can consist of one or more Loaders which energize to add pistons, or Unloaders which de-energize to remove pistons. Capacity Control can be performed manually or automatically depending on the mode of operation.

**CAPACITY SETPOINTS** there is a Max Time at 0% capacity which is a timer that is intended to NOT allow the compressor to run too long at 0% capacity. The timer is activated in automatic and remote modes. If the compressor runs at 0% capacity longer than the allowed time then the compressor will perform a “Normal” stop and a log entry will be documented. When Auto Start/Stop is enabled then the compressor will restart when the suction pressure rises above the cut-in setpoint. The compressor may restart immediately, when two cases occur. Case #1- When the capacity ramp start delay is programmed lengthy and a low max time is at 0% capacity, it is possible that the Max 0% capacity timer will expire before the capacity ramp allows the machine to load. If, the suction pressure is above the cut-in setpoint and auto start/stop is enabled, compressor will restart immediately. Case #2- When the suction pressure is above cut-in and discharge pressure is above the limit/unload may be holding the compressor at 0% capacity so the 0% capacity timer will expire and the compressor will restart immediately.

## Manual Capacity Control

In **MANUAL** mode, the capacity is adjusted using the keypad on the Viltech. The up-arrow is used to add stages and the down-arrow is used to remove stages. Each time an arrow key is hit, one stage is added or removed until the compressor is fully loaded or unloaded. Manual capacity control can only be performed when viewing the Main Status screen.

## Automatic Capacity Control

**AUTOMATIC CAPACITY CONTROL** is accomplished by adding or removing stages to load and unload the compressor in response to changes in the control parameter (suction pressure or process temperature). Capacity changes are achieved using a time proportional control strategy with setpoints for Control Deadband, Normal Bandwidth, Normal Stage Delay, and Fast Stage Delay. Separate setpoints are provided for loading and unloading the compressor so that the operator may tune the system differently for increasing or decreasing load conditions.

The operator can also define up to four Control Groups which consist of Cut-In, Cut-Out, Control, Low Alarm, and Low Failure setpoints. The active control group can either be selected manually by using the active group screen or automatically through setpoint scheduling. The operator can also define a minimum capacity value which is used to limit capacity changes at the lower limit.

## **Control Groups**

Four groups of control setpoints can be defined for use with automatic capacity control. Each setpoint group consist of a Cut-In, Cut-Out, Control, Low Alarm, and Low Failure setpoint.

**Cut-Out Setpoint** -The Viltech will stop the compressor when the suction pressure or process temperature goes below the cut-out setpoint.

**Cut-In Setpoint** - The Viltech will start the compressor when the suction pressure or process temperature goes above the cut-in setpoint.

**Control Setpoint** -The Viltech will change the capacity in an attempt to maintain the suction pressure or process temperature at the control setpoint.

**Low Alarm/Failure Setpoints** -These are the low suction pressure or process temperature alarm and failure values associated with the control setpoint. In Sequenced Mode, the local setpoints are replaced by the Sequencer low alarm and failure set-points transmitted by the master sequencer controller.

## **Time Proportional Control Strategy**

For automatic capacity control, the amount of time between stage changes is a function of how far the Control Parameter is from the Control Setpoint and how long the Control Parameter remains outside the Control Deadband. A separate set of control parameters is defined for increasing or decreasing load conditions.

**Control Deadband** - When the difference between the Control Setpoint and the Control Parameter is less than the deadband value capacity changes will take place. If the Control Deadband values are too small, the capacity may increase and decrease excessively causing fluctuations in the Control Parameter. If the Control Deadband are too large, the compressor may not hold the Control Parameter close enough to the Control Setpoint resulting in inefficient capacity control.

**Normal Bandwidth** - If the difference between the Control Setpoint and the Control Parameter is between the Control Deadband value and the Normal Bandwidth value, the Normal Stage Delay timer will be used to determine when a stage will be added or removed.

If the difference between the Control Setpoint and the Control Parameter is greater than the Normal Bandwidth value, the Fast Stage Delay timer will be used to determine when a stage will be added or removed. This ensures that capacity changes will occur more quickly when the Control Parameter is far from the Control Setpoint.

If the Normal Bandwidth values are too small, the compressor will respond too quickly to small load changes and may constantly overshoot the optimal position. If the Normal Bandwidth values are too large, the compressor will react too slowly to load changes.

**Normal Stage Delay** - This is the amount of time used between stage changes when the Control Parameter is between the Control Deadband and the Normal Bandwidth. This value should be greater than the Fast Stage Delay time. If the Normal Stage Delay time is too small, then capacity changes will occur too often, possibly not allowing the affects of the previous change to take effect.

**Fast Stage Delay** - This is the amount of time used between stage changes when the Control Parameter is outside the Normal Bandwidth. This value should be less than the Normal Stage Delay time. If the Fast Stage Delay time is too large, then capacity changes will not occur often enough, possibly allowing the system to exceed safe limits.

The relationship of these parameters can be seen in the time proportional control strategy diagrams shown below:

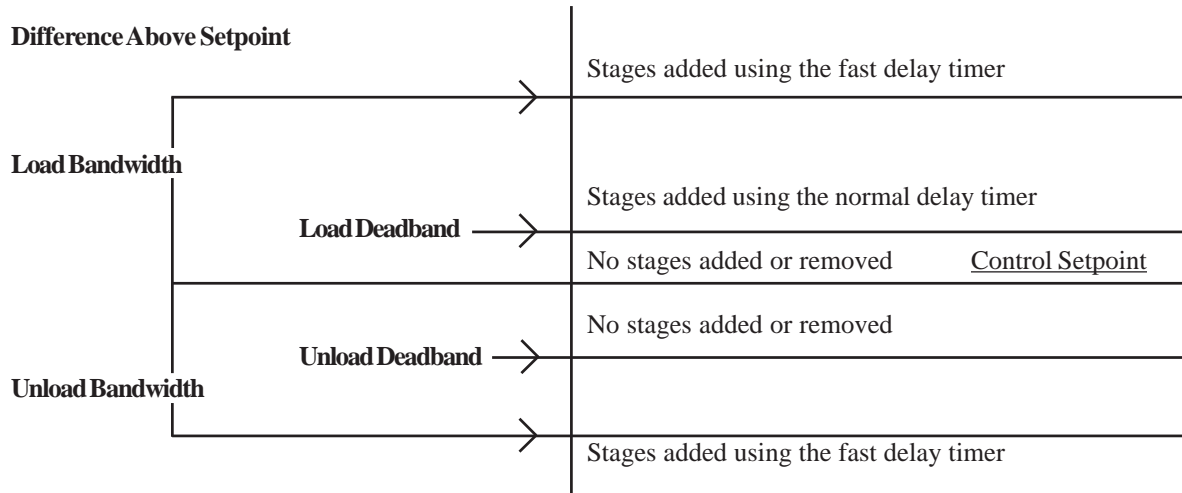

**Difference Below Setpoint**

### Stage Control Safety

### Remote Capacity Control

When the Network Communications option is enabled, and the compressor is in the Remote mode, capacity control is performed using load and unload messages from a remote computer. For more information on network operation, please refer to *Appendix C*.

### Auto-Remote Capacity Control

When the Network Communications option is enabled, and the compressor is in the Auto-Remote mode, capacity control is performed using **AUTOMATIC CAPACITY CONTROL**. The control setpoint is selected using setpoint messages from a remote computer.

## Sequenced Capacity Control

While in the **SEQUENCED** mode, Automatic Capacity Control is used to adjust the capacity as documented above. This is also true for **Sequenced mode in Remote control**. The master panel will wait for a remote indication to start and according to the parameter setpoints in the sequencer setpoints screen then the master will turn on and off the slave panels. If the master panel receives a remote indication to stop then the master panel will sequentially communicate to the other panels to unload and all the panels will stay on-line.

When a sequenced compressor is on-line, one of the following three commands will be sent from the master sequencer controller.

- **Trim** When the trim command is sent from the master sequencer, the Viltech will start the RECIP compressor. The Control Parameter and Control Setpoint will be also be sent from the master, and the compressor will begin making capacity adjustments using Automatic Capacity Control. Once the compressor is started, the status area will display RUN-TRIM indicating that the trim command was received.
- **Full Load** When the Full Load command is sent from the Master Sequencer, the Viltech will force and hold the compression at full capacity. When the Full Load command has been received the status area will display FULL LOAD.
- **Seq-Stop** When the Seq Stop command is received from the master sequencer the Viltech will stop the RECIP compressor automatically and leave it on-line for sequenced operation.

### Low Alarm and Failure Setpoints

When Sequenced mode is enabled and the compressor is online or running, the local low alarm and failure setpoints are replaced by the Sequencer low alarm and failure setpoints. This is true for both Suction Pressure and Process Temperature operation. The local sensor is still used to generate the alarm or failure condition.

### Running in Trim Mode

When the **TRIM** command is sent from the master sequencer the Viltech receives the System Control Parameter, System Control Setpoint, and the sequencer load and unload deadband and bandwidth parameters. These new control parameters are used instead of those defined on the Viltech itself. The compressor's local Normal Stage delay and Fast Stage delay are used for capacity changes.

The main status page will identify the control setpoint group as SY indicating that it is the System Control Setpoint. Automatic Capacity Control is used to adjust the capacity while in Sequenced mode. The System Control Parameter, System Control set-points, and Low Alarm and Failure setpoints are sent to the compressor periodically by the master sequencer to ensure that the compressor is always using current data. All automatic starting and stopping of the RECIP compressor is controlled by the master sequencer. The local RECIP's Cut-In and Cut-Out controls are also disabled. When the RECIP compressor is fully loaded, limited, or forced to unload due to high process temp or suction pressure, the VILTech informs the master sequencer that no further capacity increases are possible and additional compressors may be needed.

## **Running in Full Load Mode**

When the **FULL LOAD** command is received the Viltech disables all capacity control and locks the compressor at the fully loaded position. However, normal limiting and unloading functions will still be active.

## **Anti-Cycle in Sequenced Mode**

While in the **SEQUENCED** mode the anti-cycle time takes on a new role. If the master sequencer requests a RECIP compressor to stop but time is still remaining on the anti-cycle timer, the compressor will not stop. The compressor will remain running, until the anti-cycle timer expires. This procedure ensures that the compressor is always available for the next sequenced start. If the compressor should be stopped manually, or due to a failure, with time remaining on the anti-cycle timer it would then be unavailable for sequencing until the timer expires.

## **Forced Unloading & Limiting**

**FORCED UNLOADING AND LIMITING** are performed to protect the system under extreme conditions or to slow-down the rate of capacity increase. The Viltech may unload the compressor or limit loading of the compressor due to high discharge and suction pressure. In the Manual mode of operation and forced unloading is enabled. Forced Unloading and Limiting will cancel any ongoing capacity control changes. If a parameter exceeds the high limit setpoint the compressor will be limited (not allowed to load). If a parameter exceeds the high unload setpoint the compressor will be forced to unload until the parameter is reduced.

## **Ramp Start**

**RAMP START** adjusts the forced unloading and limiting setpoints during a period of time after the compressor is started. Ramp start is used to reduce the demand power requirements during compressor startup. Each high unload and high limit setpoint has associated with it a similar ramp unload and ramp limit setpoint. Also associated with each different parameter is a ramp duration time. After the compressor has started, the forced unloading and limiting setpoints are gradually changed from the ramp setpoints to the high setpoints during the ramp duration time. The Discharge Pressure Ramp Start parameters are set-up on the Discharge Pressure Setpoints screen under the **SETPT** hot key.

The relationship of the ramp start feature to unloading and limiting can be seen in the following figure.

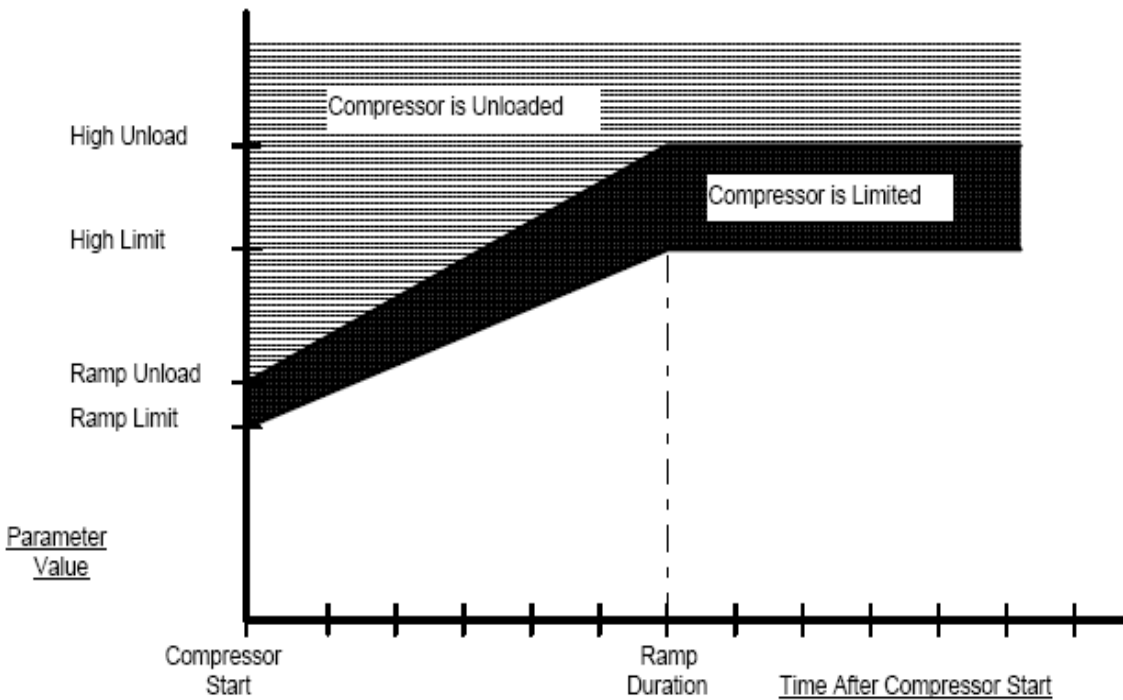

**Ramp Figure**

## Capacity Ramp Start Limiting

The **CAPACITY RAMP START** feature has been provided to limit capacity increases after the compressor starts. The operator can define the total time to limit capacity increases from the minimum capacity to 100% capacity. Once the compressor has started and the minimum capacity has been achieved, the capacity ramp timer is started, and further capacity increases will be limited. The maximum allowable capacity will be gradually increased from the minimum capacity to 100% over the ramp duration. When the capacity is limited due to this feature, the RECIP state will display “**LIMIT:CAP**”. Unlike other limiting and unloading, the compressor is not considered fully loaded when in this state.

The Capacity Ramp Start feature is available in Automatic, Auto-Remote and Sequenced mode. When in Sequenced mode, capacity changes are limited when the compressor is a Fully Loaded machine. If a fully loaded compressor is forced to unload for any reason, the capacity ramp will engage from the current capacity position once the limiting condition has gone away. The Capacity Ramp Start parameters are set-up on the Capacity set-point screen.



## Staging Setup

The Viltech controller can be configured to operate on any compressor that performs capacity control in discrete steps. The Controller supports up to six (6) capacity steps. Each capacity step is configured to energize to unload (Unloader). Also, each capacity step can be assigned a percentage associated with that level of capacity. A capacity percentage is also assigned to the fully unloaded position. The staging configuration is accessed from the configuration menu (**MENU > SYSTEM SETUP -> CONFIGURE HARDWARE -> STAGING CONFIGURATION**). To avoid possible damage to the compressor, it is important that the capacity configuration be setup to match the compressor configuration when the controller is initially installed.

## Minimum Capacity

Certain compressors should not operate below a minimum capacity value under normal operations. The compressor starts fully unloaded and then must be staged up to the minimum immediately. Once the compressor has started and the “Up to Speed” delay has expired, the compressor will be staged up to the minimum capacity position using the load fast stage delay. Once the minimum capacity has been reached, the compressor will transition into the running state. Under normal capacity control, the compressor will never unload beyond this value. Please check the compressor manufactures documentation to verify if this is required for your unit.

## Setpoint Scheduling

**SETPOINT SCHEDULING** is the automatic switching of Suction Pressure or Process Temperature control setpoint groups based on time of the day and day of the week. The operator can define up to seven (7) different daily time schedules and one weekly schedule. Schedule events can be manually overridden and scheduling can be enabled or disabled by the operator. Setup of schedules and control of the scheduling is performed from the Scheduling menu under the **SETPT** hot key.

### Daily Schedules

Each **DAILY SCHEDULE** consists of up to eight (8) different time-of-day slots. For each time-of-day slot the operator can define the time (either in 12 or 24 hour mode, depending on system clock mode selected) and the desired setpoint group number. Unused time slots are ignored and the schedule may be entered in any order. When the schedule is saved it is reordered chronologically. Each daily schedule is identified by a schedule name (SCH1 - SCH7).

### Weekly Schedule

The **WEEKLY SCHEDULE** allows the operator to assign different daily schedules to each day of the week. A new day begins and schedules change at midnight. The current daily schedule or control group may be overridden by the operator at anytime. Any item which has been manually overridden will be changed when the next schedule change occurs.

## Oil Pressure Computation

The oil pressure for a RECIP compressor is computed as follows:

Oil Pressure = Oil Pressure Sensor - Suction Pressure

The actual sensor value can be viewed on the Calibration and View analog screens. All other screens display the computed value.

## Oil Temperature Regulation

The **OIL TEMPERATURE** in the crankcase is regulated when the RECIP compressor is stopped. The temperature is maintained above the oil heater setpoint with a deadband of +5 degrees. When the compressor is stopped, and the Oil Temperature falls below the Heater Control Setpoint, the Oil Heaters will be turned on. When the Oil Temperature rises 5 degrees above the Heater Control setpoint, the oil heaters will be turned off. The Heater Control Set-point may be found on the Oil Temperature Setpoints screen under the **SETPT** hot key.

## Anti-Cycle Timer

The **ANTI-CYCLE TIMER** is used to avoid repeated start attempts within a user programmable period of time. The Anti-Cycle timer is started with the motor and must completely count down before the motor can be started again. The duration of the Anti-Cycle timer can be adjusted from the Miscellaneous Controls.

## Power Fail Restart

The operator can define a **POWER FAIL RESTART** time from the miscellaneous controls screen. If the **Viltech** is reset manually or due to a loss of power the down time is calculated and compared to this setpoint. If power was off longer than the power fail restart time a failure is reported. If the power loss was less than the setpoint no failure is reported and the compressor remains on-line and is allowed to automatically restart if required.

## Process Temperature Control (Option)

When the **PROCESS TEMPERATURE** option is enabled, the **RECIP** compressor capacity is adjusted to maintain the outlet temperature of a product or process instead of suction pressure (e.g. chiller outlet temperature control). The control strategy is documented in the Capacity Control section above.

## Two Stage Configuration (Option)

In a **TWO STAGE CONFIGURATION**, an intermediate pressure and temperature sensor are monitored. High Failure, High Alarm, Low Alarm and Low Failure setpoints are provided for each.

## Operational Procedures

The operator interface for the RECIP compressor is performed using LCD, keypad, and the following four hot keys:

STOP  
SETPT  
LOGS  
MENU

The following sections will explain the operating procedures associated with each of these hot keys.



**Momentary Screen**

The following table lists possible momentary screens associated with the START mode key function.

SCREEN	FUNCTION
<b>STARTING MANUAL MODE</b>	The compressor is starting in the Manual mode.
<b>STARTING AUTOMATIC MODE</b>	The compressor is starting in the Automatic mode.
<b>ON-LINE REMOTE MODE</b>	The compressor is on-line in the Remote mode and may be started by the remote computer.
<b>ON-LINE AUTO-REMOTE MODE</b>	The compressor is on-line in the Auto-Remote mode and may start, depending on the state of the Remote Start/Stop input, or the remote computer.
<b>ON-LINE SEQUENCED MODE</b>	The compressor is on-line in the Sequenced mode and may start, depending on the master sequencer.
<b>START DISABLED ALREADY IN PROGRESS</b>	The start function is disabled because the compressor is already in the process of undergoing the start-up operation.
<b>START DISABLED SYSTEM RUNNING</b>	The start function is disabled because the compressor is already IS running.
<b>START DISABLED ANTI-CYCLE XX:XX</b>	The compressor is delayed from starting. An anti-cycle timer has been activated which prevents start-up until the time period has expired (XX:XX is the time remaining). The screen will continue to be displayed until the timer expires or the user presses the QUIT key.
<b>START DISABLED SYSTEM ALARM/FAILURE</b>	The start function is disabled due to a system alarm or ALARM/ failure.



## Status Screens

The status of the compressor can be viewed from a group of status screens as described below. Consecutive uses of the **QUIT** key will return the user to the main **STATUS SCREEN**.

### Compressor Main Status Screen

The **COMPRESSOR STATUS SCREEN** shows a numerical summary of the compressor analog and state parameters. The values are continuously updated in real-time to reflect the current state of the compressor. For example, in the figure below, the current state of the system is **STOP-ONLINE**. The system's mode of operation is **SEQ** (Sequenced) and the alarm status of the system is **NORM** (normal). There are also two system functions which may be performed from this screen: Capacity adjustment when in Manual mode and the clearing of alarms and failures.

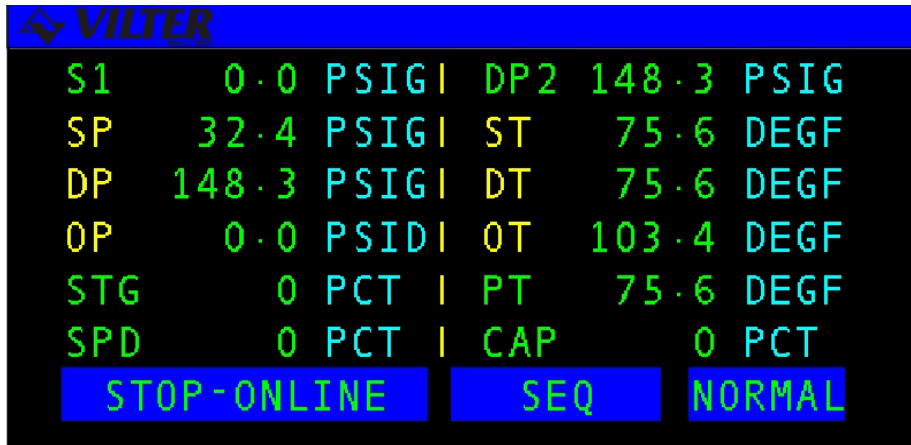

### RECIP Status Screens

The following table lists the additional keys available on the RECIP status screen.

KEY	FUNCTION
UPARROW	Loads the compressor when RECIP is in Manual or Local mode. One stage is added each time the UP arrow key is pressed.
DOWNARROW	Unloads the compressor when RECIP is in Manual or Local mode, or if one stage is removed.
CLEAR	Stops manual capacity loading or unloading. Acknowledges alarms and failures and stops the alarm horn from sounding.

### RECIP Status Screen Keys

Manual Capacity changes are discussed in the *Capacity Control* section and Alarms and Failures are discussed in the Alarm/Failure section of this manual.

The following table lists the various parameters displayed on the RECIP status screen.

<b>PARAMETER</b>	<b>DESCRIPTION</b>
<b>S1-S4, P1-P4, SY</b>	The active capacity control setpoint. S1-S4 indicate represent Suction Pressure setpoints, P1-P4 represent Process Temperature setpoints, and SY represents the Sequenced setpoint.
<b>SP</b>	Suction Pressure
<b>DP</b>	Discharge Pressure
<b>OP</b>	Oil Pressure
<b>IP</b>	Intermediate Pressure (two-stage machines only)
<b>CP</b>	Capacity
<b>ST</b>	Suction Temperature
<b>DT</b>	Discharge Temperature
<b>OT</b>	Oil Temperature

### **Status Banner**

The **STATUS BANNER** is located at the bottom of the Compressor status screen, Active Alarms & Failures screen, and Auto-Start Warning status screen. The Banner consists of three highlighted sections which provide the user with the status of the following system conditions.

- Current System State
- Current Operating mode
- Alarm & Failure Status

## Current System State

The left-most highlighted status banner section displays the **CURRENT STATE** of the system. The following is a table with a brief description of possible system states.

<b>CURRENT STATE</b>	<b>DESCRIPTION</b>
<b>ACYCLE XX:XX</b>	Anti-cycle count down timer has been activated to delay motor start. XX:XX is the time remaining.
<b>STOPPED</b>	Compressor is stopped.
<b>STARTING</b>	Starting sequence is in progress.
<b>RUNNING</b>	Compressor is running.
<b>INCREASING</b>	Capacity is increasing.
<b>DECREASING</b>	Capacity is decreasing.
<b>LIMIT:CAP</b>	Loading was stopped due to capacity
<b>LIMIT:DP</b>	Loading was stopped due to high discharge pressure.
<b>UNLOAD:DP</b>	Forced unloading due to high discharge pressure.
<b>STOPPING</b>	Stopping sequence is in progress.
<b>FAILED</b>	Compressor has failed.
<b>RESET</b>	The Viltech has been reset.
<b>STOP-OFFLINE</b>	Compressor is stopped and is off-line (not available for auto start).
<b>STOP-ONLINE</b>	Compressor is stopped and is on-line (available for auto start)
<b>STOP CUT-OUT</b>	Compressor is stopped on cut-out pressure (or temperature)
<b>RUN-TRIM</b>	The compressor is running in Sequenced mode as the Trim machine.
<b>FULL-LOAD</b>	The compressor is running in Sequenced mode as a Fully Loaded machine.

## System State

### Mode Area

The middle highlighted status banner section displays the general operating mode of the system as shown in the following table:

<b>MODE</b>	<b>DESCRIPTION</b>
<b>AUTO</b>	Automatic mode is selected.
<b>MAN</b>	Manual mode is selected.
<b>RMT</b>	Remote mode is selected.
<b>SEQ</b>	Sequenced mode is selected.

## System Modes



## Alarm & Failure Area

The right most highlighted status banner section displays the ALARM AND FAILURE STATUS of the system. When a new alarm or failure occurs, this area will flash from highlighted to non-highlighted to inform the operator. The area will stop flashing but remain highlighted when the operator has used the CLEAR key to acknowledge the alarm or failure. Once all alarm and failure conditions have been corrected the operator may again press the CLEAR key to clear the alarm from the display. The following table lists the various alarm/failure states and their meanings.

*NOTE: If both an alarm and failure exist the failure state will be displayed as it has a higher priority*

ALARM MESSAGE	SYSTEMS STATUS
NORM	No alarm or failure is active, the RECIP is operating normally.
ALARM	An alarm is active on the RECIP.
FAIL	A failure is active on the RECIP.

## Operating Hours Screen Alarm Status

The OPERATING HOURS STATUS screen allows the operator to view the compressor's current running hours since its last start and the total number of hours the system has been in operation since installation. In addition, the number of compressor starts is accumulated for today, yesterday, and the overall total.

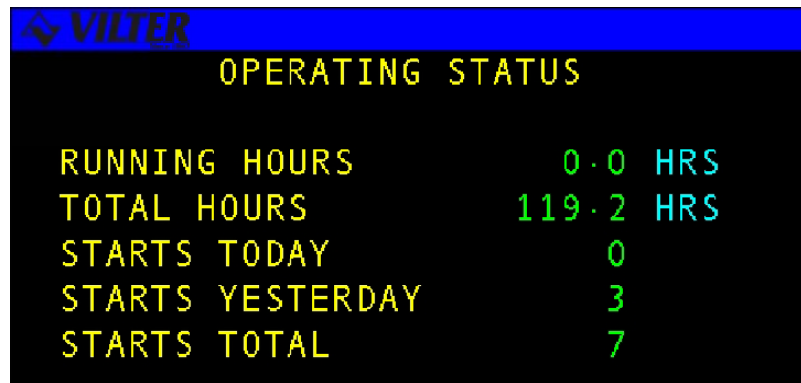

VILTER OPERATING STATUS	
RUNNING HOURS	0.0 HRS
TOTAL HOURS	119.2 HRS
STARTS TODAY	0
STARTS YESTERDAY	3
STARTS TOTAL	7

**Operating Hours Status Screen**

The following table lists the various parameters displayed on the screen.

TERM	DEFINITION
RUNNING HOURS	The number of successive motor running hours since the last start up.
TOTAL HRS	The motor's total accumulated running hours.
STARTS TODAY	The number of times the motor has been started since midnight.
STARTS YESTERDAY	The number of times the motor was started yesterday.
STARTS TOTAL	The total number of times the motor has been started.

**Operating Hours Status Definitions**

## Active Alarms & Failures Status Screen

The **ACTIVE ALARMS & FAILURES STATUS** screen displays the system's current Alarms/Failures. This screen will be the initial screen displayed by the system when an alarm or failure first becomes active. The default status screen can be reached by simply pressing the **QUIT** key. An example of the alarm screen is shown below.

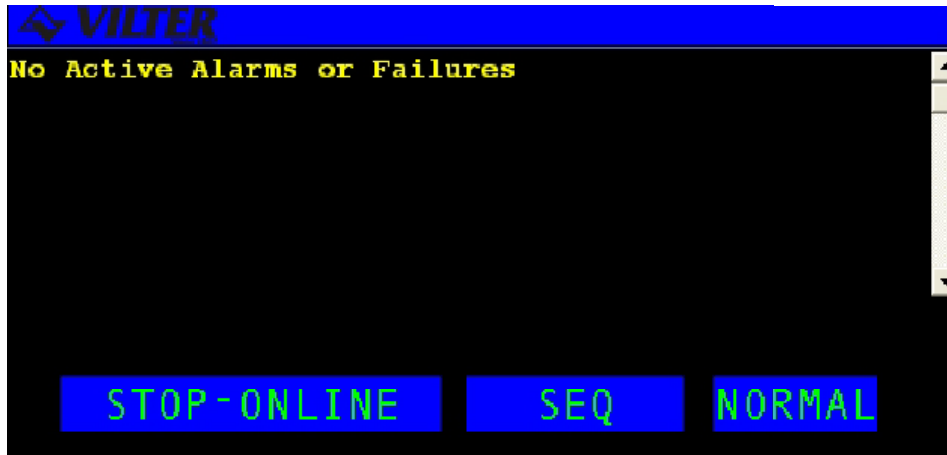

**Active Alarms & Failures Status Screen**

The active function keys for this screen are described in the following table.

KEY	FUNCTION
SHIFT UP/ DOWNARROWS	Switches control between the display area and the hot keys. Scrolls line by line through the information.
CLEAR	The CLEAR key is used to acknowledge and clear alarms/failures as well as to silence the alarm horn.

**Active Alarms & Failures Status Screen Definitions**

## Auto-Start Warning Screen

The **AUTO-START WARNING** screen is displayed anytime the RECIP may be automatically started. The user can return to the system default status screen by pressing the **QUIT** key or cycle through all the status screens using the **ENTER** key. The system will return to the Auto-Start Warning screen after 10 minutes of keypad inactivity. An example of the screen is shown below.



**AUTO Start Warning Screen**

## SETPT Hot Key

The **SETPT** hot key allows the operator to select various systems options available. When the **SETPT** key is selected, a menu screen displays the available options contained on the system.

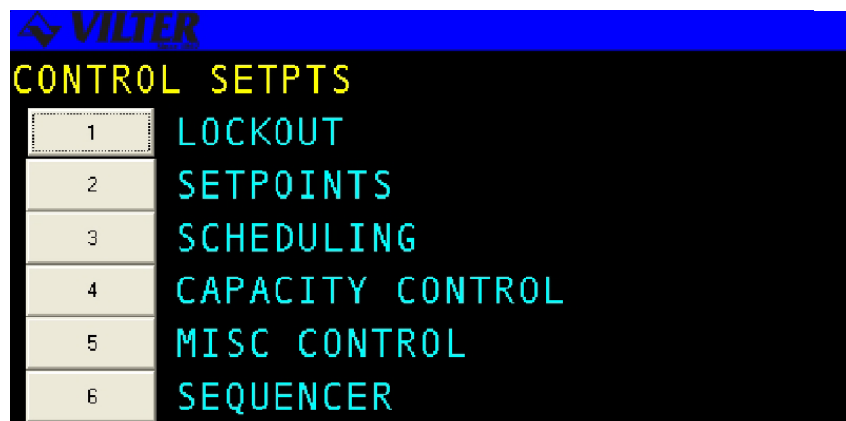

**SETPT Hot Key Screen**

## Setpoint

The **SETPOINT** option allows the user to access a set of menu options used to set the systems various setpoints. SETPOINTS

### 1. PRESSURE

1. SUCTION CONTROL GROUP
2. HIGH SUCTION
3. DISCHARGE
4. OIL
5. INTERMEDIATE (Two stage only)

### 2. TEMPERATURE

1. DISCHARGE
2. OIL
3. PROCESS GRP
4. HIGH PROCESS
5. INTERMEDIATE (Two stage only)

### 3. CAPACITY

### SETPT Menu Diagram

## Pressure Setpoints

The Pressure Setpoints menu allows the user adjust the various pressure related setpoints described in the following sections.

## Suction Pressure Control Groups

This screen allows the user to set the control values for each of the RECIP's four (4) control groups which are used for Automatic Capacity control. An example of the screen is shown below.

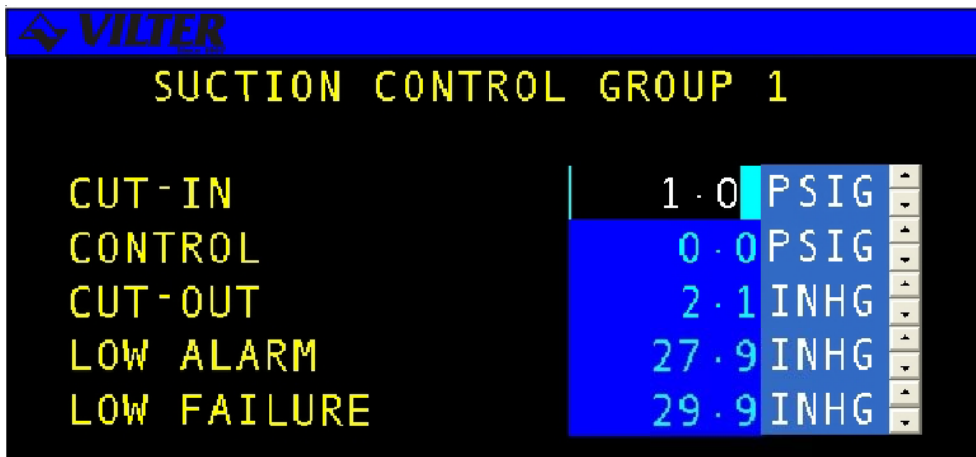

Suction Pressure Control Data Entry Screen

The following table lists the data entry fields on the screen and a description of their purposes.

TERM	DEFINITION	RANGE
CUT-IN	Cut-in Setpoint. If Automatic or Auto-Remote mode is selected, Auto Start/Stop is enabled, the compressor is on-line, and the suction pressure rises above the Cut-in Setpoint, the compressor will start.	29.9 INHG 185.0 PSIG
CONTROL	Control Setpoint. In the Automatic or Auto-Remote mode of operation the compressor is loaded or unloaded as required to maintain the Control Set-point.	29.9 INHG 185.0 PSIG
CUT-OUT	Cut-out Setpoint. If Automatic or Auto-Remote mode is selected, Auto Start/Stop is enabled, the compressor is running, and the suction pressure falls below the Cut-out Setpoint, the compressor will stop.	29.9 INHG 185.0 PSIG
LOWALARM	The Suction Pressure value at which the <b>Viltech</b> should report a Low Suction Pressure alarm to the operator (for all modes except Sequenced).	29.9 INHG 185.0 PSIG
LOWFAILURE	The Suction Pressure value at which the <b>Viltech</b> should fail (stop) the compressor and report a failure to the operator (for all modes except Sequenced).	29.9 INHG 185.0 PSIG

**Suction Pressure Control Data Definitions**

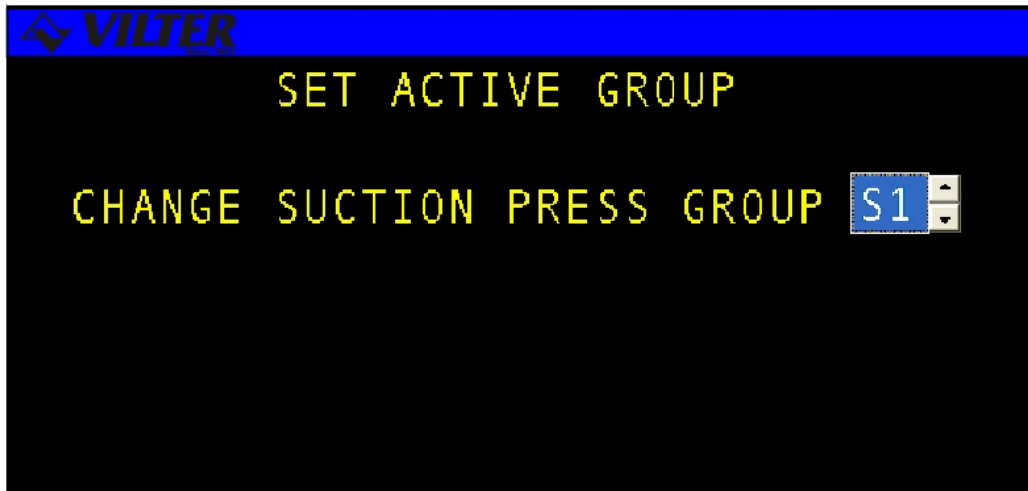

**Suction Pressure Active Group Control Screen**

TERM	DEFINITION	RANGE
ACTIVEGROUP	There are four possible suction pressure control groups, each with its own pressure parameters. This field is used to manually select the active setpoint group.	S1-S4

### Suction Pressure Active Group Control Definitions

### High Suction Pressure Setpoints

The **HIGH SUCTION PRESSURE** alarm and failure setpoints are not scheduled and are active regardless of which group is in control. This screen also has the High Suction Limit & Unloading for each step of CapacityControl



High Suction Pressure Setpoints Screen

The following table lists the data entry fields for the High Suction Pressure Set-points screen

TERM	DEFINITION	RANGE
HIGHFAILURE	The compressor is failed (stopped) when this value is exceeded.	29.9 INHG -185 PSIG
HIGHALARM	The Viltech reports an alarm to the operator when this value is exceeded.	29.9 INHG -185 PSIG

### High Suction Pressure Data Definitions

## Discharge Pressure Setpoints

The **DISCHARGE PRESSURE SETPOINTS** screen is used to set the discharge pressure control parameters for high alarm, limiting, and ramp conditions.



**Discharge Pressure Setpoints Data Entry Screen**

The following table lists the data entry fields for the Discharge Pressure Setpoints screen.

TERM	DEFINITION	RANGE
HIGH FAILURE	The compressor is failed (stopped) when this value is exceeded.	0 - 225 NH <sub>3</sub> O - 275 FREON
HIGH ALARM	The Viltech reports an alarm to the operator when this value is exceeded.	0 - 225 NH <sub>3</sub> O - 275 FREON
HIGH UNLOAD	The compressor is forced to unload when this value is exceeded.	0 - 225 NH <sub>3</sub> O - 275 FREON
HIGH LIMITING	The compressor is not allowed to load when this value is exceeded.	0 - 225 NH <sub>3</sub> O - 275 FREON
RAMP UNLOAD	The starting value of the forced unload parameter used during ramp start.	0 - 225 NH <sub>3</sub> O - 275 FREON
RAMP LIMITING	The starting value of the limiting parameter used during ramp start.	0 - 225 NH <sub>3</sub> O - 275 FREON
RAMP START DELAY	The time period after start used to ramp the forced unload and limiting parameters from the ramp value to the normal value.	0.1 - 60 Min
RAMP START ENABLE	Allows Discharge Pressure Ramp start to be enabled or disabled.	ENABLE/ DISABLE

**Discharge Pressure Data Definitions**



## Oil Pressure Setpoints

The **OIL PRESSURE SETPOINTS** screen allows the operator to set acceptable ranges for the oil pressure parameter to allow the Viltech to identify when the value is out of range. An example of the screen is shown below.

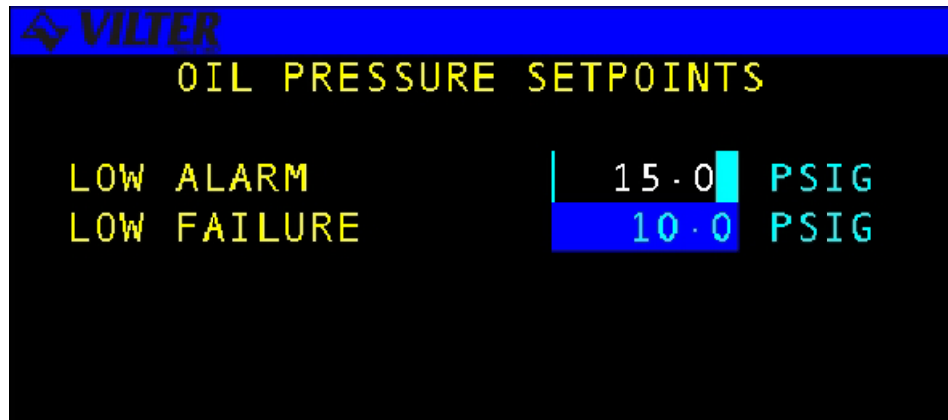

**Oil Pressure Setpoints Screen**

The following table lists the data entry fields and a description of their purpose.

<b>TERM</b>	<b>DEFINITION</b>	<b>RANGE</b>
<b>LOWALARM</b>	The Viltech will report an alarm to the operator when the Oil Pressure is below this value	20 - 200 PSIG
<b>LOWFAILURE</b>	The compressor will be failed (stopped) when the Oil Pressure is below this value.	20 - 200 PSIG

## Oil Pressure Setpoints Definitions

***NOTE:** The Oil Pressure on a RECIP Compressor is computed as the differential between the Oil Pressure Sensor and Suction Pressure.*

## Intermediate Pressure Setpoints (Two Stage only) Option

The **INTERMEDIATE PRESSURE SETPOINTS** screen allows the operator to set acceptable ranges for the intermediate pressure, and is only visible on the two stage compressor. An example of the screen is shown below.

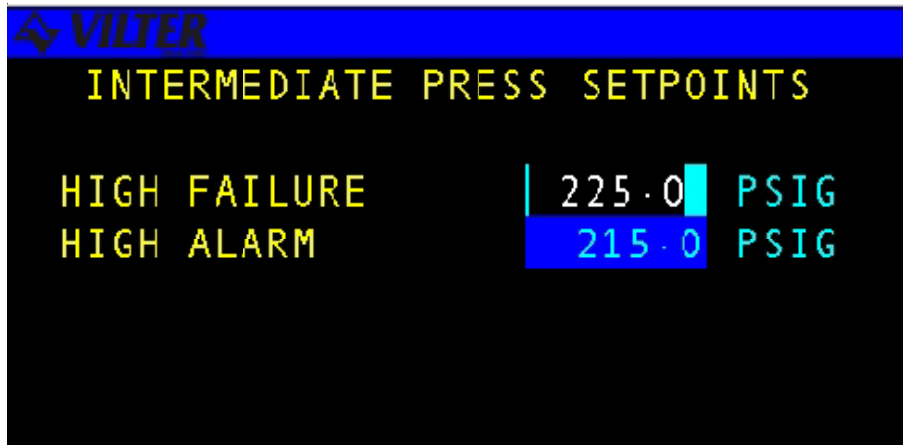

### Intermediate Pressure Setpoints

The following table lists the data entry fields and a description of their purposes.

TERM	DEFINITION	RANGE
HIGHFAILURE	The compressor is failed (stopped) when the Intermediate Pressure exceeds this value.	0 - 225 PSIG
HIGHALARM	The Viltech reports an alarm to the operator when the Intermediate Pressure exceeds this value.	0 - 225 PSIG
LOWALARM	The Viltech will report an alarm to the operator when the Intermediate Pressure is below this value.	0 - 225 PSIG
LOWFAILURE	The compressor will be failed (stopped) when the Intermediate Pressure is below this value.	0 - 225 PSIG

### Intermediate Pressure Definitions

## Temperature Setpoints

The **TEMPERATURE SETPOINTS** menu allows the user to set temperature related setpoints described in the following sections. *Discharge Temperature Setpoints*

### Discharge Temperature Setpoints

The **DISCHARGE TEMPERATURE SETPOINTS** screen allows the operator to set acceptable ranges for the RECIP discharge temperature and second discharge temperature (DT2) for 12 & 16 single stage compressors.

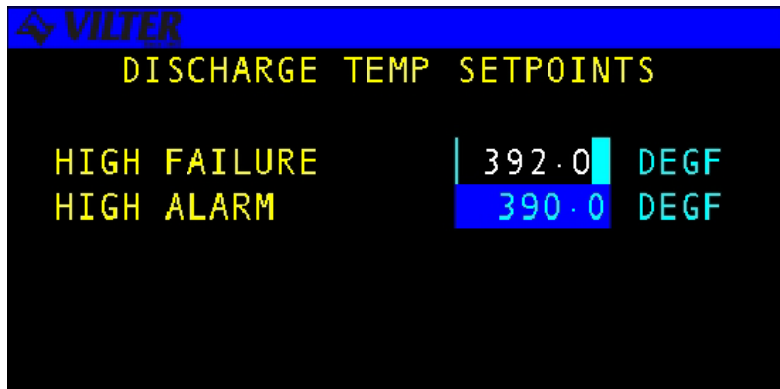

**Discharge Temperature Setpoints Screen**

The following table lists the data entry fields and a description of their purposes.

TERM	DEFINITION	RANGE
HIGH FAILURE	The compressor is failed (stopped) when the discharge temperature exceeds this value.	32 - 392 DEGF

**Discharge Temperature Definitions**

## Oil Temperature Setpoints

The **OIL TEMPERATURE SETPOINTS** screen allows the operator to set acceptable ranges for the RECIP oil temperature.

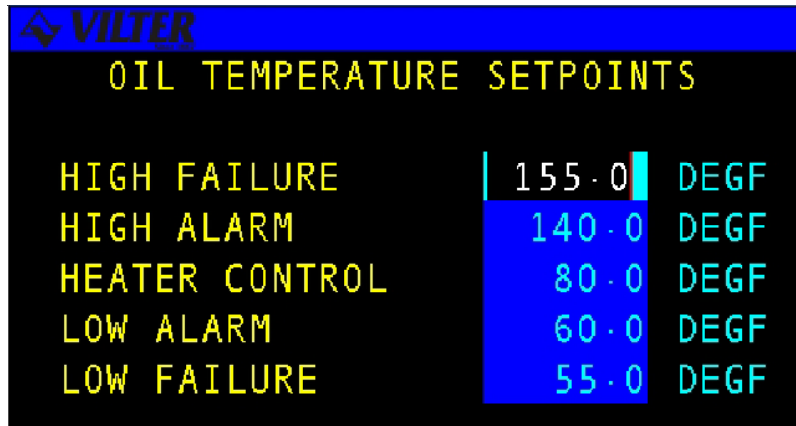

**Oil Temperature Setpoints Screen**

The following table lists the data entry fields and a description of their purposes.

TERM	DEFINITION	RANGE
<b>HIGHFAILURE</b>	The compressor will be failed (stopped) when the oil temperature exceeds this value.	32 - 392 DEGF
<b>HIGHALARM</b>	The Viltech will report an alarm to the operator when the oil temperature exceeds this value	32 - 392 DEGF
<b>HEATERCONTROL</b>	The temperature at which to maintain the oil in the separator. The oil heater uses the Oil Temperature sensor but only when the compressor is stopped.	32 - 392 DEGF
<b>LOWALARM</b>	The Viltech will report an alarm to the operator when the Oil Temperature is below this value.	32 - 392 DEGF
<b>LOWFAILURE</b>	The compressor will be failed (stopped) when the Oil Temperature is below this value.	32 - 392 DEGF

**Oil Temperature Definitions**

## Process Temperature Control Group

The **PROCESS TEMPERATURE CONTROL GROUP** screen is used to set-up the Process Temperature control parameters when the Process Temperature Control option is enabled.

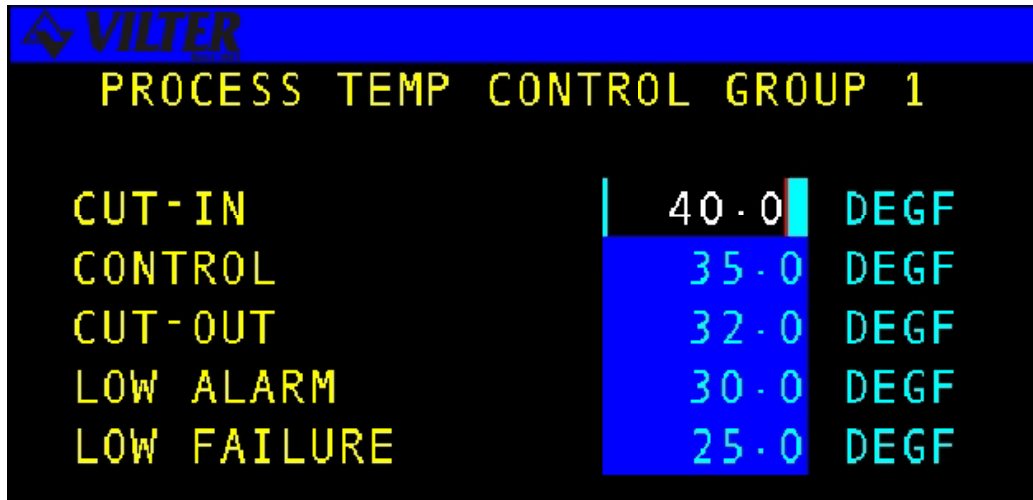

Process Temperature Control Group

TERM	DEFINITION	RANGE
<b>CUT-IN</b>	Cut-in Setpoint. If Automatic or Auto-Remote mode is selected, Auto Start/Stop is enabled, the compressor is on-line, and the process temperature rises above the Cut-in Setpoint, the compressor will start.	-58: 122 DEGF
<b>CONTROL</b>	Control Setpoint. In the Automatic or Auto-Remote mode of operation the compressor is loaded or unloaded as required to maintain the Control Set-point.	-58: 122 DEGF
<b>CUT-OUT</b>	Cut-out Setpoint. If Automatic or Auto-Remote mode is selected, Auto Start/Stop is enabled, the compressor is running, and the process temperature falls below the Cut-out Setpoint, the compressor will stop.	-58: 122 DEGF
<b>LOWALARM</b>	An alarm is reported when the Process Temperature falls below the low alarm setpoint.	-58: 122 DEGF
<b>LOWFAILURE</b>	A failure is reported and the compressor is shutdown when the Process\ Temperature falls below the low failure setpoint.	-58: 122 DEGF

Process Temperature Definitions

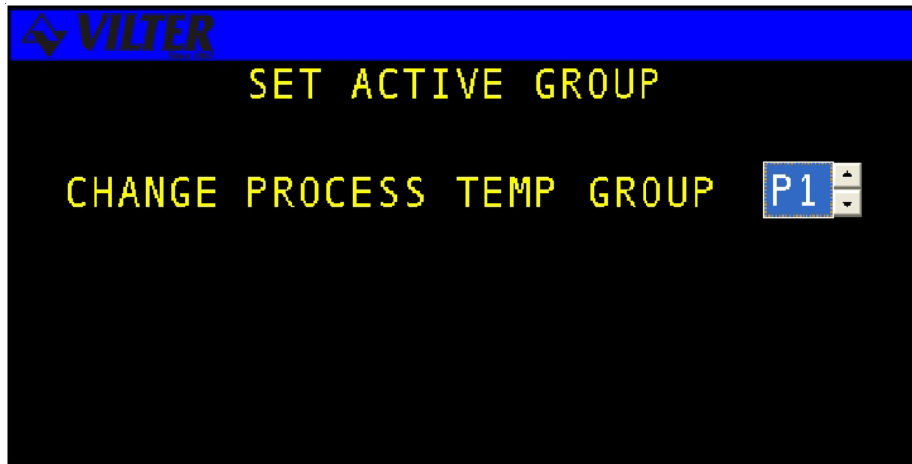

**Process Temperature Active Group Control Screen**

TERM	DEFINITION
ACTIVEGROUP	There are four possible process temperature control groups, each with it's own temperature control parameters. This field is used to manually select the active setpoints group.

**Process Temperature Active Group Control Definitions**

### High Process Temperature Setpoints

The HIGH PROCESS TEMPERATURE SETPOINTS screen is only visible when the Process Temperature Control option is enabled.

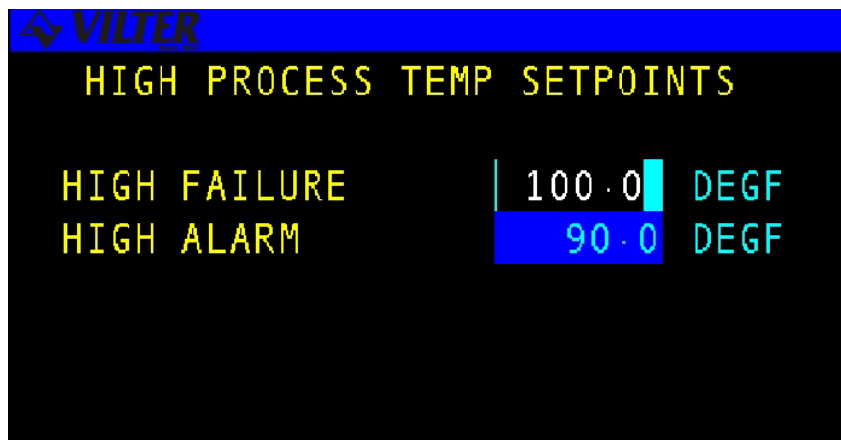

**High Process Temperature Setpoints Screen**

TERM	DEFINITION	RANGE
HIGHFAILURE	A failure is reported and the compressor is shutdown when the Process Temperature rises above the High Failure setpoint	-58: 122 DEGF
HIGHALARM	An alarm is reported when the Process Temperature rises above the High Alarm setpoint.	-58: 122 DEGF

**High Process Temperature Setpoint Definitions**

## Note Page

## Capacity Setpoints

The **CAPACITY SETPOINTS** screen allows the operator to set acceptable ranges for minimum Capacity and Ramp Start Parameters as shown in the following example.

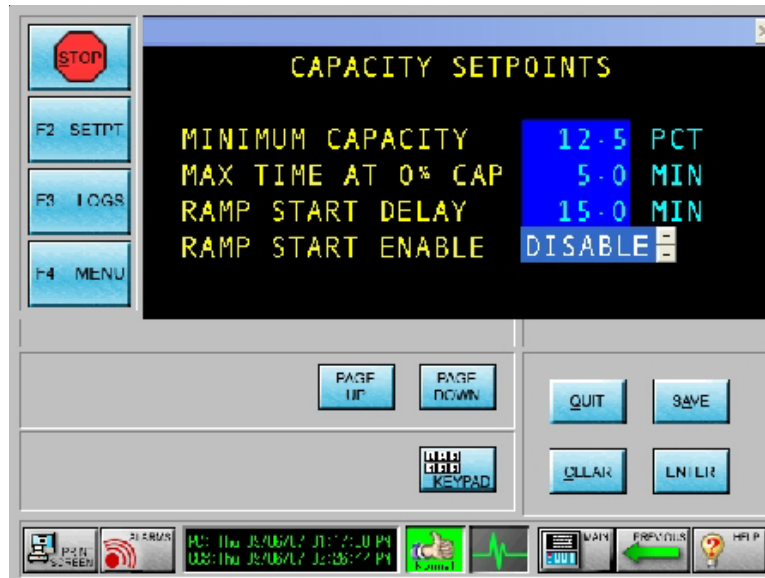

**Capacity Setpoint Screen**

The following table lists the data entry fields and a description of their purposes.

TERM	DEFINITION	RANGE
MINIMUMCAPACITY	The minimum allowable capacity of the compressor when running.	0 - 100 PCT
RAMPSTARTDELAY	The amount of time after startup that Capacity Limiting will take place.	0-60 MIN
RAMPSTARTENABLE	Allows Capacity Ramp Start to be enabled or disabled.	ENABLE/ DISABLE

**Capacity Setpoint Definitions**



## Scheduling

The **SCHEDULING** function allows the user to create and modify schedules to control the changing of Suction Pressure or Process Temperature Setpoints based on the day of the week and time of day. The following sections will describe the various screens associated with this function.

### Scheduling

1. CONTROL
2. ACTIVE GROUP
3. ACTIVE SCHED
4. WEEKLY SCHED
5. DAILY SCHED

### Control

The **CONTROL** screen allows the user to determine if equipment operation will be controlled by predefined schedules. An example of this screen is shown below.

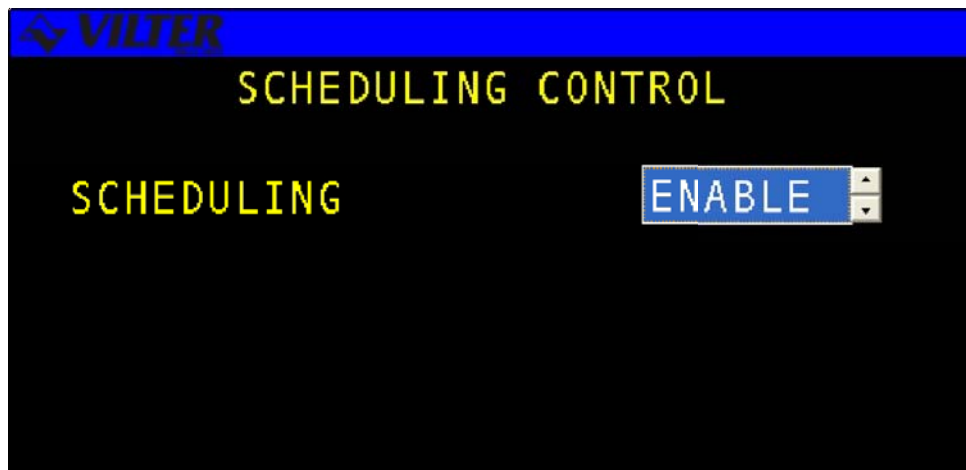

**Scheduling Control Screen**

The following table lists the data entry fields and a description of their purposes.

TERMS	DEFINITION	RANGE
SCHEDULING	Allows the Setpoint Scheduling feature to be enabled or disabled	ENABLED/DISABLE

**Scheduling Definition**

## Active Group

The **ACTIVE GROUP** screen allows the user to select the current active group. This setting will be active until a scheduling change or the operator modifies it. An example of the screen is shown below.

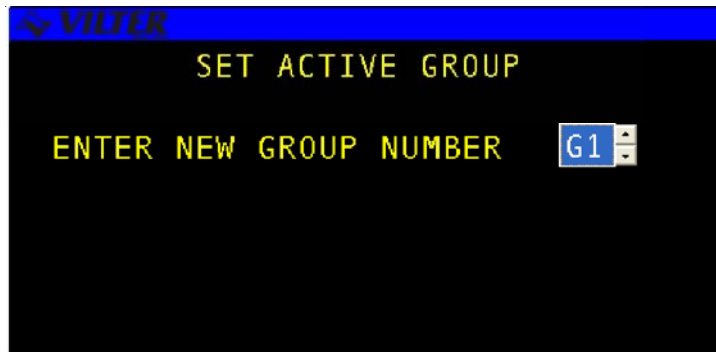

**Active Group Screen**

The following table lists the data entry fields and a description of their purposes.

TERM	DEFINITION	RANGE
GROUPNUMBER	The active suction pressure control group for the system. If Suction Pressure control is enabled, G1-G4 correspond to Suction Pressure control groups S1-S4. If Process Temperature control is enabled, G1-G4 correspond to Process Temperature control groups P1-P4.	G1-G4

**Active Group Definitions**

## Active Schedule

The **ACTIVE SCHEDULE** screen allows the user to change the current active daily schedule. This setting will be active until a scheduling change or the user modifies it. An example of the screen is shown below.

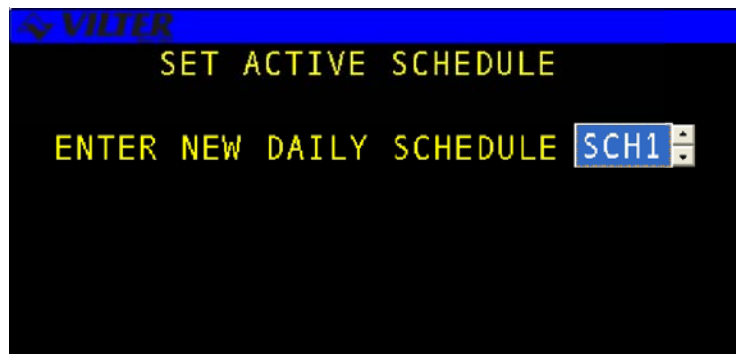

**Active Schedule Screen**

The following table lists the data entry fields and a description of their purposes.

TERM	DEFINITION	RANGE
DAILY SCHEDULE	The current daily schedule used by the system.	SCH1 - SCH7

**Active Schedule Definitions**

## Weekly Schedule

The **WEEKLY SCHEDULE** screen is used to define which of the seven available daily schedules is to be assigned to each day of the week as shown in the following example screen.

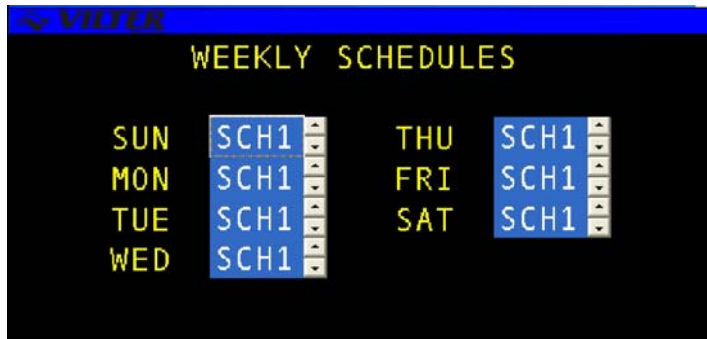

**Weekly Schedule Screen**

The following table lists the data entry fields and a description of their purposes.

TERM	DEFINITION	RANGE
DAYS OF THE WEEK	The daily schedule assigned to that specific day of the week.	SCH1 - SCH7

**Weekly Schedule Definitions**

## Daily Schedule

The **DAILY SCHEDULE** function is used to define the times at which to change control setpoints for each of the seven available daily schedules. The first screen upon entering the Daily Schedule function is an access screen, which prompts the user to enter a number from one to seven to view the corresponding Daily Schedule.

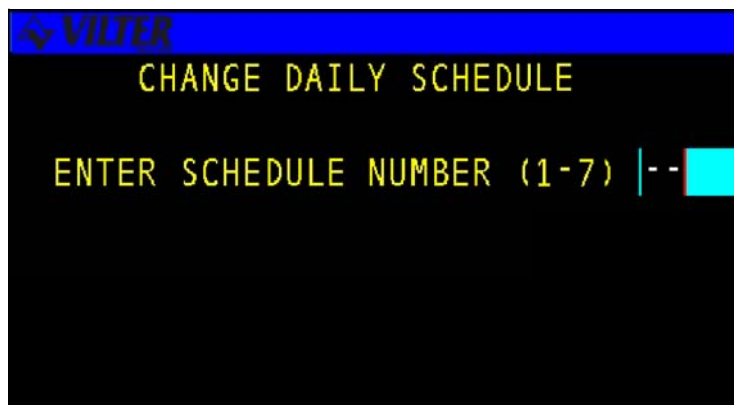

**Daily Schedule Screen**

*Schedule 1 To Schedule 7*

The seven **DAILY SCHEDULES** all have a standard format allowing the user to select up to 8 schedule changes per day. The following example shows the standard format for all seven of the daily schedules.

<b>DAILY SCHEDULE</b>		<b>hh:mm:ss</b>
<b>NUMBER</b>	<b>SCHED TIME</b>	<b>GROUP</b>
1	XX:XX AM	G1
2	XX:XX AM	G2
3	XX:XX AM	G3
4	XX:XX AM	G4
5	XX:XX AM	G3
6	XX:XX AM	G2
7	XX:XX AM	G1
8	XX:XX AM	G1

**Daily Schedule 1 Screen**

The following table lists the data entry fields and a description of their purposes.

<b>TERM</b>	<b>DEFINITION</b>	<b>RANGE</b>
<b>SCHED TIME</b>	The time of day the control group will be changed to the selected group.	Valid Time
<b>GROUPS</b>	The control group number to be used after the scheduled time occurs.	G1-G4

### Daily Schedule 1 Definitions

## CAP Control

The **CAP CONTROL** option allows the user to access a set of menu options used to set the systems control features. CAP CONTROL

### CAPCONTROL

1. SUCT PRESS
2. PROC TEMP

## Suction Pressure Control Setpoints

The **SUCTION PRESSURE CONTROL SETPOINTS** screen allows the user to set-up the Load and Unload Controls for Automatic capacity control. The Normal Stage delay and Fast Stage Delay fields are also used for Capacity changes in the Sequenced mode. Included on this screen is additional reference data to assist the operator when setting-up the compressor. An example of the screen is shown below.

SUCTION PRESS CONTROL SETPTS		hh:mm:ss		
		LOAD		UNLOAD
NORMAL BANDWIDTH		XX.X		XX.X PSID
CONTROL DEADBAND		XX.X		XX.X PSID
NORMAL STAGE DELAY		XX.X		XX.X SEC
FAST STAGE DELAY		XX.X		XX.X SEC
SETPOINT	S1	X.X PSIG	SP	XX.X INHG
MODE	AUTO		CP	XX.X PCT
STATE	FAILED			

**Suction Pressure Control Setpoints Screen**

The following table lists the data entry and information fields on the screen and a description of their purposes.

PARAMETER	DEFINITION	RANGE
<b>NORMAL BANDWIDTH</b>	Adjusts the sensitivity of the time proportional control routine.	0 - 20 PSID
<b>CONTROL DEADBAND</b>	The capacity will not be adjusted if the suction pressure is within the control deadband.	0- 20 PSID
<b>NORMAL STAGEDELAY</b>	The Normal Stage Delay Timer starts when the Suction Pressure exceeds the Control Deadband. When it expires, a stage will be added or removed as appropriate	1 - 999 SEC
<b>FAST STAGE DELAY</b>	The Fast Stage Delay Timer starts when the Suction Pressure exceeds the Normal Bandwidth.	1 - 999 SEC
<b>SETPOINT</b>	The current control setpoint group and value (reference).	N/A
<b>SUCTION PRESSURE</b>	The current suction pressure (reference).	N/A
<b>CAPACITY</b>	The current capacity (reference)	N/A
<b>RECIPMODE</b>	The current compressor mode (reference).	N/A
<b>RECIPSTATE</b>	The current compressor state (reference).	N/A

### Suction Pressure Control Setpoints Definitions

### Process Temperature Control Setpoints

The **PROCESS TEMPERATURE CONTROL SETPOINTS** screen allows the user to setup the Load and Unload Controls for Automatic capacity control. The Normal Stage delay and Fast Stage Delay fields are also used for Capacity changes in the Sequenced mode. Included on this screen is additional reference data to assist the operator when setting-up the compressor. An example of the screen is shown below.

PROCESS TEMP CONTROL SETPTS		hh:mm:ss	
	LOAD	UNLOAD	
NORMAL BANDWIDTH	XX.X	XX.X	DEG
CONTROL DEADBAND	XX.X	XX.X	DEG
NORMAL STAGEDELAY	XX.X	XX.X	SEC
FAST STAGE DELAY	XX.X	XX.X	SEC
SETPOINT	S1	X.X PSIG	PT XX.X DEGF
MODE	AUTO		CP XX.X PCT
STATE	FAILED		

### Process Temperature Setpoints Screen

The following table lists the data entry and information fields on the screen and a description of their purposes.

TERM	DEFINITION	RANGE
<b>NORMAL BANDWIDTH</b>	Adjusts the sensitivity of the time proportional control routine.	0-20 DEG
<b>CONTROL DEADBAND</b>	The capacity will not be adjusted if the Process Temperature is within the control deadband.	0-20 DEG
<b>NORMAL STAGEDELAY</b>	The Normal Stage Delay Timer starts when the Suction Pressure exceeds the Control Deadband. When it expires, a stage will be added or removed as appropriate	1-999 SEC
<b>FAST STAGE DELAY</b>	The Fast Stage Delay Timer starts when the Suction Pressure exceeds the Normal Bandwidth.	1-999 SEC
<b>SETPOINT</b>	The current control setpoint group and value (reference).	N/A
<b>PROCESS TEMP</b>	The current Process Temperature value (reference)	N/A
<b>CAPACITY</b>	The current Capacity (reference)	N/A
<b>RECIPMODE</b>	The current compressor mode (reference).	N/A
<b>RECIPSTATE</b>	The current compressor state (reference).	N/A

### Process Temp Control Setpoints Definitions

#### MISC Control

The MISCELLANEOUS CONTROL screen provides setpoints and controls for various system parameters.

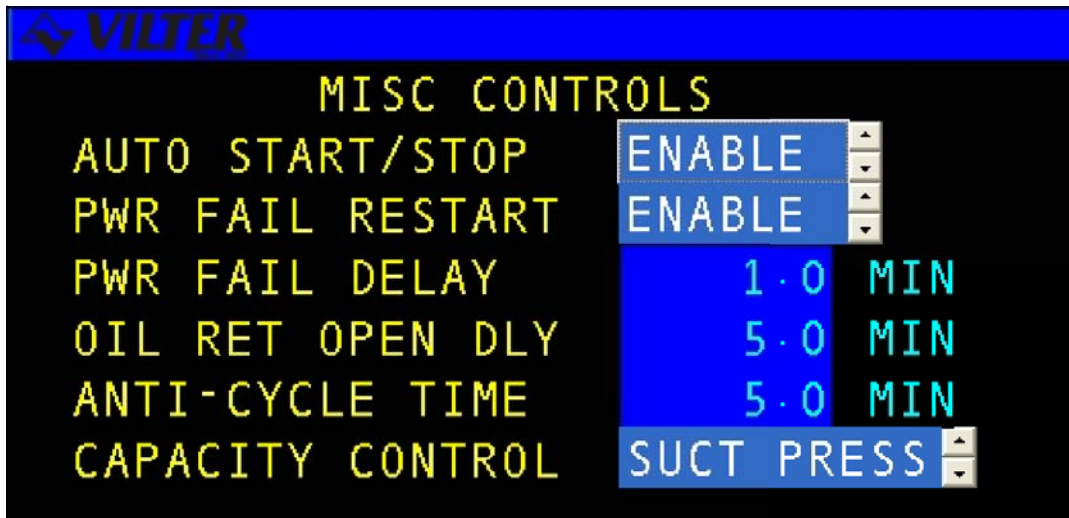

Miscellaneous Control Screen

The following table lists the data entry fields and a description of their purposes.

<b>TERM</b>	<b>DEFINITION</b>	<b>RANGE</b>
<b>AUTO START/STOP</b>	When Auto Start/Stop is Enabled, the compressor will start and stop automatically in the Automatic and Auto-Remote modes.	ENABLE/ DISABLE
<b>POWERFAIL RESART</b>	When Power Fail Restart is Disabled, the compressor will be forced off-line after a power failure occurs. When Enabled, the compressor will be available to auto-restart as long as the power has not been off for longer than the Power Fail Restart Delay.	ENABLE/ DISABLE
<b>POWERFAIL RESTART DELAY</b>	This is the maximum amount of time a compressor is allowed to be without power before being allowed to auto-restart when the power returns.	0 - 999 MIN
<b>ANTI-CYCLE TIME</b>	This is the amount of time that the compressor will be able to restart after the STOP hot key is pushed.	1-30 MIN

### Miscellaneous Control Definitions

#### LOGS Hot Key

The **LOGS** hot key is fully described in Chapter 3, Logging Functions.

#### MENUS Hot Key

The **MENUS** hot key is fully described in Chapter 4, Menu Functions.



## Chapter 3

# *Logging Functions*

The Viltech records the systems parameters and conditions for later use in a set of logs. Each log has a limit on the number of entries that it can store, so as the log fills-up the oldest entries are replaced by the most recent ones. The system maintains the following standard logs.

- Operations Log
- Trend Log
- Alarm Log
- Failure Log
- User Log

Log screens usually contain more data than the LCD display area can show at one time. In order to view the entire set of information the operator uses the function keys. For the specific working procedure of log screens please refer to the log screen section in Chapter 1.

## **Logging Functions Technical overview**

The following sections will discuss the overall function of each of the five standard logs.

### **Operations Log**

The **OPERATIONS LOG** displays a list of the system operating conditions for the last hour at 30-second intervals and has a limit of 255 recorded data entries. An extra entry is made to the Operations Log when special events occur, such as alarms, failures or system reset. When an alarm, failure, or OEM failure occurs a special indicator is also placed next to the logged parameter causing the problem. Typically the data recorded in this log will be the analog inputs, system state variables and alarm information.

**Trend Log**

The format of the TREND LOG is identical to the operations log. The Trend Log allows the user to define the recording interval (Default 15 minutes) and has a limit of 255 recorded data entries. A special entry is made to the Trend Log when certain events occur similar to the Operations Log. Indicators and highlighting are used to identify parameters causing alarms or failures as in the Operations Log.

**Alarm Log**

The ALARM LOG is a record of the last 100 system alarms. When an alarm first occurs an alarm entry is made in the log. The process is repeated until the maximum of 100 entries is reached. Alarms previously logged are then replaced by more recent alarms detected.

**Failure Log**

The FAILURE LOG is a record of the last 100 failures. When a failure first occurs a failure entry is made in the log. The process is repeated until the maximum of 100 entries is reached. Failures previously logged are then replaced by more recent failures detected.

**User Log**

The USER LOG is a record of the last 50 users who logged on to the system. An entry is made into this log when a user logs on to the system. The process is repeated until the maximum of 50 entries is reached. Users previously logged on are then replaced by users who have more recently logged on

## Logging Functions Operating Procedures

The LOG FUNCTION is accessed by the operator through the LOGS hot key. This hot key allows the user to view or erase any of the systems available logs. A diagram of the available menu options under the LOGS hot key is shown below. The operator simply selects the menu item of the log they wish to access using standard menu screen operating procedures.

### LOGS

#### 1. VIEW LOGS

1. OPERATIONS LOG
2. TREND LOG
3. ALARM LOG
4. FAILURE LOG
5. USER LOG

#### 2. CLEAR LOGS

1. OPERATIONS LOG
2. TREND LOG
3. ALARM LOG
4. FAILURE LOG
5. USER LOG

#### 3. CLEAR ALL LOG

1. NO
2. YES

The following sections will provide an operating overview of the system logs.

## Operations and Trend Logs

The **OPERATIONS AND TREND LOGS** typically store the same parameters. The only difference is the time interval at which entries are made. The logs will also indicate which parameters have caused an alarm or failure by placing an indicator next to the responsible parameter. The following table shows the indicators used for each of the system alarm or failure states.

INDICATOR	STATE
A	Alarm State
F	Failure State
O	OEM Failure State

*NOTE: The Operations and Trend Logs on compressors only accumulate data when the compressor is running. However, alarm and failures will still be logged when the compressor is stopped.*

The following is an example of the first page of the Operations Log. This particular log has 7 different pages to display all the data.

PG 1/7 OPERATIONS LOG			hh:mm:ss
TIME	DATE	TYPE	
HH:MM:SS AM	MM:DD:YY	MODES	
HH:MM:SS AM	MM:DD:YY	MODES	
HH:MM:SS AM	MM:DD:YY	MODES	
HH:MM:SS AM	MM:DD:YY	MODES	
HH:MM:SS AM	MM:DD:YY	MODES	
HH:MM:SS AM	MM:DD:YY	MODES	
HH:MM:SS AM	MM:DD:YY	MODES	

**Operations Log Page**

The following data descriptions apply to the Operations and Trend Logs.

PARAMETER	DEFINITION
<b>TIME</b>	The time the problem occurred.
<b>DATE</b>	The date the problem occurred.
<b>TYPE</b>	The type of log entry.
<b>ENTRY DESCRIPTION</b>	Description of the log entry if applicable.
<b>ALARM LEVEL</b>	The status level of the alarm/failure if one occurred.
<b>DATA</b>	The analogs and other data recorded for the system.

**Operations Log Definitions**

## Alarm and Failure Logs

The **ALARM AND FAILURE LOGS** are records of the system alarm and failure conditions. The screen format is the same for both logs, except for the TYPE column. The following is an example of the first page of the Alarm log.

PG 1/2	ALARMLOG	hh:mm:ss
TIME	DATE	TYPE
HH:MM:SS AM	MM:DD:YY	ALARMS
HH:MM:SS AM	MM:DD:YY	ALARMS
HH:MM:SS AM	MM:DD:YY	ALARMS

**Alarm Log Page**

The Alarm and Failure logs will contain the data described in the following table for each entry.

PARAMETER	DEFINITION
TIME	The time the problem occurred.
DATE	The date the problem occurred.
TYPE	The type of problem that occurred.

**Alarm Log Definitions**

## User Log

The **USER LOG** is a record of the last 50 user logon's for the system. The following is an example of the first page of a typical User Log screen.

PG 1/2	USERLOG	hh:mm:ss
TIME	DATE	USER
hh:mm:ss AM	mm/dd/yy	01
hh:mm:ss AM	mm/dd/yy	01
hh:mm:ss AM	mm/dd/yy	01
hh:mm:ss AM	mm/dd/yy	01
hh:mm:ss AM	mm/dd/yy	01
hh:mm:ss AM	mm/dd/yy	01
hh:mm:ss AM	mm/dd/yy	01

**User Log Page**

The User log will contain the data described in the following table for each entry.

PARAMETER	DEFINITION
<b>TIME</b>	The time the user logged onto the system.
<b>DATE</b>	The date the user logged onto of the system.
<b>USER</b>	User identification number.

**User Log Definitions**

## Clear Logs

The **CLEAR LOGS** function is typically not available to the user. A special one-time password is required from Vilter Manufacturing to access this function. Please contact the Vilter Manufacturing service department if you desire to clear the logs.

## **Clear All Logs**

The **CLEAR ALL LOGS** menu entry provides a method of erasing all the data currently contained in all the logs available on your system. After choosing to clear all logs the user will be prompted by a confirmation screen to verify the selection. If the user decides to continue with the clearing of the logs, a momentary screen will appear with a message stating that the logs have been erased. The action of clearing the logs requires a special password. The message "ACCESS DENIED" indicates that the user does not have privilege to perform this function. If a standard user password will not allow access to clear the logs, contact your control system provider for assistance.

## **Set Log Rate**

The **SET LOG RATES** menu entry allows the user to set the rate in minutes for collection of the logging data. The Trend Log Rate (standard) can be set to the rate in minutes which is most desirable for your system and operational needs.





## Chapter 4

# *Menu Functions*

The **MENUS** hot key allows the user to access miscellaneous screens that do not fall under one of the other hot key categories. The system supports the following four additional menus:

- Logon User
- Logoff User
- Diagnostics
- System Set-up

## Technical Overview

Additional menus are available for system logon and logoff, basic system information for diagnostic purposes and set-up of various system parameters, passwords, access levels and initialization sequences.

### Logon User

To log onto the system the user selects the **LOGON USER** option and enters a numeric user password assigned by the Viltech system manager. Once a password is accepted the system allows access according to the preset restrictions set by the Viltech according to the access level. Please review the Screen Access Levels section for an explanation of access levels.

### Logoff User

To logoff of the system the user selects the **LOGOFF USER** menu option. The system then logs the user off and changes the access levels to the default values. Please review the Screen Access Levels section for an explanation of access levels.

### Automatic Log Off

A user will be automatically logged off after a 10-minute period of no keyboard activity. The system automatically returns to the main status screen.

## **Diagnostics Menu**

The **DIAGNOSTICS** menu option permits the user to view basic information about the system. The information can then be used to readily troubleshoot problems when they occur. Most of the screens available under this menu option are view-only screens and information displayed cannot be changed by the user. There are a few screens available which have selected parameters for which data entry is possible. The menu selections include System Info, View Discrete I/O, View Analogs, View Network Communications and Override Discrete I/O.

### **System Information**

Selecting **SYSTEM INFO** will display the System Information screen. Information displayed includes the dates for last memory initialization and system reset, status on system options such as modem communications and frame statistics.

### **View Discrete I/O**

The **VIEW DISCRETE I/O** screens display discrete Input and Output information from the unit. Channel assignment, signal name, input/output designation and current state of the signal are displayed for discrete I/O racks.

### **View Analogs**

The **VIEW ANALOGS** screens display analog signal information from the unit. Channel assignment, signal name, current value, units of measurement and hexadecimal equivalent values are displayed.

### **View Network Comm**

The **VIEW NETWORK COMM** selection displays the current communication status for various units involved in system communication such as the modem, PC or other network connections. Current status, last error, total error count and message count are examples of the parameters which may be displayed here.

### **Override Discrete I/O**

The **OVERRIDE DISCRETE I/O** screen allows the user to set the state of certain discrete outputs. It also allows the user to simulate certain discrete inputs to an active or inactive state. This feature is for diagnostics purposes only and will only function if the system is off-line.

*NOTE: The user is responsible for knowing the consequences of manual control actions. Please use with caution.*

## Set-up Menu

The **SET-UP** menu allows the user to perform miscellaneous set-up changes, which are used to configure the system.

## Set Clock

The **SET CLOCK** screen allows the user to enter the current day and date. The system clock may be set to a 12 or 24 hour mode.

*The correct hour, minute and second for the current time must be entered as 24 hour time.*

## Calibrate Sensors

Two types of calibration can be accomplished using the Dynamic or Static Sensor Calibration options. Dynamic Sensor Calibration is selected when the user wishes to change current sensor range values. Static Sensor Calibration is selected to recall sensor calibration values after a return to factory configuration or after a system software or hardware change, which would effect sensor calibration.

## Dynamic Sensor Calibration

**DYNAMIC SENSOR CALIBRATION** is the process of adjusting the readings of the Viltech analog sensors to remove small inaccuracies. The calibration process is performed from the Dynamic Sensor Calibration screen. The approach used for dynamic calibration divides the sensor range into three zones. When the value being calibrated is in the upper zone (above 66%) the upper range limit is allowed to change by a maximum of 5% and the lower range limit remains constant. This is referred to as a span change. When the value being calibrated is in the lower zone (below 33%) the lower range is allowed to change by a maximum of 5% and the upper range remains constant. This is referred to as an offset change. When the value being calibrated is in the middle zone (33% to 66%) both end points are allowed to move a maximum of 5% (typical) resulting in both a span and offset change. For best results calibration should be performed both at the operating value and at or near the lower limit. Several calibration attempts may be required to zero-in on the correct values over the full operating range.

## Static Sensor Calibration

**STATIC CALIBRATION** is performed to reset or restore sensor calibration values after a hardware, software or factory configuration change. The previous dynamic calibration results are shown on the Static Sensor Calibration screen to allow the user to re-enter the values manually or perform a Restore operation to reset the minimum and maximum range values for the previous calibration results.

Sensors should only be calibrated by qualified personnel and always against devices known to be accurate. Refer to the information for the Calibrate Sensors screen in the Additional Menus Operating Procedures section of this manual.

## Passwords

The Viltech system manager will assign user numbers, passwords, screen read and write access levels and screen access requirements for all users. A user is defined as an individual or group of individuals who will be using the system. Each user of the Viltech can be assigned a numeric password to define their operating privileges. The system manager's password will initially be assigned by Vilter Manufacturing upon system configuration and may be changed by the system manager if desired. All other users will be assigned a six digit password, which has an associated read and write access level. A user must enter the numeric password to log onto the system to obtain access beyond the basic system default access levels. Once a user is finished performing the task required, he may then logoff manually. If the logoff option is not selected, logoff will occur automatically after a 10 minute period of no keypad activity.

## Adding/Deleting Users

The system manager is able to add or delete users from the Viltech by accessing the **ADD/DELETE USER** screen. A user is added by defining a password, read access level and write access level. The higher the access level the more privileges the individual will have on the system. Access levels will range from 0 to 9, with the system manager being assigned 9 for full access. The read and write features will each have their own access level with the left number being the read access level and the right number being the write access level. The read access level defines the access level at which a user may view a screen. The write access level defines the access level at which a user may change data on a screen. When a user is deleted this information is removed from the list. The maximum number of users is 10. When the system is set to Factory Configuration, User 01 is given a password of 999999 with full access. This should be changed after the password system is set-up.

## Screen Access Levels

The system manager can assign read and write access levels to groups of screens on the Viltech by choosing the **SCREEN ACCESS LEVEL** menu selection. The specific screens available for protection will vary depending on the system configuration. Some examples of screens which might be considered for limited access are control, setpoint, calibration and initialization screens. Access for screens such as set date and time and set log rate may be less restricted.

## Initialization

The **INITIALIZATION** menu selection under the Set-up group allows the user to reset the system or restore factory setpoints.

## Power Fail Reset

Choosing Power Fail Reset causes the software to restart using current setpoints as if a power failure occurred.

## Set Factory Configuration

**SET FACTORY CONFIG** will initialize the system using the preset default factory configuration values. All the system setpoints and calibration data should be recorded either manually or electronically prior to performing a Factory Configuration.

## Configuration

The **CONFIGURATION** menu contains menu items which need to be configured once at system startup or which do not typically require modification.

## Display

The **DISPLAY** set-up screen allows the user to set the units of measure and the default display configuration.

## Communication

The **COMMUNICATIONS CONFIGURATION** screen (optional) allows the user to set the hardware communications parameters for the Modbus communications protocol.

## Set Operating Status

The **SET OPERATING STATUS** screen allows the user to reset the runtime and startup information of the compressor in the event that the data is lost due to a board change or factory configuration operation.

## Staging Configuration

The **SETUP STAGES** screen allows the user to configure the capacity stages for the compressor. The operator can assign the type of Stage and assign a capacity value for each stage. The type of stages that can be selected are: None (not used), Loader (energize to load), or Unloader (energize to unload). A capacity value is also assigned to the fully unloaded condition.

## Control Configuration

The Control Configuration screen allows the operator to select refrigerants and enable Viltech options.

## Adjust Contrast

The Adjust Contrast screen allows the user to adjust contrast to the display.

## Operational Procedures

A diagram of the screens available under the **MENUS** hot key is shown below. Note that some screens are optional and may not be accessible on all compressors.

### MENUS

1. LOGON USER
2. LOGOFF USER
3. DIAGNOSTICS

1. SYSTEM INFO
2. VIEW DISC I/O

1. CHANNEL 1-8
2. CHANNEL 9-16

3. VIEW ANALOGS CHANNEL 1-8 CHANNEL 9-16 (Two stage only)

1. CHANNEL 1-8
2. CHANNEL 9-16

4. COMMUNICATIONS STATUS
5. OVERRIDE I/O

1. CHANNEL 1-8
2. CHANNEL 9-16

### 4. SET-UP

1. SET CLOCK
2. CALIBRATE

1. DYNAMIC SENSOR CALIB.
2. STATIC SENSOR CALIB.

### 3. PASSWORDS

1. ADD/DELETE USERS
2. SCREEN ACCESS LEVELS

### 4. INITIALIZATION

1. POWER FAIL RESET
2. SET FACTORY CONFIG
3. SETPOINT SAVE/RESTORE
4. SAVE/RESTORE STATUS

### 5. CONFIGURE HARDWARE

1. DISPLAY
2. COMMUNICATION
3. SET OPERATING STATUS
4. STAGING CONFIGURATION
5. CONTROL CONFIGURATION
6. ADJUST CONTRAST

### Additional Menus Diagram

## Logon User

To log onto the system the user selects the **LOGON USER** option and enters the appropriate user password. Once a password is accepted the system allows access according to the restrictions preset by the Viltech system manager. Below is an example of a logon.

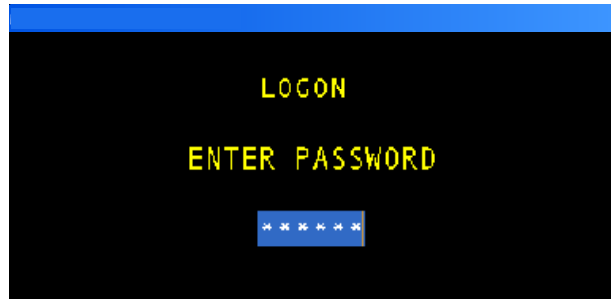

### Logon User Screen

The following table lists the data entry fields and a description of their purpose.

TERM	DEFINITION	RANGE
PASSWORD	The designated password for a particular user.	0-999999

### Logon User Definitions

*NOTE: The password is not displayed when typed. Instead, "\*" characters are displayed to avoid anyone overseeing the typed password.*

## Logoff User

To logoff of the system the user selects the **LOGOFF USER** menu option. A temporary screen will then appear to signal the initiation of the logoff. The system then logs the user off and changes the access levels to the default values. The system automatically returns to the main status screen. A user will be automatically logged off after a 10 minute period of no keyboard activity.

## Diagnostics

The **DIAGNOSTICS** menu option permits the user to view and in some cases alter basic information about the system. The menu selections include viewing System Information, Viewing IO, Analogs; and viewing Network Communications.

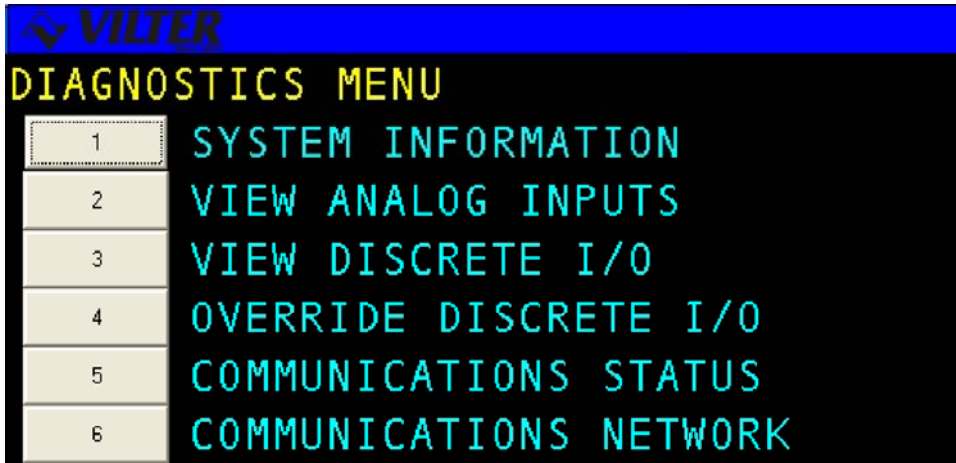

**Diagnostics Screen**

## System Information

The **SYSTEM INFORMATION** screen is used to provide the user with the system options and software configuration status. An example of a System Information screen is shown below.

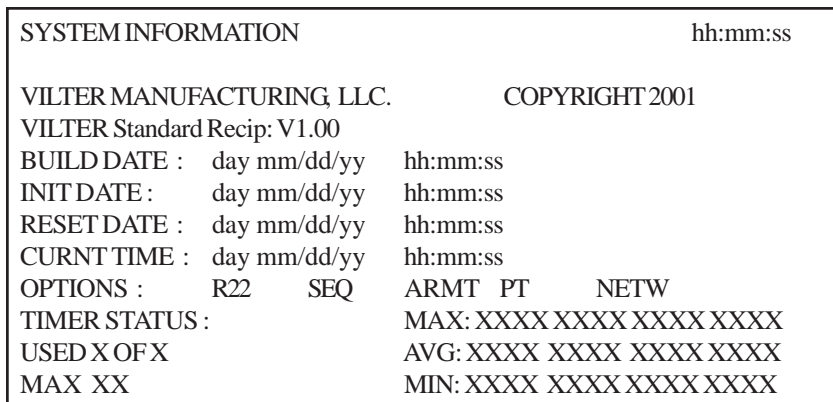

**System Information Screen**



The following table lists the various parameters displayed on the screen.

PARAMETER	DEFINITION
VILTER, INC. RECIP COMP. VO.XX	The name and version number of the installed software.
BUILDDATE	The date the system was last built.
INTDATE	The date the system was initiated.
RESETDATE	The date and time the system was last reset.
CURNTIME	The current date and time for this panel.
OPTIONS	The status of various options are shown on the lower section of the screen.
TIMERSTATUS	The number of timers currently being used, the total number of available timers, and the maximum number of timers used since the last reset.

### System Information Definitions

#### View Discrete I/O

The View Discrete I/O screens are information screens used for viewing purposes only as shown in the following example.

*NOTE: The I/O channels are used for optional equipment.*

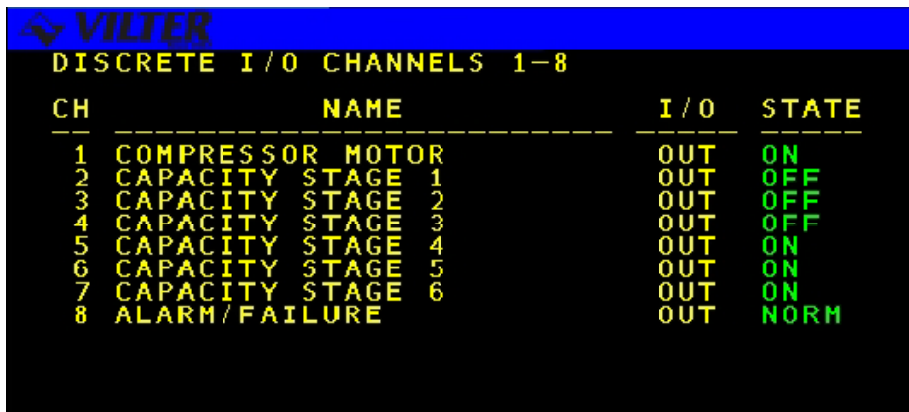

CH	NAME	I/O	STATE
1	COMPRESSOR MOTOR	OUT	ON
2	CAPACITY STAGE 1	OUT	OFF
3	CAPACITY STAGE 2	OUT	OFF
4	CAPACITY STAGE 3	OUT	OFF
5	CAPACITY STAGE 4	OUT	ON
6	CAPACITY STAGE 5	OUT	ON
7	CAPACITY STAGE 6	OUT	ON
8	ALARM/FAILURE	OUT	NORM

Discrete I/O Rack 1A Screen

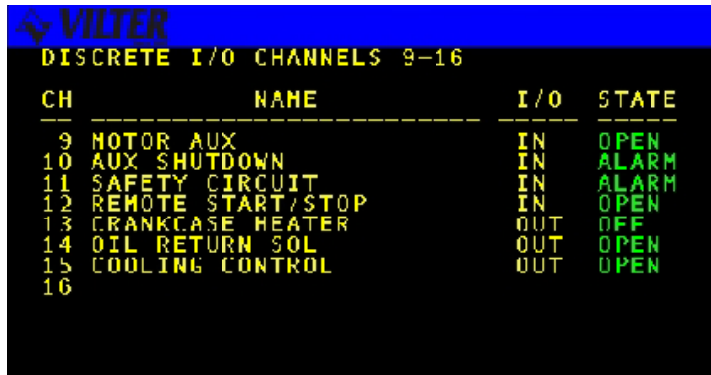

CH	NAME	I/O	STATE
9	MOTOR AUX	IN	OPEN
10	AUX SHUTDOWN	IN	ALARM
11	SAFETY CIRCUIT	IN	ALARM
12	REMOTE START/STOP	IN	OPEN
13	CRANKCASE HEATER	OUT	OFF
14	OIL RETURN SOL	OUT	OPEN
15	COOLING CONTROL	OUT	OPEN
16			

**Discrete I/O Rack 1B Screen**

The following table lists the various parameters displayed on the screen.

PARAMETER	DEFINITION
CH	The discrete channel number
NAME	The name of the discrete signal.
I/O	Shows whether the discrete is an input or an output.
STATE	The current state of the discrete signal.

**Discrete I/O Rack Definitions**

### View Analogs

The VIEW ANALOG Inputs screen can be viewed by the operator and will be displayed on a screen similar to the following example.

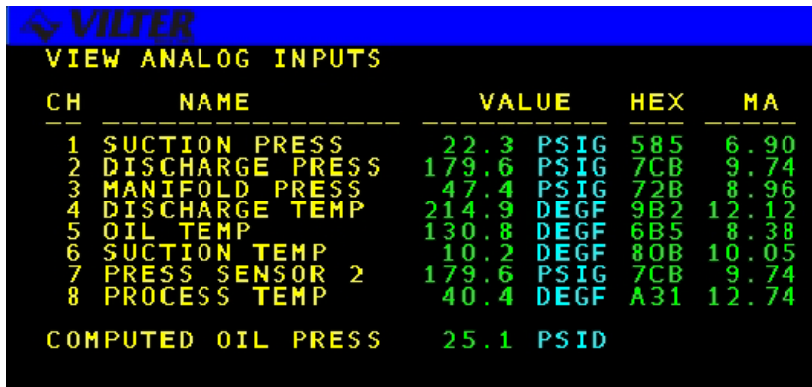

CH	NAME	VALUE	HEX	MA
1	SUCTION PRESS	22.3 PSIG	585	6.90
2	DISCHARGE PRESS	179.6 PSIG	7CB	9.74
3	MANIFOLD PRESS	47.4 PSIG	72B	8.96
4	DISCHARGE TEMP	214.9 DEGF	9B2	12.12
5	OIL TEMP	130.8 DEGF	6B5	8.38
6	SUCTION TEMP	10.2 DEGF	80B	10.05
7	PRESS SENSOR 2	179.6 PSIG	7CB	9.74
8	PROCESS TEMP	40.4 DEGF	A31	12.74
	COMPUTED OIL PRESS	25.1 PSID		

**Analog Inputs Screen (Channels 1-8)**

The following table lists the various parameters displayed on the screen.

<b>PARAMETER</b>	<b>DEFINITION</b>
<b>CH</b>	The analog channel number.
<b>NAME</b>	The name of the analog signal.
<b>VALUE</b>	The decimal value of the analog input.
<b>HEX</b>	The hexadecimal value of the analog input.

### **Analog Input Definitions**

## Communication Status

The **Communication Status** screen allows the user to monitor the status of the system's communication links. The screen shown below is an example of a Communication Status screen.

COMMUNICATION STATUS				hh:mm:ss
STATUS	MODEM	PC	MASTR	DF1
LASTERR	FAIL	FAIL	FAIL	FAIL
TOTALERR	XXXX	XXXX	XXXX	XXXX
MSG COUNT	XXXX	XXXX	XXXX	XXXX
VILTER	DF1	MODBUS	NETWORK	
UNIT: X	UNIT: X	UNIT X	IN CTRL: NO	

**Communication Status Screen**

The following table lists the various parameters displayed on the screen.

PARAMETER	DEFINITION
<b>STATUS</b>	The status of the link to a specific unit, either pass or fail. MODEM indicates the status for the optional modem link, PC indicates the status for the optional PC or Modbus connection, Master indicates the status for an optional.
<b>LASTERR</b>	The last error message received from each unit. The field is blank if no errors have been received.
<b>TOTALERR</b>	A hexadecimal counter of the total number of errors received by each unit. Time-out errors do not increase the total. The counter rolls over at FFFF.
<b>MSG COUNT</b>	A hexadecimal counter of the number of messages received by each unit. The counter rolls over at FFFF.
<b>VILTER UNIT NUMBER</b>	The unit number for use when the compressor is communicating with a Vilter master panel.
<b>MODBUS UNIT NUMBER</b>	The Unit Number used when the compressor is communicating using the Modbus communication protocol.
<b>NETWORK IN CONTROL</b>	Indicates that the Network master is in control of the compressor.

**Communication Status Definitions**

## Override Discrete I/O

The **VERRIDE DISCRETE I/O** screens allow discrete Inputs and Outputs to be simulated whenever the compressor is stopped (some channels are not assigned). Any overridden channels will be restored to normal when the compressor is started.

CH	NAME	I/O	STATE
1	COMPRESSOR MOTOR	OUT	AUTO
2	CAPACITY STAGE 1	OUT	AUTO
3	CAPACITY STAGE 2	OUT	AUTO
4	CAPACITY STAGE 3	OUT	AUTO
5	CAPACITY STAGE 4	OUT	AUTO
6	CAPACITY STAGE 5	OUT	AUTO
7	CAPACITY STAGE 6	OUT	AUTO
8	ALARM/FAILURE	OUT	AUTO

Override Discrete I/O Rack 1A Screen

CH	NAME	I/O	STATE
9	MOTOR AUX	IN	AUTO
10	AUX SHUTDOWN	IN	AUTO
11	SAFETY CIRCUIT	IN	AUTO
12	REMOTE START/STOP	IN	AUTO
13	CRANKCASE HEATER	OUT	AUTO
14	OIL RETURN SOL	OUT	AUTO
15	COOLING CONTROL	OUT	AUTO
16			

Override Discrete I/O Rack 1B Screen

The following table lists the various parameters displayed on the screen.

PARAMETER	DEFINITION
CH	The discrete channel number.
NAME	The name of the discrete signal.
I/O	Shows whether the discrete is an input or an output.
STATE	The current state of the discrete override. AUTO indicates the output is in automatic control, OFF indicates that the output is de-energized, and ON indicates that the output is energized.

### Override Discrete I/O Rack Definitions

## Set-up

The **SET-UP** menu allows the user to perform miscellaneous set-up changes, which are used to configure the system. The menu selections include Set Time and Date, Calibrate Sensors, Password Control, Initialization, and Configuration.

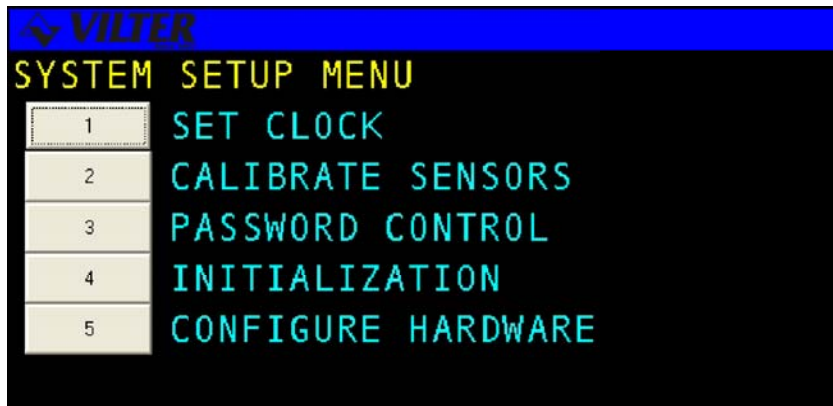

Set-up Menu Screen

## Set Clock

The **SET CLOCK** screen allows the user to change the date, clock mode or time of day for the system. The clock mode gives the user the ability to display time in 24 hour or 12 hour modes. An example of the screen is shown below.



Set Time & Date Screen

The following table lists the data entry fields and a description of their purpose.

TERM	DEFINITION	RANGE
DAY	The current day of the week.	SUN - SAT
DATE	The current date entered as month, day, and year. All six digits must be entered. For example, to set the date to March 2nd, 2001, enter 03 02 01. The slash delimiter does not need to be entered.	MM/DD/YY
24 HOUR TIME	The current time of day which must be entered in military 24 hour format. This field is initially blank. The user only needs to enter enough digits to specify the required time. All unused digits will be set to zero. The colon delimiter does not need to be entered.	00:00:00 23:59:59
CLOCKMODE	The time display mode for the system, either 12 or 24 hour format.	12 HOUR 24 HOUR

### Set Time & Date Definitions

### Calibrate Sensors

The **CALIBRATE SENSORS** menu allows the user to adjust the range of sensor inputs. There are two types of calibration, Dynamic and Static. Dynamic calibration is used primarily for accurate calibration of sensor inputs where the sensor is being compared to known system conditions. Static calibration is performed to reset or restore sensor calibration values after a hardware, software or factory configuration change.

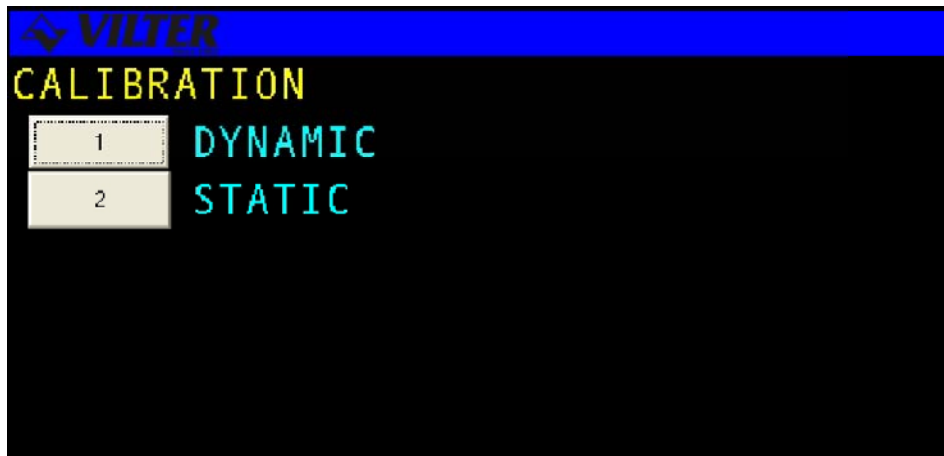

Calibrate Sensors Screen

## Dynamic Sensor Calibration

**DYNAMIC SENSOR CALIBRATION** is described more fully on page 87 of this chapter.

DYNAMIC CALIBRATION		hh:mm:ss
CH	NAME	VALUE
1	SUCTION PRESS	XXX.X PSIG
2	DISCHARGE PRESS	XXX.X PSIG
3	OIL PRESS	XXX.X PSIG
4	DISCHARGE TEMP	XXX.X DEGF
5	OIL TEMP	XXX.X DEGF
6	SUCTION TEMP	XXX.X DEGF
7	PRESS.2 OPTIONAL	XXX.X PSIG
8	PROCESS TEMP	XXX.X DEGF
SPAN CORRECTION 0.0		
OFFSET CORRECTION 0.0		

### Dynamic Sensor Calibration Screen

The following table lists the data entry fields and a description of their purpose.

TERM	DEFINITION
<b>CH</b>	The discrete channel number
<b>NAME</b>	The name of the discrete signal.
<b>VALUE</b>	Current dynamic value of the discrete signal.
<b>UNIT</b>	The unit of measurement for the discrete signal value.

### Dynamic Sensor Calibration Definitions



## Static Sensor Calibration

**STATIC SENSOR CALIBRATION** is described more fully on page 87 of this chapter.

STATIC CALIBRATION		hh:mm:ss	
CH	NAME	MIN	MAX
1	SUCTION PRESS	XXX.X	XXX.X PSIA
2	DISCHARGE PRESS	XXX.X	XXX.X PSIG
3	OIL PRESS	XXX.X	XXX.X PSIA
4	DISCHARGE TEMP	XXX.X	XXX.X DEGF
5	OIL TEMP	XXX.X	XXX.X DEGF
6	SUCTION TEMP	XXX.X	XXX.X DEGF
7	PRESS2 OPTIONAL	XXX.X	XXX.X PSIG
8	PROCESS TEMP	XXX.X	XXX.X DEGF
SPAN CORRECTION		0.0	
OFFSET CORRECTION		0.0	

**Static Calibration Sensors Screen**

The following table lists the data entry fields and a description of their purpose.

<b>TERM</b>	<b>DEFINITION</b>
<b>CH</b>	The discrete channel number
<b>NAME</b>	The name of the discrete signal.
<b>VALUE</b>	Current dynamic value of the discrete signal.
<b>UNIT</b>	The unit of measurement for the discrete signal value.

**Static Calibration Definitions**

## Password Control

The Viltech system manager will assign each user a password to define their operating privileges. The password sets privileges for screen read and write access. The read access level defines the access level required to view a screen, while the write access level defines the access level required to change data on a screen.

Each user can be assigned a six digit password, which has associated read and write access levels. The higher the access level the more privileges the individual will have on the system. Read and write privileges will each have their own access level. The system manager can assign read and write access levels to numerous screens on the Viltech. The Viltech password protection is controlled through two system screens, the Add Delete User screen and the Screen Access Level screen which are discussed in the following sections.

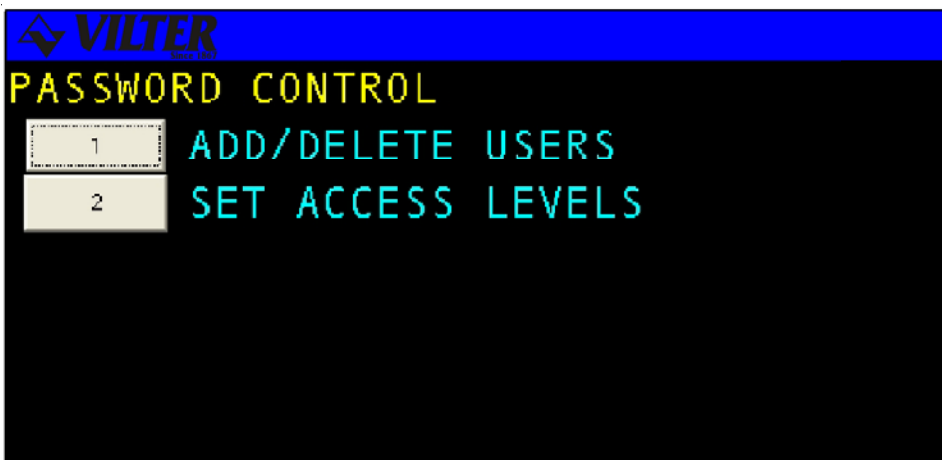

**Password Control Screen**

## Add/Delete User

The **ADD/DELETE USER** screen will allow for the addition or deletion of a user. This function is performed by creating or deleting a password and corresponding access levels for a particular user. An example of the screen is shown below.

ADD DELETE USERS					hh:mm:ss	
USER	PASSWORD	LEVEL	USER	PASSWORD	LEVEL	
		R / W			R / W	
1	XXXXXX	XX	6	XXXXXX	XX	
2	XXXXXX	XX	7	XXXXXX	XX	
3	XXXXXX	XX	8	XXXXXX	XX	
4	XXXXXX	XX	9	XXXXXX	XX	
5	XXXXXX	XX	10	XXXXXX	XX	

**Add/Delete Screen**

The following table lists the data entry fields and a description of their purpose.

TERM	DEFINITION	RANGE
<b>PASSWORD</b>	The desired password for each user.	0 - 999999
<b>LEVEL</b>	The desired read and write levels for each user. The first digit is the read level and the second is the write level. The lowest level of access is 0 and 9 is the highest level.	0 - 9 (per digit)

**Add/Delete User Definitions**

## Access Levels

Screen Access authorization levels are selected for various screen sections using the **SCREEN ACCESS LEVELS** screen. This allows the system manager to restrict user access to certain areas of the system. An example of a Screen Access Level screen is shown below.

SCREENACCESSLEVELS		hh:mm:ss	
FUNCTION	LEVEL	FUNCTION	LEVEL
START	XX	MISC CONTROL	XX
STOP / PC	XX	SET DATE/TIME	XX
STOP / MODEM	XX	CALIBRATION	XX
CHANGE MODES	XX	CHNG PASSWORDS	XX
SETPOINTS	XX	INITIALIZATION	XX
CAPACITY CNTRL	XX	CONFIGURATION	XX
SCHEDULING	XX	SET LOG RATES	XX

### Screen Access Level

TERM	DEFINITION	RANGE
<b>ACCESSLEVEL READ/WRITE</b>	The desired read and write levels for each user. The first digit is the read level and the second is the write level. The lowest level of access is 0 and 9 is the highest level.	<b>0 - 9 (per digit)</b>

### Screen Access Level Definitions

## Initialization

The **INITIALIZATION** menu selection under the Set-up group includes Power Fail Reset, Setpoint Save/Restore, Save Restore Status, and Set Factory Config. These screens are discussed further in the following sections.

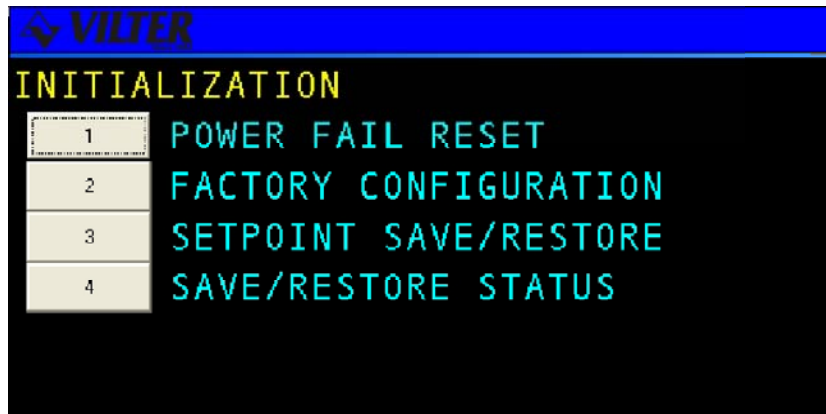

Initialization Screen

## Power Fail Reset

Selection of this initialization option causes the software to restart using the current setpoints as if a power failure occurred. When the user selects **POWER FAIL RESET**, a confirmation screen will be displayed asking the user to verify that he wishes to reset the system. If the user answers yes the system will restart as if a power failure occurred.



Power Fail Reset Screen

## 1. Set Factory Config

This selection allows the user to reset the system to factory default values. When the user selects the **SET FACTORY CONFIG** menu option a confirmation screen will be displayed asking the user to verify that he wishes to reset the system to the original factory configuration. If the user answers yes the system will be reset and all existing configuration changes will be lost. This includes all logs, set-points, controls, modes, etc. Do not use this option without proper consideration of the results.



Set Factory Configuration Screen

## 2. Setpoint Save/Restore

This function is to be used to save a copy of setpoints from the Viltech to the eeprom of the microprocessor board.



Setpoints Save/Restore Screen

## 3. Save/Restore Status

This screen display will display that a save or a restore of a status has been made.

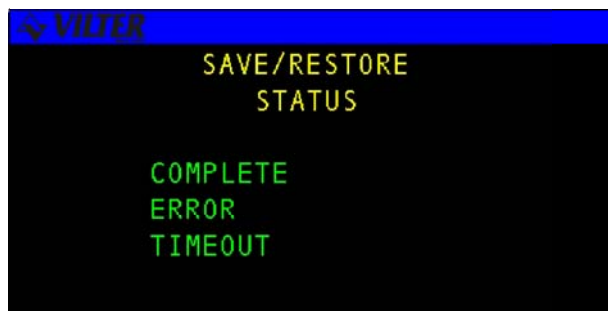

Save/Restore Status Screen

## 4. Configuration

The **CONFIGURATION** menu selection allows the user to set-up various basic system parameters for the display and operation of the compressor. These parameters are usually set-up once and never change.

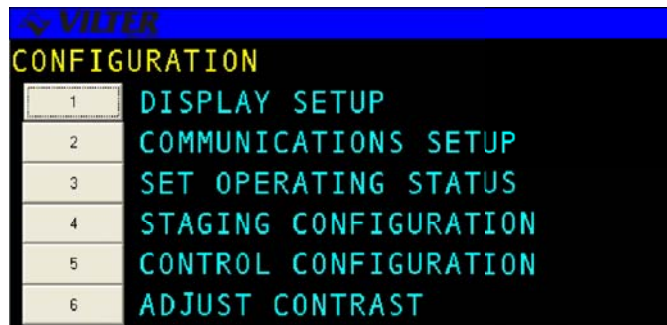

**Configuration Screen**

### Display

The **DISPLAY SET-UP** screen allows the user to configure the display units for all analog parameters and panel name.

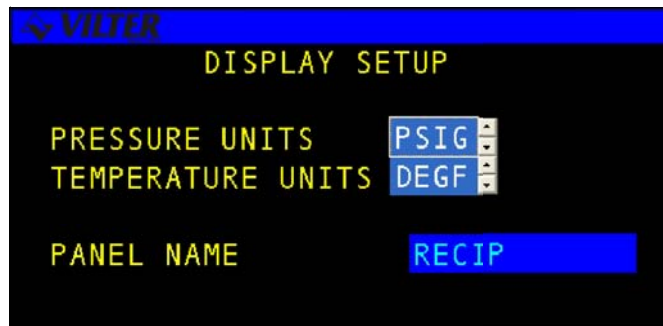

**Display Screen**

The following table list the data entry fields and a description of their purpose.

TERM	DEFINITION	RANGE
PRESSURE UNITS	Selects the units of measure for pressure fields.	PSIG/KPAG/BAR
TEMPERATURE UNITS	Selects the units of measure for temperature fields.	DEGF/DEGC
PANEL NAME	Select panel name to change name of panel by touching clear and using up down arrows to enter letters or characters to name the panel	

**Display Definitions**

## Comm Setup

The following screen is a sample COMMUNICATIONS SET-UP screen for Modbus Communications.

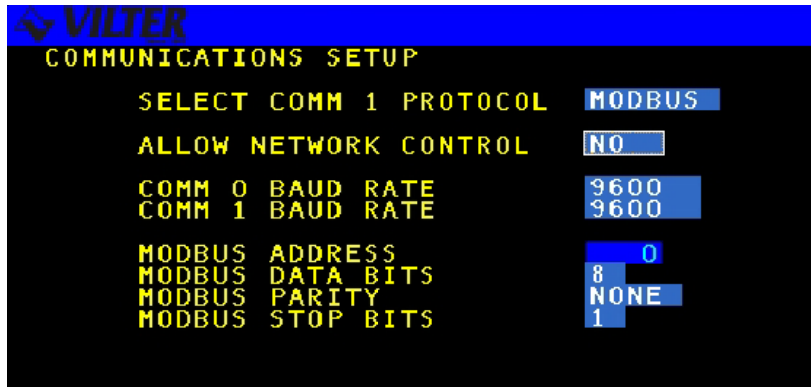

**Communications Screen**

The following table list the data entry fields and a description of their purpose.

TERM	DEFINITION	RANGE
<b>BAUDRATE</b>	Selects the baud rate for Modbus serial communications.	<b>2400/4800/ 9600/ 19200</b>
<b>DATABITS</b>	Selects the number of Databits used for communications.	<b>7/8</b>
<b>PARITY</b>	Sets the Parity used for communications.	<b>None/Odd/ Even</b>
<b>STOPBITS</b>	Sets the number of Stop Bits to be used for communication.	<b>1/2</b>

**Communications Definitions**



## Set Op Stats

The **SET OPERATING STATUS** screen is used to reset the total runtime hours and number of starts following a board change or software update.

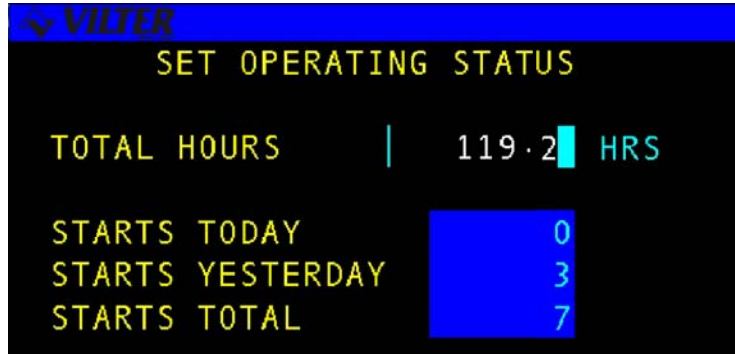

**Set Operating Status Screen**

The following table list the data entry fields and a description of their purpose.

TERM	DEFINITION	RANGE
<b>TOTAL HOURS</b>	Sets the total runtime hours for the compressor.	<b>0-999999.9 HRS</b>
<b>STARTS TODAY</b>	Sets the total number of starts since midnight today.	<b>0-999</b>
<b>STARTS YESTERDAY</b>	Sets the total number of starts for yesterday.	<b>0-999</b>
<b>STARTS TOTAL</b>	Sets to total number of starts for the compressor.	<b>0-999999</b>

**Operating Status Definitions**

## Setup Stages

The following is a sample **STAGING CONFIGURATION STATUS** screen.

The top screenshot shows the following configuration:

STAGE NUM	1	2	3	4	5	6	CAPACITY PCT
0	ON	ON	ON	ON	OFF	OFF	0.0
1	OFF	ON	ON	ON	OFF	OFF	25.0
2	OFF	OFF	ON	ON	OFF	OFF	50.0
3	OFF	OFF	OFF	ON	OFF	OFF	75.0
4	OFF	OFF	OFF	OFF	OFF	OFF	100.0
5	OFF	OFF	OFF	OFF	OFF	OFF	0.0
6	OFF	OFF	OFF	OFF	OFF	OFF	0.0

The bottom screenshot shows the following configuration:

STAGE NUM	1	2	3	4	5	6	CAPACITY PCT
0	ON	ON	ON	OFF	OFF	OFF	0.0
1	OFF	ON	ON	OFF	OFF	OFF	33.0
2	OFF	OFF	ON	OFF	OFF	OFF	66.0
3	OFF	OFF	OFF	OFF	OFF	OFF	100.0
4	OFF	OFF	OFF	OFF	OFF	OFF	0.0
5	OFF	OFF	OFF	OFF	OFF	OFF	0.0
6	OFF	OFF	OFF	OFF	OFF	OFF	0.0

**Staging Configuration Status Screen**

The following table list is the data entry fields and a description of their purpose.

TERM	DEFINITION	RANGE
<b>STAGENUMBER</b>	This field displays the reference number used to identify the state number	
<b>STAGE OUTPUT STATE</b>	Specify if stage is an unloader (open to load). Only list those stages actually used.	ON/OFF
<b>CAPACITYPCT</b>	Selects the capacity for the stage number.	0-100%

**Staging Configuration Status Definitions**

**NOTE:** Stages should be configured starting at Stage 1 and increasing based on the number of Capacity Control Devices available.

## Control Configuration

The following screen enables alarm and fail or fail out and selects the refrigerant.

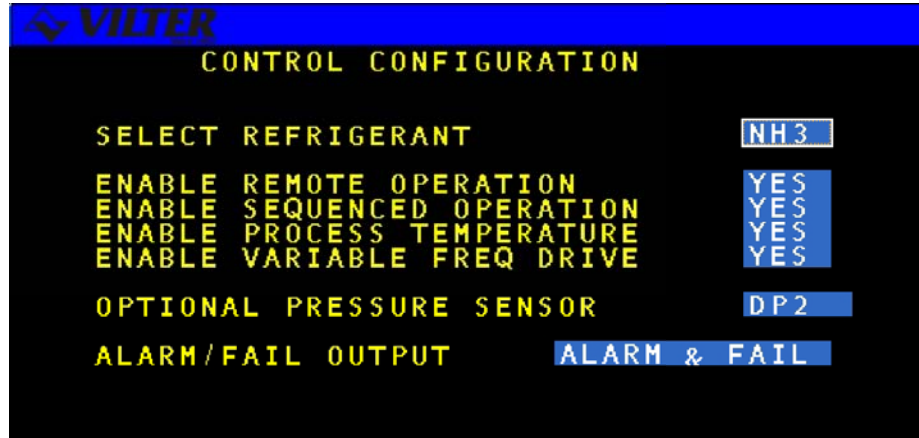

Control Configuration Screen

## Adjust Contrast

This screen allows you to change the contrast of the display.

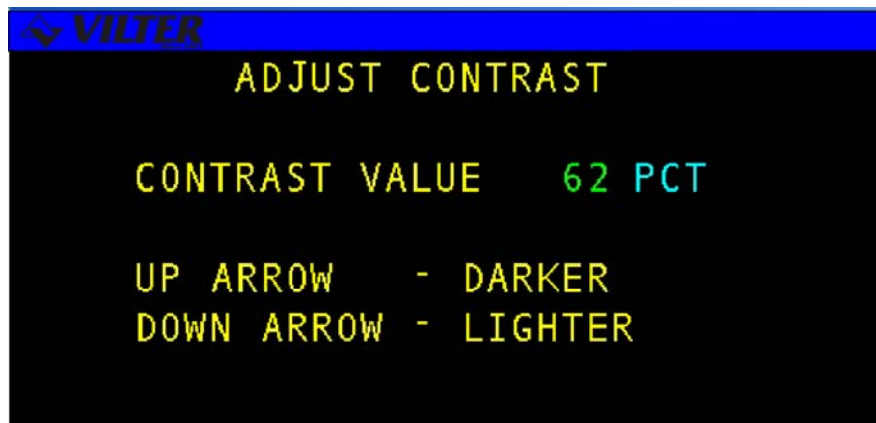

Adjust Contrast Screen

## Variable Frequency Drive Option

When VFD is enabled, a Proportional-Integral-Derivative (PID) algorithm is used to generate a 4-20mA control signal to the VFD. The VFD in turn varies the frequency and voltage to the motor resulting in slower or faster speeds.

The VFD option will only work when the option is enabled and the VFD single channel analog output board (VPN-3400G) is connected to the microprocessor board. The analog output card is to be placed on the microprocessor board towards the left-center, by four black “holes” and there is a connector labeled “J5 ANALOG OUTPUT.”

The VFD is enabled by pressing the “Menu” key then press the number 4 for “System Setup” then press number 5 for “Configure Hardware” and then press number 5 for “Control Configuration”. After enabling the VFD option, the configuration of the VFD can be located by pressing the “SETPT” key then press number 4 for “Capacity Control” and then press number 2 for “Motor Speed.”

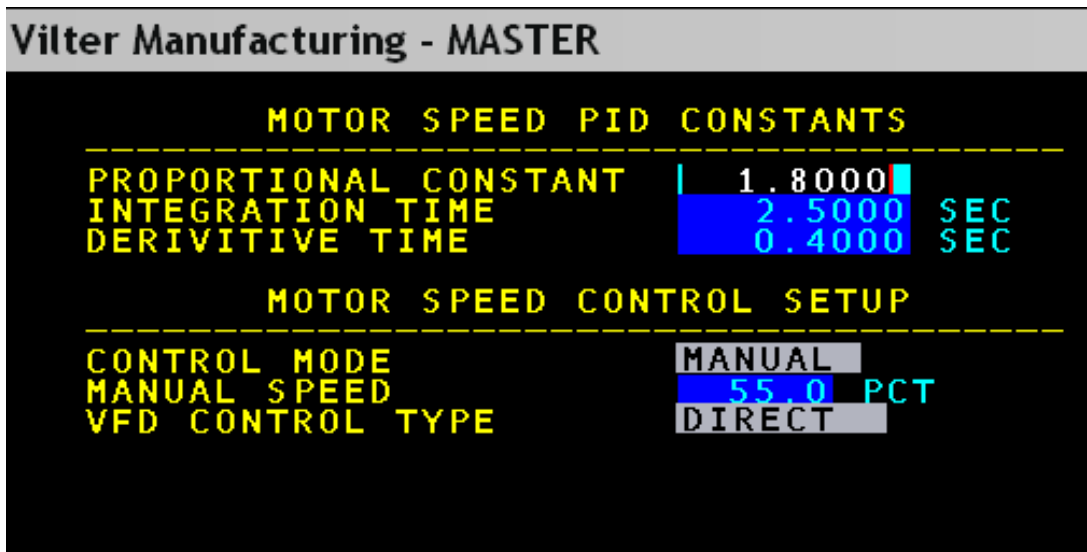

**Motor Control Screen**

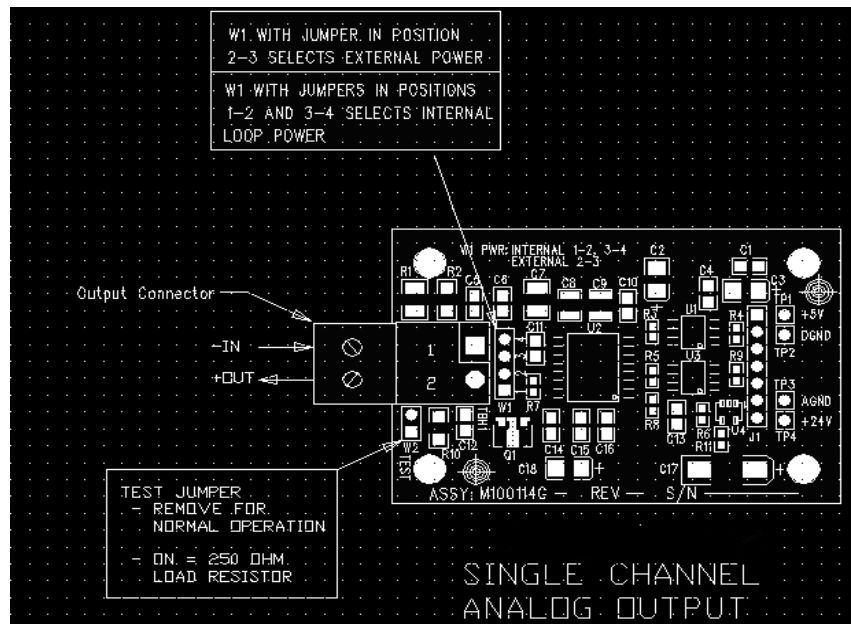

VFD Single Channel Analog Output Card and Jumper Settings.

Definitions of the terms used in the Motor Speed screen.

<u>Term</u>	<u>Definition</u>	<u>Range</u>
Proportional Constant	Adjusts the speed based on how far the control parameter currently is from the control setpoint. A higher P term causes a greater speed changes when far from the setpoint.	0:1000
Integration Time	Adjusts speed based on how rapidly the control parameter should approach the setpoint. A higher I term causes a slower approach to the setpoint when the control parameter is not changing.	0:1000 sec
Derivative Time	Adjusts the speed based on the past value of the control parameter. A large D term may result in large fluctuations in the speed. Care must be taken to keep D as low as possible.	0:1000 sec
Control Mode	The control for the VFD. Automatic lets the VILTech select proper speed.	Automatic/Manual/Tuning
Manual Speed	The VFD speed when Manual mode is selected.	50-100 PCT
VFD Control Type	The 4-20mA control signal may be set to direct or reverse. When set to Direct, 4mA is low speed and 20mA is high speed. When set to Reverse, 20mA is the low speed and 4mA is high speed. This control is useful for testing purposes.	Direct/Reverse

## Sequencer Control

The control function is responsible for the management of a group of compressors to control a refrigeration load. The following sections will present the user with both a technical overview and the operating procedures for sequencer control.

### Sequencer Technical Section

In a typical refrigeration system several compressors may be used to provide the required tonnage to control the refrigeration load. If the load is high all compressors may be needed. If the load is low only one compressor may be needed. The sequencer automatically manages the starting and stopping of the compressors to maintain the system control parameter at the desired setpoint. This process of starting and stopping compressors is referred to as staging up or down compressors.

The order that the compressors are staged is defined by the operator in a lead list. The sequencer makes decisions based on operator defined parameters and delay times which can be tailored to match the needs of the refrigeration system. The sequencer continuously transmits the setpoint and system control parameter values to each compressor.

When a compressor is started by the sequencer it attempts to maintain the system control parameter at the defined setpoint using its own automatic capacity control. The compressor that is making capacity adjustments in response to load changes is referred to as the “Trim Machine.” Once the trim machine is fully loaded it informs the sequencer that it can no longer increase capacity. If the load is still not under control the sequencer will inform the trim machine to lock at full capacity and will start another compressor, if one is available. The newly started compressor is now the trim machine. This process will continue until the load is under control or all compressors have been utilized. If the load decreases to the point where the trim machine is no longer needed it will be stopped and control is passed back to the previous compressor.

The staging up and down of compressors will be performed at different rates based on the difference between the system control parameter and the setpoint. If the difference is large, fast staging is performed. If the difference is small, normal staging is performed. This staging technique ensures that compressors are started when needed and at the same time minimizes any unnecessary starting or stopping. Independent sets of operator defined parameters are provided for both the loading and unloading conditions.

The refrigeration control may contain multiple sequencers depending on the configuration of the refrigeration system. For example, if booster compressors are used to maintain one suction pressure level and high stage compressors maintain a second pressure level the system would use two different sequencers. In many refrigeration systems a compressor may be piped such that it can be used on more than one refrigeration load, this is referred to as a swing machine. For example, using hand valves the operator can configure a compressor as a booster or a high stage machine. This swing machine would be available to both the high stage and booster sequencers.

The sequencer allows a group of compressors to be used in an efficient manner without operator intervention. The automatic starting and stopping of compressors ensures that power requirements and operational costs are kept to a minimum.

## Sequencer System Control Parameters

A sequencer uses a sensor value and compares this value to an operator defined setpoint to control the refrigeration load. This system control parameter may be a suction pressure, a process temperature or any other reading that provides an accurate indication of the required refrigeration load.

## Sequencer Staging Control

The sequencer starts and stops compressors based on operator defined parameters. Independent parameters may be defined for loading and unloading conditions. The control parameters described below are modified using the sequencer setpoints and sequencer control group select screens.

**Control Setpoint** - The control setpoint defines the desired level for the system control parameter. The sequencer will take action based on the difference between the system control parameter and the setpoint. The setpoint value is also transmitted to the compressors to be used in automatic capacity control while in the sequence mode.

**Control Deadband** - The load and unload deadbands define a zone around the control setpoint where no staging actions will be taken. If the difference between the setpoint and the system control parameter is less than the load or unload deadband, no staging will be performed. The deadband values for loading and unloading are transmitted to the compressors to be used in automatic capacity control while in sequenced mode.

**Normal Bandwidth** - The load and unload bandwidths are used to define the difference between normal staging and fast staging. If the difference between the system control parameter and the setpoint is outside the deadband but within the bandwidth the normal stage delay is used. If the difference is greater than the bandwidth the fast stage delay time is used. The normal bandwidth values for loading and unloading are transmitted to the compressors to be used in automatic capacity control while in sequenced mode.

**Normal Stage Delay** - The load and unload normal stage delays are used to reduce unnecessary compressor stops or starts. The sequencer will delay this amount of time before taking action when the difference between the system control parameter and the setpoint is outside the deadband but within the bandwidth and the trim machine is fully loaded. Setting the normal stage delay to zero will disable normal stage delay staging.

**Fast Stage Delay** - The load and unload fast stage delays are used to allow quick action to be taken when the system control parameter is far above or below the setpoint. The sequencer will delay this amount of time before taking action when the system control parameter is outside the bandwidth.

The relationship of these parameters can be seen in the sequencer control strategy diagram shown below.

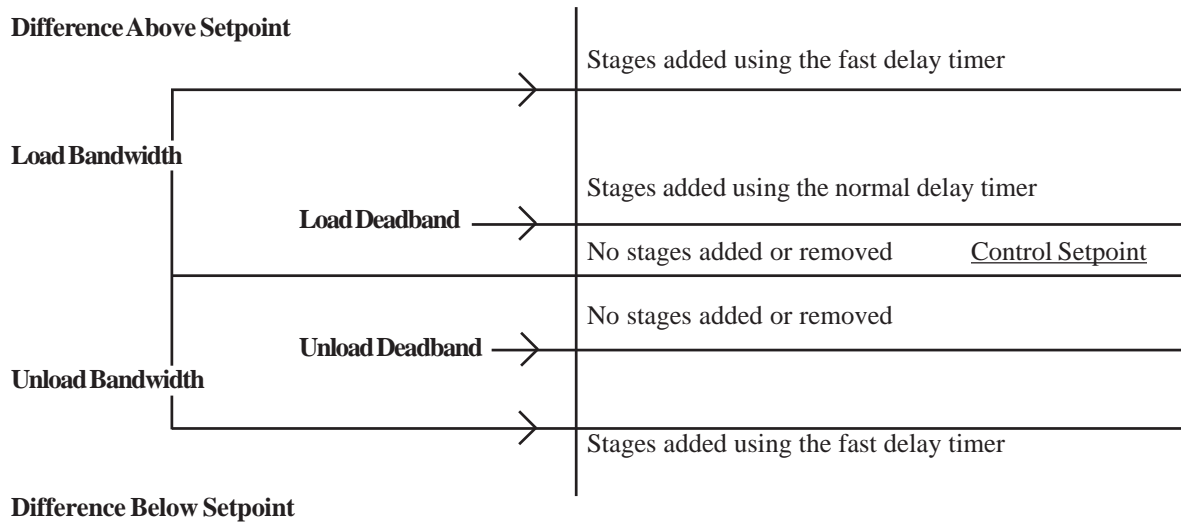

## Sequencing Commands      Sequencer Control Strategy

The sequencer controls compressors by sending sequencing commands. These commands are transferred locally to compressors on the master or via the communications link to remotes. The commands and their function are as follows:

**SEQUENCE STOP**- The SEQUENCE STOP command is sent to cause a compressor to form an automatic stop. The compressor remains on-line and available for the next sequencer operation. If the anti-recycle timer on the compressor has not expired, the compressor will continue running in the Hot Standby state at zero percent capacity.

**TRIM**-The TRIM command is sent to the compressor that has been chosen to become the trim machine. This compressor will make capacity adjustments to control the load using automatic control. If the compressor is stopped and on-line, the TRIM command will perform a sequenced start. Bandwidths and deadbands are sent to a compressor when the TRIM command is sent. Also, all time proportional control parameters are transferred to recip compressors with this command.

**FULL LOAD** - When FULL LOAD is received, a compressor will adjust to full capacity and hold that condition. If a compressor is stopped and on-line, the FULL LOAD command will perform a sequenced start.



## System Control Parameter and Setpoint Communication

The sequencer continuously sends the setpoint and system control parameter to all the compressors in its lead list. Sending the setpoint eliminates the need to setup every compressor individually and allows the sequencer to schedule setpoint changes. Sending the system control parameter eliminates any piping losses and assures that all compressors are working towards the same goal. When a compressor is using the sequencer setpoint and control parameter the setpoint will be displayed and the setpoint group label will be displayed as “SY.”

## Sequencer Operations

The current operational status of a sequencer is displayed on the sequencer status page. The sequencer may be in any one of the following states :

**DISABLED** -The sequencer has been disabled and no staging will be performed.

**HOLDING** -The sequencer is enabled and the system control parameter is currently within the deadband.

**DECREASING** -The sequencer is enabled and the system control parameter is below the unload deadband. Stages will be removed based on the stage delay timers.

**INCREASING** -The sequencer is enabled and the system control parameter is above the load deadband. Stages will be added based on the stage delay timers.

## Sequencer Lead List

The compressors available to a sequencer and the order in which they are to be used are defined in the sequencer lead list. The operator can modify the lead list from the sequencer lead list screen. The total list of compressors available to the sequencer is pre-defined based on the piping of your refrigeration system.

### Unused Compressors in the Lead List

If the operator determines that a particular compressor should not be used, a NONE may be selected in any of the lead list slots.

### Swing Machines

In many refrigeration systems a compressor may be piped such that it is allowed to be used on more than one refrigeration load. For example, using hand valves the operator may configure a compressor as a booster or a high stage machine. In such a system this swing machine may be available to two separate sequencers. The operator should take precautions to ensure that the name of the swing machine appears in only one sequencer lead list.

## **Lead list Processing**

The sequencer processes through the lead list starting and stopping compressors as required. Lead list changes, unavailable compressors, or a failure on one or more machines will cause special processing to be performed. This special processing is described in the following sections:

### **Lead List Changes**

When the operator changes the sequencer lead list, no compressors will be stopped or started immediately. Instead, the compressors will be re-ordered and the last running compressor in the lead list will be given a Trim command. The trim machine in the previous lead will be given a Full Load command. The standby monitor timer is then started. When the standby monitor timer expires, the first compressor in Standby which is above the new trim machine will be started with the Full Load command. The standby monitor timer will then be restarted. The sequencer should now find a new operating condition which may result in the current trim machine stopping. This process continues until all Standby machines above the trim machine are started.

### **Unavailable Compressors**

If a compressor in the lead list is not available when required it will be skipped and the next available machine will be started. If the skipped compressor then becomes available it will be started immediately using the Full Load command. The standby monitor timer will then be started, allowing the new configuration to find its proper operating point. This process of starting a skipped compressor automatically maintains all running compressors in the lead list order. It should be noted that a compressor becomes unavailable any time it is stopped locally, not in sequenced mode or failed.

### **Trim Machine Failures**

If the trim machine fails making it unavailable, two different scenarios can occur depending on the number of compressors running. If the trim machine was the only compressor running the next available compressor in the lead list is started immediately. If fully loaded compressors exist the previous compressor in the lead list becomes the trim machine. Additional compressors may then be started using the normal staging process.

### **Fully Loaded Machine Failures**

If a fully loaded machine fails making it unavailable, no immediate action is taken. Additional compressors will be added through the normal staging process.

## **Sequencer Actions After Power Failures**

After a power failure to the master, the sequencer will send a sequence stop command to all compressors in its lead list. The compressors will be restarted using the normal staging process. Compressors that have failed because the power was off for more than their power fail reset time will be off-line and unavailable for sequencing.

### Sequencer Status

Every compressor in a sequencer's lead list is assigned a sequencer status which can be viewed on the sequencer status page. The following list describes the possible status conditions. :

**UNAVAIL** -The compressor is not available to the sequencer.

**STANDBY** -The compressor is available to the sequencer. This compressor may be stopped and on-line or be running with time remaining on its anti-cycle timer.

**LOADED** -The compressor is running and has been told to stay fully loaded

**TRIM** -The compressor is running and is the trim machine.

**HOTSTBY** -The Hot Standby state occurs when the compressor is running at zero percent capacity due to time remaining on its anti-recycle timer. This compressor is available to be restarted immediately if required by the sequencer.

**FRCTRIM** -The Force Trim state is an optional state used in two-stage refrigeration systems. If the booster sequencer needs a compressor to start but none of the high stage machines are currently running, the lead compressor in the high stage lead list will be forced to start and run.

**NO HSTG** -The No High Stage state is an optional state used in two-stage refrigeration systems. If the booster sequencer needs a compressor to start but all of the high stage machines are failed or off-line, the booster compressors will not be allowed to start.

### Compressor Availability

The sequencer is continuously checking the status of all compressors in its lead list to determine their availability. Unavailable compressors are marked with a sequencer status of UNAVAIL and are skipped when sequencer actions are taken. A compressor must meet the following conditions to be available to a sequencer:

**COMMUNICATION WITH THE MASTER** -The communications between the master and the panel controlling the compressor must be operational. Compressors being controlled locally by the master are not affected by communications.

**SEQUENCED MODE** -The compressor must be in sequenced mode.

**ON-LINE** -The compressor must have been placed on-line for sequenced operation.

**NO TIME REMAINING ON THE ANTI-CYCLE TIMER** -If the compressor is stopped with time remaining on the anti-cycle timer it will not be allowed to start. Therefore it is unavailable for sequenced operation.

**NO FAILURES** -A failure takes a compressor off-line and makes it unavailable for sequenced operation.

When a compressor determines that it can no longer make capacity adjustments to reduce the system control parameter it informs the sequencer that it is fully loaded. Compressors are fully loaded when all of their stages are in use.

## **Enabling and Disabling the Sequencer**

Each sequencer can be enabled or disabled from the sequencer control screen. When a sequencer is enabled or disabled, all available compressors in the lead list will be sent a sequence stop command. If it is desired that the compressors continue running, it is suggested that their mode be changed to AUTO before the sequencer is disabled.

## **Sequencer Control Groups**

A sequencer allows the operator to define up to four different control groups for the system control parameter. Each control group consists of a control setpoint, a low alarm setpoint and a low failure setpoint. All four control groups can be modified using the control group select screen.

## **Sequencer Setpoint Scheduling**

Sequencer setpoint scheduling is the automatic switching of control groups based on time of day and day of the week. Control setpoint groups and the selected lead list can be changed using scheduling. The operator can define up to seven (7) different daily time schedules and one weekly schedule. Sequencer scheduling can be enabled or disabled by the operator. All schedule changes are relayed to the compressors and take effect automatically.

### **Daily Schedules**

Each daily time schedule consists of up to eight (8) different time of day slots. For each time of day slot the operator can define the time, desired setpoint group number, and the desired lead list. Unused time slots are ignored and the schedule may be entered in any order. When the schedule is saved it is reordered chronologically. Each daily schedule is identified by a schedule name (SCH1 - SCH7)

### **Weekly Schedule**

The weekly schedule allows the operator to assign different daily schedules to each day of the week. A new day begins and schedules change at midnight. The sequencer weekly schedule is found on the schedule setup screen.

### **Enabling / Disabling Scheduling**

The operator may enable or disable setpoint scheduling from the schedule setup screen. When scheduling is enabled the setpoints are changed to match those defined by the schedule. When scheduling is disabled the setpoints must be changed manually.

### Overriding Schedule Actions

Using the schedule setup screen the operator can temporarily override scheduling actions. The active lead list, active schedule, and active group can be changed. Overrides may be altered after a schedule change occurs but may only last until the next scheduled activity occurs.

### **Alarm and Failure Setpoints**

The control parameter used to sequence compressors is monitored by the Viltech for alarm processing. High alarm and high failure setpoints can be defined by the operator using the high alarm setpoint screen under the SEQ hot-key. Low alarm and failure setpoints are set on the control group select screen and can be changed using scheduling.

### **Setting Up VILTech Panels for Sequencing**

Sequencing can be done using up to 8 VILTech panels. The VILTech panels are connected using a daisy chain wired to COMM 0 in the VILTech panels, as shown in wiring diagram 682017. Each compressor in the sequence must have the Sequence Option enabled in the “Control Configuration” screen that is found by pressing the “Menu” hot key then press number 4 for “System Setup” then press number 5 for “Configure Hardware”. Now setup the safety setpoints for each compressor. Next, the Dip switches on the microprocessor board must be configured for the master and trim (slave) VILTech panels. The master VILTech panel will have the 8<sup>th</sup> dip switch in the “ON” position, this identifies the panel as the master, and the rest of the dip switches will identify to the master how many trim panels are in the sequence by putting the dip switch in the “ON” position for the correct binary sum value that corresponds to that number of trim panels. Then the dip switches on the trim panels must be set up sequentially in the order that each will turn on by the command of the master. For example, if there is a master and 3 trim compressors then dip switch 1, 2, and 8 are in the “ON” position and the trim compressors will have their own unique address starting with 1. Shown below is a chart on how this example would be set up. (If there are more than 4 trim panels then those would be set up like it is shown below.)

Binary Value	1	2	4	8	16	32	64	
Dip Switch	1	2	3	4	5	6	7	8
Master	on	on	off	off	off	off	off	on
Trim 1	on	off	off	off	off	off	off	off
Trim 2	off	on	off	off	off	off	off	off
Trim 3	on	on	off	off	off	off	off	off
Trim 4	off	off	on	off	off	off	off	off
Trim 5	on	off	on	off	off	off	off	off
Trim 6	off	on	on	off	off	off	off	off
Trim 7	on	on	on	off	off	off	off	off

Now on the master panel the ON/OFF switch on the I/O board can be used to reboot the microprocessor. Next press the SETPT key and press the number 6 for Sequencer. On the Sequencer screen, the Control screen has the enable, disable, and automatic options. Disabling the sequencer will not allow the master to communicate with the other trim panels even if the “SEQ” key is pressed. Enabling the sequencer will allow the master to communicate with the trim compressors when the “SEQ” key is pressed. Now if the sequencer control is put to Automatic then a remote signal tied into channel 12 will start/stop the master panel and then it will automatically control the other trim panels according to capacity needs. When all the setpoints are configured then the panels can be put on-line by pressing the “SEQ” button in the Mode section of the keypad.

## Sequencer Operating Procedures

The sequencer function will use a SEQ hot key to allow the operator to adjust the controls for the various sequencers contained in the system. The following sections describe the various procedures used in the sequencer function.

### Sequencer Status Screen

The presence of a SEQ hot key will add at least one sequencer status screen to the list of status screens. The extra status screen appears when the user scrolls through the system status screens. Below is an example of a sequencer status screen. Multiple sequencer status screens may be present depending on the systems configuration.

VILTER						
LT SEQUENCER STATUS						
SEQUENCE OPERATION	SUCTION PRESS	GROUP	SETPOINT	LEAD LIST		
HOLDING	00:00	9.0 PSIG	S1	10.0 PSIG	A 00:00	
LEAD LIST	COMPRESSOR	STATUS	CAPACTY	MODE	STATE	ANTICYCLE
LEAD	SCREW 1	TRIM	95 PCT	SEQ	RUN TRIM	00:00
2ND	FECIP	STANDBY	0 PCT	SEQ	STOP ONLINE	00:00

### Sequencer Status Screen

The following table lists the data entry and information fields on the screen and a description of their purpose.

TERM	DEFINITION
<b>SEQUENCE OPERATION</b>	The state of the sequencer (DISABLED, DECREASING, INCREASING, HOLDING). Also shows the value of the staging timer.
<b>SUCTION PRESS</b>	The current value of the system suction pressure for system process temperature.
<b>GROUP</b>	Shows the current control group being used.
<b>SETPOINT</b>	The current setpoint value utilized by the sequencer. Engineering units will change to DEGF if Process Temperature is being used.
<b>LEAD LIST (Status)</b>	Shows the currently selected lead list number and the value of the standby monitor timer.
<b>LEAD LIST (Heading)</b>	Shows the current order of compressors in the lead list.
<b>COMPRESSOR</b>	Shows the names of the compressors in the lead list.
<b>STATUS</b>	The current sequencer status of the compressors (UNAVAIL, STANDBY, FULL LOAD, TRIM, HOTSTBY).
<b>MODE</b>	The current mode of each compressor.
<b>STATE</b>	The state of each compressor.
<b>ANTICYCLE</b>	The time remaining on each compressor's anti-cycle timer.

## SEQ Hot Key

Following is a menu diagram for the SEQ hot key. This menu diagram is for a system with only one sequencer. If the system has more than one sequencer, multiple sequencer setup selections will be available. Additional menu selections for control setpoints, control groups, and high alarm setpoints are present if the system contains multiple system control parameters.

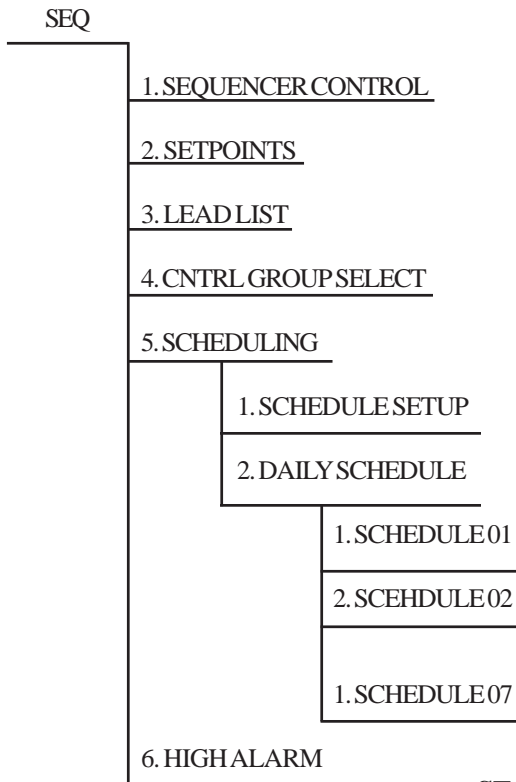

**SEQ Menu Diagram**

### Sequencer Control

The sequencer control screen allows the operator to enable or disable the sequencer. If process temperature is an option, it may also be selected from this screen.

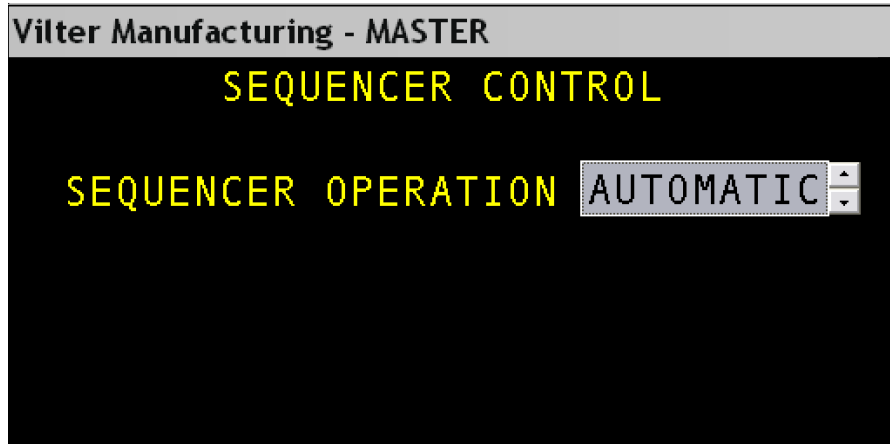

**Sequencer Control Screen**

### Sequencer Setpoints

On the next page is an example of a sequencer control setpoints screen. If the sequencer can use multiple system control parameters, a menu will allow selection of control setpoints for each parameter.

The standby monitor timer is used to limit compressor starts after lead list changes or when previously failed compressors are brought back on-line. The Sequencer Control Setpoints screen is divided into four areas. The Sequencer Controls section at the top controls how the sequencer decides when to start or stop compressors. The Compressor Controls section in the center is passed to the Trim Compressor to allow it to load and unload at a different rate than the Sequencer. At the bottom of the screen is the Standby Monitor timer and an optional setpoint for use in two-stage refrigeration systems. The Reference Data on the right is dynamically updated while the user is changing setpoints.





LT SEQUENCER  
CONTROL SETPOINTS

	LOAD CONTROLS		UNLOAD CONTROLS		REFERENCE DATA
NORMAL BANDWIDTH	10.0	PSID	10.0	PSID	SYSTEM SUCTION PRESS
CONTROL DEADBAND	1.0	PSID	1.0	PSID	8.4 PSIG
NORMAL STAGE DELAY	10.0	MIN	10.0	MIN	
FAST STAGE DELAY	1.0	MIN	1.0	MIN	SYSTEM CONTROL SETPT S1
					24.7 PSIG

STANDBY MONITOR TIMER 3.0 MIN

### Sequencer Control Setpoints Screen

The following table lists the data entry fields and a description of their purposes. The ranges for these parameters will vary based on the type of system control parameter used.

PARAMETER	DEFINITION	RANGE
<b>SEQ NORMAL BANDWIDTH</b>	The sequencer load and unload normal bandwidth define when normal staging stops and fast staging begins. If the difference between the setpoint and system control parameter is greater than the bandwidth fast staging is performed.	0 - 20 PSID
<b>SEQ CONTROL DEADBAND</b>	The sequencer load and unload control deadbands define a zone around the setpoint where no staging action will be taken.	0 - 20 PSID
<b>SEQ NORMAL STAGE DELAY</b>	The sequencer normal stage delay is used to add or remove stages when the difference between the system control parameter and the setpoint is outside the deadband but within the normal bandwidth. Entering a zero for the load or unload normal stage delay time disables staging under these conditions.	0 - 99 MIN
<b>SEQ FAST STAGE DELAY</b>	The sequencer fast stage delay is used to add or remove stages when the difference between the system control parameter and the setpoint is outside the normal bandwidth.	0.1 - 10 MIN

### Sequencer Control/Setpoints Screen Definitions

<b>PARAMETER</b>	<b>DEFINITION</b>	<b>RANGE</b>
<b>COMP NORMAL BANDWIDTH</b>	The compressor load and unload normal bandwidth define when the compressor will increase or decrease capacity. If the difference between the setpoint and system control parameter is greater than the bandwidth the compressor will load or unload continuously.	0 - 20 PSID
<b>COMP CONTROL DEADBAND</b>	The compressor load and unload normal deadband define a zone around the setpoint where no loading or unloading will be performed.	0 - 20 PSID
<b>STANDBY MONITOR TIMER</b>	The standby monitor timer is used to limit compressor starts after lead list changes or when previously failed compressors are brought back on-line.	0.1 - 99.9 MIN
<b>HSTG SUCT PRESS MIN SETPT (OPTION)</b>	This optional parameter may be used in the Booster stage of two-stage refrigeration systems. The High Stage Suction Pressure Minimum Setpoint is used to ensure that the Suction Pressure of the High Stage compressors is below a minimum value before a Booster compressor is allowed to start.	29.9 INHG – 185.3 PSIG

**Sequencer Control/Setpoints Screen Definitions (Continued)**

**Lead List**

The sequencer lead list defines the order that the compressors will be added or removed. The “NONE” selection is used to allow the operator to remove a compressor from the lead list. The user should make sure no duplicate entries exist in the lead list and that no two sequencers contain the same compressor at the same time. Two lead lists are now provided as a standard in most new control systems. Lead List A or B may be selected manually or scheduled along with the sequencer control setpoint.

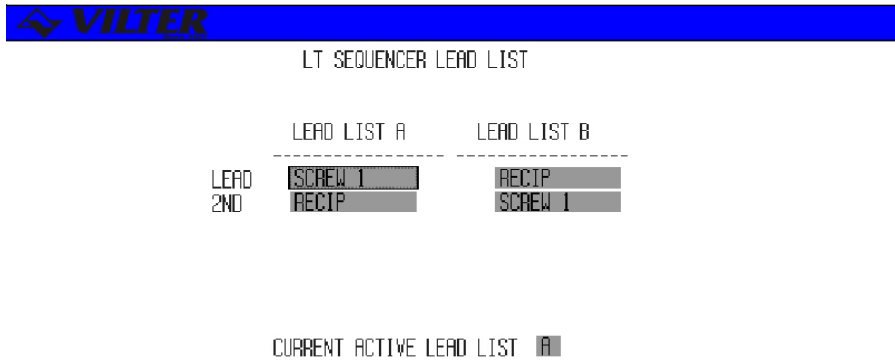

**Sequencer Lead List Screen**

The following table lists the various parameters displayed on the sequencers lead list screen.

TERM	DEFINITION	RANGE
<b>LEADLISTA</b>	The order of compressors in the A lead list.	Selectable
<b>LEADLISTB</b>	The order of compressors in the B lead list.	Selectable
<b>CURRENTACTIVE LEADLIST</b>	Allows the user to select the Lead List to be used by the sequencer. The new lead list will effect when the screen is saved.	Selectable

**Sequencer Lead Screen Definitions**

## Control Group Select

The sequencer control group select screen permits the user to set the control, low alarm, and low failure setpoints for the different control groups. Below is an example of a sequencer control group select screen. If the sequencer contains multiple system control parameters, a menu will allow selection of control groups for each parameter.

	GROUP 1	GROUP 2	GROUP 3	GROUP 4
CONTROL SETPOINT	10.0 PSIG	10.0 PSIG	10.0 PSIG	10.0 PSIG
LOW ALARM	10.0 INHG	10.0 INHG	10.0 INHG	10.0 INHG
LOW FAILURE	15.0 INHG	15.0 INHG	15.0 INHG	15.0 INHG

CURRENT ACTIVE GROUP NUMBER **51**

### Sequencer Control Group Select Screen

The following table lists the various parameters displayed on the sequencer suction pressure control group select screen. The range of these parameters will vary depending on the type of system control parameter used.

TERM	DEFINITION	RANGE
<b>CONTROL SETPT</b>	The sequencer will add or remove compressors to maintain the system control parameter at this control setpoint.	29.9 INHG-185.3 PSIG
<b>LOWALARM</b>	An alarm is activated when the system control parameter is below this value.	29.9 INHG-185.3 PSIG
<b>LOWFAILURE</b>	A failure is activated when the system control parameter is below this value.	29.9 INHG-185.3 PSIG

### Sequencer Control Group Select Definitions

## Schedule Setup

The schedule setup screen is used to enable/disable scheduling along with setting the weekly schedules and performing scheduling overrides. An example of a schedule setup screen is shown below.

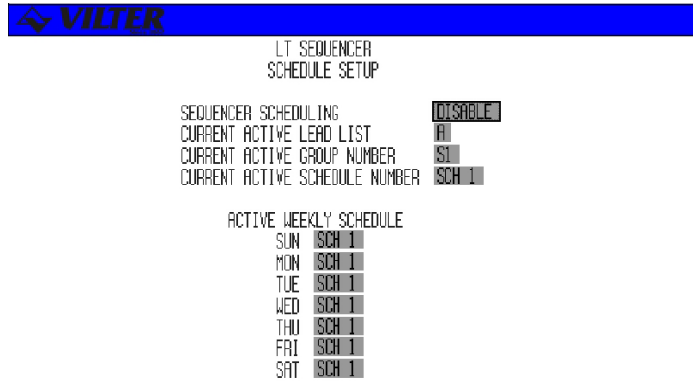

### Sequencer Schedule Setup Screen

The following table lists the various parameters displayed on the master sequencer setup screen.

TERM	DEFINITION	RANGE
<b>SEQUENCER SCHEDULING</b>	Enables or disables scheduling.	Selectable
<b>CURRENTACTIVE LEAD LIST</b>	Overrides the current active lead list.	Selectable
<b>CURRENTACTIVE GROUP#</b>	Overrides the current active group.	Selectable
<b>CURRENTACTIVE SCHEDULE#</b>	Overrides the current active schedule.	Selectable
<b>WEEKLY SCHEDULE</b>	Allows one of the seven daily schedules to each day of the week.	Selectable

### Sequencer Schedule Setup Screen Definitions

**Daily Schedules**

The daily schedules are reached by entering the schedule number on the schedule access screen. Below is an example of a daily schedule screen.

VILTER			
LT SEQUENCER			
DAILY SCHEDULE 2			
EVENT NUMBER	SCHEDULED TIME	SELECTED SP GROUP	SELECTED LEAD LIST
1	08:00 AM	S1	A
2	09:00 AM	S1	B
3	11:15 AM	S3	A
4	12:00 AM	S1	A
5	02:30 PM	S2	B
6	05:00 PM	S1	A
7	08:00 PM	S1	A
8	1--:--AM	S1	A

**Sequencer Daily Schedule Screen**

The following table lists the data entry fields and description of their purposes.

TERM	DEFINITION	RANGE
<b>SCHEDULED TIME</b>	The time schedule change will take place (entered in 12 or 24 hour mode.)	Valid Time of Day
<b>SELECTED GROUP</b>	The control group number to be used at this time.	Selectable
<b>SELECTED LEAD LIST</b>	The lead list to be used at this time.	Selectable

**Sequencer Daily Schedule Screen Definitions**

### High Alarm

The high alarm setpoints screen allows the operator to adjust the high alarm and failure setpoints. If the sequencer supports multiple system control parameters, a menu will allow selection of high alarm setpoints for each parameter. An example of the high alarm setpoints screen is shown below.

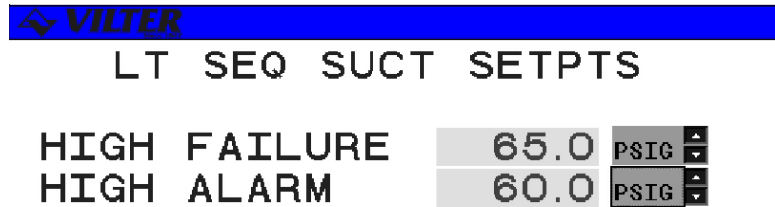

### SequencerHigh Alarm Screen

The following table lists the data entry fields and description of their purposes.

TERM	DEFINITION
HIGHFAILURE	If the system control parameter is above this value, a failure will be reported.
HIGHALARM	If the system control parameter is above this value, an alarm will be reported.

### Sequencer High Alarm Screen Definitions

**Addendum for Pump Down Program for VILTech**

The VILTech needs to be setup for Remote operation, Auto Start/Stop enabled, and Suction Pressure control. The Process Temperature control is not an option for capacity control and is used instead to control the Chiller Liquid Valve.

When the controller is On-Line, the Remote Start/Stop input energizes, and the Process Temperature input is above the High Temperature Cut-In setpoint; the Chiller Liquid Valve will be opened. Then when the Chiller Liquid Valve is open and the Suction Pressure rises above the Cut-In setpoint, the compressor starts.

*Note: that if the Process Temperature is not above the High Temperature setpoint or if the compressor is not On-Line, the Chiller Liquid Valve will not be opened and the compressor will not start even if the Suction Pressure is above the Cut-In setpoint.*

As long as the Process Temperature remains above the Low Temperature setpoint, the compressor will load, unload, cut-out, and cut-in normally based on the Suction Pressure control setpoints. If the Process Temperature falls below a Low Temperature setpoint, the Chiller Liquid Valve will be closed and the compressor should pump down and shutoff normally when the Suction Pressure falls below the Cut-Out setpoint. But if the Remote Start/Stop input is de-energized, the Liquid Valve will be closed right away but the compressor will be allowed to pump down and shutoff normally when the Suction Pressure falls below the Cut-Out setpoint.

Other operations are still allowed like Automatic operation is permitted when using the AUTO button on the panel. In this case, operation is the same except that the Remote Start/Stop input is ignored. Manual operation is permitted when using the MAN button on the panel. In this case, the compressor starts and the Chiller Liquid Valve opens and closes normally with temperature but none of the time delays, cut-in, cut-out, or automatic capacity controls are used. Manual capacity control is available.

A user-programmable time delay will be started anytime the compressor starts to prevent the compressor from stopping due to the Cut-Out setpoint or a Low Suction Pressure Failure. The default time delay is 90 seconds should be varied with each application. For example, when using glycol, this time delay can be shortened to 5 seconds or less. High and Low Suction Pressure alarms and failures will remain inhibited for the time delay period and when the compressor is stopped.

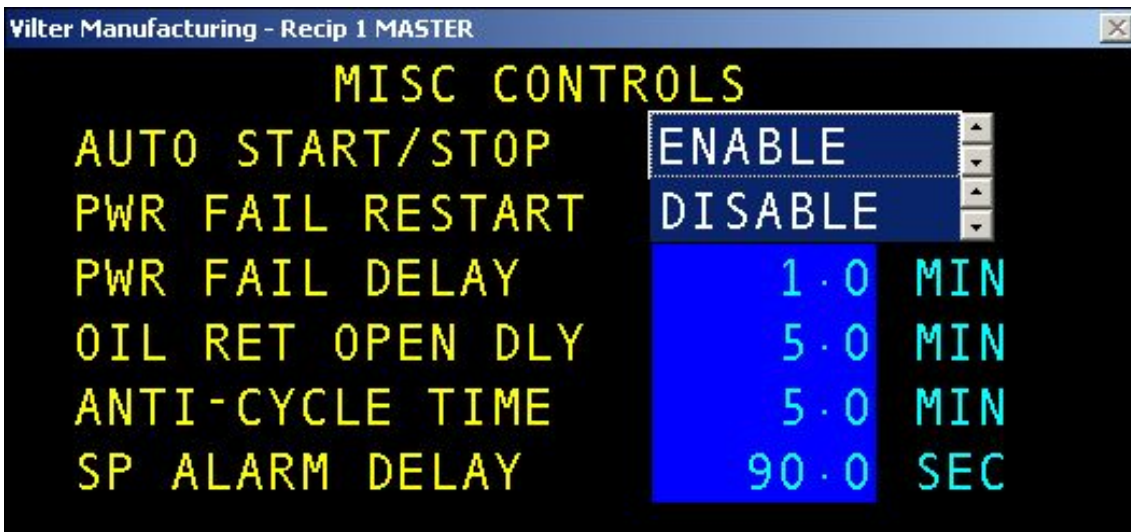



The Process Temperature Cut-In/Cut-Out setpoints used for control are taken from the setpoint group associated with the current Suction Pressure control group. For example, if Suction Pressure Group 2 is currently selected for control, the Process Temperature setpoints will also be taken from Group 2.

The following Hardware needs to be installed for the Pump Down program to function:

- Process Temperature input (Analog Channel 8) is the Alcohol Temperature from another control system.
- The Remote Start/Stop input from DCS is used to control enabling/disabling the process when the RMT button on the panel is used to start the process.
- Spare I/O Channel 16 will be fitted with a solid state output module to control the Liquid Valve.
- Software for the Pump Down Program installed.



## APPENDIX A

# *Alarm and Failure Data*

The Alarm and Failure Data Appendix provides a table which describes all of the analog and discrete alarms in the system. The level column describes the type of alarm or failure and the Default column lists the factory setpoint for analog alarms.

### Analog Alarms

No.	Parameter Name	Level	Default	Comments
1.	High Suction Pressure	Fail	70 PSIG	
2.	High Suction Pressure	Alarm	50 PSIG	
3.	Low Suction Pressure	Alarm	28 PSIG	
4.	Low Suction Pressure	Fail	29.9 PSIG	
5.	Low Suction Pressure	OEM	29.9 PSIG	
6.	High Discharge Pressure	OEM		225 PSIG for NH3 275 PSIG for R22
7.	High Discharge Pressure	Fail		225 PSIG for NH3 275 PSIG for R22
8.	High Discharge Pressure	Alarm	215 DEGF	
9.	High Discharge Temperature	OEM	212 DEGF	
10.	High Discharge Temperature	Fail	212 DEGF	
11.	High Discharge Temperature	Alarm	200 DEGF	
12.	High Oil Temperature	OEM	180 DEGF	
13.	High Oil Temperature	Fail	155 DEGF	
14.	High Oil Temperature	Alarm	140 DEGF	
15.	Low Oil Pressure	Alarm	15 PSIG	
16.	Low Oil Pressure	Fail	10 PSIG	
17.	Low Oil Pressure	OEM	10 PSIG	
18.	Low Intermediate Temp(Two Stage) Spare(One Stage)	Fail	50 DEGF	
19.	High Process Temperature(Option)	Fail	50 DEGF	
20.	High Process Temperature(Option)	Alarm	45 DEGF	
21.	Low Process Temperature(Option)	Alarm	30 DEGF	
22.	Low Process Temperature(Option)	Fail	25 DEGF	
23.	High Intermediate Pressure(Two Stage) Spare(One Stage)	Fail	103 PSIG	
24.	High Intermediate Pressure(Two Stage) Spare(One Stage)	Alarm	58 PSIG	
25.	Low Intermediate Pressure(Two Stage) Spare(One Stage)	Alarm	45 PSIG	
26.	Low Intermediate Pressure(Two Stage) Spare(One Stage)	Fail	40 PSIG	

No.	Parameter Name	Level	Default	Comments
27.	High Intermediate Pressure (Two Stage) Spare (One Stage)	Alarm	58PSIG	
28.	Low Intermediate Pressure (Two Stage) Spare (One Stage)	Alarm	45PSIG	
29.	Low Intermediate Pressure (Two Stage) Spare (One Stage)	Fail	40PSIG	

## Discrete Alarms

No.	Parameter Name	Level	Comments
1.	Memory Initialized	Alarm	
2.	Frame Overrun	Alarm	
3.	Timer Allocation	Fail	
4.	RAM Size Failure Low	Fail	Indicates a hardware problem with the RAM Chip.
5.	Power Low Reset	Fail	The Power has drooped below a threshold but did not completely go away. A sensor or other device may be shorted
6.	Power Fail Reset	Fail	Power was lost
7.	Pushbutton Reset	Fail	The reset button on Main Board was pressed.
8.	Watchdog Reset	Fail	The Software was unable to complete it's cycle. May be communications or interrupt related.
9.	Operator Reset	Fail	Reset from a screen save from the keypad or PC
10.	Auxiliary Contact 1	Fail	Open to Fail
11.	Safety Circuit	Fail	
12.	Suction Pressure Sensor Bad	SNSR	
13.	Discharge Pressure Sensor Bad	SNSR	
14.	Oil Press Sensor Bad	SNSR	
15.	Discharge Temperature Sensor Bad	SNSR	
16.	Oil Temperature Sensor Bad	SNSR	
17.	Suction Temperature Sensor Bad	SNSR	
18.	Motor Current Sensor Bad	SNSR	
19.	Process Temperature Sensor Bad	SNSR	
20.	Intermediate Pressure Sensor Bad (Two Stage) Spare (One Stage)	SNSR	
21.	Intermediate Temperature Sensor Bad (Two Stage) Spare (One Stage)	SNSR	
22.	Spare		
23.	Spare		
24.	Spare		
25.	Spare		
26.	Motor Off/Current Normal/Aux Open	Fail	The Micro checks the state of the Motor Output and Aux Input. To verify correct operation Aux contact closed indicates the motor is running. If Motor is running when it should be off the Micro will take the following steps:(1) Failure signal is generated to alert operator: (2) Capacity is forced to a full unload condition.
27.	Motor On/Current Low/Aux Open	Fail	
28.	Motor On/Current Normal/Aux Open	Fail	
29.	Motor Off/Current Low/Aux Closed	Fail	
30.	Motor Off/Current Normal/Aux Closed	Fail	
31.	Motor On/Current Low/Aux Closed	Fail	
32.	Spare		
33.	Master Shutdown	Fail	The master has requested a shutdown

## APPENDIX B

# Analog and Discrete I/O

The Analog and Discrete I/O section identifies the channel assignments for sensor inputs, control outputs, and status inputs for various compressor models.

### Analog Inputs

RECIP Compressor-Analog Inputs					
TYPE	CHANNEL	NAME	RANGE	UNITS	SENSOR TYPE
Press	1	Suction Press	0: 200	INGH	4-20 mA
Press	2	Discharge Press	0: 500	PSIG	4-20 mA
Press	3	Oil Press	0: 500	INGH	4-20 mA
Well Temp	4	Discharge Temp	32: 392	DEGF	4-20 mA
Well Temp	5	Oil Temp	32: 392	DEGF	4-20 mA
Well Temp	6	Suction Temp	-58: 122	DEGF	4-20 mA
Press	7	Intermediate Press(Two Stage) Spare(One Stage)-DP2	0: 500	PSIG	4-20 mA
Well Temp	8	Process Temp or DT2	-58: 122	DEGF	4-20 mA

### Discrete I/O RACK 1

TYPE	CHANNEL	NAME	OFFSTATE	ON STATE	NOTES
Output	1	Compressor Motor	Off	On	
Output	2	Capacity Stage 1	Off	On	
Output	3	Capacity Stage 2	Off	On	
Output	4	Capacity Stage 3	Off	On	
Output	5	Capacity Stage 4	Off	On	
Output	6	Spare	Off	On	
Output	7	Spare	Off	On	
Output	8	Alarm/Failure	Norm	Alarm	
Input	9	Motor AUX	Open	Closed	1
Input	10	AUX Shutdown	Alarm	Norm	3
Input	11	Safety Circuit	Alarm	Norm	3
Output	13	Crank Case Heater	Off	On	
Input	12	Remote Start/Stop	Open	Closed	
Output	14	Oil Return Solenoid	Closed	Open	
Output	15	Cooling Control	Closed	Open	
Output	16	Spare	Closed	Open	

*Notes:*

- 1-Normally open contact with no power or level
- 2-Normally closed contact with no power or level
- 3-Normally closed contact open to fail
- 4-Energize for condition

- 5-De-energize for condition
- 6-Pilot driven-Energize to close
- 7-De-energize to turn via customer supplied relay



## APPENDIX C

# *Communication Protocols*

## Introduction

The hardware interface and software protocol are defined for performing serial communications with the Viltech using the Modbus RTU protocol. In this case, the implementation of the protocol is limited to the sub-set of the complete set of possible message types. Communications with one or more compressors is possible using a RS-485 or RS-422 multi-drop interface.

*NOTE: Modbus is a registered trademark of Modicon, Inc.*

Real time monitoring of the following data is provided:

- Analog input parameters
- Discrete I/O parameters
- Mode and State information
- Computed parameters
- Alarm Information

Real time control of the following parameters is provided:

- Compressor Control including start/stop and mode changes
- Compressor Capacity Control Setpoints

## **Applicable Documents**

Familiarity with the following documents is highly recommended:

- Modicon Modbus Protocol Reference Guide (PI-MBUS300)

## Hardware Interface Description

### Hardware Requirements

The Vilter 400 Series Compressor uses the on-board COMM 1 port for Modbus RTU communications. The hardware configuration for both protocols is 5-volt RS-485 or RS422 multi-drop.

### Interface Connections

Physical interface connections for Modbus communications are made at COMM 1 located on the left side of the main microprocessor board next to the corner. The following table shows the pin-outs for the Viltech hardware for COMM 1.

Pin	Name	Function
1	TX+	Transmit Data (Positive)
2	TX-	Transmit Data (Negative)
3	GND	Ground
4	GND	Ground
5	RX-	Receive Data (Negative)
6	RX+	Receive Data (Positive)

**NOTE:** For RS-485 communications, use Terminals 1 and 2 for the network connection and add a jumper between Terminals 1-6 and 2-5.

The use of low capacitance twisted/shielded cable is required (e.g. Belden #9503 or eq.). The shields should be grounded at the master computer end of the cable and floated at the microprocessor end.

Figure 1 shows the interface cabling connections for typical Modbus applications. Also shown are the recommended shield grounding requirements for an in-line data path and a split data path. Other controllers or PC configurations may be different.

**NOTE:** Since Modbus communications share a port with Viltech communications, The port must be selected for Modbus operation on the Communications Setup screen.



WIRING DETAIL FOR MODBUS MASTER TO ONE OR MORE COMPRESSORS

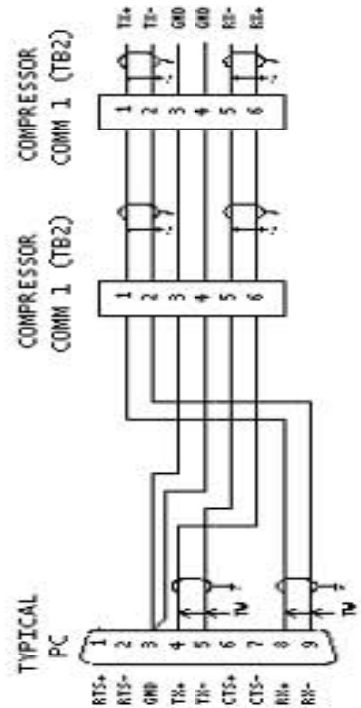

SHEILD GROUNDING DETAIL FOR INLINE DATA PATH (RECOMMENDED)

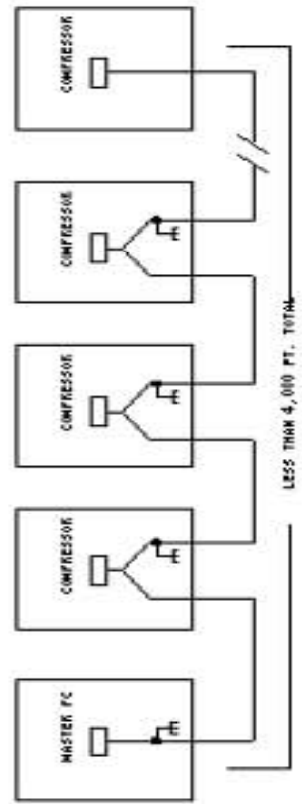

SHEILD GROUNDING DETAIL FOR SPLIT DATA PATH

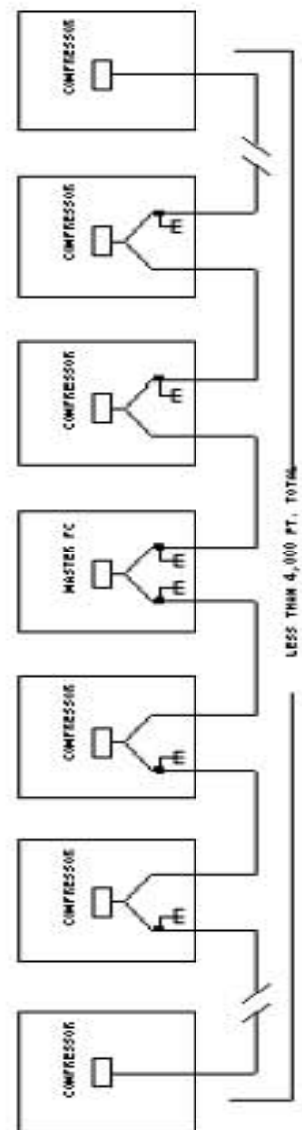

NOTES:

1. GROUND THE SHIELD DRAIN WIRE TO THE ENCLOSURE AT THE UPSTREAM END OF EACH CABLE. THE UPSTREAM END OF THE CABLE IS THE END NEAREST THE PC. FLOAT THE SHIELD DRAIN WIRE AT THE DOWNSTREAM END.
2. COMMUNICATIONS CABLE IS BELDEN #9503 OR EQUIVALENT.

## Message Addressing

Each compressor is required to have a unique address referred to as the unit number. The unit number is initially set using dip switch SW1 on the main microprocessor board. However, the actual unit number can be changed through software by setting the Modbus unit number on the appropriate set-up screen on the controller. The following table shows the dip switch settings for up to 31 individual RECIP compressors.

UNIT NUM	DIP SWITCH								UNIT NUM	DIP SWITCH							
	8	7	6	5	4	3	2	1		8	7	6	5	4	3	2	1
1	OFF	OFF	OFF	OFF	OFF	OFF	OFF	ON	17	OFF	OFF	OFF	ON	OFF	OFF	OFF	ON
2	OFF	OFF	OFF	OFF	OFF	OFF	ON	OFF	18	OFF	OFF	OFF	ON	OFF	OFF	ON	OFF
3	OFF	OFF	OFF	OFF	OFF	OFF	ON	ON	19	OFF	OFF	OFF	ON	OFF	OFF	ON	ON
4	OFF	OFF	OFF	OFF	OFF	ON	OFF	OFF	20	OFF	OFF	OFF	ON	OFF	ON	OFF	OFF
5	OFF	OFF	OFF	OFF	OFF	ON	OFF	ON	21	OFF	OFF	OFF	ON	OFF	ON	OFF	ON
6	OFF	OFF	OFF	OFF	OFF	ON	ON	OFF	22	OFF	OFF	OFF	ON	OFF	ON	ON	OFF
7	OFF	OFF	OFF	OFF	OFF	ON	ON	ON	23	OFF	OFF	OFF	ON	OFF	ON	ON	ON
8	OFF	OFF	OFF	OFF	ON	OFF	OFF	OFF	24	OFF	OFF	OFF	ON	ON	OFF	OFF	OFF
9	OFF	OFF	OFF	OFF	ON	OFF	OFF	ON	25	OFF	OFF	OFF	ON	ON	OFF	OFF	ON
10	OFF	OFF	OFF	OFF	ON	OFF	ON	OFF	26	OFF	OFF	OFF	ON	ON	OFF	ON	OFF
11	OFF	OFF	OFF	OFF	ON	OFF	ON	ON	27	OFF	OFF	OFF	ON	ON	OFF	ON	ON
12	OFF	OFF	OFF	OFF	ON	ON	OFF	OFF	28	OFF	OFF	OFF	ON	ON	ON	OFF	OFF
13	OFF	OFF	OFF	OFF	ON	ON	OFF	ON	29	OFF	OFF	OFF	ON	ON	ON	OFF	ON
14	OFF	OFF	OFF	OFF	ON	ON	ON	OFF	30	OFF	OFF	OFF	ON	ON	ON	ON	OFF
15	OFF	OFF	OFF	OFF	ON	ON	ON	ON	31	OFF	OFF	OFF	ON	ON	ON	ON	ON
16	OFF	OFF	OFF	ON	OFF	OFF	OFF	OFF									



## **Software Interface Description**

### **Protocol Overview**

All communications with the Vilter Reciprocating Compressor Controller is on a request-response basis. The main computer is the “master” and the Viltech controller is the “slave”. All messages will originate on the master with the slave responding as required.

### **Status Only or Status and Control Options**

The reciprocating compressor microprocessor communications supports two options. When configured for the Status Only option, the Viltech will only respond to the status message but will not respond to any control or setpoint messages. When configured for the Status and Control option, the Viltech will respond to all message types. The Status and Control option is selected by enabling Modbus communications on the Communications Setup screen. To allow setpoints to be changed, select Yes for the “Allow Network Control” selection. If network control is not allowed, Status Only is selected and an error response will be returned whenever a control message is attempted. When network control is allowed, Status and Control is selected and control messages may be used to control the compressor. The Remote mode is the primary means of control when the Network Control Option is enabled. Remote mode is enabled on the Control Configuration screen.

### **Message Categories**

Several message categories are supported and described below:

- Status Message
- Compressor Control Message
- Suction Pressure Setpoint Message
- Process Temperature Setpoint Message (Optional)

## MODBUS Protocol Description

All transactions will be performed using the Modbus RTU transmission mode. All messages will be terminated with a two-byte CRC-16. The Modbus ASCII transmission mode is not supported.

The default software configuration for Modbus is shown below. Where a parameter can be changed, a range of options is also shown. It is the responsibility of the user to ensure that the software configuration is the same for both the master and slave controllers.

- Baud rate: 9600 bps (2400/4800/9600/19200/38400/76800)
- Data bits: 8 (7/8)
- Parity: None (None/Odd/Even)
- Stop bits: 2 (1/2)

Currently there are only three Modbus message types supported by the Vilter protocol:

- Function Code 03 (0x03): Read Holding Registers
- Function code 06 (0x06): Preset Single Register
- Function Code 16 (0x10): Preset Multiple Registers

Other Modbus message types may become available later or if the need arises. A brief description of the format for each function code will be provided below. However, for a more thorough explanation, please refer to the *Modicon Modbus Protocol Reference Guide (PI-MBUS-300)*

### Read Holding Registers

The Read Holding Registers function code (0x03) is used to read the contents of one or more registers within the Vilter controller. Registers within the Status Message, Control Message and Setpoint Messages may be requested singularly or in groups as long as the number of registers requested does not extend beyond the valid range.

The following table is an example of the use of the Read Holding Registers function code to request all 40 words in the Status Message.

Unit Address	0X??
Function Code	0x03
Starting Address Hi	0x00
Starting Address Lo	0x00
No. of Points Hi	0x00
No. of Points Lo	0x28
CRC-16	0x??

### **Preset Single Register**

The Preset Single Register function code (0x06) is used to change the contents of a single register within the Viltech controller. Any register within the Control Message and Setpoint Messages may be changed as long as the address and data are within the valid range.

The following table is an example of the use of the Preset Single Register function code for changing the value of the S1 Suction Pressure Control Setpoint to 0 PSIG (14.7 PSIA) using Modbus word address 40202.

Unit Address	0X??
Function Code	0x06
Register Address Hi	0x00
Register Address Lo	0xC9
Preset Data Hi	0x00
Preset Data Lo	0x93
CRC-16	0x??

### **Preset Multiple Registers**

The Preset Multiple Registers function code (0x10) is used to change the contents of one or more registers within the Viltech controller. Any group of registers within the Control Message and Setpoint Messages may be changed as long as the number of registers addressed does not extend beyond the valid range.

The following table is an example of the use of the Preset Multiple Registers function code for changing the value of the S1 Suction Pressure Control Setpoint to 0 PSIG (14.7 PSIA) using Modbus word address 40202 (Viltech word address 201).

Unit Address	0X??
Function Code	0x10
Starting Address Hi	0x00
Starting Address Lo	0xC9
No. of Registers Hi	0x00
No. of Registers Lo	0x01
Byte Count	0x02
Data 1 Hi	0x00
Data 1 Lo	0x93
CRC-16	0x??

## Error Messages

The Modbus protocol provides for the return of error codes in the event of a data error within a correctly formatted message block. When the Viltech controller detects an error within a read or write message, the message response will contain an error code instead of the expected data response.

The following example shows an error response to an illegal data value in a Preset Multiple Registers command.

*NOTE: 0x80 has been added to the function code.*

Unit Address	0x??
Function Code	0x90
Error Code	0x03
CRC	0x??

The following error codes are supported:

HEX CODE	ERROR CODE DEFINITION
01	Illegal Function. The function code in the message is not supported.
02	Illegal Data Address. The data address in the message is invalid.
03	Illegal Data Value. At least one data element in a Preset Multiple Registers command was invalid.
07	Negative Acknowledge. The command or data sequence is currently not allowed. This response is usually caused by the failure of the master to set the Network In Control register prior to writing other commands or setpoints. It may also be caused by commands not currently allowed by the mode or state of the compressor.

## Data Formats

For Modbus communications, 16-bit messages are transmitted with the lower 8-bits first followed by the upper 8-bits.

Real number data is represented in 16-bit signed integer format with one or less implied decimal points. For example, the number 127.3 would be stored as 1273 decimal or 04F9 hex. Negative numbers are stored in two's complement form. For example, -237.4 would be stored as -2374 decimal or F6BA hex.

The Discrete I/O parameters are transmitted in a packed binary format where each bit represents an individual input or output. Data marked as optional only applies to RECIP compressors with optional equipment installed.

The Alarm data includes all alarm, failure, and OEM failure conditions currently active on the compressor. The data is transmitted in a packed binary format where each bit represents an individual alarm. Each alarm is assigned one of the following three levels:

- Alarm - The parameter is outside of the normal operating range.
- Fail - Similar to alarm but may cause RECIP to shutdown.
- OEM - A failure caused by parameters exceeding the manufacturer's safety limits.

The Equipment data contains important information about the equipment on the microcontroller. This information is packed into a data block which mixes several types and formats of data.

## Status Message Description

The status message is a read-only message containing analog, discrete, alarm and state data.

*NOTE: Some data in the status message may not apply to your particular compressor, depending on optional equipment and features.*

The Status Message includes the following types of data:

- 16-bit analog input parameters from sensors
- 16-bit derived or computed parameters
- Discrete input and output data in packed bit format
- Alarm data in packed bit format
- Compressor mode and state data

### Analog Inputs and Computed Parameters

Modbus Word Address	Hex Byte Offset	Parameter Name	Range	Units
40001	0000	Suction Pressure	0 : 200	PSIA
40002	0002	Discharge Pressure	0 : 414.5	PSIA
40003	0004	Manifold Pressure	0 : 200	PSIA
40004	0006	Discharge Temperature	32 : 392	DEGF
40005	0008	Oil Temperature	32 : 392	DEGF
40006	000A	Suction Temperature	-58 : 122	DEGF
40007	000C	Pressure Sensor 2	0 : 414.5	PSIA
40008	000E	Process Temp	-58 : 122	DEGF
40009	0010	Spare		
40010	0012	Spare		
40011	0014	Oil Pressure (Computed)	0 : 200	PSID
40012	0016	Staging Capacity	0 : 100	PCT
40013	0018	Motor Speed (Optional)	0 : 100	PCT
40014	001A	Capacity (Computed)	0 : 100	PCT
40015	001C	Display Setpoint	0: 200 (SP) -58:122(PT)	See Word Adrs 31
40016	001E	Anti Cycle Timer	0 : 20	SEC
40017	0020	Enclosure Temperature	-67 : 257	DEGF
40018	0022	Spare		
40019	0024	Spare		



## Discrete Input and Outputs

Modbus Word Address	Hex Byte Offset	Bit	Parameter Name	Input/Output	Active State	
40020	0026	0	COMPRESSOR MOTOR	OUT	HIGH	
		1	CAPACITY STAGE 1	OUT	HIGH	
		2	CAPACITY STAGE 2	OUT	HIGH	
		3	CAPACITY STAGE 3	OUT	HIGH	
		4	CAPACITY STAGE 4	OUT	HIGH	
		5	CAPACITY STAGE 5	OUT	HIGH	
		6	CAPACITY STAGE 6	OUT	HIGH	
			7	ALARM/FAILURE	OUT	LOW
		0027	8	MOTOR AUX	INPUT	HIGH
			9	AUX SHUTDOWN	INPUT	LOW
			A	SAFETY CIRCUIT	INPUT	LOW
			B	REMOTE START/STOP	INPUT	HIGH
			C	CRANK CASE HEATER	OUT	HIGH
			D	OIL RETURN SOLENOID	OUT	HIGH
			E	COOLING CONTROL	OUT	HIGH
			F	SPARE		
40021	0028		0	FRONT PANEL FAIL LED	OUT	HIGH
		1	FRONT PANEL ALARM LED	OUT	HIGH	
		2	FRONT PANEL RUNNING LED	OUT	HIGH	
		3	FRONT PANEL COMM LED	OUT	HIGH	
		4	SPARE			
		5	SPARE			
		6	SPARE			
		7	SPARE			
		0029	8	SPARE		
			9	SPARE		
			A	SPARE		
			B	SPARE		
			C	SPARE		
			D	SPARE		
			E	LCD COLUMN SELECT (INTERNAL)		
			F	LCD FONT SELECT (INTERNAL)		

## Alarm and Failure Data

Modbus Word Address	Hex Byte Offset	Bit	Parameter Name	Level
40022	002A	0	HIGH SUCTION PRESSURE	FAIL
		1	HIGH SUCTION PRESSURE	ALARM
		2	LOW SUCTION PRESSURE	ALARM
		3	LOW SUCTION PRESSURE	FAIL
		4	LOW SUCTION PRESSURE	OEM
		5	HIGH DISCHARGE PRESSURE	OEM
		6	HIGH DISCHARGE PRESSURE	FAIL
	002B	7	HIGH DISCHARGE PRESSURE	ALARM
		8	HIGH DISCHARGE TEMPERATURE	OEM
		9	HIGH DISCHARGE TEMPERATURE	FAIL
		A	HIGH DISCHARGE TEMPERATURE	ALARM
		B	HIGH OIL TEMPERATURE	OEM
		C	HIGH OIL TEMPERATURE	FAIL
		D	HIGH OIL TEMPERATURE	ALARM
		E	LOW OIL TEMPERATURE	ALARM
		F	LOW OIL TEMPERATURE	FAIL
40023	002C	0	LOW OIL TEMPERATURE	OEM
		1	HIGH DISCHARGE PRESSURE 2 (OPTION)	OEM
		2	HIGH DISCHARGE PRESSURE 2 (OPTION)	FAIL
		3	HIGH DISCHARGE PRESSURE 2 (OPTION)	ALARM
		4	LOW OIL PRESSURE	ALARM
		5	LOW OIL PRESSURE	FAIL
		6	LOW OIL PRESSURE	OEM
	002D	7	SPARE	
		8	HIGH PROCESS TEMPERATURE (OPTION)	FAIL
		9	HIGH PROCESS TEMPERATURE (OPTION)	ALARM
		A	LOW PROCESS TEMPERATURE (OPTION)	ALARM
		B	LOW PROCESS TEMPERATURE (OPTION)	FAIL
		C	HIGH INTERMEDIATE PRESSURE (OPTION) SPARE (ONE STAGE)	OEM
		D	HIGH INTERMEDIATE PRESSURE (OPTION)	FAIL
		E	HIGH INTERMEDIATE PRESSURE (OPTION)	ALRM
		F	SEQUENCER SUCTION LOW	ALARM

Alarm and Failure Data (Continued)

Modbus Word Address	Hex Byte Offset	Bit	Parameter Name	Level	
40026	0032	0	AUXILIARY CONTACT	FAIL	
		1	SAFETY CIRCUIT	FAIL	
		2	MASTER SHUTDOWN	FAIL	
		3	ECP COMM SHUTDOWN	FAIL	
		4	SPARE		
		5	SPARE		
		6	SPARE		
		0033	7	MOTOR ON/AUX OPEN	FAIL
			8	MOTOR ON/AUX OPEN	FAIL
			9	MOTOR OFF/AUX CLOSED	FAIL
			A	MOTOR OFF/AUX CLOSED	FAIL
			B	SPARE	
			C	COMM FAIL UNIT 1	FAIL
			D	COMM FAIL UNIT 2	FAIL
			E	COMM FAIL UNIT 3	FAIL
			F	COMM FAIL UNIT 4	FAIL
40027	0034	0	COMM FAIL UNIT 5	FAIL	
		1	COMM FAIL UNIT 6	FAIL	
		2	COMM FAIL UNIT 7	FAIL	
		3	SPARE		
		4	SPARE		
		5	SPARE		
		6	SPARE		
		0035	7	SPARE	
			8	SPARE	
			9	SPARE	
			A	SPARE	
			B	SPARE	
			C	SPARE	
			D	SPARE	
			E	SPARE	
			F	SPARE	

Alarm and Failure Data (Continued)

Modbus Word Address	Hex Byte Offset	Bit	Parameter Name	Level	
40026	0032	0	AUXILIARY CONTACT	FAIL	
		1	SAFETY CIRCUIT	FAIL	
		2	MASTER SHUTDOWN	FAIL	
		3	ECP COMM SHUTDOWN	FAIL	
		4	SPARE		
		5	SPARE		
		6	SPARE		
		0033	7	MOTOR ON/AUX OPEN	FAIL
	8		MOTOR ON/AUX OPEN	FAIL	
	9		MOTOR OFF/AUX CLOSED	FAIL	
	A		MOTOR OFF/AUX CLOSED	FAIL	
	B		SPARE		
	C		COMM FAIL UNIT 1	FAIL	
	D		COMM FAIL UNIT 2	FAIL	
	E		COMM FAIL UNIT 3	FAIL	
	40027	0034	F	COMM FAIL UNIT 4	FAIL
0			COMM FAIL UNIT 5	FAIL	
1			COMM FAIL UNIT 6	FAIL	
2			COMM FAIL UNIT 7	FAIL	
3			SPARE		
4			SPARE		
5			SPARE		
		0035	6	SPARE	
			7	SPARE	
			8	SPARE	
			9	SPARE	
			A	SPARE	
			B	SPARE	
			C	SPARE	
			D	SPARE	
	E	SPARE			
	F	SPARE			

## Equipment Data

Modbus Word Address	Hex Byte Offset	Parameter Name	Format
40028	0036	On-line Indicator	Non Zero = On-line
40029	0038	Alarm Status	See Alarm Table below
40030	003A	Compressor mode	See mode Table below
40031	003C	Compressor State	See State Table below

### Alarm Status Table

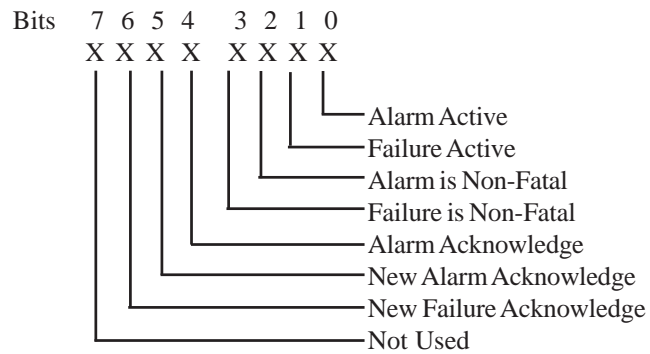

### Compressor Mode Table

Compressor Mode	Value
Automatic	0
Manual	1
Remote	2
Auto-Remote	3
Sequenced	4
Unused	5
Local	6

### Compressor State Table

Compressor State Definition	Value
Anti Cycle	0
Stopped	1
Starting	2
Running	3
Loading	4
Unloading	5
Limited - Motor Current (Not Used)	6
Limited - Capacity	7
Limited - Discharge Pressure	8
Forced unload - Motor Current (Not Used)	9
Forced unload - Discharge Pressure	10
PID State Tuning	11
Stopping	12
Failed	13
Reset	14
Not Used	15
PID State Holding	16
Decreasing	17
Increasing	18
Not Used	19
Stop-Offline	20
Stop-Online	21
Stop-Cutout	22
Run Trim	23
Full Load	24
Blank	25
Comm Fail	26
Spare	27
Limited - Low Suction Pressure	28
Forced Unload - Low Suction Pressure	29
Limited - High Suction Pressure	30
Forced Unload - High Suction Pressure	31

**Last RECIP Start Status Table**

<b>Last Start Status</b>	<b>Value</b>
Start Disabled, Anti-Cycle Timer Running	0
Start Disabled, RECIP Failed	1
Start Disabled, RECIP Already Running	2
Start Disabled, Start Already in Progress	3
RECIP Starting, Auto	4
RECIP Starting, Man	5
RECIP Online, Auto-Remote	6
RECIP Online, Remote	7
RECIP Online, Sequenced	8
RECIP Starting, Local	9
Start Disabled, RECIP in Local mode	10
Start Disabled, RECIP not On-Line	11
Start Disabled, RECIP not in Remote mode	12
RECIP Starting, Remote	13
RECIP Starting, Auto-Remote	14

## Control Message Description

The Control Message is a read/write message containing fields to start and stop the compressor, change the compressor mode, and change the control setpoint group number.

The contents of the Control Message are shown in the following table and described further in the paragraphs below.

*NOTE: The Control Message may not be written unless the Allow Network Control selection is set to Yes. Commands other than Network In Control can only be written once the Network In Control Command has been issued.*

*NOTE: The data described by each register may be slightly different depending on if the register is being read or written.*

Modbus Word Address	Hex Byte Offset	Command Description	Command Format
40101	0000	Network In Control	0 = Ignore cntrl and setpt msgs 1 = Network in control
40102	0002	Compressor Start/Stop	0 = No Change 1 = Stop Compressor 2 = Start Compressor 3 = Shutdown Compressor 4 = Compressor Online
40103	0004	Change Compressor mode	0=Automatic 1=Manual 2=Remote 3=Auto-Remote 4=Sequenced 5=Unused 6=Local
40104	0006	Change Compressor Capacity	0 = Stop Loading Or Unloading. 1 = Load Command. 2 = Unload Command.
40105	0008	Acknowledge/Clear Active Alarms	Non-zero = acknowledge/clear
40106	000A	Change Current Setpoint Group	0-3 = Setpoint Group Number
40107	000C	Change Control Type	0 = Suction Pressure Control 1 = Process Temperature Control
40108	000E	Spare	
40109	0010	Auto Start/Stop Control	0 = Auto Start/Stop disabled 1 = Auto Start/Stop enabled
40110	0012	Spare	



## Network In Control Command

The Network In Control command is used to allow the network to enable or disable itself from controlling the system. When set to zero, the contents of the remainder of the Control Message, the Suction Pressure Setpoint Message, and the Process Temperature Set-point Message will be ignored. When read, the current value of the Network In Control register will be returned.

## Compressor Start/Stop Command

The Compressor Start/Stop command is used to start and stop the compressor or to put the compressor Online, depending on the current mode. When set to 0, nothing will occur. When set to 1, the compressor will stop (if running) but remain Online. A value of 2 will start the compressor as long as the mode is Remote or Auto-Remote and the compressor is Online. A value of 3 will stop the compressor with a failure indication and take it Offline. This command is intended to be used by the master for system safeties (High Level Shutdown, NH3 detection, etc.). A value of 4 will put the compressor Online. The Start and Online commands are also used in conjunction with the Auto Start/Stop Control to allow the compressor to Cut-In and Cut-Out by itself.

***NOTE:** After a failure or if an operator at the local panel hits the **Stop** pushbutton, the compressor must be placed back online by the operator at the machine or through the Online command. It is the responsibility of the system programmer to ensure that restarts after failures are only allowed after the operator verifies the safety and integrity of the system. Also, the Online command may result in the compressor starting immediately, depending on the value of the control parameter.*

The following table summarizes the actions taken for each mode.

Mode	Stop (CMD=1)	Start (CMD=2)	Shutdown (CMD=3)	Online (CMD=4)
Automatic	No action	No action	Stop/fail. Compressor goes Offline	No action
Manual	No action	No action	Stop/fail	No action
Remote	Stops comp. If running, comp. Stays Online	Starts compressor if Online. No action if comp. is Offline.	Stop/fail. Compressor goes Offline	Puts comp. Online allowing start command to work.
Auto-Remote	Stops compressor if running allows compressor to remain Online	Starts comp. if Online. No action if comp. is Offline or Auto Start/ Stop Control is enabled.	Stop/fail. Compressor goes Offline	Puts compressor Online allowing start command to function.
Sequenced	No action	No action	Stop/fail. Comp. goes Offline.	No action
Local	No action	No action	Stop/fail.	No action

## Set Compressor Mode Command

The Set Compressor mode command is used to change the current active mode of the compressor. Normally, only the Remote mode is used by the master. The SEQ, Sequence, mode is then automatically controlled by setpoints and loaded and unloaded automatically. Auto-Remote mode allows the master to provide the control setpoint and the compressor will load and unload to maintain the current active setpoint.

## Change Compressor Capacity Command

The Change Compressor Capacity command allows the master to force the compressor to load or unload. This command word is only processed when the compressor is in the Remote mode. When set to 1 or 2, the compressor will load or unload respectively. Each time the command is written, a single stage will be added or removed.

When read, the current value of the compressor capacity register will be returned (1 if the compressor is loading, 2 if the compressor is unloading, and 0 if the compressor is neither loading or unloading).

## **Acknowledge/Clear Active Alarm Command**

The Acknowledge/Clear Active Alarm command is used by the master computer to silence the audible alarm horn and to clear alarms from the active alarm display. After each new alarm or failure, the first control message received with this word set will only silence the audible alarm horn. Subsequent alarm messages will clear any alarms which are no longer active. This command is ignored when the compressor is in Local mode.

## **Change Current Setpoint Group Command**

The Change Current Setpoint Group command is used to change the current active set-point of the system (Groups 1-4).

When read, the currently selected setpoint group will be returned (0-3 for Suction Pressure Groups, 4-7 for Process Temperature Groups, and 8 for Sequenced)

***NOTE:** This may or may not actually affect the system capacity, depending on the current mode of the compressor. For example, automatic capacity control is not performed in the Manual Mode. Auto Start/Stop Control Command*

## **Change Control Type Command**

The Change Control Type Command is used to switch automatic control between Suction Pressure and Process Temperature operation.

***NOTE:** The Process Temperature Control option must be enabled on the compressor before this command may be issued.*

When read, the current value of the control command will be returned.

## **Auto Start/Stop Control Command**

The Auto Start/Stop Control command is used in the Automatic or Remote modes to allow the compressor to start when the Cut-In setpoint is exceeded and to stop when the Cut-Out setpoint is exceeded. When disabled, the compressor will run until commanded to stop or a failure occurs.

When read, the current value of the Auto Start/Stop register will be returned.

## Suction Pressure Setpoint Message Description

The Suction Pressure Setpoint message is a read/write message used to display or change the four Suction Pressure control group setpoints. Suction Pressure setpoints may be read or written individually or in groups. The master is responsible for setting the correct starting address, number of registers, and the register data for the message block.

**NOTE:** Setpoints may not be changed unless the Allow Network Control selection is set to Yes, and the Network In Control Command has been issued in the Control Message.

DF1 Word Address	Modbus Word Address	Hex Byte Offset	Description	Range	Units
N12:0	40201	0000	S1 Suction Press Cut-In Setpoint	0 : 200	PSIA
1	40202	0002	S1 Suction Press Control Setpoint	0 : 200	PSIA
2	40203	0004	S1 Suction Press Cut-Out Setpoint	0 : 200	PSIA
3	40204	0006	S1 Suction Press Low Alarm	0 : 200	PSIA
4	40205	0008	S1 Suction Press Low Fail	0 : 200	PSIA
5	40206	000A	S2 Suction Press Cut-In Setpoint	0 : 200	PSIA
6	40207	000C	S2 Suction Press Control Setpoint	0 : 200	PSIA
7	40208	000E	S2 Suction Press Cut-Out Setpoint	0 : 200	PSIA
8	40209	0010	S2 Suction Press Low Alarm	0 : 200	PSIA
9	40210	0012	S2 Suction Press Low Fail	0 : 200	PSIA
10	40211	0014	S3 Suction Press Cut-In Setpoint	0 : 200	PSIA
11	40212	0016	S3 Suction Press Control Setpoint	0 : 200	PSIA
12	40213	0018	S3 Suction Press Cut-Out Setpoint	0 : 200	PSIA
13	40214	001A	S3 Suction Press Low Alarm	0 : 200	PSIA
14	40215	001C	S3 Suction Press Low Fail	0 : 200	PSIA
15	40216	001E	S4 Suction Press Cut-In Setpoint	0 : 200	PSIA
16	40217	0020	S4 Suction Press Control Setpoint	0 : 200	PSIA
17	40218	0022	S4 Suction Press Cut-Out Setpoint	0 : 200	PSIA
18	40219	0024	S4 Suction Press Low Alarm	0 : 200	PSIA
19	40220	0026	S4 Suction Press Low Fail	0 : 200	PSIA

Note: DF1 is NOT used.

## Process Temperature Setpoint Message Description

The Process Temperature Setpoint message is a read/write message used to display or change the four Process Temperature control group setpoints. This command is only used if the Process Temperature control option is enabled. Process Temperature setpoints may be read or written individually or in groups. The master is responsible for setting the correct starting address, number of registers, and the register data for the message block.

*NOTE: Setpoints may not be changed unless the Allow Network Control selection is set to Yes, and the Network In Control Command has been issued in the Control Message.*

DF1 Word Address	Modbus Word Address	Hex Byte Offset	Description	Range	Units
N13:0	40301	0000	P1 Process Temp Cut-In Setpoint	-58 : 122	DEGF
1	40302	0002	P1 Process Temp Control Setpoint	-58 : 122	DEGF
2	40303	0004	P1 Process Temp Cut-Out Setpoint	-58 : 122	DEGF
3	40304	0006	P1 Process Temp Low Alarm	-58 : 122	DEGF
4	40305	0008	P1 Process Temp Low Fail	-58 : 122	DEGF
5	40306	000A	P2 Process Temp Cut-In Setpoint	-58 : 122	DEGF
6	40307	000C	P2 Process Temp Control Setpoint	-58 : 122	DEGF
7	40308	000E	P2 Process Temp Cut-Out Setpoint	-58 : 122	DEGF
8	40309	0010	P2 Process Temp Low Alarm	-58 : 122	DEGF
9	40310	0012	P2 Process Temp Low Fail	-58 : 122	DEGF
10	40311	0014	P3 Process Temp Cut-In Setpoint	-58 : 122	DEGF
11	40312	0016	P3 Process Temp Control Setpoint	-58 : 122	DEGF
12	40313	0018	P3 Process Temp Cut-Out Setpoint	-58 : 122	DEGF
13	40314	001A	P3 Process Temp Low Alarm	-58 : 122	DEGF
14	40315	001C	P3 Process Temp Low Fail	-58 : 122	DEGF
15	40316	001E	P4 Process Temp Cut-In Setpoint	-58 : 122	DEGF
16	40317	0020	P4 Process Temp Control Setpoint	-58 : 122	DEGF
17	40318	0022	P4 Process Temp Cut-Out Setpoint	-58 : 122	DEGF
18	40319	0024	P4 Process Temp Low Alarm	-58 : 122	DEGF
19	40320	0026	P4 Process Temp Low Fail	-58 : 122	DEGF

*Note: DF1 is NOT used.*

## *Appendix D - Condensor Control*

*(Important Note)*

### Main Screen



The main screen has been designed to give the operator an overall view of the operating parameters. This screen should always be displayed when setpoint and manual operation items are not being performed and contains buttons to navigate to Auto Setpoints and Manual Operations.

This screen displays status information on the mode of the condenser controller and the stage of the condenser.

### Modes Of Operation

The Condenser Controller always starts in the OFF position. The Controller has two modes of operation. The mode is changed by selecting the preferred mode on the main screen. The modes of operation are as follows:

- 1. Automatic** - Starting and Stopping will be performed automatically based on Discharge Pressure.
- 2. Manual** – In manual mode the user has two options. To increment the stage one by one or to enter the Manual over ride screen.

## Automatic Mode

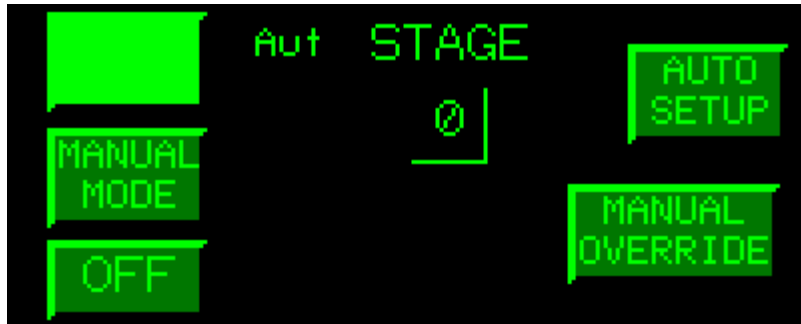

To enter Automatic Mode touch the AUTO MODE button. The button will light up and the words Aut will appear on the screen.

In Automatic mode the Stage operation will be selected automatically based on the designated Discharge Pressure. To set these points see “Auto Setup Screen” section of this manual.

## Automatic Operation

In automatic mode the Condenser Controller will attempt to keep the Discharge Pressure within the deadband range. Once the discharge pressure moves outside the specified dead band range the Controller will wait the specified amount of seconds and toggle the appropriate stage.

The Main Screen will state the appropriate stage. The picture below shows the Controller in the second stage.



## Auto Setup Screen

From the Main screen, touch the AUTO SETUP button.

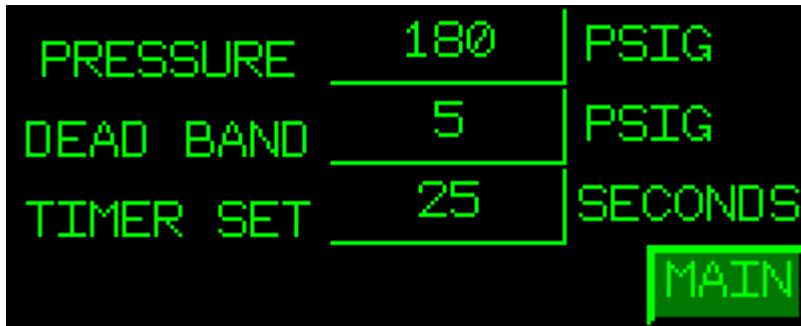

To specify the setpoints for Pressure, Dead Band, or Timer touch the number inside the green rectangle to bring up a keypad, as shown below.

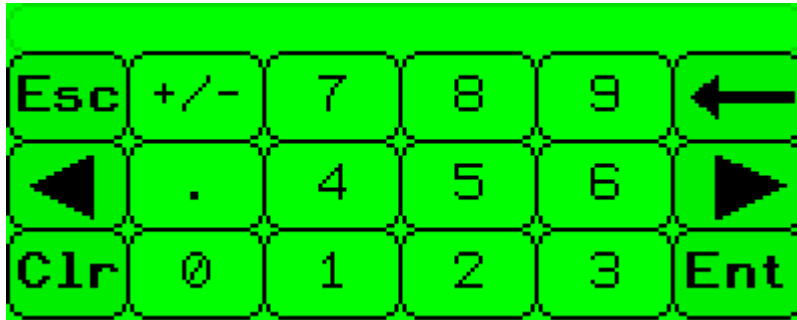

In this screen you can specify the appropriate value for the given parameter. When finished touch the Ent button to return to the Auto Setup Screen.

Pressure value can not exceed three digits and should always stay within safe operating conditions specified by the condenser manufacture.

Deadband value can not exceed three digits and should always stay within safe operating conditions specified by the condenser manufacture.

Timer Set value can not exceed two digits and should stay within safe operating conditions specified by the condenser manufacture

To return to the Main Screen touch the MAIN button.



## Manual Mode

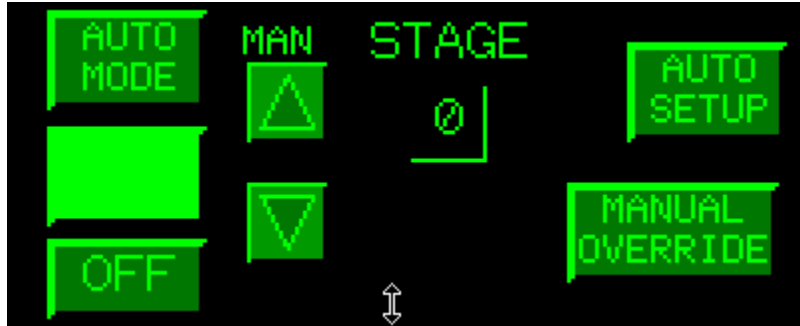

To enter Manual Mode touch the MANUAL MODE button. The button will light up and the words MAN will appear on the screen. Also the up and down toggle arrows will appear.

From the main screen you can move up and down through the stages by pressing the up or down toggle arrows.

## Manual Override Screen

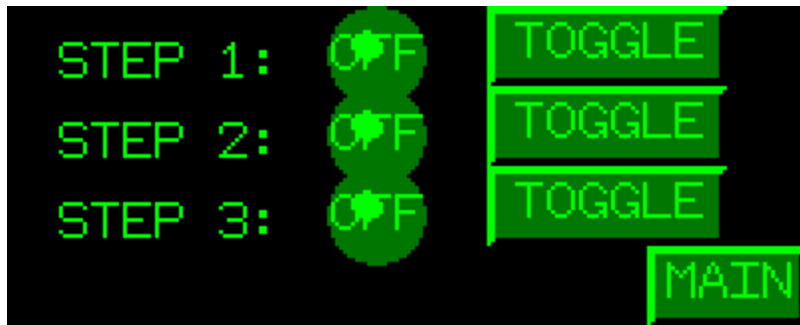

To enter the Manual Override Screen touch the MANUAL OVERRIDE button.

In the Manual Override Screen you can operate each stage individually. To operate a given stage touch the corresponding toggle button. When the specified stage is selected the light will become illuminated as well as the toggle button itself and shut off a specified stage touch the corresponding toggle button. When the specified stage is no longer running the light next to said stage will read “OFF” and the light and toggle button will no longer be illuminated.

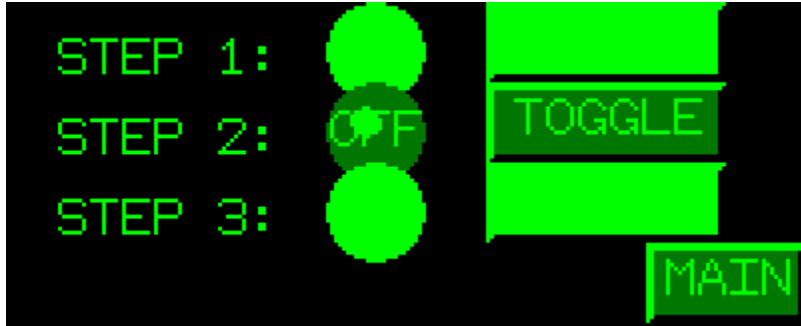

Stages 1 and 3 are on as shown above.

**IMPORTANT NOTE:** THE OPERATOR SHOULD SHUT OFF ALL STAGES BEFORE EXITING MANUAL OVERRIDE SCREEN.

Exiting the Manual Override screen will not change the status of the steps selected. Entering into Auto Mode or Off Mode from the Main Screen will shut off the stages until you enter Manual Mode again. When the operator enters back into Manual Mode the stages selected in the Manual Override screen will begin to run again.

### **Communication Failure**

If the HMI loses communications with the Processor a “COM Port Open Failed” message will appear on the screen, as shown below.

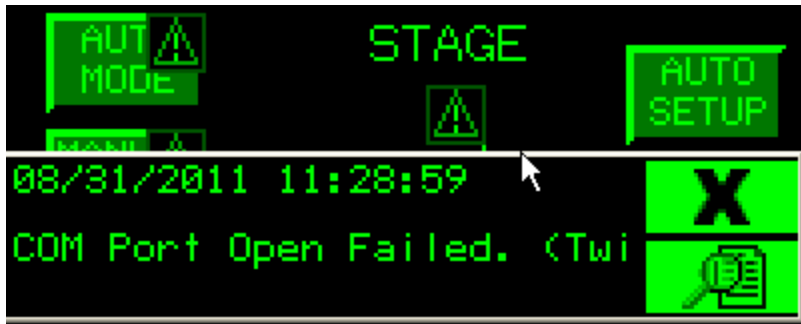

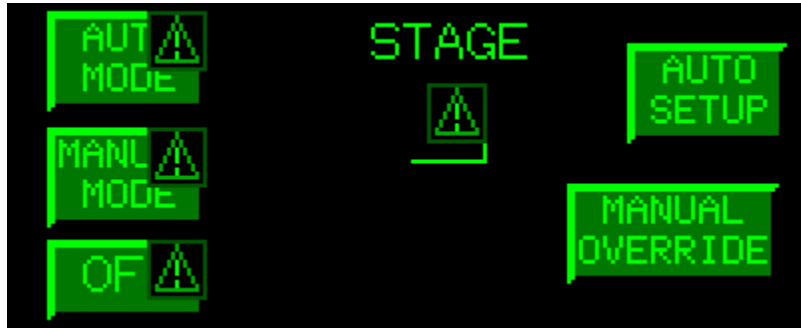

Condenser operation will no longer be controlled by the HMI. The operator will have to control the stages at the motor starter by using either HAND or OFF.





EmersonClimate.com

## Free Manuals Download Website

<http://myh66.com>

<http://usermanuals.us>

<http://www.somanuals.com>

<http://www.4manuals.cc>

<http://www.manual-lib.com>

<http://www.404manual.com>

<http://www.luxmanual.com>

<http://aubethermostatmanual.com>

Golf course search by state

<http://golfingnear.com>

Email search by domain

<http://emailbydomain.com>

Auto manuals search

<http://auto.somanuals.com>

TV manuals search

<http://tv.somanuals.com>