

AL-M8250DN AL-M8150DN
Epson Print Admin Serverless

Setup & Administration Guide

Contents

Introduction

The Content of This Document.	4
Using this Guide.	4
Marks and Symbols.	4
Screenshots Used in This Guide.	4
Operating System References.	4
Terms.	5

Overview for the Authentication

Method

Device Authentication (Local DB).	7
LDAP Server Authentication.	7
Device Authentication and LDAP Server Authentication (Local DB and LDAP).	7

System Requirements

Printer.	8
Client Computer.	9

Setting Overview

Using Software for Setting.	10
Web Config.	10
Epson Device Admin.	11
Required Settings for the Authentication Method.	12
Flow to Set Up Printers Individually.	12
Flow to Set Up Printers in Bulk.	14
Application Configuration Comparison.	15

Authentication Device Connection

Connecting the authentication device.	18
Operation Check for Authentication device.	20
Available Reading Method for Authentication Information.	20
Authentication Device Setting Items.	20
Authentication Device, Card ID Save Format Setting Items.	21

Information Registration and System Configuration

About License Key Acquisition.	22
Registration for the License Key.	22
Registering the License Key by Using Web Config.	22

Registering the License Key by Using Epson Device Admin.	23
Creating the Configuration Template.	24
Importing the License Key.	25
Applying the Configuration Template.	26
Set the Printer Individually Using Web Config.	28
Using Epson Print Admin Serverless Setting List.	29
Making User Authentication Settings (Web Config).	29
Making Print Job Settings (Web Config).	31
Registration for the User Information (Web Config).	32
Synchronization with the LDAP Server (Web Config).	37
Options Functions Setting (Web Config).	39
Batch Setting Using Epson Device Admin (Configuration Template).	42
Operation Flow of Epson Device Admin.	43
Making User Authentication Settings (Configuration Template).	45
Making Authentication Device Settings (Configuration Template).	45
Making Print Job Settings (Configuration Template).	46
Synchronizing with the LDAP Server (Configuration Template).	47
Registration for the User Information (Configuraiton Template).	51
Other Functions Setting (Configuration Template).	55

Client Computer Setting

Installation for the Printer Driver.	58
Printer Driver Setting.	58
User Settings for Windows Printer Driver.	58
User Settings for Mac OS Printer Driver.	59
Connection Format for Authentication Information.	60

Operation and Management

Setting an Administrator Password and Administrator Lock.	61
User Reports Using Epson Device Admin.	61
Creating User Reports.	61
Report Output Items.	66
Managing Printers by Using Epson Device Admin.	67

Contents

Displaying Epson Print Admin Serverless Settings menu.	67
User Maintenance.	68
Checking the Printer Information from Web Config.	71
Email Notifications and Snapshots.	72
Deleting the Print Jobs.	73
Backing Up the Settings.	74
Settings in Web Config.	74
Configuration Templates in Epson Device Admin.	75
Disabling Epson Print Admin Serverless.	77
Disabling from Web Config.	77

Solving Problems

Cannot Read the Authentication Card.	79
Cannot Open Web Config.	79
Cannot Activate Epson Print Admin Serverless.	79
The Message that Indicates the License Key Has Expired Is Displayed.	79
Epson Device Admin Report Has No Content.	79

Appendix

Functions that Enhance Printer Security.	81
User Information Recorded in the Printer.	81
Trademarks.	82

Introduction

The Content of This Document

This guide explains the procedures from the installation to daily management of Epson Print Admin Serverless. For the standard function of the printer, see the manual for your printer.

Using this Guide

Marks and Symbols

**Caution:**

Instructions that must be followed carefully to avoid bodily injury.

**Important:**

Instructions that must be observed to avoid damage to your equipment.

Note:

Provides complementary and reference information.

Related Information

➔ Links to related sections.

Screenshots Used in This Guide

Setting items may vary depending on products and setting conditions.

Operating System References

Windows

In this manual, terms such as "Windows 10", "Windows 8.1", "Windows 8", "Windows 7", "Windows Vista", "Windows XP", "Windows Server 2019", "Windows Server 2016", "Windows Server 2012 R2", "Windows Server 2012", "Windows Server 2008 R2", "Windows Server 2008", "Windows Server 2003 R2", and "Windows Server 2003" refer to the following operating systems. Additionally, "Windows" is used to refer to all versions.

- Microsoft® Windows® 10 operating system
- Microsoft® Windows® 8.1 operating system
- Microsoft® Windows® 8 operating system

Introduction

- Microsoft® Windows® 7 operating system
- Microsoft® Windows Vista® operating system
- Microsoft® Windows® XP operating system
- Microsoft® Windows® XP Professional x64 Edition operating system
- Microsoft® Windows Server® 2019 operating system
- Microsoft® Windows Server® 2016 operating system
- Microsoft® Windows Server® 2012 R2 operating system
- Microsoft® Windows Server® 2012 operating system
- Microsoft® Windows Server® 2008 R2 operating system
- Microsoft® Windows Server® 2008 operating system
- Microsoft® Windows Server® 2003 R2 operating system
- Microsoft® Windows Server® 2003 operating system

Mac OS

In this manual, "Mac OS" is used to refer to Mac OS X v10.7.0 or later.

Terms

Epson Print Admin Serverless

The system provided by Epson that can authenticate the users who use printers with only the printer itself.

License Key

The key to activate Epson Print Admin Serverless.

User ID

The unique ID of authenticated users for Epson Print Admin Serverless.

ID Number

The 4 to 8 digit number that is associated with the user ID.

User information

The general term for user authentication-related information such as user ID, password, ID number, and email address.

Authentication device

The device to authenticate users by entering information, such as IC card reader.

Administrator

The person in charge of installing and setting the device or the network at an office or organization. For small organizations, this person may be in charge of both device and network administration. For large organizations, administrators have authority over the network or devices on the group unit of a department or division, and

Introduction

network administrators are in charge of the communication settings for beyond the organization, such as the Internet.

LDAP server

The server that provides a directory service that can communicate with LDAP. This includes Windows server Active Directory, Linux OpenLDAP, etc.

Print job

The print data sent to the printer from client computers.

Unicode (UTF-8)

An international standard code, covering the major global languages. When "UTF-8" is described in this guide, it indicates coding characters in UTF-8 format.

ASCII (American Standard Code for Information Interchange)

One of the standard character codes. 128 characters are defined, including such characters as the alphabet (a-z, A-Z), Arabic numbers (0-9), symbols, blank characters, and control characters. When "ASCII" is described in this guide, it indicates the 0x20 - 0x7E (hex number) listed below, and does not involve control characters.

	00	01	02	03	04	05	06	07	08	09	0A	0B	0C	0D	0E	0F
20	SP*	!	"	#	\$	%	&	'	()	*	+	,	-	.	/
30	0	1	2	3	4	5	6	7	8	9	:	;	<	=	>	?
40	@	A	B	C	D	E	F	G	H	I	J	K	L	M	N	O
50	P	Q	R	S	T	U	V	W	X	Y	Z	[\]	^	_
60	`	a	b	c	d	e	f	g	h	i	j	k	l	m	n	o
70	p	q	r	s	t	u	v	w	x	y	z	{		}	~	

* Space character.

Overview for the Authentication Method

When using Epson Print Admin Serverless, the authentication function can be used only with the printer on the network.

Device Authentication (Local DB)

This authentication system checks the user information registered to the printer and the users who use the printing functions. Because user information is associated with the job history, administrators can learn the usage status for each user.

User information can be registered for up to 1,000 users, including users who are entered directly, imported by a CSV file, and imported from the LDAP server.

It is necessary to register the user information to the printer in advance.

LDAP Server Authentication

This is the authentication that checks the user information of the LDAP server synchronized with the printer. Because the user information is temporarily stored to the printer as a cache for up to 1,000 users, it is available to authenticate using the cache even when the LDAP server goes down.

It is necessary to set up the LDAP server in advance.

Device Authentication and LDAP Server Authentication (Local DB and LDAP)

This is the authentication that checks the user information registered both in the printer and in the LDAP server synchronized with the printer. When checking for user information, the first search is performed on user information registered to the printer, and then it searches the LDAP server if the relevant information is not found. User information can be registered for up to 1,000 users. The vacant portion is used as a cache for the LDAP server, and the user information of the LDAP server is registered to the printer temporarily. If the LDAP server goes down, this cache can be used to authenticate users.

It is necessary to register the user information to the printer and set up the LDAP server in advance.

System Requirements

Printer

HDD (Optional)

To use Epson Print Admin Serverless, you need to install an optional hard disk.

See the *User's Guide* for details on how to install the optional hard disk.

Firmware

AL-M8250DN

Firmware version : RA19LB (November 19, 2021) or later

AL-M8150DN

Firmware version : RB19LB (November 19, 2021) or later

Web Browser for Web Config

Internet Explorer 9 or later

Microsoft Edge

Google Chrome (latest edition)

Mozilla Firefox (latest edition)

Safari: Ver.6 or later

Client Computer

Operation System

- Windows :
 - Windows 10
 - Windows 8.1
 - Windows 8
 - Windows 7
 - Windows Vista
 - Windows XP
 - Windows XP Professional x64 Edition
 - Windows Server 2019
 - Windows Server 2016
 - Windows Server 2012 R2
 - Windows Server 2012
 - Windows Server 2008 R2
 - Windows Server 2008
 - Windows Server 2003 R2
 - Windows Server 2003
- Mac OS :
 - Mac OS X v10.7.0 or later

Printer Driver

- Windows: Standard driver (version 3.01 or later)
- Mac OS: Standard driver (version 10.93 or later)

Setting Overview

You can choose the setup method depending on the number of printers you install or your network environment.

Using Software for Setting

Explain the software to set up.

Web Config

Web Config is a built-in web page of the printer for configuring the printer's settings. Since it operates by directly accessing the printer through the network, it is suitable for setup one by one.

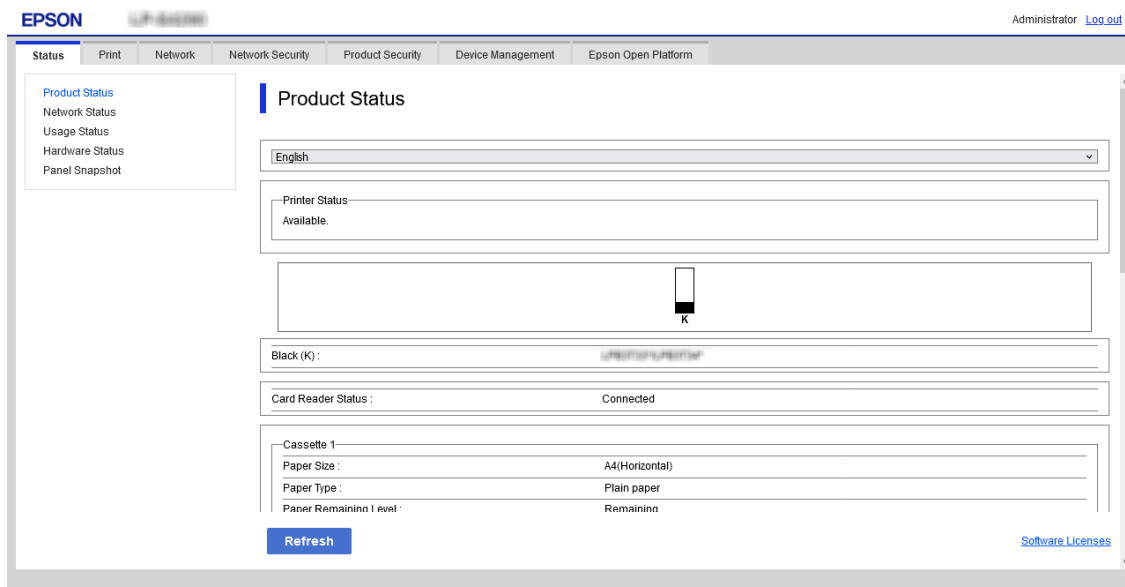

Accessing Web Config

Enter the printer's IP address into a web browser. JavaScript must be enabled. When accessing Web Config via HTTPS, a warning message will appear in the browser since a self-signed certificate, stored in the printer, is used but there is no problem.

- Accessing via HTTPS
 - IPv4: `https://<printer IP address>` (without the < >)
 - IPv6: `https://[printer IP address]/` (with the [])
- Accessing via HTTP
 - IPv4: `http://<printer IP address>` (without the < >)
 - IPv6: `http://[printer IP address]/` (with the [])

Setting Overview

Examples

❑ IPv4:

https://192.0.2.111/
http://192.0.2.111/

❑ IPv6:

https://[2001:db8::1000:1]/
http://[2001:db8::1000:1]/

Note:

If the printer name is registered with the DNS server, you can use the printer name instead of the printer's IP address.

Epson Device Admin

Epson Device Admin is multifunctional application software that manages the device on the network. The following functions are available, so it is useful when you install and manage the multiple printers.

- ❑ Apply the unified settings to multiple printers over the segment .
- ❑ Make a detailed report, such as for the job history or usage history.

You can download Epson Device Admin from Epson support website. For more information, see the documentation or help of Epson Device Admin.

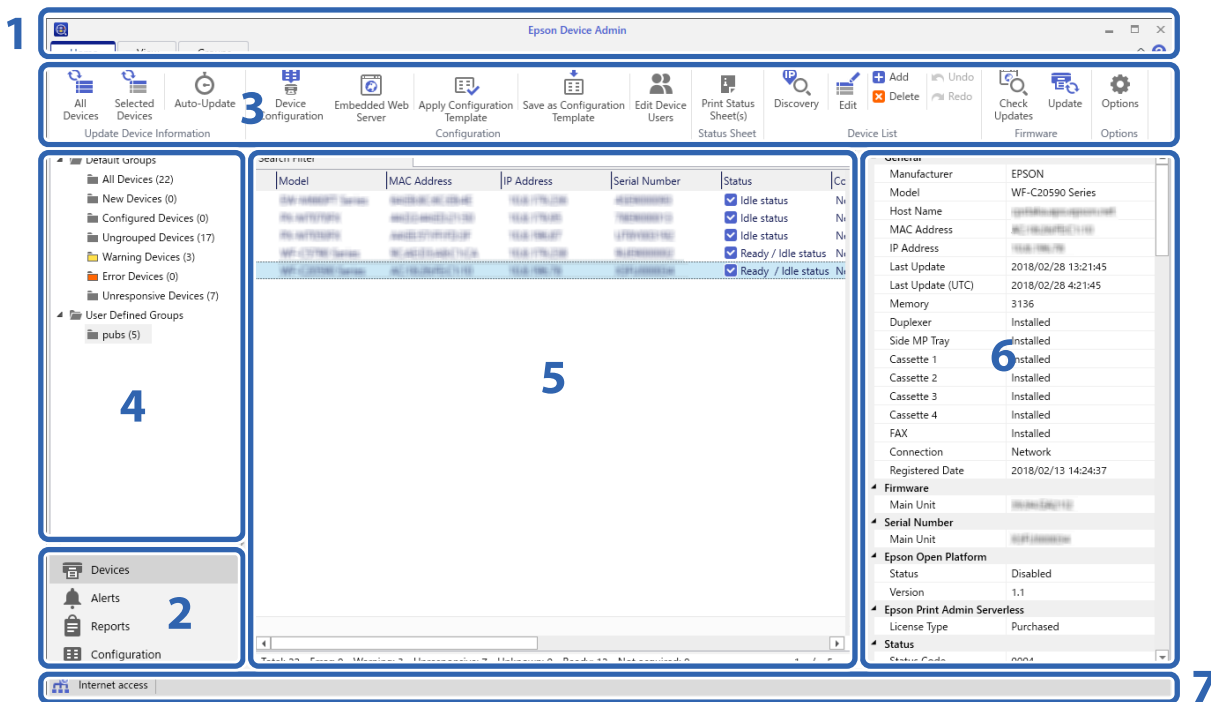

The Epson Device Admin top screen is composed of the following panes.

The display changes depending on the item selected from the side bar task menu on the top screen.

No.	Pane	Explanation
1	Title bar	Click the  to open the Help to view explanations of each item in Epson Device Admin.

Setting Overview

No.	Pane	Explanation
2	Side bar task menu	Changes the feature being used. The screen switches depending on the item selected.
3	Ribbon menu	Displays the menu for the feature selected on the side bar task menu.
4	Side bar content	Displays the hierarchy for the feature selected on the side bar task menu.
5	Display view	Displays information and setting content depending on the feature selected in the side bar task menu or the side bar content.
6	Detailed device information	Displays details on the device selected from the Device List when you select Devices on the side bar task menu.
7	Status bar	Displays status information on the Device List when you select Devices on the side bar task menu.

Required Settings for the Authentication Method

Depending on the authentication method you use, the required settings differ. Set up the printer by referring below.

Settings	Local DB	LDAP	Local DB and LDAP
Registering the license key	✓	✓	✓
Connecting and setting the authentication device	✓*	✓*	✓*
User authentication setting	✓	✓	✓
Print job setting	✓	✓	✓
Access control setting	✓	✓	✓
LDAP server setting	-	✓	✓
Registration for user information	✓	-	✓

* : When **Card or User ID and Password** or **Card or ID Number** is selected as the authentication method.

Flow to Set Up Printers Individually

Explains the procedure to set up Epson Print Admin Serverless on an individual printer. When you use Web Config, you can set up the printer only by using a web browser.

Setting Overview

! **Important:**

Before starting the setup, check that the time setting for the printer is correct.

If the time setting is incorrect, the error message "License is expired" is displayed, which may lead to failure to set up Epson Print Admin Serverless. Also, in order to use a security function such as SSL/ TLS communication or IPsec, the correct time must be set. You can set the time as follows.

- Web Config: **Device Management** tab > **Date and Time** > **Date and Time**.
- Printer's control panel: **Settings** > **General Settings** > **Basic Settings** > **Date/Time Settings**

Procedure		Operations	Details
1	Connecting the authentication device*1	Connecting the authentication device to the printer and checking the operation	Connect the authentication device to the printer.
2	Date/Time setting	Setting the date and time	Set the correct date and time in the printer.
3	Registering the license key*2	Entering the license key	Activate Epson Print Admin Serverless to the printer by using Web Config.
4	Setting Epson Print Admin Serverless	Setting for authenticated printing	Set authentication method and how to authenticate user.
		Setting the print job	Set up for saving or deleting the print job.
		Registering the user information	Register the user information. Set the following depending on the authentication method. <input type="checkbox"/> Set the LDAP server synchronizing setting. <input type="checkbox"/> Import from the files.
		Setting for arbitrary function	Set arbitrary function settings as necessary, such as authentication device settings depending on the authentication method being used and how to authenticate the user you selected.
5	Setting the client computer	Installing the printer driver, setting the user ID to the printer driver	On the printer driver that is installed on the client computer, set the user ID to authenticate the users.

*1 : Set when you use an authentication device to authenticate users.

*2 : It may have been set by the dealer.

Related Information

- ➡ [“Set the Printer Individually Using Web Config” on page 28](#)
- ➡ [“Client Computer Setting” on page 58](#)

Flow to Set Up Printers in Bulk

Explains the procedure to set up Epson Print Admin Serverless on multiple printers. When you use the configuration template for Epson Device Admin, you can set up the printers efficiently.



Important:

Before starting the setup, check that the time setting for the printer is correct.

If the time setting is incorrect, the collected time of the log or report will also be incorrect, so it will be difficult to trace unauthorized use or information leaks. Also, in order to use a security function such as SSL/ TLS communication or IPsec, the correct time must be set. You can set the time as follows.

- Web Config: **Device Management** tab > **Date and Time** > **Date and Time**.
- Printer's control panel: **Settings** > **General Settings** > **Basic Settings** > **Date/Time Settings**

Procedure		Operations	Details
1	Connecting the authentication device* ¹	Connecting the authentication device to the printer and checking the operation	Connect the authentication device to the printer.
2	Date/Time setting	Setting the date and time	Set the correct date and time in the printer.
3	Registering the license key* ²	Creating the configuration template	Activate Epson Print Admin Serverless to the multiple printers by using configuration template.
		Importing the license key	
		Applying the configuration template	
4	Setting Epson Print Admin Serverless	Editing or creating the configuration template	Edit or create the configuration template.
		Setting for authenticated printing	Set authentication method and how to authenticate user.
		Setting the print job	Set up for saving or deleting the print job.
		Setting for arbitrary function	Set arbitrary function settings as necessary, such as authentication device settings depending on the authentication method being used and how to authenticate the user you selected.
		Registering the user information	Register the user information. Set the following depending on the authentication method. <input type="checkbox"/> Set the LDAP server synchronizing setting. <input type="checkbox"/> Import from the files or LDAP server.
		Applying the configuration template	Apply the configuration template to each printer.
5	Setting the client computer	Installing the printer driver, setting the user ID to the printer driver	On the printer driver that is installed on the client computer, set the user ID to authenticate the users.

Setting Overview

*1 : Set when you use an authentication device to authenticate users.

*2 : It may have been set by the dealer.

Related Information

➔ [“Batch Setting Using Epson Device Admin \(Configuration Template\)” on page 42](#)

➔ [“Client Computer Setting” on page 58](#)

Application Configuration Comparison

These are the items that can be set by each application (can be set = ✓, cannot be set = -).

Product Key or License Key

Item	Web Config	Epson Device Admin
Epson Open Platform Version	✓	✓
Product Key or License Key	✓	✓

Authentication Settings

Item	Web Config	Epson Device Admin
Authentication Method	✓	✓
How to Authenticate User	✓	✓
Allow users to register authentication cards	✓	✓
The Minimum Digit Number of ID Number	✓	✓
Caching for LDAP authenticated users	✓	✓

Print Jobs

Item	Web Config	Epson Device Admin
Maximum time limit for unreleased job (0 to 720 hours)	✓	✓
User name in Epson Device Admin log	✓	✓
Direct Print setting for the printer driver	✓	✓
Delete All Print Jobs	✓	-

User Settings

Item	Web Config	Epson Device Admin
User ID	✓	✓

Setting Overview

Item	Web Config	Epson Device Admin
User name Display	✓	✓
Password	✓	✓
Authentication Card ID	✓	✓
ID Number	✓	✓
Department	✓	✓
Functional Restriction	✓	✓

Access Control Settings

Item	Web Config	Epson Device Admin
Enables Access Control	✓	✓
Allow printing and scanning without authentication information from a computer	✓	✓
Allow registered users to log in to Web Config	✓	-

Card Reader

Item	Web Config	Epson Device Admin
Vendor ID	✓	✓
Product ID	✓	✓
Operational parameter	✓	✓
Card Reader	✓	✓
Authentication Card ID save format	✓	✓
Set card ID range	✓	✓
Text Start Position	✓	✓
Number of Characters	✓	✓

LDAP Server > Search Settings

Item	Web Config	Epson Device Admin
Search Base (Distinguished Name)	✓	✓
User ID Attribute	✓	✓
User name Display Attribute	✓	✓
Department Attribute	✓	✓
ID Number Attribute	✓	✓

Setting Overview

Item	Web Config	Epson Device Admin
Authentication Card ID Attribute	✓	✓

Reports

Item	Web Config	Epson Device Admin
Usage Per User	-	✓
Usage Per Department*1	-	✓
Job History	-	✓

*1 : If you print a job without storing it in the printer, a report for Usage Per Department is not created.

Related Information

- ➔ [“Set the Printer Individually Using Web Config” on page 28](#)
- ➔ [“Batch Setting Using Epson Device Admin \(Configuration Template\)” on page 42](#)

Authentication Device Connection

Connect and set up the authentication device to use user authentication. This is not necessary if you do not use an authentication device.

Note:

For an authentication device other than IC card reader, ask your dealer.

Connecting the authentication device

You can connect the authentication device by using a USB cable.



Caution:

- ❑ Use a product with the same model number as the authentication device that was used to confirm the authentication card for the authentication device connected to the printer. If you use a different authentication device, you may not be able to logon.

1. Remove the cover of service port (a).

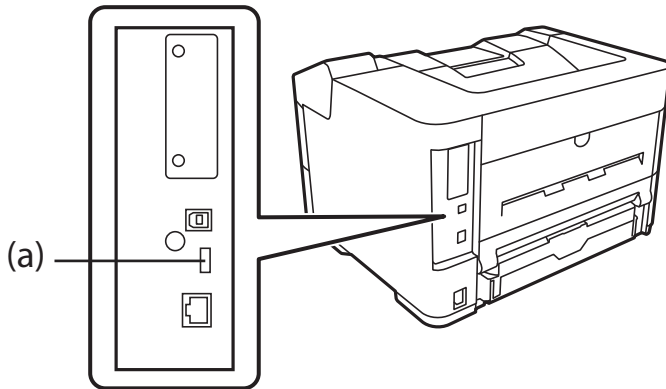

Authentication Device Connection

2. Connect the USB cable for the authentication device to the printer.

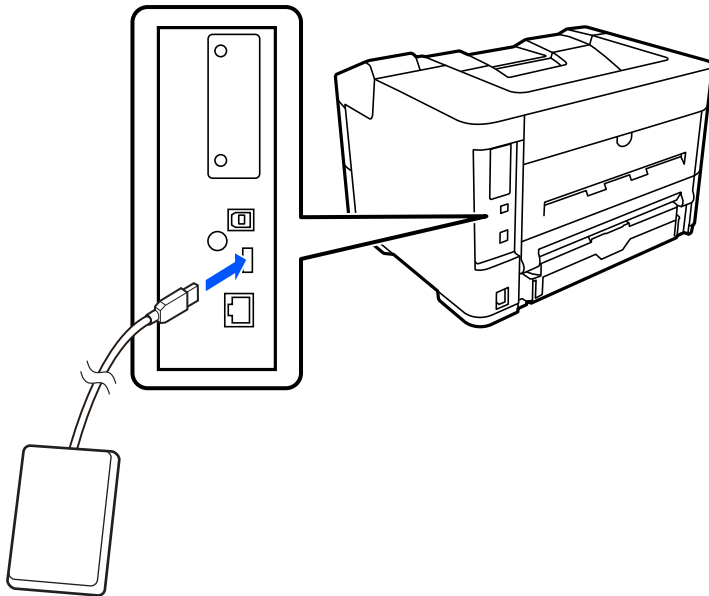

3. When attaching the card reader to the printer, fix it to the upper surface on the right side of the printer with double-sided tape.



Important:

When installing on the main unit, be sure to install it in the position specified in the following figure. Installing it in the wrong position may damage the device due to heat exhausted by the printer or moving parts.

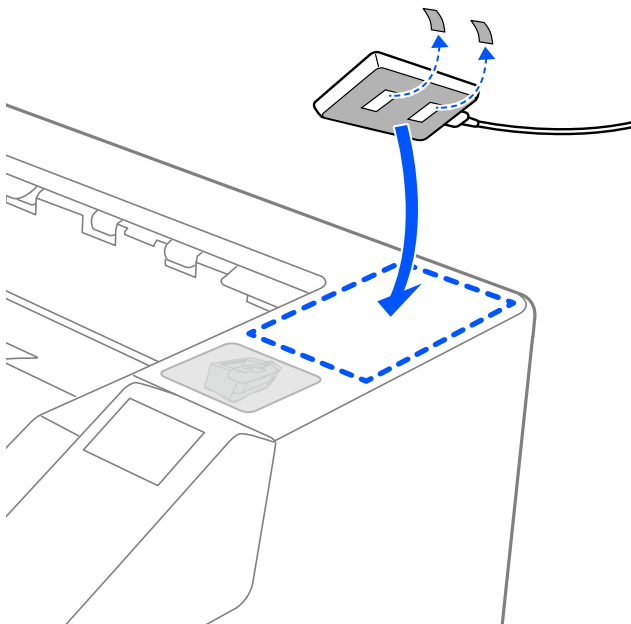

Operation Check for Authentication device

The following procedures explain how to check the connection status and authentication card recognition for the authentication device.

Printer's control panel

Information is displayed if you select **Settings > Authentication Device Status**.

Configuration Status Sheet

Status is displayed in **Hardware Configuration > Hardware > Card Reader Status**.

See the manual provided with the printer how to print a Configuration Status Sheet.

Available Reading Method for Authentication Information

You can set the following reading method for the authentication device.

You can set it to the printer using Web Config or Epson Device Admin.

The settings are required in the following cases.

Read the particular area of the authentication card, such as employee number and personal ID.

Use the authentication card information except for UID (authentication card information such as serial number.)

You can generate the operational parameter by using a tool. Ask your dealer for details.

Note:

Using authentication cards from different manufacturers:

When using UID for card information (card ID information such as the serial number), you can use a mix of different types of authentication cards. This cannot be mixed when using other card information.

Authentication Device Setting Items

Item	Explanation
Vendor ID	Set the vendor ID of the authentication device that limits use from 0000 to FFFF by using 4 alphanumeric characters. If you do not want to limit it, set to 0000.
Product ID	Set the product ID of the authentication device that limits use from 0000 to FFFF by using 4 alphanumeric characters. If you do not want to limit it, set to 0000.
Operational parameter	Set the operation parameter of the authentication device between 0 and 8192 characters. A~Z, a~z, 0~9, +, /, =,space, and line feed are available.

Authentication Device Connection

Item		Explanation
Epson Print Admin Serverless	Card Reader	Select the conversion format for authentication device.
	Authentication Card ID save format	Select the conversion format for authentication information of an ID card.
	Set card ID range	Enable specification of the reading position.
	Text Start Position	Specify the text start position and the number of characters. You can specify between 1 and 4096.
	Number of Characters	Specify the number of characters of reading ID information. You can specify between 1 and 4096.

Authentication Device, Card ID Save Format Setting Items

Format	Description
Format 1 (Default)	Outputs the binary value as a hexadecimal.
Format 2	Outputs the value obtained by rearranging the Upper Lower byte binary value as a hexadecimal number.
Format 3	Outputs the value obtained by rearranging the Upper Lower bit by bit conversion as a hexadecimal number.
Format 4	Outputs a binary value as a decimal number.
Format 5	Outputs the value obtained by rearranging the Upper Lower byte binary value as a decimal number.
Format 6	Outputs the value obtained by rearranging the Upper Lower bit by bit calculated as a decimal number.
Format 7	Outputs the binary value as a hexadecimal ASCII string.
Format 8	Outputs the value obtained by rearranging the Upper Lower byte of the binary value as a hexadecimal ASCII string.
Format 9	Outputs the value obtained by rearranging the Upper Lower bit by bit calculated as a hexadecimal ASCII string.
Format 10	Outputs the binary value as a decimal ASCII string.
Format 11	Outputs the value obtained by rearranging the Upper Lower byte of the binary value as a decimal ASCII string.
Format 12	Outputs the value obtained by rearranging the Upper Lower bit by bit calculated as a decimal ASCII string.
Format 13	Outputs a binary value as an ASCII string.

Related Information

- ➔ [“Making Authentication Device Settings \(Web Config\)” on page 41](#)
- ➔ [“Making Authentication Device Settings \(Configuration Template\)” on page 45](#)

Information Registration and System Configuration

Set the necessary items to install Epson Print Admin Serverless.

When you set the printer individually, use Web Config. When you set multiple printers in bulk, use Epson Device Admin.

Related Information

- ➔ [“Registering the License Key by Using Web Config” on page 22](#)
- ➔ [“Registering the License Key by Using Epson Device Admin” on page 23](#)
- ➔ [“Set the Printer Individually Using Web Config” on page 28](#)
- ➔ [“Batch Setting Using Epson Device Admin \(Configuration Template\)” on page 42](#)

About License Key Acquisition

You need a license key to use Epson Print Admin Serverless.

To find out how to acquire the license key or for more details, ask your dealer.

Registration for the License Key

Activate Epson Print Admin Serverless by registering the license key to the printer.

Note:

The license key may be registered to the printer by dealer. In this case, skip this step and go to the settings for Epson Print Admin Serverless.

Registering the License Key by Using Web Config

Use Web Config when you want to register the license key to the printer individually.

1. Use one of the following methods to connect the printer to the setup computer.
 - Connect by wired or wireless LAN
If you want to connect using a wired connection or wireless LAN, connect to the network in the same segment as the setup computer.
 - Connect directly using a LAN cable
2. Turn on the printer.
3. On a setup computer, open your web browser, and then open the printer's Web Config by entering "https://<epsondevice-IP>".

When the printer's IP address is "192.168.111.10" : https://192.168.111.10

Information Registration and System Configuration

You can check the IP address from the printer's control panel.

See the manual for your printer for details.

Note:

When you access the administrator login page in SSL communication (https), the message "There is a problem with this website's security certificate" may be displayed.

This happens when the browser attempts an SSL encrypted communication when the Web site is using a self-signed certificate. Click "Continue browsing of this site (not recommended)". To avoid displaying this warning, use a certificate issued by a trusted certification authority.

4. Select **Epson Open Platform** tab > **Product Key or License Key**.
5. Enter the license key to **Product Key or License Key**.

6. Click **Next**.
7. Click **OK**.

After a moment, click **Refresh the menu** and reload the page for Web Config.

If the license information is displayed, **Epson Print Admin Serverless** is activated.

Registering the License Key by Using Epson Device Admin

When you use a configuration template for Epson Device Admin, you can apply the license keys given in the CSV file to multiple printers.

Information Registration and System Configuration

1. Create a new configuration template.
2. Read the license key on the configuration template.
3. Apply it to the target printers.

Creating the Configuration Template

Create the configuration template newly.

1. Start Epson Device Admin.
2. Select **Configuration** on the side bar task menu.

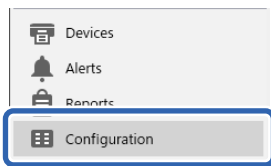

3. Select **New** on the ribbon menu.

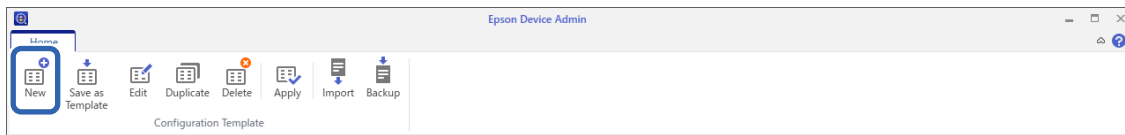

4. Set each item.

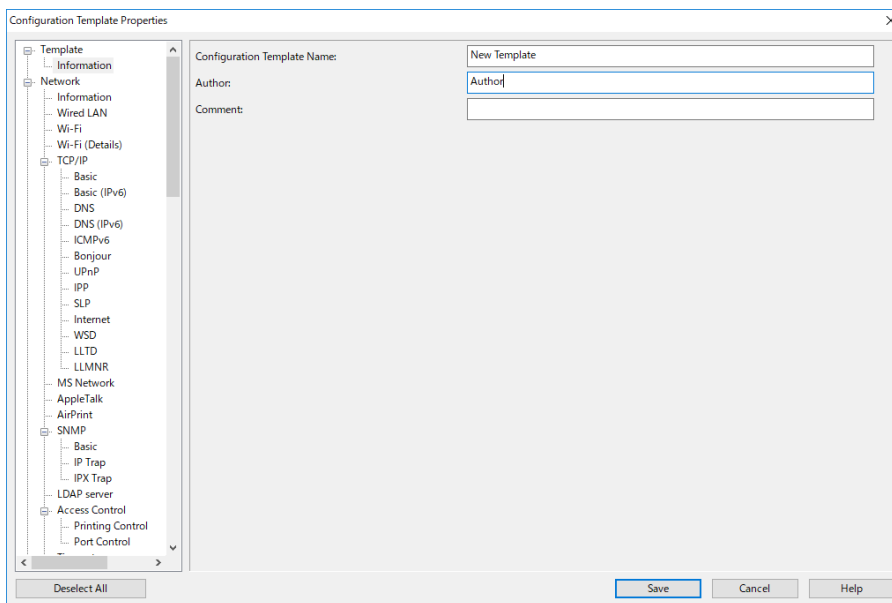

Item	Explanation
Configuration Template Name	Name of the configuration template. Enter up to 1,024 characters in Unicode (UTF-8).

Information Registration and System Configuration

Item	Explanation
Author	Information on the creator of the template. Enter up to 1,024 characters in Unicode (UTF-8).
Comment	Enter arbitrary information. Enter up to 1,024 characters in Unicode (UTF-8).

- Select the items you want to set on the left.

Note:

Click the menu items on the left to switch to each screen. The set value is retained if you switch the screen, but not if you cancel the screen. When you have finished all the settings, click **Save**.

Importing the License Key

- Select **Epson Open Platform Settings > Product key / License key** from the configuration template.
- Select the **Product key / License key List**.

If the **Epson Open Platform Version** is selected, deselect it.

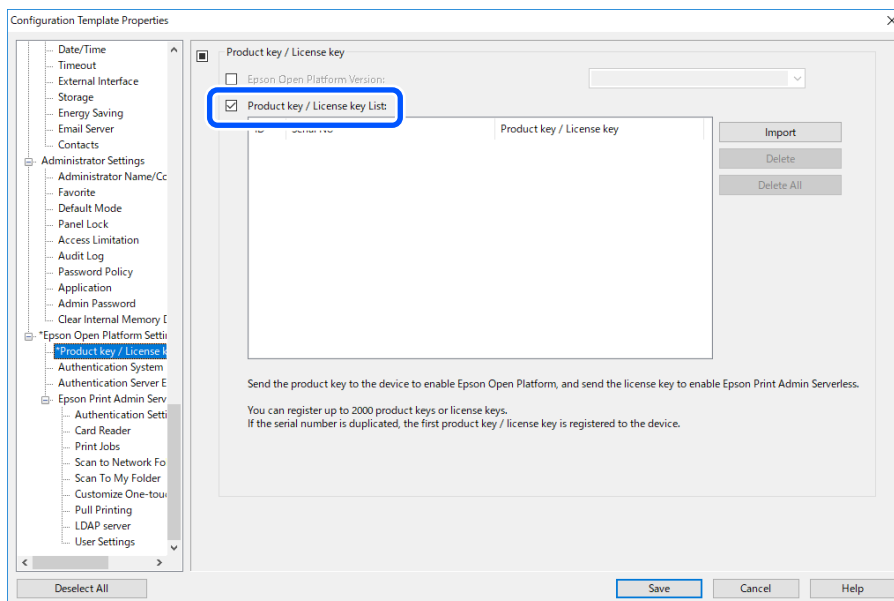

- Click **Import**.
- Select the CSV file for the license key and click **Open**.

The file is read and the contents are displayed.

Note:

- When you select the printer on the list and click **Delete**, you can delete the license key from the list.
- When you click **Import** again, you can add the other CSV files.

- Click **Save**.
- Click **OK**.

Information Registration and System Configuration

- Click **OK** on the completion screen.

Setting values are saved to the configuration template and then the screen is closed.

Note:

To open the configuration template again, select the saved template from the **Configuration Template Name**, and then click **Edit** on the ribbon menu.

Applying the Configuration Template

Apply the saved configuration template to the printer. The items selected on the template are applied. If the target printer does not have an applicable function, it is not applied.

Important:

If the administrator password has been set to the printer, make the password setting first.

1. Display the device list, and select **Options > Password manager**.
2. Select **Enable automatic password management** and then click **Password manager**.
3. Select the target printer, and then click **Edit**.
4. Set the password, and then click **OK**.

1. Select **Configuration** on the side bar task menu.

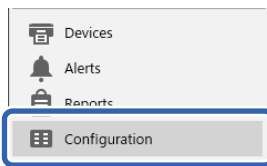

2. Select the configuration template you want to apply from **Configuration Template Name**.

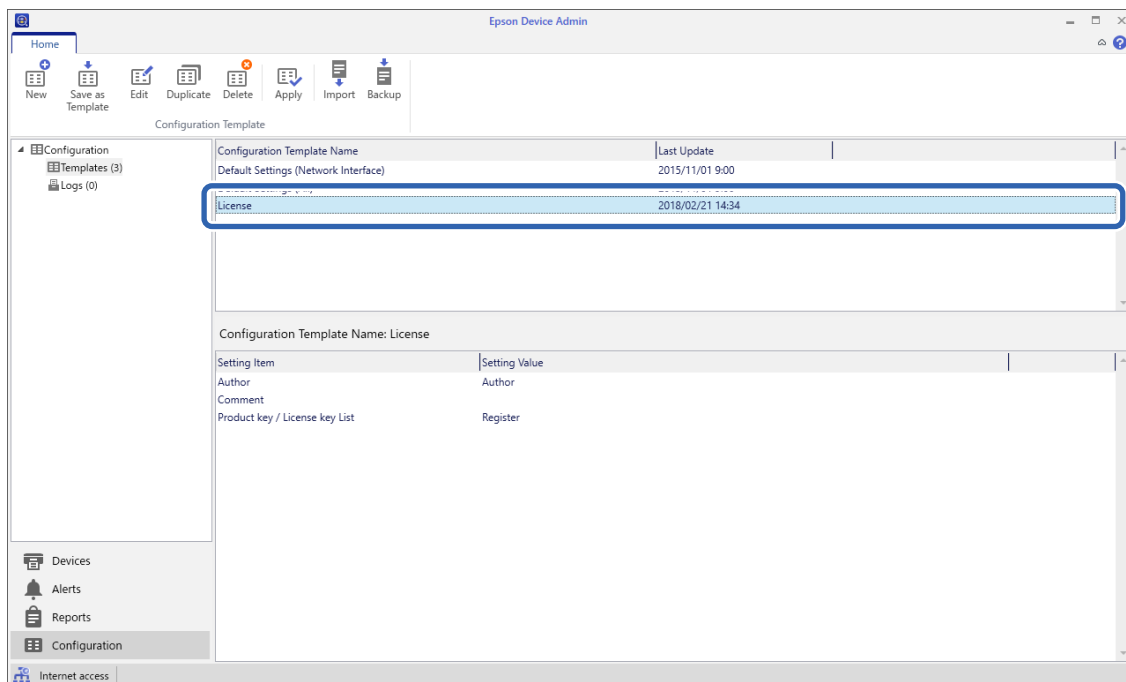

Information Registration and System Configuration

- Click **Apply** on the ribbon menu.

The device selection screen is displayed.



- Select the target to apply the configuration template.

Note:

- When you select **Devices** and groups containing devices from the pull-down menu, each device is displayed.
- Groups are displayed when you select **Groups**. Select **Include child group(s)** to automatically select child groups within the selected group.

- Move the devices or groups that you want to apply the template to **Selected Device/Group** by using [**>**], [**>>**], [**<**], [**<<**].

Use [**>**] to move the selected device or group, and use [**>>**] to move all devices or groups. To make multiple selections, press Ctrl or Shift and click your mouse.

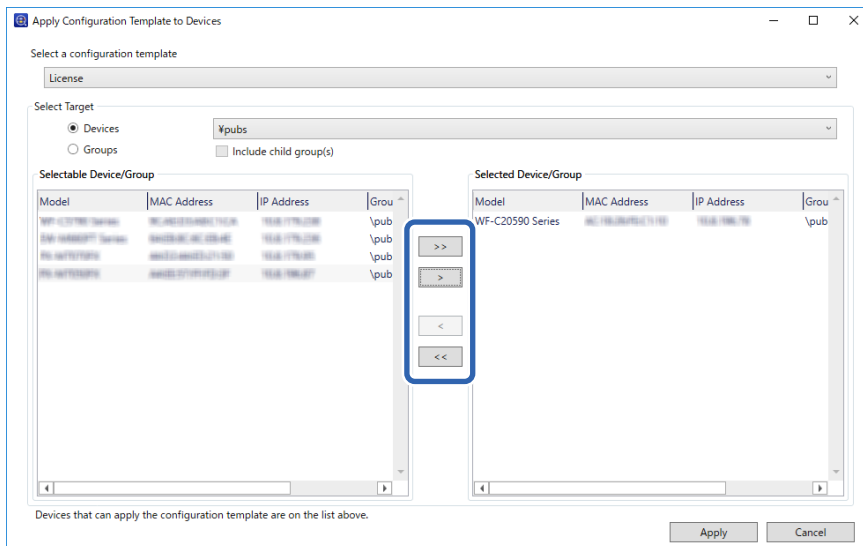

- Click **Apply**.

A confirmation screen for the configuration template to be applied is displayed.

- Click **OK**.

- Click **Details** and check the information.

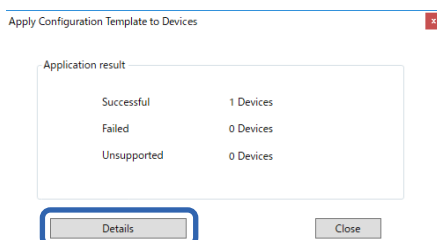

Information Registration and System Configuration

When is displayed on the items you applied, the application was completed successfully.

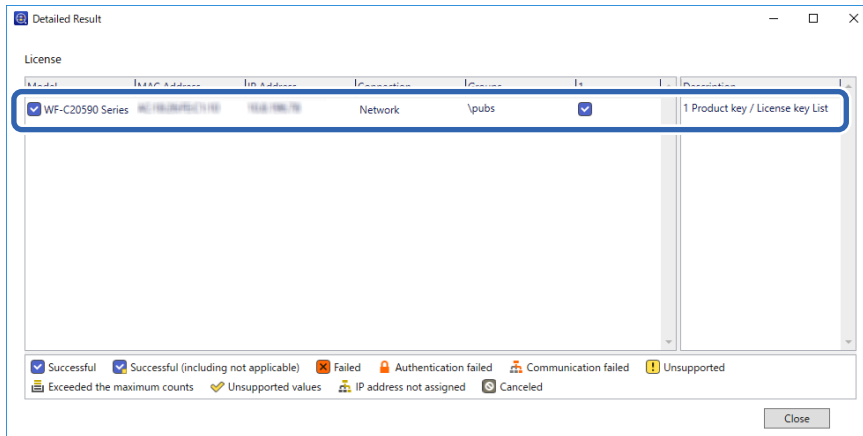

9. Click **OK**.

Note:

If you import the license key(s), check that the license was applied to the printer correctly by acquiring the device information.

Related Information

➔ [“Epson Device Admin” on page 11](#)

Set the Printer Individually Using Web Config

Explains the procedure when you set up Epson Print Admin Serverless to the printer individually.

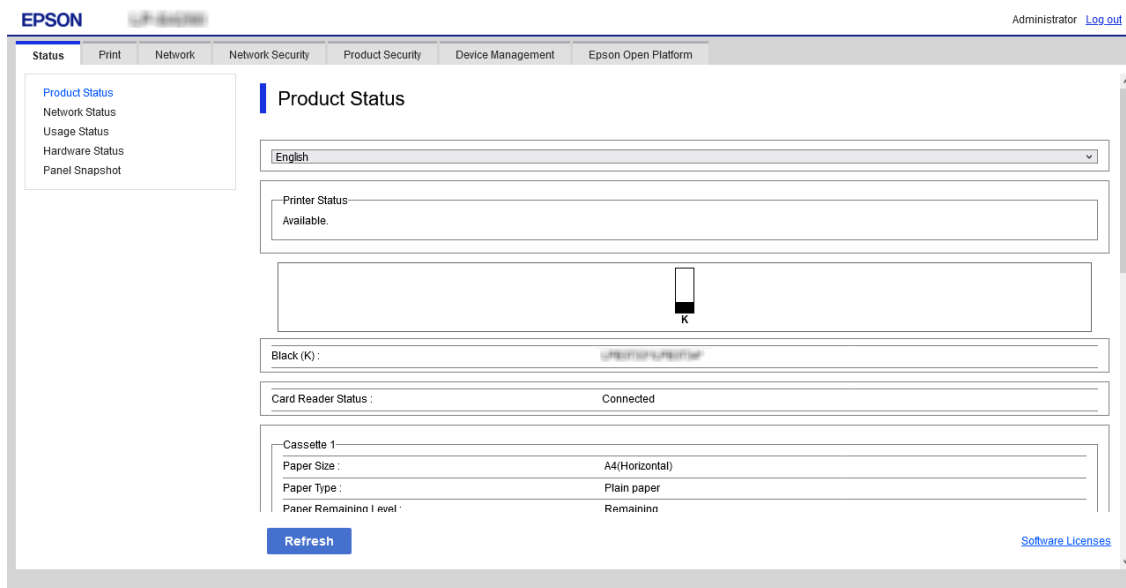

Make the necessary settings for Epson Print Admin Serverless depending on the authentication method you use. For details, see the related information.

Information Registration and System Configuration

Related Information

➔ [“Required Settings for the Authentication Method” on page 12](#)

Using Epson Print Admin Serverless Setting List

When registering the license key, the **Epson Print Admin Serverless Setting List** is displayed on the **Epson Open Platform** tab. Follow this list to make settings for Epson Print Admin Serverless.

1. Access Web Config and then select the **Epson Open Platform** tab > **Epson Print Admin Serverless Setting List**.

Setting items are displayed according to the authentication settings you selected in the **Epson Open Platform** tab > **Authentication Settings** > **Authentication Method**.

2. Click the link for the items you want to set.
3. Set each item.
4. Click **Epson Print Admin Serverless Setting List**.

Return to the **Epson Print Admin Serverless Setting List**.

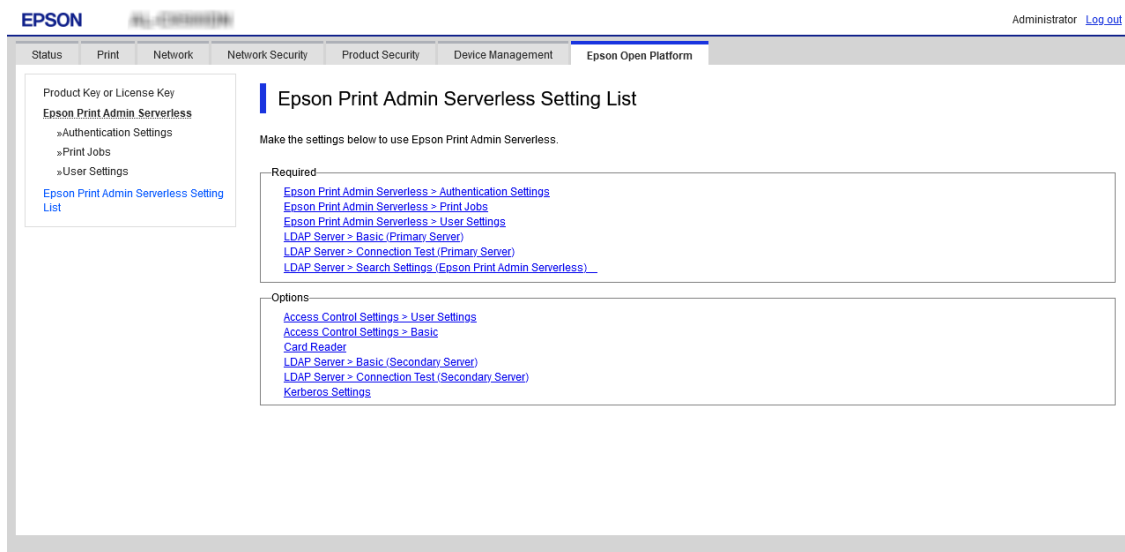

Making User Authentication Settings (Web Config)

Set the authentication method and how to authenticate user.

Information Registration and System Configuration

1. Select **Epson Print Admin Serverless Setting List > Epson Print Admin Serverless > Authentication Settings**.

Or access **Epson Open Platform tab > Authentication Settings**.

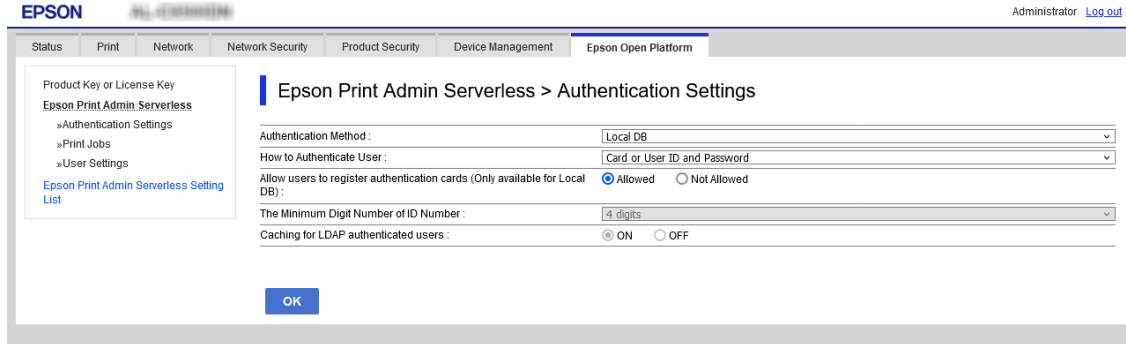

2. Set each item.
3. Click **OK**.

Authentication Setting Items

Item	Explanation
Authentication Method	<p>Select the authentication method.</p> <ul style="list-style-type: none"> <input type="checkbox"/> Local DB Authenticate using the user information registered to the printer. It is necessary to register the user information to the printer. <input type="checkbox"/> LDAP Authenticate using the user information of the LDAP server synchronized with the printer. It is necessary to set up the LDAP server. <input type="checkbox"/> Local DB and LDAP Authenticate using the user information registered to the printer or the LDAP server synchronized with the printer. It is necessary to register the user information to the printer and set up the LDAP server.
How to Authenticate User	<p>Select how to authenticate a user.</p> <ul style="list-style-type: none"> <input type="checkbox"/> Card or User ID and Password Use an ID card to authenticate users. You can also use a user ID and password to authenticate. <input type="checkbox"/> User ID and Password Use a user ID and password to authenticate users. You cannot use an ID card to authenticate when you select this function. <input type="checkbox"/> User ID Use only a user ID to authenticate users. You do not need to set a password. <input type="checkbox"/> Card or ID Number Use an ID card to authenticate users. You can also use an ID Number. <input type="checkbox"/> ID Number Use only an ID Number to authenticate users.

Information Registration and System Configuration

Item	Explanation
Allow users to register authentication cards	Enable it if you allow users to register the authentication card to the system. If you select LDAP for Authentication Method , you cannot set it.
The Minimum Digit Number of ID Number	Select the minimum number of digits for ID number.
Caching for LDAP authenticated users	When using LDAP server authentication, you can set whether or not to use caching for user information.

Important:

Notes when using LDAP server authentication:

When using an additional network interface board, the LDAP server can only be used with either the standard network interface or the additional network interface. Specify a network interface that can connect to the LDAP server used for LDAP server authentication.

Settings > General Settings > Network Settings > LDAP Server

Related Information

➔ [“Overview for the Authentication Method” on page 7](#)

Making Print Job Settings (Web Config)

Make settings related to the print job sent from the client computer.

1. Select the **Epson Print Admin Serverless Setting List > Epson Print Admin Serverless > Print Jobs**.
Or access **Epson Open Platform** tab > **Print Jobs**.

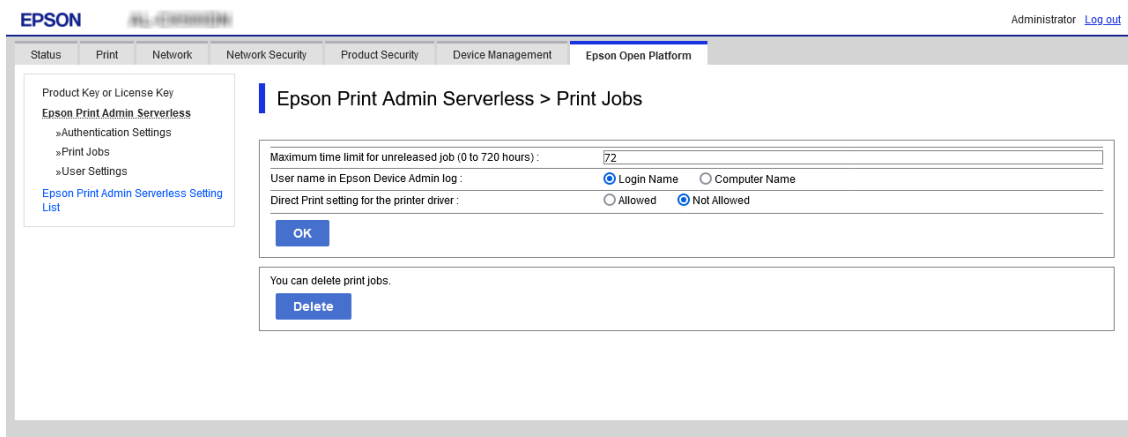

The screenshot shows the Epson Print Admin Serverless Web Config interface. The top navigation bar includes tabs for Status, Print, Network, Network Security, Product Security, Device Management, and Epson Open Platform. The left sidebar shows a tree view with 'Epson Print Admin Serverless' expanded to 'Print Jobs'. The main content area is titled 'Epson Print Admin Serverless > Print Jobs' and contains the following settings:

- Maximum time limit for unreleased job (0 to 720 hours):
- User name in Epson Device Admin log: Login Name Computer Name
- Direct Print setting for the printer driver: Allowed Not Allowed

There is an 'OK' button below the settings. Below the settings, there is a section titled 'You can delete print jobs.' with a 'Delete' button.

2. Set each item.
3. Click **OK**.

Related Information

➔ [“Deleting the Print Jobs” on page 73](#)

Information Registration and System Configuration

Print Jobs Setting Items

Item	Explanation
Maximum time limit for unreleased job (0 to 720 hours)	Set the time period to automatically delete all print jobs. When you set "0", the print jobs will not be deleted automatically.
User name in Epson Device Admin log	<p>You can select the name to be recorded in [Print: user name] in the job history report output by Epson Device Admin.</p> <p><input type="checkbox"/> Login Name: Records the user name logged in to Epson Print Admin Serverless.</p> <p><input type="checkbox"/> Computer Name: Records the computer name that sent the print job to Epson Print Admin Serverless.</p>
Direct Print setting for the printer driver	<p>Allows printing without storing print jobs when printing from a computer. When this is selected, the user can print directly without logging in to the printer if the print job's authentication information matches the authentication information for the device or the LDAP server.</p> <p>In the printer driver, the user sets whether or not to store print jobs.</p>

Registration for the User Information (Web Config)

Register the user information that is used to user authentication.

When you select **LDAP** for **Authentication Method**, you do not need to register the users. In that case, **User Settings** is not displayed on the list.

When you select **Local DB and LDAP** for **Authentication Method**, make the LDAP server setting together.

Registering the User Information Individually

Enter the user information one by one.

1. Select the **Epson Print Admin Serverless Setting List > Epson Print Admin Serverless > User Settings**.
Or access **Epson Open Platform** tab > **User Settings**.

Information Registration and System Configuration

2. Click **Add**.

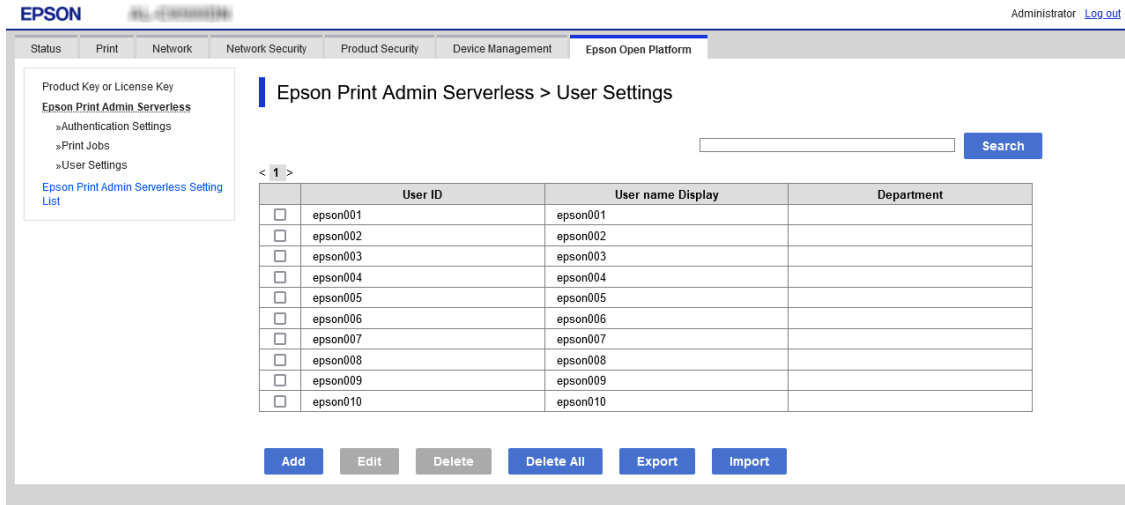

3. Set each item.

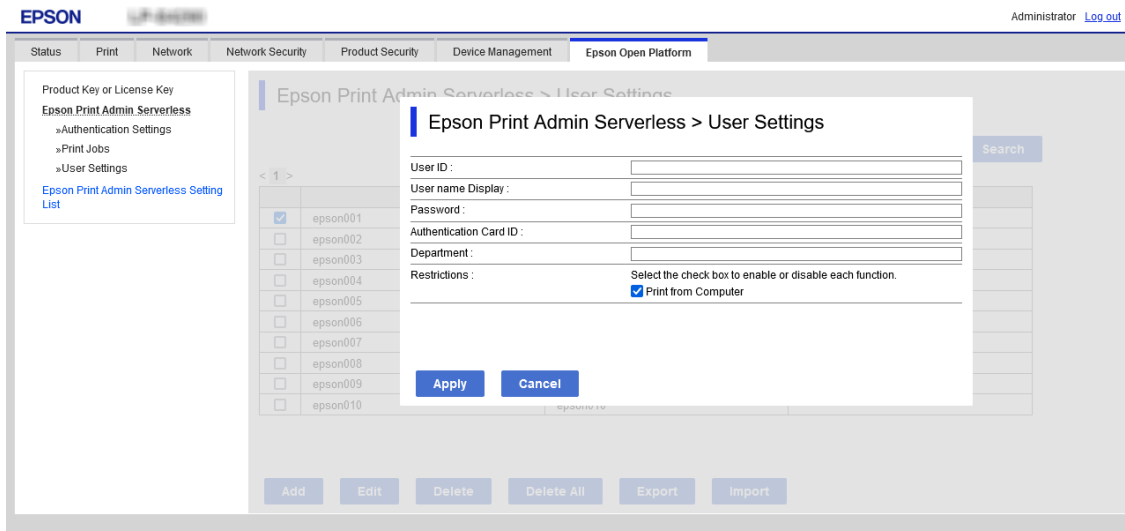

4. Click **Apply**.

5. Click **Close**.

User Information Setting Items

Item	Explanation
User ID	Enter the user ID to use authentication between 1 and 83 bytes in Unicode. Since the User ID is not case sensitive, you can login using upper or lower case letters.
User name Display	Enter the user name displayed on the printer's control panel within 32 characters in Unicode. You can leave this blank.

Information Registration and System Configuration

Item	Explanation
Password	Enter the password to use authentication within 32 characters in ASCII. The password is case sensitive. Leave this blank if you select How to Authenticate User for User ID .
Authentication Card ID	Set the reading result of ID card. When you permit the Allow users to register authentication cards for Authentication Settings , the result registered by users is reflected. Enter within 116 characters in ASCII. You can leave this blank.
ID Number	It is displayed when Epson Open Platform or Authentication Settings is selected on How to Authenticate User tab > Card or ID Number > ID Number . Enter the number between 4 and 8 digits depending on the digits set on Epson Open Platform tab > Authentication Settings > The Minimum Digit Number of ID Number .
Auto Generate	It is displayed when Epson Open Platform or Authentication Settings is selected on How to Authenticate User tab > Card or ID Number > ID Number . Click to generate the ID number automatically that the digit is same as the The Minimum Digit Number of ID Number you set.
Department	Enter the department name arbitrary to distinguish the users. You can leave this blank.
Restrictions	You can restrict functions for each user. Select the functions you want to allow in Select the check box to enable or disable each function .

Registering the User Information in Bulk by Using CSV File

You can register users in bulk using a CSV file.

1. Select the **Epson Print Admin Serverless Setting List** > **Epson Print Admin Serverless** > **User Settings**.
Or access **Epson Open Platform** tab > **User Settings**.
2. Click **Import**.

The screenshot shows the Epson Print Admin Serverless User Settings page. The breadcrumb navigation is **Epson Print Admin Serverless > User Settings**. A search bar is present above the table. The table lists 10 users with columns for User ID, User name Display, and Department. At the bottom of the table, there are buttons for **Add**, **Edit**, **Delete**, **Delete All**, **Export**, and **Import**. The **Import** button is highlighted with a red box.

	User ID	User name Display	Department
<input type="checkbox"/>	epson001	epson001	
<input type="checkbox"/>	epson002	epson002	
<input type="checkbox"/>	epson003	epson003	
<input type="checkbox"/>	epson004	epson004	
<input type="checkbox"/>	epson005	epson005	
<input type="checkbox"/>	epson006	epson006	
<input type="checkbox"/>	epson007	epson007	
<input type="checkbox"/>	epson008	epson008	
<input type="checkbox"/>	epson009	epson009	
<input type="checkbox"/>	epson010	epson010	

Information Registration and System Configuration

3. Click **Browse...** to select the file to import, and then click **Open**.

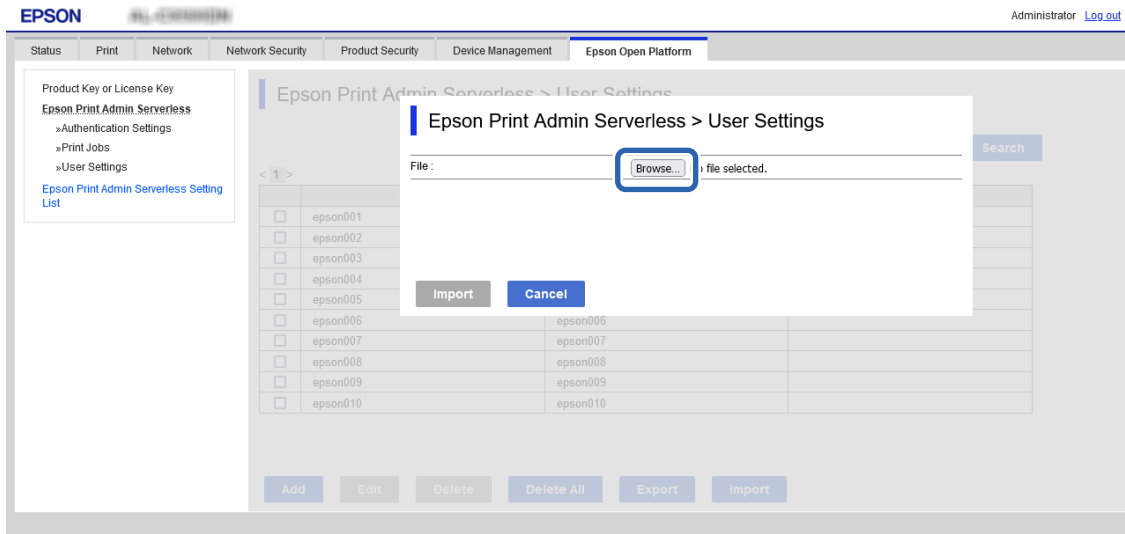

4. Click **Import**.
5. After checking the displayed information, click **OK**.

Related Information

➔ [“Creating the CSV File” on page 35](#)

Creating the CSV File

Create the CSV file to import the user information.

You can easily create the CSV file by using the user information registered individually. We recommend registering the user information individually in advance.

1. Select the **Epson Print Admin Serverless Setting List > Epson Print Admin Serverless > User Settings**.
Or access the **Epson Open Platform** tab > **User Settings**.

2. Click **Export**.

3. Select the file format for **File Format**.

Select it by referring below.

Item	Explanation
CSV UTF-16 (Tab delimited)	Select when you edit the file using Microsoft Excel. Each parameter is enclosed by "[]"(brackets). Enter the parameters in "[]". When you update the file, we recommend overwriting the file. If you newly save the file, select Unicode text(*.txt) for the file format.

Information Registration and System Configuration

Item	Explanation
CSV UTF-8 (Comma delimited)	Select when you edit the file using a text editor or macro without Microsoft Excel.
CSV UTF-8 (Semicolon delimited)	

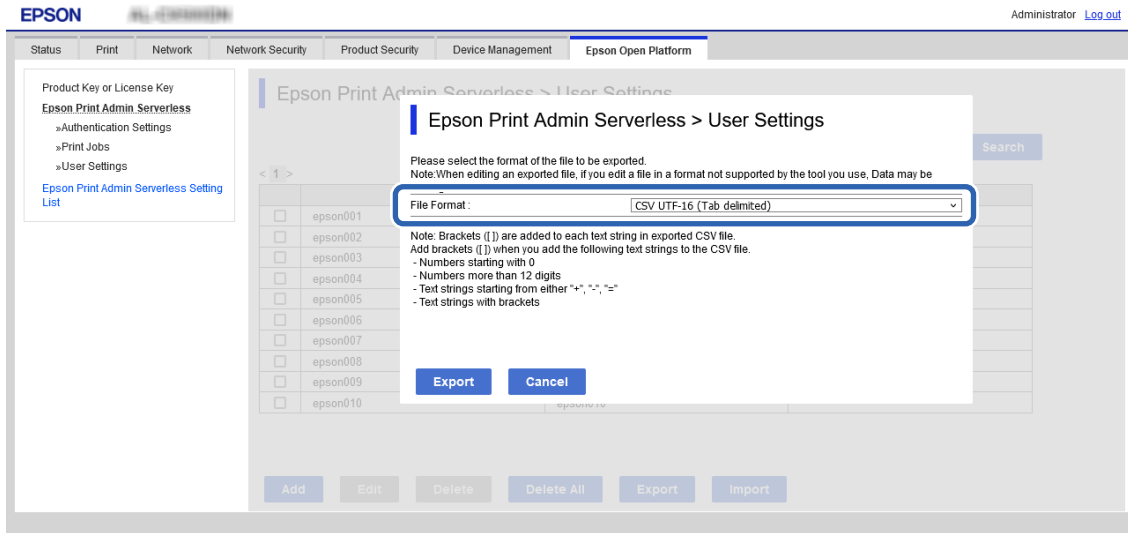

- Click **Export**.
- Select the location to save the file, and then click **Save**.
The file is saved.
- Edit the CSV file you saved in a spreadsheet application such as Microsoft Excel or in a text editor, and then save the information.



Important:

When editing the file, do not change the encoding and header information.

CSV File Setting Items

Item	Settings and Explanation
UserID	Enter the user ID to use authentication between 1 and 83 bytes in Unicode.
UserName	Enter the user name displayed on the printer's control panel within 32 characters in Unicode. You can leave this blank.
Password	Enter the password to use authentication within 32 characters in ASCII. When importing, this is set as the password instead of [EncPassword]. Leave this blank if you select User ID for How to Authenticate User . When exporting, this is always blank.
AuthenticationCardID	Set the reading result of ID card. When you permit the Allow users to register authentication cards for Authentication Settings , the result registered by users is reflected. Enter within 116 characters in ASCII. You can leave this blank.

Information Registration and System Configuration

Item	Settings and Explanation
IDNumber	<p>It is displayed when Card or ID Number or ID Number is selected on Epson Open Platform tab > Authentication Settings > How to Authenticate User.</p> <p>Enter the number between 4 and 8 digits depending on the digits set on Epson Open Platform tab > Authentication Settings > The Minimum Digit Number of ID Number.</p> <p>An ID Number cannot be duplicated. If it is duplicated, you will be alerted to the error when importing the file. When left blank, it is automatically assigned a number.</p>
Department	<p>Enter the department name arbitrary to distinguish the users.</p> <p>Enter within 40 characters in Unicode (UTF-8). You can leave this blank.</p>
EncPassword	<p>When exporting, the parameter set for [Password] is encrypted using BASE64 and then output.</p> <p>When importing and entering a new password in [Password], this is ignored.</p> <p>If [Password] is blank, this value is used and the password remains as it was before exporting.</p>
ComPrint	<p>Settings to enable or disable the print from the computer function. Enable: 1, Disable: 0</p>

Related Information

➔ [“Importing from CSV / ENE File” on page 51](#)

Synchronization with the LDAP Server (Web Config)

Make the LDAP server settings for the printer using Web Config.

Set it when you select **LDAP** or **Local DB and LDAP** for **Authentication Method**.

For details of setting items, see the same item for Epson Device Admin in this manual.

Related Information

➔ [“LDAP Server Setting Items” on page 48](#)

➔ [“Kerberos Setting Items” on page 50](#)

➔ [“Search Setting Items” on page 50](#)

Information Registration and System Configuration

Making the LDAP Server Setting (Web Config)

1. Select the **Epson Print Admin Serverless Setting List > LDAP Server > Basic (Primary Server)**.
Or access **Network** tab > **LDAP Server > Basic (Primary Server)**.

The screenshot shows the Epson Print Admin Web Config interface. The breadcrumb trail is **LDAP Server > Basic (Primary Server)**. The form contains the following fields:

- Use LDAP Server:** Use Do Not Use
- LDAP Server Address:** 192.0.2.111
- LDAP server Port Number:** 389
- Secure Connection:** None
- Certificate Validation:** Enable Disable
- Search Timeout (sec):** 30
- Authentication Method:** Anonymous Authentication
- Kerberos Realm to be Used:** Not Set
- Administrator DN / User Name:**
- Password:**

Below the form, there is a note: "The certificate is required to use a secure function of the LDAP server. Make settings on the following page. - CA Certificate". At the bottom of the form, there is an **OK** button.

2. Set each item.
See the related information for details of each item.
3. Click **OK**.
4. When you select **Kerberos Authentication** for **Authentication Method**, make Kerberos settings from **Network** tab > **Kerberos Settings**, and then click **OK**.
You can register up to 10 Kerberos settings. If you do not select it, go to the next step.
5. Set the secondary server for LDAP server as necessary on **Basic (Secondary Server)**, and then click **OK**.
The setting items are same as the primary server settings.
6. Click **OK**.

Related Information

- ➔ [“LDAP Server Setting Items” on page 48](#)
- ➔ [“Kerberos Setting Items” on page 50](#)

Checking the LDAP Server Connection

Performs the connection test to the LDAP server by using the parameter set on **LDAP Server > Search Settings**.

1. Select the **Epson Print Admin Serverless Setting List > LDAP Server > Connection Test (Primary Server)**.
Or access **Network** tab > **LDAP Server > Connection Test (Primary Server)**.

Information Registration and System Configuration

2. Click **Start**.
The result is displayed.
3. Click **OK**.

Making the Search Attribute Setting

Set the search attribute of the user to register to Epson Print Admin Serverless from the LDAP server.

1. Select the **Epson Print Admin Serverless Setting List > LDAP Server > Search Settings (Epson Print Admin Serverless)**.
Or access **Network** tab > **LDAP Server > Search Settings (Epson Print Admin Serverless)**.

The screenshot shows the Epson Print Admin Serverless web interface. The top navigation bar includes tabs for Status, Print, Network, Network Security, Product Security, Device Management, and Epson Open Platform. The current page is titled "LDAP Server > Search Settings (Epson Print Admin Serverless)". On the left, there is a sidebar menu with options like "Product Key or License Key", "Epson Print Admin Serverless", "Authentication Settings", "Print Jobs", "User Settings", and "Epson Print Admin Serverless Setting List". The main content area contains several input fields for LDAP search attributes:

Search Base (Distinguished Name) :	<input type="text" value="OU=Accounts,dc=Pubs,dc-net"/>
User ID Attribute :	<input type="text" value="sAMAccountName"/>
User name Display Attribute :	<input type="text" value="displayName"/>
Authentication Card ID Attribute :	<input type="text" value="pager"/>
ID Number Attribute :	<input type="text" value="employeeNumber"/>
Department Attribute :	<input type="text" value="department"/>

An "OK" button is located at the bottom of the form.

2. Set each item.
3. Click **OK**.

Related Information

➔ [“Search Setting Items” on page 50](#)

Options Functions Setting (Web Config)

Set when you use functions other than authentication printing.

Access Control Settings

Set the functions that are available to the user.

Making Available Function Settings (Web Config)

Set the functions that are available to the registered user when logging in to Epson Print Admin Serverless.

Note:

When you use device authentication in Epson Print Admin Serverless, you can also set access restrictions for each user in User Settings for Web Config. See related information for details on the setting items.

Information Registration and System Configuration

1. Select the **Epson Print Admin Serverless Setting List > Access Control Settings > User Settings**.
Or access **Product Security** tab > **Access Control Settings > User Settings**.
2. Click **Edit** next to 1.

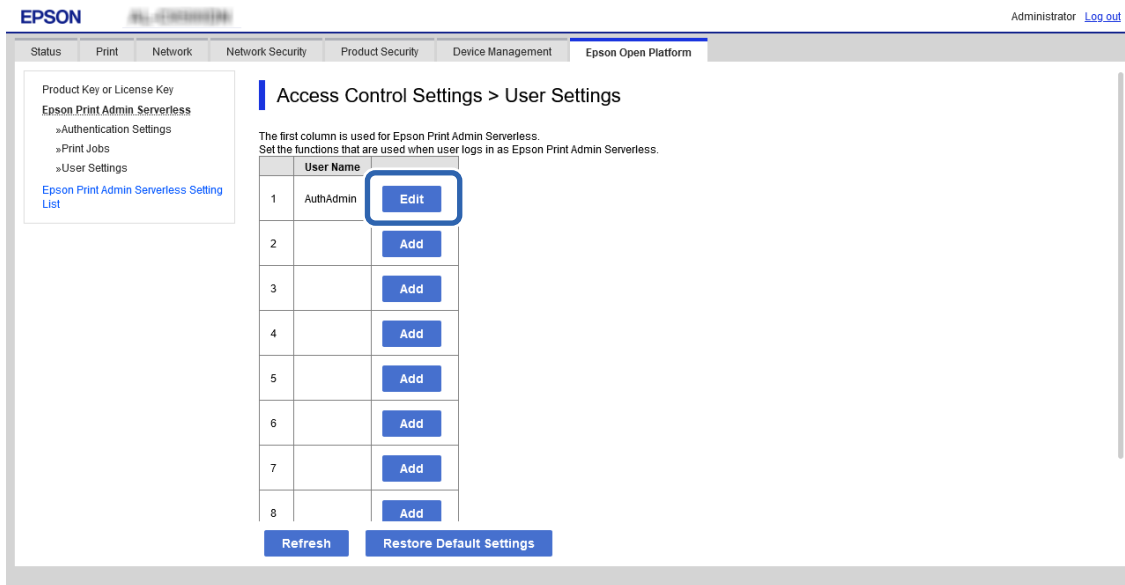

3. Enable the functions that you want to permit to use in **Select the check box to enable or disable each function..**

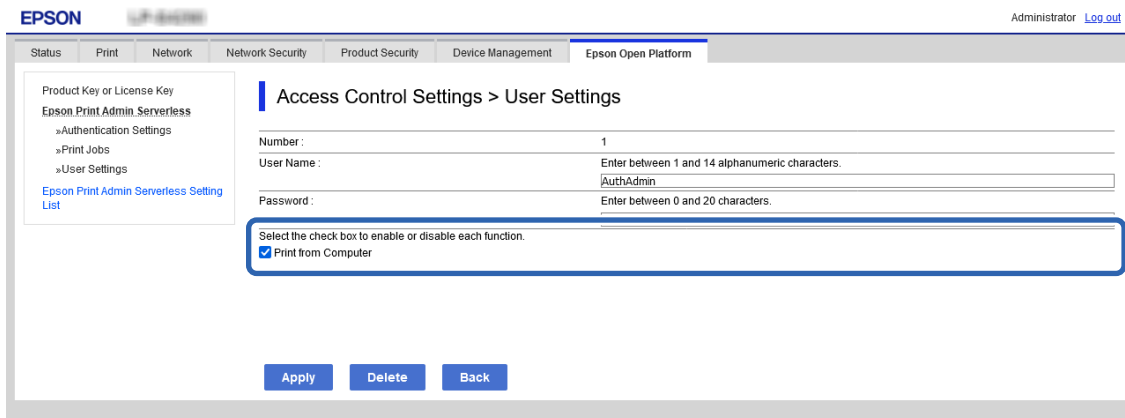

4. Click **Apply**.

Related Information

➔ [“User Information Setting Items” on page 33](#)

Allow printer to be used from drivers and software

Set permissions such as printing without using authentication information and logging in to Web Config for registered users.

Information Registration and System Configuration

Allow print jobs without authentication information (Web Config)

1. Select **Access Control Settings > Basic** from **Epson Print Admin Serverless Setting List**.
Or access the **Product Security** tab > **Access Control Settings > Basic**.
2. Select **Allow printing and scanning without authentication information from a computer**.

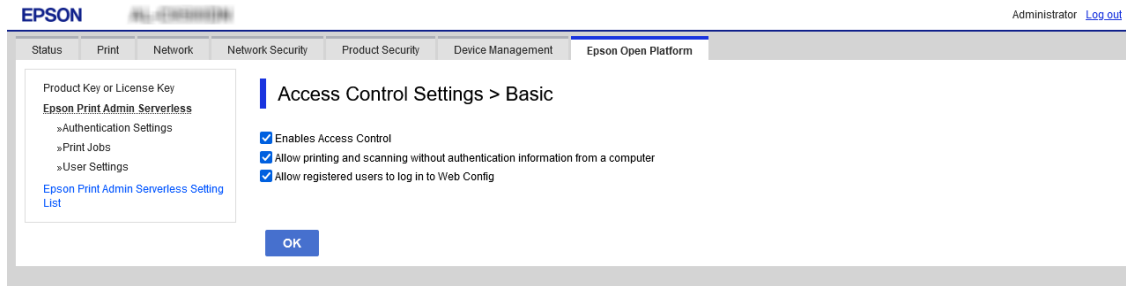

3. Click **OK**.

Allow registered users to log in to Web Config (Web Config)

1. Select **Access Control Settings > Basic** from **Epson Print Admin Serverless Setting List**.
Or access the **Product Security** tab > **Access Control Settings > Basic**.
2. Select **Allow registered users to log in to Web Config**.

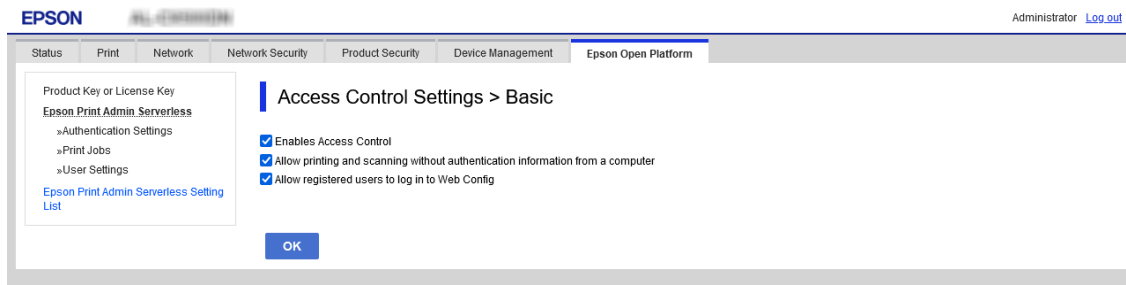

3. Click **OK**.

Making Authentication Device Settings (Web Config)

Set the reading format for authentication information received from an ID card.

1. Select the **Epson Print Admin Serverless Setting List > Card Reader**.
Or access **Device Management** tab > **Card Reader**.

Information Registration and System Configuration

- Set the reading information of the authentication device and ID card.
See the related information for the details of each item.

The screenshot shows the Epson Device Admin web interface. The top navigation bar includes 'Status', 'Print', 'Network', 'Network Security', 'Product Security', 'Device Management', and 'Epson Open Platform'. The left sidebar contains a menu with 'Product Key or License Key', 'Epson Print Admin Serverless', '»Authentication Settings', '»Print Jobs', '»User Settings', and 'Epson Print Admin Serverless Setting List'. The main content area is titled 'Card Reader' and contains the following configuration fields:

- Vendor ID: 0000
- Product ID: 0000
- Operational parameter: (empty field)
- Epson Print Admin Serverless:
 - Card Reader: Custom (Format 7)
 - Authentication Card ID save format: Format 1 (Default)
- Set card ID range
- Text Start Position: 1
- Number of Characters: 1

At the bottom of the configuration area, there is a 'Next' button. Below the configuration area, there is a section for checking the card reader connection and the card reading result, with a 'Check' button.

- Click **Next**.
The setting confirmation screen is displayed.
- Click **OK**.

Related Information

- ➔ [“Available Reading Method for Authentication Information” on page 20](#)

Batch Setting Using Epson Device Admin (Configuration Template)

When using Epson Device Admin, you can set Epson Print Admin Serverless settings to multiple printers in bulk. For details, see the manual or help for Epson Device Admin.

Information Registration and System Configuration

Make the necessary settings for the Epson Print Admin Serverless depending on the authentication method you use. For details, see the related information.

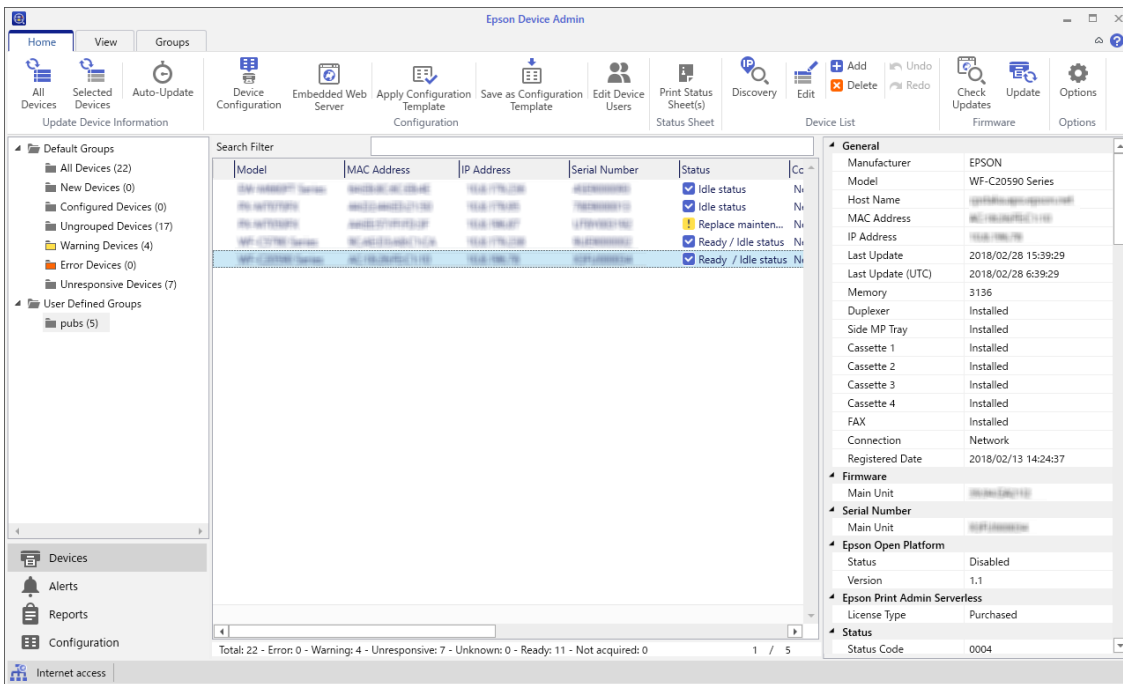

Related Information

➔ [“Required Settings for the Authentication Method” on page 12](#)

Operation Flow of Epson Device Admin

Make the Epson Print Admin Serverless settings by using the configuration template for Epson Device Admin. Apply the setting value to the printer by following the flow below.

1. Create the configuration template.

Information Registration and System Configuration

- On the setting item screen, enter or select the value, and enable the item that you want to apply.
The following is an example.

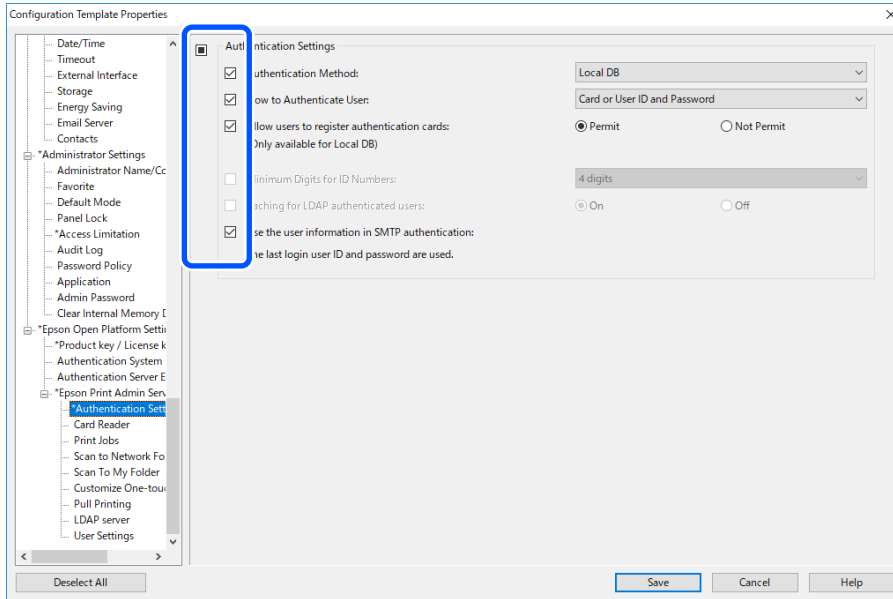

- Save the configuration template.
- Select the printer you want to apply the setting value, and apply the configuration template.

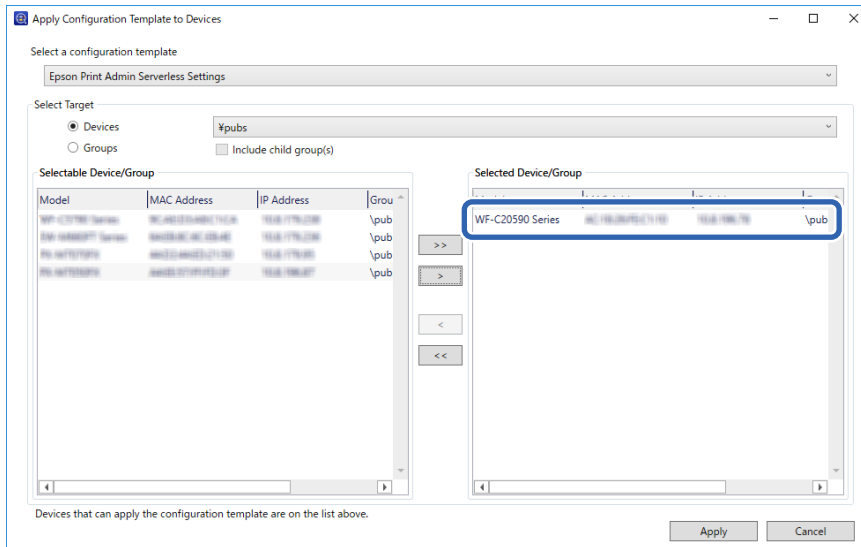

For the basic operation of the configuration template, see the related information.

Related Information

- ➔ “Creating the Configuration Template” on page 24
- ➔ “Applying the Configuration Template” on page 26

Information Registration and System Configuration

Making User Authentication Settings (Configuration Template)

Set the authentication method and how to authenticate user.

1. Select **Epson Open Platform Settings > Epson Print Admin Serverless Settings > Authentication Settings** from the configuration template.

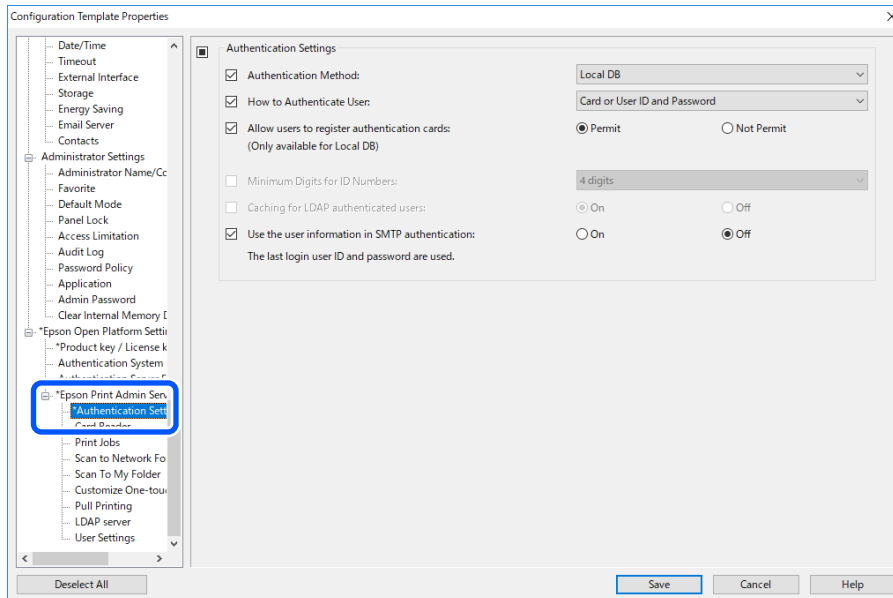

2. Set each item.

See the related information for the items.

Related Information

➔ [“Authentication Setting Items” on page 30](#)

Making Authentication Device Settings (Configuration Template)

Set the reading format for authentication information received from an ID card.

Information Registration and System Configuration

1. Select **Epson Open Platform Settings > Epson Print Admin Serverless Settings > Card Reader** from the configuration template.

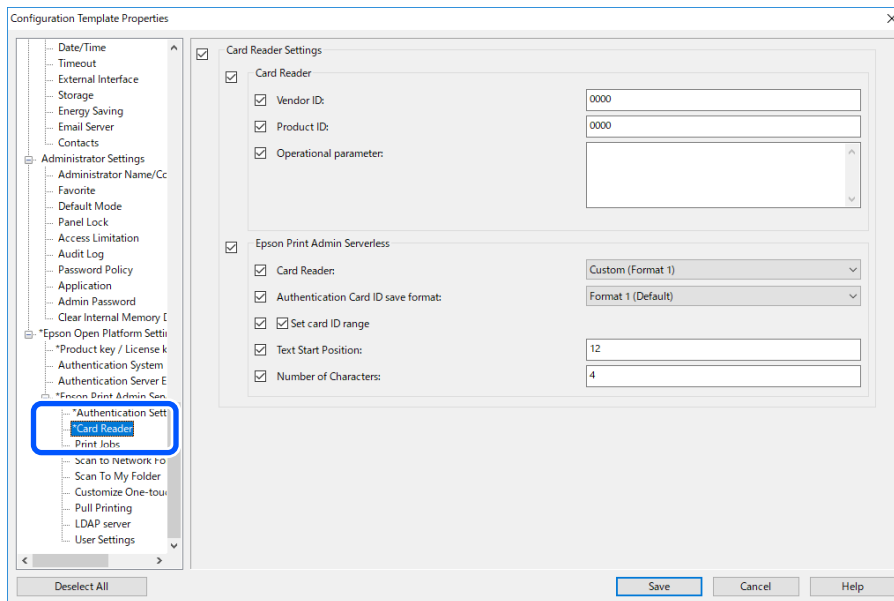

2. Set the reading information of the authentication device and ID card.
See the related information for the items.

Related Information

- ➔ [“Available Reading Method for Authentication Information”](#) on page 20

Making Print Job Settings (Configuration Template)

Make settings related to the print job sent from the client computer.

Information Registration and System Configuration

1. Select **Epson Open Platform Settings > Epson Print Admin Serverless Settings > Print Jobs** from the configuration template.

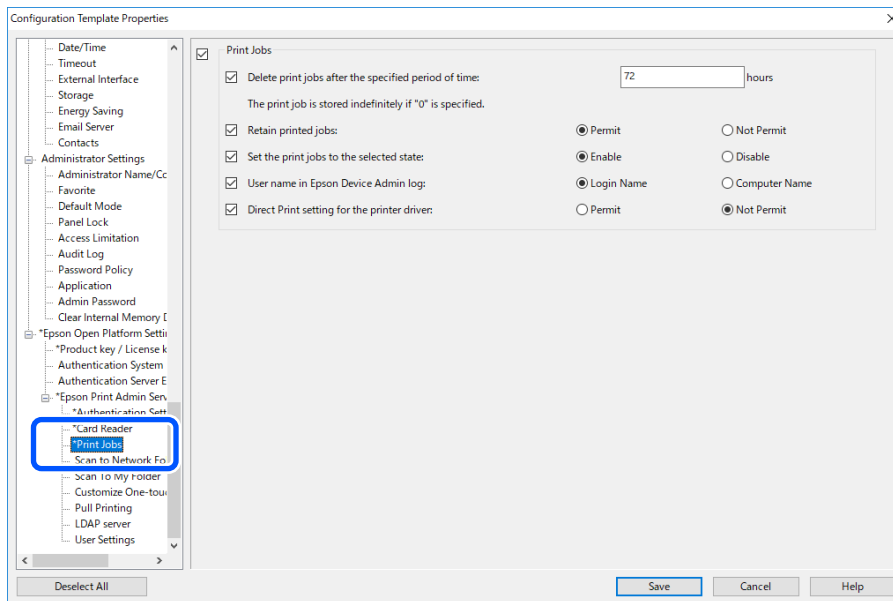

2. Set each item.

See the related information for the items.

Related Information

➔ [“Print Jobs Setting Items” on page 32](#)

Synchronizing with the LDAP Server (Configuration Template)

Set the LDAP server setting used by the authentication method for **LDAP** or **Local DB and LDAP**, and search the attribute setting used to identify the user information.

It can be used as a redundant system of the LDAP server.

Note:

*The LDAP server settings that are set here are shared with the settings for **Network > LDAP Server > Server Settings (Primary Server)** and **Server Settings (Secondary Server)** used by **Contacts**. When you change one value, it is reflected in the other.*

Information Registration and System Configuration

1. Select **Epson Open Platform Settings > Epson Print Admin Serverless Settings > LDAP Server** from the configuration template.

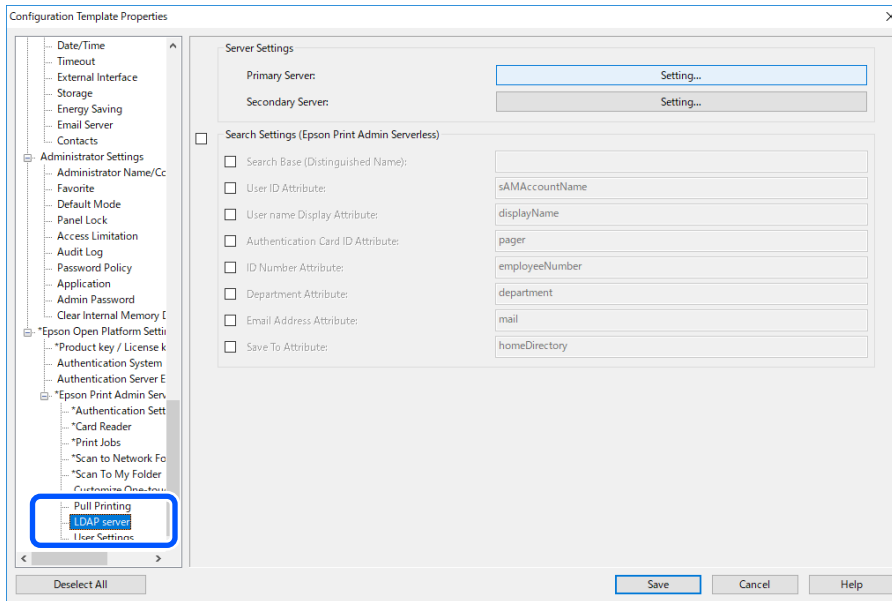

2. Set each item.
See the related information for the items.

Related Information

- ➔ “LDAP Server Setting Items” on page 48
- ➔ “Kerberos Setting Items” on page 50
- ➔ “Search Setting Items” on page 50

LDAP Server Setting Items

Click **Settings** for **Server Settings (Primary Server)**.

When you select **Kerberos Authentication** for **Authentication Method**, make Kerberos settings from **Network > Security > Kerberos Settings**.

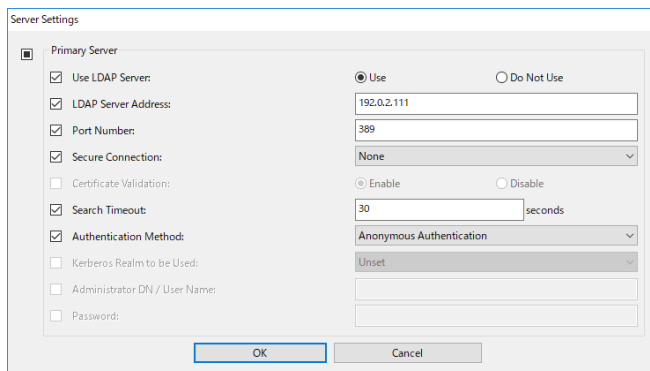

Information Registration and System Configuration

Item	Settings and Explanation
Use LDAP Server	Select when you use LDAP server.
LDAP Server Address	Enter the address of the LDAP server. Enter between 1 and 1024 characters of either IPv4, IPv6, or FQDN format. For the FQDN format, you can use alphanumeric characters in ASCII (0x20-0x7E) and "-" except for the beginning and end of the address.
Port Number	Enter the LDAP server port number between 1 and 65535.
Secure Connection	Specify the authentication method when the printer accesses the LDAP server.
Certificate Validation	When this is enabled, the certificate of the LDAP sever is validated. We recommend this is set to Enabled . To set up, the CA Certificate needs to be imported to the printer.
Search Timeout	Set the length of time for searching before timeout occurs between 0 and 99999.
Authentication Method	Select one of the methods. If you select Kerberos Authentication , select Kerberos Settings to make Kerberos settings. To perform Kerberos Authentication, the following environment is required. <ul style="list-style-type: none"> <input type="checkbox"/> The printer and the DNS server can communicate. <input type="checkbox"/> The time of the printer, KDC server, and the server that is required for authentication (LDAP server, SMTP server, File server) are synchronized. <input type="checkbox"/> When the service server is assigned as the IP address, the FQDN of the service server is registered on the DNS server reverse lookup zone.
Kerberos Realm to be Used	If you select Kerberos Authentication for Authentication Method , select the Kerberos realm that you want to use.
Administrator DN / User Name	Enter the user name for the LDAP server in 1024 characters or less in Unicode (UTF-8). You cannot use control characters, such as 0x00-0x1F and 0X7F. This setting is not used when Anonymous Authentication is selected as the Authentication Method . If you do not specify this, leave it blank.
Password	Enter the password for the LDAP server authentication in 1024 characters or less in Unicode (UTF-8). You cannot use control characters, such as 0x00- 0x1F and 0X7F. This setting is not used when Anonymous Authentication is selected as the Authentication Method . If you do not specify this, leave it blank.

Related Information

➔ [“Importing from the LDAP Server” on page 53](#)

Information Registration and System Configuration

Kerberos Setting Items

Select Network > Security > Kerberos Settings.

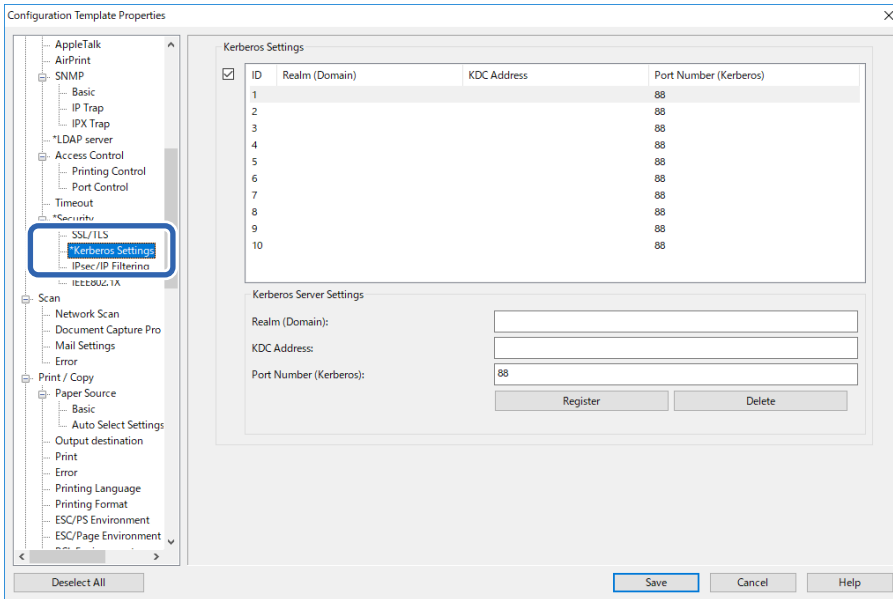

Item	Settings and Explanation
Realm (Domain)	Enter the realm of the Kerberos authentication in 1024 characters or less in ASCII. If you do not register this, leave it blank.
KDC Address	Enter the address of the Kerberos authentication server. Enter 1024 characters or less in either IPv4, IPv6 or FQDN format. If you do not register this, leave it blank.
Port Number (Kerberos)	Enter the Kerberos server port number between 1 and 65535.

Search Setting Items

Set the search attribute of the users to synchronize with the LDAP server authentication.

Search Setting

Item	Settings and Explanation
Search Base (Distinguished Name)	Specify the start position for searching the user information when you search it from the LDAP server. Enter between 0 and 128 characters in Unicode (UTF-8). If you do not search for arbitrary attribute, leave this blank. Example for the local server directory: dc=server,dc=local
User ID Attribute	Specify the attribute name to display when searching for the user ID. Enter between 1 and 255 characters in ASCII. The first character should be a-z or A-Z. Example: cn, uid
User name Display Attribute	Specify the attribute name to display as the user name. Enter between 0 and 255 characters in ASCII. The first character should be a-z or A-Z. You can leave this blank. Example: cn, name

Information Registration and System Configuration

Item	Settings and Explanation
Authentication Card ID Attribute	Specify the attribute name to display as the authentication card ID. Enter between 0 and 255 characters in ASCII. The first character should be a-z or A-Z. You can leave this blank. Example: cn, sn
ID Number Attribute	Specify the attribute name to display when searching for the ID number. Enter between 1 and 255 characters in ASCII. The first character should be a-z or A-Z. Example: cn, id
Department Attribute	Specify the attribute name to display as the department name. Enter between 0 and 255 characters in ASCII. The first character should be a-z or A-Z. You can leave this blank. Example: ou, ou-cl

Related Information

- ➔ [“Synchronization with the LDAP Server \(Web Config\)” on page 37](#)
- ➔ [“Importing from the LDAP Server” on page 53](#)

Registration for the User Information (Configuraiton Template)

Register the user information that is used to user authentication.

When you select **LDAP** for **Authentication Method**, you do not need to register the users.

Import for the User Information (Configuration Template)

You can import user information to the printer in bulk by using the LDAP server or CSV/ENE file.

Search the user information from the LDAP server for Epson Print Admin Serverless, and then import it to the printer.

You can import user information up to the number of users that have not already been assigned in Contacts.

Note:

ENE file is the binary file provided by Epson that encrypts and saves the Contacts or user information. It can be exported from Epson Device Admin and a password can be set. It is useful when you want to import the user information from the backup file.

Importing from CSV / ENE File

1. Select **Epson Open Platform Settings > Epson Print Admin Serverless Settings > User Settings**.

Information Registration and System Configuration

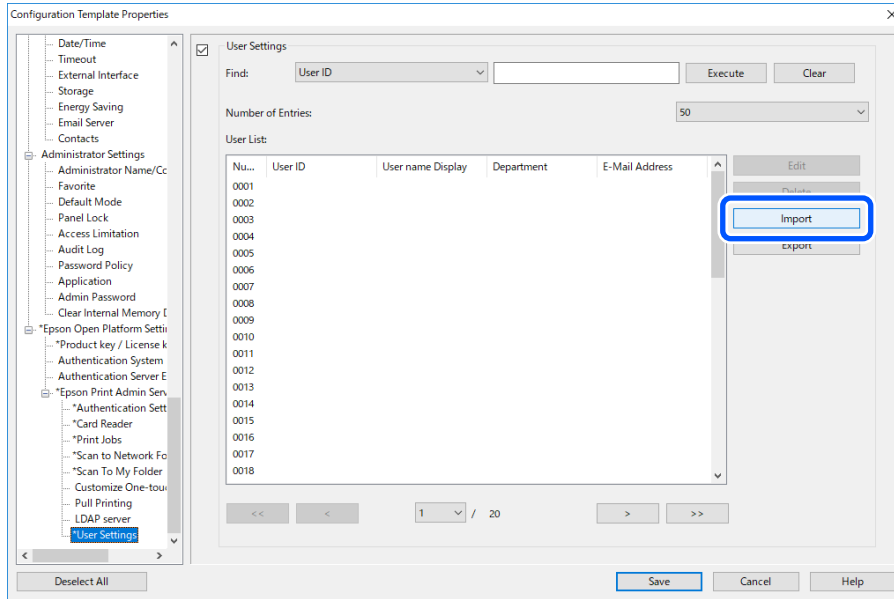
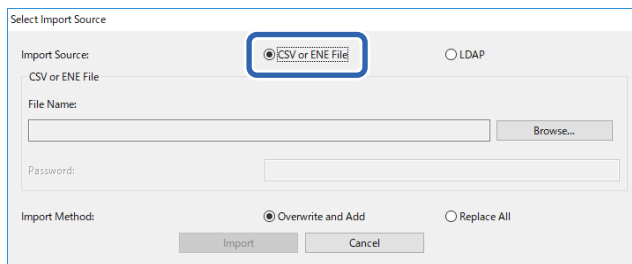
2. Click **Import**.3. Select **CSV or ENE File** for **Import Source**.4. Click **Browse**.

The file selection screen is displayed.

5. Select the file to import, and then click **Open**.

6. Select how to import the file.

- Overwrite and Add: If there is the same user ID, overwrite it, otherwise add it.
- Replace All: Replace the all user information to the new one.

7. Click **Import**.

The confirmation screen is displayed.

Information Registration and System Configuration

8. Click **OK**.

The validation result is displayed.

Check Results

No error was detected.
When you click "Import", the contents of the import file information list will be imported.

Error Information
No error was detected.

Detailed...

Imported Information

Valid Users: 10 / 1000

User ID	User name Display	Department
epson001	epson001	epson pubs
epson002	epson002	epson pubs
epson003	epson003	epson pubs
epson004	epson004	epson pubs
epson005	epson005	epson pubs
epson006	epson006	epson pubs
epson007	epson007	epson pubs
epson008	epson008	epson pubs
epson009	epson009	epson pubs
epson010	epson010	epson pubs

Edit

Delete Unnecessary Users...

Import Cancel

Note:

- When the user information exceeds the available number, an instruction to delete user information is displayed. Delete the user information that is exceeded before importing.
- When you click **Delete Unnecessary Users**, the user deletion screen is displayed. Select the user information and click **Delete**. You can delete the user information before importing.

9. Click **Import**.

The user information is imported to the configuration template.

Related Information

➔ [“Creating the CSV File” on page 35](#)

Importing from the LDAP Server

1. Select **Epson Open Platform Settings >Epson Print Admin Serverless Settings > User Settings**.
2. Click **Import**.
3. Select **LDAP** for **Import Source**.

Select Import Source

Import Source: CSV or ENE File **LDAP**

LDAP

LDAP Server Settings: Setting...

User Information is acquired from the following LDAP Server.

Server Address: Unset

Import Method: Overwrite and Add Replace All

Import Cancel

Information Registration and System Configuration

4. Click **Settings**.

LDAP server setting is displayed.

Note:

This LDAP server setting is the setting to import the user information from the LDAP server to the printer. The imported user information is used to authenticate users by the printer itself.

*On the other hand, when you select **LDAP** or **Local DB and LDAP** for the authentication method, communicate with the LDAP server to authenticate users.*

5. Set each item.

When importing user information from an LDAP server, you can make the following settings in addition to the items in the LDAP settings.

See related information for other items.

Items		Explanation
LDAP Server Settings	LDAP Server Type	Select the type of LDAP server.
Search Settings	Search Filter	Configure the search strings for the LDAP search filter. You can also edit the filters by selecting Custom .

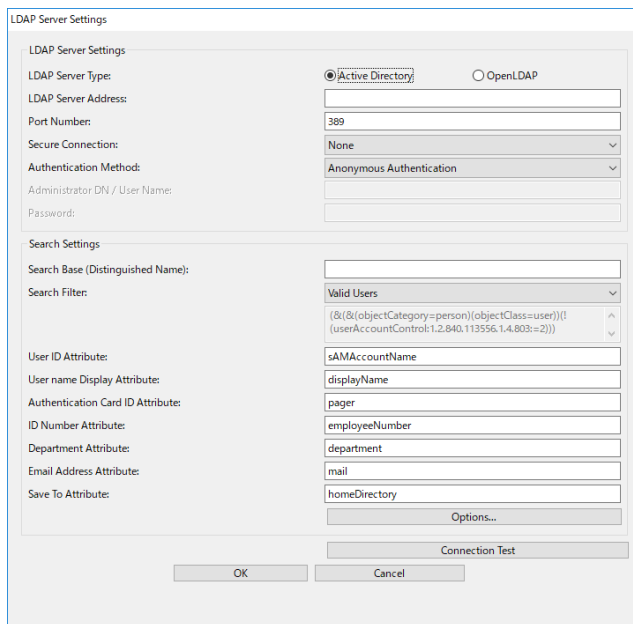

6. Perform the connection test as necessary by clicking **Connection Test**.

Display the 10 user information got from the LDAP server.

7. Click **OK**.

8. Select how to import the file.

- Overwrite and Add: If there is the same user ID, overwrite it, otherwise add it.
- Replace All: Replace the all user information to the new one.

9. Click **Import**.

The confirmation screen is displayed.

Information Registration and System Configuration

10. Click **OK**.

The validation result is displayed.

Note:

When you click **Delete Unnecessary Users**, the user deletion screen is displayed. Select the user information and click **Delete**. You can delete the user information before importing.

11. Click **Import**.

The user information is imported to the configuration template.

Related Information

- ➔ [“Creating the CSV File” on page 35](#)
- ➔ [“Synchronization with the LDAP Server \(Web Config\)” on page 37](#)
- ➔ [“User Maintenance” on page 68](#)
- ➔ [“LDAP Server Setting Items” on page 48](#)
- ➔ [“Search Setting Items” on page 50](#)

Other Functions Setting (Configuration Template)

Set the other functions as necessary.

Making Access Limitation Settings (Configuration Template)

Set the functions that are available to the registered user when logging in to Epson Print Admin Serverless.

Note:

When you use device authentication in Epson Print Admin Serverless, you can also set access restrictions for each user in *User Settings for Web Config*. See related information for details on the setting items.

1. Select **Administrator Settings > Access Limitation** from the configuration template.

Information Registration and System Configuration

2. Select **01**, and then click **Edit**.

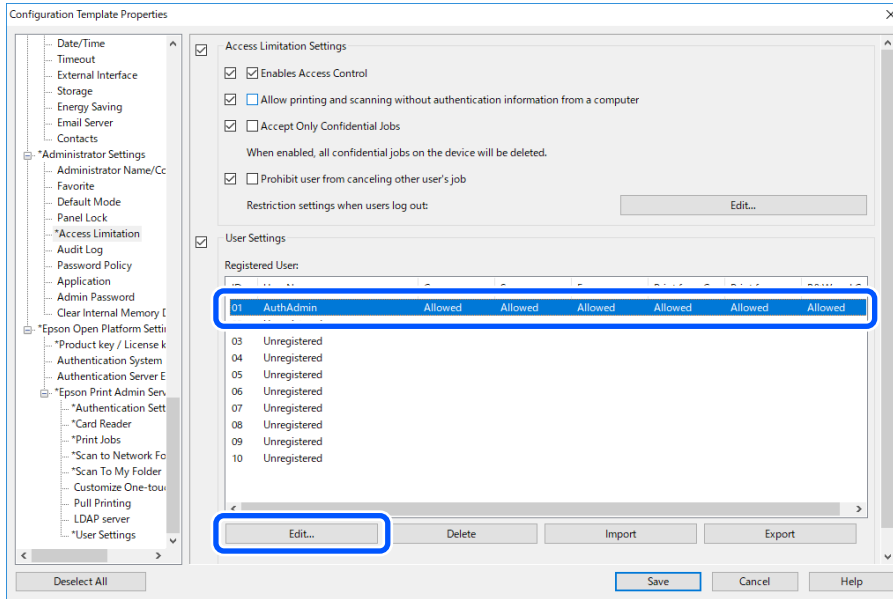

3. Select **Allowed** for the functions that you want to permit to use.

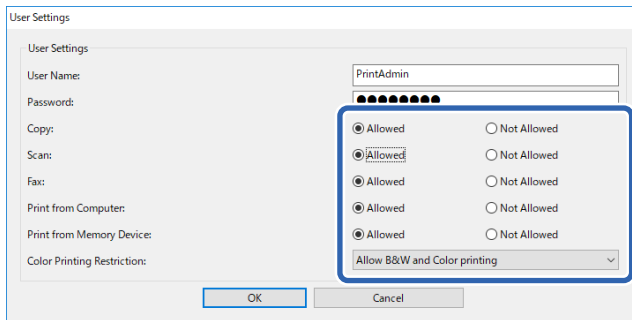

4. Click **OK**.

Related Information

- ➔ [“Making Available Function Settings \(Web Config\)”](#) on page 39
- ➔ [“User Information Setting Items”](#) on page 33

Allow printer to be used from drivers and software

Set permissions to allow users to print forms and so on from the computer.

Allow print jobs without authentication information (Configuration Template)

1. Select **Administrator Settings > Access Limitation** from the configuration template.

Information Registration and System Configuration

2. Select **Enables Access Control** and **Allow printing and scanning without authentication information from a computer** in **Access Limitation Settings**.

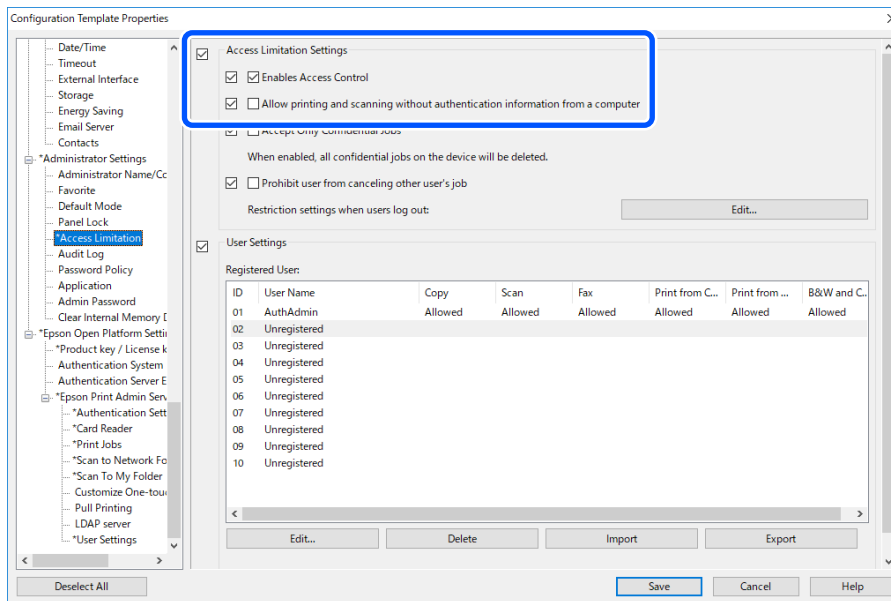

Client Computer Setting

Installation for the Printer Driver

Install the standard printer driver for your printer on the client computer. If it has already been installed, update it to the latest one.

Printer Driver Setting

To print as Epson Print Admin Serverless, it is necessary to send the user information to the printer together with the print job.

Register or set the user information to each client computer. When you set it, log in to the client computer using the administrator account.

For the settings or instructions on how to use it, see *Epson Print Admin Serverless How to Use > Printing from the Computer*.

User Settings for Windows Printer Driver

For Windows, set the user ID for the printer driver. There are three settings for the user information settings, which are explained below.

Set permanently

When you use authenticated printing from this computer, always use the user ID set in **User ID**. You do not need to set the user ID again when printing.

Select this setting when using the same user ID as the login name or when using a fixed user ID.

Set manually by each user

On the **More Options** tab in the printer driver, select **Settings** under **Job Type**, and then set the user ID in the **User ID Setting** window. Once you have set the user ID, you do not need to set it again unless you change the user ID that you want to use. To change the user ID, change the user ID in the **User ID Setting** window.

Prompt user at each print job

The **User ID Setting** window is displayed before printing, and then users can enter the user ID.

This setting is useful when multiple users use a computer with a single user account.

Print Methods

When printing from a computer, specify whether or not to print without storing print jobs. This function is available when it has been allowed in the print job settings.

Secure Print

Sent print jobs are stored on the printer. Log in to the printer using an authentication card and so on, and then print the job.

Client Computer Setting

❑ Direct Print

Sent print jobs are printed directly. Print jobs are not stored on the printer.

Epson Print Admin Serverless Settings

Use Epson Print Admin Serverless printing

Print Methods
Make sure this settings are in line with the device configuration.

Secure Print

Direct Print

User ID for authentication

Set permanently

User ID

Use Windows login name

Set User ID information

Set manually by each user
Set authentication information from the Settings button under Job Type.

Prompt user at each print job
When a print job is sent, the user is prompted to enter the user ID.

OK Cancel Help

Related Information

- ➔ [“Making Print Job Settings \(Web Config\)” on page 31](#)
- ➔ [“Making Print Job Settings \(Configuration Template\)” on page 46](#)

User Settings for Mac OS Printer Driver

For Mac OS, set the user ID for the printer driver when printing. You can skip entering your user ID by saving the information to your keychain.

Enter your user name and password.



Name: xxxxxx

Password:

Remember this password in my keychain

Cancel OK



Important:

For Mac OS, you cannot authenticate the printer's IP connection. Connect the printer using Bonjour or IPP protocol.

Related Information

- ➔ [“Connect the printer by using Bonjour” on page 60](#)

Client Computer Setting

➔ “Connect the printer by using IPP protocol” on page 60

Connect the printer by using Bonjour

1. Open **System Preferences > Printer and Scanner**.
2. Click **+**.
3. Make sure you select **Default**, and then select the printer you want to use from **Name**.
4. Select the printer you want to use from **Driver**, and then click **Add**.

Connect the printer by using IPP protocol

1. Open **System Preferences > Printer and Scanner**.
2. Click **+**.
3. Select **IP**.
4. Enter the printer's host name or IP address in **Address**.
5. Select **IPP (Internet Printing Protocol)** in **Protocol**.
6. Select the printer you want to use from **Driver**, and then click **Add**.

Connection Format for Authentication Information

When printing jobs from the printer driver, authentication information is required for USB connections and network connections. Print jobs without authentication information are discarded.

You can disable USB connections in the following way. In this situation, the print job is discarded.

Web Config:

Set **PC connection via USB** in **Product Security > External Interface** to **Disable**.

Epson Device Admin (Configuration Templates):

Set **USB Device Interface** in **Common > External Interface** to **Do Not Use**.

Operation and Management

Setting an Administrator Password and Administrator Lock

You can use an administrator password and administrator lock to protect against the printer's user changing the system settings.

On Web Config and Epson Device Admin, when you set an administrator password, the printer is locked with an administrator lock. On the printer's control panel, set an administrator password, and then enable the administrator lock.

See the manual for details on the settings.

User Reports Using Epson Device Admin

You can create an Epson Print Admin Serverless report for each group and each user by using Epson Device Admin. You can create the report by specifying a period or setting a regular schedule. Create device groups before creating reports.

These settings are displayed when you enable the Epson Print Admin Serverless Settings menu.



Important:

*When you have set an administrator password for the printer, set the same password by selecting **Options > Password manager**.*

You cannot acquire job histories from the printer if the password is not set.

Related Information

➔ [“Displaying Epson Print Admin Serverless Settings menu” on page 67](#)

Creating User Reports

1. Select **Reports** on the side bar task menu.
2. Select **User Defined Report > Scheduled Reports** from the tree view.

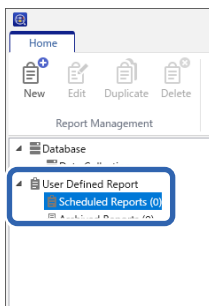

Operation and Management

- Click **New** on the ribbon menu.

The report creation Wizard is displayed.



- Select the condition when acquiring report data from the following items.

Usage Per User / Usage Per Department / Job History

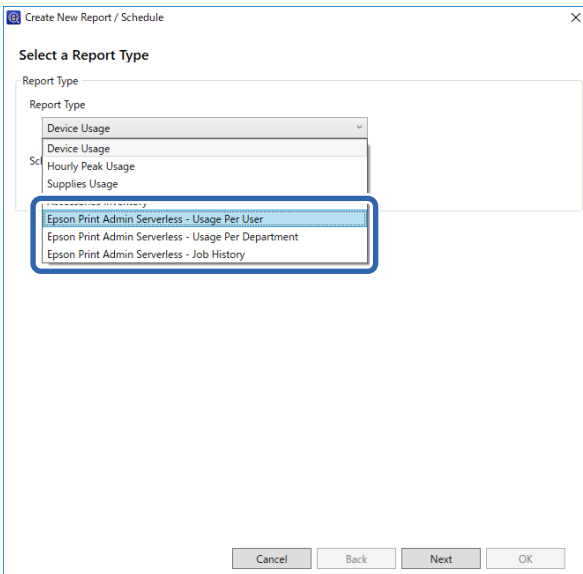

- Select the conditions used to create a report by specifying the period or setting a schedule.

Create report by specifying a period: Clear the **Create a Schedule** check box.

Create report by setting the schedule: Select the **Create a Schedule** check box.

- Click **Next**.

- Select the target device group.

Target groups are listed in the box on the right. To change these, move groups by using >, >>, <, and <<.

You can move selected groups by using >, <, and all groups by using >>, <<.

Select **Include child group(s)** to automatically select child groups within the selected group.

Operation and Management

Note:

If you print a job without storing it in the printer, a report for Usage Per Department is not created.

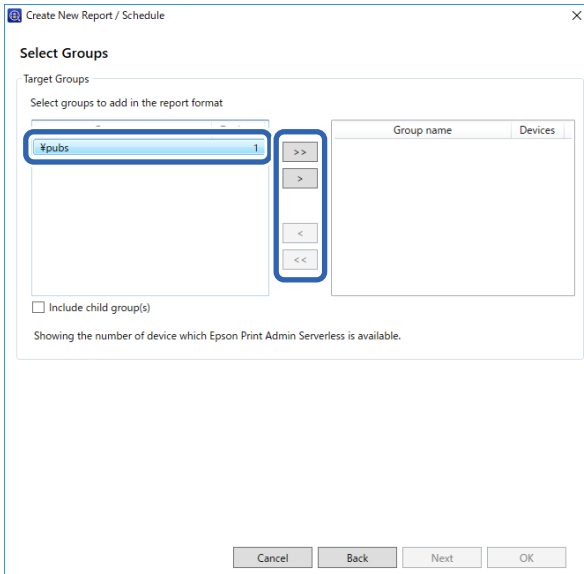

8. Click **Next**.

9. Specify the report range.

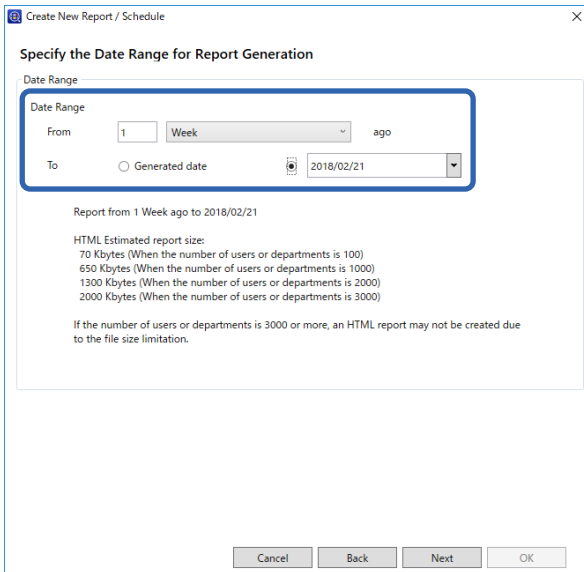

See the following to make the settings.

Item	Explanation
Date Range	Specify the report range from the date the report was created or by specifying a date on the calendar. Specify by using a combination of any number over 1 and a day/week/month/year.

10. Click **Next**.

Operation and Management

11. Specify email destinations.

See the following to make the settings.

Item	Explanation
Type	Specify whether or not to send a notification email.
To	Enter the address to which the alerts are sent. When entering multiple addresses, separate the addresses with semi-colons (;). You can enter up to 32,767 bytes including [;]. Enter all addresses in the [TO] field. You cannot use the [CC] or [BCC] fields.
Subject	The subject of the alert notification email. You can enter up to 256 characters.
File format	Sets the file format. You can select from PDF, HTML, or CSV. You can select only CSV when Job History is selected in step 4.

12. Click **Next**.

Operation and Management

13. Specify a report name.

Enter up to 1024 characters in Unicode.

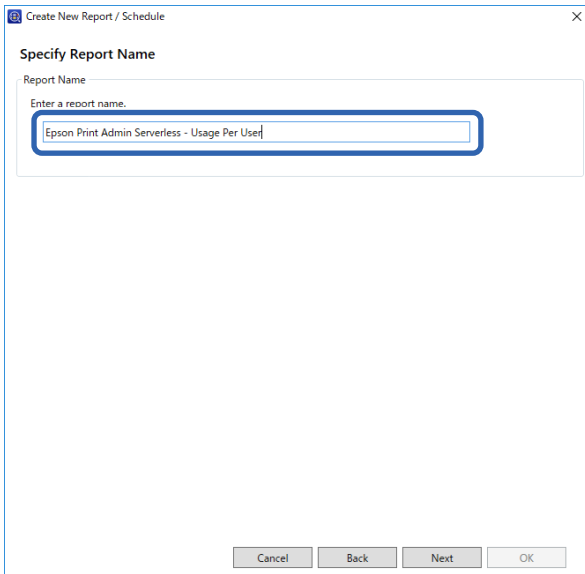

14. Click **Next**.

15. Specify a schedule.

Note:

- If you clear the **Create a Schedule** check box in step 5, this screen is not displayed.
- Set the **Start date and time** for the **Creation Schedule** after the data collection time. If this is set to before the data collection time, the report is created before starting data collection on the last day in the report range.

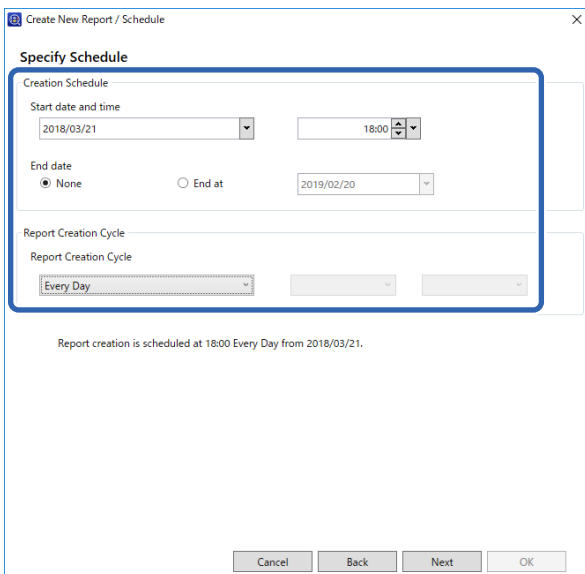

See the following to make the settings.

Item	Explanation
Start date and time	Set the day to start the schedule. The units are intervals of one minute.

Operation and Management

Item	Explanation
End date	Set the day to end the schedule. Select None if you do not want to specify an end day.
Report Creation Cycle	Specify the interval for creating reports.

16. Click **Next**.

17. Click **OK**.

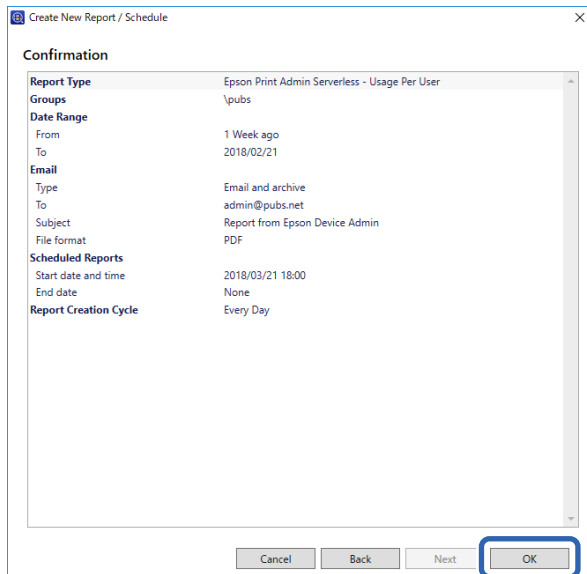

The report or schedule is created. The created report is saved as an archive report.

Report Output Items

The following items are output in the report.

Usage Per User

Date/Job ID/Operation/User ID/Department/Result/Result details/Job Name/Print: User Name/Print: Paper Size/Print: 2-Sided/Print: Color/Print: Pages/Scan: Destination type/Scan: Destination/Scan: Paper Size/Scan: 2-Sided/Scan: Color/Scan: Pages/Copy: Paper Size/Copy: 2-Sided/Copy: Color/Copy: Pages/Fax receiving: Paper Size/Fax receiving: 2-Sided/Fax receiving: Color/Fax receiving: Pages/Devices: Model/Devices: IP Address/Devices: Serial Number/Devices: Department/Devices: Location/Devices: Remark/Devices: Note

Usage Per Department

Department/Subtotal pages/PrintColor1-Sided/PrintColor2-Sided/PrintBlack and White1-Sided/PrintBlack and White2-Sided/CopyColor1-Sided/CopyColor2-Sided/CopyBlack and White1-Sided/CopyBlack and White2-Sided/Fax transmission/Scan/Fax receiving

Note:

If you print a job without storing it in the printer, a report for Usage Per Department is not created.

Job History

User ID/Department/Subtotal pages/PrintColor1-Sided/PrintColor2-Sided/PrintBlack and White1-Sided/PrintBlack and White2-Sided/CopyColor1-Sided/CopyColor2-Sided/CopyBlack and White1-Sided/CopyBlack and White2-Sided/Fax transmission/Scan/Fax receiving

Managing Printers by Using Epson Device Admin

You can manage the printers by using Epson Device Admin.

Displaying Epson Print Admin Serverless Settings menu

Display the settings menu related to Epson Print Admin Serverless. They are set not to be displayed by default.



Important:

When the administrator password is set to the printer, configure the password in advance.

1. Display the device list, and then select **Options** > **Password manager**.
2. Select **Enable automatic password management**, and then click **Password manager**.
3. Select the printer that you set the password to, and then click **Edit**.
4. Set the password, and then click **OK**.

1. Start Epson Device Admin.
2. Click **Options** on the ribbon menu, and then select **Epson Print Admin Serverless Settings**.

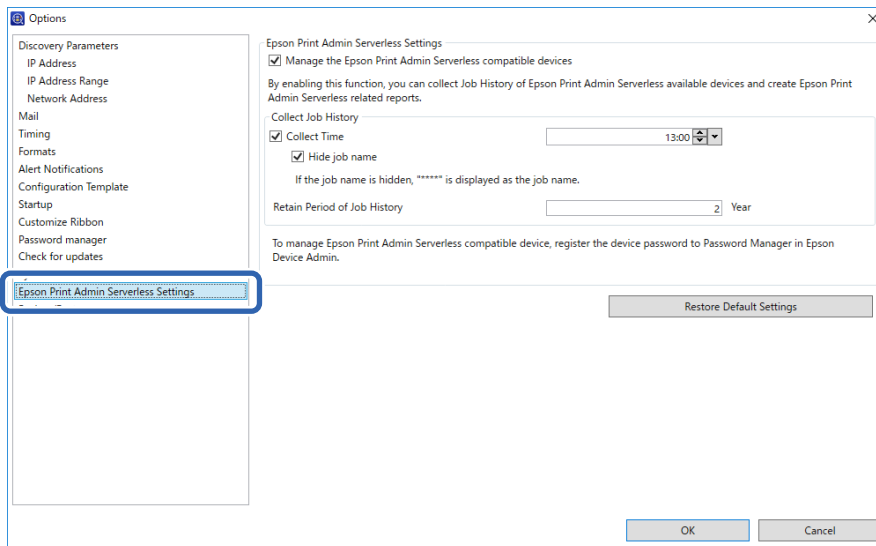

3. Set each item.
4. Click **OK**.

Operation and Management

Epson Print Admin Serverless Settings

Item	Explanation
Manage the Epson Print Admin Serverless compatible devices	Select to enable settings for Epson Print Admin Serverless and perform the following operations and settings. <ul style="list-style-type: none"> <input type="checkbox"/> Collect job history data for Epson Print Admin Serverless compatible printers <input type="checkbox"/> Create Epson Print Admin Serverless related reports <input type="checkbox"/> Display the Edit Device Users button on the ribbon menu
Collect Time	Select to set the collection time for the job history data of the Epson Print Admin Serverless compatible printers.
Hide job name	Select to hide the print job names recorded in the job history. Select when you do not want to display the print job names.
Retain Period of Job History	You can set the period to save the job history on Epson Device Admin up to five years. The expired job history is deleted.

User Maintenance

You can maintain the user information registered on the printer.

Editing Individually

- Select the printer whose user information you want to edit from the device list.

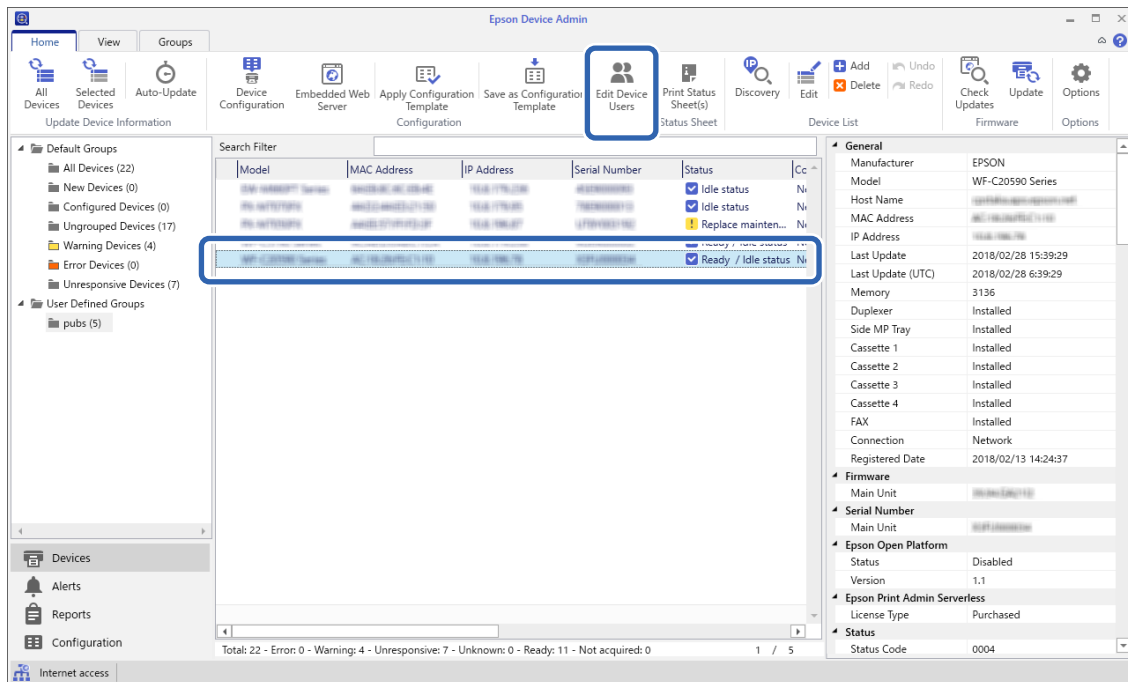

- Select **Configuration - Edit Device Users** from the ribbon menu.

The user list is displayed.

Operation and Management

3. Select the user you want to edit.

Note:

You can search the user list by selecting the item you want to find from **Find**, entering the keyword, and clicking **Execute**.

Click **Clear** to clear the value you entered.

4. Click **Edit**.

The user information is displayed.

5. Edit each item, and then click **OK**.

The 'Edit User' dialog box contains the following fields:

- User ID:
- User name Display:
- Password:
- Authentication Card ID:
- ID Number: Generate automatically in the device
- Department:
- Mail Address:

Buttons: (highlighted),

6. Click **Transmit**.

The send confirmation screen is displayed.

The 'Epson Device Admin' window shows the following details:

- User Settings: Find:
- Number of Entries:
- User List:

Nu...	User ID	User name Display	Department	E-Mail Address
0001	epson001	epson001	epson pubs	epson001@pubs.net
0002	epson002	epson002	epson pubs	epson002@pubs.net
0003	epson003	epson003	epson pubs	epson003@pubs.net
0004	epson004	epson004	epson pubs	epson004@pubs.net
0005	epson005	epson005	epson pubs	epson005@pubs.net
0006	epson006	epson006	epson pubs	epson006@pubs.net
0007	epson007	epson007	epson pubs	epson007@pubs.net
0008	epson008	epson008	epson pubs	epson008@pubs.net
0009	epson009	epson009	epson pubs	epson009@pubs.net
0010	epson010	epson010	epson pubs	epson010@pubs.net
0011				
0012				
0013				
0014				
0015				
0016				
0017				
0018				

Buttons: , , , , (highlighted), ,

7. Click **OK** on the send confirmation screen.

8. Click **OK** on the completion screen.

Editing in Bulk

1. Select the printer whose user information you want to edit from the device list.

Operation and Management

2. Select **Configuration > Edit Device Users** from the ribbon menu.

The user list is displayed.

3. Click **Export**.

The screen to select an export method is displayed.

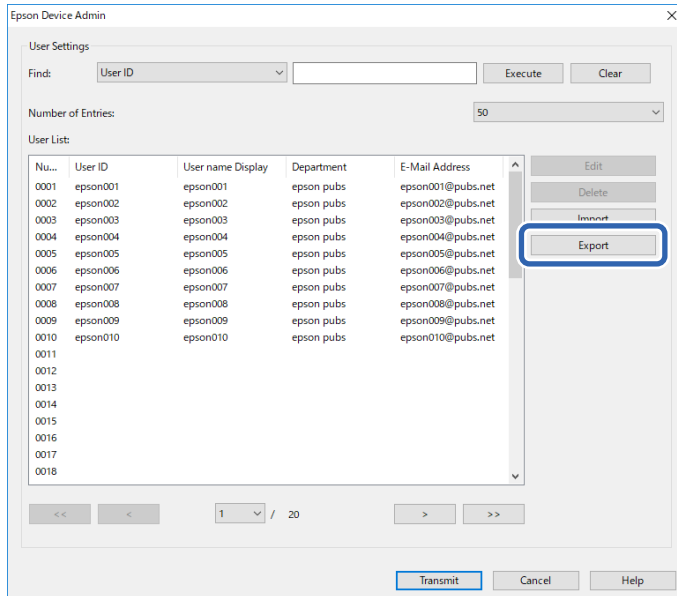

4. Select an export method for the user information.

Select **CSV File UTF-16 (*.csv)** when editing the CSV file using Microsoft Excel. See the next section for more information on the file format.

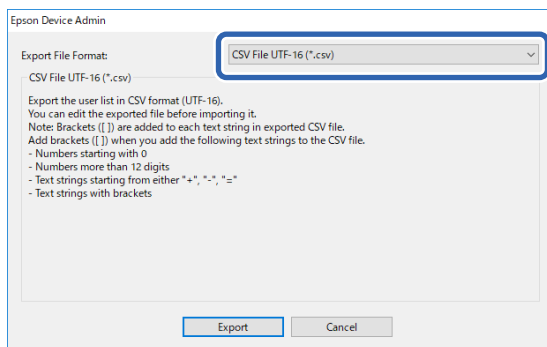

5. Click **Export**.

6. Select the location where you want to save the file, and then click **Save**.

The file is saved.

7. Edit and save this CSV file in a spreadsheet application such as Microsoft Excel or in a text editor.



Important:

Do not change the encoding or header information of the file. You may not be able to import the file.

8. Click **Import**.

Operation and Management

9. Select **CSV or ENE File** on **Import Source**.

10. Click **Browse**.

The file selection screen is displayed.

11. Select the file you want to import, and then click **Open**.

12. Select an import method.

- Overwrite and Add** : If there is the same user ID, overwrite it. Otherwise add it.
- Replace All** : Replace all the user information with the new one.

13. Click **OK**.

The confirmation screen is displayed.

14. Click **OK**.

Verification of the imported file starts, and the result is displayed.

Note:

Click **Valid Users** to open the user information deletion screen. You can delete the user information before importing by selecting it and clicking **Delete**.

15. Click **Import**.

Export Format

Item	Explanation
CSV File UTF-16 (*.csv)	Export to a tab-delimited CSV file encoded in Unicode (UTF-16).
CSV File UTF-8 (*.csv)	Export to a comma-delimited or semicolon-delimited CSV file encoded in Unicode (UTF-8). The delimiter can be set in CSV data delimiter by selecting Options > Formats .
Binary file (*.ene)	Export to an ENE file. You can set the password to it for import. You cannot edit the ENE file since it is an encrypted binary file.

Checking the Printer Information from Web Config

You can check the printer information by using Web Config.

Email Notifications and Snapshots

You can check the status of the remote printer by using email notifications and panel snapshots.

About Email Notifications

This is the notification function that, when events such as printing stop and printer error occur, send the email to the specified address.

You can register up to five destinations and set the notification settings for each destination.

To use this function, you need to set up the mail server before setting up notifications.

See the manual for details on the settings.

The screenshot shows the Epson Web Config interface for the 'Email Notification' settings. The page is titled 'Email Notification' and includes a navigation menu on the left with options like 'Email Notification', 'Control Panel', 'Power Saving', 'Card Reader', 'Stored Data', 'Export and Import Setting Value', 'Firmware Update', 'Administrator Name/Contact Information', 'Date and Time', and 'Clear Internal Memory Data'. The main content area is divided into three sections: 'Subject Setting', 'Email Address Settings', and 'Notification Settings'. The 'Subject Setting' section has a text input field for the subject line, with a dropdown menu for 'Printer Model'. The 'Email Address Settings' section has five rows for 'Address 1' through 'Address 5', each with a text input field and a language dropdown menu set to 'English'. The 'Notification Settings' section has a table with columns for 'Address' (1-5) and rows for 'Replacing toner cartridge is required', 'Toner low', 'Replacing waste toner collector is required', and 'Waste toner collector is nearing end'. Each cell in the table contains a checkbox. At the bottom of the page, there are 'OK' and 'Restore Default Settings' buttons.

Checking the Panel Display of the Remote Printer

You can check the panel display of the remote printer by using Web Config.

1. Run Web Config of the printer that you want to check.
When you receive the email notification, you can run Web Config from the URL on the email.
2. Select **Status** tab > **Panel Snapshot**.
The current panel of the printer is displayed on Web Config.

Operation and Management

To update, click **Refresh**.

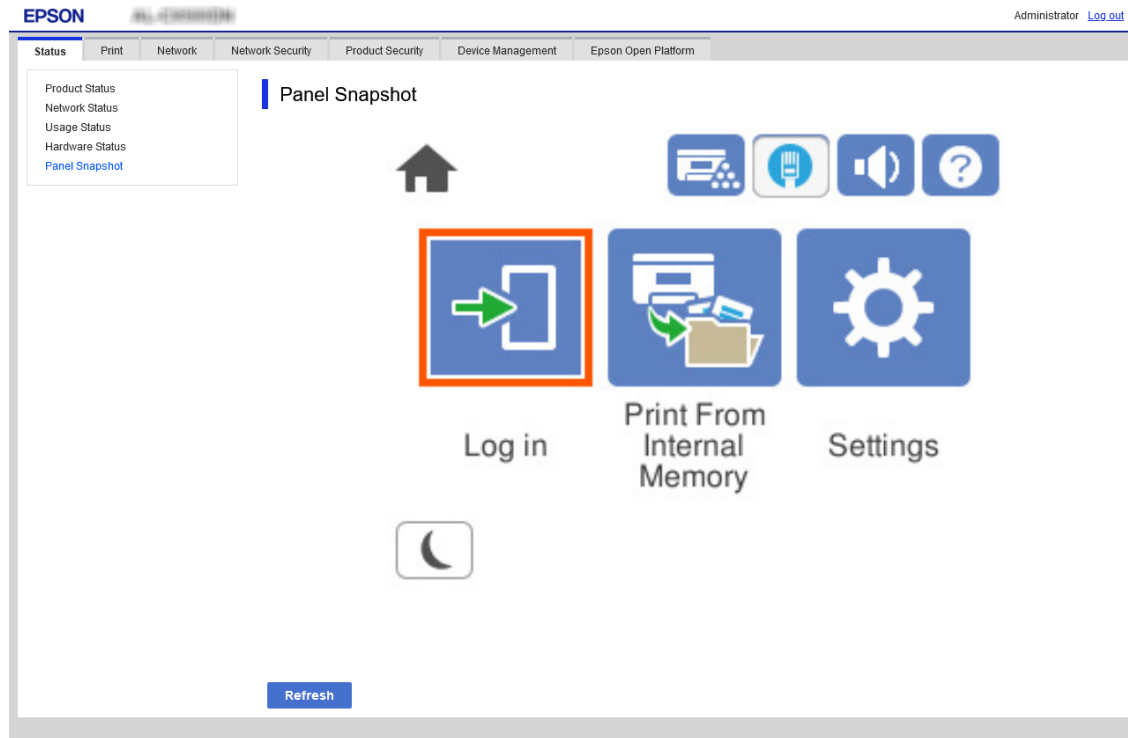

Related Information

➔ [“Accessing Web Config” on page 10](#)

Deleting the Print Jobs

You can delete the print jobs stored in the printer.

1. Access Web Config, and then select the **Epson Open Platform** tab > **Epson Print Admin Serverless** > **Print Jobs**.

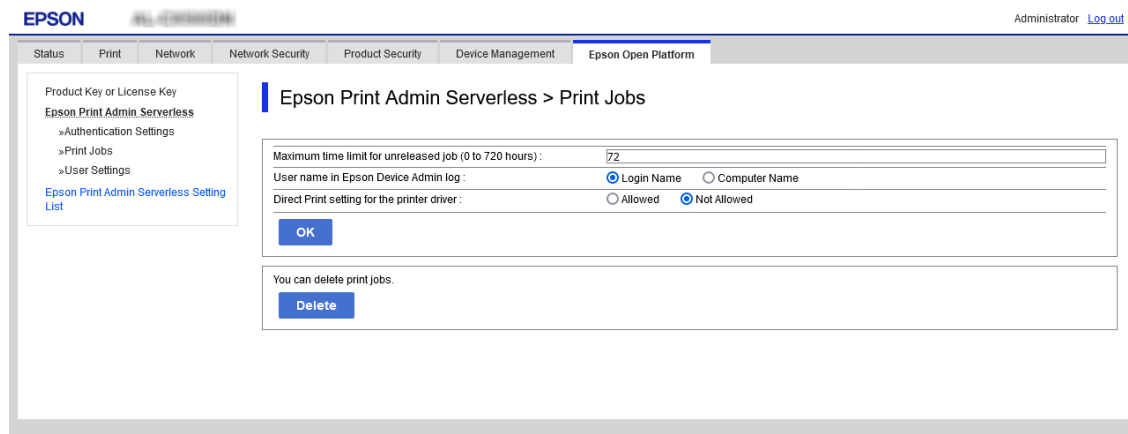

2. Click **Delete**.

Related Information

➔ “Accessing Web Config” on page 10

Backing Up the Settings

You can back up the settings on Web Config and the configuration templates on Epson Device Admin.

Important:

- You cannot back up the license key. We recommend writing it down in a text file or as a note.
When you replace the printer, you cannot use the same license key. In this case, ask your dealer.
- To back up Epson Print Admin Serverless settings, make sure that the license key is set before exporting.

Settings in Web Config

You can export the setting value set from Web Config to the file. You can use it for backing up the contacts, setting values, replacing the printer, etc. The exported file cannot be edited because it is exported as a binary file.

Export the settings

Export the setting for the printer.

1. Access Web Config, and then select the **Device Management** tab > **Export and Import Setting Value** > **Export**.
2. Select the settings that you want to export.

Select the settings you want to export. If you select the parent category, subcategories are also selected. However, subcategories that cause errors by duplicating within the same network (such as IP addresses and so on) cannot be selected.

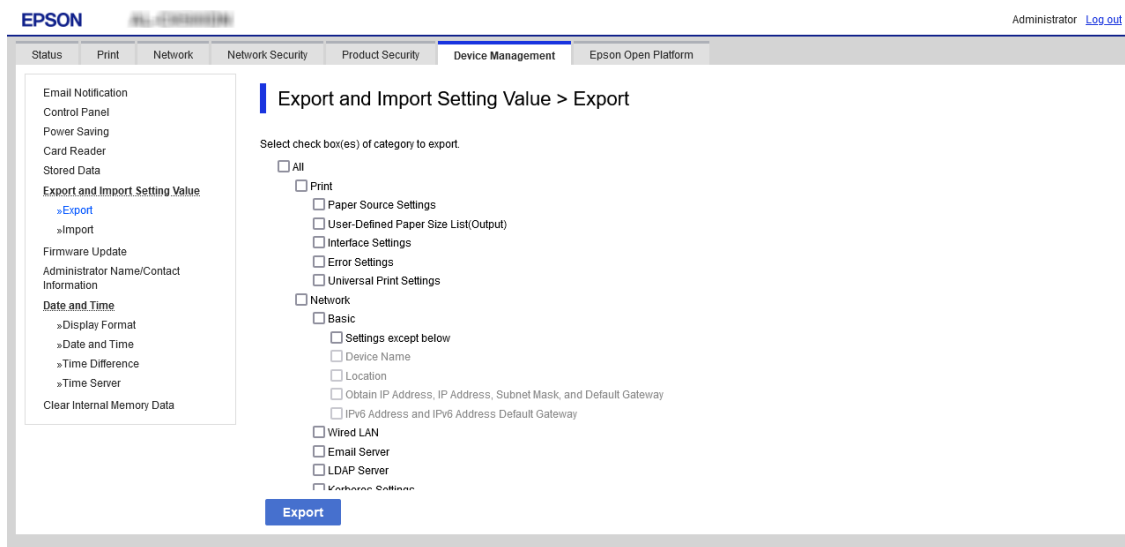

Operation and Management

3. Enter a password to encrypt the exported file.

You need the password to import the file. Do not enter any characters if you do not want to encrypt the file.

4. Click **Export**.



Important:

*If you want to export the printer's network settings such as the device name and IPv6 address, select **Enable to select the individual settings of device** and select more items. Only use the selected values for the replacement printer.*

Related Information

➔ [“Accessing Web Config” on page 10](#)

Import the settings

Import the exported Web Config file to the printer.



Important:

- The exported Web Config file does not contain the license key. If Epson Print Admin Serverless is disabled, select the **Epson Open Platform** tab > **Product Key or License Key**, and then enter the license key before importing to enable Epson Print Admin Serverless.*
- When importing values that include individual information such as a printer name or IP address, make sure the same IP address does not exist on the same network. If the IP address overlaps, the printer does not reflect the value.*

1. Access Web Config, and then select the **Epson Open Platform** tab > **Product Key or License Key**, and then enter the license key in **Product Key or License Key**.
2. Select the **Device Management** tab > **Export and Import Setting Value** > **Import**.
3. Select the exported file, and then enter the encrypted password.
4. Click **Next**.
5. Select the settings that you want to import, and then click **Next**.
6. Click **OK**.

The settings are applied to the printer.

Related Information

➔ [“Accessing Web Config” on page 10](#)

Configuration Templates in Epson Device Admin

You can save and restore configuration templates to a file.

See the Epson Device Admin manuals for information about backing up your device list, printer info, etc..

Backing Up Configuration Templates

1. Select **Configuration** on the side bar task menu.
2. Select a configuration template to backup from the template list.

You cannot select preset configuration templates.

Note:

To make multiple selections, press *Ctrl* or *Shift* and click your mouse.

3. Click **Backup** on the ribbon menu.

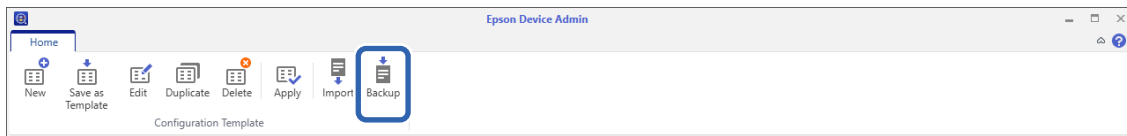

4. Select the destination to save the file and enter a file name.

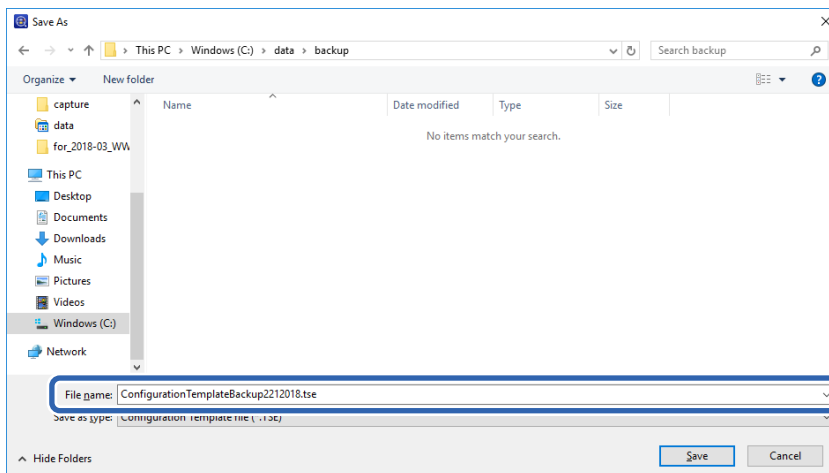

5. Click **Save**.
TSE format template files are saved together in a Zip file.

Importing Configuration Templates

Unzip the Zip file containing configuration templates and retrieve the configuration template files (TSE format).

1. Select **Configuration** on the side bar task menu.
2. Click **Import** on the ribbon menu.
The file import screen is displayed.



Operation and Management

3. Select the configuration template file (TSE format) to be imported.
4. Click **Open**.
The configuration template is imported and the results are displayed.
5. Click **OK**.

Disabling Epson Print Admin Serverless

Disable the Epson Print Admin Serverless setting.



Important:

When you re-enable Epson Print Admin Serverless after disabling, the setting values are restored to their defaults. We recommend that you back up the settings before disabling."

Related Information

➔ [“Backing Up the Settings” on page 74](#)

Disabling from Web Config

You can disable the Epson Print Admin Serverless license by using Web Config.

1. Access Web Config, and then select the **Epson Open Platform** tab > **Product Key or License Key**.
2. Delete the product key in **Product Key or License Key**.

The screenshot shows the Epson Web Config interface. At the top, there is a navigation bar with tabs: Status, Print, Network, Network Security, Product Security, Device Management, and Epson Open Platform. The 'Epson Open Platform' tab is selected. Below the navigation bar, there is a sidebar menu with options: Product Key or License Key, Epson Print Admin Serverless, Authentication Settings, Print Jobs, User Settings, and Epson Print Admin Serverless Setting List. The main content area is titled 'Product Key or License Key' and contains the following text: 'Set the product key or license key to add functions to the product. Enter the product key including the hyphens in the alphanumeric characters.' Below this text, there are two input fields: 'Serial Number' (with a placeholder 'XXXXXXXXXX') and 'Product Key or License Key'. The 'Product Key or License Key' field is highlighted with a blue box. Below the input fields, there is a section for 'License information (Epson Print Admin Serverless)' with two rows: 'Type' (Purchased) and 'Days remaining' (Perpetual). At the bottom of the page, there is a blue 'Next' button.

3. Click **Next**.
The settings are displayed.
4. Click **OK**.
The settings are transmitted to the printer and the communication is interrupted. After a moment, reload the page for Web Config.

Operation and Management

5. Select the **Epson Open Platform** tab > **Product Key or License Key**.

When **License Information (Epson Print Admin Serverless)** is displayed under the **Epson Open Platform Settings** hierarchy, Epson Print Admin Serverless is activated.

Note:

- ❑ *All print jobs stored in the printer are deleted. User information and logs are retained even if Epson Print Admin Serverless is disabled. They can be deleted when the printer settings are restored to their defaults.*

- ❑ *For Windows, set the following on the printer driver.*

*Select **Control Panel** > **Devices and Printers**, right-click the printer icon, and then select **Printer properties**.*

*Select the **Optional Settings** tab.*

*Click **Get in Acquire from Printer** on **Printer Information**.*

*Confirm that **Epson Print Admin Serverless** is changed to **Disable**.*

Related Information

- ➔ [“Accessing Web Config” on page 10](#)

Solving Problems

Cannot Read the Authentication Card

Check the following.

- Check if the authentication device is connected to the printer correctly.
Make sure you connect the authentication device to the service port of the printer.
- Check that the authentication device and the authentication card are certified.
Contact your dealer for information on supported authentication devices and cards.

Cannot Open Web Config

Check the following.

- Check that the IP address entered for the printer is correct.
You can check the IP address from the control panel, by running a network diagnosis, and from the status sheet. See the manual supplied with the printer for more details.
- Perform network diagnosis to check that the printer is connected to the network.
See the manual supplied with the printer for more details.

Cannot Activate Epson Print Admin Serverless

Make sure you entered the correct license key in Web Config or Epson Device Admin.

The Message that Indicates the License Key Has Expired Is Displayed

When the message that indicates the license key has expired is displayed during the validity period, check that the printer's date and time settings are correct.

Ask your dealer for the validity period of the license.

Epson Device Admin Report Has No Content

When there is no content in the report for Usage Per User, Usage Per Department, and Job History in Epson Device Admin, check the following.

- When you set the administrator password to the printer
Check that you set the password by selecting **Options > Password manager**.
You cannot collect job histories from the printer if the password is not set.

Solving Problems

- ❑ When you changed the administrator password using the printer
Check that you changed the set password by selecting **Options > Password manager**.
- ❑ Check that the Epson Print Admin Serverless license key was recognized in Epson Device Admin.
Check the license status by the following method.
 1. Run Epson Device Admin, and then select a target printer on the device list.
 2. Check the text displayed in **License Type** of **Epson Print Admin Serverless** on the detailed device information pane.If license key is not recognized despite that you set it, acquire device information by clicking **All Devices** or **Selected Devices** on ribbon menu.
- ❑ If you print a job without storing it in the printer, a report for Usage Per Department is not created.

Appendix

Functions that Enhance Printer Security

Epson printers have a variety of security technologies. Set the printer as necessary according to the environmental conditions that have been built with the customer's environment information. See the manual for details on the settings.

Name	Feature type	What to set	What to prevent
SSL/TLS communications	The communication content is encrypted with SSL/TLS communications when accessing to the Epson server on the Internet from the printer, such as communicating to the computer via web browser, using Epson Connect, and updating firmware.	Obtain a CA-signed certificate, and then import it to the printer.	Clearing an identification of the printer by the CA-signed certification prevents impersonation and unauthorized access. In addition, communication contents of SSL/TLS are protected, and it prevents the leakage of contents for printing data and setup information.
Control of protocol	Controls the protocols and services to be used for communication between printers and computers, and it enables and disables features.	A protocol or service that is applied to features allowed or prohibited separately.	Reducing security risks that may occur through unintended use by preventing users from using unnecessary functions.
IPsec/IP filtering	You can set to allow severing and cutting off of data that is from a certain client or is a particular type. Since IPsec protects the data by IP packet unit (encryption and authentication), you can safely communicate unsecured protocol.	Create a basic policy and individual policy to set the client or type of data that can access the printer.	Protect unauthorized access, and tampering and interception of communication data to the printer.
IEEE802.1X	Allows only a user who is authenticated to Wi-Fi and Ethernet to connect. Allows only a permitted user to use the printer.	Authentication setting to the RADIUS server (authentication sever).	Protect unauthorized access and use to the printer.

Note:

WSD printing is enabled by default. We recommend disabling WSD printing when performing authenticated printing.

You can disable WSD by managing the protocols. See the manual for details on the settings.

User Information Recorded in the Printer

The user information recorded in the printer and the method to delete it are as follows.

Appendix

Information	Deleting method	Storage
Epson Print Admin Serverless User Settings <input type="checkbox"/> User ID <input type="checkbox"/> User name Display <input type="checkbox"/> Password <input type="checkbox"/> Authentication Card ID <input type="checkbox"/> Department	Printer's control panel > General Settings > System Administration > Restore Default Settings > All settings	Data storage: Flash memory
	Web Config > Epson Open Platform tab > Epson Print Admin Serverless > User Settings > Delete All or Delete	
	Web Config > Epson Open Platform tab > Product Key or License Key Enter the product key for Epson Open Platform.	
Epson Print Admin Serverless Logs	Printer's control panel > General Settings > System Administration > Restore Default Settings > All settings	Data storage: <input type="checkbox"/> Flash memory <input type="checkbox"/> Hard disk
Epson Print Admin Serverless Stored print jobs	Printer's control panel > General Settings > System Administration > Restore Default Settings > All settings	Data storage: Hard disk
	Printer's control panel > General Settings > System Administration > HDD Erase Settings > Erase All Memory	
	Printer's control panel > General Settings > System Administration > Security Settings > Delete All Internal Memory Jobs	
	Web Config > Epson Open Platform tab > Epson Print Admin Serverless > Print Jobs > Delete All Print Jobs or Delete All	

Trademarks

- EPSON® is a registered trademark, and EPSON EXCEED YOUR VISION or EXCEED YOUR VISION is a trademark of Seiko Epson Corporation.
- Chrome, Chrome OS, and Android are trademarks of Google Inc.
- Microsoft®, Windows®, Windows Server®, and Windows Vista® are registered trademarks of Microsoft Corporation.
- Apple, macOS, OS X, Bonjour, and Safari are trademarks of Apple Inc., registered in the U.S. and other countries.
- General Notice: Other product names used herein are for identification purposes only and may be trademarks of their respective owners. Epson disclaims any and all rights in those marks.

© 2021 Seiko Epson Corporation.

Free Manuals Download Website

<http://myh66.com>

<http://usermanuals.us>

<http://www.somanuals.com>

<http://www.4manuals.cc>

<http://www.manual-lib.com>

<http://www.404manual.com>

<http://www.luxmanual.com>

<http://aubethermostatmanual.com>

Golf course search by state

<http://golfingnear.com>

Email search by domain

<http://emailbydomain.com>

Auto manuals search

<http://auto.somanuals.com>

TV manuals search

<http://tv.somanuals.com>