

SERVICE MANUAL

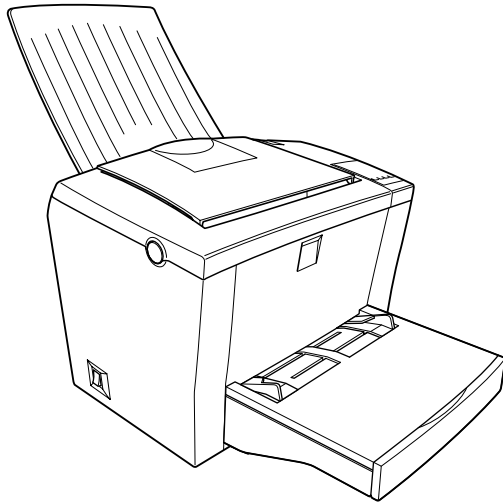

A4 Monochrome Laser Printer

EPSON EPL-5800



EPSON®

SEPG99012

Notice

- All rights reserved. No part of this manual may be reproduced, stored in a retrieval system, or transmitted in any form or by any means, electronic, mechanical, photocopying, recording, or otherwise, without the prior written permission of SEIKO EPSON CORPORATION.
- The contents of this manual are subject to change without notice.
- All efforts have been made to ensure the accuracy of the contents of this manual. However, should any errors be detected, SEIKO EPSON would greatly appreciate being informed of them.
- The above notwithstanding SEIKO EPSON CORPORATION can assume no responsibility for any errors in this manual or the consequences thereof.

EPSON is a registered trademark of SEIKO EPSON CORPORATION.

General Notice: Other product names used herein are for identification purpose only and may be trademarks or registered trademarks of their respective owners. EPSON disclaims any and all rights in those marks.

Copyright © 1999 SEIKO EPSON CORPORATION. Printed in Japan.

PRECAUTIONS

Precautionary notations throughout the text are categorized relative to 1) Personal injury and 2) Damage to equipment.



Signals a precaution which, if ignored, could result in serious or fatal personal injury. Great caution should be exercised in performing procedures preceded by a WARNING heading.



Signals a precaution which, if ignored, could result in damage to equipment.

The precautionary measures itemized below should always be observed when performing repair/maintenance procedures.

DANGER

1. ALWAYS DISCONNECT THE PRODUCT FROM THE POWER SOURCE AND PERIPHERAL DEVICES PERFORMING ANY MAINTENANCE OR REPAIR PROCEDURES.
2. NOWORK SHOULD BE PERFORMED ON THE UNIT BY PERSONS UNFAMILIAR WITH BASIC SAFETY MEASURES AS DICTATED FOR ALL ELECTRONICS TECHNICIANS IN THEIR LINE OF WORK.
3. WHEN PERFORMING TESTING AS DICTATED WITHIN THIS MANUAL, DO NOT CONNECT THE UNIT TO A POWER SOURCE UNTIL INSTRUCTED TO DO SO. WHEN THE POWER SUPPLY CABLE MUST BE CONNECTED, USE EXTREME CAUTION IN WORKING ON POWER SUPPLY AND OTHER ELECTRONIC COMPONENTS.

WARNING

1. REPAIRS ON EPSON PRODUCT SHOULD BE PERFORMED ONLY BY AN EPSON CERTIFIED REPAIR TECHNICIAN.
2. MAKE CERTAIN THAT THE SOURCE VOLTAGES IS THE SAME AS THE RATED VOLTAGE, LISTED ON THE SERIAL NUMBER/RATING PLATE. IF THE EPSON PRODUCT HAS A PRIMARY AC RATING DIFFERENT FROM AVAILABLE POWER SOURCE, DO NOT CONNECT IT TO THE POWER SOURCE.
3. ALWAYS VERIFY THAT THE EPSON PRODUCT HAS BEEN DISCONNECTED FROM THE POWER SOURCE BEFORE REMOVING OR REPLACING PRINTED CIRCUIT BOARDS AND/OR INDIVIDUAL CHIPS.
4. IN ORDER TO PROTECT SENSITIVE MICROPROCESSORS AND CIRCUITRY, USE STATIC DISCHARGE EQUIPMENT, SUCH AS ANTI-STATIC WRIST STRAPS, WHEN ACCESSING INTERNAL COMPONENTS.
5. REPLACE MALFUNCTIONING COMPONENTS ONLY WITH THOSE COMPONENTS BY THE MANUFACTURE; INTRODUCTION OF SECOND-SOURCE ICs OR OTHER NONAPPROVED COMPONENTS MAY DAMAGE THE PRODUCT AND VOID ANY APPLICABLE EPSON WARRANTY.

PREFACE

This manual describes basic functions, theory of electrical and mechanical operations, maintenance and repair procedures of EPL-5800. The instructions and procedures included herein are intended for the experienced repair technicians, and close attention should be given to the precautions on the preceding page. Chapters are organized as follows:

CHAPTER 1. PRODUCT DESCRIPTIONS

Provides a general overview and specifications of the product.

CHAPTER 2. OPERATING PRINCIPLES

Describes the theory of electrical and mechanical operations of the product.

CHAPTER 3. TROUBLESHOOTING

Provides the step-by-step procedures for troubleshooting.

CHAPTER 4. DISASSEMBLY AND ASSEMBLY

Describes the step-by-step procedures for disassembling and assembling the product.

CHAPTER 5. ADJUSTMENT

Provides adjusting procedures.

CHAPTER 6. MAINTENANCE

Provides preventive maintenance procedures.

APPENDIX

Provides the following addition information for reference:

- Connector Pin Diagram*
- Circuit Board Component Layout*
- Parts Lists & Exploded Diagrams*
- Circuit Schematics*

Revision Status

Revision	Date of Issue	Description
A	January 7, 2000	First Release
B	February 15, 2000	[Chapter 7 : Appendix] The parts list is added.

Contents

Product Description

Outline	9
Features.....	9
Differences from EPL-5700	10
Basic Specifications.....	10
Printer Basic Specifications	10
Process Specification	13
Paper Specification.....	14
Paper Type	14
Paper Feeding	14
Printable Area (Engine).....	15
Reliability, Durability, Serviceability	15
Operating Conditions Including Consumables.....	17
Storage and Transport Environments Including Consumables	18
Electric Characteristics	18
Applicable Standards and Regulations	19
Consumable Specifications	20
Specifications	20
Storage and Transport Environments.....	20
Controller Specification.....	22
Controller Basic Specification	22
Controller Configuration	23
External I/F specification	24
Parallel Interface.....	24
USB Interface.....	25
Type B Interface.....	25
Control Panel.....	27
Button/LED Arrangements on Control Panel	27
List of Panel Settings.....	28
Setting Items (Model-dependent)	34
Printer Messages	36
Service Call Errors	39
Notes for Operation.....	44
Expansion RAM	44

Powering Off.....	44
High-Temperature Components	44

Operating Principles

Operating Principles of Mechanism.....	46
Paper Path	46
Paper Feed Mechanism	46
Second Paper Feed Unit (Option)	47
Charging Process	49
Overview.....	49
Exposure Process	50
Printable area	51
Development Process	52
Overview.....	52
Transfer Process.....	54
Overview.....	54
Fusing Process.....	55
Overview.....	55
Fusing Temperature Control Circuit.....	55
Paper Eject Process.....	57
Face up / Face down Switching Function.....	57

Troubleshooting

Troubleshooting	59
Troubleshooting for Paper Jam	59
Check Point.....	60
Troubleshooting for Abnormal Operations.....	61
Check Point.....	62
Troubleshooting for Print Quality Problems.....	63

Disassembly and Assembly

Overview	66
Precaution for Disassembly and Assembly.....	66
Precaution at Maintenance and Disassembling	66

Precaution at Handling the Laser Mechanism	66
Handling Forbidden	66
Precaution at Handling the Print Board	66
Precaution at Handling the Photoconductor (Drum Cartridge)	67
Regularly Replacement Parts	68
Service Tools	68
Specification for Screws	68
Disassembly Procedure.....	69
Preparation before disassembling	70
Paper Feed Roller Replacement	70
Transfer Roller Replacement	71
Paper Empty Sensor (PE1) Removal.....	72
Right Cover Removal	72
Control Panel Removal	73
Main Control Board (PWB-P) Removal.....	73
Left Cover and Front Cover Removal.....	74
Paper Feed Solenoid (SL1) Removal	74
Top Cover Removal.....	75
Rear Cover Removal.....	76
Cooling Fan Removal	76
Main Motor Assembly Removal.....	77
Fusing Unit Removal.....	77
Fusing Unit Disassembly	78
Interlock Switch (S2) Removal	80
Print Head Unit (PH) Removal	81
Power Unit (PU1), Paper Feed Sensor (PS1) Removal.....	81
High Voltage Unit (HV1) Removal.....	82
Second Paper Feed Roller Replacement	83
Second Paper Feed Unit Removal	83
Relay Board (PWB-A) Removal	84
Second Paper Size Detection Switch (SW21) Removal.....	85
Second Paper Feed Solenoid (SL21) Removal.....	85

Adjustment

Adjustment.....	87
Print Start Position Adjustment.....	87
Interlock Switch Position Adjustment.....	88
USB ID Input	89

Maintenance

Maintenance	92
User Maintenance on Main Unit	92
Maintenance of Consumables.....	92
Maintenance by Service Technicians	93

Appendix

Overview	95
Connectors	95
Connection diagrams.....	95
Connector List.....	95
Connector Pin Assignment.....	96
Component Layout.....	99
Circuit Schematics.....	100
Parts List.....	104
Exploded View Diagrams.....	107

CHAPTER

1

PRODUCT DESCRIPTION

1.1 Outline

EPSON EPL-5800 is non-impact page printer with semi-conductor laser and electrophotographic technology.

1.1.1 Features

ENGINE FEATURES

- Compact and lightweight, A4 support engine
- Resolution/ printing speed: See table below.

Table 1-1. Resolution and Printing Speed

Resolution	Printing Speed
300dpi / 600 dpi	10ppm
1200 dpi	5ppm

- Standard paper supply includes cassette-like universal paper tray (150 sheets) and manual feed tray (one sheet)
- Option support for 500-sheets lower cassette (A4, Letter size)

CONTROLLER FEATURES

- High-speed controller, employing new CPU
 - CPU = VR4310 / Clock = 133MHz
 - 16 MB fitted as standard RAM and Expandable up to 256MB Max.
- Two standard interfaces
 - IEEE1284 parallel interface
 - USB interface (Windows 2000 supported)
- One Type B interface slot equipped (Level 3 supported)
- Euro Symbol supported

- EnhancedMicroGray installed (available only in 600dpi and 300dpi. automatically Off at 1200dpi)
- RITech installed (available only in 600dpi and 300dpi. Automatically switched Off when 1200dpi is selected.)

SOFTWARE FEATURE

- The following modes and resolution are supported.

Table 1-2. Supporting Modes

Mode	1200dpi	600dpi	300dpi	Note
ESC/Page	○	○	○	
PCLXL	○	○	○	
PCL5e	x	○	○	
ESC/P2	x	○	○	
FX	x	○	○	
1239X	x	○	○	
PostScript	○	○	○	Optional

- NLSP is included in the main unit font ROM
- The number of built-in font added
 - ESC/Page: 49 → 84 fonts
 - PCL: 45 → 80 fonts
- USB Revision 1.1 supported (for Widows 2000 USB PnP)

1.1.2 Differences from EPL-5700

Table 1-3. Differences from EPL-5700

Item	EPL-5700	EPL-5800	Note
Engine speed	8ppm	10ppm	
Real 1200dpi support	x	○	5ppm when 1200dpi is selected.
CPU performance	R4300-100MHz	R4310-133MHz	
RAM capacity (Standard / Maximum)	4MB / 36MB	16MB / 256 MB*1	
RAM type	EDO RAM SIMM	SDRAM DIMM	
Expansion ROM	ROM DIMM x 2	ROM DIMM*2 x 1	For Adobe PS 3 kit
Serial I/F	RS232C	USB	Support USB Revision 1.1.
NLSP	ROM DIMM	Standard	
PCL mode level	PCL5e	PCL6	
Built-in fonts	45	80	For PCL
	49	84	for ESC/Page
NLSP Bitmap3	Option	Standard	Included in the main unit font ROM.
PostScript (Optional)	Clone PS2	Adobe PS3	

*1: Maximum RAM capacity is possible when 256 MB SDRAM DIMM is implemented. Even when 256 MB SDRAM DIMM is implemented, the maximum RAM capacity is limited up to 256MB.

*2: When PS option is implemented, other extension DIMMs (font etc.) cannot to be implemented.

1.2 Basic Specifications

1.2.1 Printer Basic Specifications

Printing Method: Electrophotographic process using semiconductor laser beam scanning and dry mono-component toner

Resolution: 600dpi / 1200dpi
(1200dpi is half speed control)

Printing Speed: See table below.

Table 1-4. Printing Speed

Paper Size	600dpi		1200dpi	
	Main Unit	Lower Cassette Unit*1	Main Unit	Lower Cassette Unit*1
A4 or LT	10PPM minimum	10PPM minimum	5PPM minimum	5PPM minimum
LGL	8.4PPM minimum	--	4.2PPM minimum	--
B5	10PPM minimum	--	5PPM minimum	--
A5	10PPM minimum	--	5PPM minimum	--

*1: Printing speed is lower when printing custom paper size because the automatic cleaning is carried out.

First Print: See table below.

Table 1-5. First Print

Paper Size	600dpi		1200dpi	
	Main Unit	Lower Cassette Unit*1	Main Unit	Lower Cassette Unit*1
A4 or LT	18sec maximum	19sec maximum	27sec maximum	29sec maximum
LGL	19sec maximum	--	29sec maximum	--
B5	18sec maximum	--	26sec maximum	--
A5	18sec maximum	--	24sec maximum	--

*1: Printing speed is lower when printing custom paper size because the automatic cleaning is carried out.

Warm-up Time: [At 23°C, rated voltage]

- 22sec Max.
(From when powered on until "Ready" is displayed)
- 10sec Max.
(Recovering from Standby mode)

Paper Supply: See table below.

Table 1-6. Paper Supply

Paper Feed Method	Capacity	Paper Size	Paper Thickness
Paper Tray (Fixed)	150 sheets*1	Standard or custom paper sizes within the following ranges; 76.2x127 to 215.9x355.6mm (A4, JIS-BIDS, A5, Letter, Government Letter, Executive, Legal, Government Legal, F4, Half Letter)	Plain paper 60 to 90 g/m ² (16 to 24 lb)
	10 sheets	Envelops (Monarch, C10, DL, C5, C6, International-B5, Labels, Transparencies, Thick Papers)	Plain paper 60 to 90 g/m ² (16 to 24 lb) Thick paper 90 to 163 g/m ² Special paper (Labels, Transparencies)
Manual feed slot*2	1 sheet	Standard or custom paper sizes within the following ranges; 100x148 to 215.9x355.6mm	Plain paper 60 to 90 g/m ² (16 to 24 lb) Thick paper 90 to 163 g/m ² Special paper (Labels, Transparencies)
Lower Cassette Unit*1,*3	500 sheets*1	A4 or LT	Plain paper 60 to 90 g/m ² (16 to 24 lb)

*1: Using 75 g/m² (20lb) paper

*2: Feed one sheet at a time from the top of the paper tray when manual feed.

*3: The fixe size cassette (A4 or LT) can be installed. Maximum paper capacity including the paper tray is 650 sheets.

Paper Size: See table below.

Table 1-7. Paper Size

Paper	Size	Paper Size (mm / inch)	Paper Tray	Manual Feed Slot	Lower Cassette Unit* ¹
Plain paper	A4	210x297	○	○	○
	A5	148x210	○	○	
	JIS-B5	182x257	○	○	
	LT	215.9x279.4 (8.5x11")	○		○
	HLT	139.7x215.9 (5.5x8.5")	○	○	
	LGL	215.9x355.6 (8.5x14")	○	○	
	EXE	184.15x266.7 (7.25x10.5")	○	○	
	GLG	215.9x330.2 (8.5x13")	○	○	
	GLT	203.2x266.7 (8x10.5")	○	○	
	F4	210x330	○	○	
3"x5"	76.2x127 (3x5")	○			
Special paper	MON	98.43x190.5 (37/8x7 1/2")	○	○	
	C10	104.78x241.3 (41/8x9 1/2")	○	○	
	DL	110x220	○	○	
	C5	162x229	○	○	
	C6	114x162	○	○	
	I-B5	176x250	○	○	
	16MO	198x275	○	○	

*1: Supported size differs according to the market destination

Consumables:

- Toner cartridge (user replaceable)
- Photoconductor unit (user maintenance item)

Applicable paper sizes:

- Paper tray:

paper width	76.2mm (3 inch) to 215.9mm (8.5 inch)
paper length	127mm (5 inch) to 355.6mm(14 inch)
- Manual feed slot:

paper width	110mm (3.9 inch) to 215.9mm (8 inch)
paper length	148mm (5.8 inch) to 355.6mm(14 inch)
- 2nd cassette: Supported paper size = A4, Letter

Paper-feed reference: Center line reference for each paper size

Output paper capacity: [Face-down]
Max. 100 sheets
(with standard paper immediately after unpacked)

[Face-up]
Max. 20 sheets
(with standard paper immediately after unpacked)

* Switching between face-up/face-down is made by manually operating the lever on the top of the printer.

Dimensions: 387W x 475D x 338 H (mm)
(Main unit only)

Weight: Approx. 7kg
(excluding consumables or options)

Power Supply:

- 100V model (compatible with 100/120V supply)
120V \pm 10% 50/60Hz 3Hz
- 200V model (compatible with 100/120V supply)
220V~240V \pm 10% 50/60Hz 3Hz

Power Consumption: See table below.

Table 1-8. Power Consumption

		100V model	200V model	220V to 240V model
Max. rated current (TBD)		7.0A	5.9A	3.2A
Power Consumption	Maximum	660W	690W	700W
	Continuous printing, average	270W	270W	270W
	Standby actual value (TBD)	Heater ON	50W	50W
Heater OFF		15W	15W	15W

Life: 180,000 sheets or 5 years, whichever comes first.

Noise: [During standby]
30 db(A) max. (4-directional average)
[During operation]
48 db(A) max. (4-directional average) (T.B.D)

Ozone Concentration: 0.02 ppm max.

Toxicity: OPC, toner, and plastic materials are all non-toxic.

1.2.2 Process Specification

Method:	Electrophotographic method using dry mono-component developing
Light source:	Semiconductor laser
Exposure:	OPC (organic photoconductor) drum
Charging:	Rotary-brush charging method
Developing:	Exposed area development
Toner:	Mono-component non-magnetic toner
Transfer method:	Roller Transfer
Fusing:	Heat and pressure roller system
Density adjustment:	Bias variable adjustment by user is possible

1.2.3 Paper Specification

1.2.3.1 Paper Type

Standard paper: Xerox 4024 DP paper 20 lb (75 g/m²)

Plain paper: 60 ~ 90 g/m² (16 ~ 24 lb)
 Photocopier paper, bond paper, recycled paper

Special paper:

- Labels
- Transparencies
- Colored paper
- Thick paper (90 to 163 g/m²)
- DTP paper
- Letter-head

NOTE: lb: Ream weight= lb/500 sheets/17"x22"
 g/m²: 1 g/m²=0.2659763 lb



Do not use any of the paper types listed below with this printer. They may cause defective printing, paper jams, or damage to the printer.

- Carbon paper, non-carbon paper, thermal paper, pressure-sensitive paper, acidic paper.
- Paper previously printed in a thermal printer or inkjet printer.
- Extra thick or extra thin paper.
- Damp paper.
- Surface-coated paper or surface-treated color paper.
- Extra smooth or glossy paper. Extra rough paper. Paper with significantly different roughness on each surface.
- Paper with punched holes or perforations.

- Folded, curled, or torn paper.
- Irregularly shaped paper or paper with non-perpendicular corners.
- Sheets of labels that peel off easily.
- Paper with glue, staples, or clips attached.
- Special inkjet paper superfine paper, glossy film, etc.
- OHP film for color laser printers or photocopiers.
- Sheets already printed on other color or black/white laser printers or photocopiers.
- Sheets of paper stuck together.

NOTE: When printing on pre-printed papers, the paper may not feed correctly due to paper particles adhering to the paper-feed roller. If this occurs, clean the printer as described in 6.1.1 "User Maintenance on Main Unit".

1.2.3.2 Paper Feeding

Table 1-9. Paper Feeding

Paper source	Standard paper	Plain paper (60 to 90 g/m ²)	Special paper			
			OHP	Labels	Thick paper (90 to 163 g/m ²)	Envelops (MON, C10, DL, C5, C6)
Paper tray	○	□	△	△	△	△
Lower cassette unit*	○	□	x	x	x	x

- : Paper feeding reliability and image quality guaranteed.
- : Paper feeding reliability and image quality guaranteed. Restricted to normally used paper types only.
- △: Paper feeding and printing are possible. Restricted to normally used paper types only.
- x: Paper feeding not possible.
- *: Option

1.2.3.3 Printable Area (Engine)

Guaranteed print area: Entire paper area except for a 4 mm margin at each edge.
(See Figure 1-1, "Guaranteed print Area").

NOTE: The printable area may depend on the printer mode.

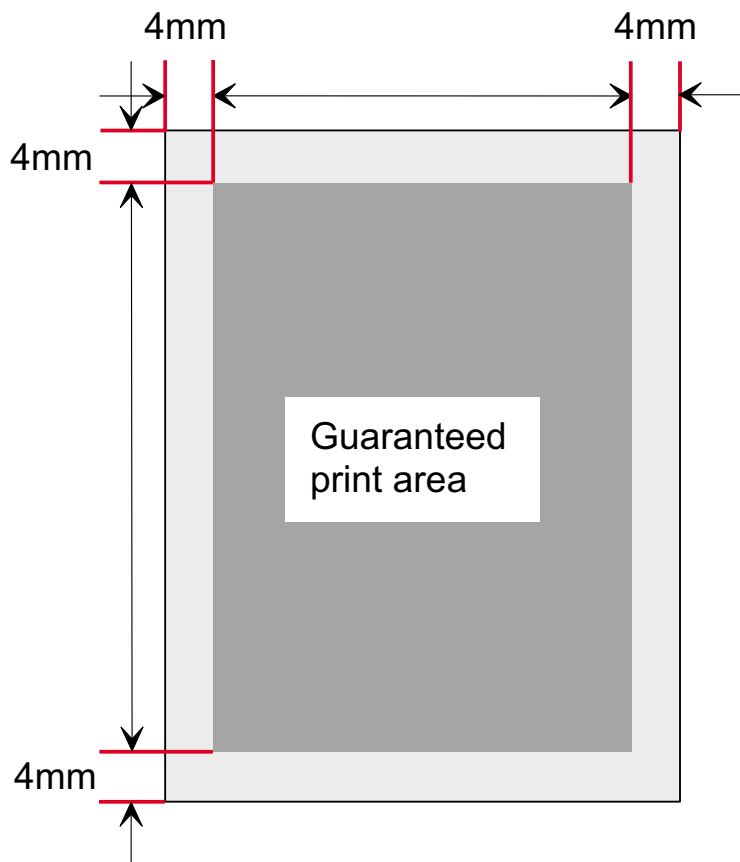

Figure 1-1. Guaranteed print Area

1.2.4 Reliability, Durability, Serviceability

MPBF: 25, 000 sheets min. one-sided printing

Note:
This figure indicates the mean pages until a failure requiring part replacement or a failure that the user cannot remedy.

MTBF: 3,000 hours (10 month) minimum

Paper Feeding: See table below.
Applicable conditions for the following figures is using standard paper under standard environmental conditions.

Table 1-10. Paper Feed Reliability

Error type	Paper Tray	Lower Cassette Unit
Paper-jam rate*1	1/2000 max.	←
Paper misfeed	1/2000 max.	←
Multiple-sheet feed rate	1/500 max.	←
Paper creasing	1/1000 max.	←
Leading edge folded	1/1000 max. for 1C or more. Less than 1C not included.*2	←

*1: Not including multiple-sheet feed.

*2: 1C indicates 1mm corner fold.

Printing start position accuracy:

- Main scan direction: Reference position (c) ± 2.0 mm
 - Sub scan direction: Reference position (a) ± 2.5 mm
- See Figure 1-2, "Paper Skew".

Paper skew: With A4 landscape;

- Main scan direction (lc-dl): ± 2.0 mm
- Sub scan direction (la-bl): ± 1.5 mm

See Figure 1-2, "Paper Skew".

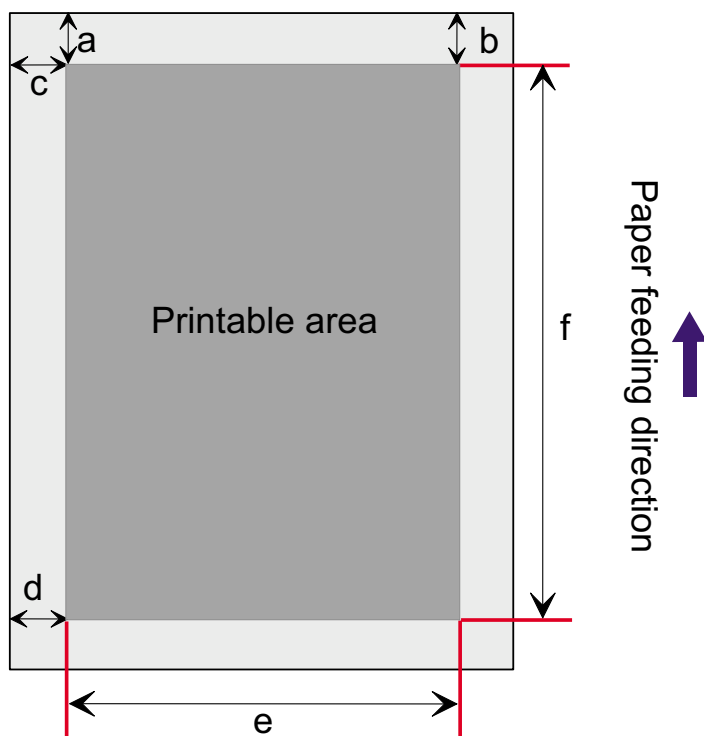

Figure 1-2. Paper Skew

Durability:

5 years or 180,000 sheets, whichever comes first.
Including parts replaced by service technicians.
(See 6.1.3 "Maintenance by Service Technicians")

Serviceability:

MTTR = 30 minutes max.
(Time for service technician to locate and repair a failure.)

Output paper curl height:

- Plain paper: ± 30 mm max.
- OHP: ± 20 mm max.

1.2.5 Operating Conditions Including Consumables

Temperature:	10 to 35 °C
Humidity:	15 to 85% RH (without condensation)
Barometric pressure (altitude):	760 hPa min. (2500 meters max.)
Horizontality:	Max. 1° tilt front -rear or left-right
Illumination:	3,000 lx max. (no direct sunlight)
Surrounding space:	Keep the space shown in the figures below around the printer to ensure normal printer operation. (Units: mm)

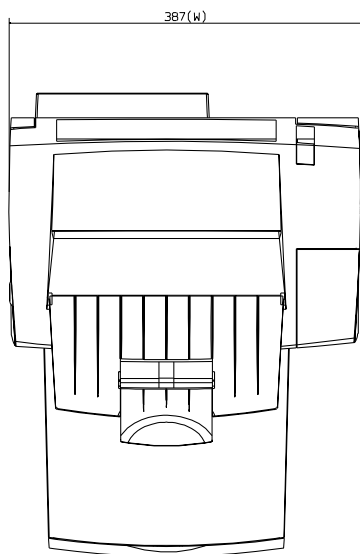

Figure 1-3. Top View

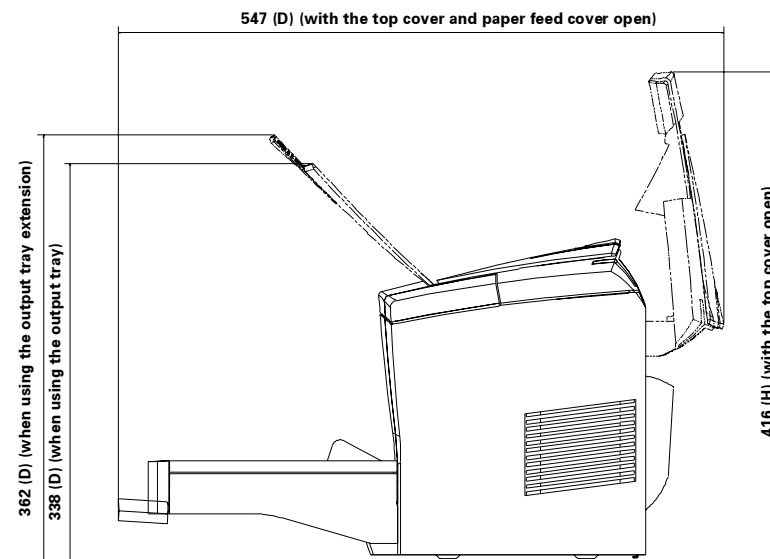

Figure 1-4. Right View

NOTE: Additional space of 150mm is necessary on the backside of the printer when the Face-up tray is installed.

NOTE: Additional space of 125mm is necessary over the printer when the Lower cassette unit is installed.

1.2.6 Storage and Transport Environments Including Consumables

Temperature and humidity: See table below.

Table 1-11. Temperature and Humidity Conditions

Conditions		Main Unit	
Temperature	Normal conditions	0 to 35 °C	
	Severe conditions (1/30 of total storage period)	High temperature	0 to 40 °C
		Low temperature	-20 to 0 °C
Humidity	Normal Conditions	30 to 85% RH	
	Severe conditions (1/30 of total storage period)	High humidity	85 to 95% RH
		Low humidity	10 to 30% RH
Storage period		18 months from manufacture	

Barometric pressure: 460 to 760 hPa

Dropping: No abnormalities according to JIS Z0200-1994 Level 1.
Free drop directions: 1 corner, 6 faces, 3 edges

Vibrations:

- Frequency 5 to 100 Hz, 100 to 5 Hz
- Acceleration 1G
- Sweep time 10 minutes (each way)
- Direction of vibrations 3 directions
- Vibration time 60 minutes in X, Y, Z directions (total 180 minutes)

1.2.7 Electric Characteristics

These items do not include the options.

AC line noise:

- Pulse width: 50 to 1000 ns
- Pulse polarity: +/-
- Repetition: asynchronous
- Modes: common/normal
- Voltage: 1kv (no component damage to 2kv)

Transient outage: DIP 100% (at rated voltage-10%) for one cycle with normal print quality.

Electrostatic tolerance:

- Up to ± 10 kv: No hardware error
- Up to ± 15 kv: No component damage

Surge current: 1/2 cycle, 50A max.

Insulation resistance: 10 M Ω min.

Dielectric strength: No breakdown when the following voltages are applied for one minute.

- 100V model: AC 1000V (Primary to chassis)
- 200V model: AC 1500V (Primary to chassis)

Leakage current:

- 100 V model, 100 V input: 0.25mA or less
- 100V model, 100 V input: 3.5mA or less
- 200V model: 3.5mA or less

1.2.8 Applicable Standards and Regulations

The engine specification meets the following standards and regulations. According to their intended destination, some standards and regulations apply to a product with controller.

SAFETY STANDARDS

Table 1-12. Safety Standards

Model Name	Applicable Standard
100V model	UL 1950 3rd CSA 22.2 No.950
200V model	TÜV-GS (EN60950) CCIB, Russian Safety Standards, Singapore Safety Standards, Hong Kong Safety Standards (IEC950)

SAFETY REGULATIONS (LASER RADIATION)

Table 1-13. Safety Regulations (Laser Radiation)

Model Name	Applicable Standard
100V model	FDA (NCDRH) Class1
200V model	TÜV-GS (EN60825-1)

EMC

Table 1-14. EMC

Model Name	Applicable Standard
100V model	CNS 13438 (Taiwan) FCC Part 5 Subpart B Class B/CSA C108.8 Class B
200V model	EC, EMC Directive 89/336/EEC EN61000-3-2 EN61000-3-3 EN50082-1 CISPR 24 AS/NZS 3548 Class B (Australia) GB9254 (CISPR 22) (China)

Power consumption: Complies with International Energy Star Program standards.

Others:

- Toner: No effects on human health (OSHA, TSCA, INECS, Labor Safety Law, CSCL.)
- OPC: No effect on human health (OSHA)
- Ozone: UL478 (5th edition)
- Materials: SWISS environmental laws (not including Cds)

1.2.9 Consumable Specifications

1.2.9.1 Specifications

Table 1-15. Consumable Specifications

Name	Contents	Life*1	Weight
Developer and Toner cartridge	-Developer -Black, one-component, non-magnetic toner	Average 6,000 sheets	approx. 0.5 kg
Photoconductor unit	-OPC drum (organic photoconductive conductor) -Charger	Average 20,000 sheets	approx. 0.3 kg

*1: These figures for printed sheets are based on continuous printing of A4 size sheets with 5% image coverage. Actual usage will vary depending on image coverage and printing conditions such as continuous printing, intermittent printing, saturated printing and toner save.

1.2.9.2 Storage and Transport Environments

Temperature and humidity conditions:

Table 1-16. Temperature and Humidity Conditions

Conditions		Toner Cartridge and Photoconductor Unit	
Temperature	Normal conditions	0 to 35 °C	
	Severe conditions (1/30 of total storage period)	High temperature	35 to 40 °C
		Low temperature	-20 to 0 °C
Humidity	Normal Conditions	30 to 85% RH	
	Severe conditions (1/30 of total storage period)	High humidity	85 to 95% RH
		Low humidity	10 to 30% RH
Barometric pressure		61.3 to 101.3 kPa	
Storage period		18 months from manufacture (Packed)	

Dropping: No abnormalities according to JIS Z0200-1994 Level 1.
Free drop directions: 1 corner, 6 faces, 3 edges

Vibrations:

- Frequency 5 to 100 Hz, 100 to 5 Hz
- Acceleration 1G
- Sweep time 10 minutes (each way)
- Direction of vibrations 3 directions
- Vibration time 60 minutes in X, Y, Z directions total 180 minutes

1.3 External Appearance and Parts Name

The following illustrations are top, right and left, and back views of the unit.

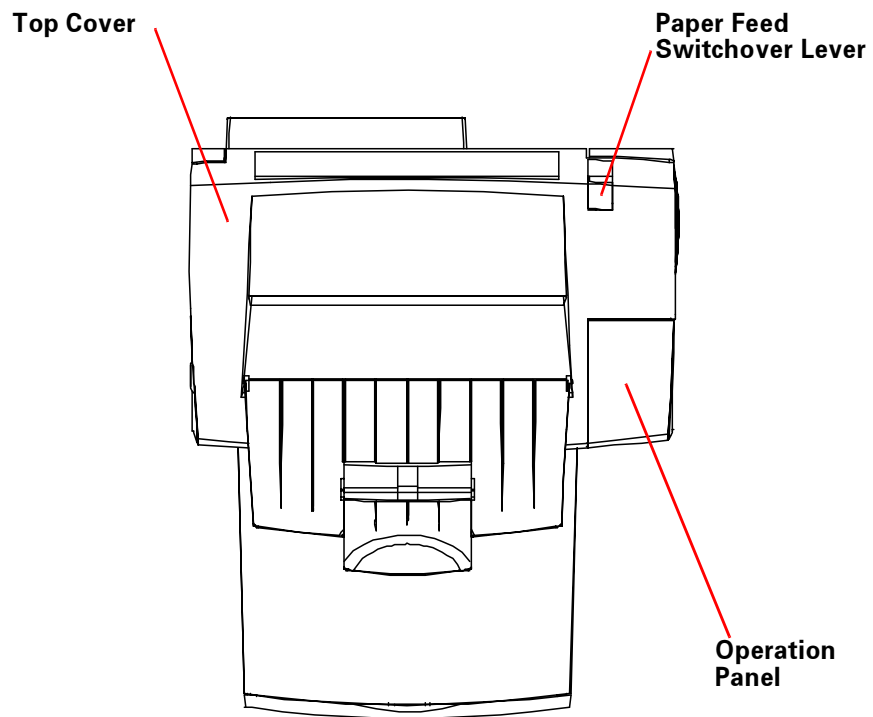

Figure 1-5. Top View

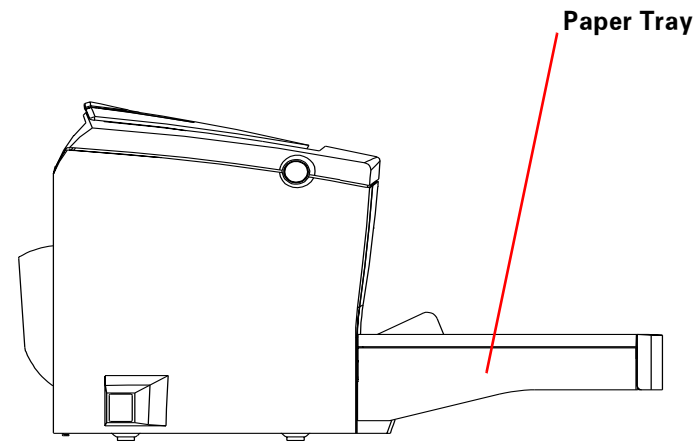

Figure 1-6. Left View

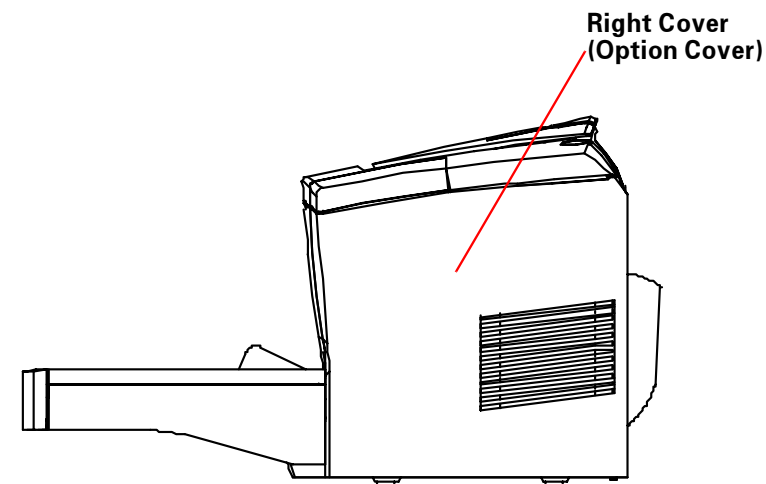

Figure 1-7. Right View

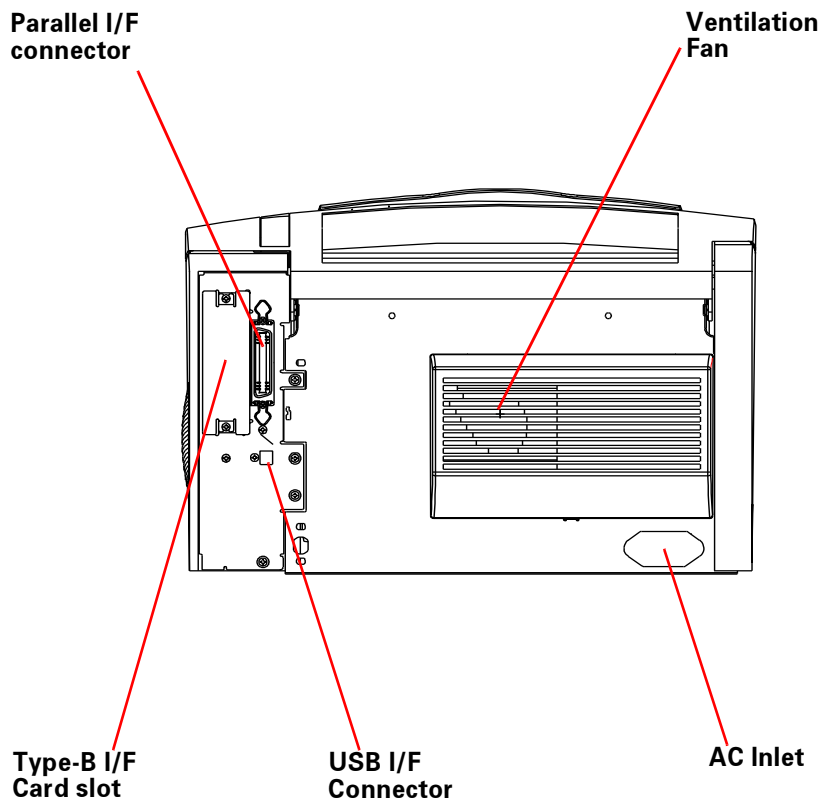

Figure 1-8. Back View

1.4 Controller Specification

1.4.1 Controller Basic Specification

CPU: VR 4310 133MHz

RAM:

- Standard: 16MB (SDRAM)
- SIMM Option: 32MB, 64MB, 128MB (SDRAM, one slot)
Maximum 256MB
(when 256MB SDRAM DIMM mounted)

ROM:

- Font: 4Mbyte (mounted on main board)
- Program: 4Mbyte (mounted on ROM DIMM board)
- Expansion ROM: one ROM DIMM slot (for PS option)

Host I/F:

- Parallel: IEEE1284 compliant, bidirectional, B-type connector, Compatibility, Nibble, ECP
- Serial: USB
- Option: Type B slot (one slot)

Control Panel: 4 switches, 6 LED

Miscellaneous: Embedded engine controller

Installed emulations: PCLXL, PCL5e, GL/2, FX, ESCP2, 1239X, ESC/Page*1, PostScript3*2

*1: The IES does not support ESC/Page. Only the ESC/Page driver can print ESC/Page.

*2: PostScript3 is an option.

1.4.2 Controller Configuration

EPL-5800 controller allows the following settings to be configured according to the market destination. The settings are made with jumpers, and must thus be set at the factory.

JUMPER SETTING

- Packaged resistance
RJ2, RJ3, RJ5, RJ7, RJ10, RJ12, RJ13
- Unpackaged resistance
RJ1, RJ4, RJ6, RJ8, RJ9, RJ11, RJ14
- Packaged
JP7
- Unpackaged
SWD1, JP6
- JP7
1-2 side

DESTINATION SETTINGS A4/LETTER SELECTION

- For North and South America/ 120V model: Letter setting
- Other destinations: A4 setting

1.4.3 External I/F specification

EPL-5800 has the following host interfaces as standard.

- IEEE1284 parallel interface
- USB interface
- Optional Type-B I/F Card slot

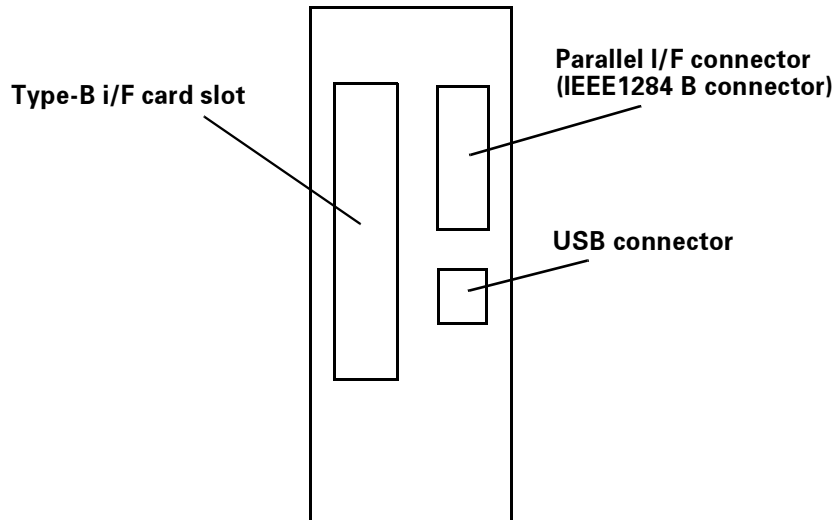

Figure 1-9. Rear View (Interface bracket)

1.4.3.1 Parallel Interface

Interface type:	IEEE1284 bi-directional high-speed parallel I/F
Supported modes:	Compatibility, Nibble, ECP
Connector Type:	57RE-40360-830B(D7A) DDK or equivalents
Compatible plug:	Amphenol or equivalents

The default device ID setting for EPL-5800 is as follows.

```

***1;
MFG:EPSON;
CMD:PJL,EJL,ESCPL2,PRPXL24-01,PCL,HPGL2-01,ESCPAGE-
04,PCLXL ***2;
MDL:***3;
CLS:PRINTER;
DES:***4;

```

MFG, MDL, CID of Device ID are re-definable. (this must not be included in the manual.) And CID field does not respond with the default value, but responds with the defined character string only when redefined.

Device ID when redefined is as follows. "xxxxx" is user-defined character string.

```

***1;
MFG:xxxxx;
CMD:PJL,EJL,ESCPL2,PRPXL24-01,PCL,HPGL2-01,ESCPAGE-
04,PCLXL ***2;
MDL:xxxxx;
CLS:PRINTER;
DES:xxxxx;
CID:xxxxx;

```

NOTE:

- *1: The hexadecimal value "the total number of Device ID characters + 2" is input.
- *2: Following text string is added when Adobe PS 3 kit ROM DIMM option is installed.

“,POSTSCRIPT”

- *3: The model name **EPL-5800**
- *4: DES is the text string that MFG and MDL is connected by a space.

“EPSON EPL-5800” for EPSON EPL-5800.

1.4.3.2 USB Interface

Supports Windows USB PnP.

Supports the 18-digit USB ID as follows:

****P++YYMMDDhhmmssR**

- **:
- A number of 00 to 99 and "01" is assigned for this model. Acquired in serial order for each model.
- P:
- Identifier. "P" indicates a page printer. Always "P" for page printers.
- ++:
- PC number of assembly line. (00~99)
- YY:
- The year of assembled date. (lower two digits; 00~99)
- MM:
- The month of assembled date. (1~12)
- DD:
- The assembled date (1~31)
- hh:
- Hour of assembled time. (0~23)
- mm:
- Minute of assembled time. (0~59)
- ss:
- Second of assembled time. (0~59)
- R:
- Reserved and always "0" in this model.

Device ID in Printer Class conforms to 1.4.3.1 "Parallel Interface"..

CAUTION



The USB ID is stored on EEPROM of the main board, and you have to re-assign the ID when you replace the main board to new one in repair.
Refer to Chapter 5 "Adjustment" for the details.

1.4.3.3 Type B Interface

EPL-5800 is equipped with one Type-B option I/F slot as standard.

- Main System Type: MTP1200dpi, PW10200dt1200dpi, PRG(****)rev, AP500ma, SPD0fast, D4
****: ROM version
- Printer Name: Factory default setting is the same as one of Product Name.
- Product Name: EPL-5800
- Emulation Type: See the Table 1-17.
- Entity Type: See the Table 1-17.

Table 1-17. Emulation Type and Entity Type

Emulation	Emulation Type	Entity Type
PCLXL	PCLXL	EPSONPCLXL
LJ4	PCL5E-00	EPSONPCL5
GL/2	HPGL2-01	EPSONHPGL2
PS	POSTSCRIPT-00	LaserWriter
FX	ESCP9-84	EPSONFX
ESCP2	ESCPL2-00	EPSONLQ2
1239X	PRPXL24-01	EPSONPRPXL24
ESC/Page	ESCPAGE-04	EPSONPAGE4

- When Emulation is set to “Auto”, the following Entity Type will be returned.
 - If PS is not installed;
EPSONPAGE4, EPSONCL5, EPSONLQ2, EPSONHPGL2, EPSONFX,
EPSONPRPXL24
 - If PS is installed;
LaserWriter, EPSONPAGE4, EPSONPCL5, EPSONLQ2,
EPSONHPGL2, EPSONPRPXL24
- When Emulation is fixed, the following Entity Type will be returned.
 - Default Emulation: EPSONPAGE4

NOTE: *The number of entity types returned to the host depends on the specification of Type B interface.*

- Emulation Type
 - If Emulation is set to Auto;
If PS3 is OFF: AUTO (Emulation Type 1, 2, 3...)
If PS3 is ON: EJP (POSTSCRIPT-00, other Emulation Type 1, 2, 3...)
 - If Emulation is fixed;
EJP (Default Emulation, other Emulation Type 1, 2, 3...)

1.5 Control Panel

1.5.1 Button/LED Arrangements on Control Panel

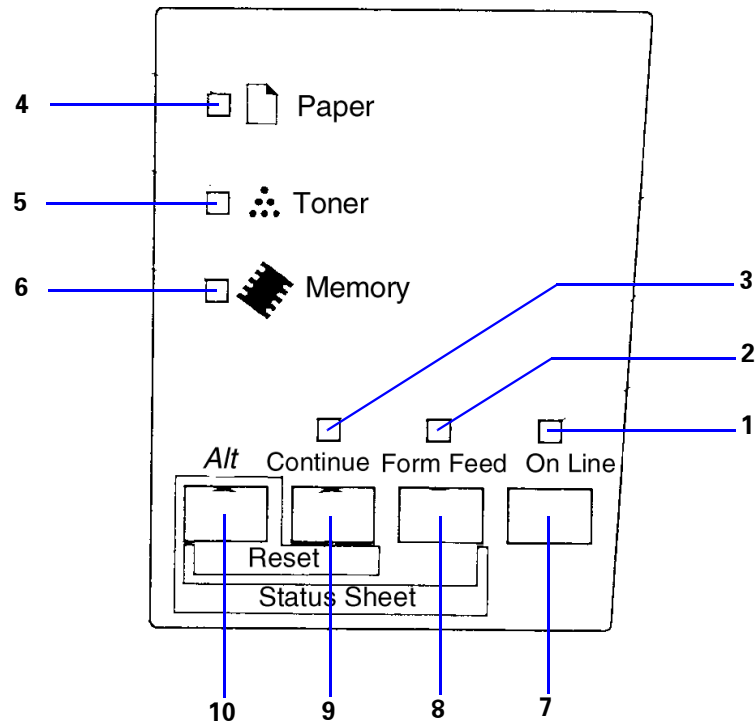

Figure 1-10. Control Panel

NOTE: For Taiwan and China, the panel sheet is written in each language.

Table 1-18. Buttons and LEDs

No.	Name	Note
1	On line LED	Color: Green
2	Data LED	Color: Yellow
3	Continue LED	Color: Red
4	Paper LED	Color: Yellow
5	Toner LED	Color: Yellow
6	Memory LED	Color: Yellow
7	On Line switch	
8	Form Feed switch	
9	Continue switch	
10	Alternate switch	

1.5.2 List of Panel Settings

EPL-5800 has no LCD on the control panel, so it is impossible to make function settings from the control panel. Function settings can be made using "RCP". The following tables are lists of the printer setting items. Underline indicates the factory default setting.

□ Function Setting (1)

Table 1-19. Function Setting (1)

Menu	Item	Value
Test Menu	Status Sheet	
	AUX Status Sheet* ³	
	PS3 Status Sheet* ¹	
	PS3 Font Sample* ¹	
	ESC/Page Font Sample* ²	
	LJ4 Font Sample	
	ESCP2 Font Sample	
	FX Font Sample	
	I239X Font Sample	
Emulation Menu	Parallel	<u>Auto</u> , LJ4, ESCP2, FX, I239X, PS3* ¹ , GL2
	USB	<u>Auto</u> , LJ4, ESCP2, FX, I239X, PS3* ¹ , GL2
	AUX* ³	<u>Auto</u> , LJ4, ESCP2, FX, I239X, PS3* ¹ , GL2

Table 1-19. Function Setting (1)

Menu	Item	Value
Printing Menu	Paper Source	<u>Auto</u> , MP, LC* ⁴
	Page Size	<u>A4</u> * ⁵ , A5, B5, <u>LT</u> * ⁵ , HLT, LGL, GLT, GLG, EXE, F4, MON, C10, DL, C5, C6, IB5, CTM
	Wide A4	<u>Off</u> , On
	Orientation	<u>Port</u> , Land
	Copies	<u>1</u> -999
	Quantity* ⁶	<u>1</u> -999
	Manual Feed	<u>Off</u> , On
	Resolution	<u>600</u> , 1200* ⁷ , 300
	Dot Correction	<u>Off</u> , On
Tray Menu	Skip Blank Page* ⁸	<u>Off</u> , On
	Auto Eject Page	<u>Off</u> , On
	MP Mode	<u>Normal</u> , Last
	MP Tray Size	<u>A4</u> * ⁵ , A5, B5, <u>LT</u> * ⁵ , HLT, LGL, GLT, GLG, EXE, F4, MON, C10, DL, C5, C6, IB5
	LC Size* ⁴	<u>A4</u> , LT
	MP Type	<u>Plain</u> , Preprinted, Letterhead, Recycled, Color, Trnspncy, Labels
	LC Type* ⁴	<u>Plain</u> , Preprinted, Letterhead, Recycled, Color

Table 1-19. Function Setting (1)

Menu	Item	Value
Config Menu	RItech*9	<u>On</u> , Off
	Toner Save	<u>Off</u> , On
	Density	<u>3</u> , 4, 5, 1, 2
	Top Offset	-99.0 ~ <u>0.0</u> ~ 99.0mm (0.5mm increments)
	Left Offset	-99.0 ~ <u>0.0</u> ~ 99.0mm (0.5mm increments)
	Size Ignore	<u>Off</u> , On
	Auto Cont	<u>Off</u> , On
	Page Protect	<u>Auto</u> , On
	Image Optimum	<u>Auto</u> , Off, On
Paper Type*10	<u>Normal</u> , Thick W, Thick N, Trnspnc	
Setup Menu	Time out	0, 5 ~ <u>60</u> ~ 300
	Standby	<u>Continue</u> , Stop
	Lang	<u>English</u> , Française, Deutsch, ITALIANO, ESPANOL, SVENSKA, Dansk, Nederl, SUOMI, Português
	Toner	E****F, E***□F, E**□□F, E*□□□F, E□□□□F
	Toner Out	<u>Disable</u> , Enable
	SelecType Unit	0 ~ 99999999
Parallel Menu	Parallel I/F*11	<u>On</u> , Off
	Speed	<u>Fast</u> , Normal
	Bi-D	<u>Nibble</u> , ECP, Off
	Buffer Size*11	<u>Normal</u> , Maximum, Minimum
USB Menu	USB I/F*3	<u>On</u> , Off
	Buffer Size*11	<u>Normal</u> , Maximum, Minimum

Table 1-19. Function Setting (1)

Menu	Item	Value
AUX Menu*12	AUX I/F*11	<u>Use</u> , No Use
	AUX Config*13	<u>No</u> , Yes
	Buffer Size*11	<u>Normal</u> , Maximum, Minimum

NOTE:

- *1: This item can be selected only when the optional Adobe PS 3 kit is installed.
- *2: Cannot be selected / changed by RCP etc. and is not printed on the Status Sheet.
- *3: This item can be selected only when the Type B I/F option is installed.
- *4: Displayed only when the optional lower cassette unit is installed. Paper sizes are display only.
- *5: LT= default value for Letter-model controller
A4= default value for A4-model controller
- *6: Can be set only with the printer driver. Not printed on Status Sheet. Can be to set with EJL or PjL, but it is valid only when the installed RAM is 64MB or more. (The firmware does not verify the installed RAM capacity, but the printer driver does. This must not be stated in the manual.)
- *7: Effective only for ESC/Page, PCLXL and PostScript. When other mode is selected, it will be printed in 600dpi.
- *8: Valid for PCL5e, ESC/Page, ESC/P2, FX and 1239X.
- *9: When resolution is set to 1200dpi by mode setting, RItech becomes OFF regardless of this item.
- *10: TBD
- *11: When this item is changed, reading with EJL and printing on the Status Sheet are immediately reflected, but become valid after warm boot or at power on again.
- *12: Appears only when the optional Type B interface card is installed. Network card configurations cannot be made from the printer side. Use the utility that comes with each card.
- *13: Display only when Type B Level 3 card is installed. This value cannot be changed and always set to "No".

□ Function setting (2)

Table 1-20. Function Setting (2)

Menu	Item	Value
ESC/Page Menu*1	Auto CR	<u>On</u> , Off
	Auto FF	<u>On</u> , Off
	CR Function	<u>CR</u> , CR+LF
	LF Function	<u>CR+LF</u> , LF
	FF Function	<u>CR+FE</u> , FF
	Error Code	<u>Ignore</u> , Space
	Avoid Error	<u>Off</u> , On
	PGI	<u>On</u> , Off

Table 1-20. Function Setting (2)

Menu	Item	Value
LJ4 Menu	Font Source	<u>Resident</u> , DIMM, Download
	Font Number	<u>0</u> ~ available (Max 65535)
	Pitch*2	0.44 ~ <u>10.00</u> ~ 99.99 cpi (0.01 cpi increments)
	Height*2	4.00 ~ <u>12.00</u> ~ 999.75 pt (0.25 pt increments)
	SymSet*10	<u>IBM-US</u> , Roman-8, Roman-9, ECM94-1, 8859-2 ISO, 8859-9 ISO, 8859-10 ISO, 8859-15 ISO, PcBlt775, IBM-DN, PcMultiling, PcE. Europe, PcTk437, PcEur858, Pc1004, WiAnsi, WiE. Europe, WiTurkish, WiBALT, DeskTop, PSText, VeInternati, VeUS, MsPublishin, Math-8, PsMath, VeMath, PiFont, Legal, UK, ANSI ASCII, Swedis2, Italian, Spanish, German, Norweg1, French2, Windows, McText, Pclcelandic, Pclt774, PcTurk1, PcPortugues, PcET850, PcTurk2, PcCanFrench, PcS1437, PcNordic, 8859-3 ISO, 8859-4 ISO, WinBaltic, WiEstonian, WiLatvian, Mazowia, CodeMJK, BpBRASCI, BpAbicom, PcGk437, PcGk851, PcGk869, 8859-7 ISO, WiGreek, Europe3, PcCy855, PcCy866, Pclt866, 8859-5 ISO, WiCyrillic, Bulgarian, PcUkr866, Hebrew7, 8859-8 ISO, Hebrew8, PcHe862, Arabic8, PcAr864, 8859-6 ISO, OCR A, OCR B
	Form	5 ~ <u>60</u> *3 ~ <u>64</u> *3 ~ 128 Lines
	Source SymSet	0 ~ <u>277</u> ~ 3199
	Dest Symset	0 ~ <u>277</u> ~ 3199
	CR Function	<u>CR</u> , CR+LF
	LF Function	<u>LF</u> , CR+LF
	Tray Assign	<u>4</u> , 4K, 5S

Table 1-20. Function Setting (2)

Menu	Item	Value
GL2 Menu	GL-Mode	GLlike, <u>LJ4GL2</u>
	Scale	<u>Off</u> , A0, A1, A2, A3
	Origin	<u>Corner</u> , Center
	Pen	<u>Pen0</u> , Pen1, Pen2*4, Pen3*4, Pen4*4, Pen5*4, Pen6*4
	End	<u>Butt</u> , Square, Triangular, Round
	Join	<u>Miterend</u> , Meteredbeveled, Triangular, Round, Beveled, None
	Pen0	0.05 ~ <u>0.35</u> ~ 5.00 mm (0.05 mm Increments)
	Pen1	0.05 ~ <u>0.35</u> ~ 5.00 mm (0.05 mm Increments)
	Pen2*4	0.05 ~ <u>0.35</u> ~ 5.00 mm (0.05 mm Increments)
	Pen3*4	0.05 ~ <u>0.35</u> ~ 5.00 mm (0.05 mm Increments)
	Pen4*4	0.05 ~ <u>0.35</u> ~ 5.00 mm (0.05 mm Increments)
	Pen5*4	0.05 ~ <u>0.35</u> ~ 5.00 mm (0.05 mm Increments)
Pen6*4	0.05 ~ <u>0.35</u> ~ 5.00 mm (0.05 mm Increments)	
PS Menu*5	Error Sheet	<u>Off</u> , On

Table 1-20. Function Setting (2)

Menu	Item	Value
ESCP2 Menu	Font	Courier, Prestige, Roman, Sans serif, Roman T, Orator S, Sans H, Script, OCR A, OCR B
	Pitch	10cpi, 12cpi, 15cpi, Prop.
	Condensed	Off, On
	T. Margin	0.40 ~ 0.50 ~ 1.50 inch (0.05 inch increments)
	Text	1 ~ <u>62</u> *6 ~ <u>66</u> *7 ~ available (Max 81) Lines
	CGTable	<u>PcUSA</u> , Italic, PcMultilin, PcPortugue, PcCanFrenc, PcNordic, PcTurkish2, PclceLandic, PcE.Europe, BpBRASCI, BpAbicom, Roman-8, PcEur858, ISO Latin1, 8859-15 ISO, PcS1437, PcTurkish1, 8859-9 ISO, Mazowia, CodeMJK, PcGk437, PcGk851, PCGk869, 8859-7 ISO, PcCy855, PcCy866, Bulgarian, PcUkr866, Hebrew7, Hebrew8, PcAr864, PcHe862
	Country	<u>USA</u> , France, Germany, UK, Denmark, Sweden, Italy, Spain1, Japan, Norway, Denmark2, Spain2, LatinAmeric, Korea, Legal
	Auto CR	<u>On</u> , Off
	Auto LF	<u>Off</u> , On
	Bit Image	<u>Dark</u> , Light, BarCode
	ZeroChar	<u>0</u> , φ

Table 1-20. Function Setting (2)

Menu	Item	Value
FX Menu	Font	<u>Courier</u> , Prestige, Roman, Sans serif, Script, Orator S, OCR A, OCR B
	Pitch	<u>10cpi</u> , 12cpi, 15cpi, Prop.
	Condensed	<u>Off</u> , On
	T. Margin	0.40 ~ <u>0.50</u> ~ 1.50 ~ inch (0.05 inch increments)
	Text	1 ~ <u>62</u> * ⁸ ~ <u>66</u> * ⁹ ~ available (Max 81) Lines
	CGTable	<u>PcUSA</u> , Italic, PcMultilin, PcPortugue, PcCanFrenc, PcNordic, PcTurkish2, Pclcelandic, PcE. Europe, BpBRASCI, BpAbicom, Roman-8, PcEur88, ISO Latin1, 8859-15 ISO
	Country	<u>USA</u> , France, Germany, UK, Denmark, Sweden, Italy, Spain1, Japan, Norway, Denmark2, Spain2, LatinAmeric
	Auto CR	<u>On</u> , Off
	Auto LF	<u>Off</u> , On
	Bit Image	<u>Dark</u> , Light, BarCode
	ZeroChar	<u>0</u> , ϕ

Table 1-20. Function Setting (2)

Menu	Item	Value
I239X Menu	Font	<u>Courier</u> , Prestige, Gothic, Orator, Script, Presentor, Sans serif
	Pitch	<u>10cpi</u> , 12cpi, 15cpi, 17cpi, 20cpi, 14cpi, Prop.
	Code Page	<u>437</u> , 850, 858, 860, 863, 865
	T. Margin	0.30 ~ <u>0.40</u> ~ 1.50 inch (0.05 inch increments)
	Text	1 ~ <u>63</u> ~ <u>67</u> ~ available (Max 81) Lines
	Auto CR	<u>Off</u> , On
	Auto LF	<u>Off</u> , On
	Auto Graphic	<u>Off</u> , On
	Bit Image	<u>Dark</u> , Light
	ZeroChar	<u>0</u> , ϕ
	CharacterSet	<u>1</u> * ⁸ , <u>2</u> * ⁹

NOTE:

- *1: Not displayed on the panel. Not printed on the status sheet. Not open to users.
- *2: Either is displayed depending on the type of pitch of the selected font. "Pitch" is displayed for the fixed pitch font, and "Height" is for the proportional font.
- *3: Default value is 64 for A4-model controller and 60 for Letter-model controller.
- *4: Appears only in the GLlike mode.
- *5: Appears and can be set only when optional Adobe PS 3 kit is installed.
- *6: Factory default setting for Letter-controller.
- *7: Factory default setting for A4-controller.
- *8: Factory default setting for Letter-controller.
- *9: Factory default setting for A4-controller.
- *10: When "SymSet" value is changed and the font specified by Font Number does not have its Symbol Set, Font Source and Font Number settings are automatically made as follows;

Font Source = Resident, Font Number = 0

Due to this, to print by this symbol set, a font must be selected for which the Font Source and Font Number Value are supported by this symbol set.

1.5.2.1 Setting Items (Model-dependent)

Described below are model-dependent specification details of the setting items for EPL-5800.

MP MODE

When the paper source setting is "Auto" or not specified, MP mode determines the priority of the sources.

Normal: MP > LC (MP Tray has priority)

Last: LC > MP (Lower Cassette has priority)

TRAY ASSIGN

Tray Assign changes the assignment for the paper source select command (ESC&I#H). Effective only for PCL mode.

Table 1-21. Tray Assign

The correspondence of the parameter #	MP	LC	Note
4	1	4	HP Laser Jet 4 compatible
4K	4	1	HP Laser Jet 000/5000/8000 compatible
5S	8	1	HP Laser Jet 5Si compatible

TONER OUT

Specifies the printer operation when "Toner Out" occurs.

- Continue
Printer does not produce "Toner Out" error and continues printing when measurement of Toner counter reaches to the level where "Toner Out" error occurs.
This setting does not influence to "Toner Low" warning.
This parameter is Factory default.
It is recommended to set to Stop when the printer is located at distant place (network printer etc.) and user cannot see its printout soon.

- Stop
"Toner Out" error occurs when the measurement of Toner counter reaches to the level where "Toner Out" error occurs.

PAPER TYPE

Specifies the paper type loaded in the MP Tray.

- Normal: Normal paper
- Thick W: Thick paper
- Thick N: Thick and narrow paper like an envelop.
- Transprnc: OHP sheets

MP TYPE, LC TYPE

Specifies the paper type for MP Tray or LC.

When "Paper Source = Auto", MP Type and LC Type is used to select a unit that matches the paper type specified by the printer driver.

In a printer mode without such command, the same operation as when "Plain" is selected is performed.

"Transpmcy" and "Label" cannot be set to LC Type. Other parameters are common to MP Type.

The following table is the correspondence of "Paper Type" and "MP Type" setting and the printer media

Table 1-22. Paper Type, MP Type, and the Printing Media

Paper Type	MP Type	Printing Media
Normal	OHP	OHP
Normal	Other than OHP	Normal paper
Thick W	Any	Thick paper
Thick N	Any	Postcard/Envelop
Transprnc	Any	OHP

QUANTITY

This is the copy quantity setting when copying by quantity. This setting is specified taking preference over the Copies setting. When the printing quantity is 2 or more, the Copies setting will be 1.

This setting can be specified only with EJL or ESC/Page command and the setting cannot be stored.

If data for 1 job data failed to be stored into printer, the warning "Collate was disabled" will be displayed and the printer prints out only one quantity.

PARALLEL I/F, USB I/F, AUX I/F

Only interfaces that are set to "On" by the panel setting can be used by the automatic selection.

All interfaces are set to "On" at the factory default setting.

When use a fixed interface, set "On" only for the interface that to be used.

Changes to the interface setting will be effective after the Reset All is performed or the power is turned on again.

If "Off" is set to all interfaces, they are reset to "On" after the Reset All is performed or the power is turned on again. (It is not allowed to set "Off" to all interfaces.)

Table 1-23. Interface Settings

	Parallel	USB	Type B	Operations
Using Fixed I/F	○	X	X	Only parallel can be used.
	X	○	X	Only USB can be used
	X	X	○	Only Type B and be used.

Table 1-23. Interface Settings

	Parallel	USB	Type B	Operations
I/F automatic selection	○	○	○	Automatic selection (all interfaces)
	○	○	X	Automatic selection (Parallel and USB)
	○	X	○	Automatic selection (Parallel and Type B)
	X	○	○	Automatic selection (USB and Type B)
Not effective	X	X	X	Returns to the factory default after the Reset All is performed or the power is turned on again.

○: On, X: Off

1.5.3 Printer Messages

Printer messages are Status Message, Error Message, Warning Message, and Service Call Error Message.

Status Message is displayed only when there are no error or during the initialization. No two Status Messages displayed at the same time and Error Message is displayed in the priority order.

Refer to the tables on following pages for each error indication.

Table 1-24. Printer Message

Messages in LCD-Equipped Models	LED Indications						Classification
(When the printer is turned on.)	1. All the LED on. 2. All the LED off. This indicates the printer is checking ROM. 3. Paper LED is turned off, and Toner LED lights on. This indicates the printer is checking RAM. After checking RAM has completed, Toner LED is turned off. Check if the expanded memory is recognized on the status sheet. 4. Memory LED is turned on. This indicates the printer is performing self-check. 5. The printer is now ready to print. During the sequence above, if any service call error has detected, corresponding error message is indicated.						Status
Messages in LCD-Equipped Models	Paper LED	Toner LED	Memory LED	Online LED	Data LED	Continue LED	Classification
Service Req. effff	Refer to 1.6 "Service Call Errors"						Status
System Check	○	○	★	○	○	○	Status
Reset All	●	●	●	●	●	●	Status
Reset	●	●	●	○	○		Status
Exiting Paper Jam	●	○	○	○	○	●	Error
Paper Jam	●	○	○	○	○	●	Error
Feed Jam	●	○	○	○	○	●	Error
Printer Open	●	○	○	○	○	●	Error
Manual Feed ssss tttt	●	○	○	○	○	●	Error
Paper Out sssss tttt	★	○	○	○	○	●	Error
Toner Out	○	●	○	○	○	●	Error
Paper Set sssss tttt	★	○	○	○	○	★	Error
Print Overrun	○	○	●	○	○	★	Error
Mem Overflow	○	○	●	○	○	★	Error
Invalid PS3	○	○	●	○	○	★	Error
Invalid Aux I/F Card	○	○	●	○	○	★	Error
Invalid ROM A	○	○	●	○	○	★	Error

●: On ○: Off ★: Flashing

Table 1-24. Printer Message

Messages in LCD-Equipped Models	Paper LED	Toner LED	Memory LED	Online LED	Data LED	Continue LED	Classification
Writing ROM A	○	○	○	○	● or ★ same as normal data transfer	○	Status
Write Error ROM A	○	○	●	○	○	●	Error
Collate was disabled	○	○	★	○	○	○	Warning
Check Paper Size	★	○	○	○	○	○	Warning
Image Optimum	○	○	★	○	○	○	Warning
Check Paper Type	★	○	○	○	○	○	Warning
Format Error ROM A	No indication (EJL status will be supported)						Warning
Need memory	○	○	★	○	○	○	Warning
Form Feed	○	○	○	○	★	○	Status
Warning Up	○	○	○	●	○	○	Status
Toner Low	○	★	○	○	○	○	Warning
Offline	Online LED goes off						Status
Standby	○	○	○	○	○	○	Status
Ready	○	○	○	● or ★	○	○	Status

●: On ○: Off ★: Flashing

1.6 Service Call Errors

- Explanation
An error generated that cannot be solved by user side.
- LED Condition

All LED on. (0.8 sec) → All LED off (0.2 sec) → Respective LED on specified by error code (0.8 sec) → All LED off (0.2 sec)

This sequence is repeated in 2 sec interval.
Refer to the following Table 1-25 and Table 1-26 for details.
- Solution
Turn off the power and back on.
If an error still remains, see the indicated error code to check and replace the concerning unit.

Table 1-25. Service Call Error (Engine-Related)

Error Code	Explanation	Paper LED	Toner LED	Memory LED	Online LED	Data LED	Continue LED
E0003	Failure in fuser unit	●	○	○	○	○	●
E0004	Failure in main motor	○	●	○	○	○	●
E0005	Failure in fan motor	●	●	○	○	○	●
E0006	Failure in polygon motor	○	○	●	○	○	●
E0007	Failure in HVPS	●	●	●	○	○	●
E0009	Failure in laser-diode	●	○	●	○	○	●
E0014	Engine communication error	○	●	●	○	○	●

●: On ○: Off

Table 1-26. Service Call Error (Controller-Related)

Error Code	Explanation	Paper LED	Toner LED	Memory LED	Online LED	Data LED	Continue Lamp
C0017	CPU Error (Undefined interruption occurred)	○	○	○	●	○	●
C0081	CPU Error (TLB revising exception)	●	○	○	●	○	●
C0082	CPU Error (TLB mistake exception [Load/Fetch])	○	●	○	●	○	●
C0083	CPU Error (TLB mistake exception [Store])	●	●	○	●	○	●
C0084	CPU Error (Address error exception [Load/Fetch])	○	○	●	●	○	●
C0085	CPU Error (Address error exception [Store])	●	○	●	●	○	●
C0086	CPU Error (Bus error exception [Store])	○	●	●	●	○	●
C0087	CPU Error (Bus error exception [Load/Store])	●	●	●	●	○	●
C0088	CPU Error (SYSCALL exception)	○	○	○	○	●	●
C0090	CPU Error (Reservation command exception)	●	○	○	○	●	●
C0091	CPU Error (Coprocessor blank exception)	○	●	○	○	●	●
C0092	CPU Error (FPU exception)	●	●	○	○	●	●
C0093	CPU Error (TLB exception)	○	○	●	○	●	●
C0094	CPU Error (XTLB exception)	●	○	●	○	●	●

Table 1-26. Service Call Error (Controller-Related)

Error Code	Explanation	Paper LED	Toner LED	Memory LED	Online LED	Data LED	Continue Lamp
C0095	CPU Error (Cash exception)	○	●	●	○	●	●
C0096	CPU Error (Trap exception)	●	●	●	○	●	●
C0097	CPU Error (FPU error exception)	○	○	○	●	●	●
C0098	CPU Error (Watch exception)	●	○	○	●	●	●
C0128	CPU Error (Undefined trap)		●	○	●	●	●
C0255	CPU Error (NMI exception)	●	●	○	●	●	●
C0256	CPU Error (Division by 0)	○	○	●	●	●	●
C0257	CPU Error (Arithmetic Overflow)	●	○	●	●	●	●
C0258	CPU Error (Break generated)	○	●	●	●	●	●
C0800	IPL Error (Controller failure)	●	○	○	○	○	○
C1000	Standard RAM error (No RAM at all, etc.)	○	○	●	○	○	○
C1001	Standard RAM error (Not enough for minimum stack, etc.)	●	○	●	○	○	○
C1002	Standard RAM error (Not enough for standard size, etc.)	○	●	●	○	○	○
C1003	Option RAM error	●	●	●	○	○	○
C1100	ROM checksum error (bit0-15)(font)	○	○	○	●	○	○
C1101	ROM checksum error (bit16-31)(font)	●	○	○	●	○	○
C1120	ROM checksum error (bit0-7)(program)	○	●	○	●	○	○
C1121	ROM checksum error (bit8-15)(program)	●	●	○	●	○	○
C1122	ROM checksum error (bit16-23)(program)	○	○	●	●	○	○
C1123	ROM checksum error (bit24-31)(program)	●	○	●	●	○	○
C1170	Option font ROM checksum error	●	○	○	○	●	○
C1180	Option ROM module A checksum error	○	●	○	○	●	○
C1181	Option ROM module B checksum error	●	●	○	○	●	○
C1185	Unsupported ROM module	○	○	●	○	●	○

Table 1-26. Service Call Error (Controller-Related)

Error Code	Explanation	Paper LED	Toner LED	Memory LED	Online LED	Data LED	Continue Lamp
C1190	Cartridge access unable	●	○	●	○	●	○
C1200	EEPROM writing error	○	●	●	○	●	○
C1210	EEPROM writing limit	●	●	●	○	●	○
C1400	Engine initialization error	○	○	○	●	●	○
C1999	Other hardware error	○	●	●	●	●	○
C2000	Software error	●	●	●	●	●	○

●: On ○: Off

1.7 Special Operation

The function described below are activated by holding the specified switches down when turning the printer on.

Table 1-27. Special Operation

Function	Key
Hex Dump	Form Feed
Toner reset	On Line + Form Feed
Photoconductor life reset	On Line + Continue
EEPROM initialization	On Line + Continue + Alt
Panel setting value initialization	Continue
Update program ROM	On Line + Form Feed + Continue + Alt

HEX DUMP

All print data are printed in ASCII hexadecimal value. Any interface equipped with the printer is valid for receiving the data in this mode. The following information is printed.

- A list of received data converted in ASCII hexadecimal value.
(Non-readable code is printed as ".")
- Page number

TONER RESET

Performing this operation initialize the toner counter value to "E■■■■F".

PHOTOCONDUCTOR LIFE RESET

Performing this operation initialize the photoconductor unit life counter to "100%".

EEPROM INITIALIZATION

This operation clears the contents of EEPROM with "00H" and set the factory default parameters.



Note that this operation clears all setting information and a total print counter value as well.

PANEL SETTING VALUE INITIALIZATION

This operation initialize all setting information of common functional environment and I/F specific functional environment and set the factory default values.

UPDATE PROGRAM ROM

This operation activates the Code ROM-DIMM update function.

1. By executing the operation, the printer starts normal power-on sequence. Keep depressed all buttons until "Paper", "Toner" and "Memory" LEDs are turned on after completing RAM check.
2. Next, release all the buttons and "Online" LED starts blinking and all other LEDs are turned on. Approx. 3 seconds later, "Continue" and "Form Feed" LEDs are turned off and this indicates that the printer is ready to receive the firmware data via parallel I/F.
3. After completing update, "Online" LED is blinking and all other LEDs are turned off.

1.8 Notes for Operation

1.8.1 Expansion RAM

When EPL-5800 runs out of memory, the Memory LED flashes or lights. (Corresponds to “Mem Overflow”, “Image Optimum”, “Need Memory” or “Collate was disabled” on the machines with LCD.)

In this case, any of the following measures may be taken;

- Reducing the resolution.
- Select “Halftone” when using Enhanced MicroGray.
- Reducing the receiving buffer size to “Minimum”.
- Use only one interface and set “Off” for other interfaces.

The only way to definitely avoid memory shortages is to install more memory.

(Commercially available SDRAM DIMMs for PCs: 168 pins, 64-bit with SPD)

1.8.2 Powering Off

EPL-5800 includes an internal non-volatile memory (EEPROM).

If the printer is powered off during the process of writing to non-volatile memory, the writing operation to the non-volatile memory cannot be guaranteed. And therefore the next time the printer is powered on or the “Reset All” is carried out, panel settings may be initialized or a service call error may occur.

The non-volatile memory saves the function settings, and the following cases are those in which the memory is rewritten, and therefore the printer should not be powered off;

- After the printer is powered on, until the OnLine LED lights.
- While the printer is printing.
(While the paper feed motor is operating.)
- While the Data LED is flashing or lights.
To stop the printer, either put it off line or carry out a Reset.

1.8.3 High-Temperature Components

The fuser unit inside the printer becomes hot, and therefore care must be taken not to touch the fuser unit while opening the printer to clear a paper jam.

CHAPTER

2

OPERATING PRINCIPLES

2.1 Operating Principles of Mechanism

2.1.1 Paper Path

The following figure shows the major paper paths in the printer. EPSON EPL-5800 has two paper feed methods as standard; multi paper feed tray (150 sheets) and manual feed (1 sheet). With the optional second paper feed unit (500 sheets), EPSON EPL-5800 has three paper feed methods. Paper once fed by the paper feed roller is carried through transfer roller → fusing roller → paper exit roller and ejected to paper eject tray.

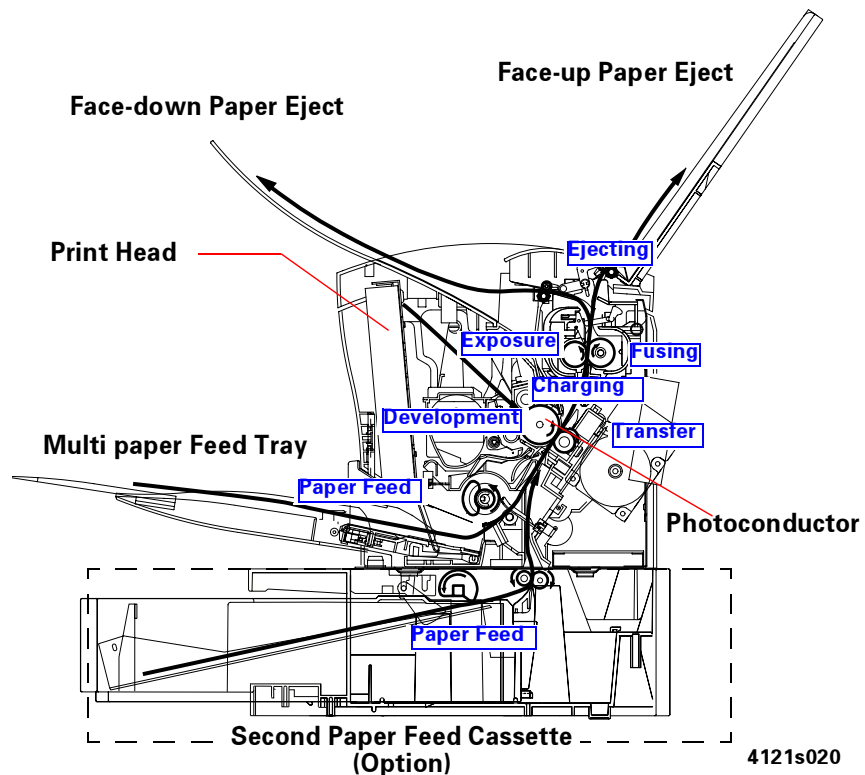

Figure 2-1. Paper Path

2.1.2 Paper Feed Mechanism

Multi Paper Feed Tray

- When the paper feed solenoid (SL1) is turned ON, the driving power from the main motor (M1) is transmitted to the paper feed roller via the paper feed clutch (one-way clutch), and the paper feed roller rotates.
- At the same time, the push down cam rotates, and it lifts the tray lifting plate. Paper on the tray is carried into the printer by the paper feed roller.
- Separation pad method is used in order to separate each paper and prevent feeding the second paper together.
- Since there is no paper size sensor mechanism in the multi paper feed tray, the printer detects the length of paper by the ON period of paper feed sensor (PS1), and judges the paper size. So, if the paper has the same length, the printer judges the paper as the same size even its width is different.

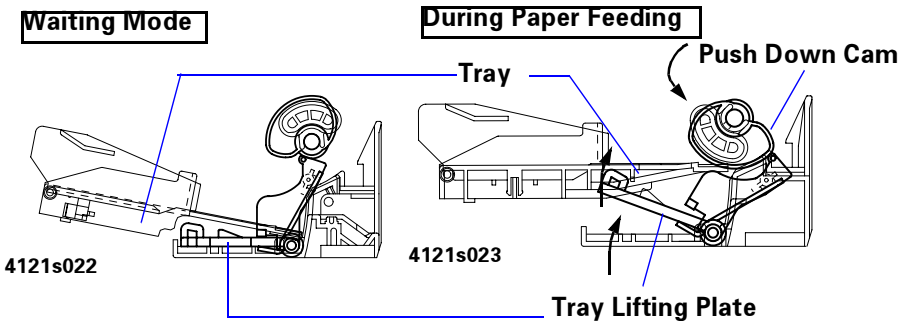
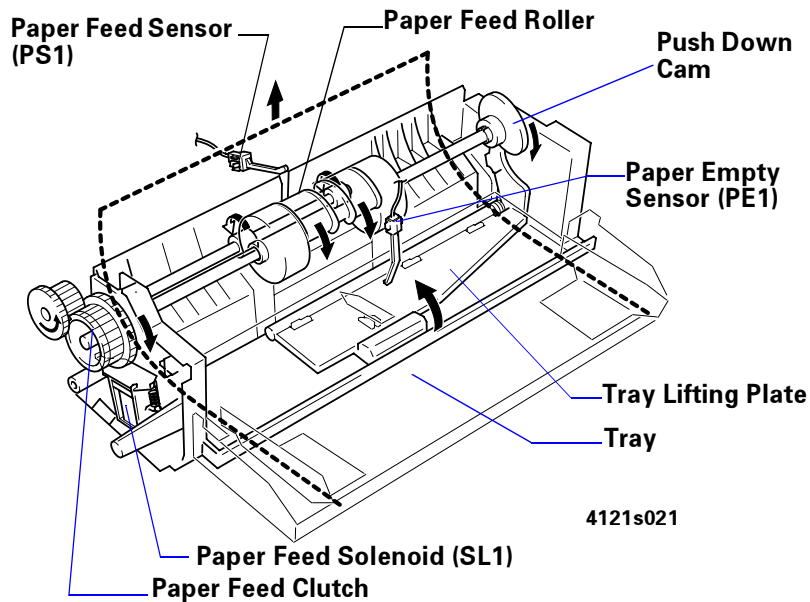

Figure 2-2. Paper Feed Operation

PAPER EMPTY SENSOR

Paper empty sensor (PE1) is mounted on the upper part of the multi paper feed tray and it detects paper empty on the multi paper tray.

When there is paper on the tray, the actuator stands up and the sensor is turned OFF.
 When paper on the tray went out, the actuator falls into the hole of the tray and the sensor is turned ON.

2.1.2.1 Second Paper Feed Unit (Option)

MECHANISM

- Since the second paper feed unit does not have driven motor, driving power for feeding paper and carrying paper (driving force from M1) is transmitted to the second paper feed unit from the printer via the connecting gear. Paper feed method is the same as for multi paper feed tray.
- As separation method, the separation pad method is used for the multi paper feed tray, but the separator claw is used for the second paper feed unit.
- The separator claw is the method that uses elasticity between the separator installed at the paper fed cassette and the paper. Only one sheet of paper is fed by one paper feed operation.
- The paper feed solenoid (SL21) is controlled from the printer side via the relay board (PWB-A) of the second paper feed unit.

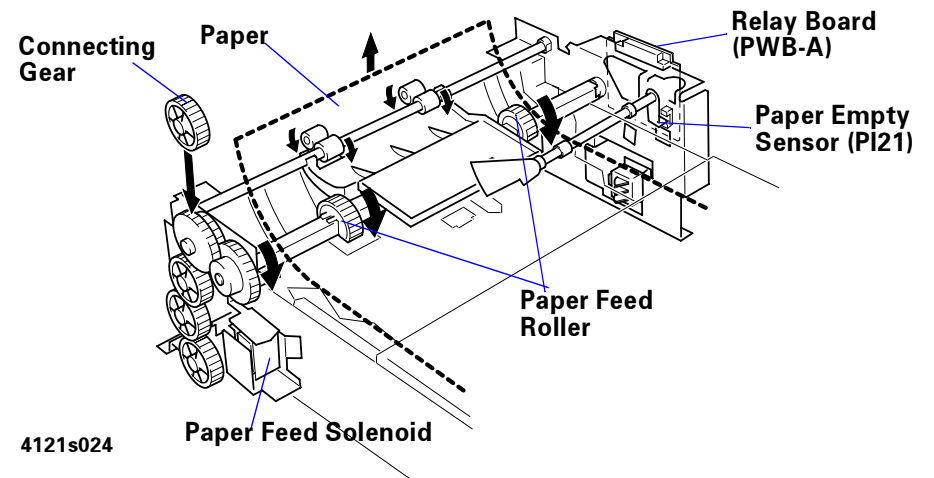

Figure 2-3. Second Paper Feed Unit Mechanism

PAPER EMPTY SENSOR

Paper empty sensor (PI21) is mounted on the relay board (PWB-A) of the second paper feed unit and it detects paper empty in the second paper feed cassette.

When there is paper on the tray, the actuator stands up and the sensor becomes OFF.

When paper on the tray went out, the actuator falls into the hole of the tray lifting board and the sensor becomes ON.

CASSETTE TYPE SENSOR

Cassette type sensor switch (SW21) with sector-shaped lever is mounted on the second paper feed unit.

When the cassette for each paper size is inserted, the switch presser on the right side of each cassette pushes the lever according to the paper size and it turns the cassette type sensor ON.

This switch is the three-consecutive switch, and the printer distinguishes the cassette type (paper size) by ON/OFF combination of three switches.

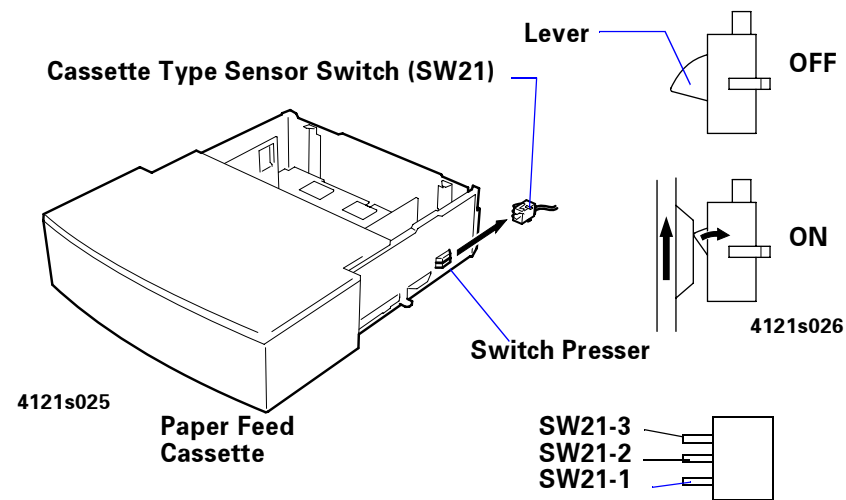

Figure 2-4. Cassette Type Sensor Mechanism

Table 2-1. ON/OFF of SW21 on each cassette type

Cassette Type	SW21-1	SW21-2	SW21-3
A4	OFF	OFF	ON
B5	ON	ON	OFF
Letter	OFF	ON	OFF
Executive	OFF	ON	ON
No cassette or cassette is not specified	OFF	OFF	OFF
	ON	ON	ON
	ON	OFF	ON

2.1.3 Charging Process

2.1.3.1 Overview

- It is charged by giving static electricity to OPC drum (Organic Photoconductor) before laser exposure.
- Surface of OPC drum is charged by rotating brush (charging brush) and pre-charging film.
- Charging by the rotation brush (charging brush) and the pre-charging film has low rate of ozone occurrence by corona discharge and also low voltage and excels in homogeneity and stability of the electric potential because of direct charging to the OPC drum.
- Electric potential on the surface of OPC drum after charging is about -800V.
- A rotation brush (charging brush) rotates when drive from the main motor (M1) is transmitted to the gear of the rotation brush (charging brush).
- Pre-charging film takes a pre-charge before the rotation brush (charging brush) takes a charge in order to improve efficiency of charging.

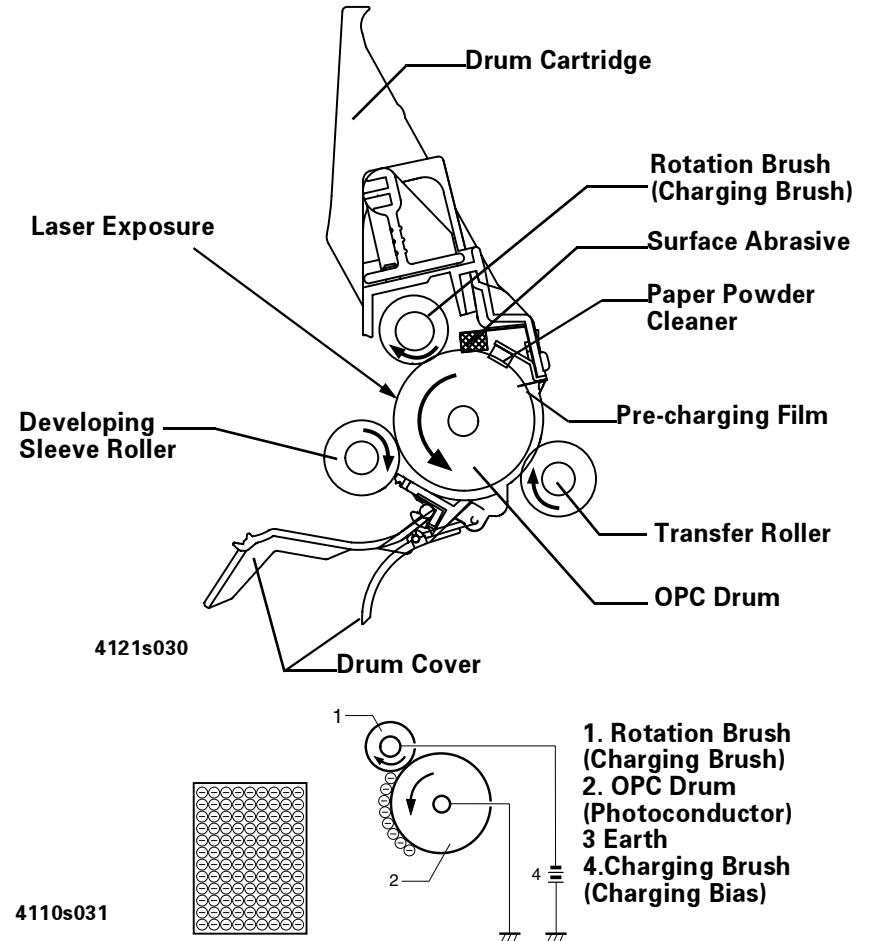

Figure 2-5. Charging Mechanism

2.1.4 Exposure Process

The laser beam from the print head creates an electrostatic latent image on the OPC drum surface.

The following control is performed in order to find appropriate timing to print the image.

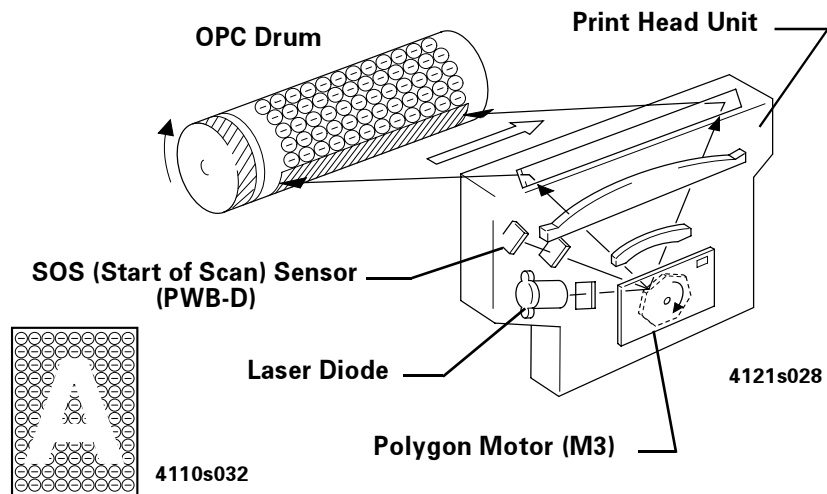

Figure 2-6. Exposure Mechanism

SUB SCANNING DIRECTION (VERTICAL SCANNING DIRECTION)

- When the printer receives the PRINT signal, the polygon motor (M3) and the main motor (M1) rotate, and the main motor (M1) starts the paper feeding operation.
- When the specified period of time passes after the end of fed paper turns the paper feed sensor ON (TOD signal), the main control board sends the VIDEO signal to the print head, and printing starts.
- When moving on from the first line to the second line, the print starting position is shifted down by delaying the VIDEO signal sending time.

MAIN SCANNING DIRECTION (HORIZONTAL SCANNING DIRECTION)

- To unify the laser exposure timing emitted every one line of main scanning, the SOS sensor is mounted on the laser diode control board (PWB-D).

2.1.4.1 Printable area

- The main control board sends the VIDEO signal, which corresponds to the paper size, to the engine (controller).
- The main control board determines the printing start position by TOD signal (sub scanning direction) and the HSYNC signal sent by the engine (controller).
- The print head starts laser exposure when it receives the VIDEO signal.

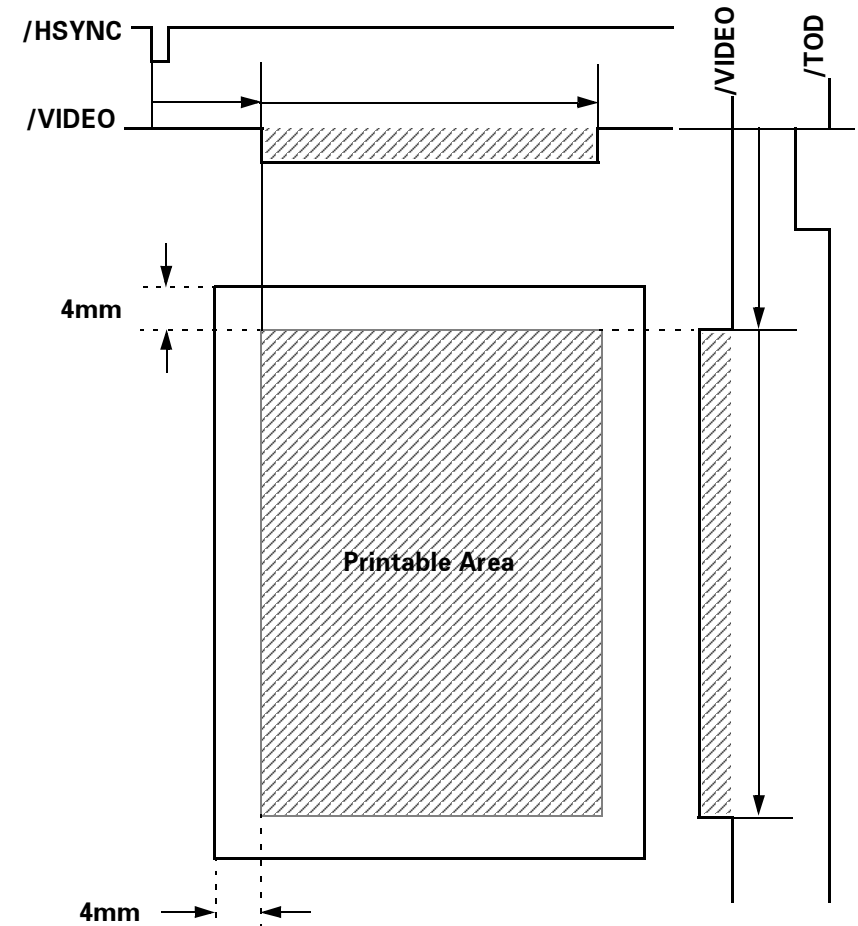

Figure 2-7. Printable Area

2.1.5 Development Process

2.1.5.1 Overview

Putting toner on the static latent image on the OPC drum makes the toner image.

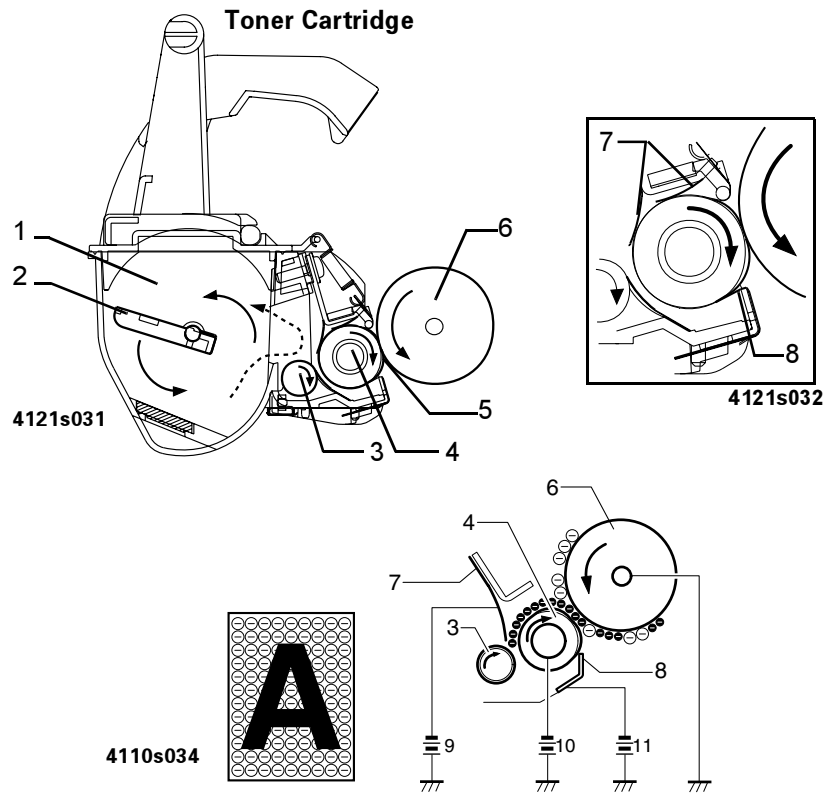

Figure 2-8. Developing Mechanism

0992s24

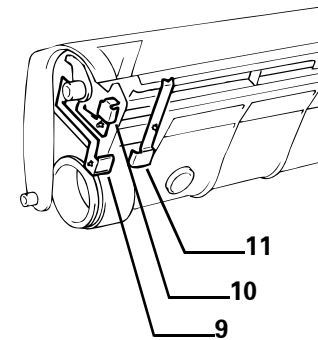

Figure 2-9. Bias Terminals

Table 2-2. Parts of Developing Mechanism

No.	Name	Function
1	Toner hopper	Toner is in.
2	Toner agitation wing	Agitates the toner hopper inside and sends toner to the toner sending roller.
3	Toner sending roller	Transfers toner to the sleeve roller.
4	Sleeve roller	Rotates the resin sleeve.
5	Resin sleeve	Transfers toner to the surface of the OPC drum surface.
6	Photoconductor (OPC drum)	Creates the latent image on the surface by the laser beam. Develops the image by the resin sleeve and carries the developed image to the paper surface. Gives toner a negative charge by letting toner through between the toner blade and the resin sleeve.
7	Toner blade	Puts toner thin and even on the resin sleeve.
8	Bias seal	Collect toner which did not stick to the OPC drum

Table 2-2. Parts of Developing Mechanism

No.	Name	Function
9	Development blade voltage terminal (V_{BL})	DC-590V
10	Development voltage terminal (V_B)	DC-340V
11	Under development seal terminal (V_{SS})	DC-340V

2.1.6 Transfer Process

2.1.6.1 Overview

- During the image transfer process the image created on the OPC drum in the development process is transferred to the paper.
- Transfer method is not the corona transfer but the roller transfer method by the transfer roller.
- Roller transfer method has low rate of ozone occurrence by corona discharge, and chances for dislocating the transferred image is very small because the paper passes between the drum and the transfer roller all through during printing.
- The reversed bias is charged on the transfer roller when cleaning the transfer roller before printing.
- Leftover electric potential on the paper is removed by the discharge needle.

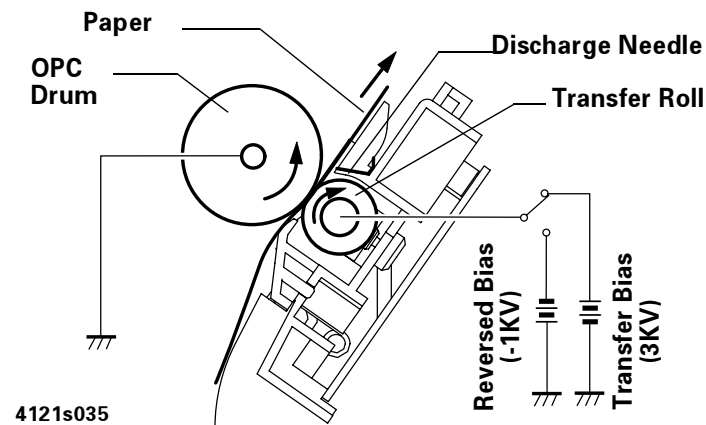
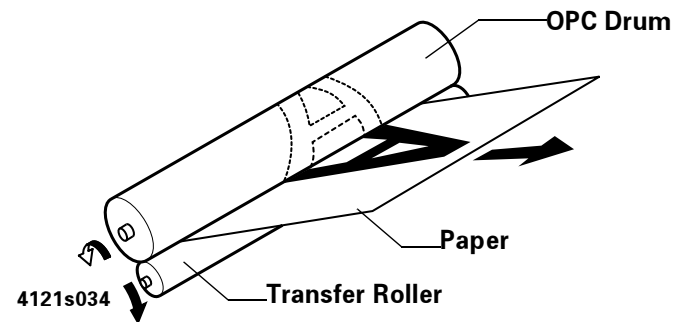

Figure 2-10. Transfer Mechanism

2.1.7 Fusing Process

2.1.7.1 Overview

- In this process, toner which is transferred to the paper in the transfer process is fused to the paper.
- Fusing system this printer uses is the heat roller fusing system. The toner passes between the back-up roller and the heat roller, which is heated up by the heater lamp, and heat and pressure are applied to permanently fuse the toner to the paper.

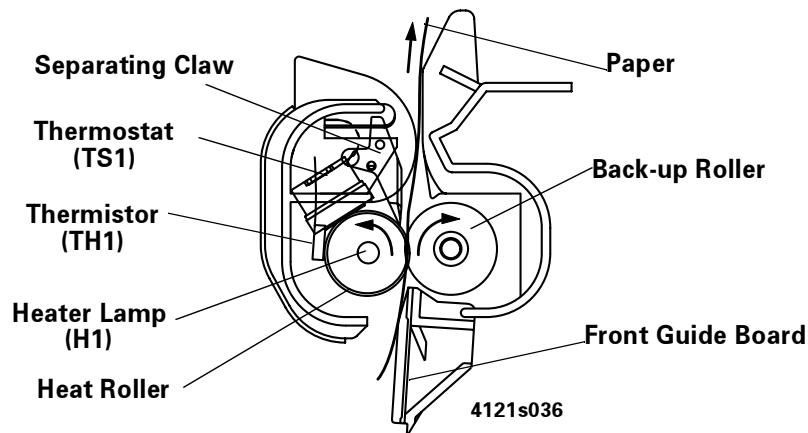

Figure 2-11. Fusing Mechanism

2.1.7.2 Fusing Temperature Control Circuit

- The thermistor (TH1) detects the surface temperature of the fusing heat roller and inputs the analog voltage to IC1A-78. Based on the thermistor detected temperature, the heater lamp (H1) is turned ON (light on) and OFF (light off) by the heater lamp ON/OFF signal which is output by the IC1A-55, and controls the temperature of the fusing components.
- When the heater lamp is not turned OFF even though the thermistor detects abnormal high temperature (when the surface temperature of the fusing heat roller exceeds 210°C), the output from IC-79 is changed from L to H and it forcibly turns the heater lamp OFF.

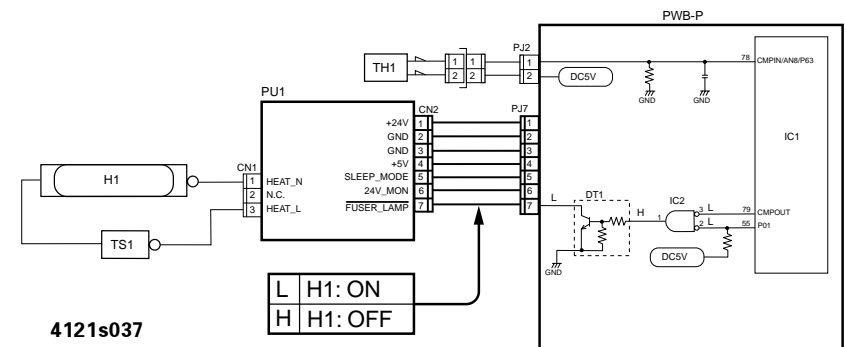

Figure 2-12. Fusing Temperature Control Circuit

AT 600DPI

When the power switch is turned ON, the printer performs initialization, warm-up starts, and the heater lamp is turned on. Then, the following temperature controls are performed.

- Temperature control mode 1
This mode controls temperature during printing as 195°C and temperature in standby as 115°C.
After this mode continues for 90 seconds, it shifts to the mode 2.
- Temperature control mode 2
After this mode continues for 208 seconds, it shifts to the mode 3.
Printing temperature of the fusing roller is gradually lowered from 195°C to 185°C.
- Temperature control mode 3
Controls temperature during printing as 150°C and temperature in standby as 115°C.
Unless any errors generated or open the upper cover, this mode is sustained.

AT 1200DPI

When the power switch is turned ON, the printer performs initialization, warm-up starts, and the heater lamp is turned on. The heater lamp stays ON until the temperature of the hear roller reaches about 155°C. Then, the following temperature controls are performed.

- Temperature control mode 1
Controls temperature during printing as 155°C and temperature in standby as 115°C.
After this mode continues for 45 seconds, it shifts to the mode 2.
- Temperature control mode 2
After this mode continues for 208 seconds, it shifts to the mode 3.
Printing temperature of the fusing roller is gradually lowered from 155°C to 150°C.

- Temperature control mode 3
Controls temperature during printing as 150°C and in standby as 115°C.
Unless any errors generated or open the upper cover, this mode is sustained.

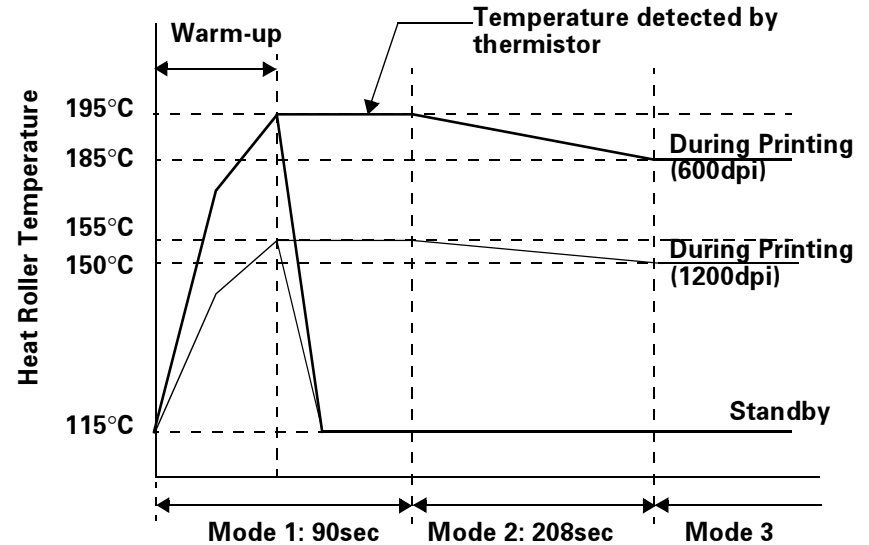

Figure 2-13. Heat Roller Temperature Control

Table 2-3. Heat Roller Temperature Control

Condition before temperature control is aborted	Temperature just after temperature control started		
	Less than 50°C	50°C or over less than 115°C	115°C or over
Mode 1, during the warm-up	Mode 1		
Mode 2, 3, or when the power supply OFF	Mode 1	Mode 2	Mode 3

2.1.8 Paper Eject Process

2.1.8.1 Face up / Face down Switching Function

After fusing process, paper is ejected either face up or face down by the face up / face down switching function.

Manual operation of the paper eject switching lever gears the tray switching guide inside the printer, and the paper path either to the face up eject or to the face down eject is switched.

The paper eject switching lever is located at the paper eject.

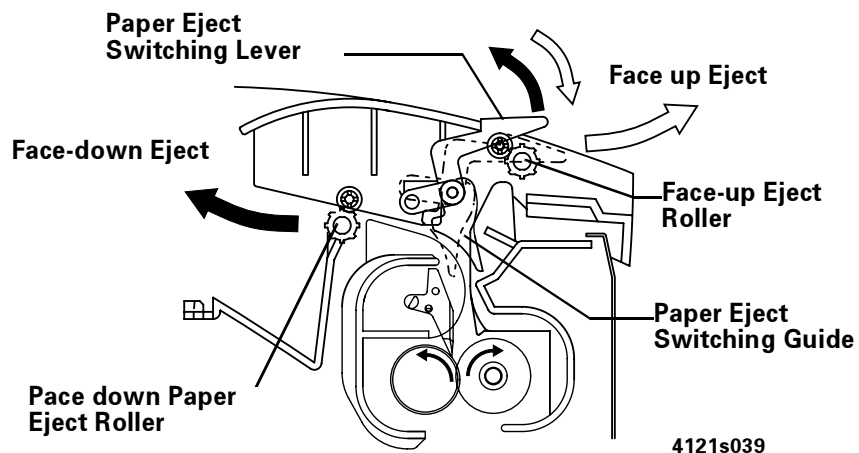

Figure 2-14. Paper Eject Mechanism

FACE DOWN EJECT

Paper is ejected to the face down tray which is located on the top of the printer.

FACE UP EJECT

Paper is ejected to the optional face up tray.
Face up eject is available even without optional face up tray.

Table 2-4. Capacity of the Trays

Capacity on each tray	
Face down tray	100 sheets
Face up tray	20 sheets

CHAPTER

3

TROUBLESHOOTING

3.1 Troubleshooting

This section describes the basic procedure for checking the printer operation that allows you to find out troubles and necessary repair service easily.

3.1.1 Troubleshooting for Paper Jam

The printer checks if there is paper in the printer or not by detecting the signals from the paper feed sensor (PS1) and the paper eject sensor (PS3). Paper jam during paper passing is detected by rise and fall of signals from PS1 and PS3.

When paper jam is detected, all the drive is turned OFF (except for the following cases).

- Continuous Printing
When detecting case 1 in "Paper Jam Conditions", and if there is carrying paper in the printer, the printer turns all the drive OFF after ejecting the carrying paper.
- Single Printing
When detecting only case 1 in "Paper Jam Conditions", since there is no paper in the fusing unit, the printer does not turn the heater lamp (H1) OFF, but turns the other drive OFF.

PAPER JAM CONDITIONS

1. The paper feed sensor (PS1) is not turned ON
 - within about 2.1 seconds (at 1200dpi: within about 13.58 sec) after the multi paper feed tray starts feeding paper (in other words, the paper feed roller starts rotating by turning the paper feed solenoid ON).
 - within about 2.35 seconds (at 1200dpi: within about 4.7 sec) after the second paper feed unit starts feeding paper.
2. The paper feed sensor (PS1) is not turned OFF within about 6.79 seconds (at 1200dpi: within about 13.58 sec) after the top edge of paper reaches the paper feed sensor (PS1) (PS1:ON).
3. The paper eject sensor (PS 3) is not turned ON within about 2.3~3.08 seconds (at 1200dpi: within about 4.6~6.16 sec) after the top edge of paper reaches the paper feed sensor (PS1) (PS1:ON).

4. The paper eject sensor (PS 3) is not turned OFF within about 2.05~2.82 seconds (at 1200dpi: within about 4.1~5.64 sec) after the bottom edge of paper passes by the paper feed sensor (PS1) (PS1:OFF).
5. The paper feed sensor (PS1) is ON when the power ON/OFF switch (S1) is ON or when the cover is closed.
6. The paper eject sensor (PS3) is ON when the power ON/OFF switch (S1) is ON or when the top cover is closed.

RESETTING THE PAPER JAM

After the paper jam is cleared, the error is canceled by closing the top cover.

3.1.1.1 Check Point

The table below lists the check-point for identifying possible cause of paper jam occurred with different timing.

PAPER JAM WHEN THE POWER IS ON

Table 3-1. Troubleshooting for the Paper Jam (1)

Check Item		Remedy
Is there any paper left?	→ Yes	Remove all the paper in the printer.
↓No		
Does the lever of the paper eject sensor (PS3) operate normally?	→ No	Check the lever operation.
↓Yes		
Does the lever of the paper feed sensor (PS1) and the second paper feed sensor (PS21) work right?	→ No	Check the lever operation.
	→ Yes	Replace PS1 or PS21. Replace PS3. Replace the main control board.

PAPER JAM FROM THE PAPER FEED TO THE TRANSPORT

Table 3-2. Troubleshooting for the Paper Jam (2)

Check Item		Remedy
Do the paper feed roller and the second paper feed roller rotate?	→ No	Replace the paper feed solenoid (SL1). Replace the second paper feed solenoid (SL21).
↓Yes		
Is recommended paper used?	→ No	Ask the user to use the recommended paper.
↓Yes		
Is paper bent, wrinkle, or wet?	→ Yes	Replace the paper and tell the user how to keep paper.
↓No		

Table 3-2. Troubleshooting for the Paper Jam (2)

Check Item		Remedy
Is the paper feed roller deformed? Or is it worn out by friction or is there any dirt?	→ Yes	Replace the paper feed roller. Replace the second paper feed roller.
	↓No	
Does the lever of the paper feed sensor (PS1) operate normally?	→ No	Check the lever operation.
	→ Yes	Replace PS1. Replace the main control board.

PAPER JAM FROM THE TRANSPORT TO THE PAPER EJECT

Table 3-3. Troubleshooting for the Paper Jam (3)

Check Item		Remedy
Is the transfer roller deformed? Or is it worn out by friction or is there any dirt? (the life end of the transfer roller)	→ Yes	Replace the Transfer roller.
	↓No	
Is the fusing roller deformed? Or is it worn out by friction or is there any dirt?	→ Yes	Replace the fusing unit.
	↓No	
Does the paper eject roller rotate?	→ No	Replace the top cover assembly.
↓Yes		
Does the lever of the paper eject sensor (PS3) operate normally?	→ No	Check the lever operation.
	→ Yes	Replace the fusing unit or PS3. Replace the main control board.

3.1.2 Troubleshooting for Abnormal Operations

If the following errors are detected by a built-in diagnostic function, all the drive is turned OFF and the hardware error is indicated on the control panel.

ABNORMAL LASER

1. Right after the polygon motor starts rotating, the laser diode is forced to emit lights and the laser power is adjusted.
While the laser power adjusted, if the adjustment signal (DA1, DA2) goes out of rated value, it is detected as abnormal laser.

ABNORMAL POLYGON MOTOR

This error is detected in the following cases;

1. /SSCAN signal is not detected even once within 0.8 seconds after the polygon motor is turned ON.
2. The rotation number of polygon motor does not settle within $\pm 0.5\%$ within 6.0 seconds after the polygon motor is turned ON.
3. After the polygon motor is turned ON and the rotation number of polygon motor settled within $\pm 0.5\%$, the rotation number goes beyond $\pm 3\%$ for more than 5.5 seconds continuously.

ABNORMAL MAIN MOTOR

This error is detected in the following cases;

1. Motor lock signal is not detected within 1.0sec after the main motor is turned ON.
2. Motor lock signal is turned OFF for 0.1 sec continuously.

ABNORMAL FAN MOTOR

This error is detected in the following case;

1. Motor lock signal is detected as "H" for 2.0 sec continuously after the fan motor is turned ON. (At normal rotation, the motor lock signal indicates "L")

ABNORMAL FUSING

1. If in any condition the thermistor detects that the temperature exceeds 220°C for 50msec, it determines as fusing abnormal high temperature.
2. The temperature detected by the thermistor from 8 to 12 seconds after warming-up and the temperature detected by the thermistor when warming-up starts are compared, and if it is detected that the temperature detected by the thermistor is below the standard value for 50msec, it determines the thermistor is in trouble.
(This detection applies only when the temperature detected by the thermistor is below 80°C.)
3. If the temperature detected by the thermistor does not reach the setting temperature within 45 seconds after warming-up starts, it determines as fusing abnormal rising.
4. When controlling the temperature, if the temperature detected by the thermistor goes below the setting temperature for 50msec continuously, it determines as fusing abnormal low temperature.
Setting temperature is 140°C (600dpi) or 110°C (1200dpi) on the printing mode and 70°C on the waiting mode.

3.1.2.1 Check Point

The table below lists the check-point for identifying the possible cause and a remedy for each error detected by the printer.

ABNORMAL LASER

Table 3-4. Troubleshooting for Abnormal Laser

Cause	Remedy
Abnormal laser diode	Replace the print head unit. Replace the main control board.

ABNORMAL POLYGON MOTOR

Table 3-5. Troubleshooting for Abnormal Polygon Motor

Cause	Remedy
Abnormal Polygon Motor	Replace the print head unit. Replace the main control board.

ABNORMAL MAIN MOTOR

Table 3-6. Troubleshooting for Abnormal Main Motor

Check Item	Remedy
Main Motor (M1) does not rotate.	Replace the main motor (M1). Replace the main control board.

ABNORMAL FAN MOTOR

Table 3-7. Troubleshooting for Abnormal Fan Motor

Check Item	Remedy
Cooling Fan Motor (M2) does not rotate.	Replace the cooling fan motor (M2). Replace the main control board.

ABNORMAL FUSING

Table 3-8. Troubleshooting for the Abnormal Fusing

Check Item		Remedy
Is the fusing unit warmed-up?	→ Yes	Replace the thermistor (TH1) or the fusing unit. Replace the main control board. Replace the power unit (PU1).
↓No		
Is there continuity between Pin 1 and Pin 3 of the connector of the fusing unit?	→ No	Replace the fusing unit. Replace the heater lamp (H1) or the thermostat (TS1).
	→ Yes	Replace the power unit (PU1) or the main control board.

POWER CANNOT BE TURNED ON

Table 3-9. Power Cannot be Turned ON

Check Item		Remedy
Is the power code plugged in?	→ No	Connect the power code to the plug.
↓Yes		
Is the power code connected to the printer body?	→ No	Connect the power code to the printer.
↓Yes		
Is the power switch (S1) ON?	→ No	Turn the power switch ON.
↓Yes		
Is the interlock switch (S2) ON?	→ No	Adjust the position of the interlock switch (S2).
↓Yes		
Is the fuse (F1 or F2) in the power unit PU1 disconnected?	→ No	Replace the PU1 or the main control board.
	→ Yes	Replace the fuse (F1 or F2).

3.1.3 Troubleshooting for Print Quality Problems

When the print quality problems occur, replace the toner cartridge and the drum cartridge first, and determine either it is caused by each cartridge or caused by the printer.

When it is a print quality problem, measure the generating pitch for abnormal images, and specify the abnormal part with the table below.

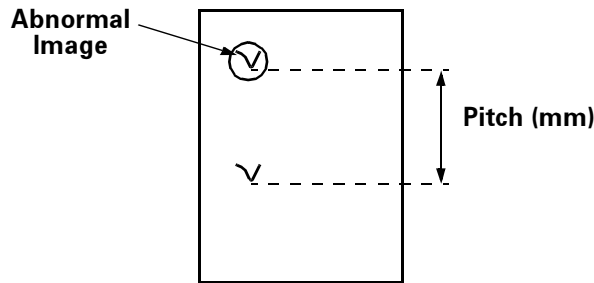

Figure 3-1. Print Image

Table 3-10. Print Quality Problems 1

Pitch	Possible Abnormal Part (Diameter)	Replacement Unit
28mm	Sleeve Roller (φ15.7mm)	Toner Cartridge
94.2mm	OPC Drum (φ 30mm)	Drum Cartridge
50.3mm	Transfer Roller (φ 16mm)	Transfer Roller
62.8mm	Heat Roller (φ 20mm)	Fusing Unit
67.8mm	Backup Roller (φ 21.6mm)	

Table 3-11. Print Quality Problems 2

Symptom	Possible Cause	Solution
All White 0951o211	No toner cartridge.	Install the toner cartridge.
	No toner in the toner cartridge.	Replace the toner cartridge.
	No drum cartridge.	Install the drum cartridge
	Defective OPC drum.	Replace the OPC drum.
	Abnormal laser emission.	Replace the print head. Replace the high voltage unit (HV1). Replace the main control board.
All Black 0951o213	Abnormal laser emission.	Replace the print head. Replace the main control board.
	Abnormal charging.	Replace the high voltage unit (HV1). Replace the main control board.
White Out 0951o220	Paper is wet.	Replace paper.
	Improper transfer.	Replace the transfer roller. Replace the high voltage unit (HV1). Replace the main control board.

Table 3-11. Print Quality Problems 2

Symptom	Possible Cause	Solution
Back of paper gets dirty. 	Fusing roller is dirty.	Replace the fusing unit (fusing roller).
	Transfer roller is dirty.	Replace the transfer roller.
	Paper path is dirty.	Clean the paper path.
Low image density. 	No toner in the toner cartridge.	Replace the toner cartridge.
	OPC drum is at the end of life.	Replace the drum cartridge.
	Defective developing bias.	Replace the high voltage unit (HV1). Replace the main control board.
Foggy background. 	Defective developing bias.	Replace the high voltage unit (HV1). Replace the main control board.
	OPC drum is at the end of life.	Replace the drum cartridge.

Table 3-11. Print Quality Problems 2

Symptom	Possible Cause	Solution
White line. Black line. 	There is scar or damage on the OPC drum.	Replace the OPC drum.
	Defective print head.	Replace the print head. Replace the main control board.
Offset image. 	Defective fusing roller.	Replace the fusing unit (fusing roller).
	Defective transfer roller.	Replace the transfer roller.

CHAPTER

4

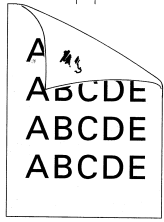
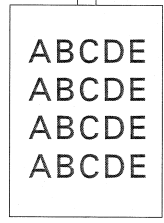
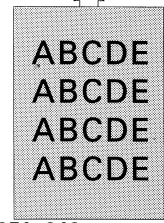
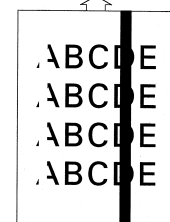
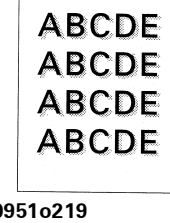
DISASSEMBLY AND ASSEMBLY

4.1 Overview

4.1.1 Precaution for Disassembly and Assembly

Read following caution and warning carefully before starting disassembly and assembly.

4.1.1.1 Precaution at Maintenance and Disassembling



- Be sure to plug off the power cable before disassembling.
- Unless specially mentioned, reverse the disassembling procedure for assembling procedure.
- If you need to drive the machine with the cover off, be careful not to pinch hands or clothes in the operating or rotating parts (gears, rollers, motors, etc.).
- Never touch any terminals of electric components or high voltage components (power supply unit, high voltage unit, etc.).
- Do not touch the fusing unit right after turning the printer off, since the unit remains hot for a while after turning the power OFF. Disassemble after the fusing unit is enough cooled.
- When inserting or removing connectors, make sure the power supply is OFF. When electricity is turned on, do not remove any connectors.
When inserting or removing a connectors, be sure to do so holding the connector housing.
Never insert or remove connectors holding the wiring cord; it may result in a loose connection.
- Use the specified rated fuses.
- In order to ensure the electric conduction, install the earth wire and the earth plate correctly and firmly.
After removing the out-teethed washers, make sure to re-install them. Do not replace them with other kind of screws or washers.

4.1.1.2 Precaution at Handling the Laser Mechanism



- Be sure to disconnect the power supply when working on the laser path around the print head or around the OPC drum.
- Putting the highly reflective tools into the laser path is dangerous. Be careful to handle these tools especially at the user's place.
- If you cannot turn off the power supply because the service requires power, remove watches and rings and wear laser protective goggles.
Use goggles that meet the following specification.
Maximum power: 0.6mW
Output wavelength: 770-810nm

4.1.1.3 Handling Forbidden



- Never remove, disassemble, nor adjust the following parts.
 - Print head unit
 - Any parts where the installing screws painted red

4.1.1.4 Precaution at Handling the Print Board

Handling the print board needs the following precautions.

PRECAUTION AT TRANSPORTING AND KEEPING



- For transporting and keeping, keep the printer in the conductive case or the conductive mat, and do not take off unless necessary.
(Do not use vinyl sack or paper to pack the printer.)
- Avoid direct sunlight when keeping the printer.
- Do not put the printer on places easily charged with static electricity (on a carpet, etc.) or products (plastic, vinyl sack, etc.).

PRECAUTION AT REPLACING

CAUTION

- Basic replacement = unit or assembly replacement
- When removing connectors from the print board, be sure to unplug the power supply in advance.
- When taking the print board out of the conductive sack or conductive case, or when replacing the print board, be sure to handle it with the edge of the board and avoid touching IC terminals and patterns.

PRECAUTION AT CHECKING

CAUTION

- Avoid direct IC check by the tester. Determine OK/NG by checking the connector on the board.
- Be sure to avoid any short between IC terminals caused by metallic tools.
- If touching the elements on the board is unavoidable, be sure to perform body earth.

4.1.1.5 Precaution at Handling the Photoconductor (Drum Cartridge)

PRECAUTION AT TRANSPORTING AND KEEPING

CAUTION

- For transporting and keeping, be sure to use specified boxes.
- When keeping the printer, avoid direct sunlight and keep temperature between -20°C ~40°C.

PRECAUTION AT HANDLING

CAUTION

- The OPC Drum is very sensitive to light and the recovery of sensitivity takes time; do not open the protection cover or do not expose to the sunlight for a long period.
- Do not put fingerprints, oil, or chemicals on the surface of the OPC Drum.
- Do not scratch the surface of OPC Drum.

4.1.2 Regularly Replacement Parts

Table 4-1. Regularly Replacement Parts

Parts Name	Cleaning Cycle	Replacement Cycle (Continuous Printing)	Replacement Cycle (Intermittent Printing)
Drum Cartridge	None	About 20,000 sheets	About 16,000 sheets
Toner Cartridge (Supplied by a consumer)	None	About 6,000 sheets	About 4,800 sheets
Toner Cartridge (Packaged)	None	About 3,000 sheets	About 2,400 sheets
Transfer Roller (A and C environment in the Figure 4-1)	None	About 135,000 sheets	About 80,000 sheets
Transfer Roller (B environment in the Figure 4-1)	None	About 100,000 sheets	About 50,000 sheets
Fusing Unit	None	About 50,000 sheets	
Paper feed roller	When paper feed trouble is happened.	Replace when trouble is happened.	
Second paper feed unit paper feed roller			

NOTE: Drum cartridge and toner cartridge are basically to be replaced by users.

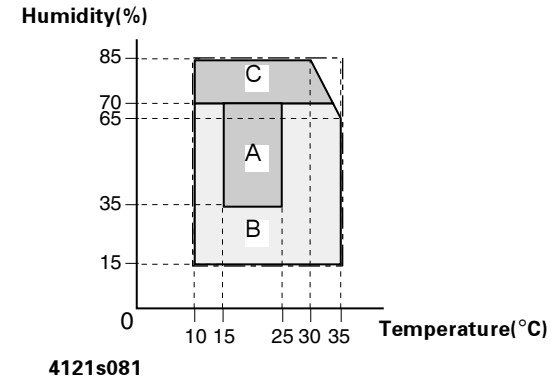

Figure 4-1. Temperature and Humidity Environment

4.1.3 Service Tools

Table 4-2. Tools

+ Driver (No.1)	+ Driver (No. 2)	+ Mini Driver	- Driver

4.1.4 Specification for Screws

Table 4-3. Screws

Figure	D x L	Figure	D x L	Figure	D x L
	3x6 3x8		3x6 3x8		3x8
	3x6		3x8		

Note) D x L = Diameter x Length (mm)

4.2 Disassembly Procedure

The flowchart below is disassembly procedure for EPSON EPL-5800.

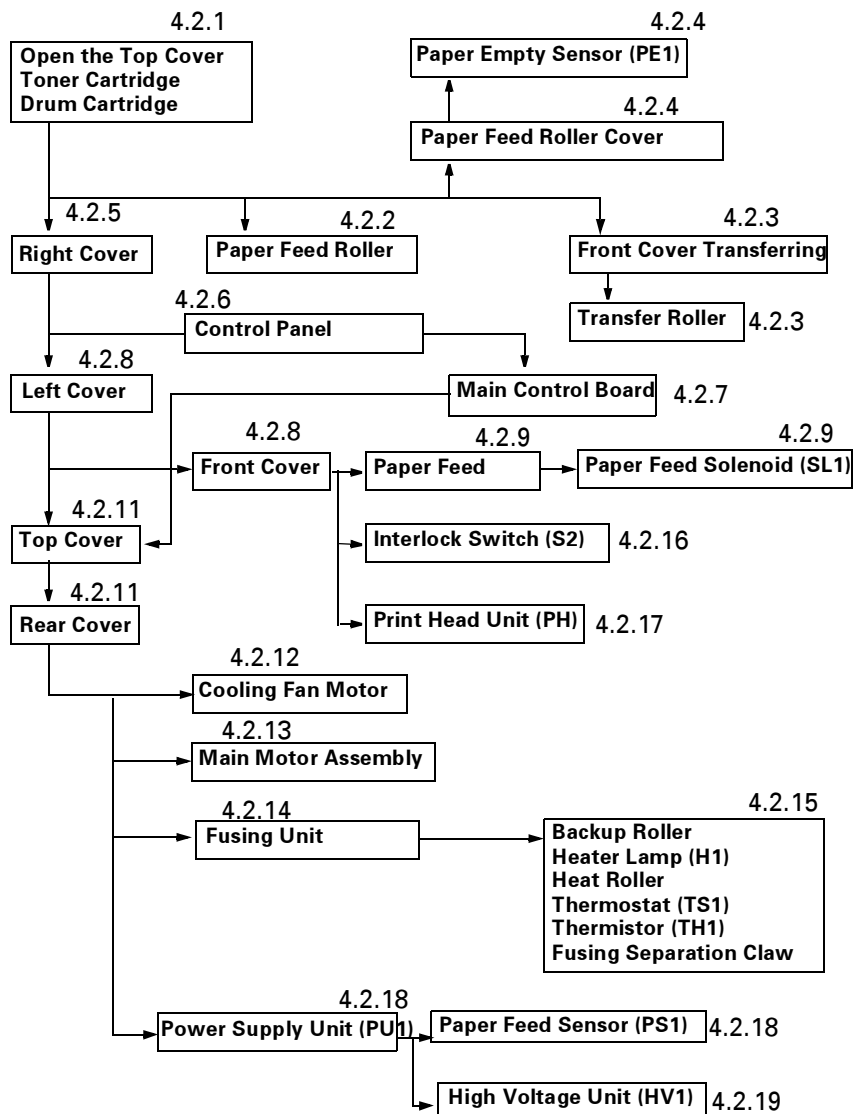

Figure 4-2. Disassembly Flowchart 1

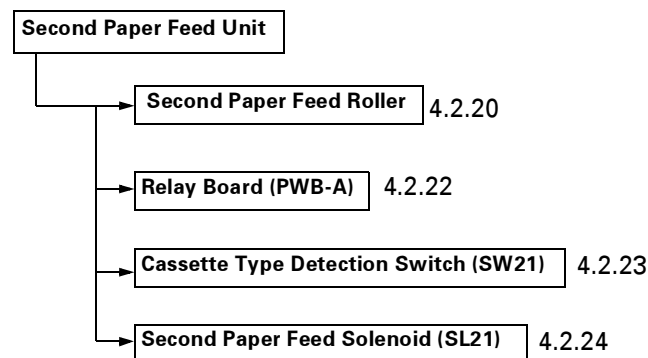

Figure 4-3. Disassembly Flowchart 2

4.2.1 Preparation before disassembling

Before disassembling the printer, removal of the minimum units are necessary.

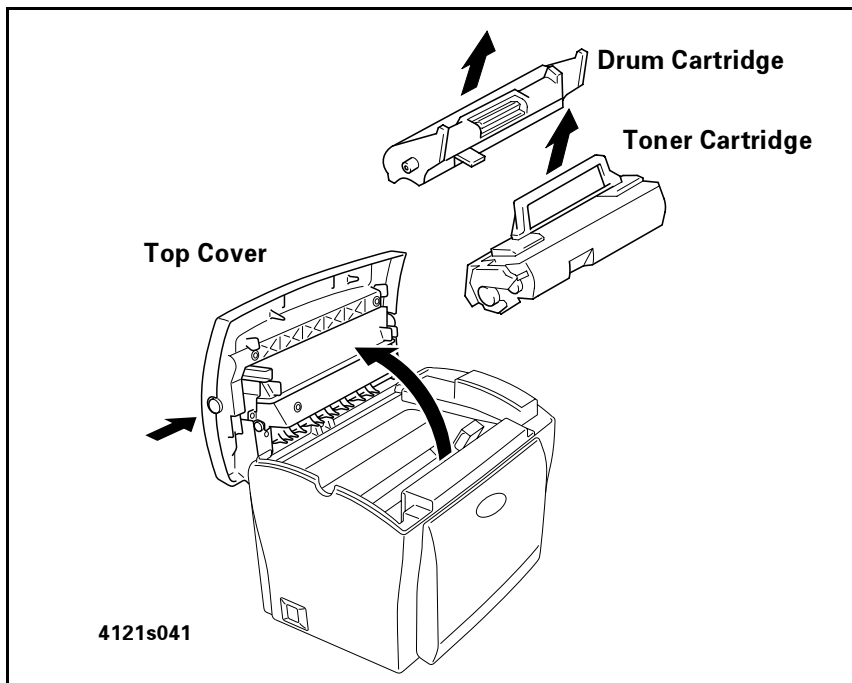

Figure 4-4. Removal of Minimum Units

1. Press the top cover release button, and open the top cover as full open.
2. Take out the toner cartridge.
3. Take out the drum cartridge.

4.2.2 Paper Feed Roller Replacement

1. Open the paper feed roller cover and remove the paper feed roller. (one screw)

NOTE: When installing the paper feed roller, tighten the screw after making sure the pin on the back of the roller goes in the shaft hole.

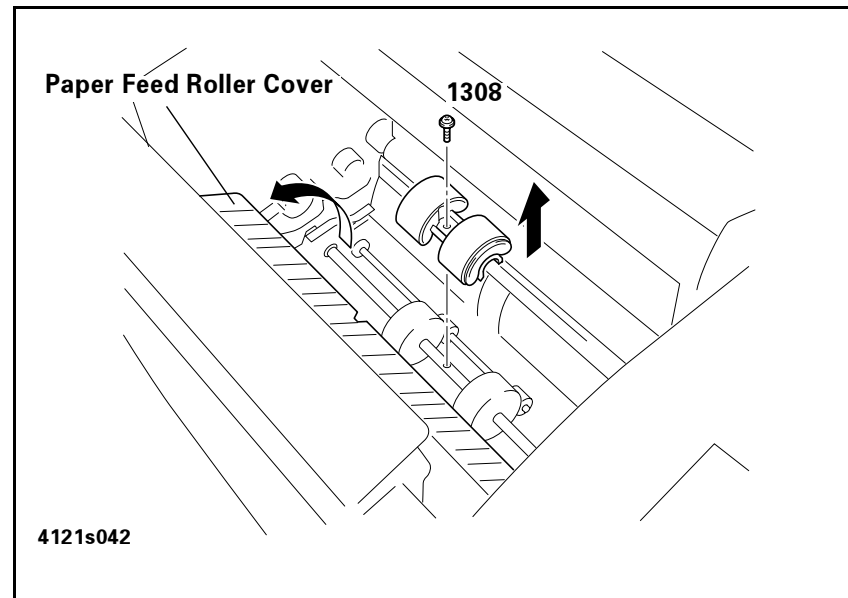

Figure 4-5. Paper Feed Roller Replacement

4.2.3 Transfer Roller Replacement

Replace the transfer roller every about 50,000 sheets.

CAUTION

- Since the life span of the transfer roller and fusing unit are the same, if you need to replace the transfer roller because of worn-out etc., make sure to replace the fusing unit as well.
- Do not touch the surface of the transfer roller nor stain it with chemicals or toner, for the dents or dirt on the surface of the transfer roller badly affects on the printing quality.
- When handling the transfer roller, hold the shaft of the roller or the shaft supports.

1. Use the mini driver and remove the transfer front cover. (two screws)
2. Push down the lever of the shaft supports (white) on the right and left of the transfer roller toward the front, and remove the transfer roller from the transfer roller holder.

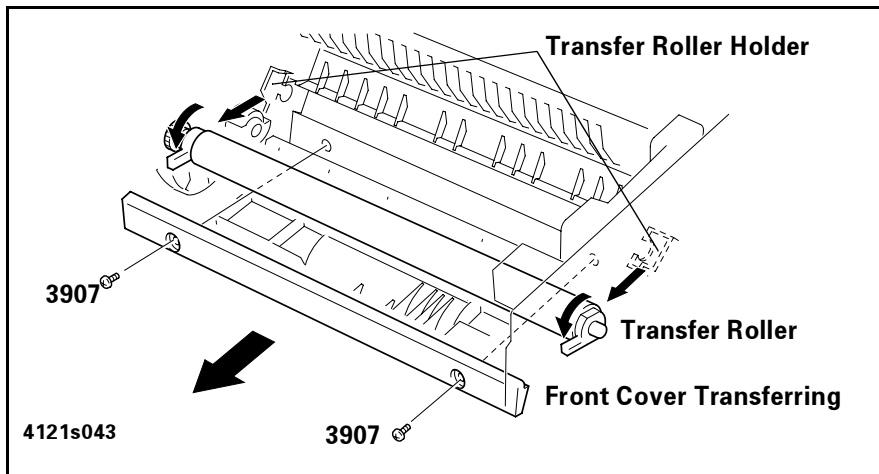

Figure 4-6. Transfer Roller Removal

3. Remove the right and left shaft supports and gear from the removed transfer roller, and install them to the new transfer roller.
4. Insert the transfer roller to the transfer roller holder of the printer, and set the bearing lever to the top.

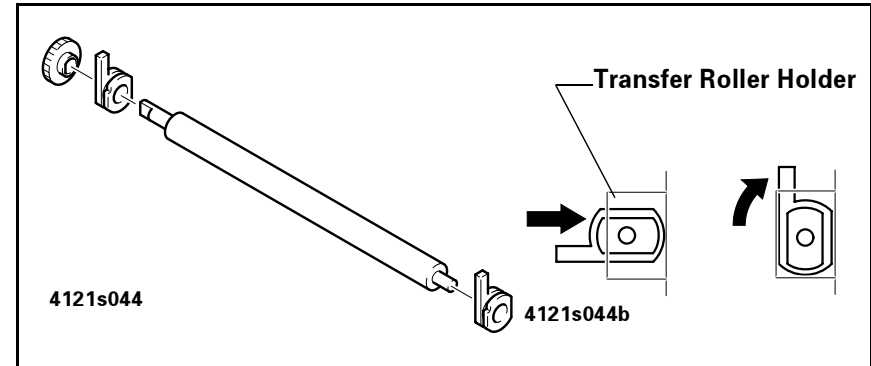

Figure 4-7. Installing the Transfer Roller

5. Install the transfer front cover. (two screws)

4.2.4 Paper Empty Sensor (PE1) Removal

1. Remove paper feed roller cover.
2. Remove the paper empty sensor (PE1) and pull out the connector.

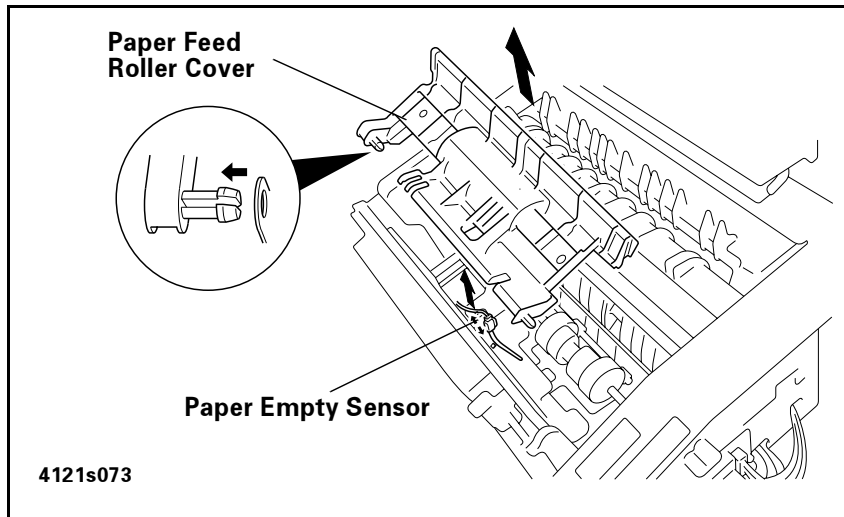

Figure 4-8. Paper Empty Sensor (PE1) Removal

4.2.5 Right Cover Removal

1. Remove the right cover. (two screws, two hooks)

NOTE: When installing the right cover, insert two hooks at the bottom of the right cover to the frame.

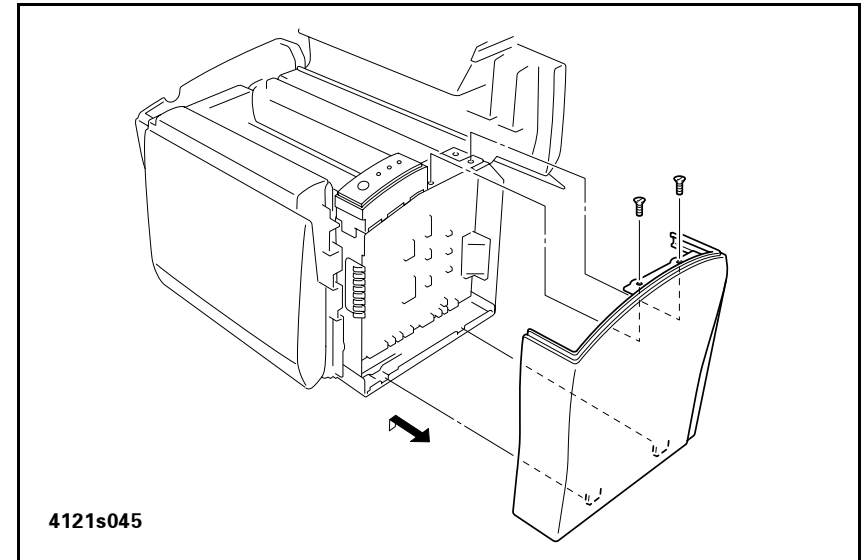

Figure 4-9. Right Cover Removal

4.2.6 Control Panel Removal

1. Remove the control panel. (two screws)

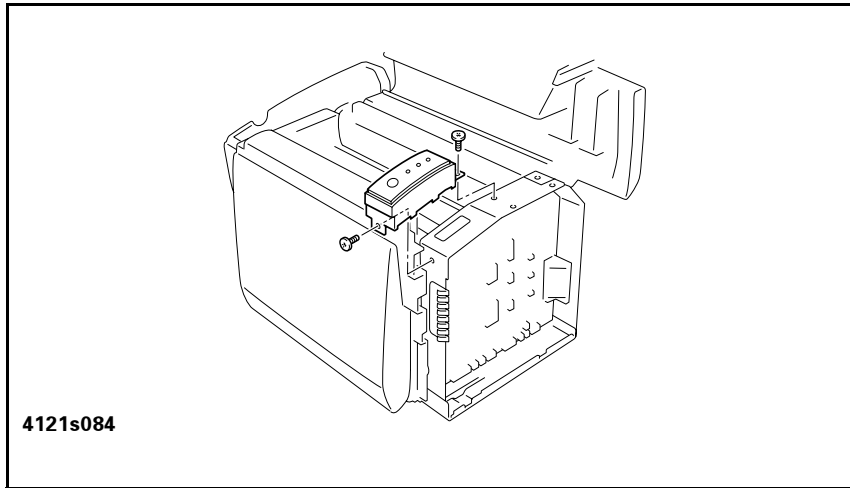

Figure 4-10. Control Panel Removal

4.2.7 Main Control Board (PWB-P) Removal

1. Remove all connectors on the main control board (PWB-P) (twelve connectors) and remove the main control board (PWB-P). (ten screws)

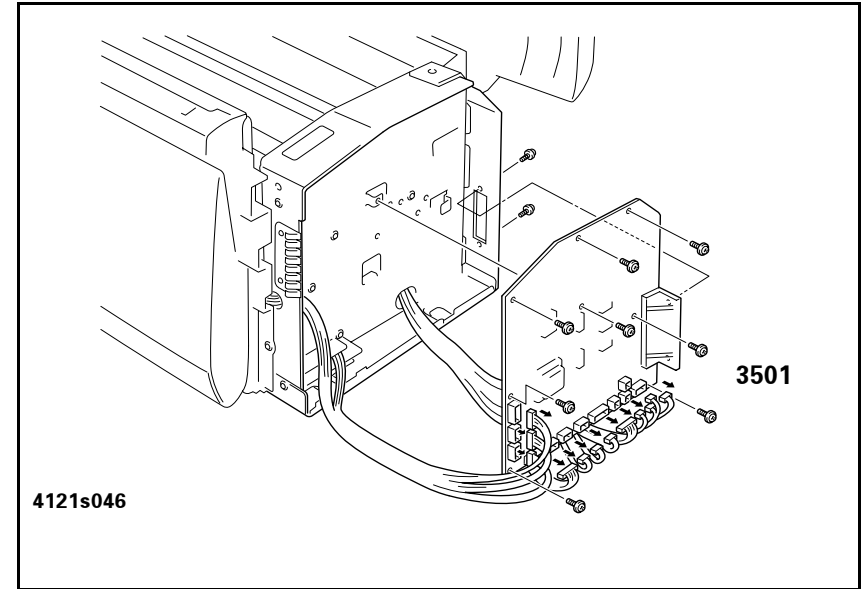

Figure 4-11. Main Control Board (PWB-P) Removal

4.2.8 Left Cover and Front Cover Removal

1. Remove the left cover. (two screws, two hooks)
2. After removing the right cover, remove the front cover. (four screws)

NOTE: Do not catch the paper empty sensor when removing the front cover.
When installing the left cover, insert the hooks at the bottom of the cover to the frame.

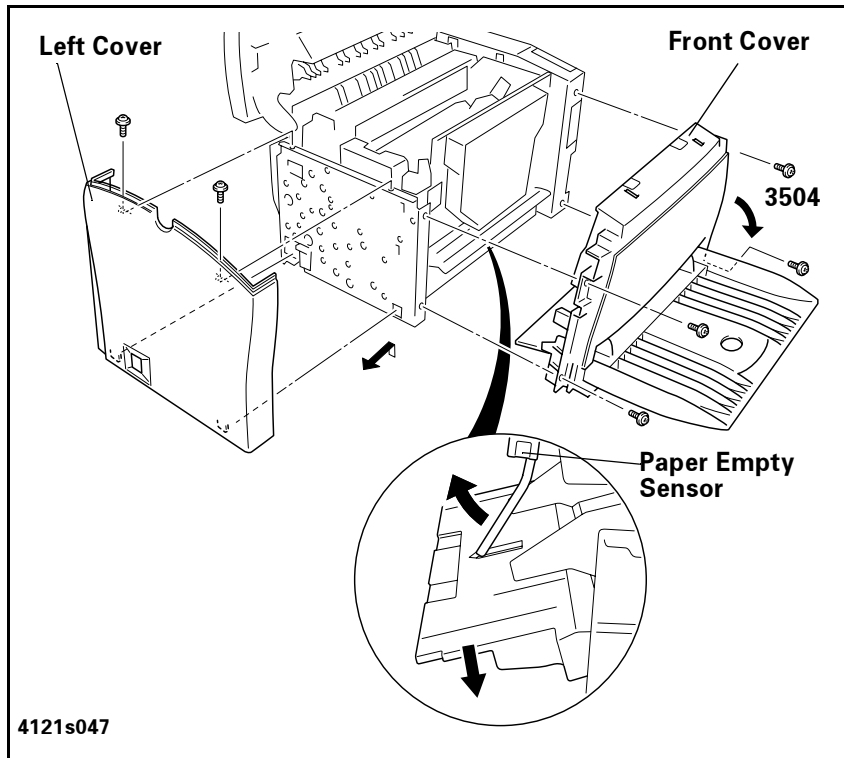

Figure 4-12. Left Cover and Front Cover Removal

4.2.9 Paper Feed Solenoid (SL1) Removal

1. Remove the right cover, the left cover, and the front cover.
2. Close the top cover and turn it down 90° to the back.

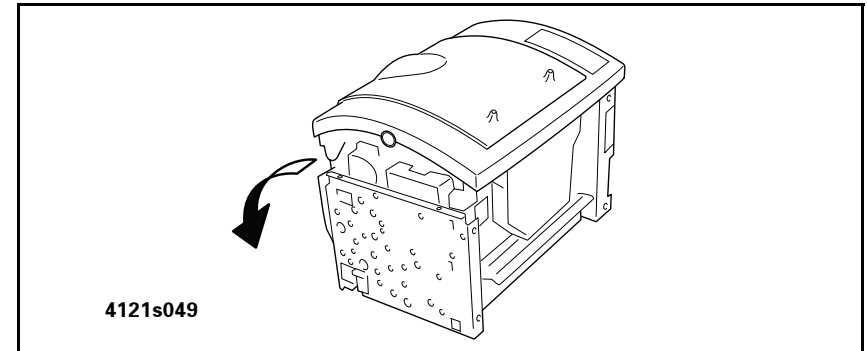

Figure 4-13. Paper Feed Solenoid (SL1) Removal 1

3. Remove the paper feed unit. (five screws, one connector)
4. Remove the paper feed solenoid (SL1). (one screw)

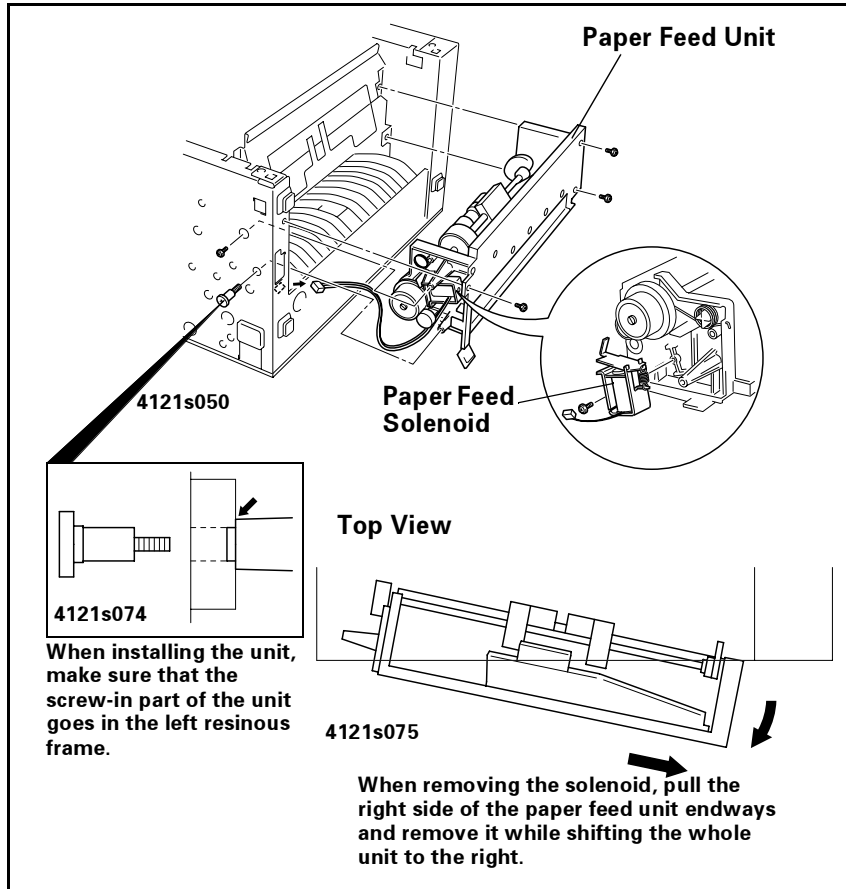

Figure 4-14. Paper Feed Solenoid (SL1) Removal 2

4.2.10 Top Cover Removal

1. Remove the right cover and the left cover.
2. Remove the top cover. (two hooks)

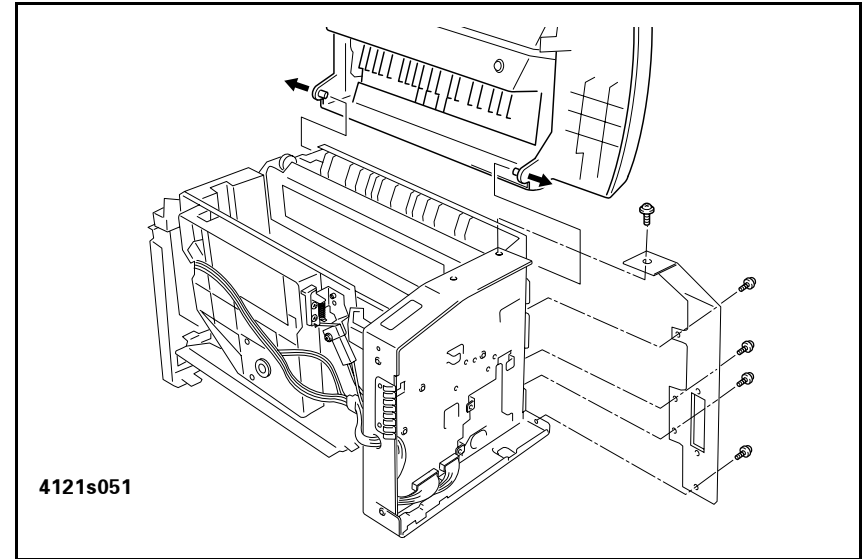

Figure 4-15. Top Cover Removal

4.2.11 Rear Cover Removal

1. Remove the rear cover. (six screws, one connector)
2. Remove the top cover. (two hooks)

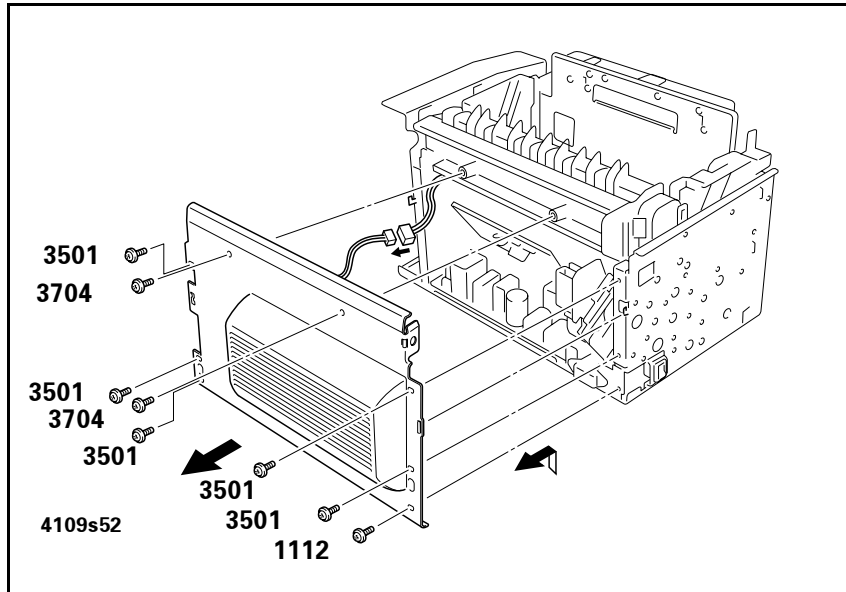

Figure 4-16. Rear Cover Removal

4.2.12 Cooling Fan Removal

1. Remove the rear cover.
2. Remove the cooling fan. (three screws)

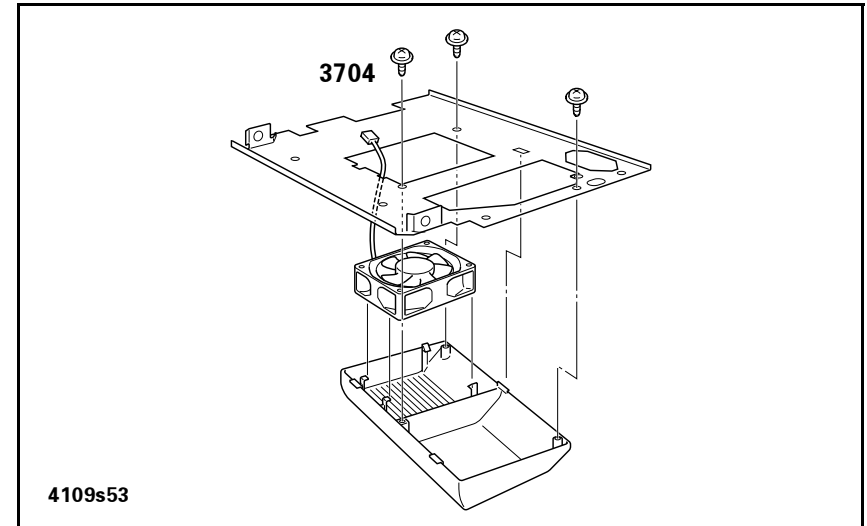

Figure 4-17. Cooling Fan Removal

4.2.13 Main Motor Assembly Removal

1. Remove the rear cover.
2. Remove the main motor assembly. (three screws, one connector)

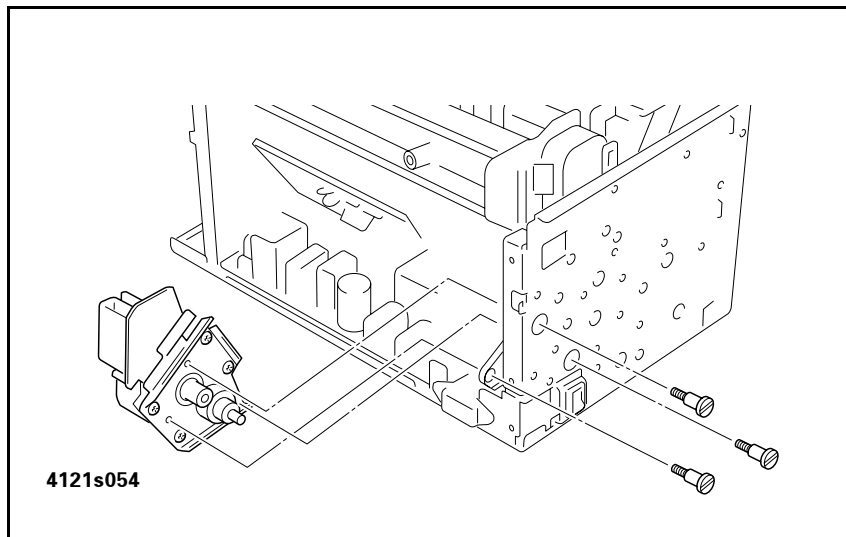

Figure 4-18. Main Motor Assembly Removal

4.2.14 Fusing Unit Removal

Replace the fusing unit by unit basically every about 50,000 sheets.

CAUTION



The life span of the transfer roller and fusing unit are the same. So, if you need to replace the fusing unit because of worn-out etc., make sure to replace the transfer roller as well.

1. Remove the right cover, the left cover, and the rear cover.
2. Remove the fusing unit. (three screws, three connectors)

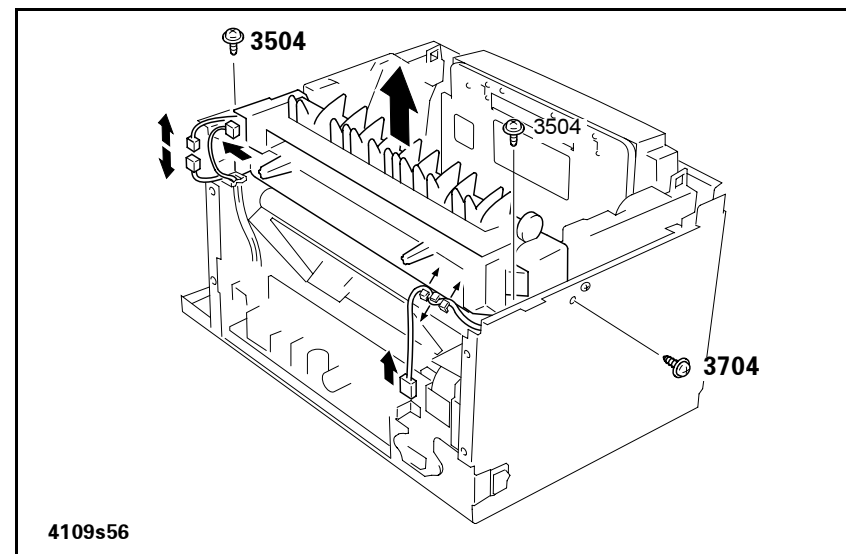

Figure 4-19. Fusing Unit Removal

NOTE: If you need to disassemble the fusing unit because of image quality problems and defective components, follow the instruction in "Fusing Unit Disassembly" on page 78.

4.2.15 Fusing Unit Disassembly

1. Remove two installation screws.
2. Press the left and right hooks (two hooks each) and separate the fixation unit.

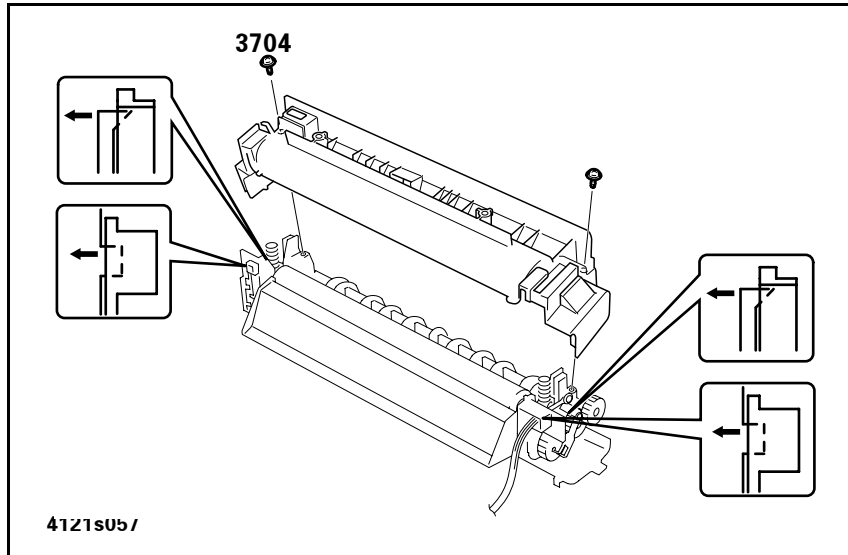

Figure 4-20. Fusing Unit Disassembly

3. Remove the backup roller.
4. Remove the fixation front guide board.
 - (1) Shift the fixation front guide board to the left.
 - (2) Remove the right side of the fixation front guide.
 - (3) Remove the left side of the fixation front guide.

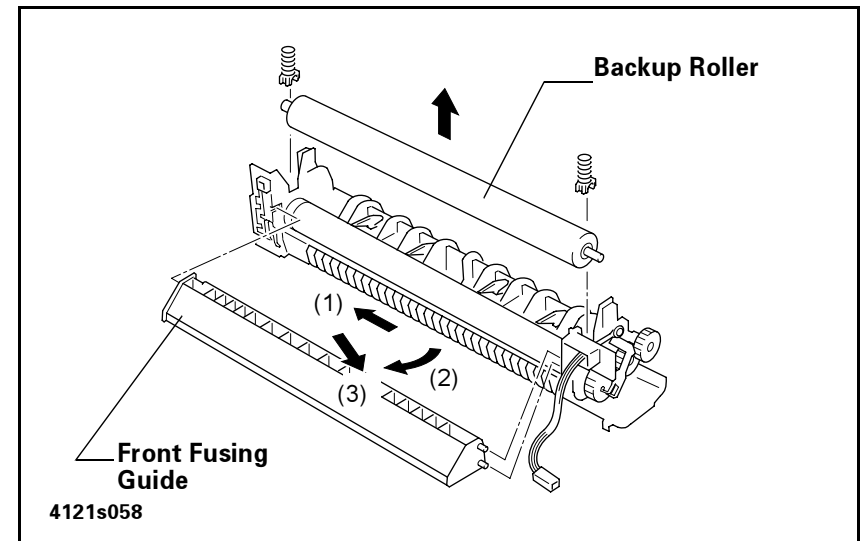

Figure 4-21. Backup Roller and Front Fusing Guide Removal

5. Remove the terminal board. (two screws)
6. Pull out the heater lamp.

CAUTION

- Do not touch the glass of the lamp with bare hands.
- When installing the heater lamp, install it as the voltage indicator faces the gear side.

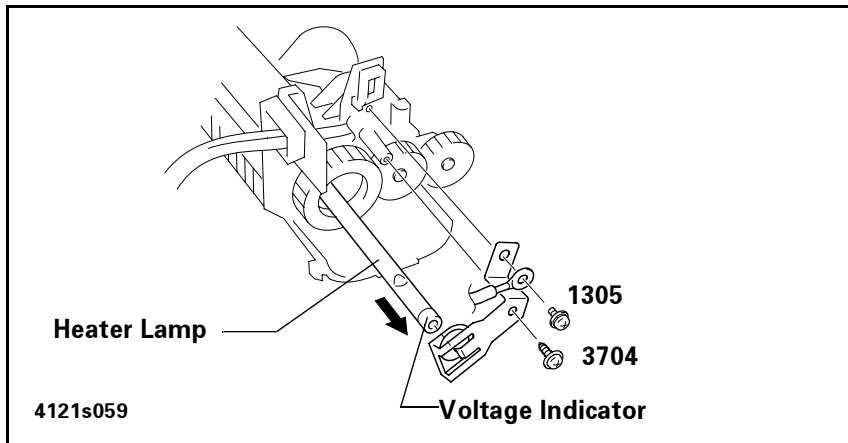

Figure 4-22. Heater Lamp Removal

7. Remove the driven gear from the heat roller.
8. Shift the heat roller to the right side (1) and then shift it to (2) direction, and pull the roller out toward (3) direction.

CAUTION

- To avoid scratching the heat roller surface by the fusing separation claw, when removing or installing the roller, keep the fusing separation claw lifted untouched.

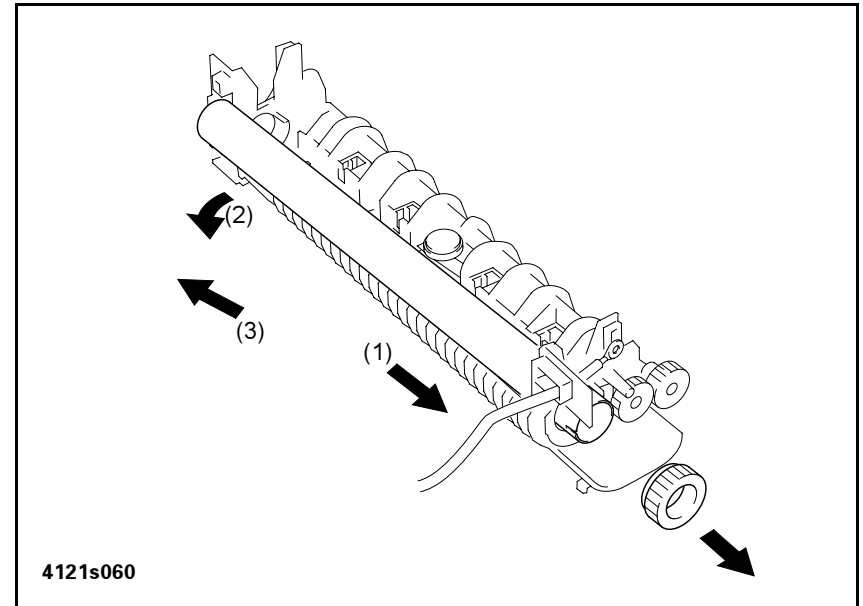

Figure 4-23. Drive Gear Removal

9. Remove the roller assembly. (two screws)
10. Remove the fusing separation claws. (four claws)
11. Remove the thermistor (TH1). (one screw)

NOTE: When installing the thermistor, let the harness through as shown in the figure 1 of the Figure 4-24.

12. Remove the thermostat (TS1). (two screws)

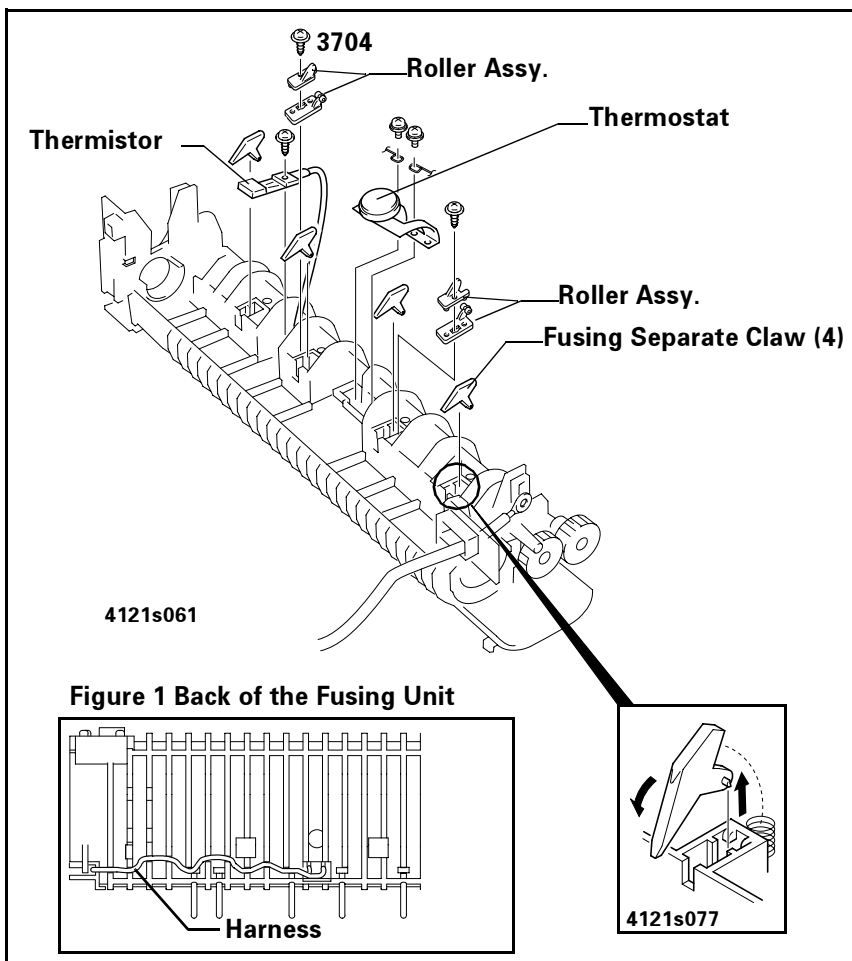

Figure 4-24. Thermistor and Thermostat Removal

4.2.16 Interlock Switch (S2) Removal

1. Remove the right cover, the left cover, and the rear cover.
2. Remove the interlock switch (S2). (one screw, two connectors)

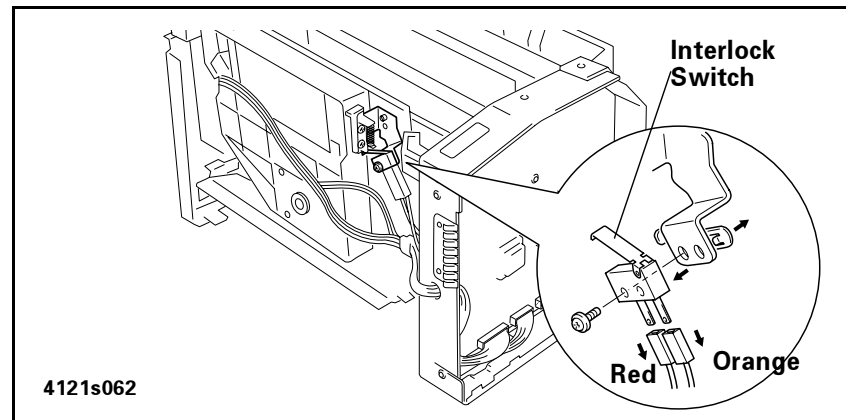

Figure 4-25. Interlock Switch (S2) Removal

4.2.17 Print Head Unit (PH) Removal

1. Remove the right cover, the left cover, and the rear cover.
2. Pull out the connectors (PJ5, PJ9, PJ12) from the main control board and remove the wires from the cold holder.
3. Remove the print head (PH). (seven screws)

NOTE: When installing the print head (PH1), install it with the shutter open.

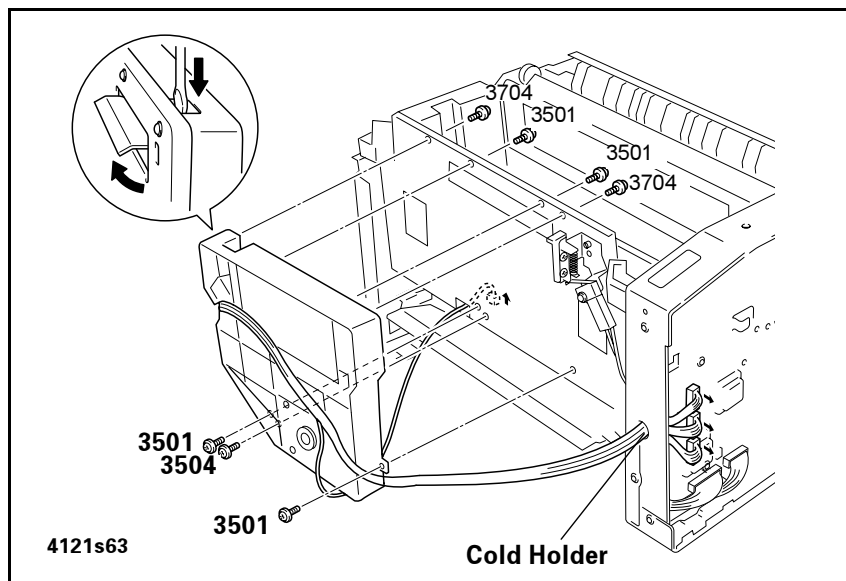

Figure 4-26. Print Head Unit (PH) Removal

4.2.18 Power Unit (PU1), Paper Feed Sensor (PS1) Removal

1. Remove the right cover, the left cover, and the front cover.
2. Pull out PJ7 from the main control board and remove the harness from the cold holder.
3. Remove the power supply unit (PU1). (four screws, two connectors)

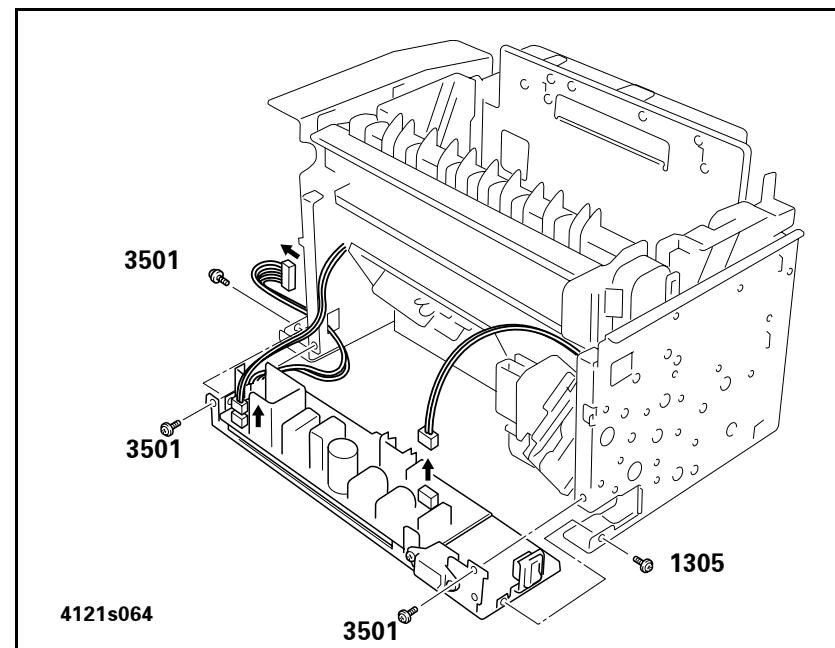

Figure 4-27. Power Unit (PU1) Removal

4. Remove the paper feed sensor (PS1). (one connector)

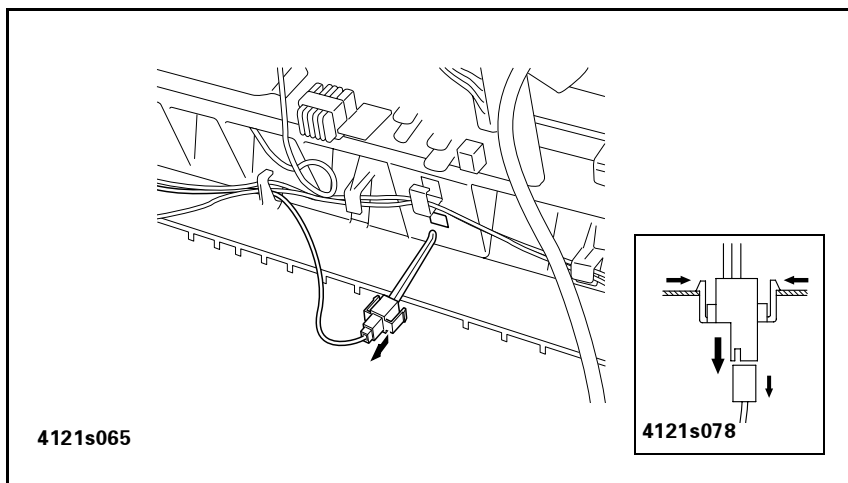

Figure 4-28. Paper Feed Sensor (PS1) Removal

4.2.19 High Voltage Unit (HV1) Removal

1. Remove the right cover, the left cover, and the rear cover.
2. Remove the power supply unit.
3. Remove the high voltage unit (HV1). (three screws, one connector)

NOTE: When installing the high voltage unit (HV1), be careful at the following points.

- Install the earth plate at the rear of the high voltage unit as shown in the Figure 1 in the Figure 4-29.

- Make sure all the contact points (four points) are contacted.

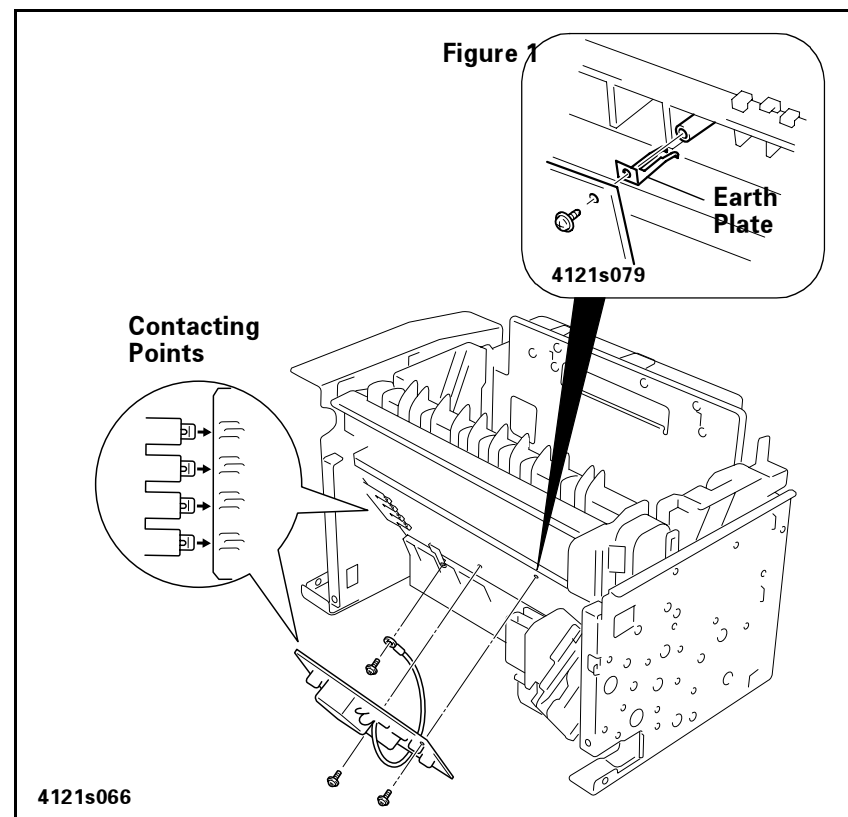

Figure 4-29. High Voltage Unit (HV1) Removal

4.2.20 Second Paper Feed Roller Replacement

1. Separate the second paper feed unit from the printer.
2. Remove the paper feed roller as shown in the figure 1 in the Figure 4-30.
 - 1) Lift the tab of the paper feed roller.
 - 2) Shift the paper feed roller to the right.
 - 3) Remove the paper feed roller.
3. Install a new paper feed roller by reversing the procedure of step 2.

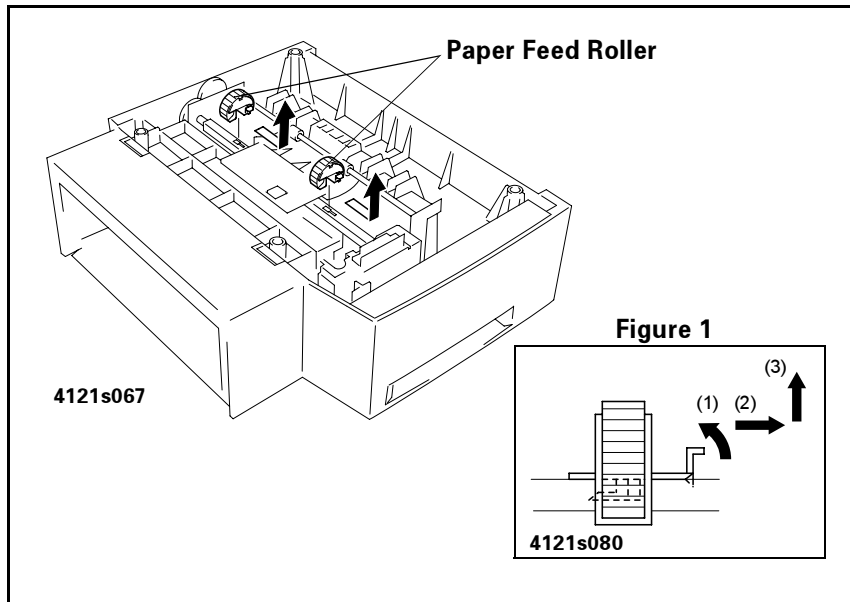

Figure 4-30. Second Paper Feed Roller Replacement

4.2.21 Second Paper Feed Unit Removal

1. Remove the black cover. (one screw, two picks)
2. Remove the actuator.

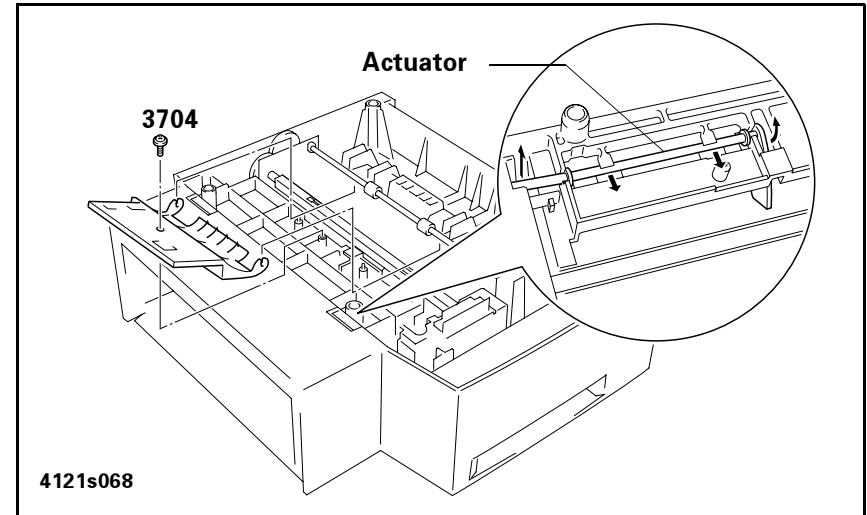

Figure 4-31. Actuator Removal

- Remove the second paper feed unit.

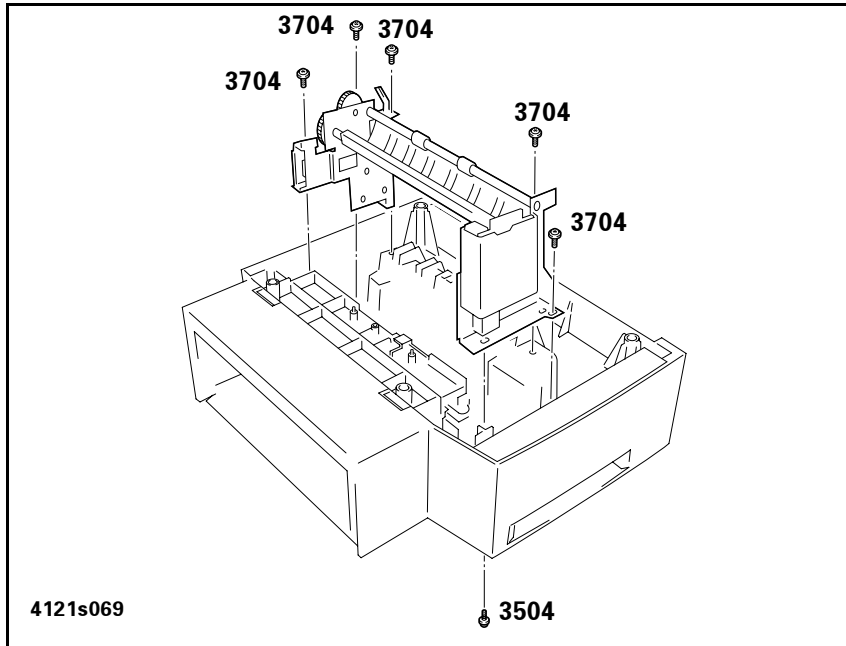

Figure 4-32. Paper Feed Unit Removal

4.2.22 Relay Board (PWB-A) Removal

- Remove the cover. (one screw, two connectors)
- Remove the relay board (PWB-A). (two screws)

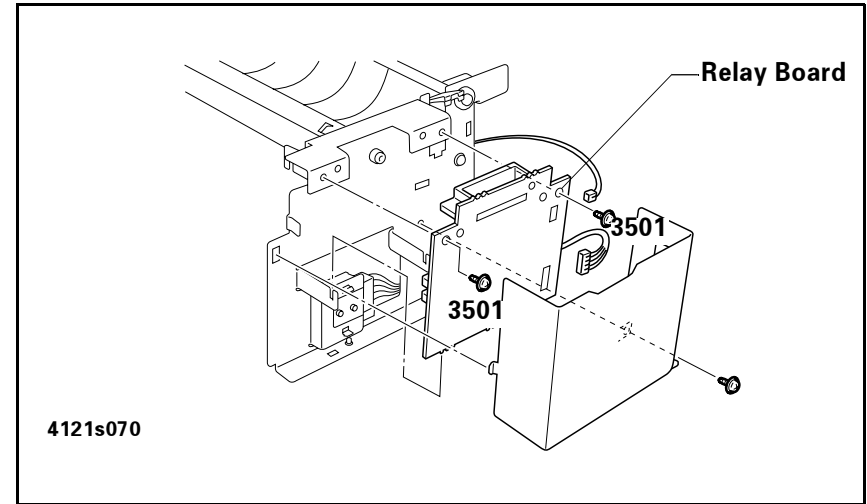

Figure 4-33. Relay Board (PWB-A) Removal

4.2.23 Second Paper Size Detection Switch (SW21) Removal

1. Remove the second paper size detect switch (SW21).

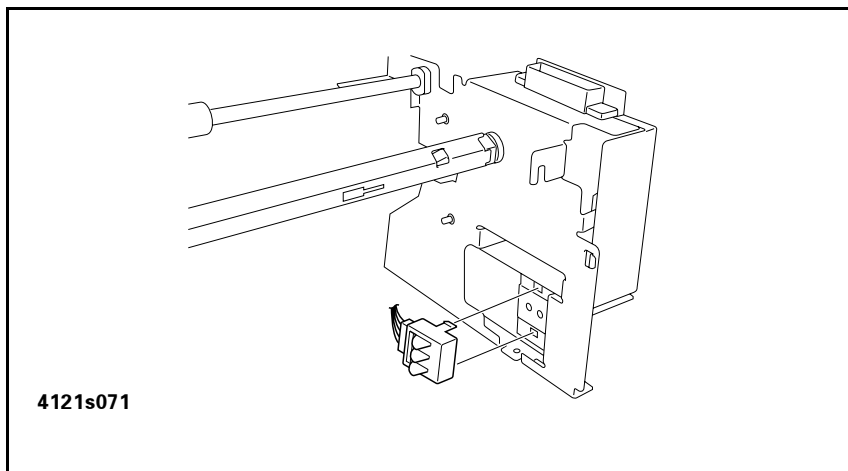

Figure 4-34. Second Paper Size Detection Switch (SW21) Removal

4.2.24 Second Paper Feed Solenoid (SL21) Removal

1. Remove the cover. (one screw)
2. Remove the harness from the wire saddle and remove the second paper feed solenoid (SL21). (one screw, one connector)

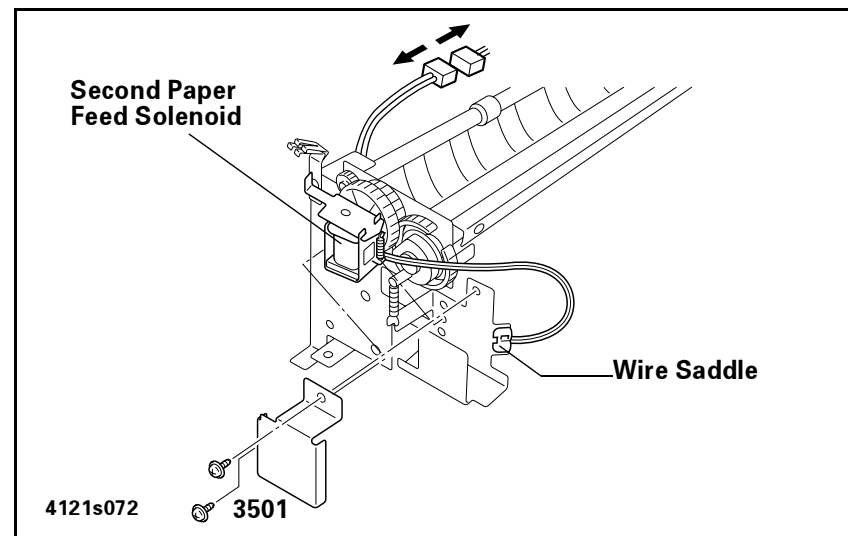

Figure 4-35. Second Paper Feed Solenoid (SL21) Removal

CHAPTER

5

ADJUSTMENT

5.1 Adjustment

This chapter explains adjustment procedure. Adjustment should be done after components and parts are replaced.

5.1.1 Print Start Position Adjustment

After replacing the main control board, make sure the sub scanning start position (d) is 4mm from the top edge of paper. If the sub scanning start position (d) is not 4mm from the top edge of paper, adjust the position by following the instruction below.

ADJUSTMENT BY ACTUAL PRINTING

1. Remove the right cover, and prepare VR1 on the main control board ready for adjustment.
2. If you rotate VR1 on the main control board clockwise, d gets larger. If you rotate VR1 on the main control board counterclockwise, d gets smaller.

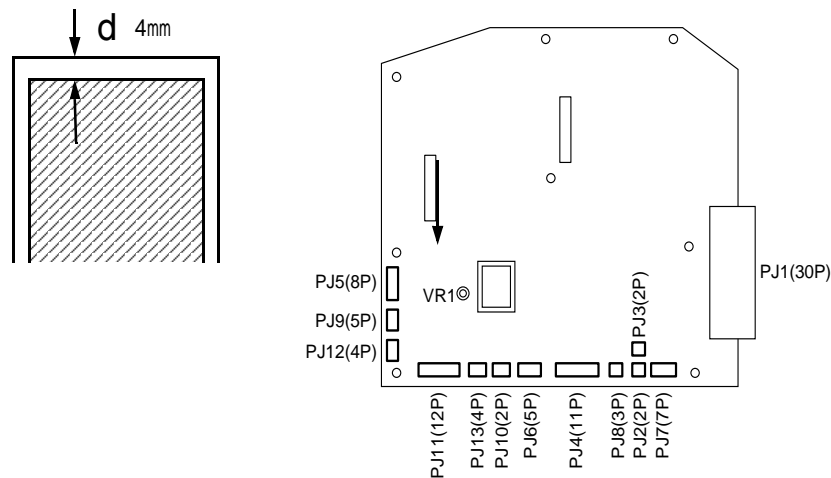

Figure 5-1. Print Start Position Adjustment

ADJUSTMENT BY VOLTAGE CHANGE

1. With the power ON, put + terminal of the tester on VR1 and - terminal on the frame GND.
2. Adjust the position as the tester value becomes $DC2.5 \pm 0.1V$.



Print start position adjustment should basically be performed with the procedure "Adjustment by Actual Printing".

5.1.2 Interlock Switch Position Adjustment

With the power ON, if the printer does not become ON when the top cover is closed, perform the position adjustment of interlock switch (S2) by the following procedure.

1. Open the top cover, and remove the left cover, the right cover and the front cover.
2. Loosen the screw fixing interlock switch (S2), and close the top cover completely.
3. Move the interlock switch (S2) up and down, and tighten the screw where the switch turns ON.

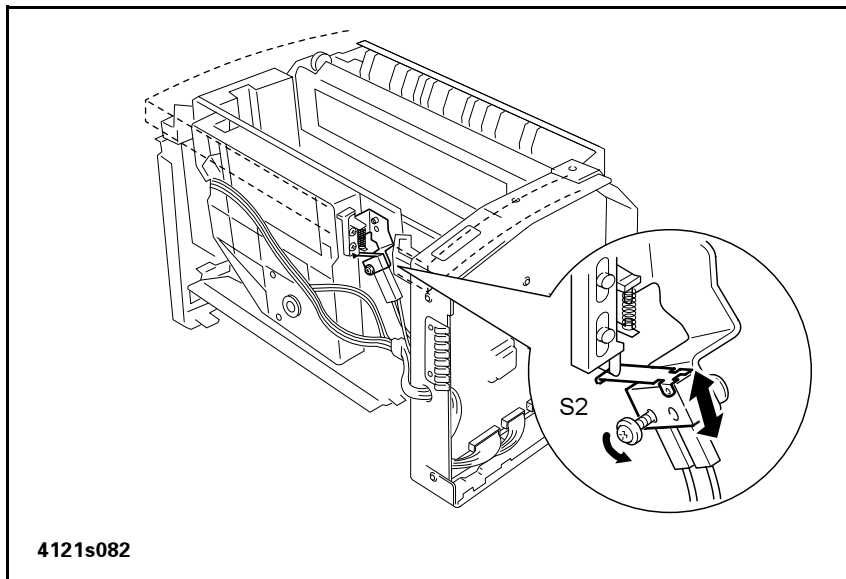

Figure 5-2. Interlock Switch Position Adjustment

5.1.3 USB ID Input

EPL-5800 comes with the USB interface as a standard, and the PC connected to the EPL-5800 via the USB interface identifies the printer by referring to the USB ID information unique to each printer. Since this USB ID information is stored on EEPROM on the main controller board of the printer, you have to re-define the ID information when you need to replace the main board for repair.

CAUTION

When you repair the printer and re-define the USB ID information, you have to notify it to the user to uninstall a previously installed printer driver as it is referring to an old USB ID information.

The program for USB ID input and a supported operating environment is as follows.

- Program
EPL5800.EXE
- Operating environment
 - Supported OS: Windows 95/98
 - Supported I/F: Parallel I/F

PROGRAM SETUP

1. Insert the supplied program diskette labeled as "Disk-1" into a floppy disk drive on the PC, and execute the program "SETUP.EXE".
2. Follow the setup instruction displayed on the PC. (replace the floppy disk to "Disk-2" when you are instructed to do so by the setup program.)
3. When the setup is completed, you can start the program by selecting it from the Program menu.

PROGRAM OPERATION

1. When you execute the program, the following menu window will appear.

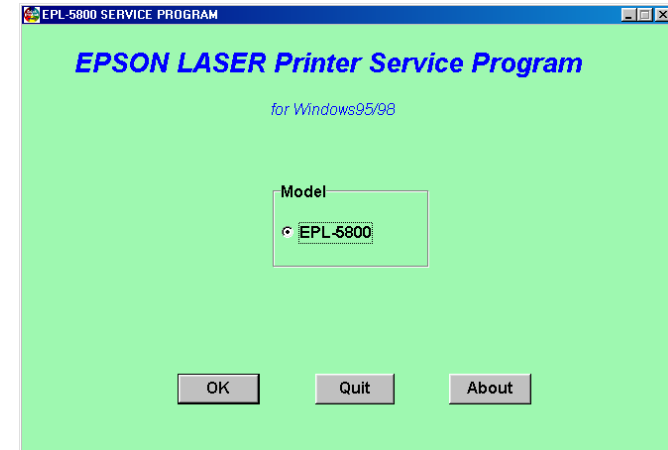

2. Select the printer. (Only one printer: EPL-5800 is listed.)
3. If you need to input new USB ID information to the printer, click "USB ID Input" radio button and click "OK" to proceed.

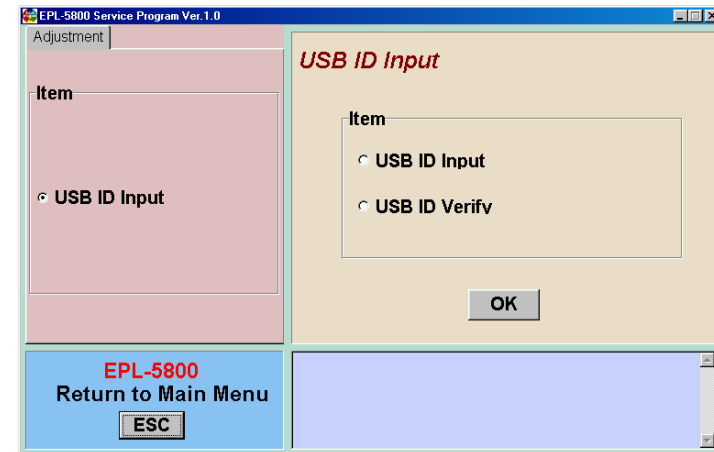

- When the following window appear, input the serial number of the printer and click "Ok" button to store the USB ID information to an EEPROM on the main board of the printer. Take a note of the USB ID value displayed in the status window of the program, and this should be referred to when you check the inputted USB ID later on.

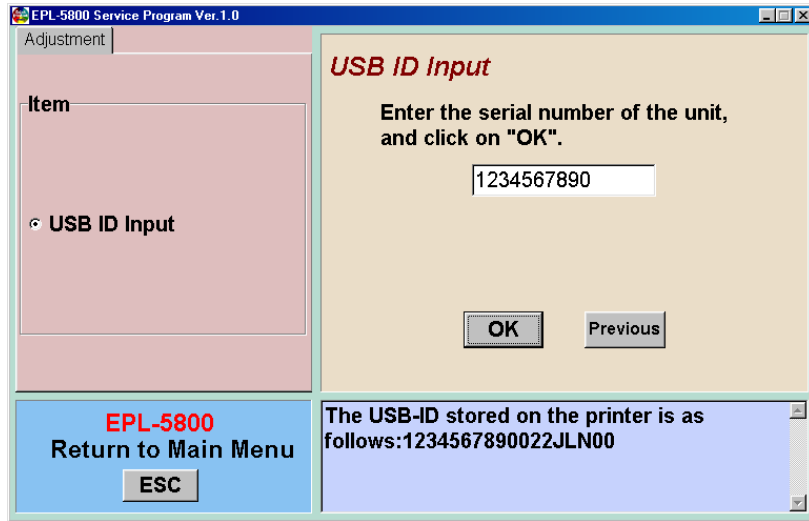

USB ID is 18-digit value and the program automatically generates a rest of ID based on the serial number inputted by the operator.

USB ID CONFIRMATION

When you re-define the USB ID, make sure to verify it with the following procedure.



Make sure to set a paper in the printer before selecting this function, as the program execute the status sheet print operation for checking input USB-ID.

- After executing the program and selecting the printer, click on "Verify USB ID" radio button.

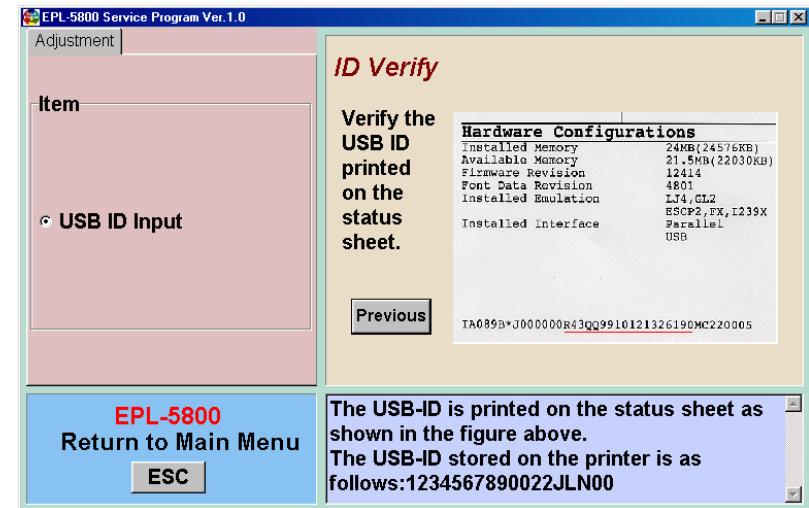

- When you clicking on "OK" button, the program prints the status sheet . Then, confirm that the USB ID value printed on the status sheet is the same as the one you have confirmed when you input it.

CHAPTER

6

MAINTENANCE

6.1 Maintenance

This section gives information necessary for maintaining the printer in its optimum condition. Periodical user maintenance and service maintenance are necessary in order to maintain the high printing quality.

6.1.1 User Maintenance on Main Unit

Table 6-1. User Maintenance on Main Unit

Maintenance Item	Timing	Method
Clean paper-feed roller	When a paper feeding problem occurs.	<ol style="list-style-type: none"> 1. Open the top cover and remove Developer Cartridge and photoconductor unit. 2. Open the paper-feed roller cover and wipe the roller with a damp, soft cloth. Do not use a solvent such as alcohol.

6.1.2 Maintenance of Consumables

A user is responsible for the maintenance of all consumables.

Table 6-2. Maintenance of Consumables

Maintenance Item	Timing	Method
Developer cartridge	Replace after printing approx. 6,000 sheets	<p>Follow the procedure below to replace the Developer cartridge.</p> <ol style="list-style-type: none"> 1. Press the open button and open the top cover. 2. Grasp the handles on the Developer cartridge and pull off the cartridge from the unit. 3. Hold the new Developer cartridge and shake it from side to side. 4. Fully insert the new Developer cartridge into the printer. 5. Close the top cover.
Photoconductor unit	Replace after printing approx. 20,000 sheets	<p>Follow the procedure below to replace the photoconductor unit.</p> <ol style="list-style-type: none"> 1. Press the open button and open the top cover. 2. Grasp the handles on the Developer cartridge and pull off the cartridge from the unit. 3. Pull off the photoconductor unit. 4. Fully insert the new Photoconductor unit into the printer. 5. Insert the Developer Cartridge which removed at (2) above. 6. Close the top cover.

6.1.3 Maintenance by Service Technicians

The following maintenance must be undertaken by a qualified service technician.

Table 6-3. User Maintenance by Service Technicians

Maintenance Item	Timing
Transfer roller.	Clean when a problem occurs. Replace after printing 50,000 sheets.
Fusing unit	Clean when a problem occurs. Replace after printing 50,000 sheets.

CHAPTER

7

APPENDIX

7.1 Overview

This section provides the supplementally informaiton for servicing the EPL-5800.

7.2 Connectors

7.2.1 Connection diagrams

The figure below shows the conneciton between the C361MAIN board and the other electrical circuitries and the printer engine mechanism.

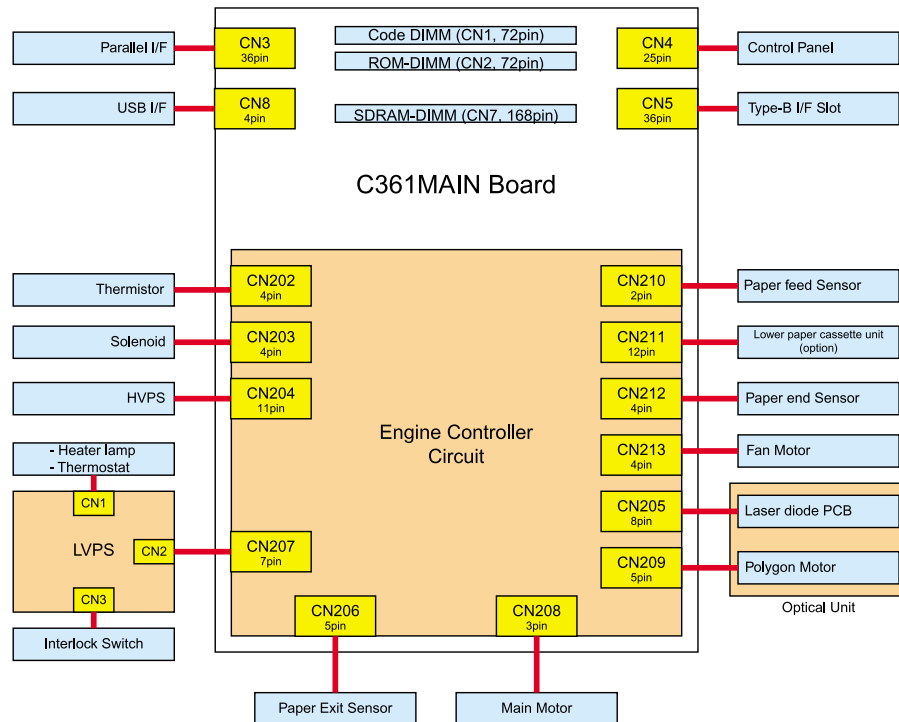

Figure 7-1. Connection diagram - C361MAIN

7.2.2 Connector List

Table 7-1. Connector List

Connector	Description	Pin #	Table
C361MAIN BOARD			
CN1	CODE DIMM	72	Table 7-2
CN2	ROM DIMM	72	Table 7-2
CN3	Parallel I/F	36	Table 7-3
CN4	Control Panel	26	Table 7-4
CN5	Type-B I/F Slot	36	Table 7-5
CN6	(Not used)	---	---
CN7	SDRAM-DIMM	168	Table 7-6
CN8	USB I/F	4	Table 7-7
CN9	(Not used)	---	---
CN10	(Not used)	---	---
CN202	Thermistor	2	---
CN203	Solenoid	4	---
CN204	HVPS	11	---
CN205	Optical unit (Laser diode)	8	---
CN206	Main motor	5	---
CN207	LVPS	7	---
CN208	Paper exit sensor	3	---
CN209	Optical unit (Polygon motor)	5	---
CN210	Paper feed sensor	2	---
CN211	Lower paper cassette unit	12	---
CN212	Paper end sensor	4	---
CN213	Fan motor	4	---

Table 7-1. Connector List

Connector	Description	Pin #	Table
LVPS			
CN1	<ul style="list-style-type: none"> Heater lamp Thermostat 	3	---
CN2	(To C361MAIN board)	7	---
CN3	Interlock Switch	3	---

7.2.3 Connector Pin Assignment

Table 7-2. Connector CN1/2

Pin No.	Signal	I/O	Description
2-9,21-27,35,37,38,49-54,56-60,62-64	D0-D31	I/O	Data bus
11-20,28,29,31-33,36 45,46,55,65-68,71	A0-A23	O	Address bus
44	/CS	O	DIMM Select signal
34	/RD	O	Read signal
47,48	/WR0,/WR1	O	Write signal
40-43	/BE0-/BE3	O	Byte enable signal
69	/ID	I	Detect pin
10,30,61	VCC	---	+5V
1,39,72	GND	---	Ground
70	NC	---	(Not used)

Table 7-3. Connector CN3

Pin No.	Signal	I/O	Description
1	/STB	I	STROBE signal
2 - 9	DATA1-DATA8	I/O	Data signal (Bit 1 to 8)
10	/ACK	O	ACKnowledge signal
11	BUSY	O	BUSY signal
12	PE	O	Paper End signal
13	SELOT	O	(Always HIGH)
14	/AUTO	I	1284 mode request signal
15	NC	---	(Not used)
16	GND	---	Ground
17	CG	---	Chassis ground
18	NC	---	(Not used)
19-30,33	GND	---	Ground
31	/INIT	I	The printer is kept in busy state while this signal is in LOW state.
32	/ERR	O	ERROR signal
34	NC	---	(Not used)
35	+5	---	+5V
36	/SELIN	I	(Always LOW)

Table 7-4. Connector CN4

Pin No.	Signal	I/O	Description
3	/LCD	O	Chip select signal
4	A1	O	Address signal
5	/LCDWR	O	LCD Write signal

Table 7-4. Connector CN4

Pin No.	Signal	I/O	Description
18	/LCDCLK	O	LCD Clock signal
6-9	DB0-DB3	I/O	Data signal
14-16,24-26	LED1-LED6	O	LED output signal
10-13,20-23	/SW1-/SW2	I	Switch input signal
1,2	VCC	---	+5V
17,19	GND	---	Ground

Table 7-5. Connector CN5

Pin No.	Signal	I/O	Description
29-36	D0-D7	I/O	Data signal
25-28	A0-A3	O	Address signal
18	/CS	O	Chip select signal
17	/RD	O	Read signal
16	/WR	O	Write signal
12	INH	O	Disable signal
11	/RESET	O	Reset signal
13	/CMREQ	I	Command-request signal
14	/WRRDY	I	Write-ready signal
15	/RDREQ	I	Read-request signal
7	TXD	---	(Not used)
8	/READY	---	(Not used)
9	RXD	---	(Not used)

Table 7-5. Connector CN5

Pin No.	Signal	I/O	Description
1-6	VCC	---	+5V
19-24	GND	---	Ground
10	NC	---	(Not used)

Table 7-6. Connector CN7

Pin No.	Signal	I/O	Description
33-38,117-121, 123,126	A0-A12	O	Address signal
132	A13	---	(Not used)
39,122	BA0,BA1	O	Bank-select address signal
2-5,7-11,13-17,19, 20,55-58,60,65-67, 69-72,74-77,86-89, 91-95,97-101,103, 104,139-142,144, 149-151, 153-156,158-161	DQ0-DQ63	I/O	Data bus
30,45,114,129	/CS0-/CS3	O	Chip-select signal
115	/RAS	O	Row-Address Strobe signal
111	/CAS	O	Column-Address Strobe signal
27	/WE	O	Write-enable signal
28,29,46,47,112,113, 130,131	DQMB0-DQMB7	O	Byte-data mask signal
42,79,125,163	CK0-CK3	O	Clock input
63,128	CKE0,CKE1	O	Clock-enable signal
82	SDA	I/O	SPD data
83	SCL	O	SPD clock signal

Table 7-6. Connector CN7

Pin No.	Signal	I/O	Description
165-167	SA0-SA2	O	SPD address signal
21,22,24,25,31,44, 48,50- 53,61,62,80,81, 105,106,108,109, 134-137,145-147, 164	NC	---	(Not used)
6,18,26,40,41,49,5 9, 73,84,90,102,110,1 24, 133,143,157,168	VCC	---	+3.3V
1,12,23,32,43,54,6 4, 68,78,85,96,107,11 6, 127,138,148,152,1 62	VSS	---	Ground

Table 7-7. Connector CN8

Pin No.	Signal	I/O	Description
1	POWER	---	+5V
2	D-	I/O	Data-
3	D+	I/O	Data+
4	GND	---	Ground

7.3 Component Layout

The figure below shows the component layout of the C361MAIN Board.

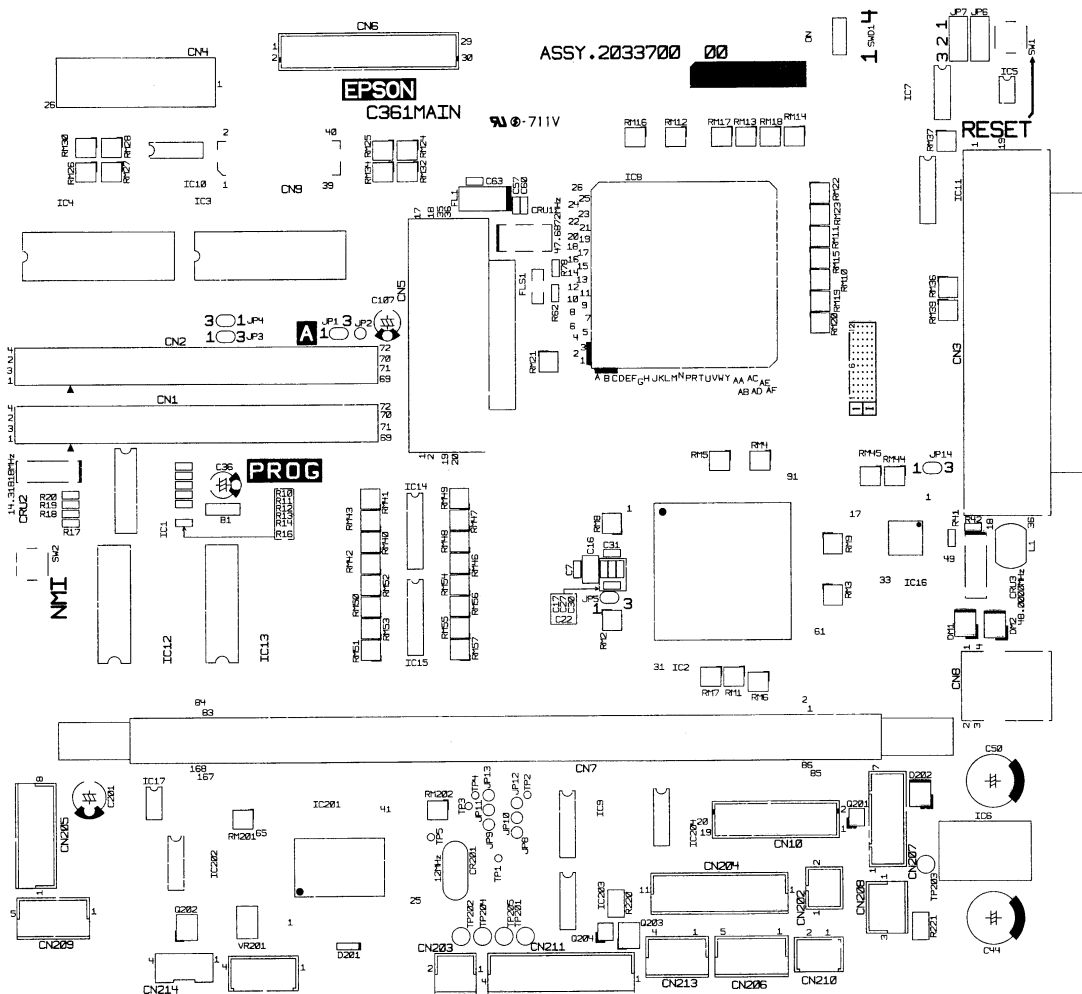
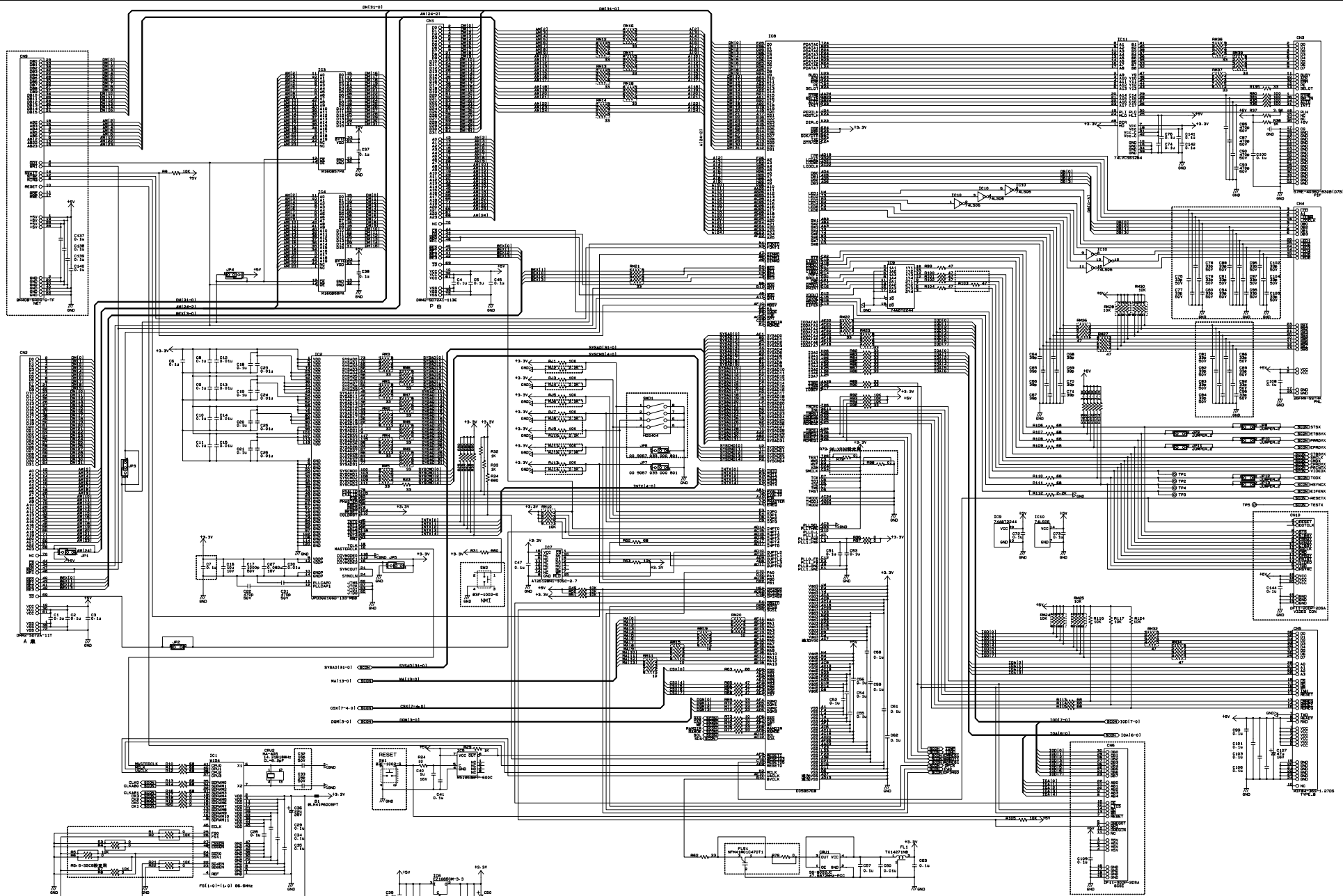

Figure 7-2. Component Layout - C361MAIN BOARD

7.4 Circuit Schematics

The circuit schematics of C361MAIN board is provided on the following pages.

- C361MAIN BOARD (No.1)
- C361MAIN BOARD (No.2)
- C361MAIN BOARD (No.3)



1

2

3

4

5

6

7

8

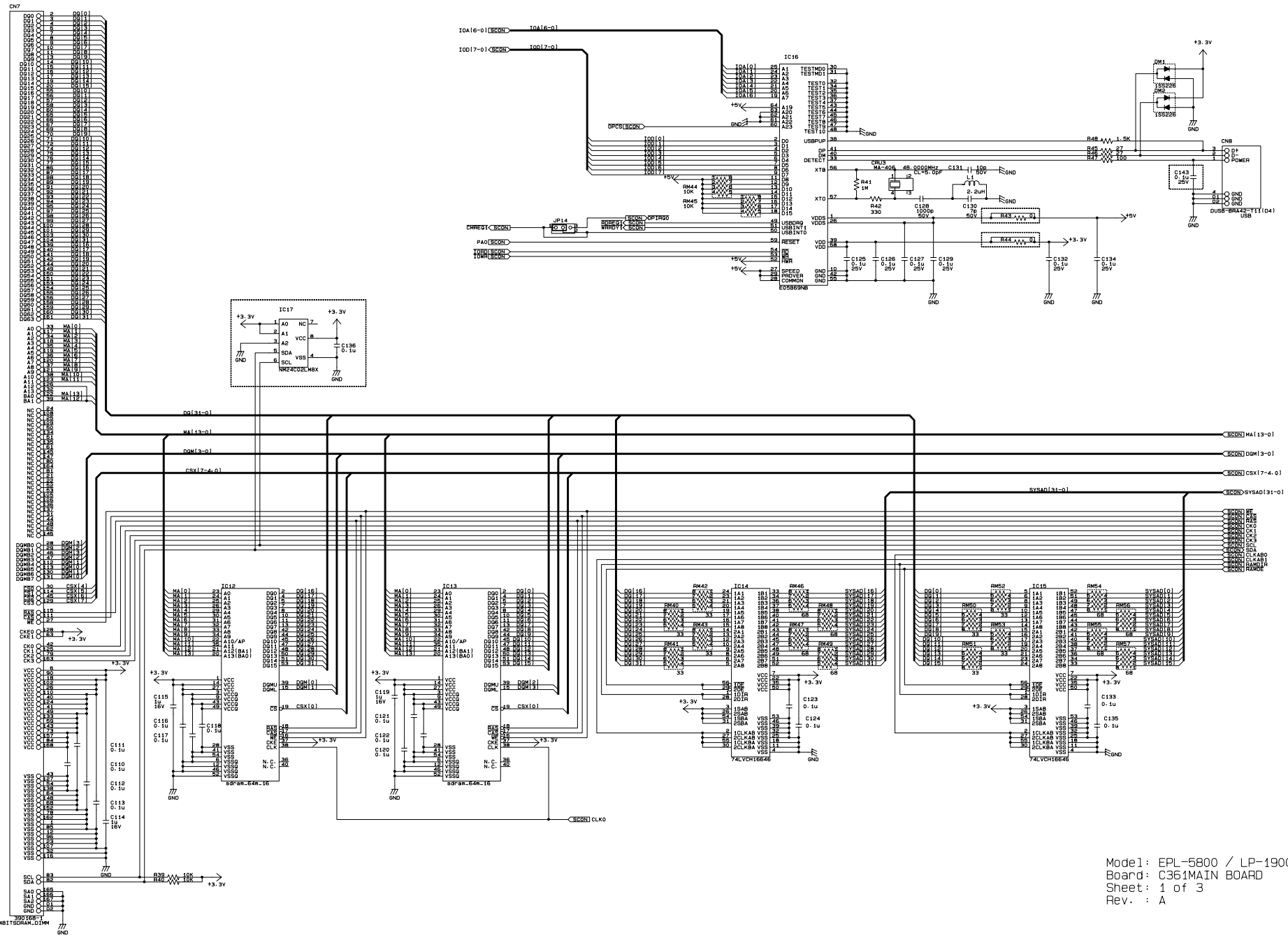

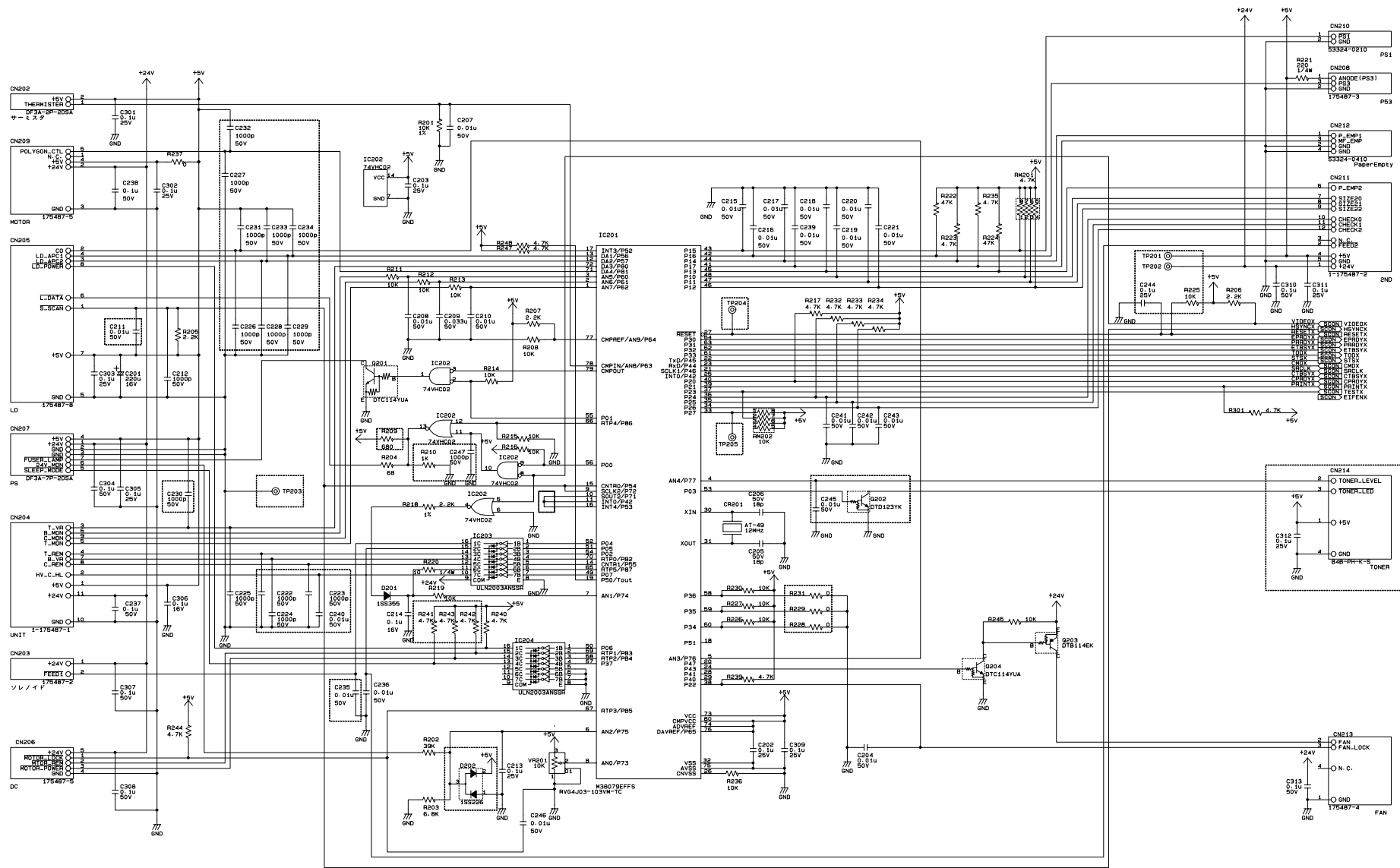

注1) □ 内はIC201の下にPatternをひかない事。
 注2) □ 内は未実装

Model: EPL-5800 / LP-1900
 Board: C361MAIN BOARD
 Sheet: 1 of 3
 Rev.: A

7.5 Parts List

The table below lists the available service parts of the EPL-5800.

Main Unit

Table 7-8. Service Parts List - Main Unit

Ref. No.	Parts Name
1-01	COVER
1-02	EARTH GROUND
1-03	TRAY
1-04	TRAY
1-05	TOP COVER
1-06	COVER
1-08	FRONT COVER
1-10	COVER
1-11	TRAY
1-12	COVER
1-13	REGULATING PLATE
1-15	REGULATING PLATE
1-16	GEAR
200	"BOARD ASSY.,MAIN"
2-01	EARTH GROUND
2-02	TORSION SPRING
2-03	MEMBER
2-04	HOLDER
2-05	LEVER
2-06	SHOULDER SCREW
2-07	TORSION SPRING

Table 7-8. Service Parts List - Main Unit

Ref. No.	Parts Name
2-08	COVER
2-09	ROLLER
2-10	GEAR ASSY
2-11	GUIDE
2-12	GUIDE
3-01	PAPER PICK UNIT
3-02	ROLLER
3-03	SEPARATOR PAD
3-04	SOLENOID
4-01	ACTUATOR
4-02	PHOTO INTERRUPTER(PS3)
4-03	BUSHING
4-04	FUSING ROLLER-RR
4-05	BUSHING
4-06	TUBE LAMP(H1 230V)
4-07	FUSING ROLLER
4-08	PRESSURE SPRING
4-09	SAPARATOR
4-10	BUSHING
4-11	THERMAL SWITCH
4-12	THERMISTOR
4-13	FUSING UNIT 230V
450	PANEL
5-01	TORSION SPRING
5-02	FRAME

Table 7-8. Service Parts List - Main Unit

Ref. No.	Parts Name
5-03	MOTOR
5-04	DRIVE UNIT
5-05	WIRE HARNESS ASSY
5-06	RUBBER FOOT
5-07	HV TRANSFORMER
5-08	SWITCH(PS2)
5-09	TRANSFER UNIT
5-10	GUIDE PLATE
5-11	ROLLER
6-01	BRACKET ASSY
6-02	FAN MOTOR
6-03	DUCT
6-04	SWITCH(PE1)
6-05	SWITCH
6-06	RUBBER FOOT
6-07	LEVER
6-08	EARTH GROUND
6-10	EARTH GROUND
7-01	POWER SUPPLY
7-02	FERRITE CORE
7-03	GUIDE
7-04	PRINT HEAD UNIT
7-05	GUIDE ASSY
7-06	POWER CABLE
0601	PIN

Table 7-8. Service Parts List - Main Unit

Ref. No.	Parts Name
1305	SCREW
1308	SCREW
2514	SCREW
2903	SCREW
3501	TAPPING SCREW
3541	TAPPING SCREW
3544	TAPPING SCREW
3704	TAPPING SCREW
3727	TAPPING SCREW
3730	TAPPING SCREW
3907	TAPPING SCREW
3923	TAPPING SCREW
4012	TAPPING SCREW
8302	WASHER
9105	RETAINING RING
9109	RETAINING RING

Lower Paper Cassette Unit

Table 7-9. Service Parts List - Lower Paper Cassette Unit

Ref. No.	Parts Name
8-01	PW BOARD-A(PWB-1)
8-02	PLATE
8-03	BUSHING
8-04	BRACKET
8-05	SHAFT
8-06	ROLLER
8-07	ROLLER
8-08	GUIDE
8-09	BUSHING
8-10	GEAR 15T
8-11	GEAR 26/32T
8-12	TENSION SPRING
8-13	GEAR 34T
8-14	SOLENOID
8-15	GUIDE
8-16	SWITCH(SW21)
8-17	COVER
9-01	CASSETTE ASSY A4
9-02	WIRING SADDLE 5.2H
9-03	WIRING SADDLE 5.2H
9-04	EDGE COVER 8.5H
9-05	CABLE TIE
0509	PIN
3501	TAPPING SCREW

Table 7-9. Service Parts List - Lower Paper Cassette Unit

Ref. No.	Parts Name
3504	TAPPING SCREW
3704	TAPPING SCREW
3709	TAPPING SCREW
3906	TAPPING SCREW
9107	RETAINING RING
9112	RETAINING RING

7.6 Exploded View Diagrams

The exploded view diagrams are provided on the following pages.

- Housing components
- Paper Eject mechanism
- Paper supply mechanism
- Fusing unit
- Main drive / Transfer unit
- Frame
- Electrical components
- Option: Lower Paper Cassette Unit (1)
- Option: Lower Paper Cassette Unit (2)

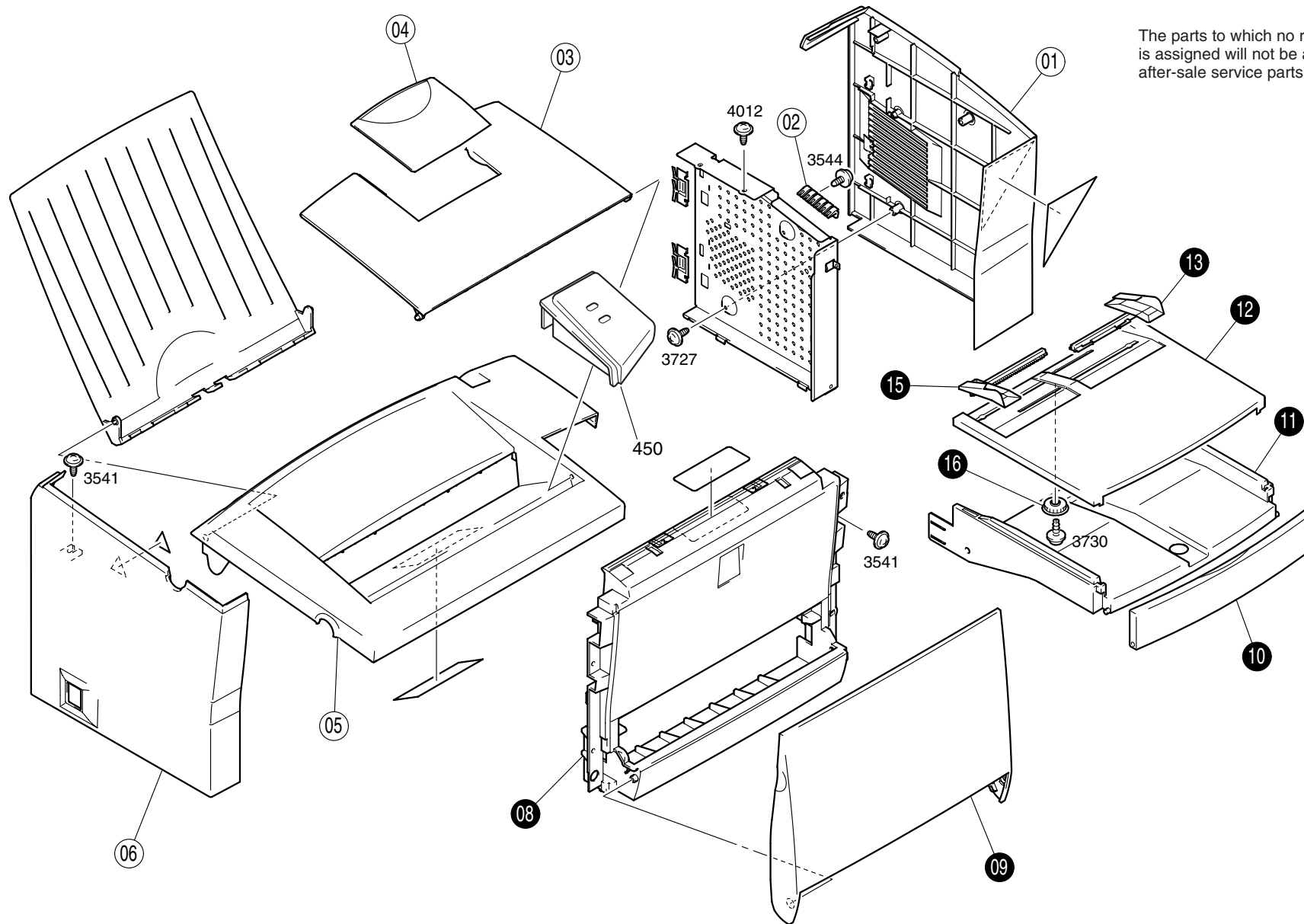

The parts to which no reference number is assigned will not be available as after-sale service parts.

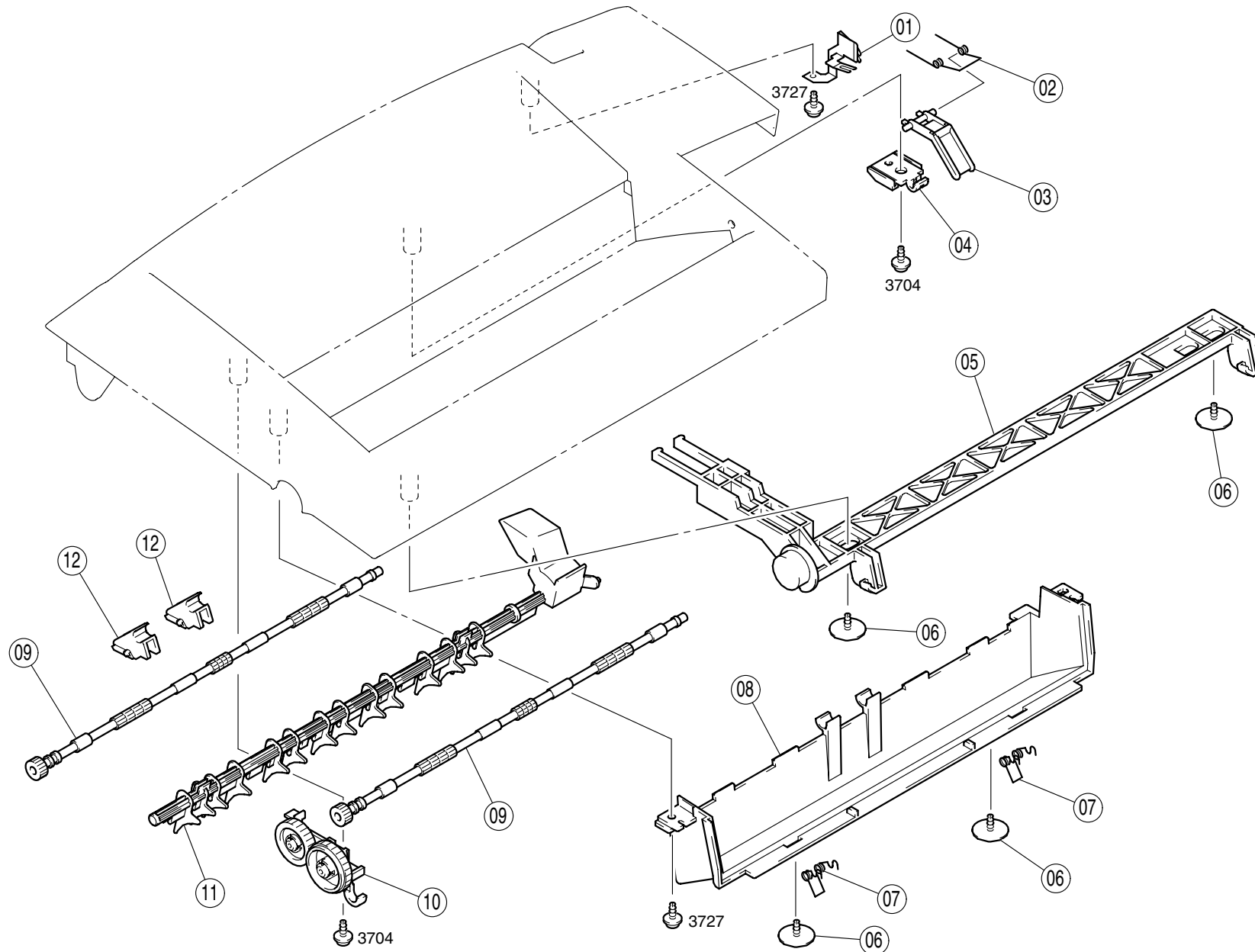

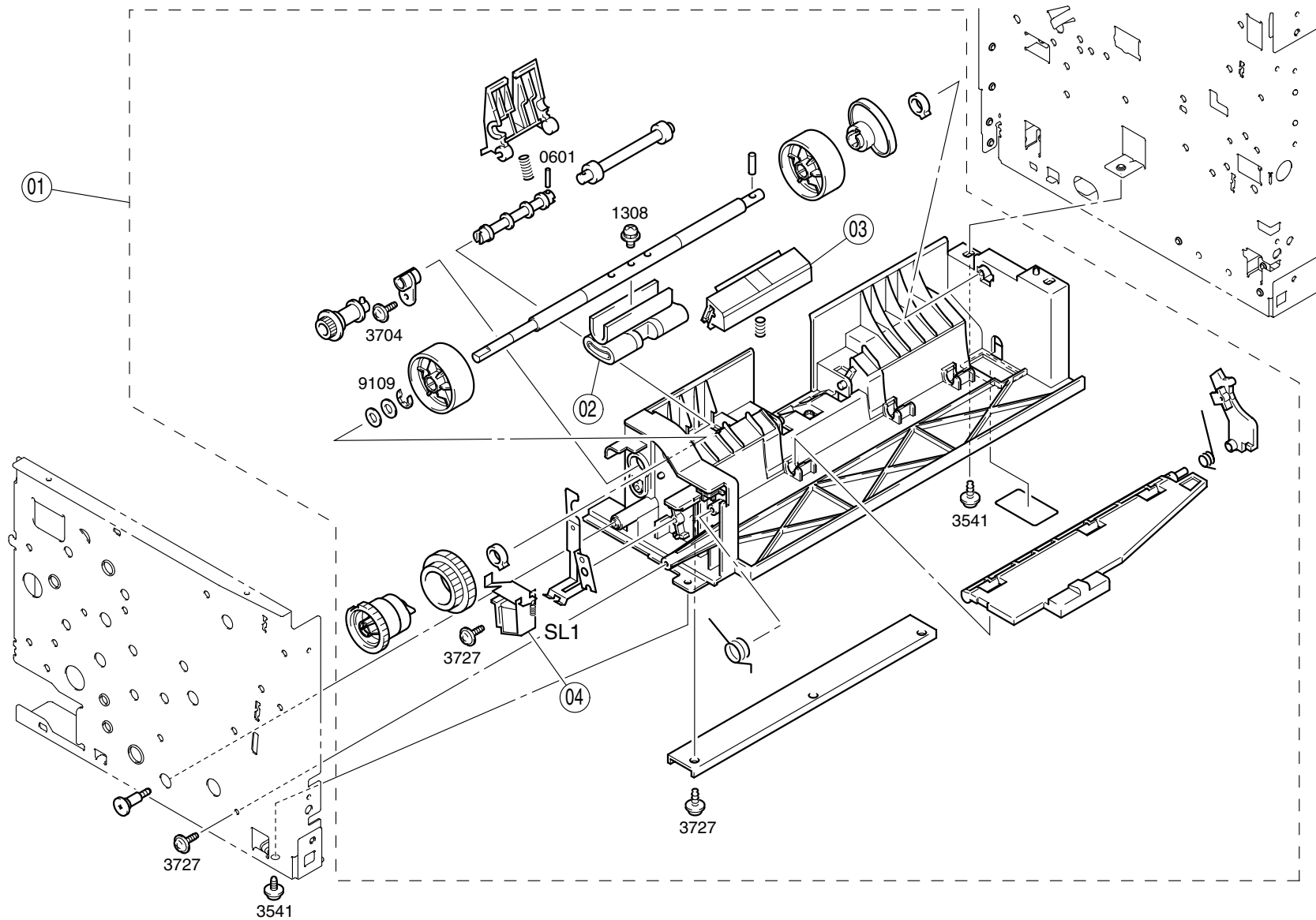

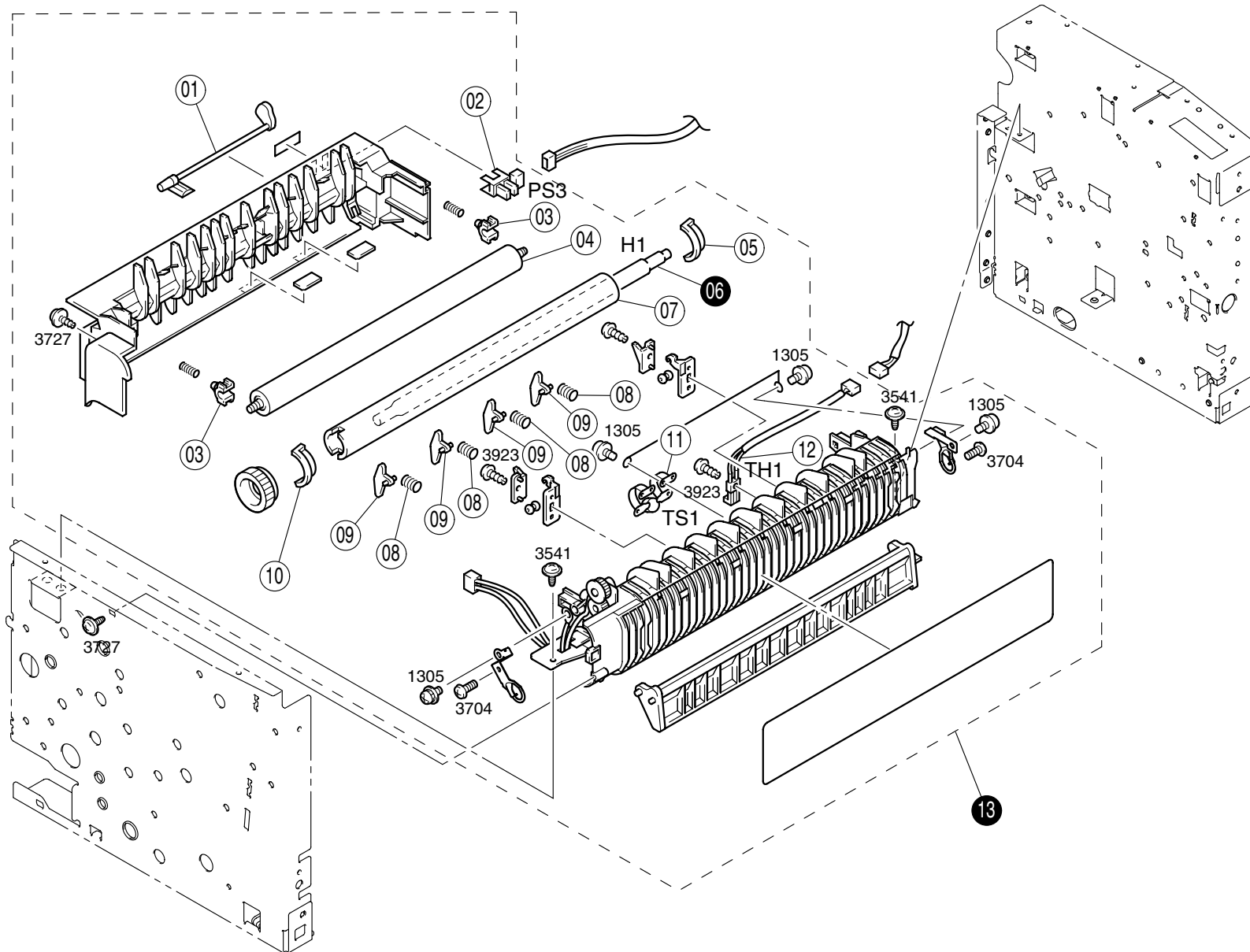

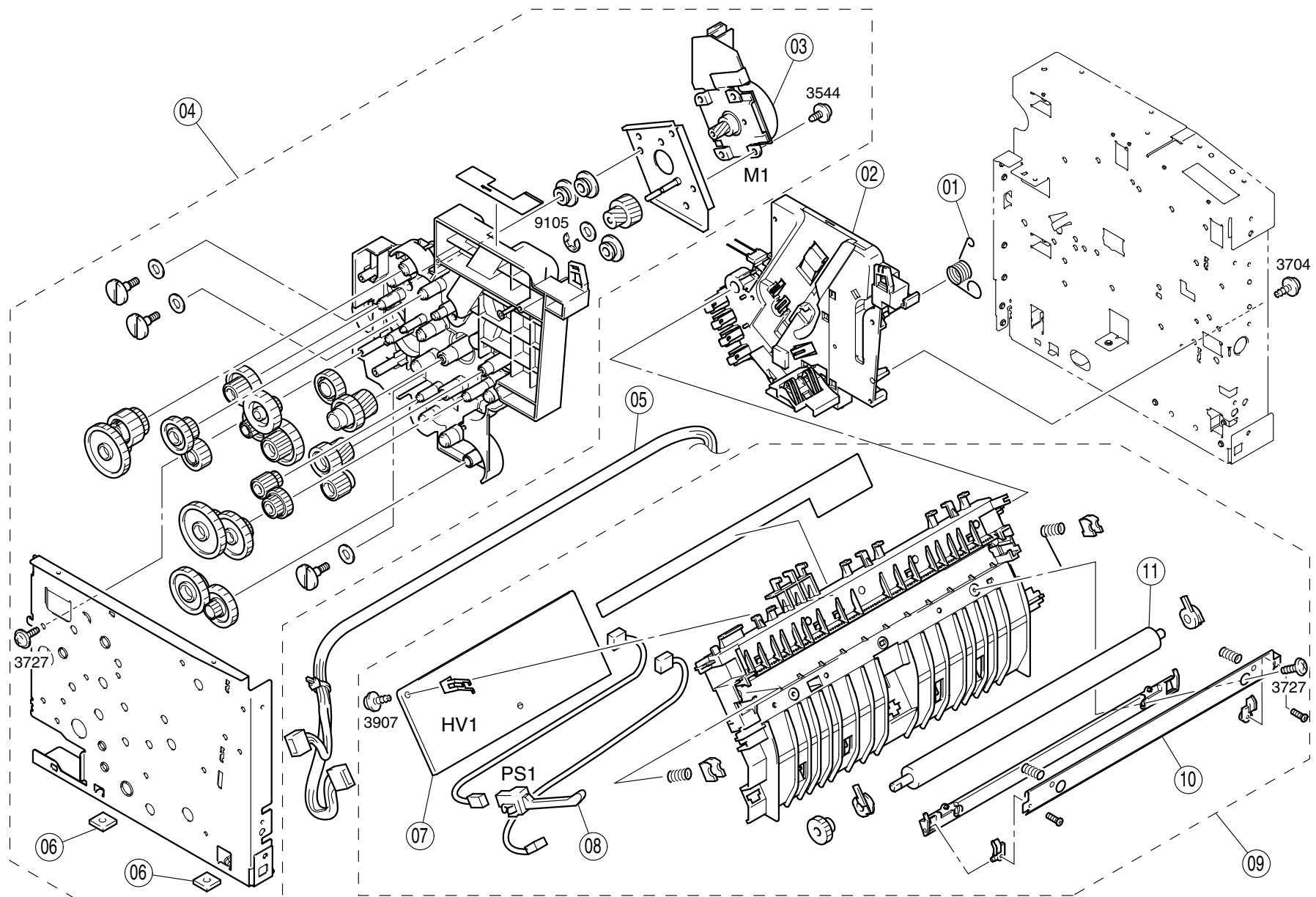

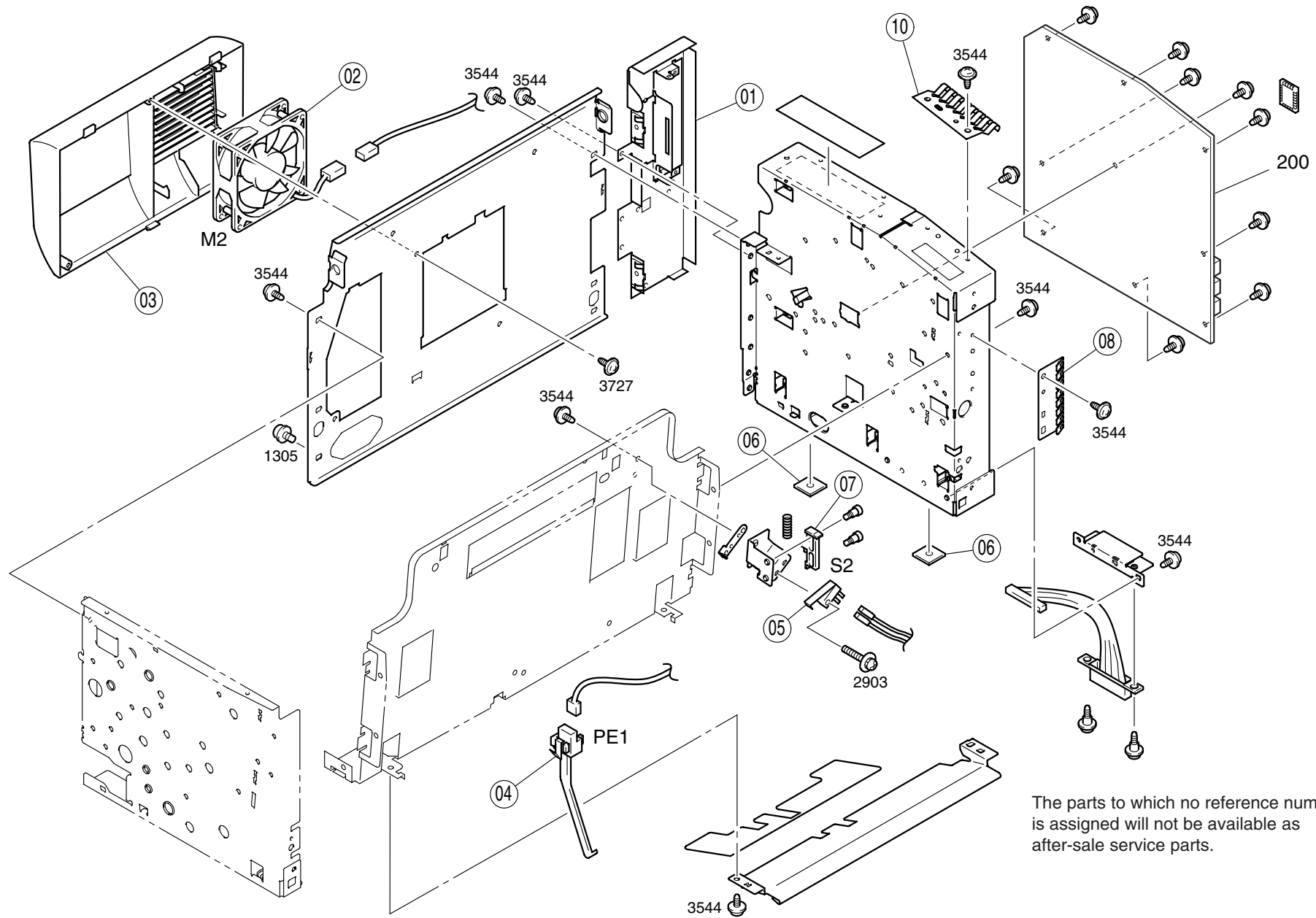

The parts to which no reference number is assigned will not be available as after-sale service parts.

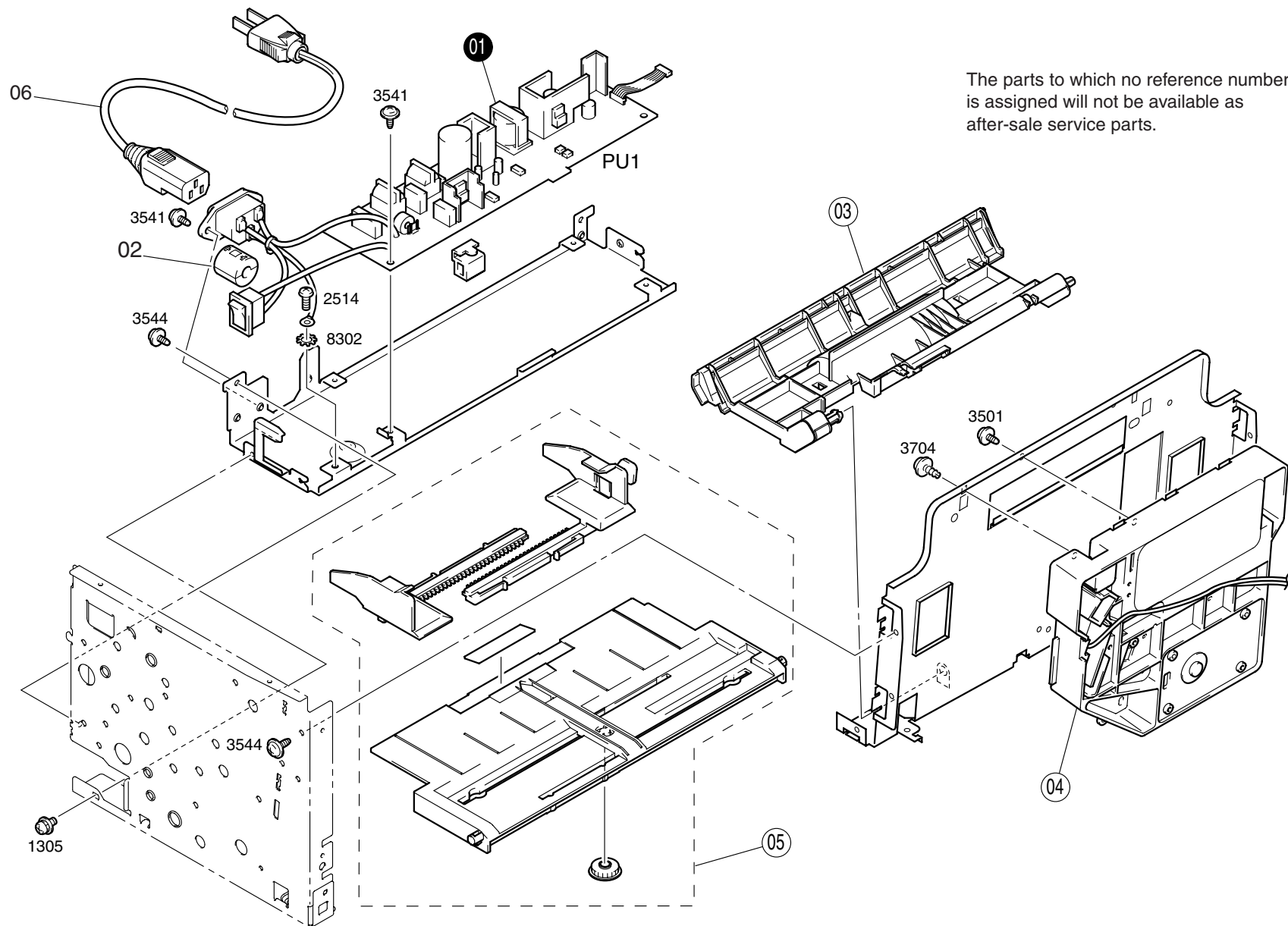

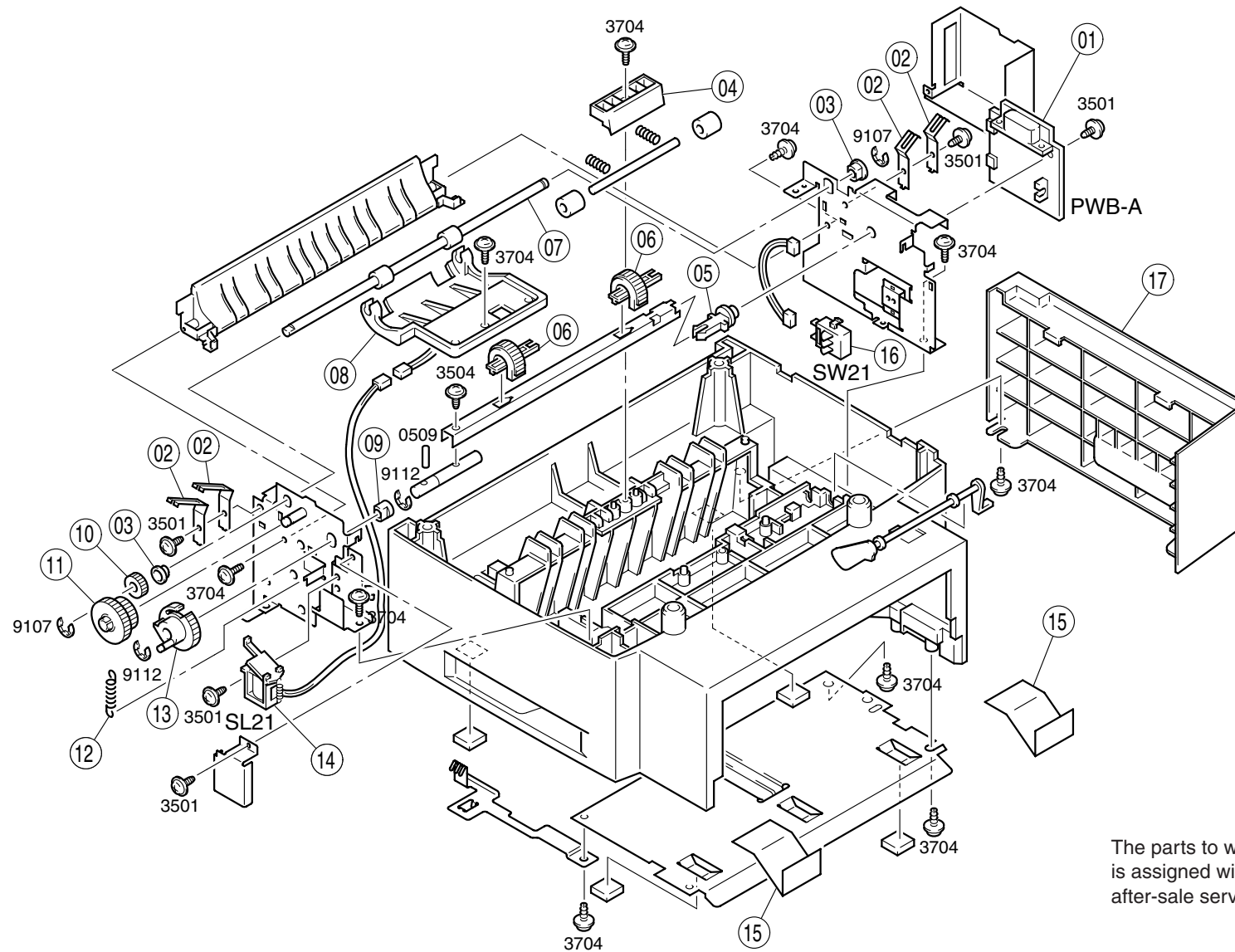

The parts to which no reference number is assigned will not be available as after-sale service parts.

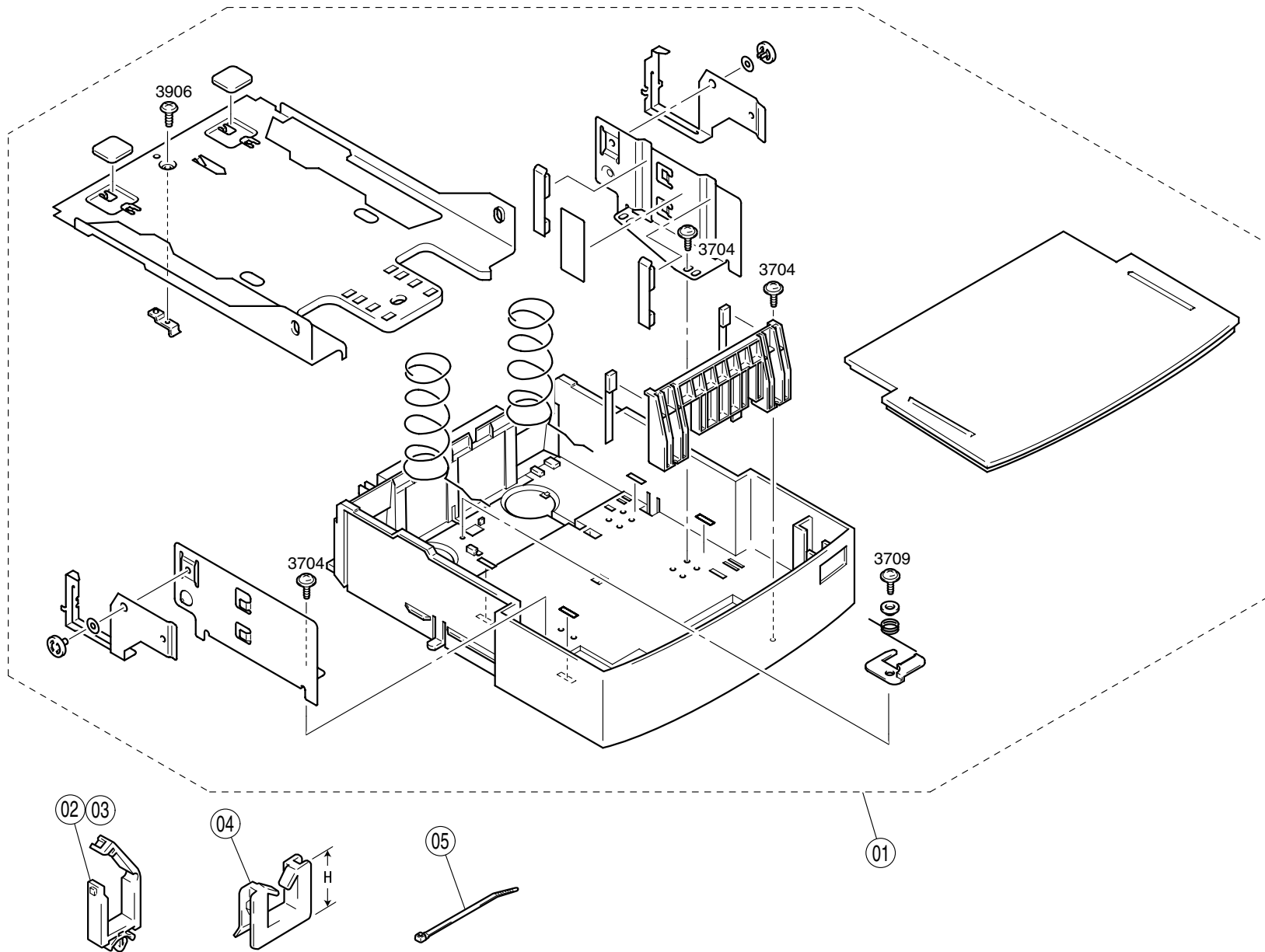

Free Manuals Download Website

<http://myh66.com>

<http://usermanuals.us>

<http://www.somanuals.com>

<http://www.4manuals.cc>

<http://www.manual-lib.com>

<http://www.404manual.com>

<http://www.luxmanual.com>

<http://aubethermostatmanual.com>

Golf course search by state

<http://golfingnear.com>

Email search by domain

<http://emailbydomain.com>

Auto manuals search

<http://auto.somanuals.com>

TV manuals search

<http://tv.somanuals.com>