

SERVICE MANUAL

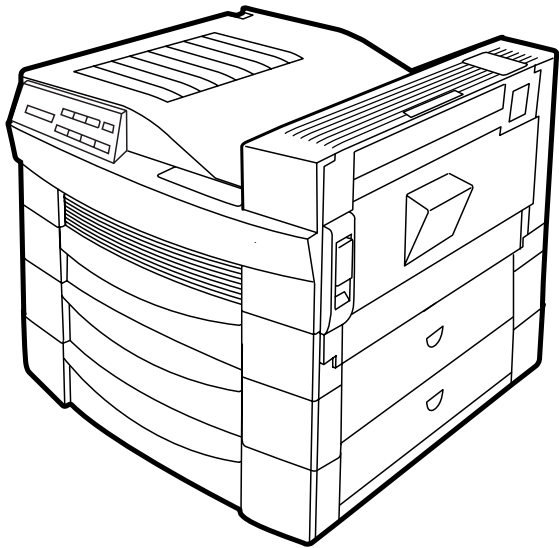

Laser Printer

EPSON EPL-N2700



EPSON®

SEPG98006

Notice:

- All rights reserved. No part of this manual may be reproduced, stored in a retrieval system, or transmitted in any form or by any means, electronic, mechanical, photocopying, recording, or otherwise, without the prior written permission of SEIKO EPSON CORPORATION.
- The contents of this manual are subject to change without notice.
- All effort have been made to ensure the accuracy of the contents of this manual. However, should any errors be detected, SEIKO EPSON would greatly appreciate being informed of them.
- The above notwithstanding SEIKO EPSON CORPORATION can assume no responsibility for any errors in this manual or the consequences thereof.

EPSON is a registered trademark of SEIKO EPSON CORPORATION.

General Notice: Other product names used herein are for identification purpose only and may be trademarks or registered trademarks of their respective owners. EPSON disclaims any and all rights in those marks.

Copyright © 1996 SEIKO EPSON CORPORATION. Printed in Japan.

PRECAUTIONS

Precautionary notations throughout the text are categorized relative to 1) Personal injury and 2) damage to equipment.

DANGER Signals a precaution which, if ignored, could result in serious or fatal personal injury. Great caution should be exercised in performing procedures preceded by DANGER Headings.

WARNING Signals a precaution which, if ignored, could result in damage to equipment.

The precautionary measures itemized below should always be observed when performing repair/maintenance procedures.

DANGER

1. ALWAYS DISCONNECT THE PRODUCT FROM THE POWER SOURCE AND PERIPHERAL DEVICES PERFORMING ANY MAINTENANCE OR REPAIR PROCEDURES.
2. NO WORK SHOULD BE PERFORMED ON THE UNIT BY PERSONS UNFAMILIAR WITH BASIC SAFETY MEASURES AS DICTATED FOR ALL ELECTRONICS TECHNICIANS IN THEIR LINE OF WORK.
3. WHEN PERFORMING TESTING AS DICTATED WITHIN THIS MANUAL, DO NOT CONNECT THE UNIT TO A POWER SOURCE UNTIL INSTRUCTED TO DO SO. WHEN THE POWER SUPPLY CABLE MUST BE CONNECTED, USE EXTREME CAUTION IN WORKING ON POWER SUPPLY AND OTHER ELECTRONIC COMPONENTS.

WARNING

1. REPAIRS ON EPSON PRODUCT SHOULD BE PERFORMED ONLY BY AN EPSON CERTIFIED REPAIR TECHNICIAN.
2. MAKE CERTAIN THAT THE SOURCE VOLTAGES IS THE SAME AS THE RATED VOLTAGE, LISTED ON THE SERIAL NUMBER/RATING PLATE. IF THE EPSON PRODUCT HAS A PRIMARY AC RATING DIFFERENT FROM AVAILABLE POWER SOURCE, DO NOT CONNECT IT TO THE POWER SOURCE.
3. ALWAYS VERIFY THAT THE EPSON PRODUCT HAS BEEN DISCONNECTED FROM THE POWER SOURCE BEFORE REMOVING OR REPLACING PRINTED CIRCUIT BOARDS AND/OR INDIVIDUAL CHIPS.
4. IN ORDER TO PROTECT SENSITIVE MICROPROCESSORS AND CIRCUITRY, USE STATIC DISCHARGE EQUIPMENT, SUCH AS ANTI-STATIC WRIST STRAPS, WHEN ACCESSING INTERNAL COMPONENTS.
5. REPLACE MALFUNCTIONING COMPONENTS ONLY WITH THOSE COMPONENTS BY THE MANUFACTURE; INTRODUCTION OF SECOND-SOURCE ICs OR OTHER NON-APPROVED COMPONENTS MAY DAMAGE THE PRODUCT AND VOID ANY APPLICABLE EPSON WARRANTY.

Safety Information

To prevent accidents during a maintenance procedure, strictly observe the Warnings and Cautions. Do not do anything that is dangerous or not within the scope of this document.

Do not do anything that is dangerous even if not specifically described in this manual. In addition to the descriptions below and those given in this manual, there are many situations and circumstances that are dangerous. Be aware of these when you are working with the printer.

Power Supply and Other Electrical Devices

Before starting any service procedure, switch off the printer power and unplug the power cord from the wall outlet. If you must service the printer when the power is applied, be aware of the potential for electrical shock and do all tasks by following the procedures in this manual.



Do not touch any live part unless you are instructed to do so by a service procedure.

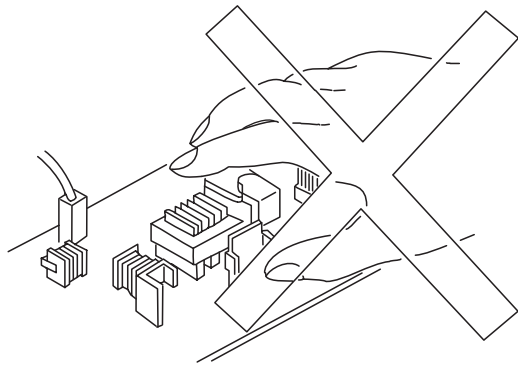

Mechanical Components

If you service gear or roll, manually rotate a drive assembly. Never hand-rotate or stop the drive assembly while the main motor is rotating.

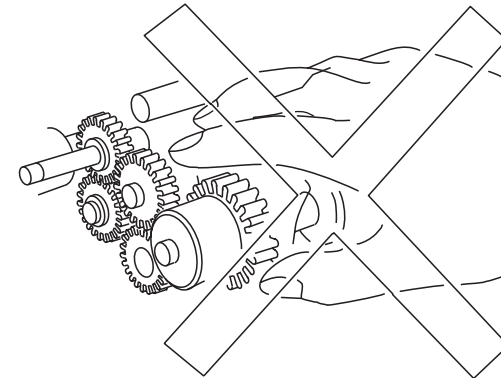

Laser Beam



The laser beam used for exposing process during printing is a very powerful, straight, narrow beam of light that produces extreme heat at its focal point. The laser beam in this printer is invisible. Although you cannot see the beam, it can still cause severe damage. Direct eye exposure to the laser beam may cause eye injury or blindness. Never place a mirror or a reflective tool or object in the laser beam path.

To avoid permanent eye damage, follow these directions;

- Before starting any service procedure, switch off the printer power and unplug the power cord from the wall outlet.
- Do not disassemble the ROS Assembly or any laser component that displays Laser Warning Sticker.
- Use caution when you are working around the ROS Assembly or when you are performing laser related repair procedures.
- Do not disassemble the printer in such a way that the laser beam can exit the printer engine during a print cycle.

Safety Component

Make sure fuses, interlock switches, covers, and panels are all functioning properly after you have reinstalled or replaced them.

Warning/Caution Label

WARNING and CAUTION labels are stuck on dangerous parts in the printer to make you aware of the potential dangers that are present when you are working with those parts.

PREFACE

This manual describes basic functions, theory of electrical and mechanical operations, maintenance and repair procedures of EPSON EPL-N2700. The instructions and procedures included herein are intended for the experienced repair technicians, and attention should be given to the precautions on the preceding page. The chapters are organized as follows:

CHAPTER 1. PRODUCT DESCRIPTIONS

Provides a general overview and specifications of the product.

CHAPTER 2. OPERATING PRINCIPLES

Describes the theory of electrical and mechanical operations of the product.

CHAPTER 3. DISASSEMBLY AND ASSEMBLY

Describes the step-by-step procedures for disassembling and assembling the product.

CHAPTER 4. ADJUSTMENTS

Provides Epson-approved methods for adjustment.

CHAPTER 5. TROUBLESHOOTING

Provides the step-by-step procedures for troubleshooting.

CHAPTER 6. MAINTENANCE

Provides preventive maintenance procedures and the lists of Epson-approved lubricants and adhesives required for servicing the product.

APPENDIX

Provides the following additional information for reference:

- *Connector Pin Assignment*
- *Electrical Circuit Board Component Layout*
- *Exploded Diagram*
- *Electrical Circuit Board Schematic*

Revision Status

Revision	Issued Date	Description
0	January 26, 1999	Preliminary version

Contents

Product Description

OVERVIEW	12
BASIC SPECIFICATIONS	13
CONTROLLER SPECIFICATIONS	13
Configuration	14
ENGINE SPECIFICATIONS	15
PAPER SPECIFICATIONS	17
Process Specifications	20
Paper Specifications	20
RELIABILITY, DURABILITY, AND MAINTAINABILITY	22
ENVIRONMENTAL CONDITION FOR STORAGE AND TRANSPORTATION (Including Consumables)	24
Electrical Specifications	25
SAFETY APPROVAL	26
CONSUMABLES	27
External Interface Specifications	28
Host Interface Usage Configurations	28
Parallel Interface	29
Serial Interface	29
Ethernet I/F	30
Type-B I/F	31
Panel Operation	32
Control Panel	32
Panel Settings	34
Setting Items	34
User Setting Items which are not include in the Setting Menu	38
Setting Item Description	38
One-Touch Setting	41
Special Functions	41
Maintenance Mode	43
Engine Status Sheet	44

List of Data Controlled by the Engine Status Sheet and Controlling Method	47
--	----

Dimensions and Weight	48
------------------------------------	----

Operating Principles

Printer Mechanism Operating Principles	51
General Description of Each Section	52
Gear/Roller Location	53
Electrical Component Layout	54
Switches and Sensors	55
Paper Feeding Section	56
MP Tray	56
Cassette 1	60
Paper Feed	65
Printhead Unit (Exposure Section)	66
Print Process Sequence	67
Imaging Cartridge	68
Part Names and Functions of the Imaging Cartridge	68
Charging Section	69
Development Section	69
Transfer Section	71
Fusing Section	72
Paper Exit Section	74
Detection whether New or Used Imaging Cartridge	75
Right Door Interlock Switch	75
Electrical Circuit Operating Principles.	76
System Layout	76
Drive Section	76
Electrical Section	77
Main Circuit (Video Controller)	78
Main Component in the Main Circuit Board	78

Troubleshooting

Overview	80
Printer Messages	80
Message List	80
Message Descriptions	82
Service-call Error	83
Engine Related Error	83
Controller Related Error List	84
Clearing the Service-call Error	85
Adding on RAM	85
Troubleshooting	85
The Printer will not Start	85
The Printer will no Print.	86
Image Quality Problems	86

Disassembly/Assembly

Overview	88
Precaution	88
Tools	88
Small Parts	89
Disassembly Procedure	91
ROM DIMM Removal	92
Paper Eject Sensor Removal	93
1st Cassette Paper Take-up Roller Removal	94
Transfer Section	95
Transfer Roller Removal	95
Transfer Unit Removal	96
Timing Roller Front Sensor Removal	96
Timing Clutch Removal	97
Timing Roller Removal	98
Internal Cooling Fan Removal	99
Separating the Printer	99
Rear Cover Removal	100
Transport Motor Removal	100
I/C Drive Motor Removal	101
1st Cassette Size Sensor Removal	101
Paper Size Sensor Removal	102
Top Cover Removal	102

Toner Empty Sensor Removal	103
Main Circuit Board Removal	104
Engine Controller Board Removal	105
Power Supply Unit Cooling Fan Removal	107
High Voltage Unit Removal	108
Front Cover Removal	109
Control Panel Removal	109
Printhead Unit Removal	110
Power Supply Unit Removal	112
Fusing Section	113
Fuser Unit Removal	113
Heater Lamp Replacement	114
Fusing Roller Thermistor / Thermostat / Temperature Fuse Removal	115
Upper Paper Separator Finger Removal	118
Lower Paper Separator Finger Removal	119
Upper Paper Eject Roller Removal	119
Lower Paper Eject Roller Removal	120
Drive Unit Removal	121
1st Cassette Paper Take-up Solenoid (SL1) Removal	123
1st Cassette Set Sensor Removal	123
1st Cassette Paper Empty Sensor Removal	123
1st Cassette Paper Near Empty Sensor Removal	124
2nd Cassette Disassembly	125
Paper Take-up Roller Removal	125
2nd Cassette Paper Empty Sensor Removal	126
2nd Cassette Paper Near Empty Sensor Removal	126
Paper Size (Paper Size Switch) Sensor Removal	127
2nd Cassette Control Board (PWB-A) Removal	127
2nd Cassette Paper Take-up Solenoid Removal	128
2nd Cassette Right Door Set Sensor Removal	129
Updating the Firmware	130
Updating the Program ROM	130
Error Indications and Measures	130
Copying the DIMM Module	132

Adjustment

Maintenance

Overview	136
Maintenance by Users	136
Replacement of Consumable Items	136
Maintenance by Servicers	137

Appendix

Connector Summary	139
Component Layout	141
Exploded Diagrams	142
Housing	142
Frames	144
Fusing Section (A)	146
Fusing Section (B)	148
Transport Section (A)	150
Transport Section (B)	152
Electrical Components	154
Paper Take-up Section	156
Drive Section	158
Paper Tray Unit	160
Circuit Diagrams	162

CHAPTER

1

PRODUCT DESCRIPTION

1.1 Overview

The EPL-N2700 is a business-oriented page printer making the most use of the laser diode and the electrical photo technology. The main feature of the printer are as follows:

ENGINE FEATURES

- High-speed, highly reliable A3 Engine (Maximum duty cycle is 100,000 sheets per month).
- Resolution is 600 dpi, with a printing speed of 27 ppm when feeding A4 from Cassette 1. (26 ppm for Letter)
- Standard paper capacity is 750 sheets, 250 in the MP tray and 500 in the Cassette 1.
- Holds optional cassettes to increased paper loading capacity:
 - One Lower Cassette (500 sheets) + Large Capacity Paper Cassette (2500 sheets for A4 of Letter)
 - Up to three Lower Cassettes
- Wide variety of options
 - Duplex unit
 - 5-bin Multibin unit
 - 10-bin Multibin unit.

CONTROLLER FEATURES

- A new CPU (166MHz, VR4310) used for a high-speed controller
- Use of SDRAM DIMM for an optional RAM will expand the standard 16-MB memory up to 256 MB.
- Three types of standard interface

- IEEE I284 based parallel interface (supports ECP)
- RS-232C serial interface
- Ethernet Interface (100/10Base-TX)
- One slot for Type B interface card
- Supports Enhanced MicroGray

SOFTWARE

- Supported Emulation
 - ESC/Page *1
 - PCL5e
 - ESC/P2
 - FX
 - 1239X
 - EPSON GL2
 - PostScript 3 (Optional item provided on a ROM DIMM board)
- Rewriting the Flash DIMM
Flash ROM in Slot A and program slot can be rewritten.

*1. Unintended for users

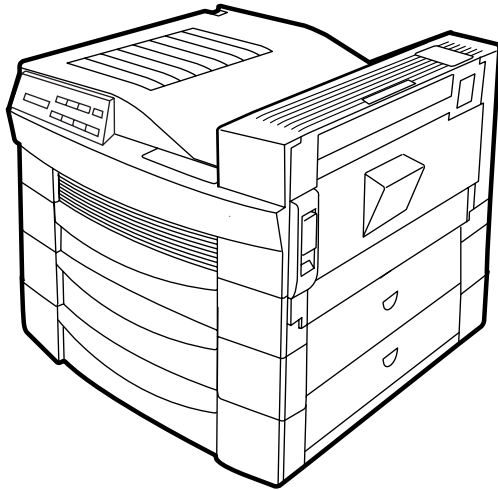

Figure 1-1. Exterior View of the EPL-N2700

1.2 Basic Specifications

This section describes the basic specifications of the EPL-N2700.

1.2.1 Controller Specifications

CPU

VR4310 / 166MHz

RAM

- Standard 16MB (on-board)^{*1}
- Optional 8MB^{*2}/16MB^{*2}/32MB/64MB/128MB/
256MB^{*3} (SDRAM type, 1 slot)
Can be expanded up to 256MB.

ROM

- Font: 2Mbytes (on-board)
- Program: 4Mbytes (on Flash ROM-DIMM board)
- Expansion ROM: 3 ROM-DIMM slots (Can be removed/
installed at power on only)
Available for NLSP FONT DIMM and
PostScript 3 DIMM

*1. 8MB (TBD) is allocated for the program area. The RAM Check at startup shows the attached memory size, while the status sheet shows the size with the program code size deducted as well as the attached memory.

*2. Not mentioned in any catalog nor specifications, since they are hardly distributed.

*3. Availability of 256MB RAM, which may be distributed in future, will be determined after the printer is in market.

INTERFACES

- Standard interface:
 - Parallel interface:
Bidirectional parallel I/F (B type connector)
(IEEE-1284 compliant / Compatibility, Nibble and ECP mode)
 - Serial interface:
RS-232C
Ethernet 100/10BaseTX
- Optional interface: Type-B interface slot (1 slot)

CONTROL PANEL

Consists of the 8 push-button switches, 6 LED lamps, and 20-digit LCD

INSTALLATION FORMAT

Direct attachment

OTHER FEATURE

Does not support mechanism controller.

1.2.2 Configuration

The following configuration set on the controller varies according to the destination. (See Table 1-1.) Settings are made in factory using the jumper resistance.

Table 1-1. Configuration Classification

Version (Destination)	Default for Paper Size	NLSP (Slot C)	Chinese character fonts (Slot C)
South American	Letter	Unsupported	Unsupported
European, Pacific, South American, Korean	A4	Unsupported	Unsupported
North European	A4	Supported	Unsupported
Taiwanese	A4	Unsupported	Unsupported

1.2.3 Engine Specifications

PRINTING METHOD

Semiconductor laser beam scan + dry-powdered single-component magnetic toner electro-photographic printing

RESOLUTION

600DPI

PRINTING SPEED

Table 1-2. Printing Speed (Sheet / Minute)

Paper Size	Single Print		Duplex Print	
	MP Cassette	Cassette 1	MP Cassette	Cassette 1
A4 (SEF)*	26.0	27.0	16.9	17.0
A3 (LEF)**	14.1	14.2	8.5	8.5
A5 (SEF)	33.0	–	19.7	–
LTR (SEF)	25.4	26.0	16.7	16.7

SEF: Short Edge First, LEF: Long Edge First

NOTE: For non-standard size paper, the printer prints at a lower speed since the printer automatically performs cleaning.

FIRST PRINT

Table 1-3. First Print

Paper Size	Single Print		Duplex Print	
	MP Cassette	Cassette 1	MP Cassette	Cassette 1
A4 (LEF*)	11.2	11.2	20.1	20.1
A3 (SEF**)	13.3	13.3	22.4	22.4
A5 (LEF)	10.9	–	17.7	–
LTR (LEF)	11.3	11.3	20.3	20.3

*SEF: Short Edge First, **LEF: Long Edge First

WARM-UP TIME

60 seconds or less (at 23 °C / at rated voltage)

PAPER SOURCES

- Standard
 - MP (Multi Purpose) cassette
 - Cassette 1 (Universal Paper Cassette)
- Optional
 - Lower Cassette Unit (Universal Cassette)
 - Large Capacity Lower Cassette

NOTE: Up to 3 optional Paper Cassette Units can be installed.

See Table 1-4 for paper source specifications.

Table 1-4. Paper Supply / Paper Size / Capacity

Paper Source / Capacity		Paper Size Available	Paper Thickness Available	
Standard	MP Tray	250 sheets	<ul style="list-style-type: none"> Standard size paper within the size of: A5(LEF^{*1}) - A3(LEF^{*2}) Half Letter - Ledger(SEF) (8.5" x 5.5") (11" x 17") Custom size paper Any size of paper within the range of: Width: 86 - 297 mm Length: 140 - 432 mm 	Normal paper: 60 - 90g/m ² (16 - 24lb)
		20 sheets	<ul style="list-style-type: none"> Envelopes (Monarch, C10, DL, C5, C6) Labels, OHP sheet, Thick paper, Letterhead 	<ul style="list-style-type: none"> Special paper (Labels, OHP sheet) Normal paper: 60 - 90g/m² (16 - 24lb) Thick paper: 90 - 163 g/m²
	Cassette 1	500 sheets	<ul style="list-style-type: none"> A3(SEF), A4(LEF), Ledger (SEF) (11" x 17") Legal (SEF) (14" x 8.5") Letter (LEF) (11" x 8.5") G.Letter (LEF) (10.5" x 8") 	Normal paper: 60 - 90g/m ² (16 - 24lb)
Option	Lower Cassette (500-sheet cassette unit ^{*3})	500 sheets	<ul style="list-style-type: none"> A3(SEF), A4(LEF), Ledger (SEF) (11" x 17") Legal (SEF) (14" x 8.5") Letter (LEF) (11" x 8.5") G.Letter (LEF) (10.5" x 8") 	Normal paper: 60 - 90g/m ² (16 - 24lb)
	Large Capacity Lower Cassette	2500 sheets ^{*4}	<ul style="list-style-type: none"> A4 (LEF) Letter (LEF) (11" x 8.5") 	Normal paper: 60 - 90g/m ² (16 - 24lb)

*1: Set paper with the Long Edge First.

*2: Set paper with the Short Edge First

*3: Up to 3 optional Lower Cassette Units can be installed.

*4: With 80g/m² paper

□ Number of sheets loaded

- Standard: 750 sheets (250 + 500)
- With options: Up to 3,750 sheets in total. (Standard: 250 + 500, Optional 500 + 2,500)

1.2.4 Paper Specifications

See Table 1-5 for the paper sources and their paper availability.

Table 1-5. Paper Sources and their Paper Availability

	Type	Size mm (inch)	North America			Europe			Duplex Unit
			MP Cassette	Cassette 1	Large Capacity Lower Cassette	MP Cassette	Cassette 1	Large Capacity Lower Cassette	
				500 -Sheet Lower cassette			500-Sheet Lower cassette		
Normal Paper	A3	297 x 420	AC	AM		AA	AM		AC
	A4 (LEF)	210 x 297	AC	AM		AA	AM	AA	AC
	A5 (LEF)	148 x 210	AC			AA			AC
	JIS-B5 (LEF)	182 x 257	AC			AC			AC
	ISO-B5 (LEF)		AC			AA			AC
	LTR (LEF)	215.9 x 279.4 (8.5 x 11")	AA	AM	AA	AA	AM	AA	AC
	HLT (LEF)	139.7 x 215.9 (5.5 x 8.5")	AA			AC			AC
	LGL	215.9 x 355.6 (8.5 x 14")	AA	AM		AA	AM		AC
	EXE (LEF)	184.15 x 266.7 (7.25 x 10.5")	AA			AC			AC
	GLG	215.9 x 330.2 (8.5 x 13")	AA			AC			AC
	GLT (LEF)	203.2 x 266.7 (8 x 10.5")	AA	AM		AC	AM		AC
	B		AA	AM		AC	AM		AC
	F4	210 x 360	AC			AA			AC
	Nonstandard	330 x 275	AC			AC			
special paper	MON	98.43 x 190.5 (37/8 x 7½")	AC			AC			
	C10	104.78 x 241.3 (41/8 x 9½")	AC			AC			
	DL	110 x 220	AC			AC			
	C5	162 x 229	AC			AC			
	C6	114 x 162	AC			AC			

NOTE: AA: Available (Automatic paper size detection is supported for MP cassette.)

AM: Available (Manual paper size detection is supported. Paper size is set with dials.)

AC: Available (Paper size is set though the control panel.)

CONSUMABLES AND OPTIONS

Imaging Cartridge

SUPPORTED PAPER SIZES

- MP Cassette:
 - Width = 86 to 297 mm (3.39 to 11.7 ")
- Cassette 1:
 - Width = 215.9 to 297 mm (3.9 to 11.7 ")
 - Length = 203.2 mm to 431.8 mm (8 to 17 ")
 - Available paper size = A3 (SEF), A4 (LEF), Letter (SEF), Letter (LEF), G.Letter (LEF)
- Lower Cassette: Same as for the Cassette 1.
- Large Capacity Lower Cassette:
 - Available paper size = A4(LEF), Letter(LEF)

PAPER FEED ALIGNMENT

Center alignment for all paper sizes

PAPER EJECTION

- Standard: Face-down ejection only
Holds up to 500 sheets (75 g / m²)
- With options:
See Table 1-6 and Table 1-7 for paper ejection capacity with the optional 5-bin/10-bin Unit installed.

- With a 5-bin Unit installed:

Table 1-6. Paper Ejection Capacity with 5-bin Unit

Paper Type	Bin 1		Bin 2 - 4	Bin 5
	Normal	Shifting		
Normal paper (60 - 90 g / m ²)	250 sheets	250 sheets	50 sheets	100 sheets
Envelopes, OHP sheets Thick paper (90 - 163 g / m ²)	10 sheets (TBD)	-	-	-

NOTE:Each bin is equipped with the full stack sensor.

- With a 10-bin unit installed:

Table 1-7. Paper Ejection Capacity with 10-bin Unit

	Bin 1	Bin 2 - 20
Normal paper (60 - 90 g / m ²)	200 sheets	200 sheets
Envelopes, OHP sheets Thick paper (90 - 163 g / m ²)	10 sheets (TBD)	-

NOTE:Each bin is equipped with the full stack sensor.

POWER CONSUMPTION

- Printer Main Body: See Table 1-8.

Table 1-8. Power Supply Specification

Item	100V Model	200V Model
Input Voltage	120V \pm 10% (90 to 132V)	220 - 240V \pm 10% (198 to 264V)
Rated Frequency	50 - 60Hz \pm 3Hz	50 - 60Hz \pm 3Hz
Rated Current	11.5 A	6.0 A
Power Consumption	<ul style="list-style-type: none"> • Maximum: 1050W • Continuous printing: 750W • Stand-by (Heater ON): 200W • Stand-by (Heater OFF): 45W 	

- Large Capacity Paper Cassette Unit

DC24 V and DC5 V are supplied from the printer.

- Average consumption current:
1.0 A or less (24V)
0.5 A or less (5V)
- Peak current:
1.5 A or less (24V)
0.5 A or less (5V)

- Lower Cassette Unit:

DC24 V and DC5 V are supplied from the printer.

- Average consumption:
TBD (24V)
TBD (5V)

- 10-bin Unit:

DC24 V and DC5 V are supplied from the printer.

- Average consumption current:
1.3 A or less (24V)
0.5 A or less (5V)
- Power consumption:
32 W or less (TBD)

- 5-bin Unit

DC24 V and DC5 V are supplied from the printer.

- Average consumption current:
1.0 A or less (24V)
0.3 A or less (5V)
- Power consumption:
24 W or less (TBD)

NOISE:

- Stand-by: Approximately 38.0 dB (A) or less
- Operating: Approximately 55.0 dB (A) or less

OZONE DENSITY

0.1 ppm or less

TOXICITY

OPC, toner, and plastic materials are all nontoxic.

1.2.5 Process Specifications

- Printing system: Dry single-component toner electrophotographic process
- Exposing source: Semi-conductor laser beam
- Exposed object: OPC drum
- Charging system: Rotating charging brush system
- Developing system: Exposed area developing system
- Toner: Single-component nonmagnetic toner
- Transfer system: Roller transfer system
- Fixing system: Heat roller system
- Density control: Variable developer bias (can be set by user)

1.2.6 Paper Specifications

PAPER TYPE

- Standard paper: Xerox 4024 DP paper 20lb (75 g/m²)
- Normal paper: 60 g/m² - 90 g/m² (16 lbs - 24 lbs)
Copy paper, bond paper, and recycled paper that are generally used
- Special paper: Labels, OHP film, Color paper, Thick paper (90 - 157 g/m²), DTP paper, and Letterhead

NOTE: Do not use the following papers in this printer. Use of any of the following papers will cause the printer malfunctions such as print problem and paper jam, and also damage the printer.

- Carbon paper, "non-carbon" paper
- Thermal paper, pressure-sensitive paper, Acidic paper
- Paper already printed on by thermal-transfer printer or ink jet printer
- Thin or thick paper (exceeding the specification)
- Wet (damp) paper
- Paper with coated or processed color surface
- Paper with extra smooth or extra rough surface
Paper whose smoothness on the both sides are largely different
- Paper with perforation or binder holes
- Folded, curled, or torn paper
- Paper of irregular shape
Paper cut at off-angle
- Label sheets that peel too easily
- Paper with clips, staples, glue, and so on.
- Paper exclusively designed for ink jet printers (super fine paper, glossy paper, glossy film, and so on.)
- Transparency film designed for color photo copier or color laser page printer.
- Paper already printed on with a color/monochrome laser printer or photo copier.
- Paper pasted together



Use of illustrated postcard may leave paper debris on the paper loading roller, which causes the printer to feed paper improperly. If this problem occurs, clean the paper loading roller. (Refer to Chapter 6 "Maintenance" for cleaning method.)

PAPER PATH AVAILABILITY

Table 1-9. Paper Path Availability

	Standard paper	Normal paper	Special Paper				
			OHP sheet	Postcard	Label	Thick paper	Envelope
MP Cassette	RF	R	P	P	P	P	P
Cassette 1	RF	R	N	N	N	N	N
500-sheet lower cassette unit	RF	R	N	N	N	N	N
Large Capacity Lower Cassette	RF	R	N	N	N	N	N
Duplex Unit	RF	R	N	N	N	N	N

RF: Reliable feeding and good image quality.

R: Reliable feeding and good image quality, but limited to paper generally available.

P: Possible, but limited to paper generally available.

N: Not supported

PRINTABLE AREA

- Printable area: TBD
- Guaranteed print area: Area other than 4 mm inward from each edge. (See Figure 1-2.)

NOTE: Guaranteed printable area may vary depending on the printer mode.

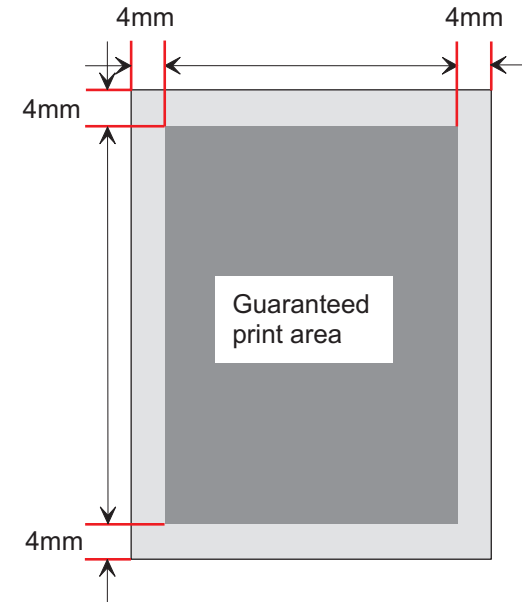

Figure 1-2. Guaranteed Printable Area

1.2.7 Reliability, Durability, And Maintainability

MPBF

60,000 sheets (For single-side print)

NOTE: MPBF is an average number of sheets printed between failures, where "failure" indicates a condition that requires part replacement or that cannot be corrected by user.

PRINT VOLUME

- Maximum = 100,000 sheets / month
- Average = 10,000 sheets / month

MTBF

3,000 H (10 months) or more

PAPER FEED RELIABILITY

When standard paper is used in the standard environment:

Table 1-10. Paper Feed Reliability

	Single-side Print	Duplex print
Jam rate *1	1/2000 or less	1/1000 or less
Feed failure	1/2000 or less	TBD
Multiple paper feeds	1/500 or less	TBD
Paper wrinkle	1/1000 or less	1/500 or less
Edge bent	1/1000 or less for 1C or more (Less than 1C is disregarded.) *2	1/500 or less

*1: Multiple feed is not included.

*2: 1C means 1 corner bent by 1 mm or less.

PRINT POSITION ACCURACY

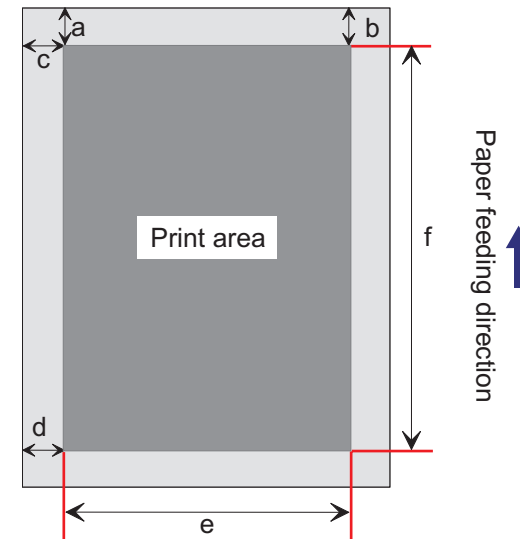

Table 1-11. Print Position Accuracy

Single-side print	Main scan direction (c)	±2.mm
	Sub scan direction (a)	TBD
Duplex print	Main scan direction (c)	±3.mm
	Sub scan direction (a)	TBD

SKEW

Table 1-12. Paper Skew

Print mode	Direction	A4 (LEF)	A3 (SEF)
Single-side print	Main scan direction (c – d)	±2.mm TBD	TBD
	Sub scan direction (a – b)	±1.5.mm TBD	
Duplex print	Main scan direction (c – d)	±3.mm TBD	TBD
	Sub scan direction (a – b)	±2.5.mm TBD	

DURABILITY

5 years or 600,000 sheet, whichever comes first.

MAINTAINABILITY

MTTR* = Within 30 minutes (average)

*MTTR: Mean Time To Repair

EJECTION CURL

- Normal paper: ± 15 mm or less (TBD)
- OHP Sheet: ± 10 mm or less (TBD)

OPERATING CONDITIONS (INCLUDING CONSUMABLES)

- Temperature: 10 to 35°C
- Humidity: 15 to 85%RH (without condensation)
- Air Pressure (Altitude):760hPa or more (below 2500m)
- Tilt: 1° or less (rear ↔ back, right ↔ left)

- Ambient Illumination: 3000 lux or less
(Must avoid direct sunlight.)
- Space Requirement:

To ensure proper operation of the printer, sufficient open space must be left around printer, as indicated in Figure 1-3.

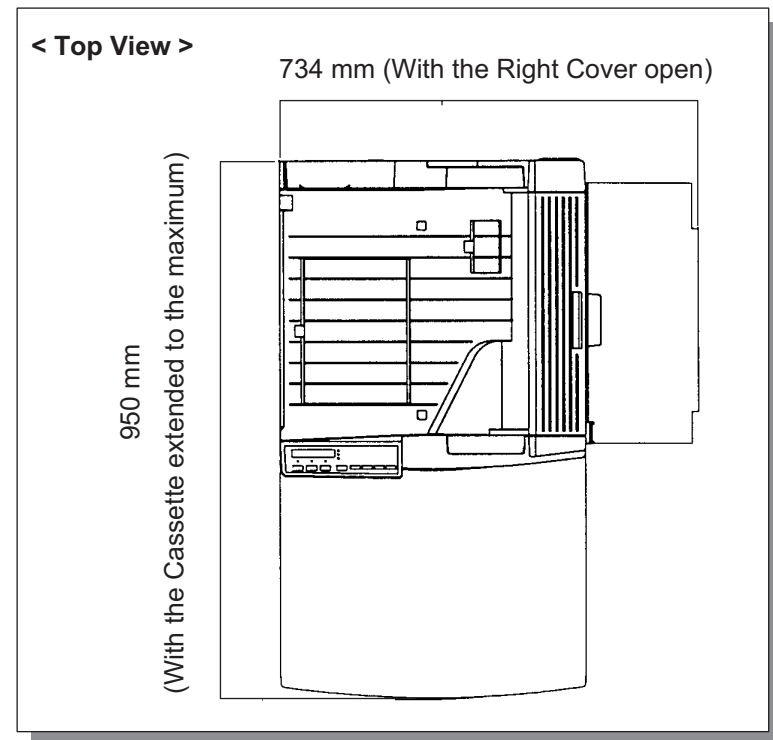
Figure 1-3. Space Requirement

1.2.8 Environmental Condition For Storage And Transportation (Including Consumable Items)

TEMPERATURE AND HUMIDITY

Table 1-13. Environmental Conditions - Main Unit

Item		Conditions	
Temperature	Normal	0 to 35°C	
	Extreme (1/30 of the total storage period)	High temperature	35 to 40°C *1
		Low temperature	-20 to 0°C
Humidity	Normal	30 to 80%RH	
	Extreme (1/30 of the total storage period)	High humidity	85 to 95%RH
		Low humidity	10 to 30%RH
Storage duration		Within 18 months from the production	

*1: 35 - 55 °C without an ET Cartridge

VIBRATION TOLERANCE

- Vibration: 5 to 100Hz / 100 to 5Hz
- Acceleration: 1G
- Sweep time: 10 minutes (one way)
- Direction: Three directions (X/Y/Z)
- Time: 60 minutes in each direction

AIR PRESSURE

74.0 to 101.3 kPa (Max. 555 - 760 mm Hg)

DROP TOLERANCE

No damage when tested in accordance with JIS Z0200-1987 level 1

- Direction: 1 corner, 6 sides, 3 edges

1.2.9 Electrical Specifications

AC LINE NOISE

- Pulse width: 50 to 1000 ns
- Pulse polarity: + / -
- Repetition: Asynchronous
- Modes: Common / Normal
- Voltage: 1KV
(Parts must be able to withstand 2KV without damage)

TRANSIENT OUTAGE

DIP 100% (at rated voltage - 10%) 1 cycle
(No abnormal print quality)

ELECTROSTATIC TOLERANCE

- Up to 10KV: No hard error, no user-nonrecoverable software error
- Up to 15KV: No damage to parts

SURGE CURRENT

1/2-cycle / Not above 50A

INSULATION RESISTANCE

10M Ω or more

DIELECTRIC STRENGTH

Insulation shall not break down when the following voltage is applied between primary circuit and chassis for 1 minute:

- 100V version: AC1000V
- 200V version: AC1500V

LEAKAGE CURRENT

3.5mA or less

1.2.10 Safety Approval

SAFETY REGULATION

Table 1-14. Safety Regulation

Model	Applicable Standard
100V version	<ul style="list-style-type: none"> • UL 1950 • CSA 22.2 No.950
200V version	<ul style="list-style-type: none"> • TUV-GS (EN60950) • CCIB • Complies with a safety regulation of the following countries: Russia, Singapore, Hong Kong (IEC950), Korea

SAFETY REGULATION (LASER RADIATION)

Table 1-15. Safety Regulation (Laser Radiation)

Model	Applicable Standard
100V version	FDA (NCDRH) Class 1
200V version	TUV-GS (EN60825)

EMC

Table 1-16. Safety Regulation (EMC)

Model	Applicable Standard
100V version	<ul style="list-style-type: none"> • CNS 13438 (for Taiwan) • FCC Part15 Subpart B Class B / CSA C108.8 Class B
200V version	<ul style="list-style-type: none"> • EC EMC directive 89/336/EEC • EN55022 Class B • EN61000-3-2 • EN61000-3-3 • EN50082-1 • AS/NZS 3548 class B (for Australia) • Korea EMC class B

POWER CONSUMPTION

In compliance with International Energy Star program

OTHERS

- Toner:
No effect on human health.
(In compliance with OSHA, TSCA, EINECS, worker safety laws and CSCL)
- OPC:
No effect on human health. (In compliance with OSHA)
- Ozone:
In compliance with UL478 5th Edition
- Materials:
In compliance with Swiss environment protection law (no CdS content)

1.2.11 Consumable Item

This printer's only consumable part is the Imaging Cartridge.

SPECIFICATIONS

Table 1-17. Imaging Cartridge Specifications

Name	Components	Life	Weight
ET Cartridge	<ul style="list-style-type: none"> • OPC Drum • Charging unit • Development unit • Single-component unmagnetic black toner 	Average: 15,000 pages *1 *2	Approximately 2.5 Kg

*1: Toner life is estimated based on continuous printing on A4 (LEF) size paper with 5% print coverage. Toner life will vary according to print coverage and printing method (continuous or intermittent, print density, and toner-save mode).

*2: If the number of photo conductor rotation reaches the values equivalent to 25,000 sheets (A4 LEF / continuous) before toner life-end is detected, the printer detects the condition as toner empty, same as the condition "ET Toner Cartridge has expired its life".

ENVIRONMENTAL CONDITION FOR STORAGE AND TRANSPORTATION

Table 1-18. Environmental Conditions - Consumables

Item		Conditions	
Temperature	Normal	0 to 35°C	
	Extreme (1/30 of the total storage period)	High temperature	35 to 40°C
		Low temperature	-20 to 0°C
Humidity	Normal	30 to 85%RH	
	Extreme (1/30 of the total storage period)	High humidity	85 to 95%RH
		Low humidity	10 to 30%RH

- Air Pressure: 74.0 - 101.3 KPa (555 to 760mmHg)
- Storage duration: Within 18 months from the production (unpacked)

DROP TEST

Same as for the printer main body.

VIBRATION

Same as for the printer main body.

1.3 External Interface Specifications

The EPL-N2700 supports the following interfaces.

- Bidirectional parallel I/F (standard)
- RS-232C serial (standard)
- Ethernet I/F
- Type-B interface slot (option)

See Figure 1-4 for the locations of the Interface slots.

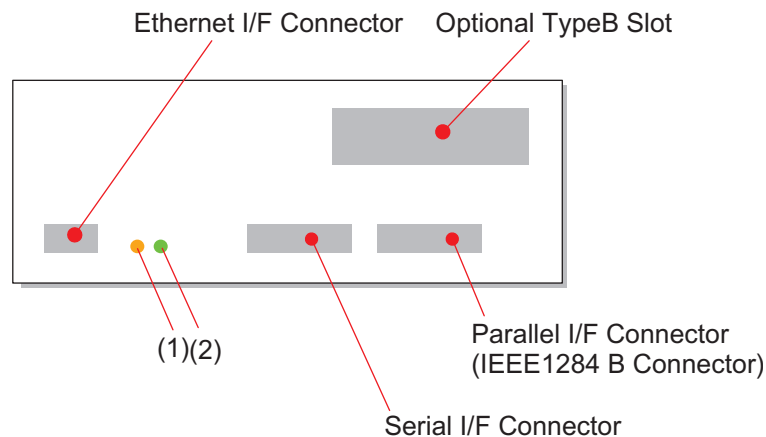

(1) 100Base/10Base Lamp (Color: Orange)

(2) Link/Reception Lamp (Color: Green)

Figure 1-4. Interface Slot Location

1.3.1 Host Interface Usage Configurations

The EPL-N2700 has the automatic interface switching mode. however, the interface to be used can be fixed by a control panel operation.

Table 1-19. Host Interface Usage Configurations

	Parallel I/F	Serial I/F	Ethernet I/F	Type B I/F
1. Automatic I/F switching	Usable	Usable	Usable	Usable
2. Fixed I/F (Parallel)	Usable	Not Usable	Not Usable	Not Usable
3. Fixed I/F (Serial)	Not Usable	Usable	Not Usable	Not Usable
4. Fixed I/F (Ethernet)	Not Usable	Not Usable	Usable	Usable
5. Fixed I/F (Type B I/F)	Not Usable	Not Usable	Not Usable	Usable

1.3.2 Parallel Interface

- Interface type: IEEE1284 bidirectional high-speed parallel interface
- Operation modes: Compatibility, Nibble, ECP
- Connector: 57RE-40360-830B(D7A) DDK or equivalent
- Applicable plug: Amphenole equivalent
- Device ID:

```
*1;
MFG: EPSON;
CMD: P JL, E JL, ESCPL2-00, ESCP9-84, PRPXL24-01, HP ENHANCED
      PCL5, HPGL2-01, ESCPAGE-04, ESCPAGE-04** *2;
MDL: *3
CLS: PRINTER;
DES: EPSON EPL-N2700;
```

*1. Total length of Device ID + 2 (hex) are entered in hexadecimal.

*2. The following character string appears when an optional ROM DIMM is installed:

- PostScript 3 DIMM: ,POSTSCRIPT (TBD)

*3. Displays model name: EPL-N2700

NOTES:

- Page returns have been inserted in the explanation above to make it easier to read, but it is actually given in a serial string format without any breaks.
- The CMD parameters are shown in random order. The items MODE and STATUS are not included.
- DES has the values for the MFG and MDL which are connected with a space in between.

1.3.3 Serial Interface

- Type: RS-232C
- Synchronization: Asynchronous
- Transmission rates: 300 to 115200 bps
- Parity bit: Even, Odd or NONE
- Start bit: 1
- Stop bit: 1 / 2
- Data length: 7 or 8 bits
- Hardware protocols: DTR/DSR
- Software protocol: XON/XOFF (Robust mode is supported)
- Connector: 17LE-13250-27(D57) DDK or equivalent

1.3.4 Ethernet I/F

- I/F type: 10BaseT, 100BaseT, Half Duplex, Full Duplex (Switched at power on)
- Communication protocol:
 - IPX/SPX (IPX, SPX, NCP, RIP, SAP, PrintServer, RemotePrinter, NDS, SNMP)
 - NetBIOS (SMB)
NetBEUI
 - TCP/IP (IP, UDP, TCP, LPR, FTP, TELNET, APR, ICMP, RARP, BOOTP, DHCP, SNMP, HTTP)
 - AppleTalk (ELAP, DDP, ATP, PAP, AARP, NBP, ZIP, RTMP)
(When AppleTalk is used, items such as printer name must be set on the Web browser. EPSON Net and EPSON Net2 can not be used.)
- Connector: RJ45
- Applicable cable: 2-pair category 3, 4 or 5 UTP (10BaseT, 100BaseT)
(To conforms with ECC Class B, EN55022 Class B, VCCI Class B, a shielded cable must be used.) (TBD)
- Pin assignment: See Table 1-20.

Table 1-20. Ethernet I/F Pin Assignment

1	Tx+	0
2	Tx-	0
3	Rx+	1
4	N.C.	-
5	N.C.	-
6	Rx-	1
7	N.C.	-
8	N.C.	-

1.3.5 Type-B I/F

This printer is equipped with one slot for an optional Type-B interface card.

- Main System Type: MTP600dpi,PW7016dt600dpi,PRG(****)rev, AP1300ma,SPD0fast (****: ROM version)
- Printer Name: Factory value is the same as the Product Name.
- Product Name: EPL-N2700
- Emulation type: See Table 1-21.
- Entity type: See Table 1-21.

When the emulation is set to "Auto", the following Entity Types are returned:

- If PS is supported:
EPSONPCL5, EPSONPAGE4, EPSONLQ2
(EPSONHPGL2, EPSONFX, EPSONPRPXL24)*
- If PS is unsupported:
LaserWriter, EPSONPCL5, EPSONPAGE4
(EPSONNLQ2, EPSONHPGL2, EPSONFX, EPSONPRPXL24)*

* The Entity Types in the brackets are returned when the number of multi-entity is 3 or more.

Table 1-21. Emulations Available

Emulation	Emulation Type	Entity Type
LJ4	PCL5E-00	EPSONPCL5
GL/2	HPGL2-01	EPSONHPGL2
PS	POSTSCRIPT-00	LaserWriter
FX	ESCP9-84	EPSONFX
ESCP2	ESCPL2-00	EPSONLQ2
1239X	PRPXL24-01	EPSONPRPXL24
ESC/Page	ESCPAGE-04	EPSONPAGE4
ESCP2	ESCP24C-84	EPSONLQ0C
RCC *1	-	-

*1: Can not be selected by users.

1.4 Panel Operation

The control panel of the EPL-N2700 includes a variety of buttons and indicator lamps, together with an LCD. The user can use the panel to select the printer's operating mode, to set the various printer functions, and to view settings and status information.

1.4.1 Control Panel.

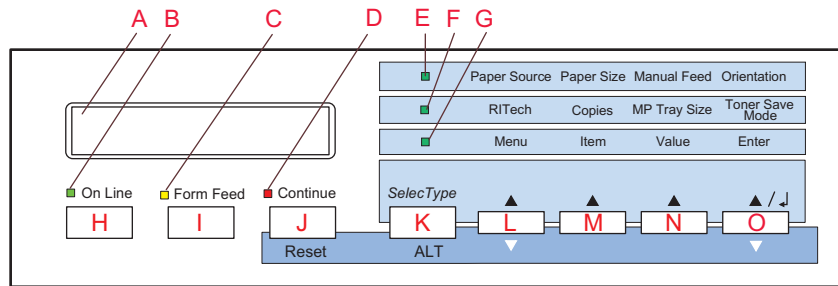

Figure 1-5. EPL-N2700 - Control Panel

LCD PANEL

1-line by 20 column LCD display equipped with backlog, and it is used for displaying printer status and setup menus

LED INDICATORS

- On Line LED (Green)
 - ON: Printer is ready to receive data and print.
 - OFF: Printer is not for receiving print data.

- Data LED (Yellow)
 - ON: Printer contains data that has not yet been processed. (If data is not effective print data, light will not be on.)
 - OFF: Printer has finished processing all print data. (If control code is not terminated, however, this lamp will be ON.)
 - Blinking: Printer is currently processing data.
- Continue LED (Red)
 - Blinking: Printer is in an error state. User can clear the error by pressing the Continue button.
- One-Touch Mode 1 LED (Green)
 - Indicate that the printer is in One-Touch mode 1. This mode offers the direct access to the following items:
 - Paper Source, Paper Size, Manual Feed, Orientation
- One-Touch Mode 2 LED (Green)
 - Indicate that panel is in One-Touch mode 2. This mode offers the direct access to the following items:
 - RITech, Copies, MP Tray Size, Out Bin
- SelecType (Green)
 - Indicates that printer is in SelecType setting mode.

NOTE: All LEDs come on when a service-call error has occurred.

BUTTONS

- On Line button
 - Toggles printer ON-LINE state on and off. (If printer is in one of the setup modes, this switch releases the mode and sets the printer to On-Line state.)

- Form Feed button
If the printer contains data but is not enabled for printing (if Form Feed lamp is on), this switch causes printer to output printing results and eject the paper. (This button does not cause ejection if Form Feed lamp is off.)
- Continue button
Clears error (if pressed while Continue LED is blinking). When printer is in On-Line state, this button will also clear any warning display that may appear on the LCD.
- SelecType / ALT button
Selects the panel setting mode: OneTouch Mode 1, OneTouch Mode 2, or SelecType Mode. Also operates as a ALT key. Panel button operations vary according to the currently selected panel setting mode.
- MENU button
Selects the corresponding OneTouch mode setting listed above this button, or selects the SelecType menu if in SelecType mode. Press this button when the printer is on-line to enter SelecType mode.
- ITEM button
Selects the corresponding OneTouch mode option listed above this button, or selects the function available within the current menu, after entering the SelecType mode.
- VALUE button
Selects the corresponding OneTouch mode option listed above this button, or selects the parameter available within the current item, after entering the Item of the SelecType mode.
- ENTER button / Status Sheet print
Selects the corresponding OneTouch mode option listed above this button, or accepts the setting currently shown on the LCD as a new

setting when in SelecType mode.

Press this button twice when the printer is on-line to print the Status Sheet.

- RESET (ALT + Continue)
Pressing the Continue button while holding down the ALT button will reset the printer. The LCD will display the message RESET. To generate a complete reset (warm boot), continue to hold down these buttons for approximately five seconds after the RESET message appears; the message will then change to RESET ALL and the printer will start warm-up processing.



1. **This printer has a non-volatile memory (EEPROM) to store various setting values and print data. If the printer power is turned off while it is writing data, the ongoing writing operation is not completed and an error may occur at the next power on. Therefore, be sure not to turn the printer off when the printer is in any of the following conditions because a writing operation is processing.**
 - Printer is turned on but the On Line LED has not come on yet.
 - On Line LED is blinking.
 - Printer is printing. (PF motor is live.)

2. **To stop printing, press the On Line button or perform Job Cancel / Reset operation.**

1.4.2 Panel Settings

1.4.2.1 Setting Items

The following tables show the panel setting options available.

Table 1-22. SelecType Option (1/7)

MENU Button	
ITEM Button	VALUE Button
Test Menu	
Status Sheet Network Status Sheet PS3 Status sheet *1 PS3 Font Sample *1 ESC/Page Font Sample *4 LJ4 Font Sample FX Font Sample 1239S Font Sample	
Emulation Menu	
Parallel / Serial / Network / AUX *2	Auto / LJ4 / ESCP2 / FX / I239X / PS3 *1 / GL2
Printing Menu	
Paper Source Page Size Wide A4 Orientation Out Bin Copies Quantity *26 Manual Feed Resolution Skip Blank Page *9 Duplex *10 Binding *10 (Continued to the next table)	Auto / MP / LC1 / LC2 *3 / LC3 *3 A4 *20 / A3 / A5 / B4 / B5 / LT *19 / B / HLT / LGL / GLT / GLG / EXE / F4 / MON / C10 / DL / C5 / C6 / IB5 / CTM OFF / ON Port / Land Face-Down / Stacker *6 / Staple *8 / Mailbox 1 *7 - 10 *7 / Sorter *25 1 - 999 1 - 999 OFF / ON 600 / 300 OFF / ON OFF / ON Long Edge / Short Edge

Table 1-23. SelecType Option (2/7)

MENU Button	
ITEM Button	VALUE Button
Printing Menu	
(Continued from the previous table)	
Start Page *10 Offset Stacking *11 Finish *12 Staple Position *12 Punch *12	Front / Back OFF / ON None / Staple Left / Right None / Punch
Tray Menu	
MP Mode MP Tray Size LC1 Size *13 LC2 Size - LC3 Size *3 *13 MP Type LC1 Type LC2 Type *3, LC3 Type *3	Normal / Last Auto *5 / A4 / A3 / A5 / B4 / B5 / B / LT / HLT / LGL / GLT / GLG / EXE / F4 / MON / C10 / DL / C5 / C6 / IB5 A4 / A3 / B4 / LT / B / LGL / GLT A4 / A3 / B4 / LT / B / LGL / GLT (Universal Cassette), A4, LT, B5 (LCC) Plain / Preprinted / Letterhead / Bond / Recycle / Color / Transprncy / Labels Plain / Preprinted / Recycle / Color Plain / Preprinted / Recycle / Color
Config Menu	
RTech Toner Save Density Top Offset Left Offset T Offset B. *10 L Offset B. *10 Size Ignore Auto Cont Page Protect Image Optimum Paper Type	ON / OFF OFF / ON 3 / 4 / 5 / 1 / 2 -150.0 - 0.0 - 150.0 (step: 0.5mm) -150.0 - 0.0 - 150.0 (step: 0.5mm) -150.0 - 0.0 - 150.0 (step: 0.5mm) -150.0 - 0.0 - 150.0 (step: 0.5mm) OFF / ON OFF / ON Auto / ON Auto / OFF / ON Normal / Thick W / Thick N / Trnsprnc / Ltrhead

Table 1-24. SelecType Option (3/7)

MENU Button	
ITEM Button	VALUE Button
Setup Menu	
Interface	<u>Auto</u> / Parallel / Serial / Network / AUX *2
Time Out	0, 5 - <u>60</u> - 300 (step: 1)
Standby *14	<u>Enable</u> / Disable
Lang	<u>English</u> / Français / Deutsch / ITALIANO / ESPANOL / SVENSKA / Dansk / Nerderl. /SUOMI / Português
Panel Lock *15	<u>OFF</u> / ON
Toner *13	E****F – E □□□□ F
Multibin *27	<u>Mailbox</u> / Stacker / Sorter / MultiSort
Finisher *12	Mailbox / Stacker / Sorter / MultiSort
Page Count *13	0 - 99999999
SelecType Init	
Parallel Menu	
Speed	<u>Fast</u> / Normal
Bi-D	<u>Nibble</u> / ECP / OFF
Buffer Size	<u>Normal</u> / Maximum / Minimum
Serial Menu	
Word Length	<u>8</u> / 7
Baud Rate	<u>9600</u> / 19200 / 38400 / 57600 / 76800 / 115200 / 300 / 600 / 1200 / 2400 / 4800
Parity	<u>None</u> / Even / Odd
Stop Bit	<u>1</u> / 2
DTR	<u>ON</u> / OFF
Xon/Xoff	<u>ON</u> / OFF / Robust
Buffer Size	Normal / Maximum / <u>Minimum</u>
Network Menu	
Get IPAddress	Panel / DHCP / PING
IP Byte 1 - IP Byte 4	<u>0</u> – 255
SM Byte 1 - SM Byte 4	<u>0</u> – 255
GW Byte 1 - GW Byte 4	<u>0</u> – 255
Buffer Size	<u>Normal</u> / Maximum / Minimum
AUX Menu *2	
Buffer Size	<u>Normal</u> / Maximum / Minimum

Table 1-25. SelecType Option (4/7)

MENU Button	
ITEM Button	VALUE Button
ESC/Page Menu *4	
Auto CR	<u>On</u> / Off
AutoFF	<u>On</u> / Off
CR Function	<u>CR</u> / CR+FF
LF Function	<u>CR+FF</u> / LF
FF Function	<u>CR+FF</u> / FF
Error Code	<u>Ignore</u> / Space
Avoid Error	<u>Off</u> / On
PGI	<u>On</u> / Off
LJ4 Menu	
FontSorce	<u>Resident</u> / Download / ROM A *23 / ROM B *23
Font Number	<u>0</u> - available (max. 65535)
Pitch *22	0.44 - <u>10.00</u> - 99.99 (step:0.1cpi)
Height *22	4.00 - <u>12.00</u> - 999.75 (step:0.25pt)
SymSet	<u>IBM-US</u> / Roman-8 / ECM94-1 / 8859-2 ISO / 8859-9 ISO / IBM-DM / PcMultiling / PcE.Europe / PcTk437 / WiAnsi / WiE.Europe / WiTurkish / DeskTop / PsText / VeInternati / VeUS / MsPublishin / Math-8 /PsMath / VeMath / PiFont / Legal /UK / ANSI ASCII / Swedish2 / Italian / Spanish / German / Norweg1 / French2 / Windows / Pclcelandic*18/ Pclt774*18/ PcTurk1*18/ PcPortugues*18/ PcEt850*18/ PcTurk2*18 / PcCanFrench*18/ PcSI437*18/ PcNordic*18 / 8859-3 ISO*18 / 8859-4 ISO*18 / WiBaltic*18 / WiEstonian*18 / WiLatvian*18 / Mazowia*18 / CodeMJK*18 / BpBRASCII*18 / BpAbicomp*18 / PcGK437*18 / PcGk851*18 / PcGk869*18 / 8859-7 ISO*18 / WiGreek*18 / Europe3*18 / PcCy855*18 / PcCy866*18 / Pclt866*18 / 8859-5 ISO*18 / WiCyrillic*18 / Bulgarian*18 / PcUkr866*18 / Hebrew7*18 / 8859-8 ISO*18 / Hebrew8*18 / PcHe862*18 / Arabic8*18 / PcAr864*18 / 8859-6 ISO*18 / OCR A*18 / OCR B*18
Form	<u>5</u> - <u>60</u> *19 - <u>64</u> *20 - 128
Source Symset *18	0 - <u>277</u> - 3199
Dest Symset *18	0 - <u>277</u> - 3199
CR Function	<u>CR</u> / CR+LF
LF Function	<u>LF</u> / CR+LF

Table 1-26. SelecType Option (5/7)

MENU Button	
ITEM Button	VALUE Button
GL2 Menu	
GL-Mode	GLlike / <u>LJ4GL</u>
Scale	<u>OFF</u> / A0 / A1 / A2 / A3
Origin	<u>Corner</u> / Center
Pen	<u>Pen0</u> / 1 / 2 * ¹⁶ - 6 * ¹⁶
End	<u>Butt</u> / Square / Triangular / Round
Join	<u>Mitered</u> / Mitereddeveled / Triangular / Round / Beveled / None
Pen0/1	0.05 - 0.35 - 5.00 (step:0.05mm)
Pen2 * ¹⁶ - 6 * ¹⁶	0.05 - 0.35 - 5.00 (step:0.05mm)
PS3 Menu *1	
Error Sheet	<u>OFF</u> / ON
ESCP2 Menu	
Font	<u>Courier</u> / Prestige / Roman / Sans serif / Roman T / Orator S / Sans H / Script / OCR A / OCR B
Pitch	<u>10cpi</u> / 12cpi / 15cpi / Prop.
Condensed	<u>OFF</u> / ON
T.Margin	0.40 - <u>0.5</u> - 1.50 (step:0.05")
Text	1 - <u>62</u> * ¹⁹ - <u>66</u> * ²⁰ - available (max 111)
CGTable	<u>PcUSA</u> / Italic / PcMultilin / PcPortugue / PcCanFrenc / PcNordic / PcTurkish2 / PcE.Europe / BpBRASCII / BpAbicom 8859-15ISO / PcEur858 / PcS1437* ¹⁸ / PcTurkish1* ¹⁸ / Pclcelandic* ¹⁸ / 8859-9 ISO* ¹⁸ / Mazowia* ¹⁸ / CodeMJK* ¹⁸ / PcGk437* ¹⁸ / PcGK851* ¹⁸ / PcGk869* ¹⁸ / 8859-7 ISO* ¹⁸ / PcCy855* ¹⁸ / PcCy866* ¹⁸ / Bulgarian* ¹⁸ / PcUkr866* ¹⁸ / Hebrew7* ¹⁸ / Hebrew8* ¹⁸ / PcAr864* ¹⁸ / PcHe862* ¹⁸
Country	<u>USA</u> / French / Germany / UK / Denmark / Sweden / Italy / Spain1 / Japan / Norway / Denmark2 / Spain2 / LatinAmeric / Korea / Legal
Auto CR	<u>ON</u> / OFF
Auto LF	<u>OFF</u> / ON
Bit Image	<u>Dark</u> / Light / BarCode
ZeroChar	<u>0</u> / 0 (slashed)

Table 1-27. SelecType Option (6/7)

MENU Button	
ITEM Button	VALUE Button
FX Menu	
Font	<u>Courier</u> / Prestige / Roman / Sans serif / Roman T / Orator S / Sans H / Script / OCR A / OCR B
Pitch	<u>10cpi</u> / 12cpi / 15cpi / Prop.
Condensed	<u>OFF</u> / ON
T.Margin	0.40 - <u>0.5</u> - 1.50 (step:0.05")
Text	1 - <u>62</u> * ¹⁹ - <u>66</u> * ²⁰ - available (max 111)
CGTable	<u>PcUSA</u> / Italic / PcMultilin / PcPortugue / PcCanFrenc / PcNordic / PcTurkish2 / PcE.Europe / BpBRASCII / BpAbicom 8859-15ISO / PcEur858
Country	<u>USA</u> / French / Germany / UK / Denmark / Sweden / Italy / Spain1 / Japan / Norway / Denmark2 / Spain2 / LatinAmeric
Auto CR	<u>ON</u> / OFF
Auto LF	<u>OFF</u> / ON
Bit Image	<u>Dark</u> / Light / BarCode
ZeroChar	<u>0</u> / 0 (slashed)
I239X Menu	
Font	<u>Courier</u> / Prestige / Gothic / Orator / Script / Presentor / Sans serif
Pitch	<u>10cpi</u> / 12cpi / 15cpi / 17cpi / 20cpi / 24cpi / Prop.
Code Page	<u>437</u> / 850 / 860 / 863 / 865
T.Margin	0.30 - <u>0.40</u> - 1.50 (step:0.05")
Text	1 - <u>63</u> * ¹⁹ - <u>67</u> * ²⁰ - available (max 111)
Auto CR	<u>OFF</u> / ON
Auto LF	<u>OFF</u> / ON
Alt. Graphic	<u>OFF</u> / ON
Bit Image	<u>Dark</u> / Light
ZeroChar	<u>0</u> , 0 (slashed)
CharacterSet	1 * ¹⁹ / <u>2</u> * ²⁰

Table 1-28. SelecType Option (7/7)

MENU Button	
ITEM Button	VALUE Button
Maintenance Menu ^{*24}	
Engine Status Sheet	
Fuser Counter Clear	
MP Counter Clear	
LC1 Counter Clear	
LC2 Counter Clear ^{*21}	
LC3 Counter Clear ^{*21}	
TR Counter Clear	
Errlr Long Clear	

NOTES:

- 1: Appears only when an optional PostScript Level 3 DIMM is installed.
- 2: Appears only when an optional TypeB Interface Card is installed.
- 3: Appears and can be selected only when an optional lower cassette unit is installed.
- 4: Does not appear on the panel nor status sheet.
- 5: When "Auto" is selected, the following paper sizes can be detected.
 - North American version: LT, HLT, LGL, EXE, GLG, GLT, B
 - Other versions: A3, A4, A5, IB5, LTR, LGL, F4
- 6: Appears and can be selected only when 5-Bin Unit or 10-Bin Unit is installed and the Stacker mode is enabled.
- 7: Appears and can be selected only when 5-Bin Unit (Mail box 1 - 4) or 10-Bin Unit (Mail box 1-9) is installed in the Mailbox mode.
- 8: Does not appear.
- 9: Effective only in the ESC/Page or PCL mode.
- 10: Appears only when an optional Duplex Unit is installed.
- 11: Appears only when an optional 5-Bin Unit or Finisher is installed.
- 12: Does not appear.
- 13: Appears but not to be selected.
- 14: STANDBY command of the EJL is also supported. The default is 60 minutes. (Not intended for users.)
- 15: Does not appear on the panel nor status sheet. Only set in EJL.
- 16: Appears only in the GLike mode.
- 17: The selected value is not effective until the next warm boot or power on.
- 18: Appears only when the NLSP Bitmap 3 Plus ROM DIMM is installed.
- 19: Default for the North American version.

- 20: Default for the versions other than the North American version.
- 21: Appears even though the optional unit is not installed. The counter is also cleared.
- 22: Either "Height" or "Pitch2" appears, depending on the selected font type;
 - Constant pitch font: "Pitch"
 - Proportional pitch font: "Height"
- 23: Appears only when an optional Font DIMM is installed in the optional ROM DIMM Socket.
- 24: Appears when the maintenance menu is activated by the power-on service function.
- 25: Appears and can be selected only when an optional 5-Bin Unit or 10-Bin Unit is installed in the Sorter or MultiSort mode.
- 26: Does not appear on the panel nor status sheet but can be set in the EJL or PJL.
- 27: Appears and can be selected only when an optional 5-Bin Unit or 10-Bin Unit is installed. After exiting the panel setting mode in which the selection has changed, warm-boot is executed. Also, after the selection has changed, "Test Menu" is not shown until the panel setting mode is terminated.

1.4.2.2 User Setting Items which are not include in the Setting Menu

The items shown below are not included in the setting menu but can be set by users. The values set by the users are not cleared by the initialization through the control panel.

Setting Item	Setting value	Default Value	Setting method
PrinterName	32-byte character string	EPL-N2700	EJL, Printer Name Command
Device ID MFG	32-byte character string	(Undefined)	EJL
Device ID MDL	32-byte character string	(Undefined)	EJL
Device ID DES	32-byte character string	(Undefined)	EJL
Device ID CID	32-byte character string	(Undefined)	EJL
Mail Bin 1 - 10 NAME	24-byte data	(Undefined)	EJL
MP Tray compensation	-0.4 mm to 4.00 mm (in 0.5 mm steps)	0.0 mm	EJL
LC1 - LC3 compensation	-0.4 mm to 4.00 mm (in 0.5 mm steps)	0.0 mm	EJL
Duplex compensation	-0.4 mm to 4.00 mm (in 0.5 mm steps)	0.0 mm	EJL

1.4.2.3 Setting Item Description

This section provides the information on the product-specific setting item.

MP Tray Size

“Auto” is added and the North American version automatically detects LT, HLT, LGL, EXE, GLG, GLT, and B paper sizes, while the versions for areas other than North America detect the A3, A4, A5, IB5, LTR, LGL, and F4 paper sizes. When “Auto” is selected, the following conditions should be considered:

- If the edge guide is set to any position other than automatic selectable paper sizes, the paper size loaded is detected A3.
- The automatically selected paper size is shown in Status Sheet and EJL status.

MP Type

Selects the paper type for the MP Tray.

If “Paper Source” is set to “Auto”, the printer automatically selects the paper source that matches the selected paper type from the paper sources that currently store the selected paper size.

The MP Type selected during paper source selection is only specified with the EJL command.

In printer modes that have no specification command, operations are the same as when “Plain” is set for “MP Type”.

The EPL-N2700 has the setting item “Paper Type”, if the “Paper Type” is set to “Normal” and “MP Tray” is set to “Transprnc” or Letterhead”, the MP Type is also set to the engine side.

LC1 to LC3 Type

These are basically same as the MP Type but because special paper cannot be fed from the LC1 - LC3, "Letterhead", "Bond", "Transprnc", and "Labels" can not be selected.

Paper Source

The priority for selecting the paper source is in the order of MP Tray > LC1 > LC2 > LC3. (Applicable when "MP Tray Mode" is set to "Normal".) The combination of the optional paper sources and the name during the selection is as shown in the below:

Table 1-29. Combination of the Optional Paper Cassette and Corresponding Names

MP Tray	LC1	LC2	LC3	Remarks
Standard	Standard	---	---	No option installed
Standard	Standard	500-sheet cassette unit	---	One 500-sheet cassette unit installed
Standard	Standard	500-sheet cassette unit	500-sheet cassette unit	Two 500-sheet cassette units installed
Standard	Standard	LCC *	---	LCC installed
Standard	Standard	500-sheet cassette unit	LCC *	One 500-sheet cassette unit and LCC installed

*: Large Capacity Lower Cassette

Multibin

The values that can be selected for the "Out Bin" in the "Printing Menu" vary depending on the selection made for the "Multibin" in "Setup Menu" as shown in the following table:

Table 1-30. "Multibin" Settings and Corresponding Outbins Available

	Mailbox	Sorter	Multisort	Stacker
Without option	Face-down	Face-down	Face-down	Face-down
5-bin unit	Face-down, Mailbox 1, Mailbox 2 - 5	Face-down, Sorter	Face-down, Sorter	Face-down, Stacker
10-bin unit	Face-down, Mailbox 1, Mailbox 2 - 10	Face-down, Sorter	Face-down, Sorter	Face-down, Stacker

NOTES:

1. When an optional unit is installed, the standard Face-down can no be used. So, "Face-down" in this case means another device.
2. If any item which can not be selected due to operation mode of the Outbin is selected by the EJL or ESC/Page command, the selection is ignored,
3. If Face-down is selected in the 5-bin or 10-bin mailbox mode, paper is output to Mailbox 1.

Output Tray Selection Specifications

<5-bin unit>

- When "Multibin = Stacker" and "Outbin = Stacker" are selected:
 - The sequence of outbin destinations is Bin2 > Bin3 > ---> Bin 5 > Bin1.
 - The printer searches some consecutive empty bins in the order of Bin 5 - Bin 2, and paper will be output to the empty bin which found last in the search.

<10-bin unit>

- When "Multibin = Stacker" and "Outbin = Stacker" are selected:
 - The sequence of outbin destinations is Bin10 > Bin9 > ---> Bin 2 > Bin1

- The printer searches some consecutive empty bins in the order of Bin 2, Bin 3 - - -, and paper will be output to the empty bin which found last in the search.
- When “Multibin = Sorter” and “Outbin = Sorter” are selected:
 - The sequence of ejected paper destination is Bin10 > Bin 9 > - - Bin1.
- When “Multibin = MultiSort” and “Outbin = Sorter” are selected:
 - If requested copies is 9 or less, ejection starts at Bin 2. If requested copies is 10 or more, ejection starts at Bin 1, and when all pages are ejected, next ejection starts at Bin3 and then in the following order; 4, 5, - - - 10, and 1.

<Items of restriction on the paper tray>

When the 5-bin or 10-bin is installed:

When the “Out Bin” is set to other than Face-down, “Outbin Select Error” will occur if the printer is in any of the following conditions:

- Paper size is any of the A5, B5, GLT, HLT, EXE, MON, C10, DL, C5, or custom.
- Paper type is other than “Plain”.
- “Paper Type” is set to “Transprnc” or “Label”.

NOTE: To check the condition, see the paper source that was selected by the user and also the one from which the paper was fed.

Quantity (Printing Menu)

The number of copies is specified by the job unit. It has a priority over the number set for “Copies”. Accordingly, if “Quantity” is set to “2” or larger, the value set for “Copies” is not effective. This is set with EJL or

ESC/PAGE command. The setting value is not stored in memory. If on-job data is too large to store, the printer shows the warning “Collate was disabled” and prints one set only.

Duplex (Printing Menu)

Selects Single of Duplex printing.

<Items of restriction on the duplex printing>

When the printer is in any of the conditions below, “Can’t Print Duplex” is indicated and printing is disabled.

- Paper size is any of the MON, C10, DL, C5, or custom.
- Paper type is other than “Plain”.
- “Paper Type” is set to “Transprnc” or “Label”.

NOTE: To check the condition, see the paper source that was selected by the user and also the one from which the paper was fed.

Offset Stacking (Printing Menu) (TBD)

Turns on or off a use of the shifter when the installed Out Bin has a shifter. Since this selection affects all output devices, it is effective to the Face-down stacker for 5-bin unit. However, if any of the following settings is selected, this function is not effective despite paper is ejected to Bin1 for 5-bin unit:

- “Multibin = Stacker” and “Out Bin = Stacker” (for 5-bin unit)
- “Multibin = Mailbox”
- “Out Bin = Mailbox1”

1.4.3 One-Touch Setting

The One-Touch setting function of the printer offers the quick access to the following panel setting items, which are frequently changed:

Table 1-31. One-Touch Setting Functions

Button	Menu	Item	Value	Enter
One-Touch Setting 1	Paper Source	Page Size	Manual Feed	Orientation
One-Touch Setting 2	RITech	Copies	MP Tray Size	Toner Save Mode

1.4.4 Special Functions

Built-in special function can be selected by turning on the printer while holding down the specific combination of button(s). Table 1-32 lists the special functions supported by the printer.



All special functions but the hex dumps are intended for service technicians only and are not open to users.

Table 1-32. Special Functions Available

Functions	Button to Press while Tuning on the Printer
Hex-Dump	Form Feed
EEPROM Initialization	On Line, Continue, Menu
Panel Setting Initialization	Continue
Formatting Flash ROM	Alt, Item, Value, Enter
Updating the Program ROM	On Line, Alt, Value
Copying the ROM module	On Line, Alt, Enter
Maintenance mode	One Line, Form Feed, Continue,
CPU when a Service-call error is generated	Alt, Menu, Item, Value, and Enter
Printing an error sheet	Press Enter twice after resetting the CPU when a service-call error occurs.

Hex-Dump Mode

Converts received data into hexadecimal ASCII codes. Effective all interfaces.

- Button to press: "Form Feed" while turning on the printer
- Exit: Switch the printer off or perform Warm-boot by job cancel or reset.

EEPROM Initialization

Initializes all controller-side values stored in the EEPROM to factory default values.

- Button to press: "On Line", "Continue", and "Menu" while turning on the printer



The Total Counter, Tray Counter, and transfer Roller Counter, which are managed by the mechanical controller side, are not initialized.

Panel Setting Initialization

Initializes all panel settings to the factory default values. The printer performs a warm-boot operation and returns to the normal status after the initialization.

- Button to press: "Continue" while turning on the printer
- Exit: Switch the printer off or perform Warm-boot by job cancel or reset.



- This function initializes all user-selectable settings.
- The values such as total printed pages, toner remaining level, paper remaining level, and all items printed on an Engine Status Sheet, which are affected by the printer operation and maintenance operation, are not cleared.

Formatting the Flash ROM Module

This function erases all contents of the flash ROM module attached to the DIMM ROM module A slot on the main board.

- Button to press: "Alt", "Item", "Value", "Enter" while turning on the printer
The printer starts initializing when the message "DIMM A ERASING" appears. When the job is completed, the printer performs a warm-boot operation to return to the normal status.

Updating the Program ROM

This function updates the program DIMM in the program socket on the main board.

- Button to press: "On Line", "Alt", and "Value" while turning on the printer

Copying the ROM Module

This function copies the contents of the ROM module in the socket B on the main board to the flash ROM module in the socket A. If no ROM module is in the socket B, the contents of the ROM module in the Code ROM socket is copied.

- Button to press: Press “On Line“, “ALT“, and “Enter“ while turning on the printer. Then, when the LCD indicates “DIMM COPY MODE“, press the “Enter“ button, and the printer erases the contents of the Flash ROM and then starts copying. To return to the normal status, the printer performs a warm-boot operation.

1.4.5 Maintenance Mode



When executing any function but “Error Log Clear“, make sure the engine is not live completely.

By entering the Maintenance mode, “Maintenance Mode“ is added to the setting menu options, and the mode is enabled after the worm-boot operation is executed. To return to the normal mode, perform the warm-boot operation.

- Engine status sheet
Prints an engine status sheet.

NOTE: *Before running an engine status sheet, make sure that the printer is free from any engine related error in the normal mode.*

- Fuser Counter Clear
 - A servicer performs this operation once whenever he/she has replaced the fuser.
 - This function returns the value for the Fuser Counter to zero and the counter value for the Fuser Change increases by one which are shown on the engine status sheet.
- MP Counter Clear
 - A servicer performs this operation once whenever he/she has replaced the feed roller in the MP tray.
 - This function returns the value for the MP Counter to zero and the counter value for the MP FR Change increases by one which are shown on the engine status sheet.

- LC1 - LC3 Counter Clear
 - A servicer performs this operation once whenever the feed roller in the LC1/LC2/LC3 has been replaced.
 - This function returns the value for the LC1/LC2/LC3 Counter to zero and the counter value for the LC1/LC2/LC3 FR Change increases by one which are shown on the engine status sheet.
- TR Counter Clear
 - A servicer performs this operation once whenever the transfer roller has been replaced.
 - This function returns the value for the TR Counter to zero and the counter value for the TR Change increases by one which are shown on the engine status sheet.
- Error Log Clear

Clears the error log list stored to print on the Engine Status Sheet. The error log list stores the most recent 20 errors.

1.4.5.1 Engine Status Sheet

A sample print of the Engine Status Sheet is shown below:

```

Engine Status Sheet
Total Counts          600,000 sheets
Jam Counts            100,000
ET Cartridge
  Toner               100%
  OPC Counter         600,000 min
  Cartridge Change    10
Fuser
  Fuser Counter       600,000 sheets
  Fuser Change        10
Input
  LC1 Counter         600,000 sheets
  LC2 Counter         600,000 sheets
  LC3 Counter         600,000 sheets
  MP Counter          600,000 sheets
  LC1 FR Change       10
  LC2 FR Change       10
  LC3 FR Change       10
  MP FR Change        10
Transfer Roller
  TR Counter          600,000 sheets
  TR Change           10
Adjust
  MP                  0.0 mm
  LC1                 0.0 mm
  LC2                 -0.4 mm
  LC3                 0.0 mm
  Duplex              0.0 mm
Engine Version
  MCU                 020101
  Multibin             001012
  Finisher            000000
Error Log
  Panel Message       Code      Page
  ZZZZZZZZZZZZZZZZZZ  xxxx      YYYYYYYY
  
```

Figure 1-6. Sample Engine Status Sheet

NOTE: The Engine Status Sheet does not show the version number of the options which are not installed.

NOTE: Removal of options does not clear their counter values.

- Total Counts
 - Shows the same value as the one for the “Page Count” in the “Setup Menu”.
- Jam counts:
 - Shows the number of times jams occurred.
- ET Cartridge:
 - Toner:
 - Shows the remaining toner level in one percent units.
 - OPC Drum:
 - Shows a total time of drum’s rotation in one minute units.
 - Cartridge Change:
 - Shows the number of times the ET cartridge has been replaced. With each detection of a new ET cartridge, the number increases with an increment of one.
- Fuser:
 - Fuser Counter:
 - Shows the total number of sheets printed after the latest Fuser Counter Clear operation in the Maintenance Menu. The count system is the same as for the Total Counter. Note there is a possibility that the counter shows a minus value when the Total Counter Clear is executed, since the counter actually shows the difference between the current value for the Total Counts and the one at the last fuser replacement.
 - Fuse Change:
 - Shows the number of times the fuser has been replaced. With each Fuser Counter Clear operation in the Maintenance Menu, the number increase with an increment of one.
- Input:
 - LC1/2/3 Counter:
 - Shows the total sheets number loaded from the LC1/2/3 after the last LC 1/2/3 Counter Clear in the Maintenance Menu. It is read on the engine side.
 - MP Counter:
 - Shows the total sheets number loaded from the MP tray after the last MP Counter Clear in the Maintenance Menu. Is is read on the engine side.
 - LC1/2/3 FR Change:
 - Shows the number of times the Feed Roll in the LC 1/2/3 has been changed. With each LC 1/2/3 Counter Clear operation in the Maintenance Menu, the number increases with an increment of one.
 - MP FR Change:
 - Shows the number of times the Feed Roll in the MP tray has been changed. With each MP Counter Clear operation in the Maintenance Menu, the number increases with an increment of one.
- Transfer Roller
 - TR Counter:
 - Shows the number of sheets that has passed through the transfer roller after the last TR Counter Clear in the Maintenance Menu. It is read on the Engine side.
 - TR Change:
 - Shows the number of times the Transfer Roller has been changed. With each TR Counter Clear operation in the Maintenance Menu, the number increases with an increment of one.

- Adjust
 - LC1
Shows the adjusting value for the LC1's main scanning direction. Set by EJL.
 - LC2
Shows the adjusting value for the LC2's main scanning direction. Set by EJL.
 - LC3
Shows the adjusting value for the LC3's main scanning direction. Set by EJL.
 - MP
Shows the adjusting value for the MP tray's main scanning direction. Set by EJL.
 - Duplex
Shows the adjusting value for the Duplex Unit's main scanning direction. Set by EJL. (Stage code, Modification management mode)
- MCU:
Shows the mechanical controller version for the printer main body. Read on the engine side.
- LCC:
Shows the mechanical controller version for the Large Capacity Lower Cassette. Read on the engine side.
- Multibin:
Shows the mechanical controller version for the Multibin unit. Read on the engine side.
- Error Log:
Shows the record of the most recent 20 errors that occurred. It includes corresponding LCD message, EJL status command, and total sheet number. They are shown in the order of recentness. The error types included are as follows:
 - Service-call error (Ones occurred after On Line indication.)
 - Paper Jam
 - LCC Error
 - Multibin ErrorIf an error has occurred for the total sheet number with which another error has been already recorded, the new error is not stored.

1.4.5.2 List of Data Controlled by the Engine Status Sheet and Controlling Method

Table 1-33. Data Controlled by the Engine Status Sheet and Controlling Method

Data name	Storage location	Storage location	Count condition	Clear condition
Total Counts	Mechanical controller	to 600,000 sheets	During printing	EJL (EEPROM initialization)
Jam Counts	Controller	to 100,000 sheets	When a jam occurs	(EEPROM Initialization)
Toner	Controller	0 - 100%	During printing	New one detected (EEPROM initialization)
OPC Counter	Mechanical controller		During printing	None
Cartridge Change	Controller	0 - 100 times	New one detected	(EEPROM initialization)
Fuser Counter	Controller	to 600,000 sheets	During printing	Panel, (EEPROM)
Fuser Change	Controller	0 - 10 times	Panel	(EEPROM initialization)
MP Counter	Controller	to 600,000 sheets	During a paper feed	Panel, (EEPROM initialization)
LC1 Counter	Controller	to 600,000 sheets	During a paper feed	Panel, (EEPROM initialization)
LC2 Counter	Controller	to 600,000 sheets	During a paper feed	Panel, (EEPROM initialization)
LC3 Counter	Controller	to 600,000 sheets	During a paper feed	Panel, (EEPROM initialization)
MP FR Change	Controller	0 - 10 times	Panel	(EEPROM initialization)
LC1 FR Change	Controller	0 - 10 times	panel	(EEPROM initialization)
LC2 FR Change	Controller	0 - 10 times	Panel	(EEPROM initialization)
LC3 FR Change	Controller	0 - 10 times	Panel	(EEPROM initialization)
TR Counter	Controller	to 600,000 sheets	During printing	
TR Change	Controller	0 - 10 times	Panel	
Error Code1	Controller		When an error occurs	Panel, (EEPROM initialization)
Error Page 1	Controller		When an error occurs	Panel, (EEPROM initialization)
:			When an error occurs	
Error Code 20	Controller		When an error occurs	Panel, (EEPROM initialization)
Error Page 20	Controller		When an error occurs	Panel, (EEPROM initialization)

NOTE:“Panel” in the “Clear condition” column means the value can be cleared by the Maintenance Mode.

NOTE:When the value controlled by the controller reaches the maximum, it does not increase any more.

1.5 Dimensions and Weight

DIMENSIONS

- Printer main body:
535 mm (W) x 559 mm (D) x 428 mm (H)
- Large Capacity Lower Cassette:
 - Unit itself: 535 mm (W) x 545 mm (D) x 284 mm (H)
 - With the main unit: 535 mm (W) x 559 mm (D) x 712 mm (H)
- 500-sheet Lower Cassette Unit:
535 mm (W) x 544 mm (D) x 127.5 mm (H)
(When stacked, each unit is 105 mm in height.)
- Duplex Unit:
 - Unit itself: 55 mm (W) x 415 mm (D) x 255 mm (H)
 - With the main unit: 615 mm (W) x 559 mm (D) x 428 mm (H)
- 10-bin Unit:
 - Unit itself: 480 mm (W) x 512 mm (D) x 863 mm (H)
 - With the main unit: 1097 mm (W) x 543 mm (D) x 890 mm (H)
- 5-bin Unit:
 - Unit itself: 481 mm (W) x 543 mm (D) x 356 mm (H)
 - With the main unit: 617 mm (W) x 543 mm (D) x 689 mm (H)

Top View

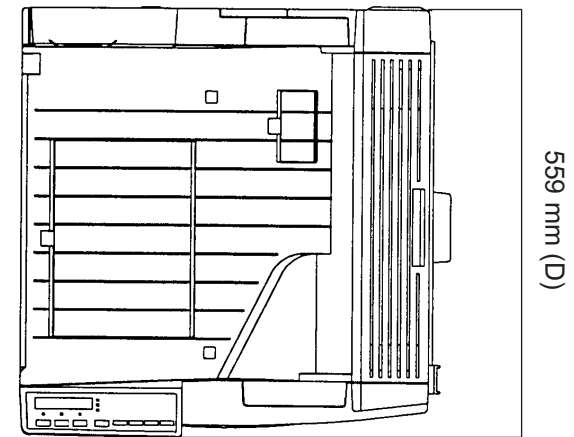

Front View

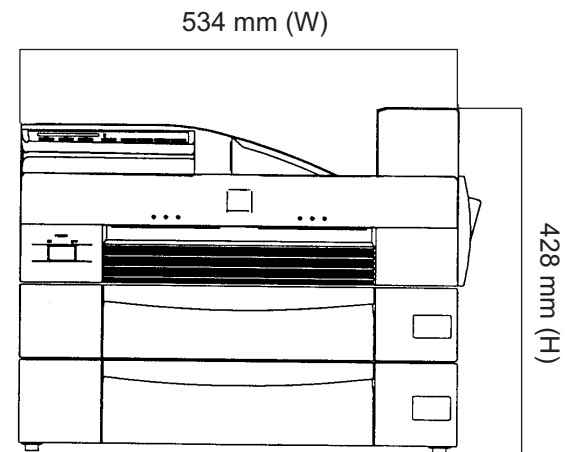

Table 1-34. Exterior View of the Printer Main Body

WEIGHT

- Printer main body:
30 Kg (Without any consumable or optional items)
- Large Capacity Lower Cassette:
17 Kg or less
- 500-sheet Lower Cassette Unit:
7 Kg or less (TBD)
- Duplex Unit:
2 Kg or less
- 10-bin Unit:
 - 10-bin portion:
25.9 Kg (including packed items)
 - Horizontal transport portion:
3.6 Kg (including packed items)
- 5-bin Unit:
12.2 Kg or less

CHAPTER

2

OPERATING PRINCIPLES

2.1 Printer Mechanism Operating Principles

The following diagram shows the major parts, including the sensors, and the paper paths in the printer. The printer consists of the paper feed section, print head unit (exposure section), imaging cartridge (charging section and development section), transfer section, fusing section, and paper exit section

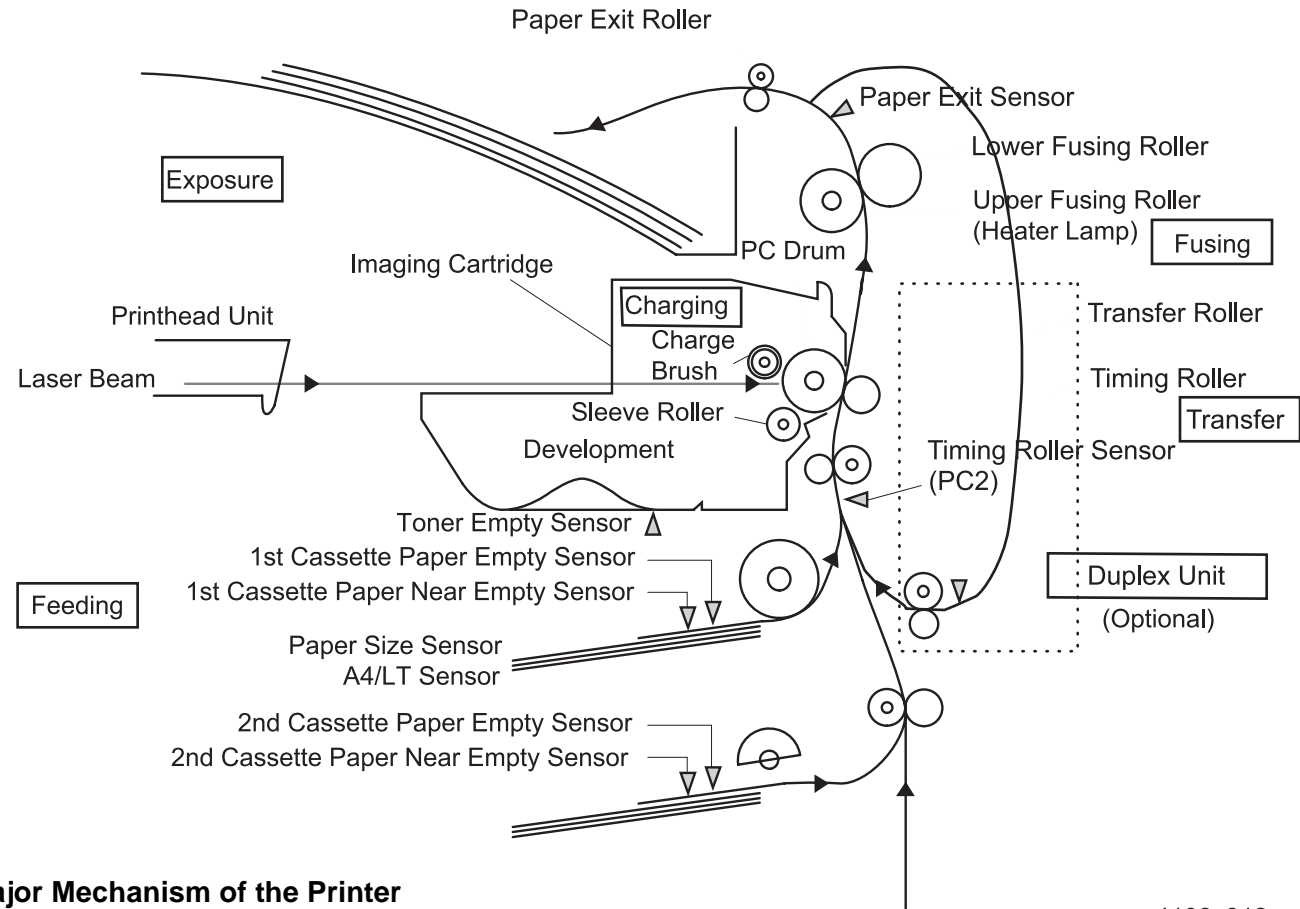

Figure 2-1. Major Mechanism of the Printer

4108s012

2.1.1 General Description of Each Section

□ Paper Feed Section

Paper is fed from either the MP Tray or Cassette 1 (universal cassette). When the printer receives a print command, the paper take-up solenoid turns ON and a sheet of paper is fed by the paper take-up roller.

The timing roller front sensor (PC2) detects the fed paper and the paper is fed to the timing roller for printing.

<Optional cassettes>

When optional cassette (500-sheet lower cassette/LCC) is installed, paper can be fed from respective paper sources.

NOTE: *The optional cassettes are the same as the Cassette 1 (universal cassette).*

□ Print Head Unit (Exposure Section)

The laser diode in the print head unit emits a laser beam corresponding to the print data. The laser beam falls on the rotating heptagonal polygon mirror to produce a scanning beam, producing an electrostatic latent image on the surface of the PC drum in the imaging cartridge.

□ Imaging Cartridge

The imaging cartridge consists of the charging section and development section. The moving parts of the imaging cartridge are driven by the I/C drive motor (M1). In the development section, toner is fed to the electrostatic latent image formed on the surface of the PC drum to produce a visible toner image on the PC drum.

□ Transfer Section

The transfer section transfers the toner image on the surface of the PC drum onto the paper.

□ Fusing Section

Using a heated roller, the fusing section permanently fixes the toner image onto the paper. The fusing temperature is controlled by using a heat sensitive element (thermistor) attached to the upper fusing roller.

□ Paper Exit Section

The paper which has passed the fusing section is ejected to the top of the printer with the paper exit roller. The paper exit sensor (PC3) senses the ejection of the paper.

When the optional duplex unit are installed:

For duplex printing, the trailing edge of the printed paper is drawn inside the duplex unit by the switch back motor in the duplex unit. Then, the paper is fed to the manual unit by the transport motor in the duplex unit and waits for the 2nd print command.

2.1.2 Gear/Roller Location

The gears and roller in the printer are located as shows in the figurer below. The transportation motor (M2) drives the transportation system and the I/D drive motor (M1) drives the gears in the Imaging Cartridge.

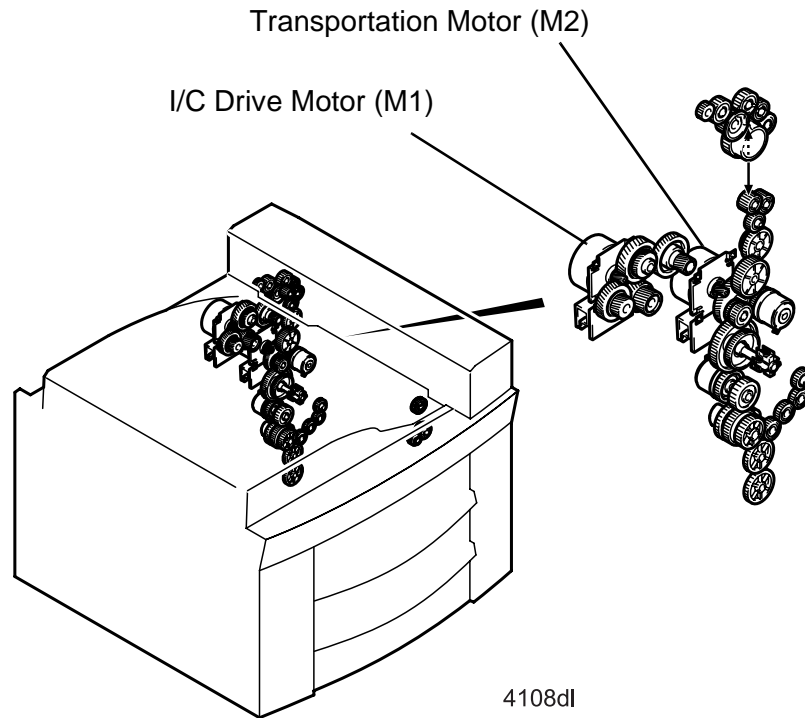

Figure 2-2. Gear/Roller Location

2.1.3 Electrical Component Layout

The electrical component layout is as shown below.

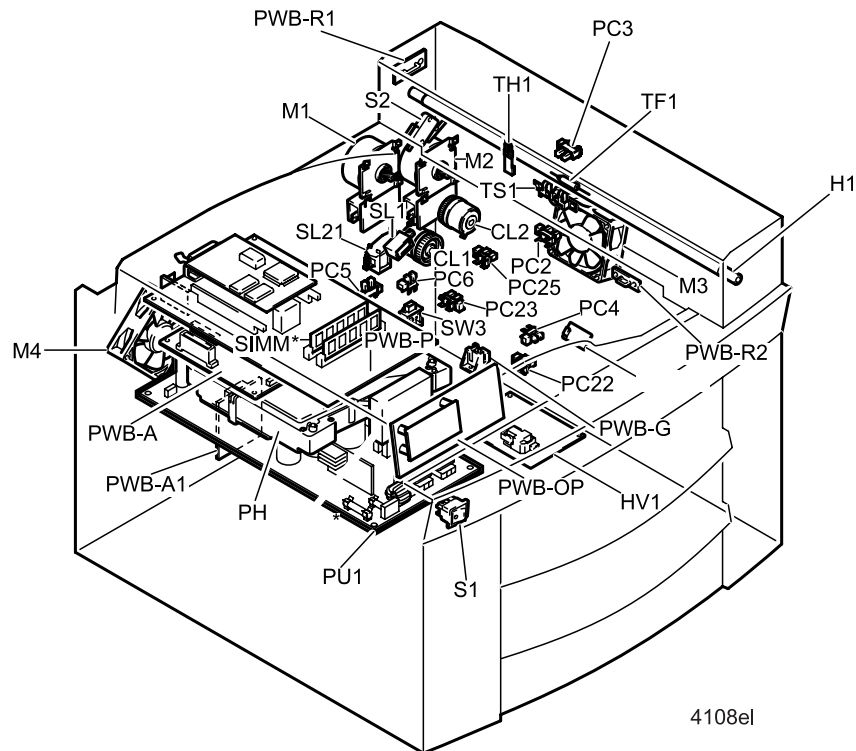

Figure 2-3. Electrical Component Layout

- PH: Print Head Unit
- CL2: Transport Clutch
- PU1: Power Supply Unit
- S1: Power Switch
- HV1: High Voltage Unit
- S2: Right Door Interlock Switch
- PWB-A: Main Board
- SW3: Cassette 1 Set Switch
- PWB-A2: Cassette 1 Main Board
- PWB-G: Toner Empty Detecting Board
- PWB-OP: Control Panel
- PWB-P: Controller Board
- PWB-R1: Fuser Frame Resistor Board
- PWB-R2: Pre-Transfer Guide Plate Resistor Board
- PC3: Paper Exit Sensor
- PC4: MP Cassette Paper Empty Sensor
- PC5: MP Cassette Paper Near Empty Sensor
- PC6: MP Cassette Set Sensor
- PC22: Cassette 1 Paper Empty Sensor
- PC23: Cassette 1 Side Door Detecting Sensor
- PC25: Cassette 1 Paper Near Empty Sensor
- M1: I/C Drive Motor
- H1: Fusing Roller Heater Lamp
- M2: Transport Motor
- TF1: Fusing Roller Heater Lamp Fuse
- M3: Cooling Fan Motor
- TH1: Fusing Roller Thermistor
- M4: Power Unit Cooling Fan Motor
- TS1: Fusing Roller Thermostat
- SL1: MP Cassette Paper Take-up Solenoid
- SL21: Cassette 1 Paper Take-up Solenoid
- CL1: Timing Clutch

2.1.3.1 Switches and Sensors

Table 2-1. Switches and Sensors

Location	Name	Function
Printer main body		
S1	Main Switch	Turns on/off power.
S2	Right Door Interlock Switch	Detects open-close condition of the right door. (The right door is opened when the imaging cartridge is replaced.)
PC2	Timing Roller Front Sensor	Detects the paper has been fed. Signal is LOW when paper is detected.
PC3	Paper Eject Sensor	Detects the paper has been output. Signal is Low when paper is detected.
PC4	MP Cassette Paper Empty Sensor	Detects the paper empty condition for the MP Cassette. Signal is HIGH when no paper is in the cassette.
PC5	MP Cassette Paper Near Empty Sensor	Detects the paper near empty condition for the MP Cassette. Signal is LOW when no paper is in the cassette.
PC6	MP Cassette Set Sensor	Detects the MP Cassette is installed. Signal is HIGH with the cassette installed.
PWB-1	MP Cassette Size Sensor	Detects the size of the paper set in the MP Cassette.
S3	MP Cassette Paper Size Sensor	Detects the size of the paper set in the MP Cassette is whether A4 or LETTER.
PWB-G	Toner Empty Sensor	Detects the toner empty condition for the imaging cartridge. Signal is LOW when the toner has run out.
TH1	Fuser Thermistor	Cuts off the voltage for the heater lamp when the upper fusing roller heats up abnormally.

Location	Name	Function
TS1	Fuser Thermostat	Cuts off the voltage for the heater lamp when the upper fusing roller heats up abnormally.
TF1	Fuser Temperature Fuse	The fuse is blown when the temperature of the upper fusing roller has risen abnormally.
Cassette 1		
PC22	Cassette 1 Paper Empty Sensor	Detects the paper empty condition for the Cassette 1. Signal is LOW when no paper is in the cassette.
PC25	Cassette 1 Paper Near Empty Sensor	Detects the paper near empty condition for the Cassette 1. Signal is LOW when no paper is in the cassette.
PC23	Cassette 1 Right Door Set Sensor	Detects open-close condition of the Cassette 1 right door. The signal is HIGH when the door is closed.

2.1.4 Paper Feeding Section

2.1.4.1 MP Tray

□ Paper feeding from MP Tray

The power is transmitted from the transport motor (M2) as follows to take up paper from the MP.

1) The transport motor (M2) turns counterclockwise → 2) The idle gear turns clockwise. → The MP Cassette paper take-up solenoid (SL1) turns ON. → 3) The paper take-up roller turns counterclockwise. → Paper is taken up.

NOTE: Note: The rotational direction is the one viewing from the front of the printer.

Double feed of paper in the MP cassette is prevented by the friction produced with the separator pad.

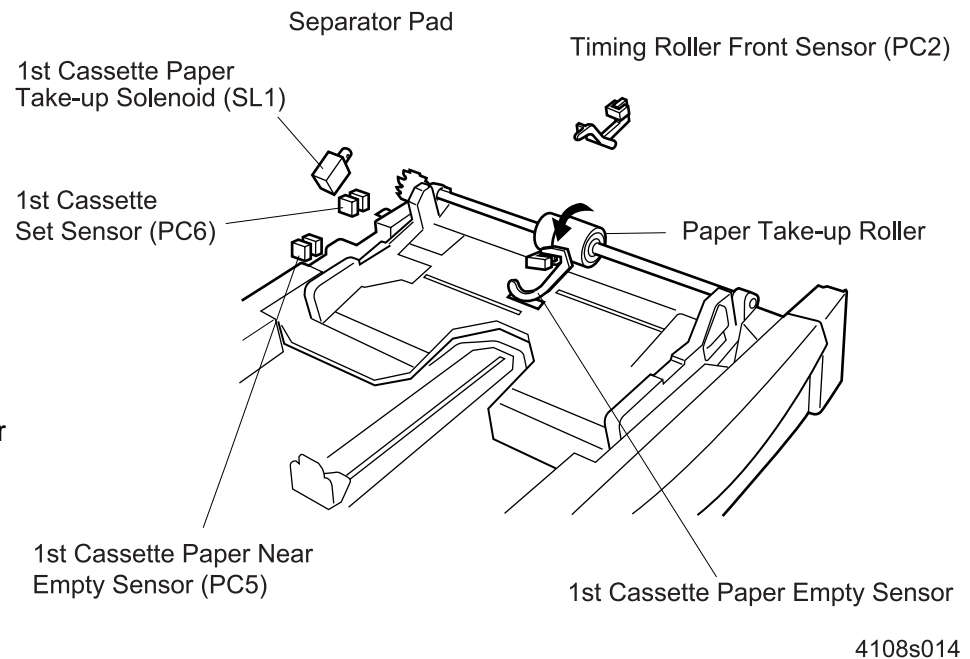
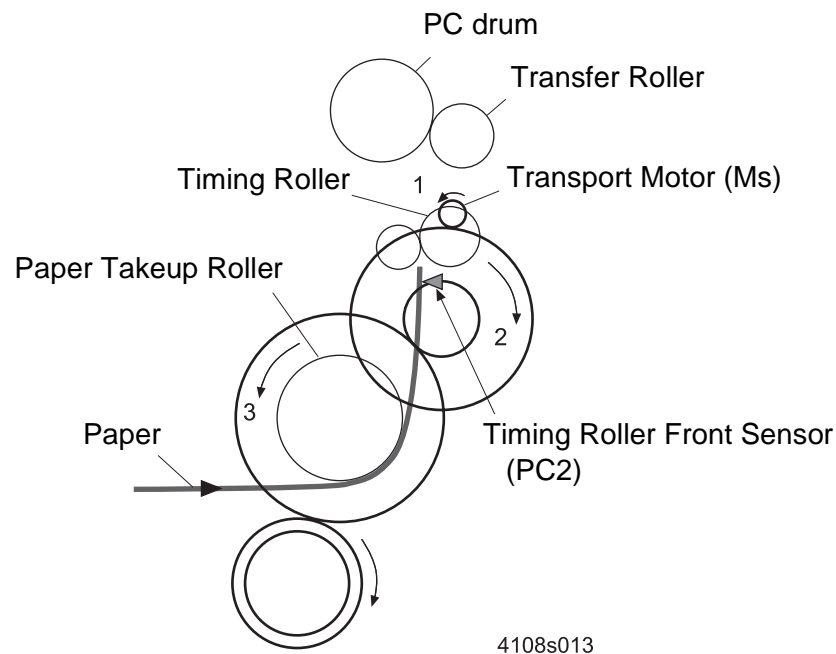

Figure 2-4. Paper Feeding Motion - MP Tray

□ MP Cassette Set Sensor (PC6)

This sensor detects the installation of the MP cassette. This sensor uses a photointerrupter. When the signal is input to the CPU in the control circuit, the CPU detects that the MP Cassette has been installed.

- If the MP cassette is not installed in the MP Tray:
The projection of the paper cassette comes off the sensor which is mounted on the printer. In this case, the light emitted from the LED of the photointerrupter reaches the phototransistor of the photointerrupter and the phototransistor turns ON. Accordingly, the output of the phototransistor, i.e., the output of the sensor is “L”.
- When the MP cassette is installed in the MP Tray:
The projection of the paper cassette engages with the sensor. In this case, the light emitted from the LED is blocked by the projecting and it does not reach the phototransistor. As a result, the phototransistor turns OFF and its output is “H”.

MP Cassette Set Sensor (PC6)

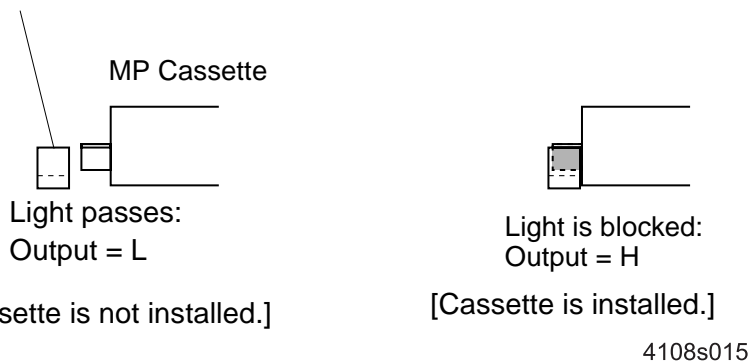

Note: PC6 is mounted on the Printer.

Figure 2-5. MP Cassette Set Sensor Mechanism

□ MP Cassette Paper Empty Sensor (PC4)

This sensor detects the paper empty status of the MP cassette. The sensor uses a photointerrupter. When paper runs out in the MP cassette, paper empty occurs.

When paper is present in the paper cassette, the lower part of the sensor arm is pressed by the paper and the projection of the upper part of the sensor arm comes off the photointerrupter. Thus, the light from the LED of the photointerrupter passes in the photointerrupter and the photointerrupter turns ON. As a result, the output of the photointerrupter is “L”.

When paper runs out in the paper cassette, the lower part of the sensor arm lowers with its weight so that the projection of the sensor arm engages with the photointerrupter. As a result, the output of the photointerrupter is “H”.

MP Cassette Paper Empty Sensor (PC4)

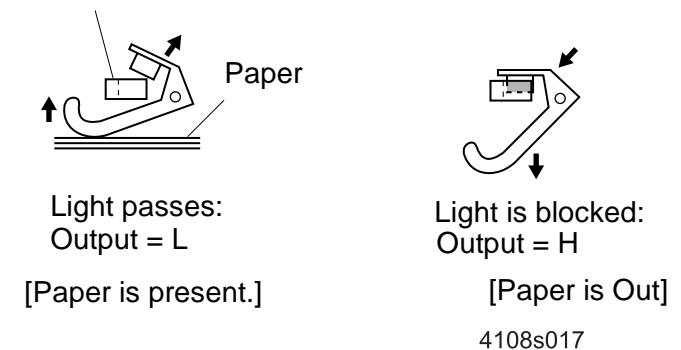

Figure 2-6. MP Cassette Empty Sensor Mechanism

□ (3) MP Cassette Paper Near Empty Sensor (PC5)

This sensor detects the paper near empty status of the MP Cassette paper. The sensor uses a photointerrupter. As the sheets of paper in the paper cassette decrease, the paper lifting plate in the paper cassette lifts. When the paper lifting plate lifts exceeding a certain point, the MP Cassette paper near empty occurs.

Paper near empty detection accuracy: 50 ± 30 sheets

- When enough paper is present in the paper cassette:
The paper lifting plate is lowered. In this condition, the lower part of the sensor arm is engaged with the photointerrupter. Thus, the light from the LED of the photointerrupter is blocked by the sensor arm and the photointerrupter turns OFF. As a result, the output of the photointerrupter is “H”.
- When the remainder of paper decreases:
The upper part of the sensor arm is pressed by the paper lifting plate and the lower part of the sensor arm comes off the photointerrupter. Thus, the light from the LED passes in the photointerrupter and the photointerrupter turns ON. As a result, the output of the photointerrupter is “L”.

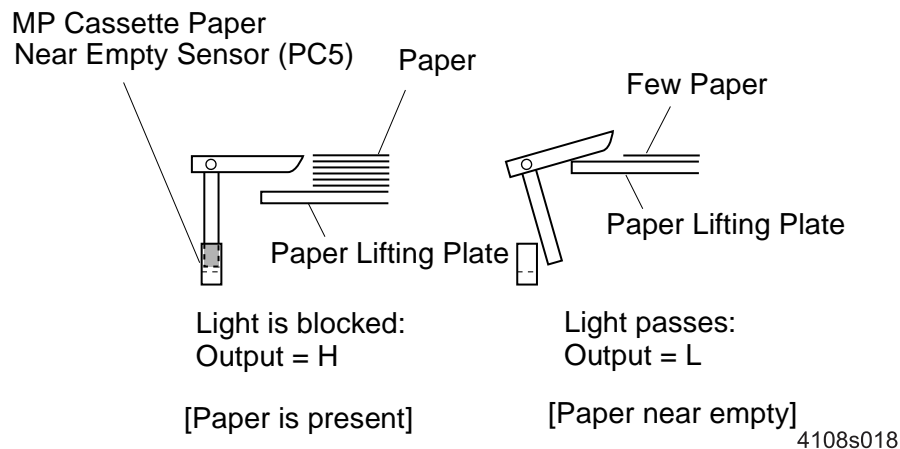

Figure 2-7. MP Cassette Paper Near Empty Sensor Mechanism

□ Timing Roller Front Sensor (PC2)

This sensor detects that the paper is fed inside the printer. The sensor uses a photointerrupter. The output of the sensor is used as a reference for feeding paper inside the printer. This sensor will be activated when paper is fed from any paper source.

- No paper is fed:
The sensor arm is pressed by a spring and the end of the sensor engages with the photointerrupter. As a result, the output of the photointerrupter is “H”.
- Paper is fed to the Timing Roller Front Sensor:
The sensor arm is pushed by the paper and the end of the sensor arm comes off the photointerrupter. As a result, the output of the photointerrupter is “L”.

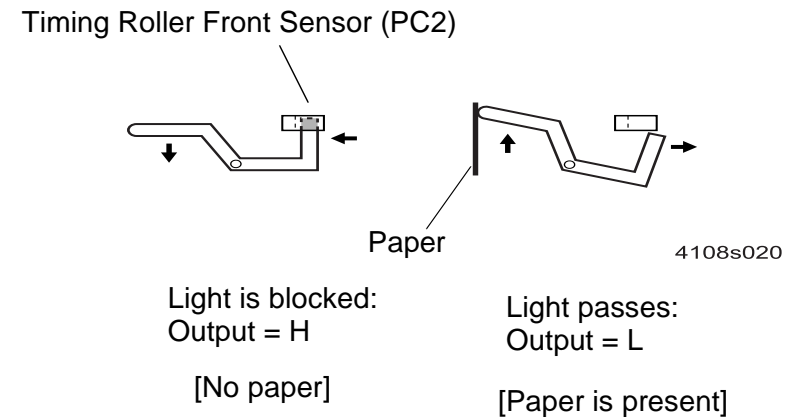

Figure 2-8. Timing Roller Sensor Mechanism

□ MP Cassette Size Sensor

The paper size for the MP cassette is detected by the rear paper guide. The paper size detection mechanism consists of the arm that joins with the rear paper guide and four mechanical switches in the printer body. When the rear paper guide is aligned with the paper size, the arm swivel accordingly, as shown below. The arm has a notch, which moves as the arm swivels to turn on/off the four mechanical switches. The paper size is determined according to the switches' on/off conditions.

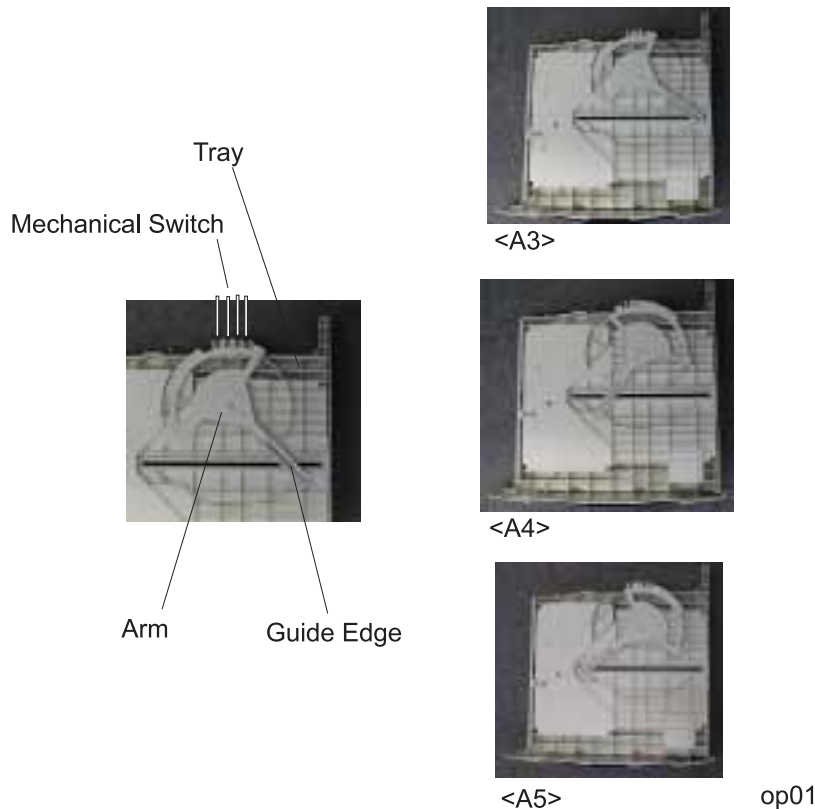

Figure 2-9. Paper Size Detection Mechanism

□ A4 / Letter Detection

The MP Cassette has the A4 / Letter detection mechanism. The mechanism consists of the right paper edge guide, the arm that engages/disengages with the right paper edge guide, and one mechanical switch that is installed in the printer main body. When the right and left paper guides are aligned with Letter size paper set in the cassette, the arm turns around. This motion switches the mechanical switch and Letter size paper is detected.

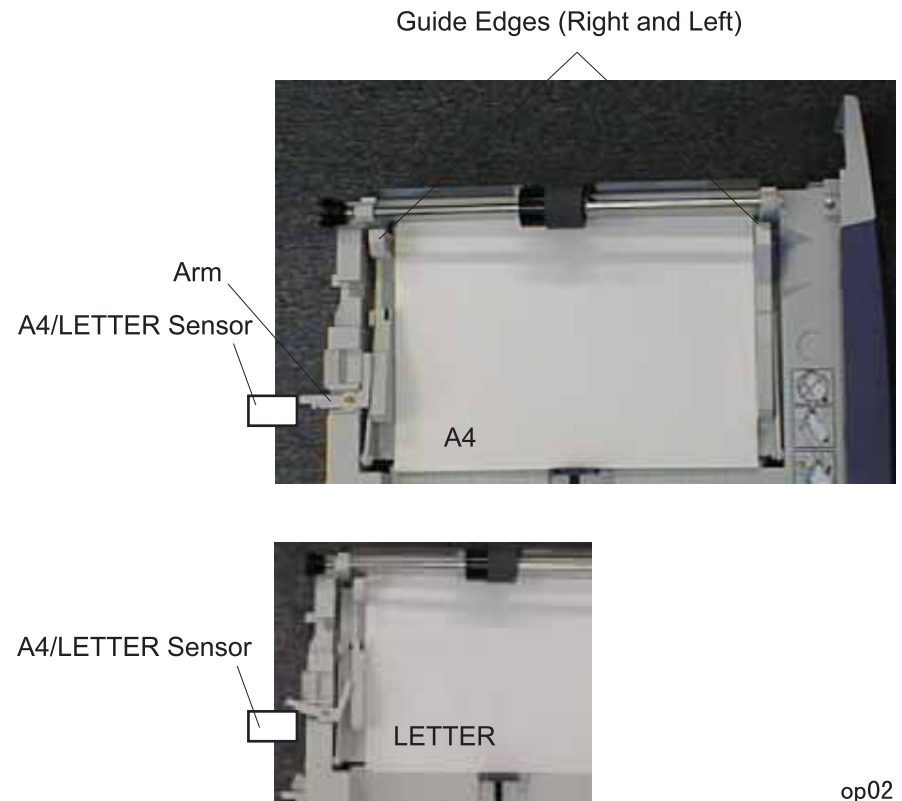

Figure 2-10. A4 / Letter Detection Mechanism

2.1.4.2 Cassette 1

□ Paper Feeding from Cassette 1

The power is transmitted from the transport motor (M2) as described on the right to take up paper from the Cassette 1.

1) The transport motor (M2) turns counterclockwise → 2) The idle gear turns clockwise. → 3) The MP Cassette paper take-up gear turns counterclockwise. → 4) The MP Cassette idle gear turns clockwise. The transport clutch (CL1) turns ON. → Power is transmitted to the Cassette 1. → The Cassette 1 paper take-up solenoid (SL21) turns ON. → 5) Paper Take-up Roller turns counterclockwise. → Paper is taken up. → 6) ~ 8) The gear train turns. → 9) The transport gear turns counterclockwise. → Paper is taken up. → Paper is fed

NOTE: The rotational direction is the one from the front of the printer.

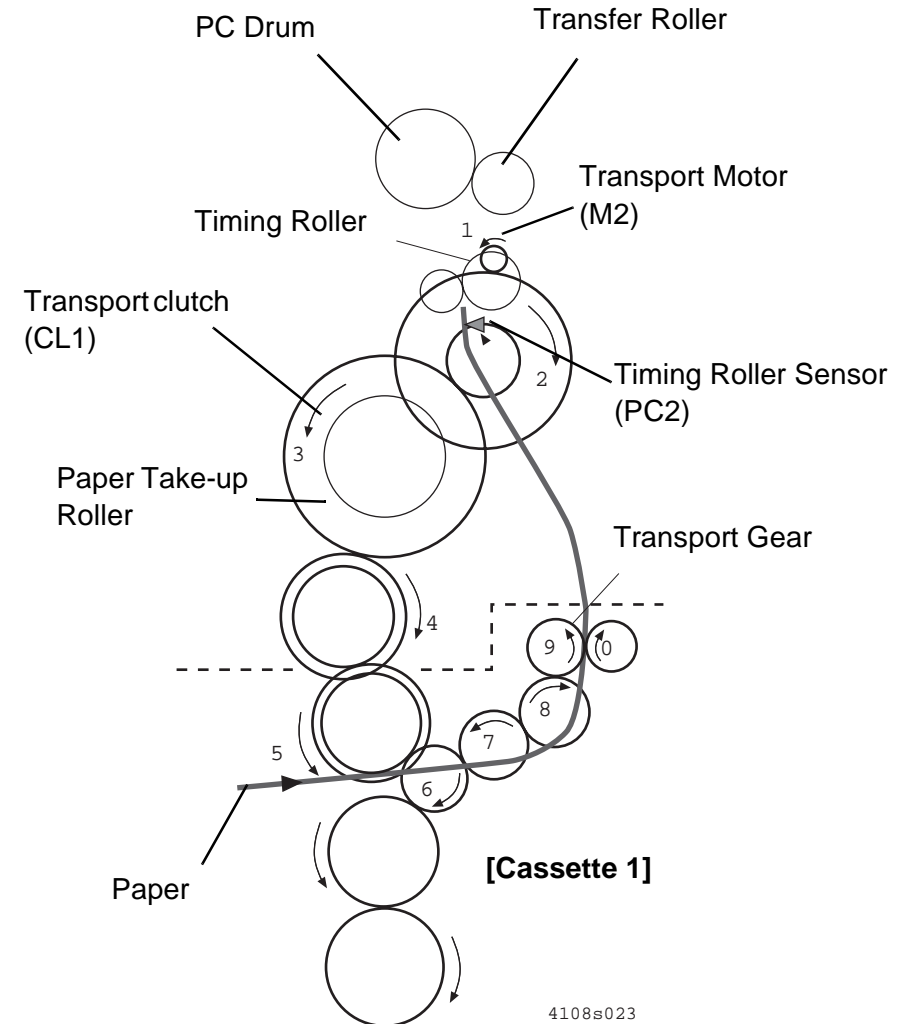

Figure 2-11. Cassette 1 Paper Path

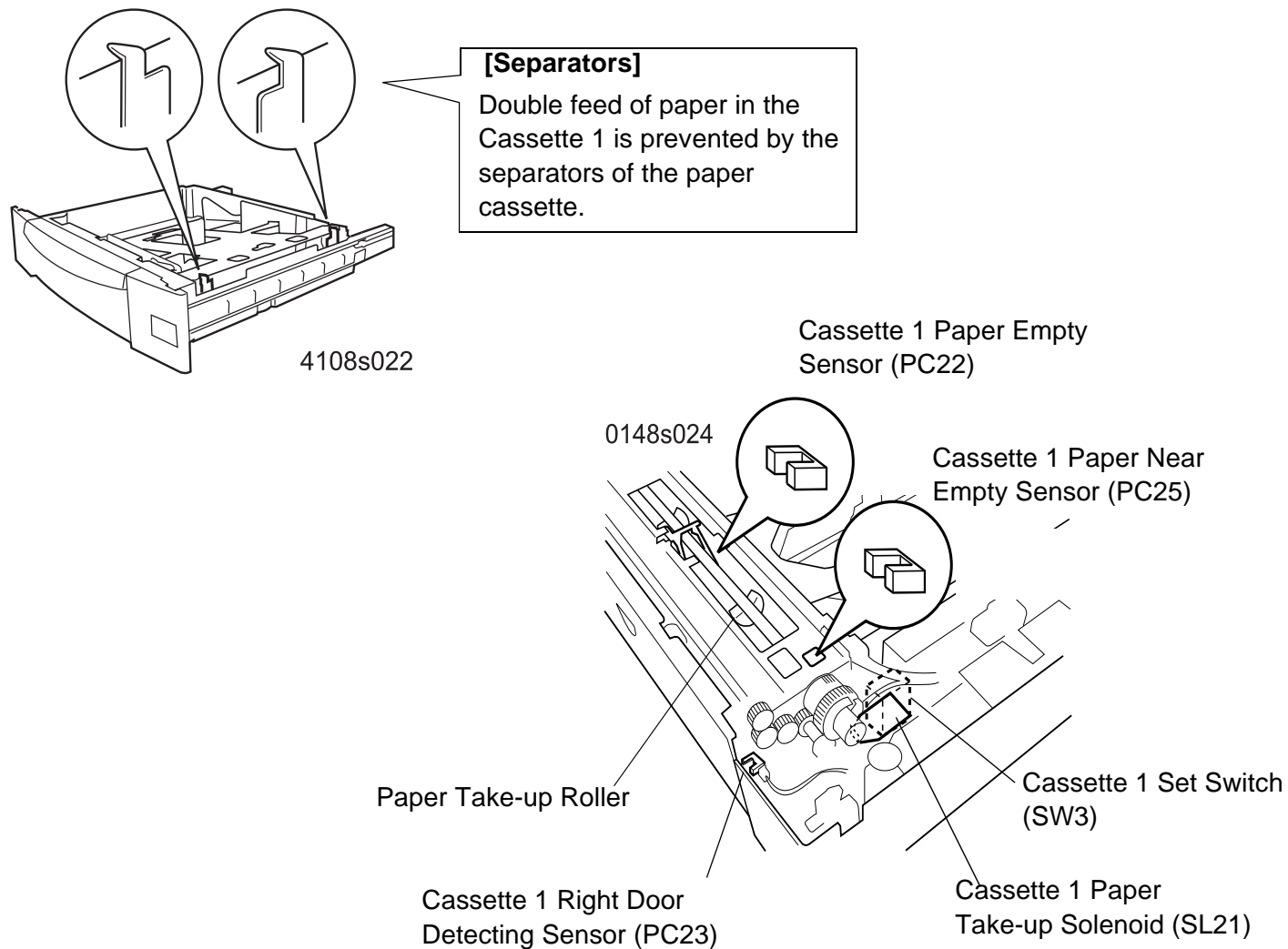

Figure 2-12. Cassette 1 Paper Feeding Mechanism

□ Cassette 1 Paper Size Sensor

A mechanical switch is installed to the Cassette 1 to set the size of the paper set. Unlike for the MP Cassette (MP Tray), the printer detects the paper size set in the Cassette 1 (all universal cassettes) by the paper size setting dial. Each notch on the setting dial corresponds to different paper size. When the dial is turned, the paper size sensor detects the notch for the corresponding paper size to determine the paper size set in the paper cassette.

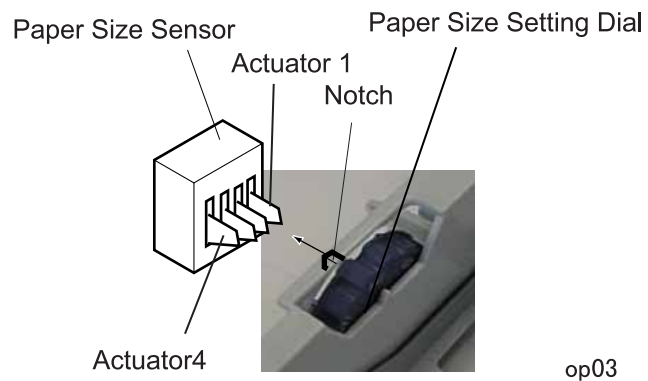

Figure 2-13. Cassette 1 Paper Size Detection

■ Paper Size Detection Sequence

The paper sizes and corresponding actuator conditions are as shown in the following table.

Table 2-2. Paper Size and Corresponding Actuator Condition

No.	Actuators				Paper Size
	4	3	2	1	
1	1	1	1	1	A3
2	1	1	0	1	Ledger (11 x 17")
3	1	1	0	0	A4 (LEF)*1
4	1	0	1	1	Legal
5	1	0	1	0	Letter
6	1	0	0	1	G-Letter
7	1	0	0	0	B4

*1: Long Edge First

□ Cassette 1 Paper Empty Sensor (PC22)

This sensor detects the paper empty status of the Cassette 1. The sensor uses a photointerrupter. When paper runs out in the Cassette 1, paper empty occurs.

- When paper is present in the paper cassette:
The sensor arm is pressed by the paper and it is lifted. So, the projection of the sensor arm engages with the photointerrupter. As a result, the output of the photointerrupter is “H”.
- When paper runs out in the paper cassette:
The sensor arm lowers by pressing a spring so that the projection of the sensor arm comes off the photointerrupter. As a result, the output of the photointerrupter is “L”.

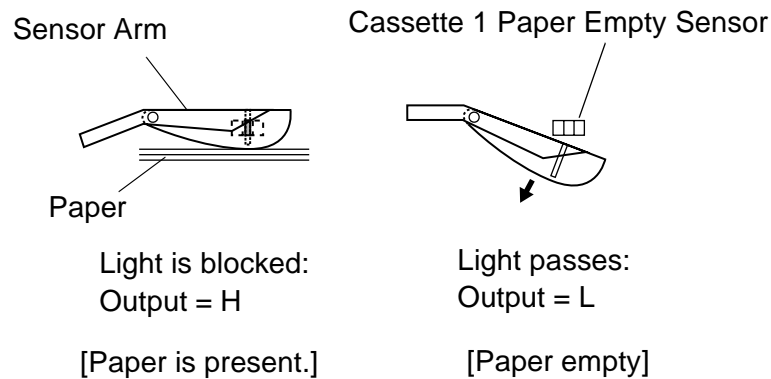

4108s026

Figure 2-14. Cassette 1 Paper Empty Sensor Mechanism

□ Cassette 1 Paper Near Empty Sensor (PC25)

This sensor detects the paper near empty status of the Cassette 1 paper. The sensor uses a photointerrupter. As the sheets of paper in the paper cassette decrease, the paper lifting plate in the paper cassette lifts. When the paper lifting plate lifts exceeding a certain point, the Cassette 1 paper near empty occurs.

- When enough paper is present in the paper cassette:
The paper lifting plate is lowered. In this condition, the projection of the sensor arm is engaged with the photointerrupter. Thus, the output of the photointerrupter is “H”.
- When the remainder of paper decreases:
The lower part of the sensor arm is pressed by the paper lifting plate and the projection of the sensor arm comes off the photointerrupter. Thus, the output of the photointerrupter is “L”.

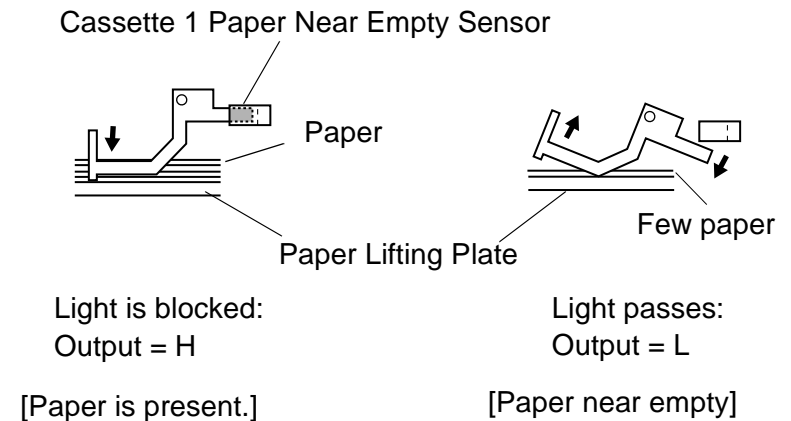

4108s027

Figure 2-15. Cassette 1 Paper Near Empty Sensor Mechanism

□ Cassette 1 Right Door Detecting Sensor (PC23)

This sensor detects whether the Cassette 1 right door is closed or not. The sensor uses a photointerrupter. The right door is normally closed except when removing jammed paper.

- When the right door is closed:
The projection of the side door engages with the photointerrupter of the Cassette 1. Thus, the output of the photointerrupter is “H”.
- When the right door is opened:
The projection of the side door comes off the photointerrupter. Thus, the output of the photointerrupter is “L”.

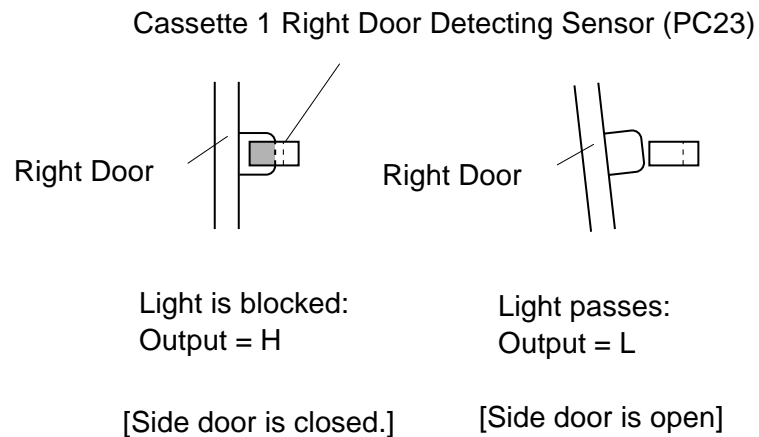

4108s028

Figure 2-16. Cassette 1 Right Door Detecting Sensor

2.1.4.3 Paper Feed

The paper taken up by the paper take-up section is fed to the transfer section after registration compensation.

□ Registration Compensation

To eliminate any paper slant (skew), registration compensation is made by controlling the rotating timing of the paper take-up roller and timing roller.

The taken up paper passes the timing roller sensor (PC2) and reaches the timing roller. At this moment, the printer delays turning timing of the timing roller for a moment. As a result, the leading edge of the paper is aligned with the timing roller, eliminating any skew. The leading edge of the paper will slack a little as shown in the figure. Next, the timing clutch (CL1) is activated for feeding the paper to the inside of the printer. At the same time, the paper take-up roller turns for a moment to securely feed the paper.

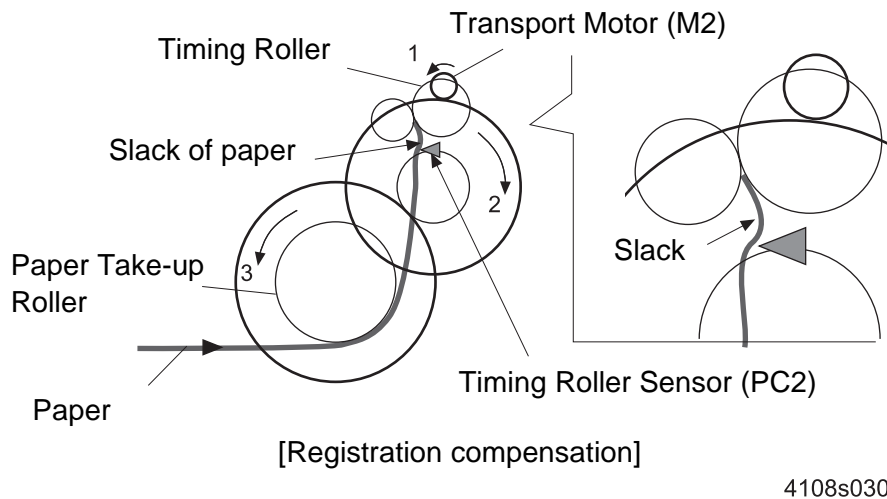

Figure 2-17. Registration Compensation

□ Paper Feeding

When the timing clutch (CL1) is activated, torque is transmitted to the timing roller from the transport motor (M2) as follows and the paper is fed to the transfer section.

1) The transport motor (M2) turns counterclockwise. → 2) The idle gear turns clockwise. The timing clutch (CL1) turns ON. → 3) The idle gear turns counterclockwise. → 4) The timing roller turns clockwise. → Paper is fed.

The PC drum is driven by the I/C drive motor (M1). As the PC drum turns, the transfer roller also turns. Accordingly, the paper fed by the timing roller is pinched by the PC drum and transfer roller for feeding to the fusing section.

■ Retry of paper feeding

If the timing roller front sensor does not detect the fed paper within certain time, paper feeding is performed again.

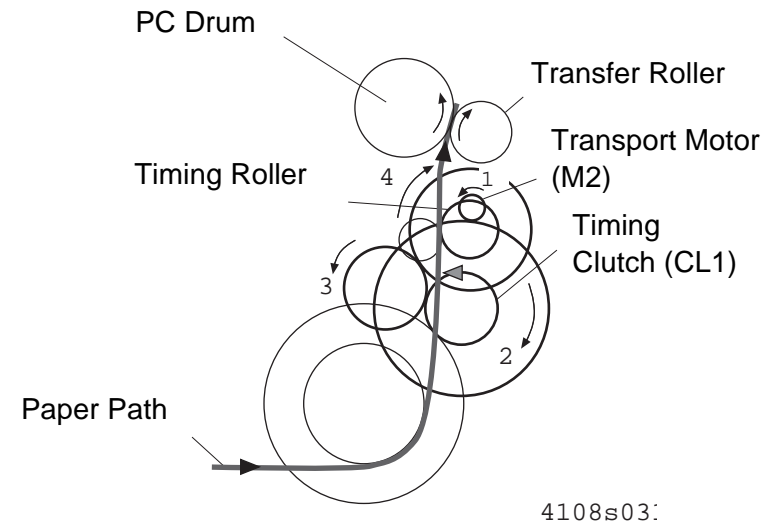
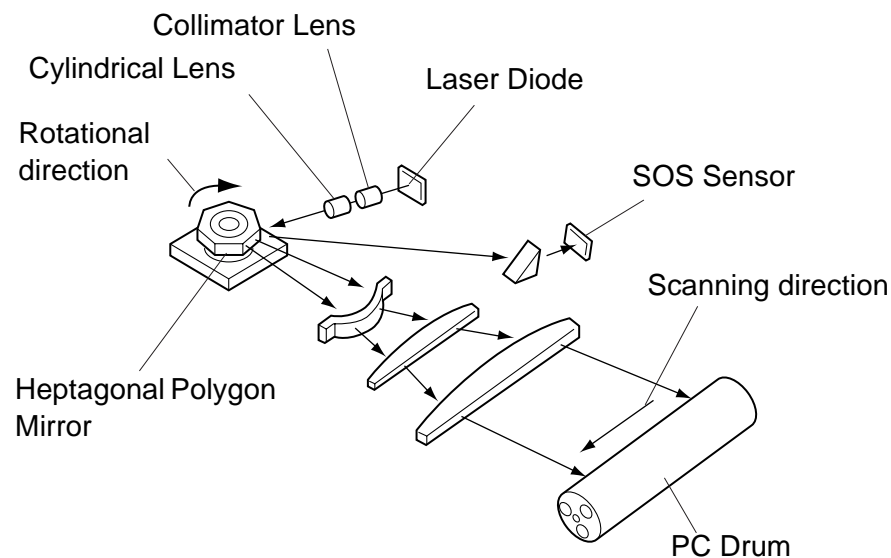

Figure 2-18. Paper Feeding Mechanism

2.1.5 Printhead Unit (Exposure Section)

The print head unit incorporates a laser diode that emits the laser beam corresponding to the print image data. The spot of the laser beam emitted from the laser diode is shaped in a circle through the collimator lens. Then, it is applied to the heptagonal polygon mirror via the cylindrical lens. The polygon mirror is turned by the polygon motor in the direction as shown by the arrow.

The reflected laser beam by the rotating polygon mirror passes the three lenses, producing a parallel scanning laser beam. The scanning laser beam scans on the PC drum from left to right for producing an electrostatic latent image on the surface of the PC drum.



4108s032

Figure 2-19. Printhead Unit Mechanism

□ Operation of the SOS Sensor

To maintain the printing density constant, it is required to emit a laser beam at constant laser power. To control the laser power to be constant is called APC (Automatic Power Control).

The SOS sensor incorporated in the print head unit is used to detect whether the laser power reaches certain laser power for printing. The SOS sensor is located outside of the printing area. When printing starts, it takes 1 or 2 scans to obtain the SOS sensor output. During printing, the SOS sensor output is monitored in every scanning for controlling the laser power constant.

2.1.5.1 Print Process Sequence

The print process sequence is as shown in the following figure.
For details, See Section 2.1.5.1

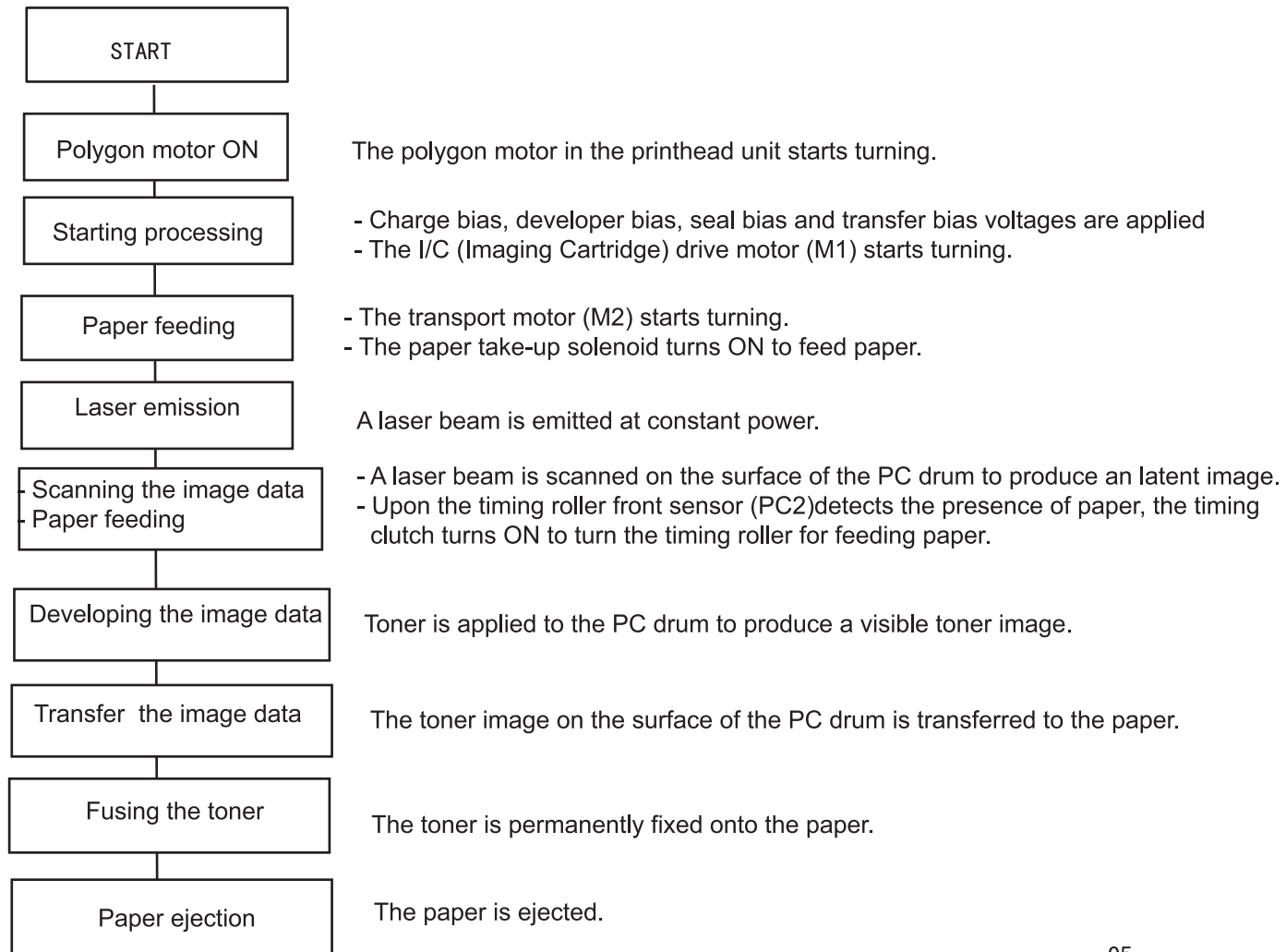

op05

Figure 2-20. Print Process Sequence

2.1.6 Imaging Cartridge

2.1.6.1 Part Names and Functions of the Imaging Cartridge

The following illustrates the construction of the imaging cartridge. The power to the gears of the imaging cartridge is transmitted from the I/C drive motor (M1) of the printer main body. The I/C drive motor (M1) turns clockwise viewing from the front of the printer.

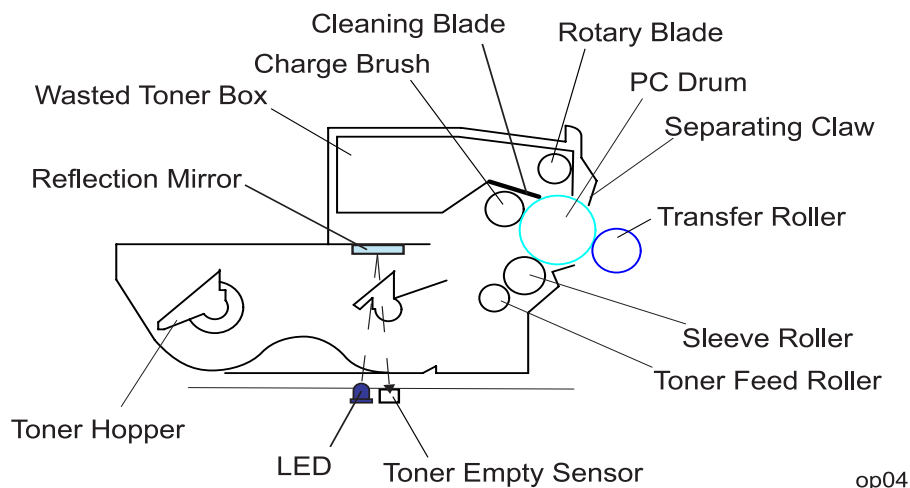

Figure 2-21. Imaging Cartridge

- Sleeve Roller: Feeds toner to the electrostatic latent image formed on the surface of the PC drum to produce a visible toner image.
- Transfer Roller: Transfers the toner image on the surface of the PC drum onto the paper. (The transfer roller is not incorporated in the imaging cartridge.)
- Separating Claw: Securely separates the paper from the PC drum.
- Cleaning Blade: Cleans off the toner remaining on the surface of the PC drum.
- Rotary Blade: Feeds the wasted toner to the wasted toner box.
- Toner Empty Sensor: Detects a toner-empty status. (The toner empty sensor is not incorporated in the imaging cartridge.) The sensor unit consists of the LED and the sensor. Light emitted from the LED is reflected by the reflection mirror built in the imaging cartridge and then detected by the sensor. The sensor monitors the toner's empty/near empty condition by referring to the voltage level, pulse width, and detected times of the detection signal.

op04

- Charge Brush: Charges the PC Drum. By using the brush, less ozone is emitted.
- Toner Hopper: Agitates toner with the two agitator blade to feed toner to the toner feed roller.
- Toner Feed Roller: Feeds toner to the sleeve roller.

2.1.6.2 Charging Section

Before producing an electrostatic latent image on the surface of the PC drum with a laser beam, the PC drum is charged by static electricity with the rotating charge bush so that the surface of the PC drum is negatively charged. The charging system uses the rotating charge brush system. Since this charging system can apply charge directly to the PC drum, charging is possible at a low voltage, producing negligible amount of ozone.

The negative level of the surface of the PC drum will be reduced when a laser beam is applied. (Negative voltage level reduces.)

NOTE: Note: For the laser beam emission, see Section 2.1.5 "Print Head Unit (Exposure Section)".

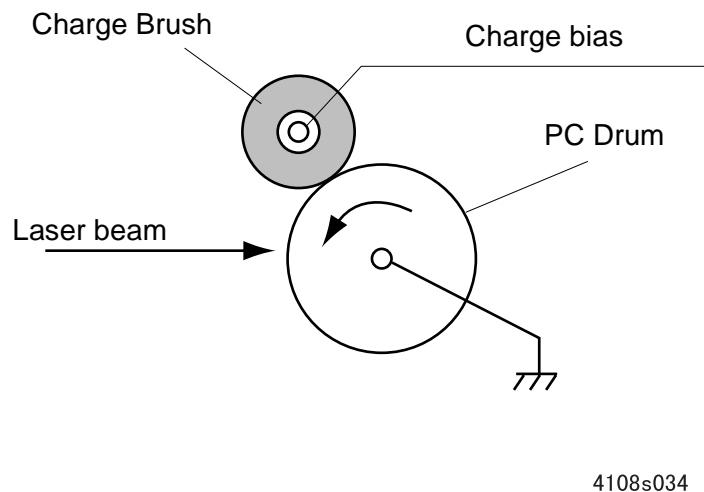

Figure 2-22. Charging Section Mechanism

2.1.6.3 Development Section

The development section feeds toner to the electrostatic latent image on the surface of the PC drum to produce a visible toner image. The toner in the toner hopper is agitated by the two agitator blades to feed toner to the toner feed roller. Then, the toner is fed to the sleeve roller which is negatively biased. Accordingly, the toner is negatively charged by the sleeve roller. The toner regulating plates acts to regulate the amount of toner fed to the sleeve roller. To regulate the toner, a voltage lower than the sleeve roller is applied to the toner regulating plates.

Since the toner is negatively charged by the sleeve roller, the toner will stick to the electrostatic latent image where the negative voltage is reduced. On the other hand, toner does not stick to the part where no laser beam is applied since the part maintains the negatively charged voltage with the charge brush.

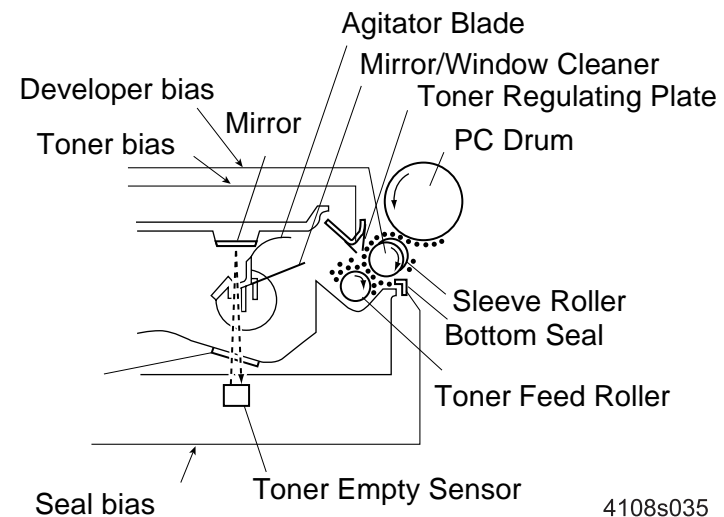
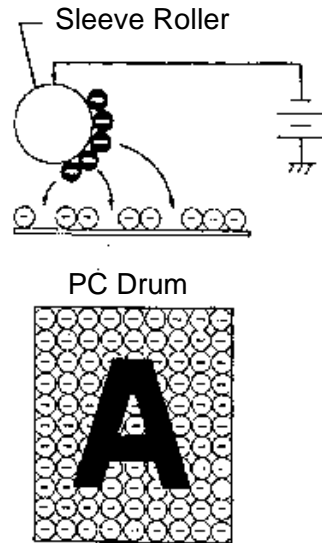

Figure 2-23. Development Section

The following illustrates an example where the letter “A” is written by the laser beam and toner sticks onto the letter “A” on the surface of the PC drum.



4108s036

Figure 2-24. Toner Image Production

The seal beneath the sleeve roller acts to discharge the negatively-charged unused-toner on the sleeve roller. The discharged toner is fed back to the toner feed roller for recycling it. Note that, during printing, the seal voltage is the same as the sleeve roller voltage and discharge is not made. However, before and after printing, the voltage of the seal bias is set 100V higher than that of the sleeve roller to discharge the unused toner for recycling.

□ Operation of the Toner Empty Sensor:

The toner empty sensor detects the toner-empty status. The sensor is a photo reflector mounted on the printer.

If low toner condition occurs, the light emitted from the LED of the photo reflector passes the window of the toner hopper and reflected by the mirror. The reflected light reaches the phototransistor of the photo reflector and the phototransistor turns ON. Thus, the sensor output is “L” when the toner is empty.

In actual fact, detection of the toner empty is a little more complicate. Since toner in the hopper is agitated with the agitator blades, toner empty cannot be detected like the ON/OFF status of a switch. The rotating mirror/window blade cleans the mirror and window repeatedly. Basically, the CPU on the main board judges that the toner near empty occurred when a low toner condition has been detected by a certain number of times while the mirror/window blade has been rotated by a certain number of times. Next, the CPU judges that the toner empty occurred when thus detected toner near empty has been counted by a certain number of times. If toner empty is detected, printing becomes impossible.

2.1.6.4 Transfer Section

The transfer roller transfers the toner image on the surface of the PC drum onto the paper. A positive transfer bias is applied to the transfer roller so that the toner (reduced negative voltage) on the surface of the PC drum sticks to the paper.

The transfer bias is transmitted via; HV transformer (high voltage unit) → contact plate → compression spring → transfer roller bushing → transfer roller.

For constant image quality, the engine controller manages changes voltage (around 20 μ A) depending on the paper type and color duty (black and white).

The paper then passes through the needle pole and the static electricity remaining on the paper is discharged to the ground. This enables forcible separation of the paper from the PC drum.

After the transfer roller, the paper passes discharging pole. The discharging pole prevents the toner from moving due to discharge electricity produced while paper is separated from the transfer roller.

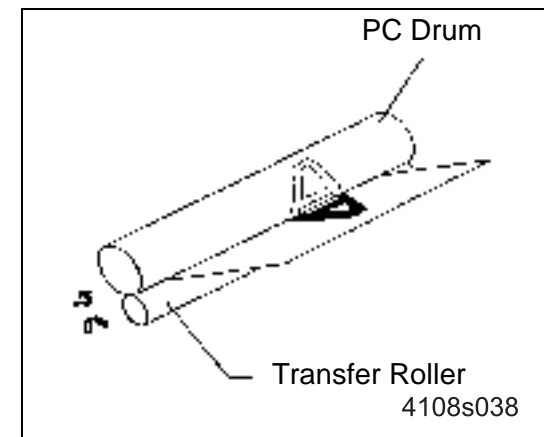
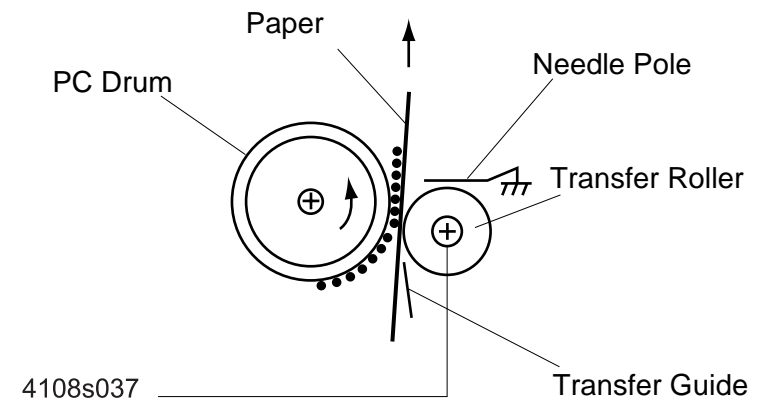

Figure 2-25. Transfer Section Mechanism

2.1.6.5 Fusing Section

The power from the transport motor (M2) is transmitted to the upper fusing roller so that the toner-transferred paper is fed from the transfer section to the fusing section.

The paper is heated to melt the toner by the upper fusing roller and pressed by the upper and lower fusing rollers. The upper fusing roller is heated by the fusing roller heater lamp (H1) which is built in it. The fusing roller thermistor (TH1) is attached to the upper fusing roller for controlling the heater temperature. Also, the fusing roller thermostat (TH1) and fusing roller heater lamp fuse (TF1) are attached to the upper fusing roller as shown on the next page. The thermostat (TH1) and lamp fuse (TF1) are connected in series to the heater lamp (H1). The heater lamp (H1) is heated when an AC voltage is applied.

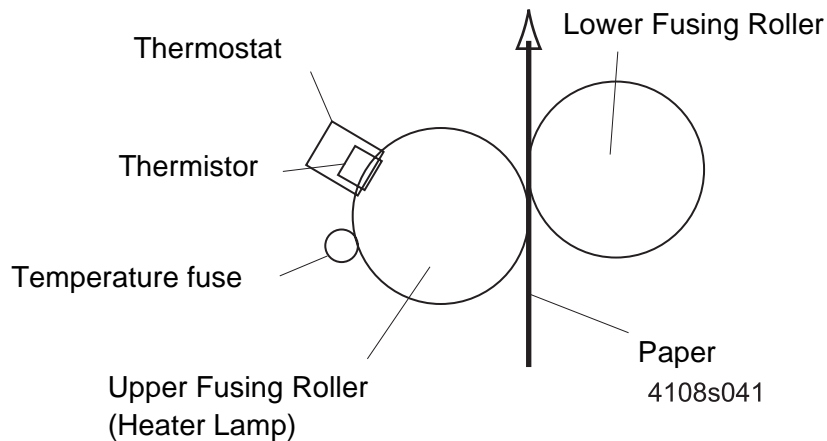

Figure 2-26. Fusing Section

- Temperature control using the thermistor

The resistance of the thermistor (TH1) attached to the upper fusing roller varies with temperatures. When temperature rises, the resistance of the thermistor (TH1) decreases, and vice versa. As shown in the circuit diagram, the thermistor output is connected to an analog port of the CPU on the main board.

The input level to the analog port of the CPU decreases as the temperature rises. The CPU performs A/D (Analog-to-Digital) conversion for the input level to know the current temperature. To heat the upper fusing roller, the CPU set the Heater Remote 1 output to ON ("L") state. Then, the triac on the power supply unit turns ON and an AC voltage is applied to the fusing roller heater lamp (H1) and the upper fusing roller is heated. The CPU monitors the output from the thermistor and controls ON/OFF of the triac to control the temperature of the upper fusing roller.

When the upper fusing roller temperature becomes abnormal and the output from the thermistor lowers than the predetermined level, the abnormal-heater-temperature detecting circuit is activated and the triac is forcibly turned OFF, resulting in shutting off an AC voltage application to the heater lamp.

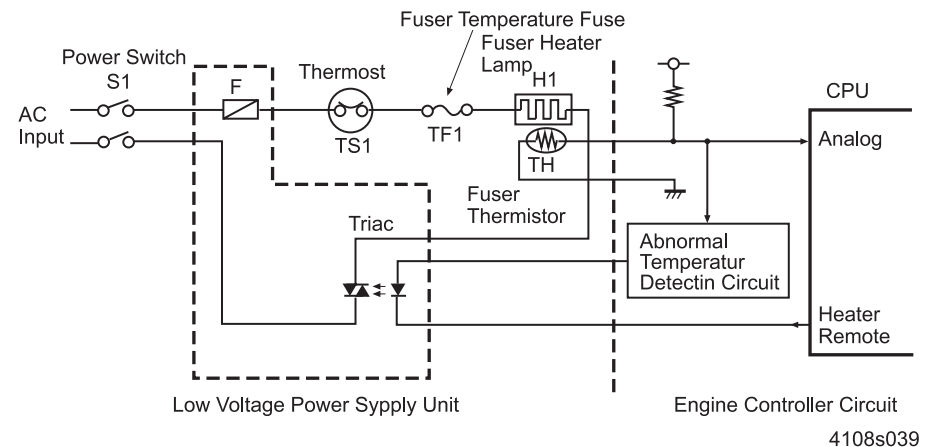

Figure 2-27. Temperature Control Using the Thermistor

- Rush current preventing circuit for heater lamp
To prevent rush current when an AC voltage is applied to the heater lamp, the CPU turns off the Remote 1 signal and turns on the Remote 2 signal in the form of pulse. By outputting Remote 2, the additional resistor is connected in series to the heater lamp to suppress the rush current flowing into the heater lamp.
- Thermostat (TS1) and heater lamp fuse (TF1)
If an abnormal current flows into the heater lamp because of thermistor trouble, etc. and the upper fusing roller temperature reaches about 220°C, the contact of the thermostat automatically opens to shut off an AC voltage. (As the temperature decreases, the contact of the thermostat closes again. However, once the thermostat has been activated, it must be replaced with new one.)
When a large abnormal current suddenly flows into the heater lamp, since the thermostat cannot respond quickly, the heater lamp fuse is blown to protect the heater lamp.

- Fusing temperature control

1. When the main switch is turned ON, the fuser starts warm-up until the upper fusing roller temperature reaches approximately 200°C. (It will take about one minute.)
2. To maintain the upper fusing roller temperature above 190°C, the control circuit raises the temperature and keeps at approximately 210°C for approximately five minutes. (Mode 1)
3. The control circuit gradually decreases the temperature by 190°C in five minutes. (Mode 2)
4. Preparing for printing, the control circuit keeps the upper fusing roller temperature at approximately 190°C. (Mode 3)
5. While the printer is in the idle status, the control circuits maintain the temperature at 180 °C.
6. In energy saving mode, the control circuit turns OFF the heater lamp.

NOTE: 190°C --> 183°C for overseas versions (TBD)

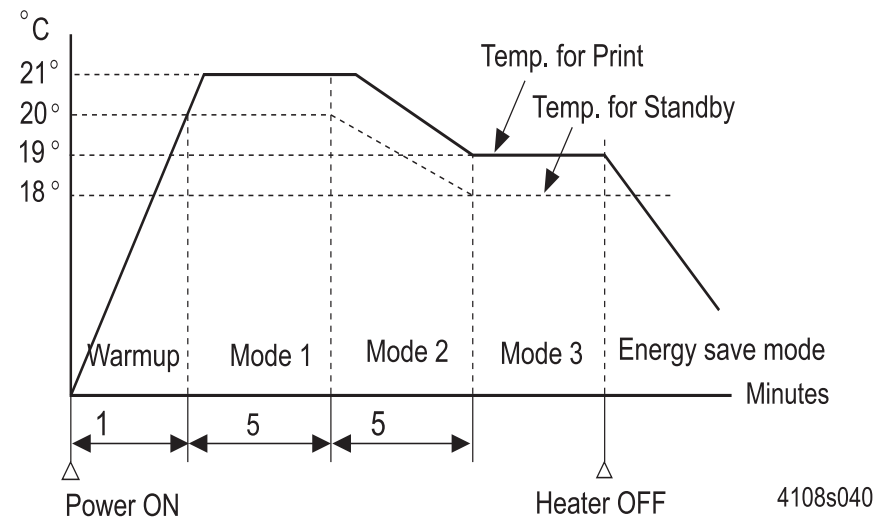

Figure 2-28. Fuser Temperature Control

- Fuser temperature control depending on the paper type
 - Normal paper:190°C
 - Special paper (thick paper):200°C
 - OHP:180°C
- PPM (Print Per Minute) control
When the printer prints on more than specified number of paper whose width is 250 mm or less, the temperature of the fuser rises by its edge areas. To avoid abnormal rise of the temperature, the printer prints with larger intervals than normal. (Print speed reduces.) When the interval is more than 2 minutes, the printer release the PPM control.
 - In Mode 3:After 1000 sheets, PPM control is activated.
 - In Mode 1 or 2:After 30 sheets, PPM control is activated.

2.1.6.6 Paper Exit Section

The paper fed from the fusing section passes through the paper exit roller and ejected to the output tray. The transmit power for feeding paper is given by the transport motor (M2) and transmitted in the order from 1) ~ 12) shown in the figure.

When the duplex unit is installed, however, drive from the fusing section is mechanically cut off, and the duplex unit is driven by the internal motor of the unit. This is performed to eject the paper temporarily and then switch back the paper for duplex printing.

The paper exit sensor (PC3) detects ejection of paper. This sensor uses a photointerrupter. During paper is passing through the sensor, the sensor arm is pressed by the paper so that the end of the sensor arm engages with the photointerrupter. In this condition, the output of the photointerrupter is "H".

When paper has passed the sensor, the sensor arm returns to the original position by spring force so that the end of the sensor arm comes off the photointerrupter. As a result, the output of the photointerrupter is "L".

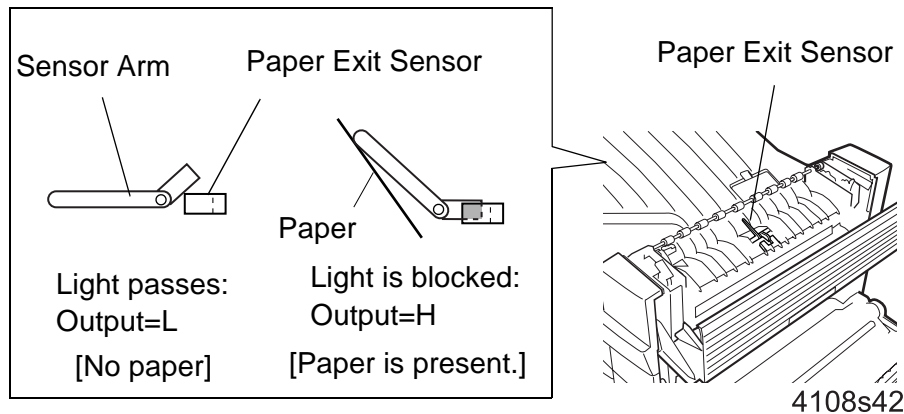

Figure 2-29. Paper Exit Sensor Mechanism

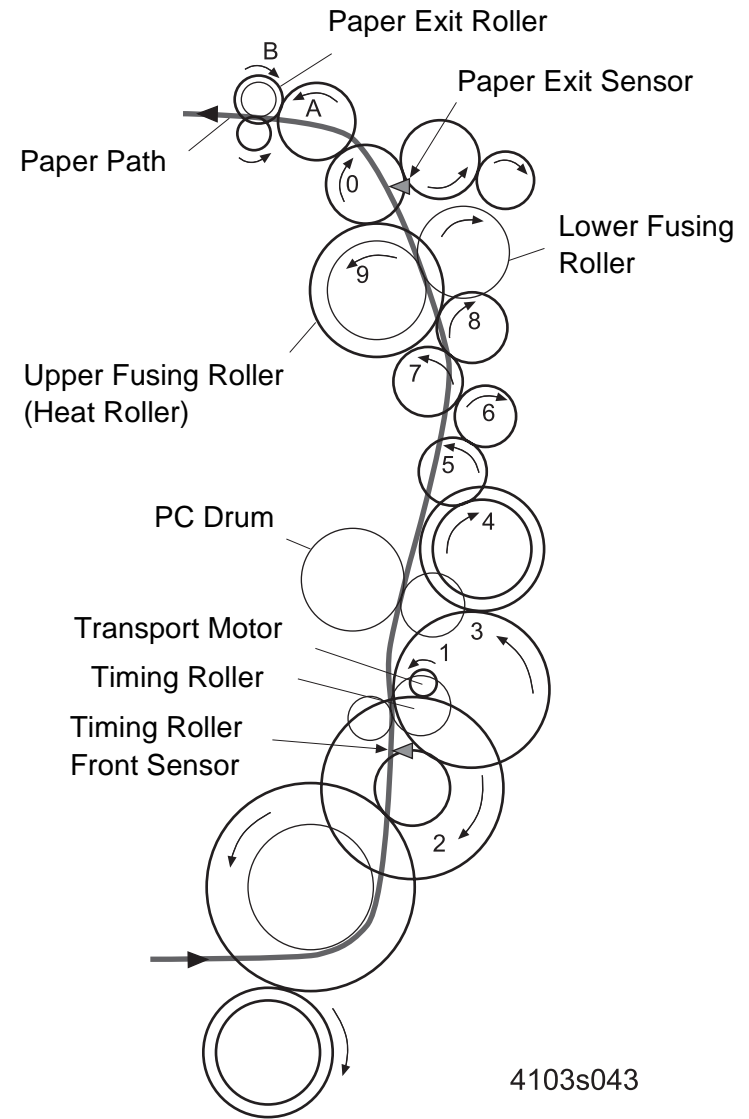

Figure 2-30. Paper Exit Mechanism

2.1.7 Detection whether New or Used Imaging Cartridge

The printer has the function to detect whether the newly installed imaging cartridge is a new one or used one. This function is equipped because the PC drum counter has to be reset when the imaging cartridge is replaced with a new one. As shown in the figure below, a fuse is connected in parallel with a resistor. In a new imaging cartridge, the fuse is not blown. Accordingly, by measuring the voltage across the resistor, the printer can determine whether the imaging cartridge is a new one or not.

When the printer is turned ON after a new imaging cartridge has been installed (or the right door has been closed after the imaging cartridge is replaced), the fuse is blown. When the fuse has been blown, the PC drum counter is cleared to enable detection of the image cartridge life. A resistor is used for the counter and when power is turned OFF, counter value, including other values, are stored in the EEPROM in the imaging cartridge. When power is turned ON, the counter value is recalled from the EEPROM from the imaging cartridge for continuing counting.

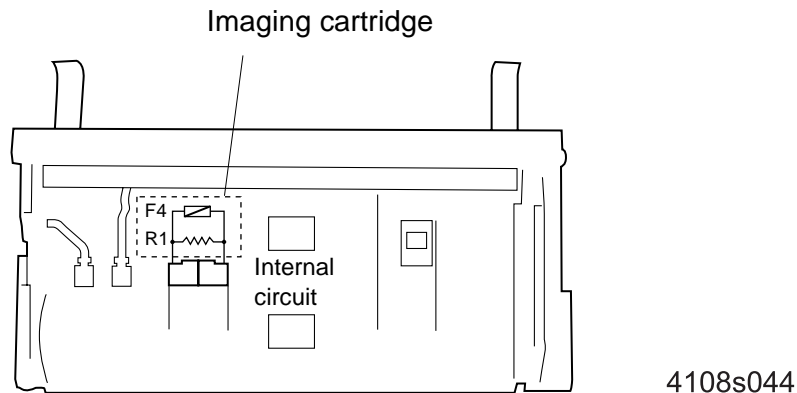

Figure 2-31. Internal Circuit of the Imaging Cartridge

NOTE: The counter is reset despite the fuse is not blown for some reason.

2.1.8 Right Door Interlock Switch

The right door is normally closed. It will be opened when the imaging cartridge is replaced or jammed paper is removed.

- When the door is open:
The door closed, the projection of the right door presses the switch lever via the spring linked with the switch lever and the switch is ON.
- When it is opened:
The lever of the switch is set free so that the switch is OFF.

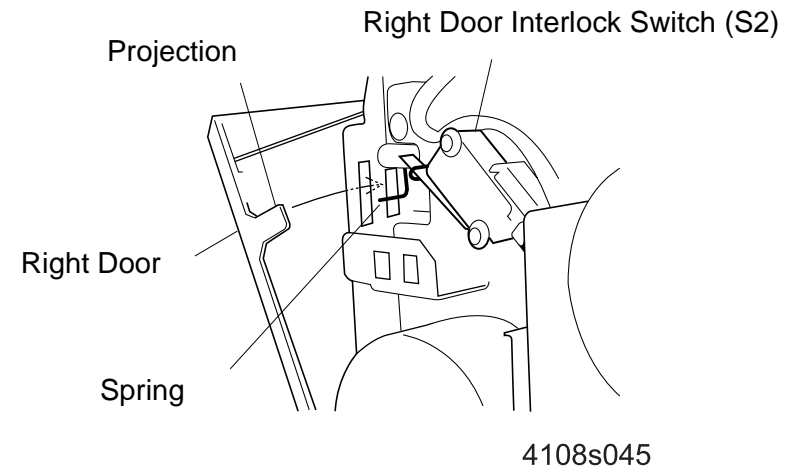

Figure 2-32. Right Door Interlock Switch

2.2 Electrical Circuit Operating Principles.

2.2.1 System Layout

2.2.1.1 Drive Section

The figure below shows the drive mechanism that consists of the motors, solenoids, clutch, rollers, and sensors

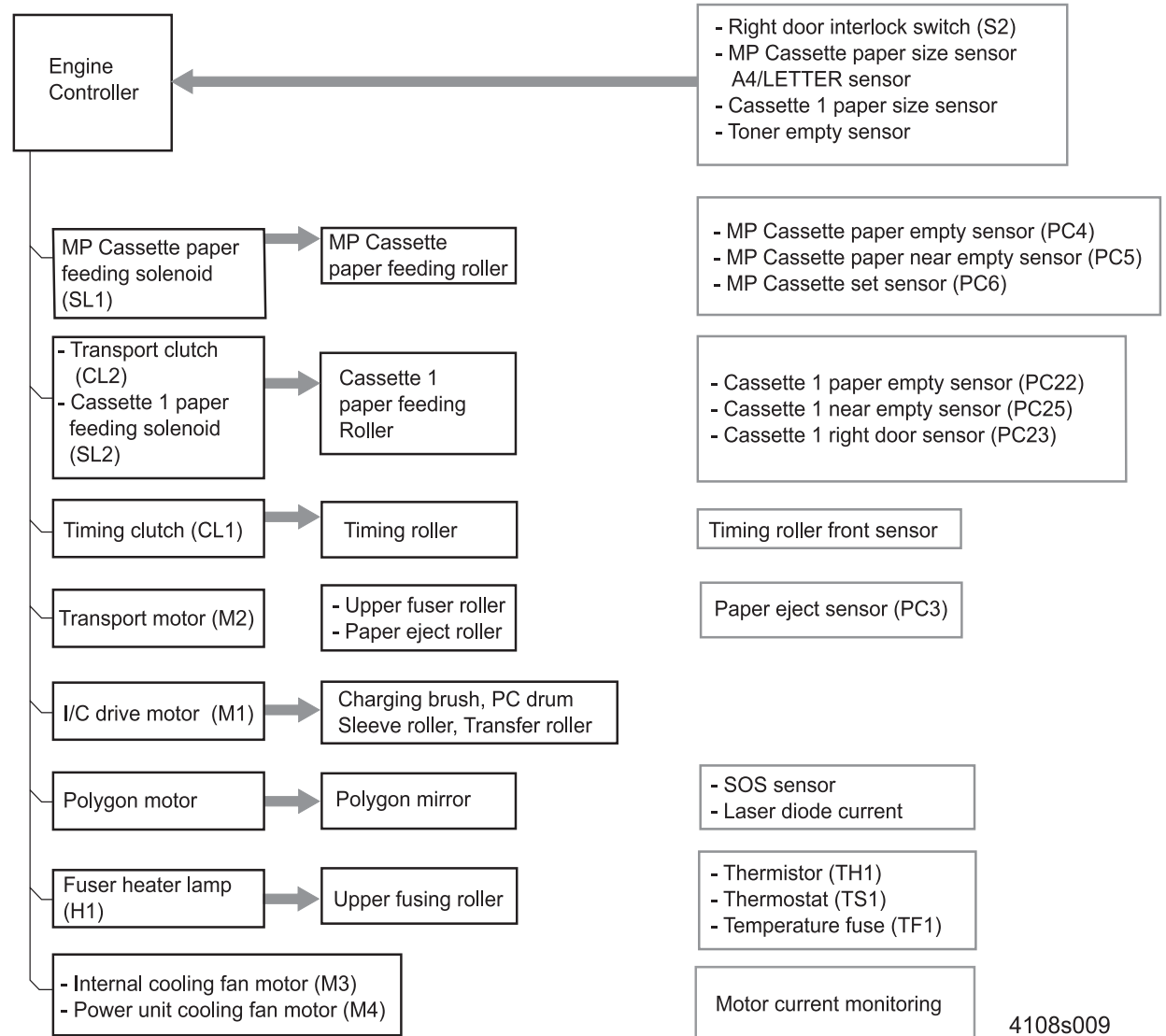

4108s009

Figure 2-33. System Layout - Drive Section

2.2.1.2 Electrical Section

The power supply system and the signal lines are shown below.

- The power supply unit supplies DC +5 V and DC +24 V to the main control board. It also supply an AC voltage to the heater lamp.
- The main controller (video controller) receives a compressed print data from the host PC through an interface.
- The main circuit generates image data.
- The image data is sent to the print head unit via the engine control board.
- The engine controller board manages the various parts of the engine including the paper take-up section, development section, transfer section, and fusing section.

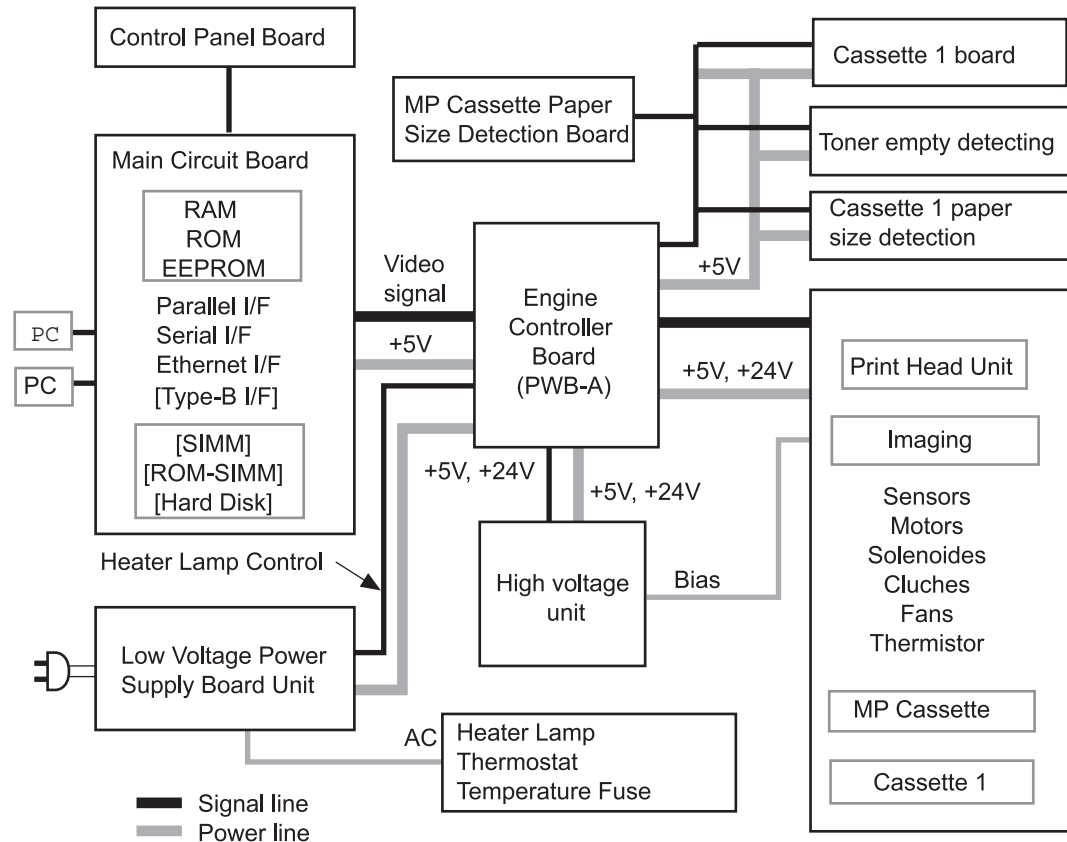

4108s010

Figure 2-33. System Layout - Electrical Section

2.2.2 Main Circuit (Video Controller)

Data sent from the host PC is input to the main circuit via an interface or network board. The C269MAIN, the main circuit of the printer, converts data from the PC into raster data to generate video signals. The video signals turn on/off the laser diode on the printhead to form latent images on the PC drum.

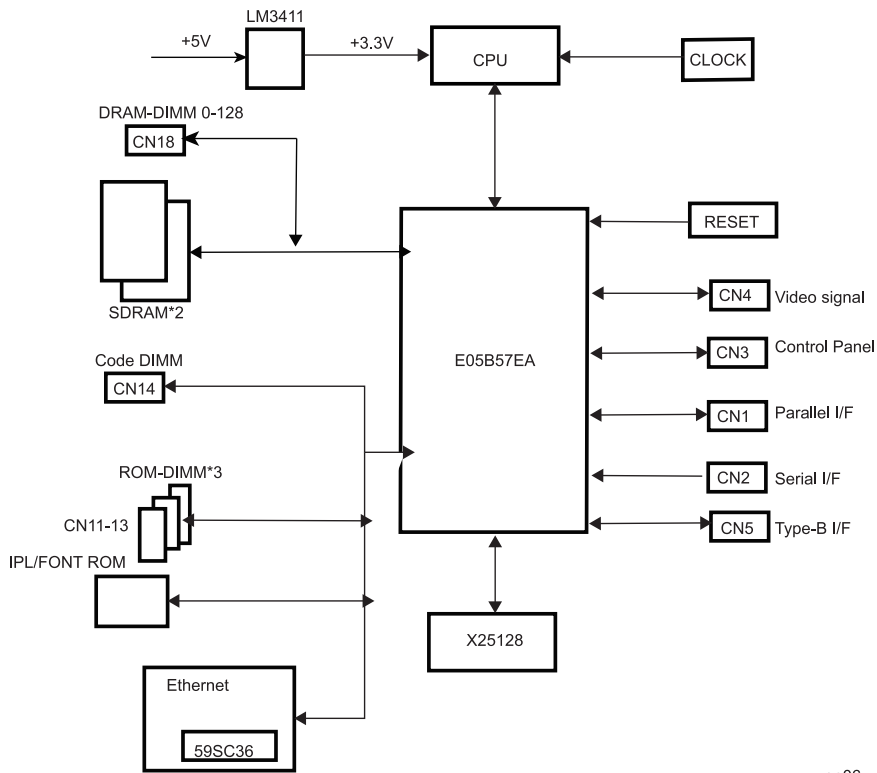

Figure 2-34. Main Circuit Block Diagram

op06

2.2.2.1 Main Component in the Main Circuit Board

The following table lists the main components on the main circuit board.

Table 2-3. Main Components in the Main Circuit Board

Item	Name (Location)	Functions
CPU	VR4310 (IC9)	<ul style="list-style-type: none"> 64-bit CPU (Internal operational frequency: 166.7 MH) Clock wavelength: 66.58912MHz
ASIC	E05B57EA (IC14)	<ul style="list-style-type: none"> Memory DMA control Panel - Host interface PGI - RIT - Engine interface EIC
Memory	C215PROG (CN14)	8Mbit Flash ROM-DIMM <ul style="list-style-type: none"> Code Local language Expansion ROM
	ROM (IC7, 8)	32Mbit <ul style="list-style-type: none"> Font
	SDRAM (IC4, 20)	8MB SDRAM <ul style="list-style-type: none"> Various buffers
	(CN8)	Optional SD-RAM slot (168-pin) <ul style="list-style-type: none"> Expansion SDRAM
	X25128 (IC12)	128Kbit EEPROM (serial type) <ul style="list-style-type: none"> Stores printer settings.
Others	M51953 (IC13)	Reset IC <ul style="list-style-type: none"> Reset sat power on.
	59SC36 (IC405)	Network EEPROM
	LM3411 (IC18)	Regulator IC

CHAPTER

3

TROUBLESHOOTING

3.1 Overview

Since the mechanism of page printer is complicated, it is difficult to isolate the cause of the problem exhibited. This chapter explains how to isolate the cause of the problems as well as remedies based on the abnormal phenomena and error conditions.

3.1.1 Printer Messages

The printer messages fall into the following four types:

- Status message:**
Shows the printer's executing status. Only appears when the printer is free from any error or during initialization.
- Error message:**
Shows the error condition that has occurred.
- Warning message:**
Shows the warning condition.
- Service-call error**
Shows the error which requests service-call.

3.1.1.1 Message List

See the following table which lists the messages indicated by the printer.

Table 3-1. Printer Message

Message	Type
(Displays at power on)	Status
Service Req. efff	Service-call error
ROM check	Status
RAM check	Status
Self Test	Status
Reset All	Status
Reset	Status
Job Cancel	Status
x Error yyy *1	Error
Check Duplex P-Size	Error
Jam x x x x *2	Error
Face-down Full	Error
Multibin 1 Full	Error
Multibin 2 Full	Error
Multibin 3 Full	Error
Multibin 4 Full	Error
Multibin 5 Full	Error
Multibin 6 Full	Error
Multibin 7 Full	Error
Multibin 8 Full	Error
Multibin 9 Full	Error
Multibin 10 Full	Error
Insert Imaging Crtg	Error
Cover A Open	Error
Cover D Open	Error
Cover C1 Open	Error
Cover C2 Open	Error

Table 3-1. Printer Message

Message	Type
Cover C3 Open	Error
Cover E Open	Error
Cover F Open	Error
Cover G Open	Error
Multibin is removed	Error
Manual Feed ssssss tttt	Error
Remove Output Paper	Error
Can't Print Duplex	Error
Paper Out ssssss tttt	Error
Toner Out	Error
Paper Set ssssss tttt	Error
Print Overrun	Error
Mem Overflow	Error
Duplex Mem Overflow	Error
Invalid Option	Error
Invalid PS3	Error
Invalid Aux I/F Card	Error
Invalid ROM A	Error
Invalid ROM B	Error
Writing Error ROM A	Error
Writing Error ROM P	Error
Reset to Save	(Status)
Writing ROM A	Status
Writing ROM P	Status
Memus Locked (panel setting display)	Warning
Collate was disabled	Warning
Check Paper Size	Warning
Image Optimum	Warning
Check Paper Type	Warning
Outbin Select Error	Warning
Need Memory	Warning

Table 3-1. Printer Message

Message	Type
Format Error ROM A	Warning
Format Error ROM B	Warning
Form Feed (Test printing display)	Warning
Warming Up	Status
Toner Low	Warning
Offline	Status
Standby	Status
Ready	Status

*1: x = LCC/Multibin, yyy = 3-digit number

<x> <yyy>

LCC#132:LCC carrier motor error (2-20)

#133:LCC lift motor error (2-21)

#135:LCC lifter 1 limit error (2-23)

#136:LCC lifter 2 limit error (2-24)

#137:LCC communication error (2-25)

Multibin#740:Shift error (2-28) (5-bin mailbin)

#743:Movable guide drive error (2-30)

(5-bin mailbin)

#748:Horizontal carrier drive error (2-30)

(10-bin, Finisher)

#750:Carrier driver error (2-32)

(10-bin, finisher)

*2: Jams may occur in several locations at once, and if that happens, the locations are given in this order of priority:

A, B, C1, C3, D, E, F, G, L, LC2, LC3 (with a maximum of four locations displays). There will be a space between each of the indications of jam locations.

3.1.1.2 Message Descriptions

This section describes the messages specific to EPL-N2700.

x Error yyy (error)

Given when a problem occurs with the paper feeders or output bins.

<Remedy>

Power down temporarily, check the connection on the device where the error has occurred and start-up again.

If the problems is not solved, there is a possibility of malfunction.

Check Duplex P-size (error)

Occurs when duplex printing cannot be done because the paper size that has passed and the paper size selected for duplex printing were deferent.

<Remedy>

Open the cover on the paper feed path and remove the jammed paper, then close the cover.

If the problems is not solved, there is a possibility of malfunction.

Jam xxxx (error)

A paper jam has occurred at the indicated location. If more than one locations are indicated, it means there is a possibility of jammed paper near the indicated locations. Therefore, the numbers of locations and the jammed paper do not match.

<Remedy>

Open the cover indicated, remove the jammed paper, and close the cover.

Face-down Full (error)

The printer attempts to eject paper to the FD, but the FD was full. Only occurs when the multibin or finisher is installed. (Does not occur without any options installed.)

<Remedy>

After removing paper from the FD, press the Continue button, and the printer resumes printing.

Multibin <N> Full (error)

The printer attempts to eject paper to the multibin <N>, but the bin is full.

<Remedy>

After removing paper from the multibin, press the Continue button, and the printer resumes printing.

Cover A - G Open (error)

Cover at the indicated position is open.

<Remedy>

Close the cover indicated.

Multibin is removed

10-bin multibin is not properly installed. The 10-bin multibin was separated from the printer to open the door to remove the jammed paper, and the 10-bin multibin is left separated from the printer.

<Remedy>

Install the 10-bin multibin to the printer main body.

Manual Feed ssss ttt (error)

When the manual feed mode is selected by the panel or command, the selected paper source and paper size are indicated before printing starts.

<Remedy>

Press the Continue button, and printing starts. If paper is loaded in the selected paper source ssss, the printer feeds paper from that paper source. If not, the printer feeds paper from the paper source of the highest priority among the ones which hold paper. In case

none of the paper source has paper in it, the message “Manual Feed ssss ttt” is indicated again. Even though the fed paper size does not match ttt, “Check Paper Size” is not indicated.

Remove Output Paper (error)

When the multibin mode is changed from the previous one, paper remains in the multibin unit.

<Remedy>

Remove all paper in the multibin unit, and the error is automatically cleared.

Can't Print Duplex (error)

Duplex print is not available due to restricted matter on the duplex print.

<Remedy>

Press the Continue button, and the printer starts single printing. If “Auto Cont” in the Config menu is activated, the printer starts single printing after specified period of time. In case the error relates to the paper source device, the printer may start duplex printing when the device's condition changes and the error is cleared.

Invalid option (error)

The option currently installed is not supported by the printer.

<Remedy>

Turn the printer off and remove the corresponding option.

Check Paper Type (warning)

When “Paper Source” is set to “Auto” and paper type is specified, none of the paper sources holds paper whose size and type both meet the selected paper size and type. So the printer loads paper from the paper source which holds the paper that does not match the selected paper type but the size only. In case the paper source set for the paper of the selected paper size and type is empty, “Paper Out” error occurs instead of this warning.

Outbin Select Error

The output device used is other than selected one because the selected device is restricted.

3.1.2 Service-call Error

The service-call errors fall into two categories; engine related and controller related, as described in the next sections.

3.1.2.1 Engine Related Error

The following table lists the engine related errors which can occur in this printer.

Table 3-2. Engine Related Error List

Error Code	Description
E0004	Main motor error
E0005	Fan motor error
E0006	Polygon motor error
E0008	Engine EEPROM error
E0014	Error in communications with engine
E0015	Error in communication with option
E0030	Fuser error (time-out)
E0032	Fuser error (overheat)
E0034	Fuser error (low temperature error)
E0041	IU motor error
E0046	HSYNC detection error
E0047	IU fuse blown error

3.1.2.2 Controller Related Error List

The following table lists the controller related errors which can occur in this printer.

Table 3-3. Controller Related Error List

Error Code ffff	Description	Error Code ffff	Description
0017	CPU error (undefined interrupt occurred)	0258	CPU error (brake generated)
0081	CPU error (TLB revision exception [Load/Fetch])	0800	IPL error (controller defective)
0082	CPU error (TLB error exception [Store])	1220	Standard RAM error (such as when there is no standard-sized segment)
0083	CPU error (TLB miss exception [Store])	1010	Verification error
0084	CPU error (Address error exception [Load/Fetch])	1020	RAM error (slot 0)
0085	CPU error (Address error exception [Store])	1100	ROM checksum error (bits 0-15) (font)
0086	CPU error (Bus error exception [Fetch])	1101	ROM checksum error (bits 16-31) (font)
0087	CPU error (Bus error exception [Load/Store])	1120	ROM checksum error (bits 0-7) (program)
0088	CPU error (SYSCALL exception)	1121	ROM checksum error (bits 81-5) (program)
0089	CPU error (Break exception)	1122	ROM checksum error (bits 16-2) (program)
0090	CPU error (reserve command exception)	1123	ROM checksum error (bits 24-3) (program)
0091	CPU error (co-processor unused exception)	1170	Option FONT ROM checksum error
0092	CPU error (FPU exception)	1180	Option ROM module A checksum error
0093	CPU error (TLB exception)	1181	Option ROM module B checksum error
0094	CPU error (XTLB exception)	1185	Unsupported ROM module
0095	CPU error (cache exception)	1190	Cartridge not access
0096	CPU error (Trap exception)	1200	EEPROM write error
0097	CPU error (FPU exception)	1210	EEPROM write times limit
0098	CPU error (watch exception)	1400	Engine initialization error
0128 - 0254	CPU error (undefined trap)	1700	Built-in network hardware error
0255	CPU error (NMI exception)	1999	Other hardware error
0256	CPU error (multiplied by 0)	2000	Software error
0257	CPU error (arithmetic/logic operation overflow)	-	-

3.1.2.3 Clearing the Service-call Error

Service-call error can be cleared by taking appropriate actions as shown in Chapter 1 / Section 1.4.4 “Special Functions”.

3.1.3 Adding on RAM

The EPL-N2700 may display such messages as Duplex Mem Overflow, Mem Overflow, Image Optimum, Collate was disabled, and Need Memory. If any of these messages displays, use the following remedies.

- 1) Make the resolution 300 dpi.
- 2) Set the receive buffer size on minimum.
- 3) Fix the interface.

To avoid any shortage of memory, memory must be increased. (Limited to SDRAM DIMMs for PCs that are available on the marked: 168-pin, with SPD)

3.1.4 Troubleshooting

Troubleshooting for the engine related problems are described in the following sections.

3.1.4.1 The Printer will not Start

Table 3-4. Troubleshooting - The Printer will not Start.

Symptom	Analysis	Finding	Action
The printer won't start.	Plug in another electrical appliance and see if it is started.	No	Faulty power outlet.
		Yes	To next step.
	Check the power cord for continuity.	No	Defective power cord.
		Yes	To next step.
	Listen for the fan starting whirling.	No	Defective low voltage power supply unit.
		Yes	Defective or loose control panel.

3.1.4.2 The Printer will no Print.

Table 3-5. Troubleshooting - The Printer will not Print.

Symptom	Analysis	Finding	Action
The printer does not eject paper.	Is the On Line LED ON?	No	Press the On Line button to turn ON the On Line LED.
	You get a message other than "Ready."	Yes	Follow the message.
	Does the printer give a correct test print?	Yes	Check the connection between the printer and computer.
The printer ejects blank sheets of paper.	The printer does print, but ejects blank sheets of paper.	Yes	Refer to Image Quality Problems.

3.1.4.3 Image Quality Problems

Table 3-6. Troubleshooting - Image Quality Problem

Symptom	Analysis	Finding	Action
Faulty image	Does the symptom still occur in a test print?	No	Check the connection between the printer and computer. If it is proper, the application or printer driver is probably faulty.
The printer ejects blank sheets of paper.	Turn OFF the printer during a print cycle and check to see if toner sticks to the PC Drum.	Yes	Defective image transfer bias. Replace High Voltage Unit.
	Replace the Imaging Cartridge to determine if the problem persists.	No	Replace ROS unit.
Solid black	Replace the Imaging Cartridge to determine if the problem persists.	No	Replace High Voltage Unit.
Lines (feeding direction)	Is the PC Drum scratched?	Yes	Replace the Imaging Cartridge.
		No	Replace ROS unit.
Lines (direction perpendicular to feeding direction)	Pitch is 94.2 mm.	Yes	Replace the Imaging Cartridge. (Clean the PC Drum.)
	Pitch is 56.5 mm.	Yes	Clean/replace the Timing Roller or Image Transfer Roller.
	Pitch is 93.5 mm.	Yes	Replace the Fusing Unit. (Clean/replace the Fusing Rollers.)
	Pitch is 33.9 mm.	Yes	Clean/replace the Exit Roller.

CHAPTER

4

DISASSEMBLY/ASSEMBLY

4.1 Overview

4.1.1 Precaution

Observe the following instruction well before starting servicing.



- Before servicing, turn the printer power off and unplug the power cord from the AC socket.
- Before removing the fuser and nearby parts, turn the printer off and wait for at least 30 minutes to lower the fuser temperature.
- Since the printer weighs 30 Kg, be sure to carry the printer with 2 people.



Before starting servicing, make sure the following points:

- Interface cable is disconnected from the back of the printer.
- No option is installed on the printer.
- Wear the wrist strap to release static electricity so you can avoid damaging static electricity sensitive components.

4.1.2 Tools

The tools used to disassemble/assemble this printer are as listed below:

Table 4-1. Tool List







Name	Availability	Code
Phillips screw driver	A*1	B743800100
Phillips screw driver	A	B743800500
Standard driver	A	B743000100
Tweezers	A	B641000100
Pillars	A	B740400100







*1:A = Available on the market







4.1.3 Small Parts

The small parts used in the printer are listed in the following table.

Table 4-2. Small Part Classification

Reference No.	Size	Name	Appearance
0208	3 × 10	Spring pin	 0208
0214	3 × 20		
0242	3 × 18		
0245	3 × 18		
0509	2 × 12	Pin	 0510
0510	3 × 14		
0512	2 × 18		
0531	3 × 18		
0534	1.5 × 6		
0535	2.5 × 10		
1210	3 × 8	CP with a spring washer screw	 1208
1305	3 × 6	Screw with a spring washer + plane washer	 1305
1308	3 × 8		
1309	3 × 10		
1322	4 × 14		
1379	2 × 4		
1421	3 × 8	Flat head screw	 1421
1723	3 × 8	Cup screw	 1723

Reference No.	Size	Name	Appearance
2101	3 × 6	Bind screw	 2703
2703	4 × 6		
3104	3 × 8	Tapping screw (Pan head B-tite screw)	 3104
3114	4 × 6		
3211	3 × 14	Tapping screw (Flat head B-tite screw)	 3211
3305	3 × 8	Tapping screw (Pan head B-tite screw)	 3305
3402	3 × 6	Tapping screw (Pan head S-tite screw)	 3402
3435	3 × 30		
3501	3 × 6	Tapping screw (Cup head S-tite screw)	 3501
3504	3 × 8		
3505	3 × 10		
3506	4 × 6		
3509	4 × 10		
3520	3 × 14		
3541	3 × 8		
3702	4 × 10		
3703	4 × 12		
3704	3 × 8		
3708	3 × 8		
3709	3 × 10		
3727	3 × 8		

Reference No.	Size	Name	Appearance
3907 3923	3 × 8 3 × 10	Tapping screw (Binding head B-tite screw)	 3907
4011	3 × 8	Tapping screw (Binding head S-tite screw)	 4011
4012	3 × 6		
4021	3 × 8		
4025	3 × 6		
7107	4 × 6	Setscrew	 7107
8501		Plane washer	 8501
9102 9103 9105 9107 9111 9112 9140 9151	#2 #2 #3 #4 #5 #6 #5 #7	E-ring	 9102
9301 9302 9303		Retaining ring	 9301

4.2 Disassembly Procedure

This section contains the disassembly procedure for EPL-N2700. The flowchart for the disassembly procedure is as shown below. For the information on the parts which are not included in this Chapter, refer to Chapter 7 / Exploded Diagrams.

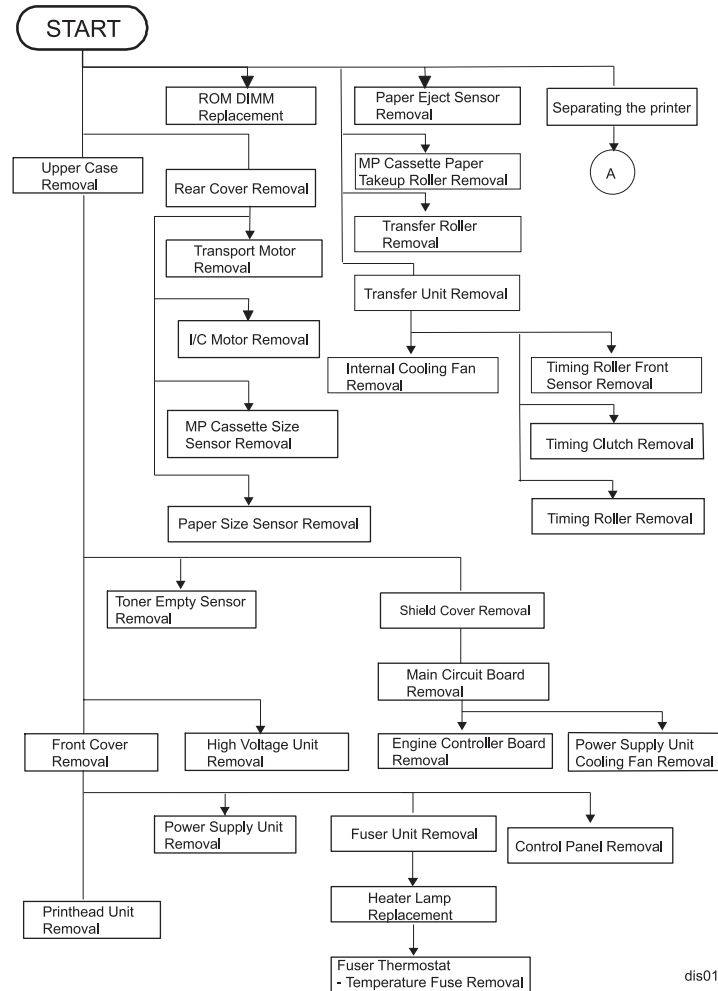

Figure 4-1. Disassembly Flowchart (1)

dis01

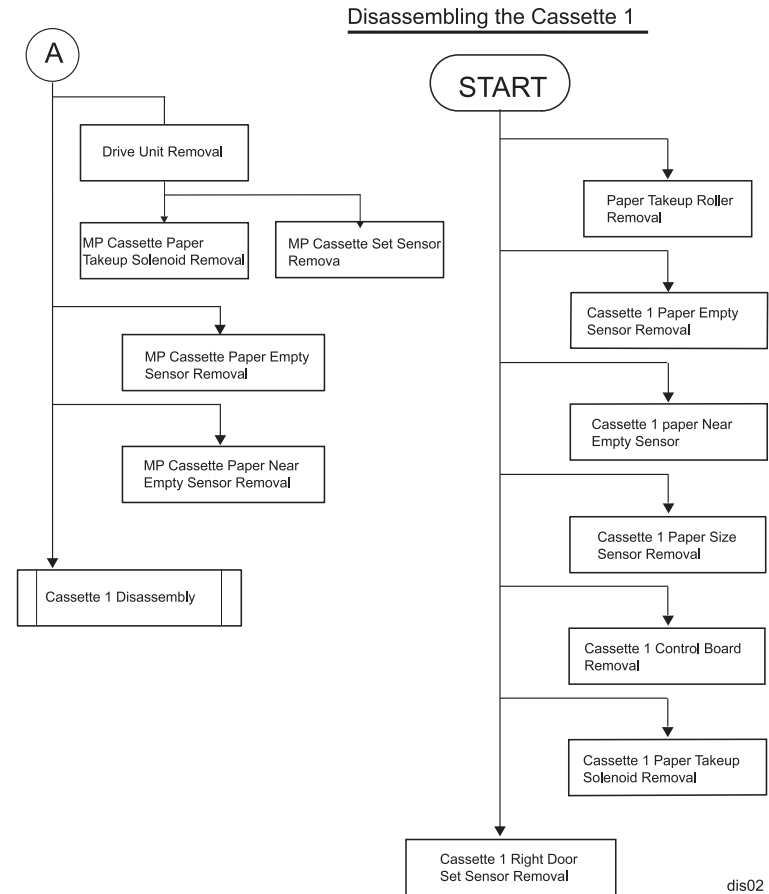

Figure 4-2. Disassembly Flowchart (2)

dis02

4.2.1 ROM DIMM Removal

1. Release two hooks fixing the access cover to the Upper Case and remove the access cover.
2. Remove two screws (1305) securing the upper shield cover and remove the upper shield cover.
3. Remove ROM DIMM from the PROG DIMM socket.

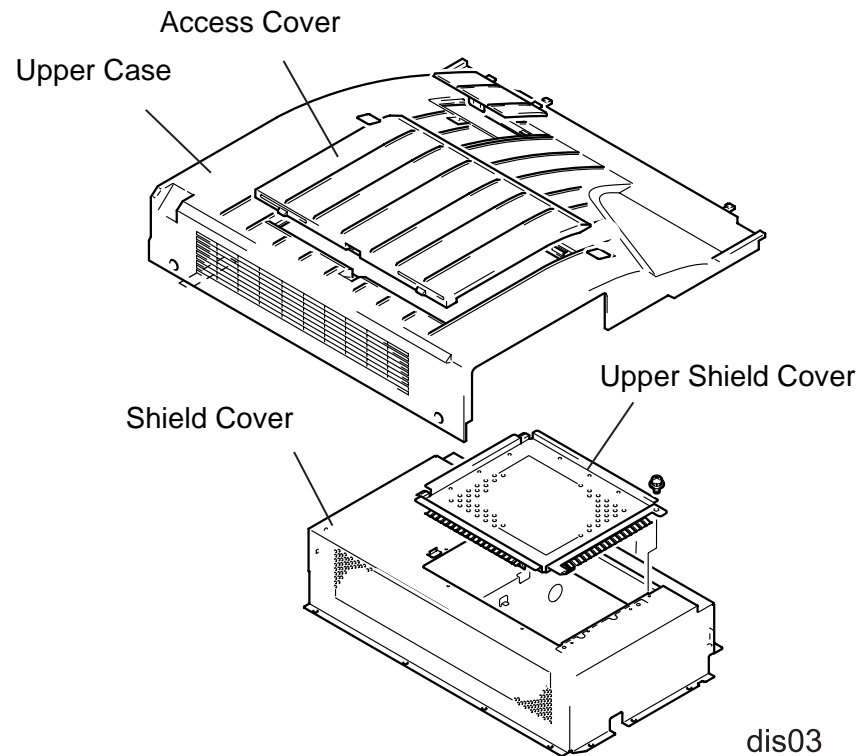

Figure 4-3. ROM DIMM Replacement

4.2.2 Paper Eject Sensor Removal

1. Open the Fuser Unit Cover and release two hooks securing the Paper Eject Sensor Cover to the Fuser Unit and remove the cover.

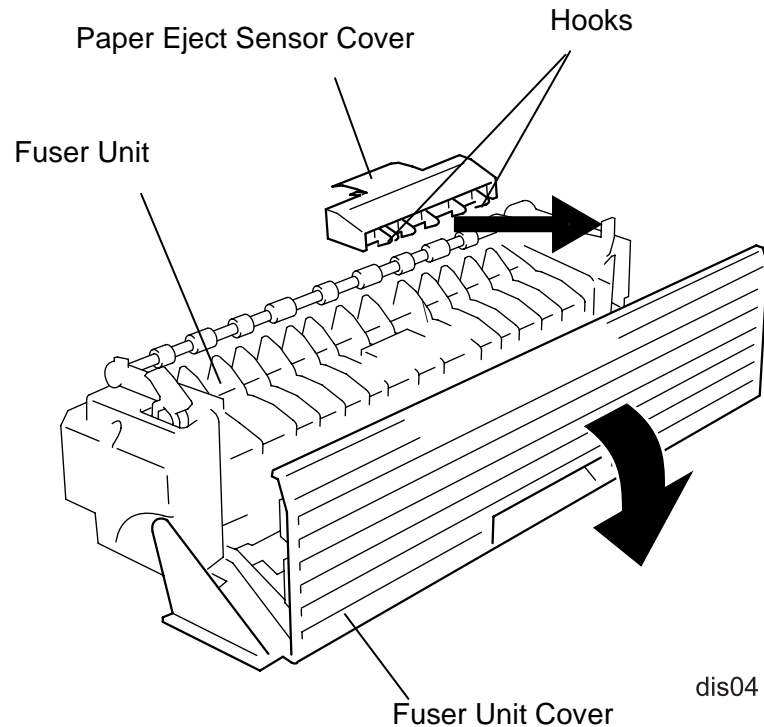

Figure 4-4. Paper Eject Sensor Cover Removal

2. Remove the sensor stopper from the Fuser Unit.
3. Disconnect the sensor harness from the sensor connector.
4. Remove the actuator and remove the Paper Eject Sensor.

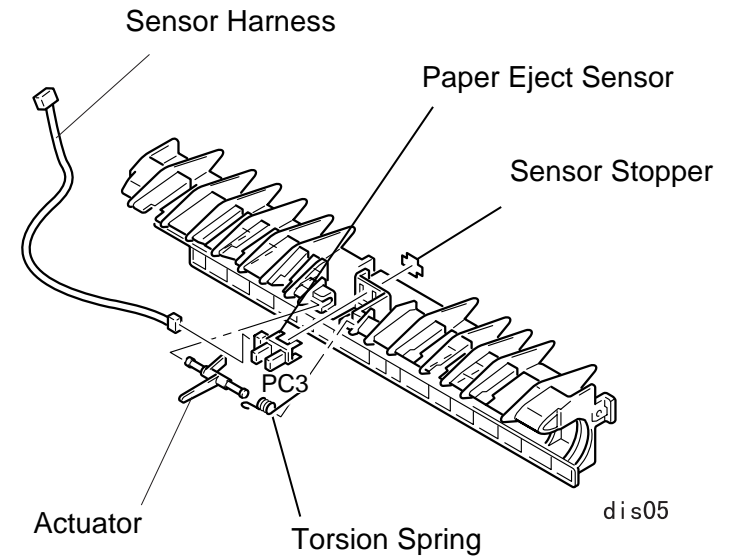

Figure 4-5. Paper Eject Sensor Removal

4.2.3 MP Cassette Paper Take-up Roller Removal

1. Take out the MP Cassette from the printer body.

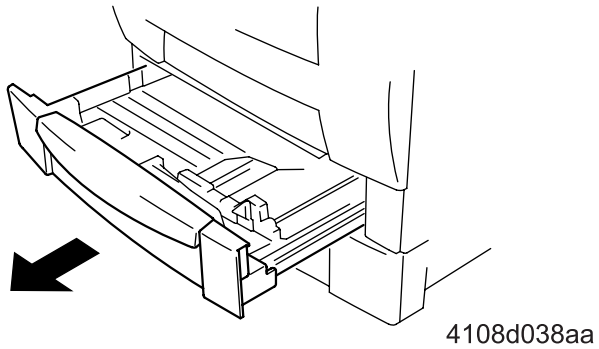

Figure 4-6. Taking out the MP Cassette

2. Remove the C-clip from the Paper Take-up Roller.
3. Slide the Paper Take-up Roller Assembly to the rear and remove the Paper Take-up Roller Assembly from the bushing (front).

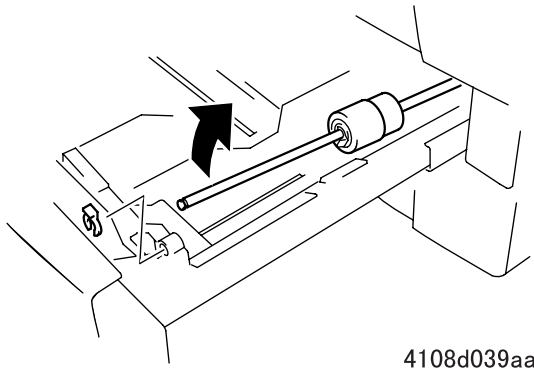

Figure 4-7. Paper Take-up Roller Assembly Removal

4. Remove the C-clip and remove the Paper Take-up Roller.

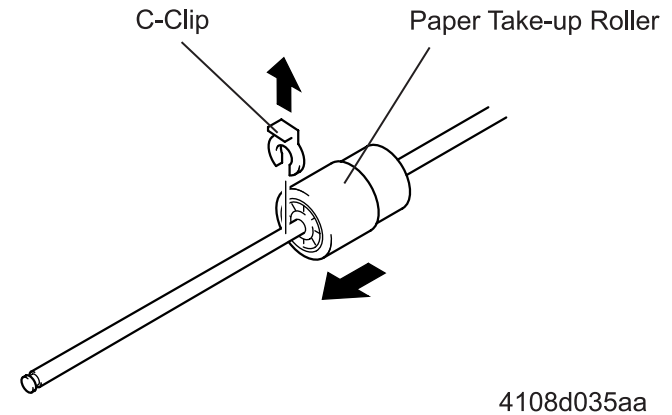

Figure 4-8. MP Cassette Paper Take-up Roller Removal

4.2.4 Transfer Section

4.2.4.1 Transfer Roller Removal

1. Open the vertical transport door.

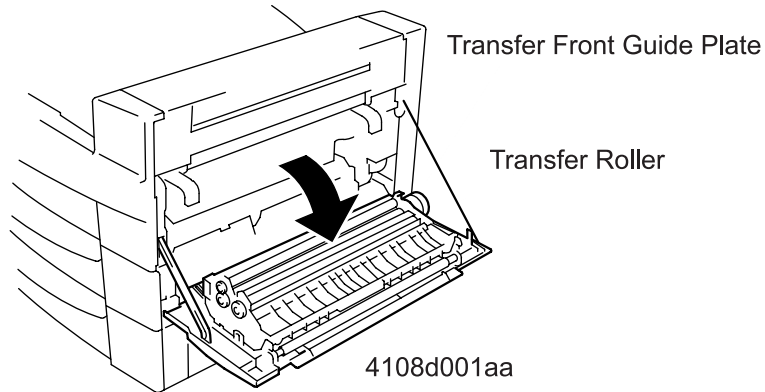

Figure 4-9. Opening the Vertical Transport Door

2. Put up the transfer front guide plate.
3. Remove the Transfer Roller.

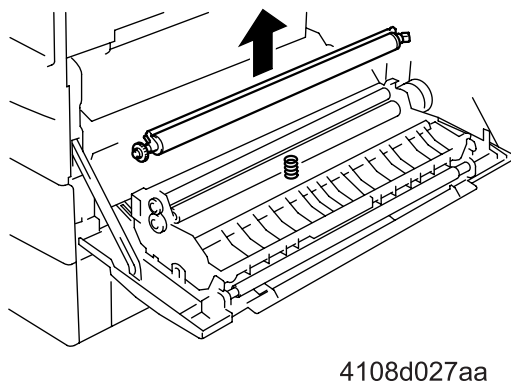

Figure 4-10. Transfer Roller Unit Removal



- Never touch the transfer roller surface with your bare hands. Doing so may affect print quality.
- If you have replaced the Transfer Roller Unit, be sure to perform “TR Counter Clear” in the maintenance mode. (See Chapter 1 / Section 1.4.5.)

4.2.4.2 Transfer Unit Removal

1. Release two hooks securing the Transfer Unit to the vertical transport door and lift the Transfer Unit a little.
2. Disconnect the harnesses for the Timing Clutch and Timing Roller Front Sensor from the corresponding connectors. Then remove the Transfer Roller Unit from the vertical transport door.

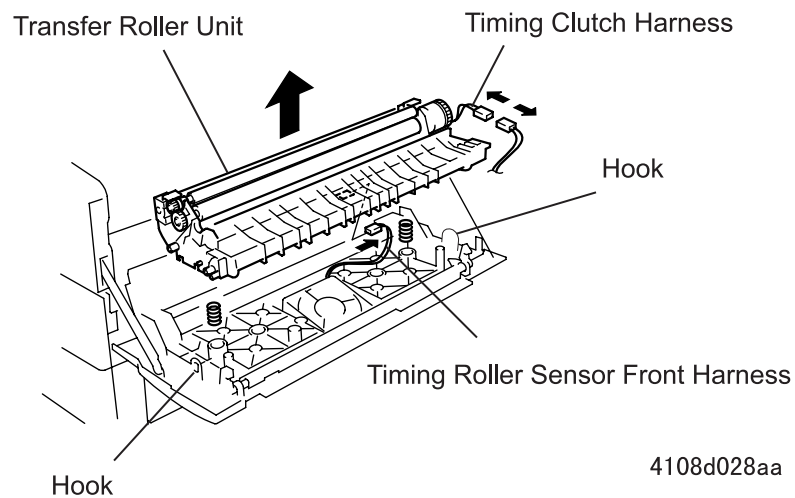

Figure 4-11. Transfer Unit Removal



Since the harnesses are short, disconnect the harness holding up the Transfer Unit, and then remove the Transfer Unit.

4.2.4.3 Timing Roller Front Sensor Removal

1. Remove the Transfer Unit. (See Section 4.2.4.2.)
2. From the back of the Transfer Unit, release the hooks securing the Timing Roller Front Sensor to the sensor bracket, then remove the Timing Roller Front Sensor.

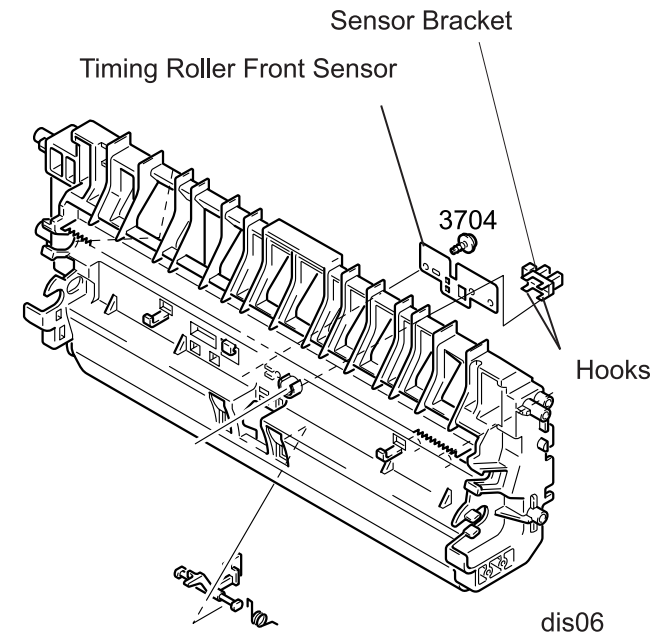

Figure 4-12. Timing Roller Front Sensor Removal

4.2.4.4 Timing Clutch Removal

1. Remove the Transfer Unit. (See Section 4.2.4.2.)
2. Remove the E-ring (9140) fixing the Timing Clutch to the Transport Roller (Timing Drive Roller) and remove the Timing Clutch from the Holder Assembly.



When installing the Timing Clutch, be sure to align the fork on the clutch with the mounting point on the Holder Assembly.

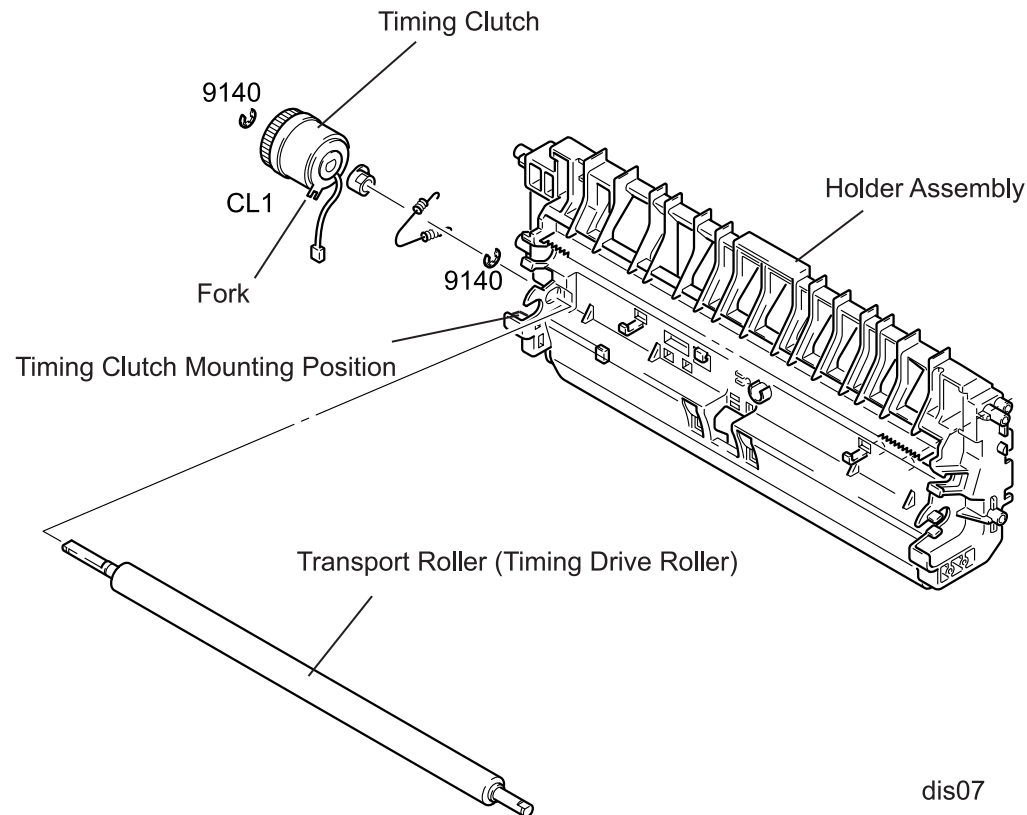

dis07

Figure 4-13. Timing Clutch Removal

4.2.4.5 Timing Roller Removal

1. Remove the Transfer Unit. (See Section 4.2.4.2.)
2. Put up the transfer front guide plate. (See Section 4.2.4.1.)
3. Remove the Timing Clutch. (See Section 4.2.4.4.)
4. Release the hook securing the Guide Bar to the Holder Assembly and remove the paper dust remove filter from the Holder Assembly.
5. Remove two tension springs securing the bushing for the Timing Driven Roller to the Holder Assembly.
6. Remove two E-rings (9140) from the right and left ends of the Timing Sub Roller. Then remove one gear (13T), two bushings, and the Timing Driven Roller.
7. Remove E-rings (9140) from the right and left ends of the Timing Drive Roller. Then remove one gear (18T), two bushings, and the Timing Drive Roller.

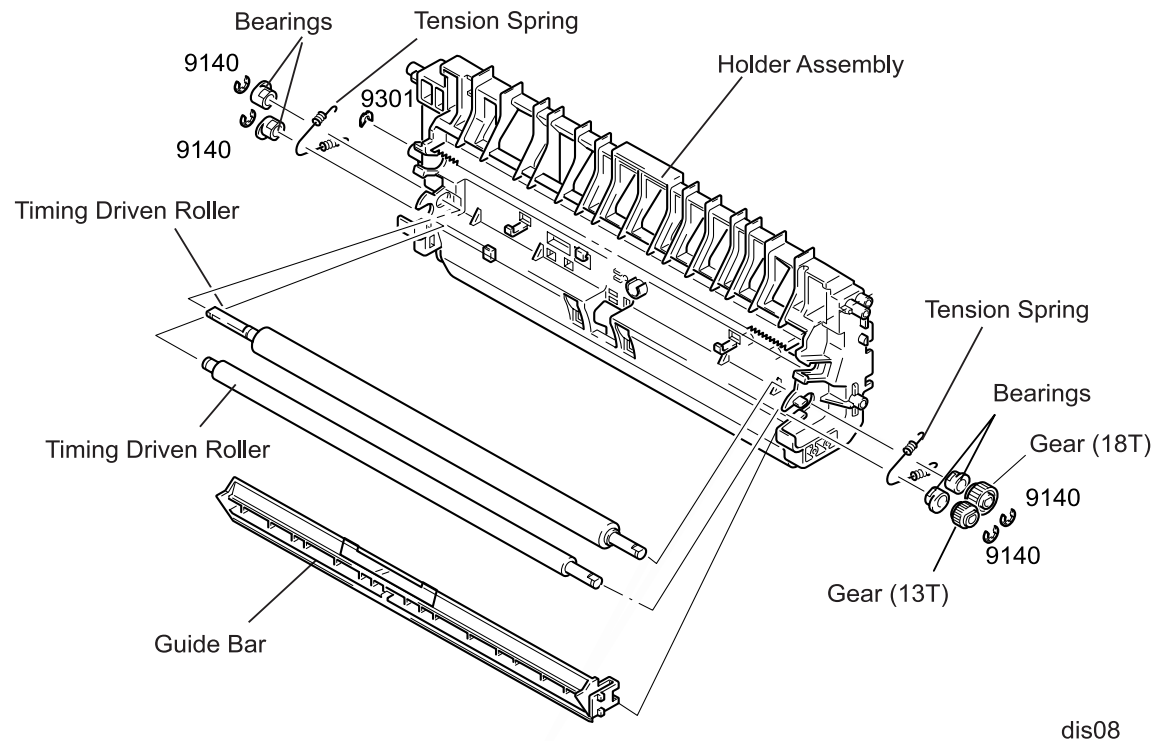

Figure 4-14. Timing Roller Removal

4.2.4.6 Internal Cooling Fan Removal

1. Remove the Transfer Unit. (See Section 4.2.4.2.)
2. Disconnect the motor harness from the connector.
3. Remove two screws (3704) securing the Internal Cooling Fan to the vertical transport door, and remove the Internal Cooling Fan.

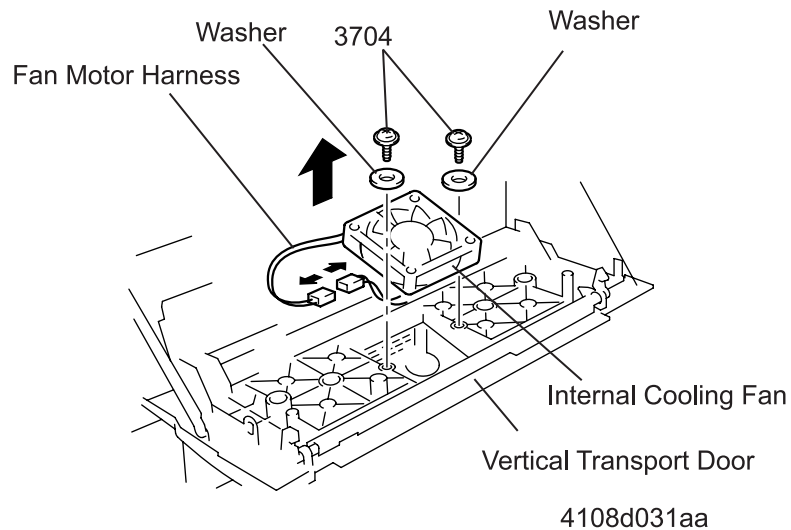

Figure 4-15. Internal Cooling Fan Removal



Be sure to install the fan with its ventilation side facing outward.

4.2.5 Separating the Printer

1. Remove 1 screw (3727) securing the frame to the back of the Cassette 1, and remove the frame.
2. Disconnect the harness linking the printer and the Cassette 1 control board from the connector (PJ1).
3. Remove four screws securing four holders which hold the MP Cassette in the printer and the Cassette 1, and remove the holders.
4. Separate the Cassette 1 from the MP Cassette.

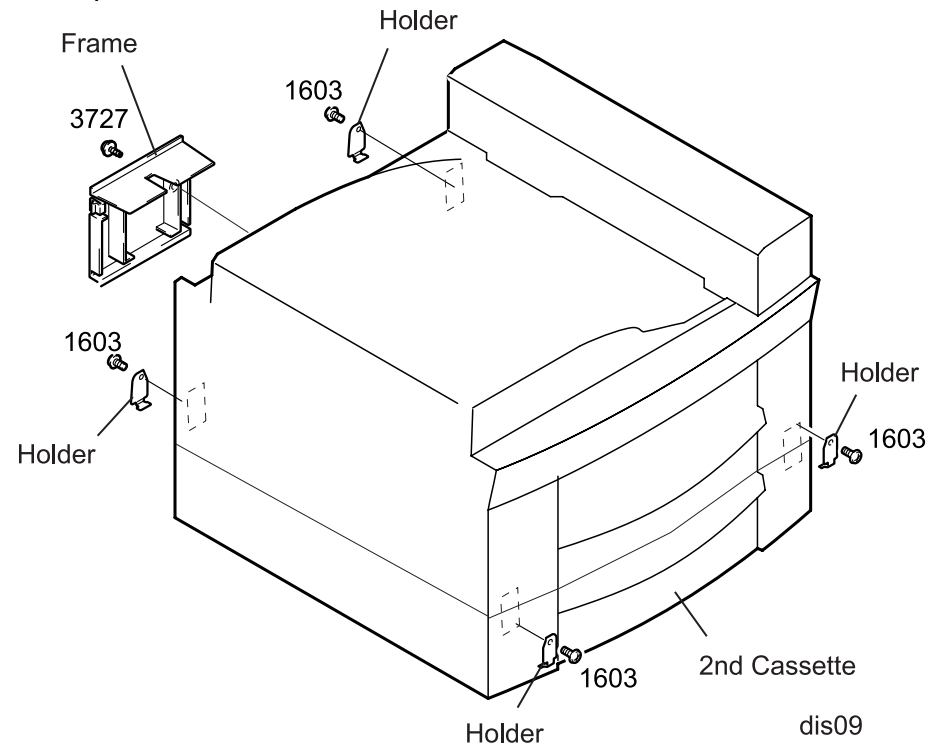

Figure 4-16. Holder Removal

4.2.6 Rear Cover Removal

1. Remove one screw (3541) securing the CN cover to the printer and remove the CN cover.
2. Remove the Harness Cover.
3. Remove the rear optional cover.
4. Remove three screws (3541) securing the rear cover to the printer.
5. Release the hook securing the Rear Cover to the Paper Eject Cover and remove the Rear Cover.

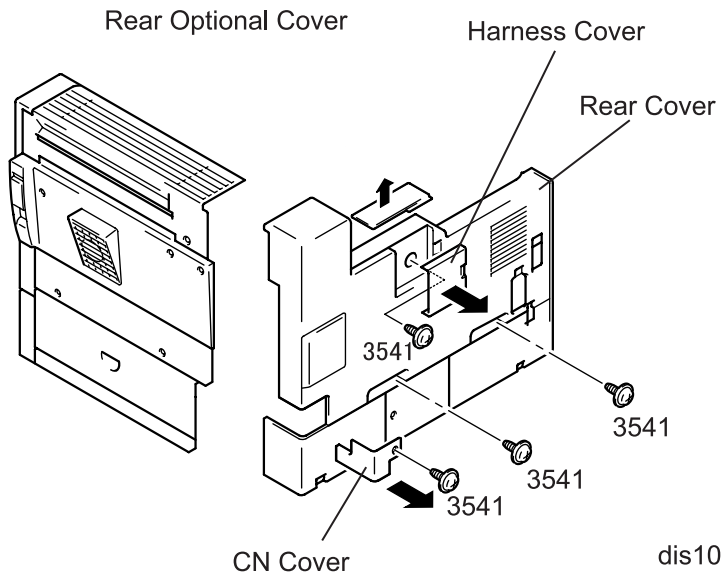

Figure 4-17. Rear Cover Removal

4.2.7 Transport Motor Removal

1. Remove the Rear Cover. (See Section 4.2.6.)
2. Remove four screws (3501) securing the Transport Motor to the printer frame and remove the Transport Motor.
3. Disconnect the harness for the Transport Motor from the connector.

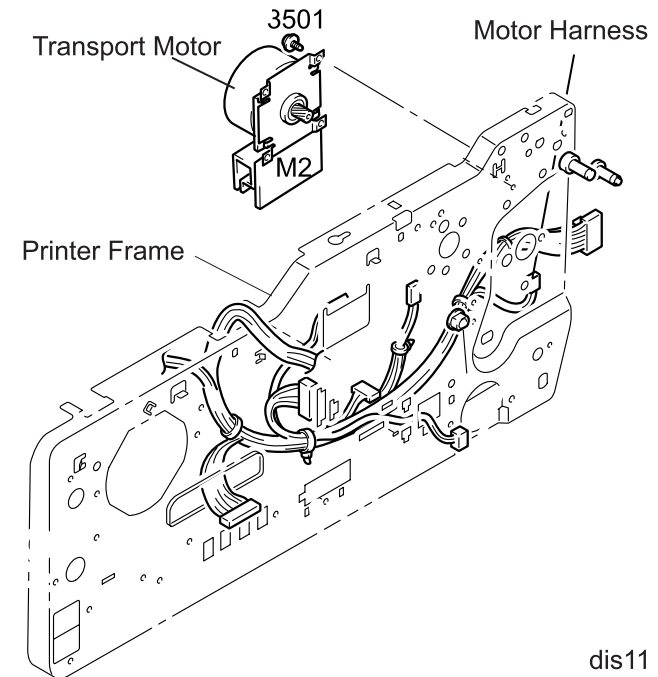

Figure 4-18. Transport Motor Removal

4.2.8 I/C Drive Motor Removal

1. Remove the Rear Cover. (See Section 4.2.6.)
2. Remove four screws (3501) securing the I/C Drive Motor to the printer frame and remove the I/C Drive Motor.
3. Disconnect the harness for the I/C Drive Motor from the connector.

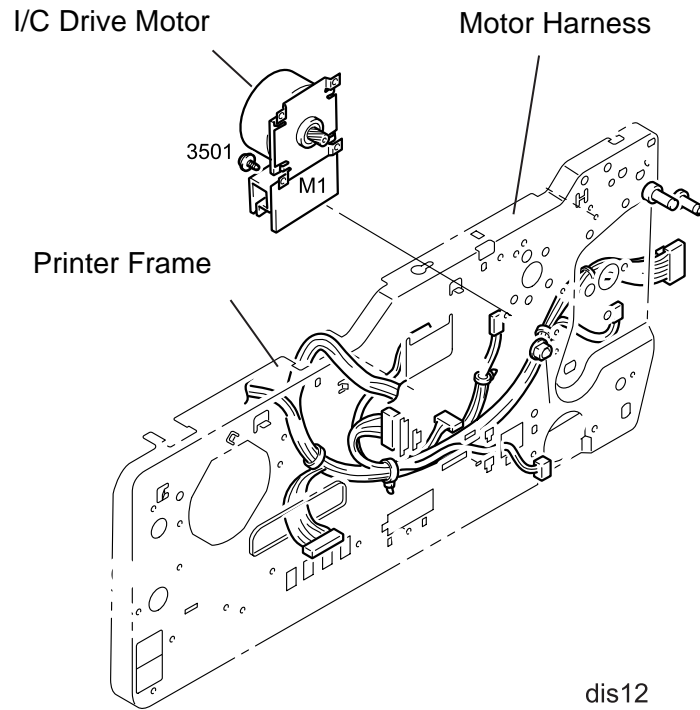

Figure 4-19. I/C Drive Motor Removal

4.2.9 MP Cassette Size Sensor Removal

1. Remove the Rear Cover. (See Section 4.2.6.)
2. Remove the MP Cassette.
3. Remove two screws (3501) securing the cassette size sensor holder to the printer frame, and remove the holder along with the sensor and lever.
4. Disconnect the harness from the connector on the sensor board (PWB-I).
5. Remove the lever from the holder.
6. Remove the sensor board (PWB-I) from the holder.

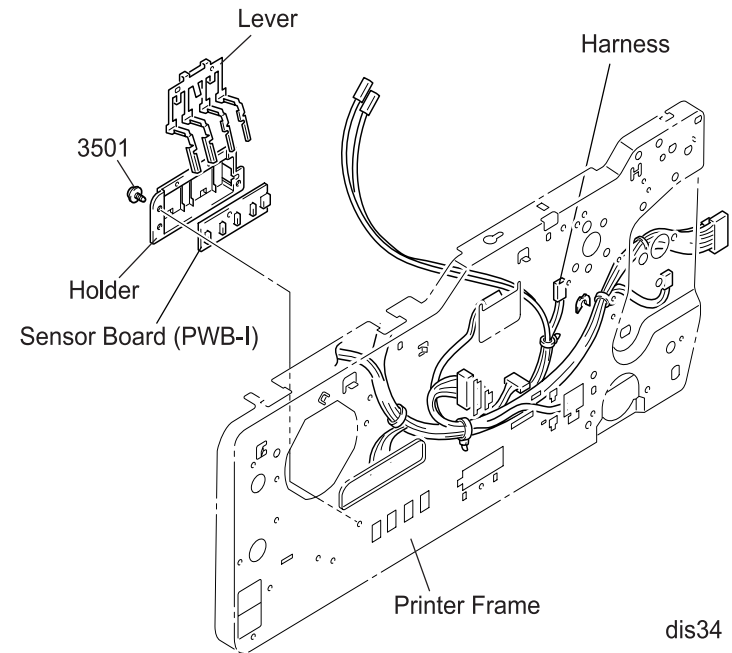

Figure 4-20. MP Cassette Size Sensor Removal

4.2.10 Paper Size Sensor Removal

1. Remove the Rear Cover. (See Section 4.2.6.)
2. Remove the MP Cassette.
3. Remove one screw (3501) securing the paper size sensor bracket to the printer frame, and remove the plate along with the sensor.
4. Release the hook fixing the sensor to the holder and remove the sensor.
5. Disconnect the harness from the connector on the sensor.

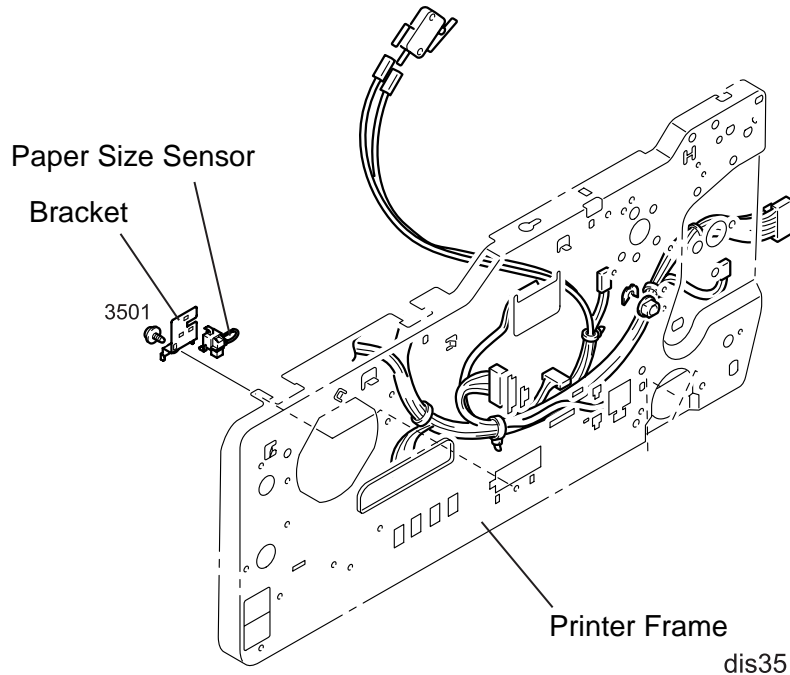

Figure 4-21. Paper Size Sensor Removal

4.2.11 Top Cover Removal

1. Remove two screws (3541) securing the Top Cover to the printer through the left cover.
2. Lift up the left edge of the Top Cover and remove the Top Cover.

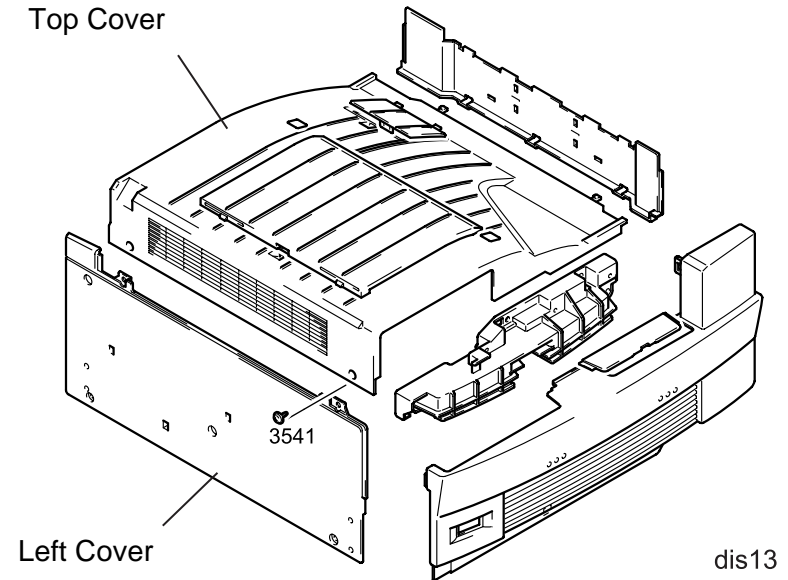

Figure 4-22. Top Cover Removal

4.2.12 Toner Empty Sensor Removal

1. Remove the Top Cover. (See Section 4.2.11.)
2. Remove one screw (3504) securing the Toner Empty Sensor to the printer frame and remove the sensor.
3. Disconnect the harness from the connector on the sensor.

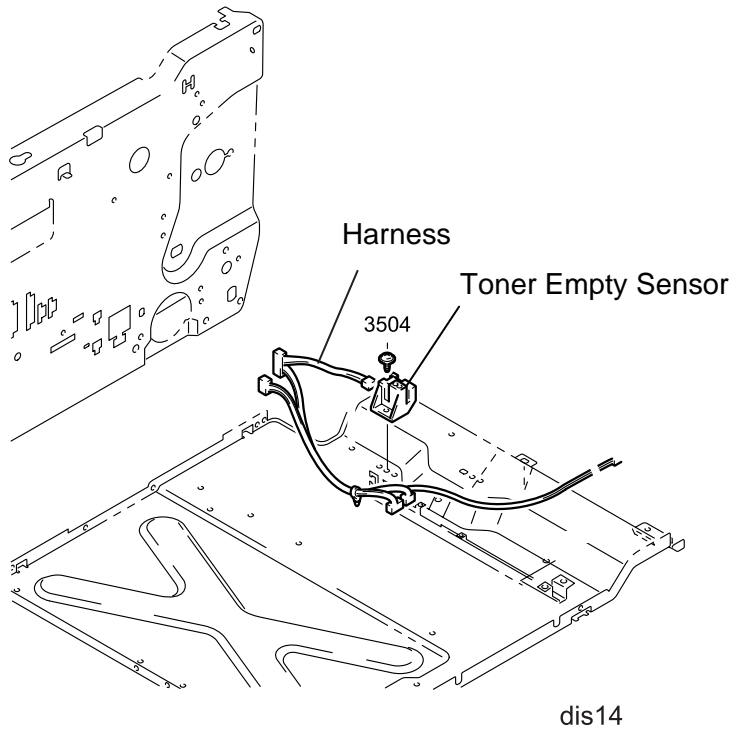
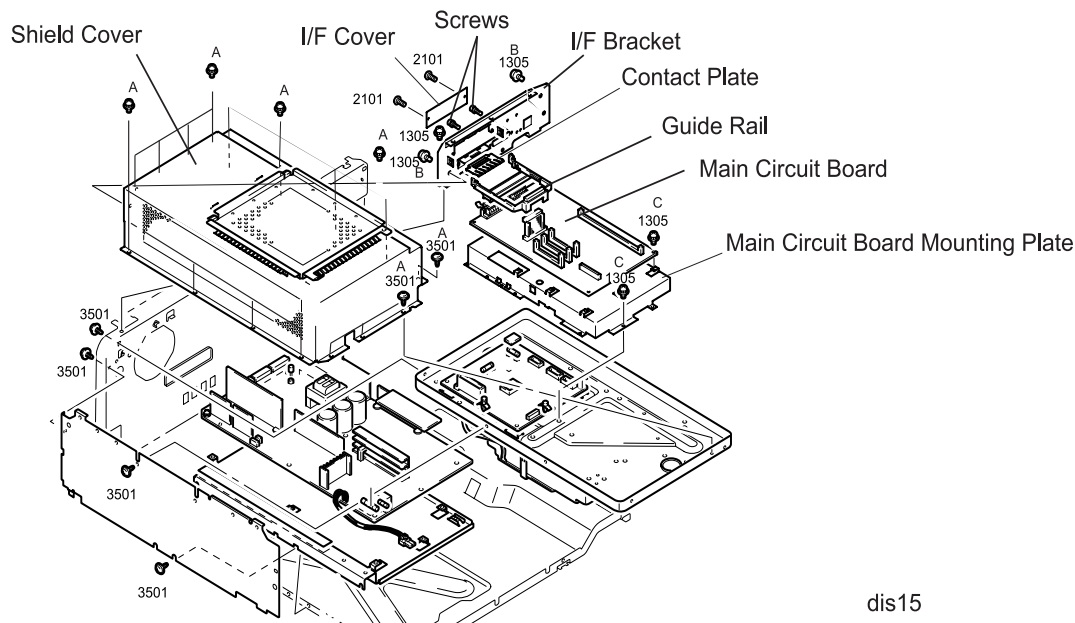

Figure 4-23. Toner Empty Sensor Removal

4.2.13 Main Circuit Board Removal

1. Remove the Rear Cover. (See Section 4.2.6.)
2. Remove the Top Cover. (See Section 4.2.11.)
3. Remove the following screws and remove the Shield Cover.
 - Sixteen screws (3501: marked with A in the figure) securing the Shield Cover to the printer frame.
 - Three screws (1305: marked with B in the figure) securing the Shield Cover to the Interface bracket.
4. Remove twelve screws (1305: marked with C in the figure) securing the Main Circuit Board to the Main Circuit Board Mounting Plate.
5. Disconnect the control panel harness connecting to the Main Circuit Board from the CN3.
6. Remove seven screws (1305) securing the Interface bracket to the printer frame, and remove the Interface bracket along with the Main Circuit Board by moving it upward.
7. Remove the Contact Plate from the Interface bracket.
8. Remove two screws (2101) securing the Interface Cover to the Interface bracket, and remove the Main Circuit Board and Guide Rail.
9. Remove the following screws:
 - Two screws (1305) securing the parallel interface connector to the Interface bracket
 - Two machine screws securing the serial interface connector to the Interface bracket.



dis15

Figure 4-24. Main Circuit Board Removal

4.2.14 Engine Controller Board Removal

1. Remove the Rear Cover. (See Section 4.2.6.)
2. Remove the Top Cover. (See Section 4.2.11.)
3. Remove the following screws and remove the Shield Cover.
 - Sixteen screws (3501: marked with A in the figure) securing the Shield Cover to the printer frame.
 - Three screws (1305: marked with B in the figure) securing the Shield Cover to the Interface bracket.
4. Remove twelve screws (1305: marked with C in the figure) securing the Main Circuit Board to the Main Circuit Board Mounting Plate.
5. Disconnect the control panel harness connecting to the Main Circuit Board from the CN3.
6. Remove seven screws (1305) securing the Interface bracket to the printer frame, and remove the Interface bracket along with the Main Circuit Board by moving it upward.
7. Remove one screw securing the shield cable for the control panel harness to the Main Circuit Board Mounting Plate, and remove the shield cable.
8. Remove twelve screws (1305) securing the Main Circuit Board Mounting Plate to the P/H Plate.
9. Disconnect harnesses from the Engine Controller Board.

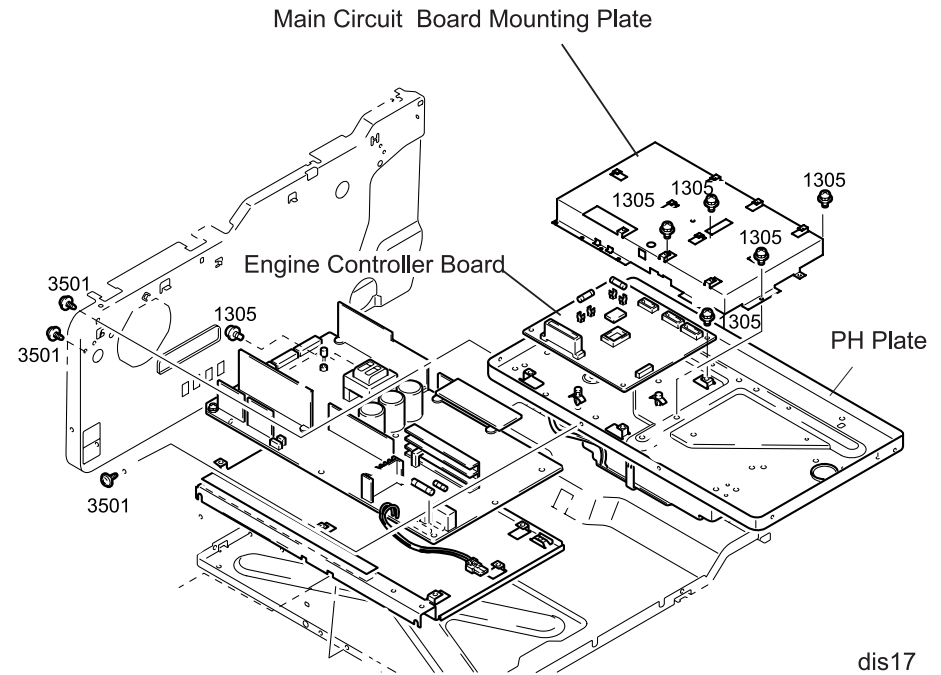

Figure 4-25. Engine Controller Board Removal

dis17

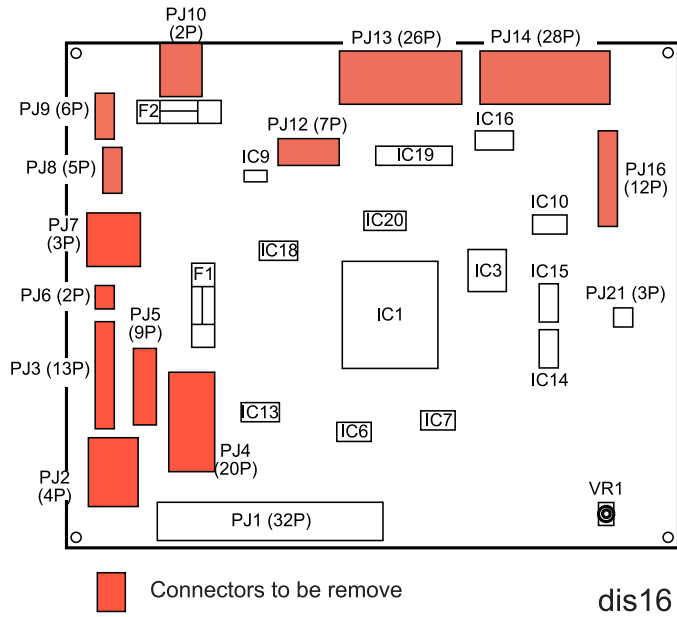

Figure 4-26. Connector Layout

- Remove four screws (1305) securing the Engine Controller Board to the P/H plate and remove the Engine Controller Board.

4.2.15 Power Supply Unit Cooling Fan Removal

1. Remove the Rear Cover. (See Section 4.2.6.)
2. Remove the Top Cover. (See Section 4.2.11.)
3. Remove the following screws and remove the Shield Cover.
 - Sixteen screws (3501: marked with A in the figure) securing the Shield Cover to the printer frame.
 - Three screws (1305: marked with B in the figure) securing the Shield Cover to the Interface bracket.
4. Remove twelve screws (1305: marked with C in the figure) securing the Main Circuit Board to the Main Circuit Board Mounting Plate.
5. Disconnect the control panel harness connecting to the Main Circuit Board from the CN3.
6. Remove seven screws (1305) securing the Interface bracket to the printer frame, and remove the Interface bracket along with the Main Circuit Board by moving it upward.
7. Remove one screw securing the shield cable for the control panel harness to the Main Circuit Board Mounting Plate, and remove the shield cable.
8. Remove twelve screws (1305) securing the Main Circuit Board Mounting Plate to the P/H Plate.
9. Disconnect the power supply unit harness from the connector P/J6 on the Engine Controller Board.
10. Remove two screws (3435) securing the Power Supply Unit Cooling Fan to the printer frame, and remove the Power Supply Unit Cooling Fan.

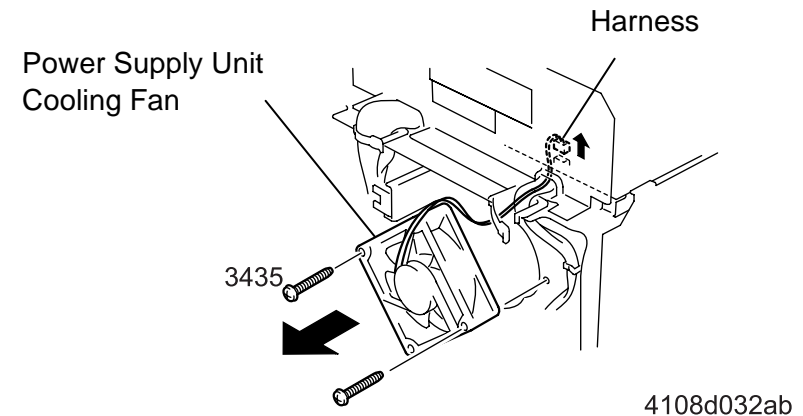

Figure 4-27. Power Supply Unit Cooling Fan Removal



Be sure to install the Power Supply Unit Cooling Fan with its exhausting side facing outside.

4.2.16 High Voltage Unit Removal

1. Remove the Top Cover. (See Section 4.2.11.)
2. Open the vertical transport door.
3. Remove two screws (3504) securing the High Voltage Unit Cover to the printer frame, and remove the cover.
4. Disconnect harnesses from the connector on the High Voltage Unit.

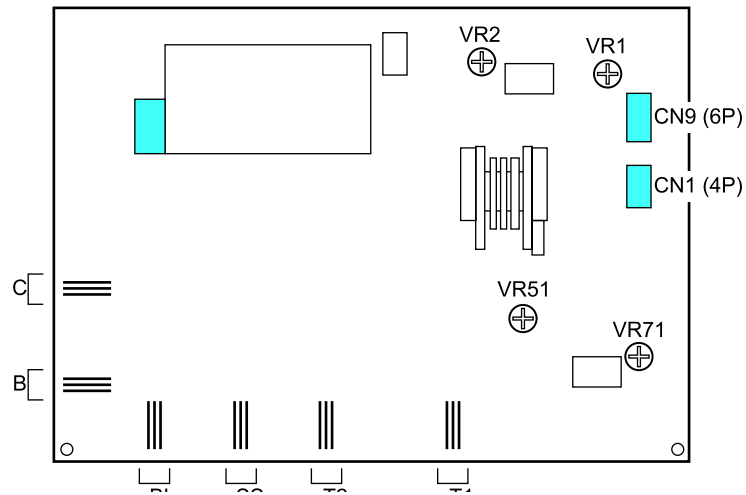

Figure 4-28. Harness Removal

5. Remove two screws (3501) securing the High Voltage Unit to the printer frame.

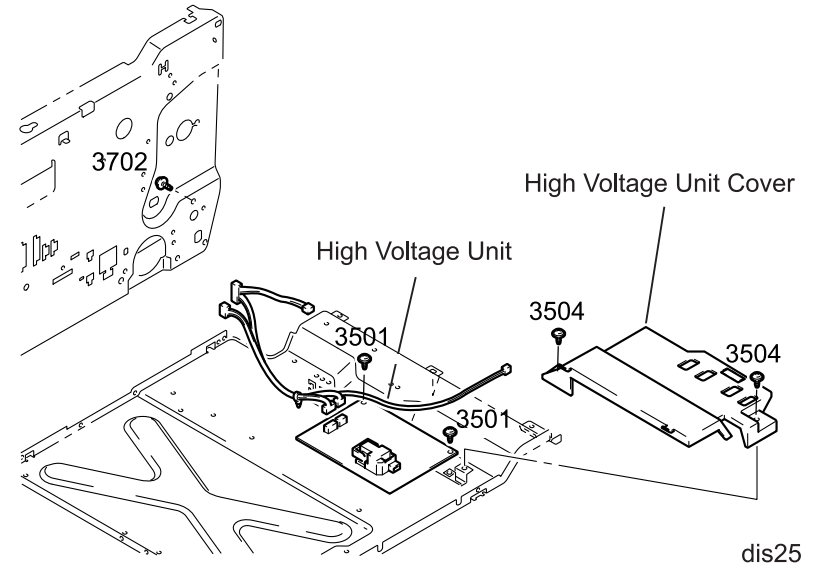

Figure 4-29. High Voltage Unit Removal

4.2.17 Front Cover Removal

1. Remove the Top Cover. (See Section 4.2.11.)
2. Take out the MP Cassette.
3. Open the vertical transport door and remove one screw (3501) securing the Front Cover to the printer frame.
4. Remove two screws securing the Front Cover to the printer frame.
5. Release the hook securing the Front Cover to the Paper Eject Cover.
6. Remove the Front Cover by opening it from the right side.

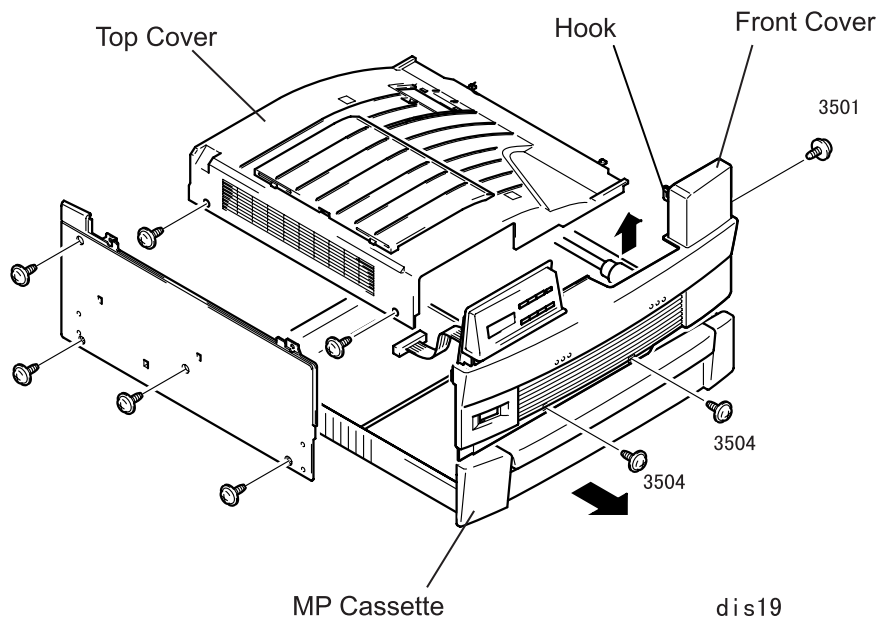

Figure 4-30. Front Cover Removal

4.2.18 Control Panel Removal

1. Remove the Top Cover. (See Section 4.2.11.)
2. Remove the Front Cover. (See Section 4.2.17.)
3. Disconnect the control panel harness connecting to the Main Circuit Board from the CN3. (See Section 4.2.13.)
4. Remove the shield cable for the control panel harness from the Main Circuit Board Mounting Plate.
5. Release the control panel harness from the cable clump.
6. Remove two screws (1308) securing the Control Panel to the printer frame and remove the Control panel.

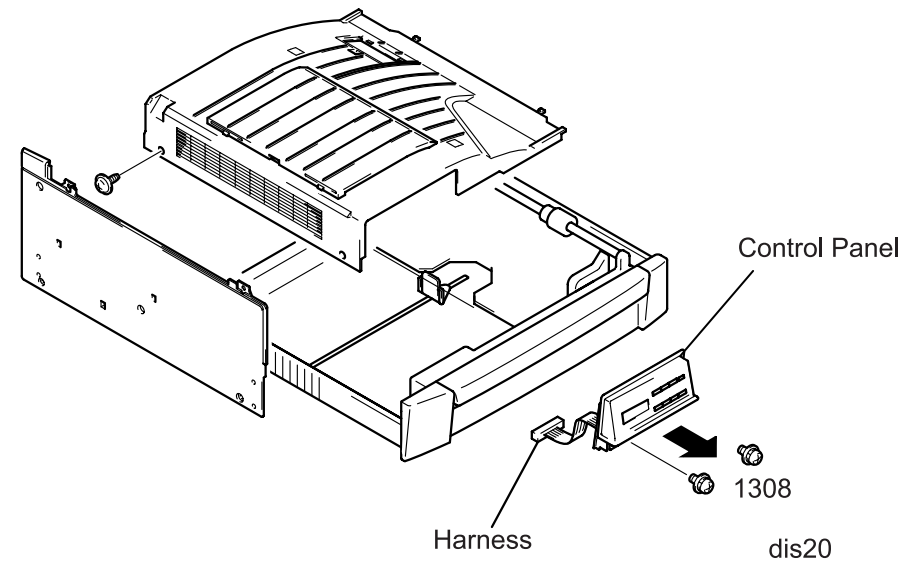

Figure 4-31. Control Panel Removal

4.2.19 Printhead Unit Removal

1. Remove the Rear Cover. (See Section 4.2.6.)
2. Remove the Top Cover. (See Section 4.2.11.)
3. Remove the Front Cover. (See Section 4.2.17.)
4. Remove the following screws and remove the Shield Cover. (See Section 4.2.13.)
 - Sixteen screws (3501: marked with A in the figure) securing the Shield Cover to the printer frame.
 - Three screws (1305: marked with B in the figure) securing the Shield Cover to the Interface bracket.
5. Remove twelve screws (1305: marked with C in the figure) securing the Main Circuit Board to the Main Circuit Board Mounting Plate.
6. Disconnect the control panel harness connecting to the Main Circuit Board from the CN3.
7. Remove seven screws (1305) securing the Interface bracket to the printer frame, and remove the Interface bracket along with the Main Circuit Board by moving it upward.
8. Remove the Engine Controller Board. (See Section 4.2.14.)
9. Remove the Control Pane. (See Section 4.2.18.)
10. Remove four screws (3541) securing the Left Cover (rail) to the printer frame and remove the left cover.
11. Remove five screws (3509) securing the lever to the printer frame and remove the lever.

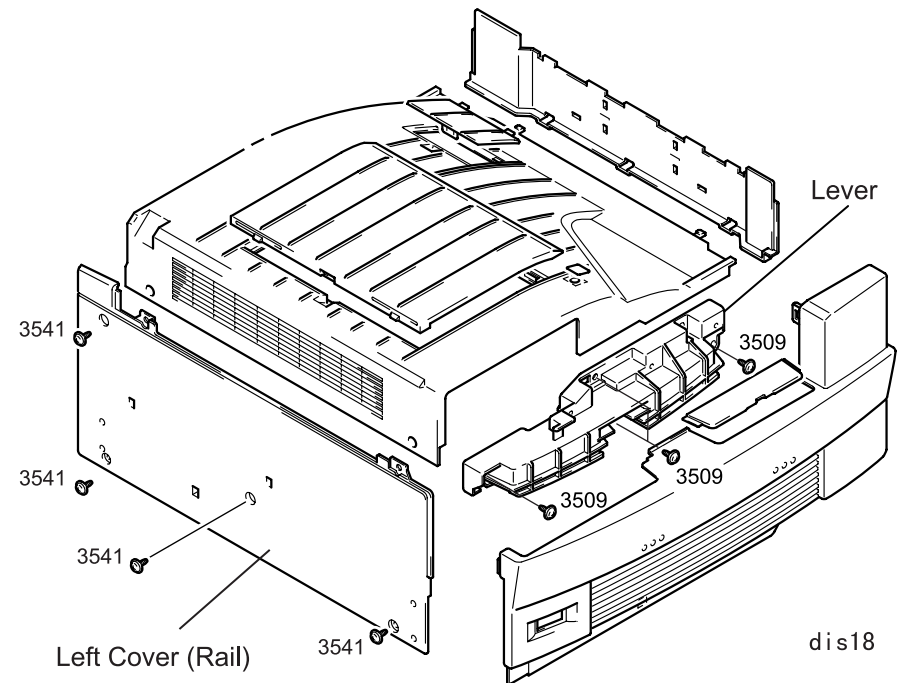

Figure 4-32. Lever / Left Cover Removal

12. Remove four screws (3501) securing the Left Reinforce Plate to the printer frame and PH Plate and remove the Left Reinforce Plate.
13. Remove four screws (3501) securing the PH Plate from the front and rear sides of the printer frame.
14. Remove one screw (3501) securing the ground wire from the Printhead Unit to the PH Plate, and remove the ground wire.
15. Remove four screws (3520) securing the Printhead Unit to the PH Plate and remove the Printhead Unit.

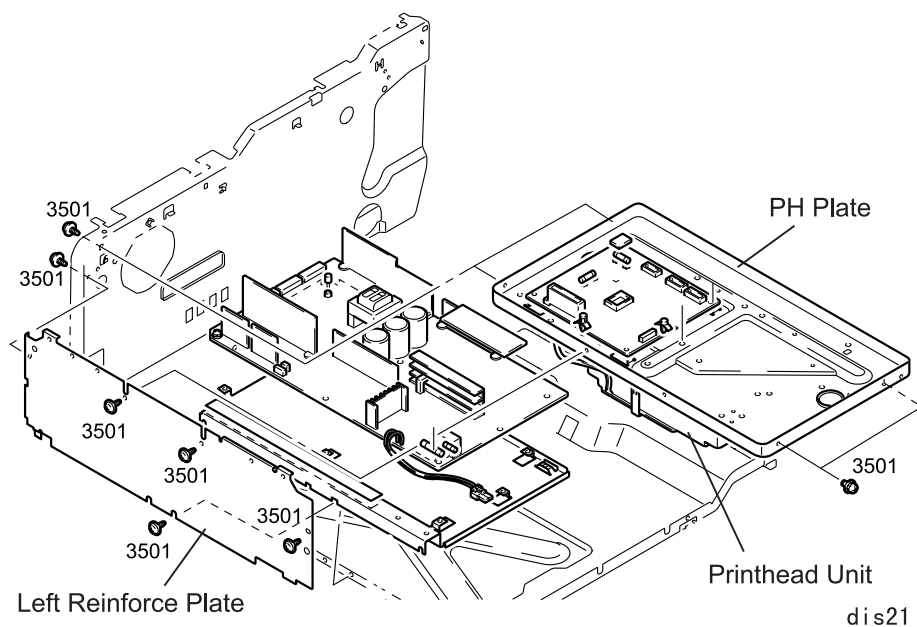

Figure 4-33. PH Plate Removal

4.2.20 Power Supply Unit Removal

1. Remove the Rear Cover. (See Section 4.2.6.)
2. Remove the Top Cover. (See Section 4.2.11.)
3. Remove the Front Cover. (See Section 4.2.17.)
4. Remove four screws (3541) securing the Left Cover (rail) to the printer frame and remove the left cover.
5. Remove four screws (3501) securing the Left Reinforce Plate to the printer frame and PH Plate and remove the Left Reinforce Plate.
6. Disconnect the harnesses from the Power Supply Board Unit.

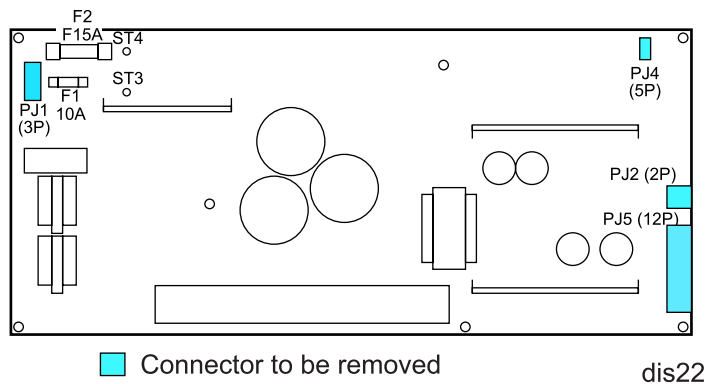

Figure 4-34. Harnesses to be Removed

7. Remove three screws; one 1305 (at the rear side of the printer) and two 3501, securing the Power Supply Board Unit Mounting Plate to the printer frame, and remove the Power Supply Unit Mounting Plate with the Power Supply Unit on it.

8. Release the harness connecting from the Power Supply Unit to the Fuser Unit from the cable clamp attached to the Power Supply Unit.
9. Remove seven screws (3501) securing the Power Supply Unit to the Power Supply Unit Mounting Plate.

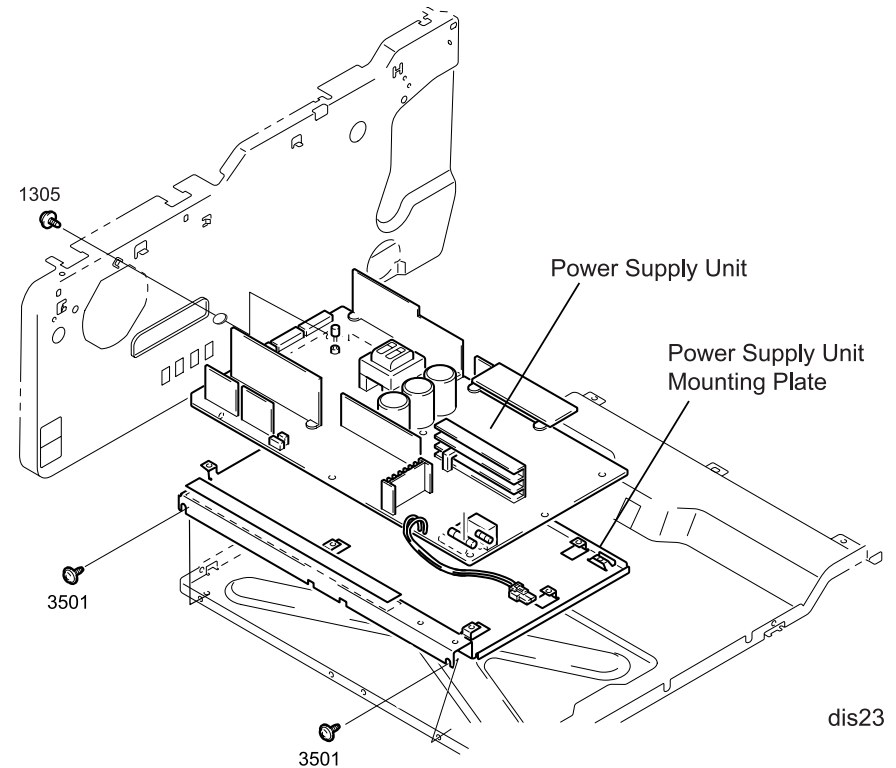
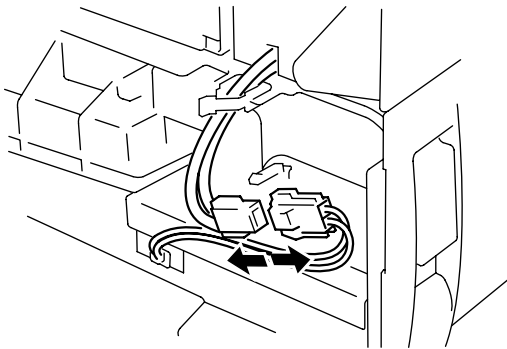

Figure 4-35. Power Supply Unit Removal

4.2.21 Fusing Section

4.2.21.1 Fuser Unit Removal

1. Open the vertical transport door. (See Section 4.2.4.)
2. Remove the Front Cover. (See Section 4.2.17.)
3. Disconnect the heater lamp harness from the connector (heater power source) on the front and release the harness from the cable clamp and edge cover which are on the printer frame.



4108d006aa

Figure 4-36. Connector (Front) Removal

4. Open the Fuser Unit and disconnect the connectors at the rear side.
5. Remove two screw (3504 and 4011) securing the Fuser Unit to the printer main body.

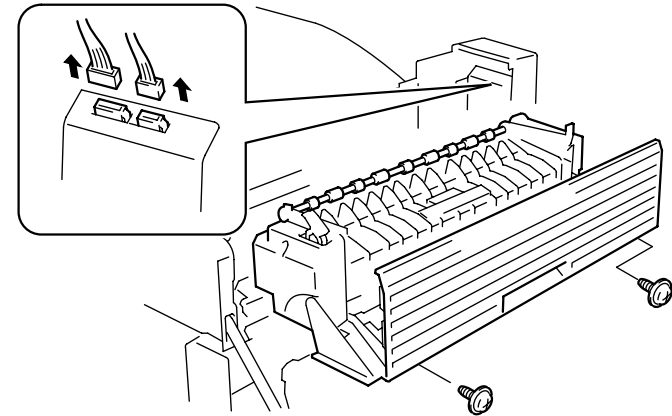

4108d007ab

Figure 4-37. Fuser Unit Removal



- The Fuser Unit is hot right after printing. Therefore, be careful not to get burnt when handling the Fuser Unit.
- If you have replaced the Fusing Unit, perform “Fuser Counter Clear” in the maintenance mode. (See Chapter 1 / Section 1.4.5.)

4.2.21.2 Heater Lamp Replacement

1. Remove the Fuser Unit. (See Section 4.2.21.1.)
2. Release the joint for the Fuser Unit Cover and the Fusing Roller Heater Lamp Front Cover.
3. Remove one screw (3501) securing the Fusing Roller Heater Lamp Front Cover to the Fuser Unit Frame Assembly, and remove the Fusing Roller Heater Lamp Front Cover.

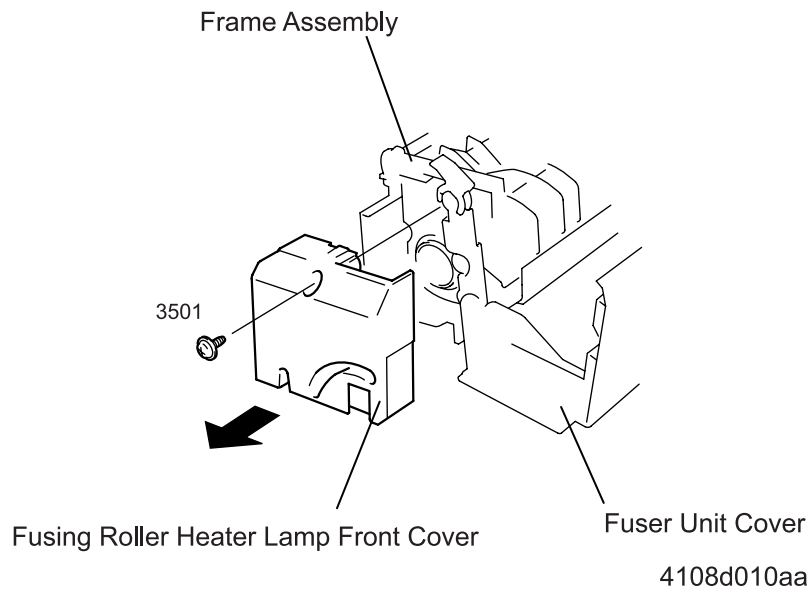

Figure 4-38. Fuser Heater Lamp Front Cover Removal

4. Remove one screw (1305) securing the Heater Lamp Holder (front) to the Fuser Unit Frame Assembly, and remove the Heater Lamp Holder and the Heater Lamp.

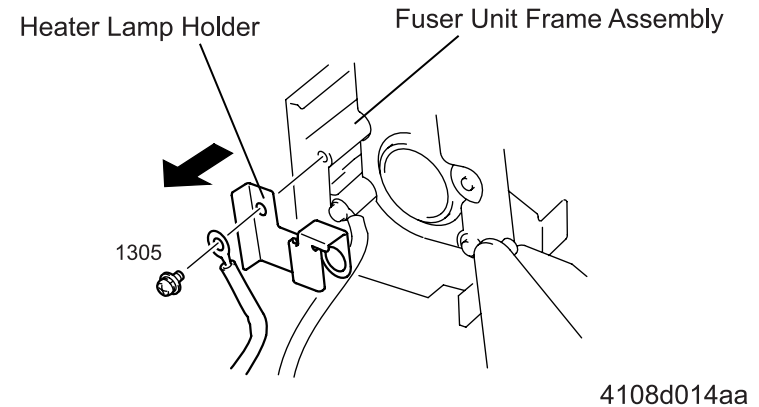

Figure 4-39. Heater Lamp Removal



- Do not touch the glass tube in the Fusing Roller Heat Lamp.
- When installing the Fusing Roller Heater Lamp, set it with the voltage marking facing to the gear side (the other side of the Heater Lamp Front Cover).

4.2.21.3 Fusing Roller Thermistor / Thermostat / Temperature Fuse Removal

1. Remove the Fuser Unit. (See Section 4.2.21.1.)
2. Release the joint for the Fuser Unit Cover and the Fusing Roller Heater Lamp Front Cover.
3. Remove one screw (3501) securing the Fusing Roller Heater Lamp Front Cover to the Fuser Unit Frame Assembly, and remove the Fusing Roller Heater Lamp Front Cover. (See Section 4.2.21.2.)
4. Remove one E-ring (9107) and one tension spring securing the lever to the rear part of the Fuser Unit, and remove the lever.

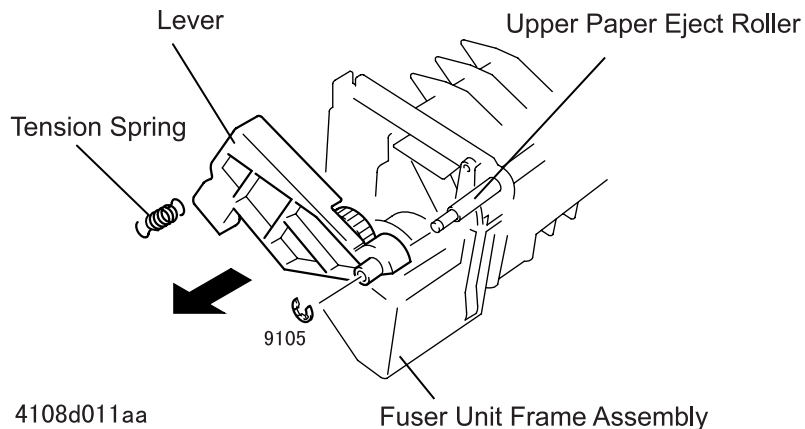

Figure 4-40. Lever Removal

5. Release the thermistor harness and paper eject sensor harness from the clamps in the Fusing Roller Heater Lamp Rear Cover.
6. Remove one screw (3501) securing the Fusing Roller Heater Lamp Rear Cover to the User Unit Frame Assembly, and remove the Fusing Roller Lamp rear Cover.

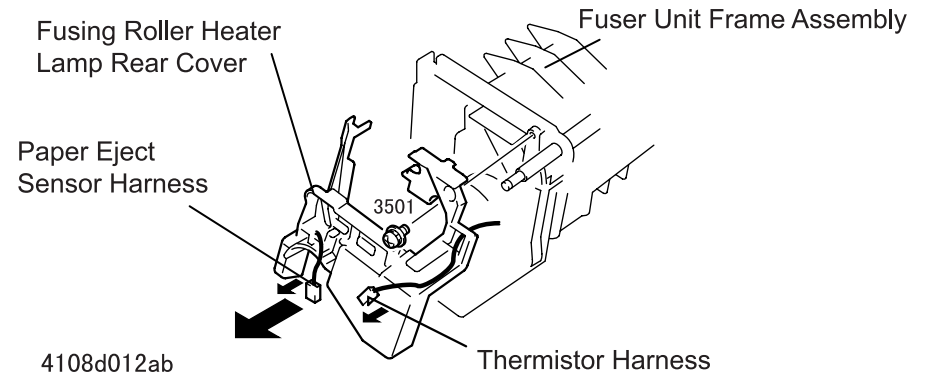

Figure 4-41. Fusing Roller Heater lamp Rear Cover Removal

7. Remove two screws (1305) securing the Fusing Roller Heater Lamp Holder to the Fuser Unit Frame Assembly, and remove the Fusing Roller Heater Lamp Holder.
8. Pull out the Heater Lamp.

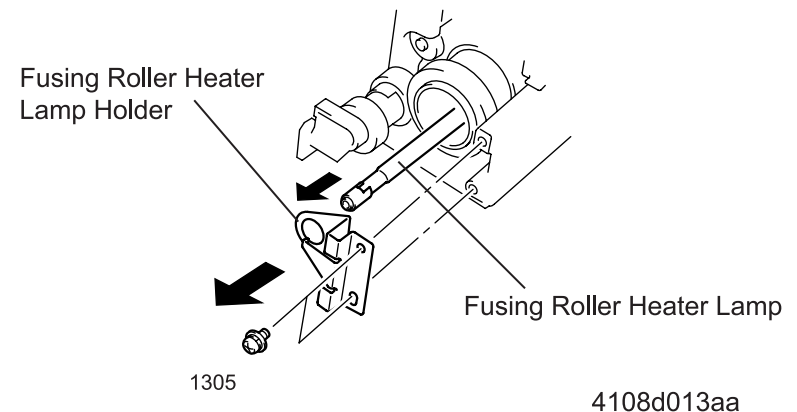

Figure 4-42. Fusing Roller Heater Lamp Holder Removal

9. Remove one screw (1305) securing the Heater Lamp Holder (front) to the Fuser Unit Frame Assembly and remove the Heater Lamp Holder and Heater Lamp. (See Section 4.2.21.2.)
10. Remove one E-ring (9107) fixing the Fuser Unit Cover to the shoulder screw on the rear frame of the User Unit. Then release the Fuser Unit Cover from the shoulder screws on the right and left frame of the Fuser Unit.
11. Remove the shoulder screws securing the right and left levers to the front and rear frames in the Fuser Unit, and remove the levers along with the torsion spring, spacers and Front Guide Plate.
12. Remove two screws (1305) securing the Upper Paper Separator Finger Assembly to the front and rear frames in the Fuser Unit and remove the Upper Paper Separator Finger Assembly.

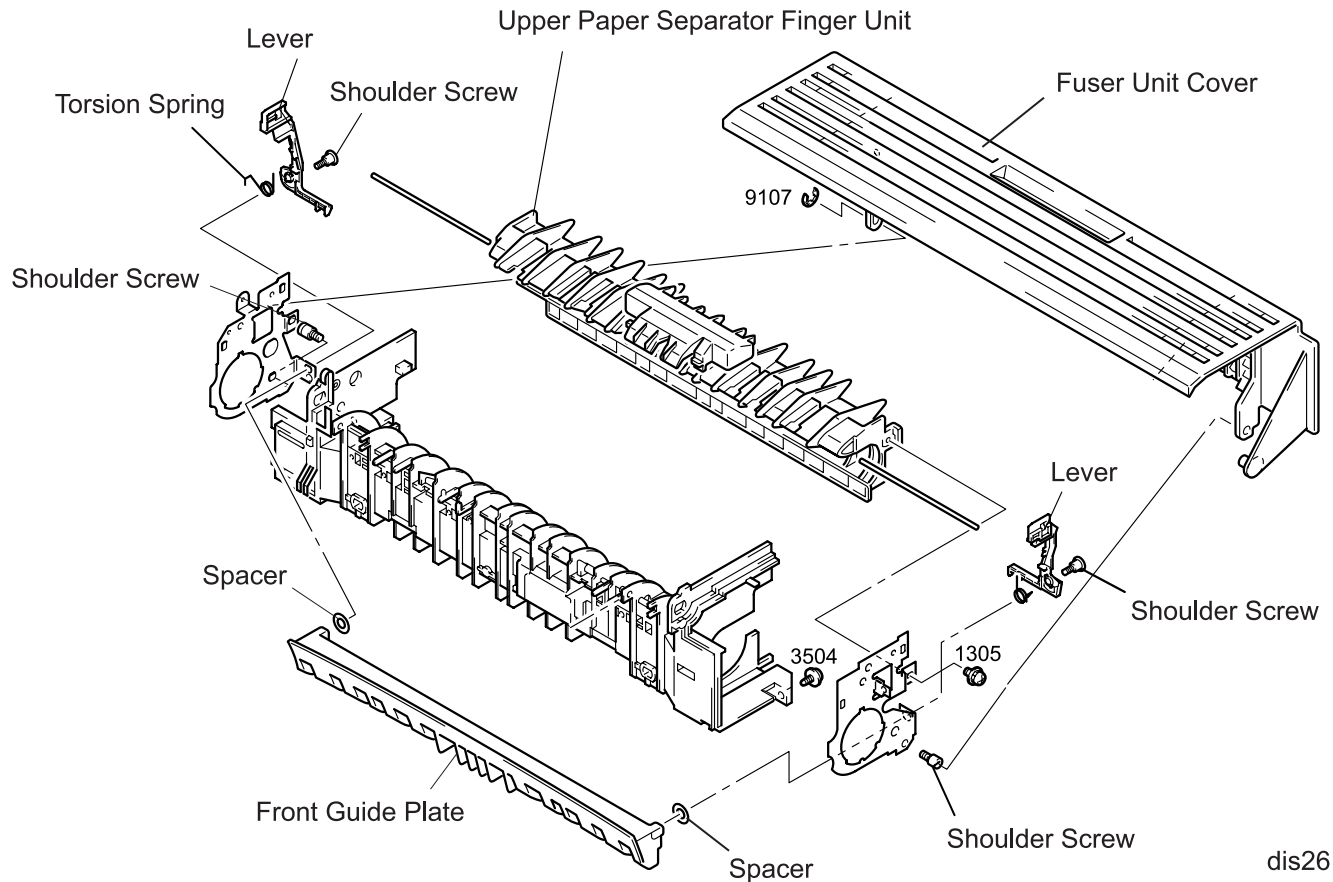
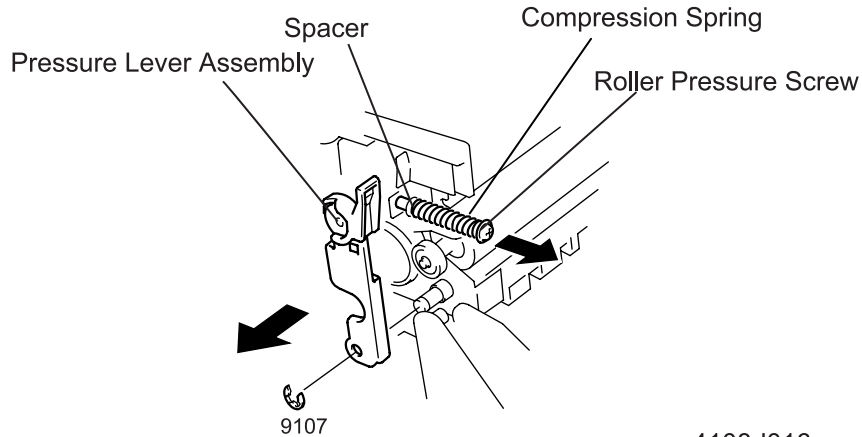

Figure 4-43. Upper Paper Separator Finger Assembly Removal

13. Remove one pressure spring on the front, E-ring (9107), and remove the yellow Pressure Lever Assembly.



4108d016aa

Figure 4-44. Front Pressure Lever Removal

14. Remove the Upper Fusing Roller and the bearings.

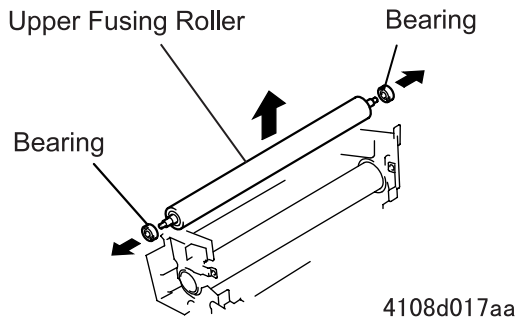

4108d017aa

Figure 4-45. Upper Fusing Roller Removal

15. Remove two C-rings attached to the front and rear ends of the Lower Fusing Roller.

16. Remove the Lower Fusing Roller by pulling it out from the gear side.

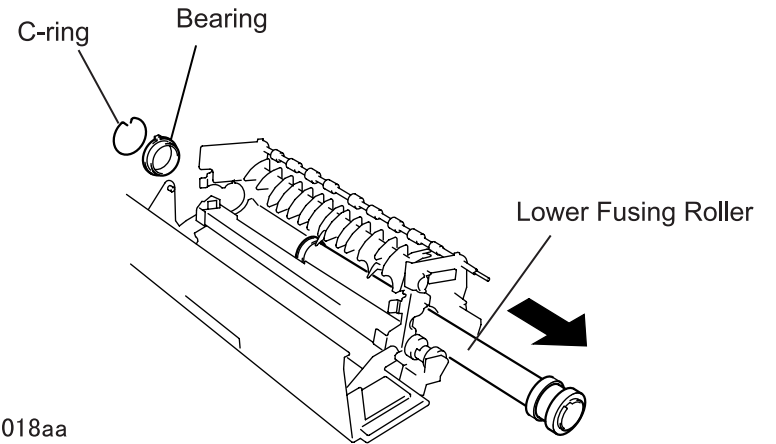

4108d018aa

Figure 4-46. Lower Fusing Roller Removal

17. Remove one screw (1309) securing the Fusing Roller Thermistor to the Fuser Unit Frame Assembly and remove the Fusing Roller Thermistor.

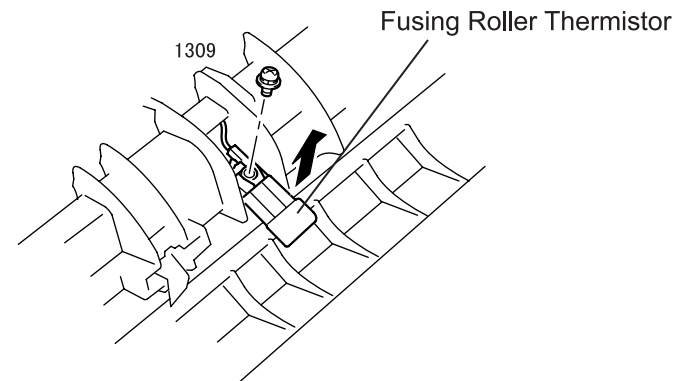

4108d019aa

Figure 4-47. Fusing Roller Thermistor Removal

- Remove two screws (1305) securing the Fusing Roller Thermostat to the Fuser Unit Frame Assembly and remove the Fusing Roller Thermistor.

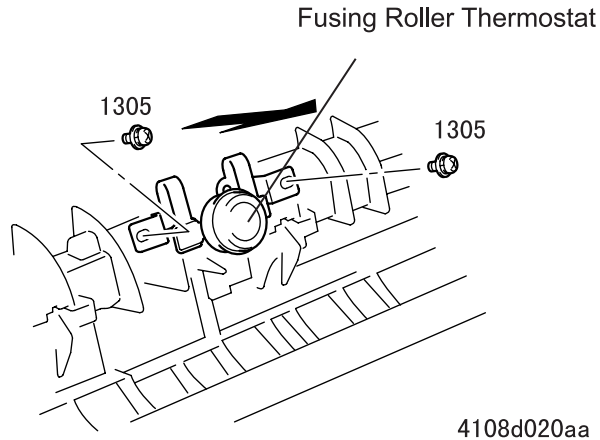

Figure 4-48. Fuser Lamp Termistor Removal

- Remove two screws (1305) securing the Fusing Roller Temperature Fuse to the Fuser Unit Frame Assembly and remove the Fusing Roller Temperature Fuse.

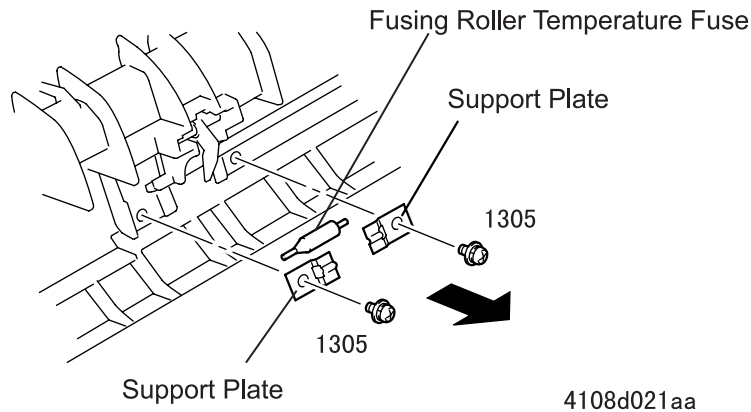

Figure 4-49. Fusing Roller Temperature Fuse Removal

4.2.21.4 Upper Paper Separator Finger Removal

- Remove the Upper Paper Separator Finger Assembly. (See Section 4.2.21.4.)
- Slide the fixing shaft from the Upper Paper Separator Finger Assembly and remove the Upper Paper Separator Fingers.

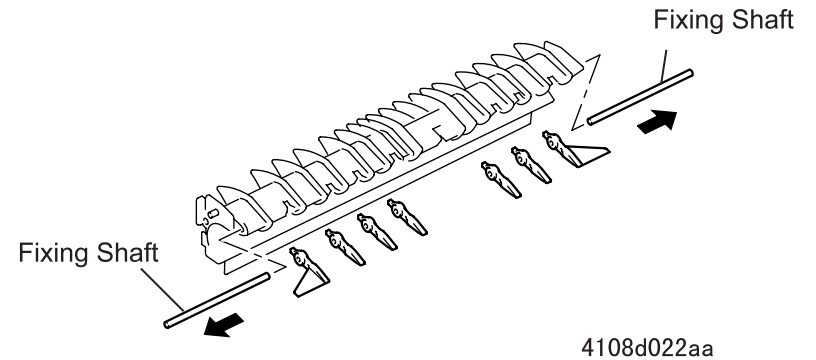
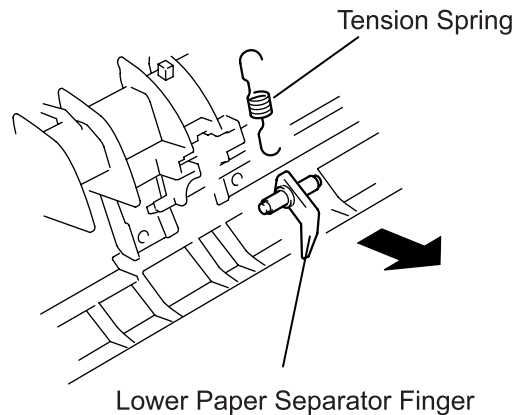

Figure 4-50. Upper Paper Separator Finger Removal

4.2.21.5 Lower Paper Separator Finger Removal

1. Remove the Lower Fusing Roller. (See Section 4.2.21.3.)
2. Remove the tension spring fixing the Lower Paper Separator Finger to the Fuser Unit Frame.



4108d023ab

Figure 4-51. Lower Paper Separator Finger Removal

4.2.21.6 Upper Paper Eject Roller Removal

1. Remove the Fuser Unit. (See Section 4.2.21.1.)
2. Release the joint for the Fuser Unit Cover and the Fusing Roller Heater Lamp Front Cover.
3. Remove one screw (3501) securing the Fusing Roller Heater Lamp Front Cover to the Fuser Unit Frame Assembly, and remove the Fusing Roller Heater Lamp Front Cover. (See Section 4.2.21.2.)
4. Remove one E-ring (9107) and one torsion spring securing the lever to the rear part of the Fuser Unit and remove the lever.
5. Release the thermistor harness and paper eject sensor harness from the cable clamps in the Fusing Roller Heater Lamp Rear Cover.
6. Remove one screw (3501) securing the Fusing Roller Heater Lamp Rear Cover to the Fuser Unit Frame Assembly and remove the Fusing Roller Heater Lamp Rear Cover.
7. Remove two E-rings (9107) and two bushings fixing the Upper Paper Eject Roller to the Fuser Unit Frame Assembly and remove the Upper Paper Eject Roller.

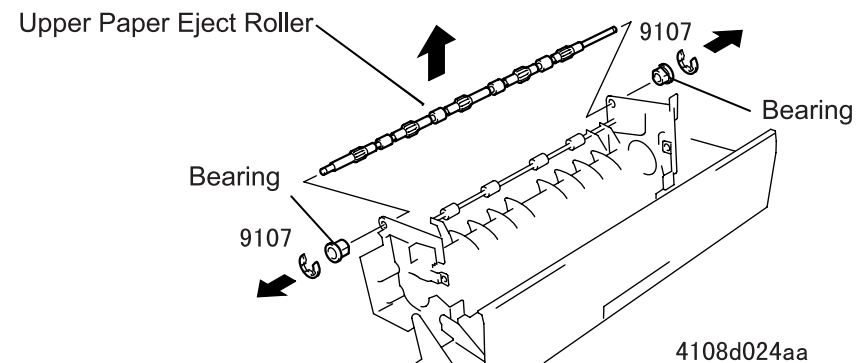

4108d024aa

Figure 4-52. Upper Paper Eject Roller Removal

4.2.21.7 Lower Paper Eject Roller Removal

1. Remove the Fuser Unit. (See Section 4.2.21.1.)
2. Remove the Upper Paper Eject Roller. (See Section 4.2.21.6.)
3. Remove one E-ring (9102) securing the Lower Paper Eject Roller to the Fuser Unit Frame Assembly and two torsion springs, and remove the Lower Paper Eject Roller.

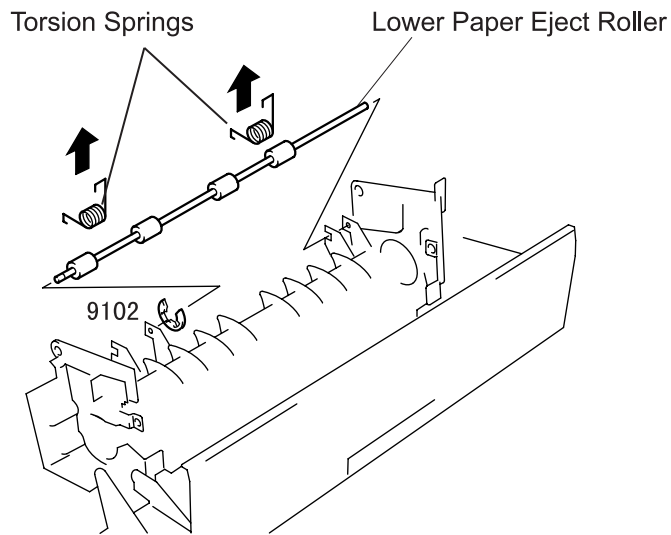

4108d025aa

Figure 4-53. Lower Paper Eject Roller Removal

4.2.22 Drive Unit Removal

1. Separate the printer. (See Section 4.2.6.)
2. Remove the Rear Cover. (See Section 4.2.6.)
3. Remove the Top Cover. (See Section 4.2.11.)
4. Remove the Front Cover. (See Section 4.2.17.)
5. Remove the Transport Motor. (See Section 4.2.7.)
6. Remove the I/C Drive Motor. (See Section 4.2.8.)
7. Remove the Fuser Unit. (See Section 4.2.21.1.)
8. Disconnect the fusing roller thermistor harness and the paper eject sensor harness which are connecting to the Fuser Unit Reinforce Plate from the relay connectors.
9. Remove 5 screws (3506; two at the front and three at the rear) securing the Fuser Unit Reinforce Plate to the printer frame, and remove the Fuser Unit Reinforce Plate. (See Figure 4-54.)
10. Remove three screws (3501) securing the Drive Unit Cover (mounting plate) to the printer frame and remove the mounting plate. (See Figure 4-55.)

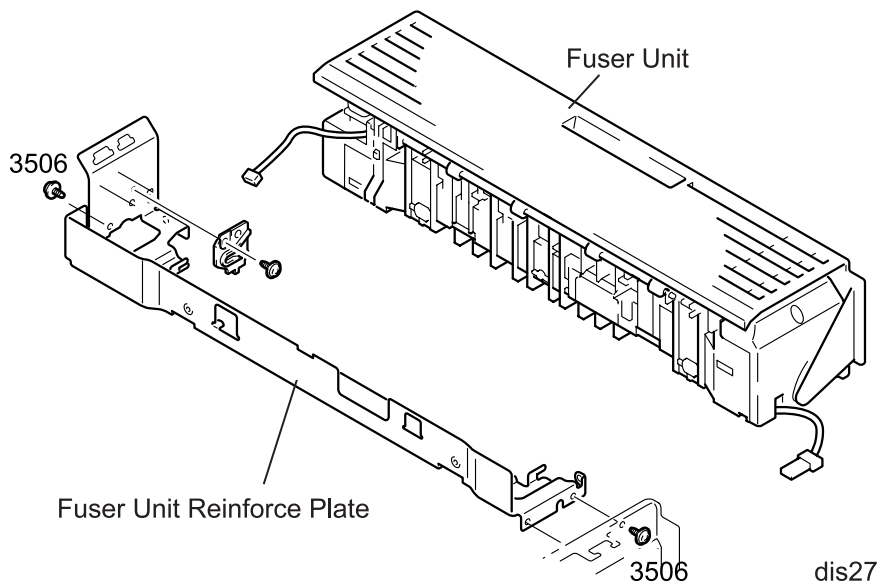

Figure 4-54. Fuser Unit Reinforce Plate Removal

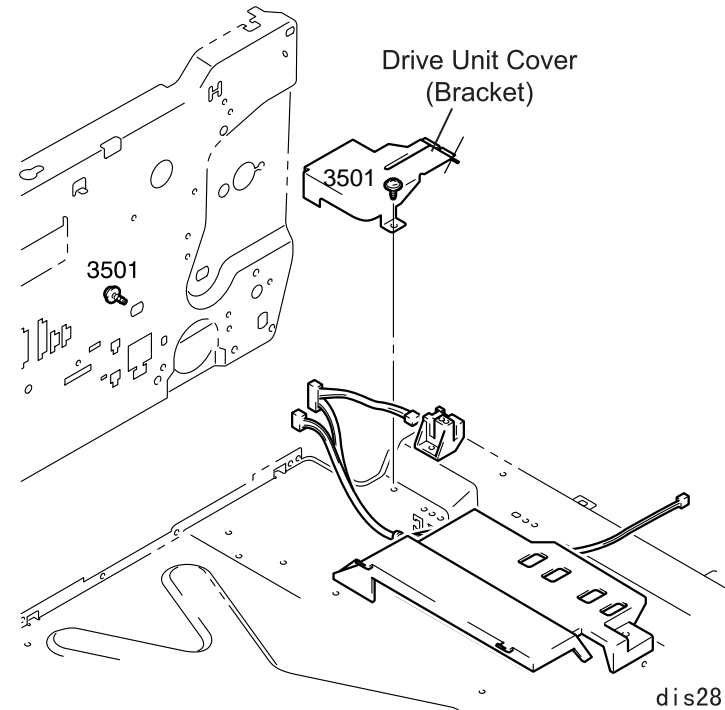

Figure 4-55. Drive Unit Cover Removal

11. Remove one retaining ring (9302) fixing the bushing to the bracket for the Gear (49T) and remove the bushing.
12. Release the harness from the clamp attached to the bracket for the Gear (49T).
13. Remove the harness for the MP Cassette Paper Take-up Solenoid (SL1).
14. Remove one retaining ring (9301) from the MP Cassette Paper Take-up Roller Drive Shaft and remove the bushing.
15. Inserting a hand from the bottom of the printer, remove one C-clip attached to the Transport Transmission Gear, and remove the Transport Transmission Gear and the bushing from the Driver Unit.
16. Disconnect the harness for the MP Cassette Set Sensor (PC6) from the connector on the sensor.
17. Remove nine screws (3708) securing the Drive Unit to the printer frame, and remove the Drive unit.

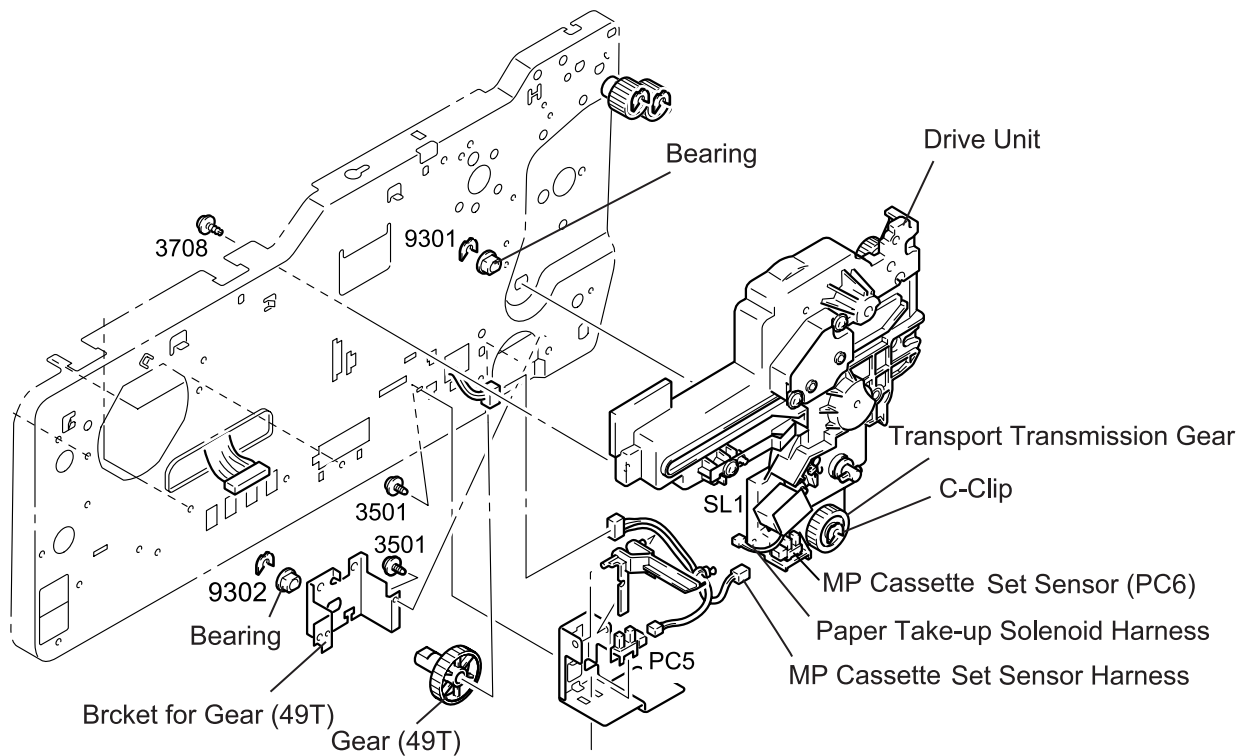
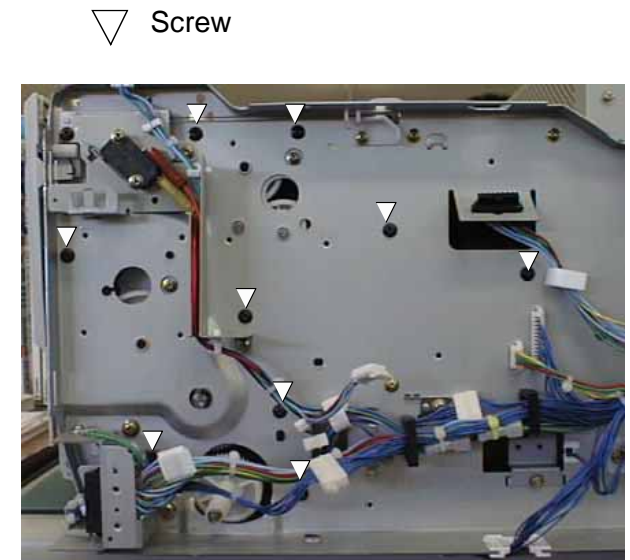

Figure 4-56. Drive Unit Removal

dis29



dis31

Figure 4-57. Drive Unit Screw Location

4.2.22.1 MP Cassette Paper Take-up Solenoid (SL1) Removal

1. Separate the printer. (See Section 4.2.6.)
2. Remove the Drive Unit. (See Section 4.2.22.)
3. Remove one screw (3704) securing the solenoid and the solenoid cover to the Drive Unit, and remove the solenoid cover.

MP Cassette Paper Take-up Solenoid,
Solenoid Cover



Mounting Screw

dis30

Figure 4-58. MP Cassette Paper Take-up Solenoid Removal

4.2.22.2 MP Cassette Set Sensor Removal

1. Separate the printer. (See Section 4.2.6.)
2. Remove the Drive Unit. (See Section 4.2.22.)
3. Unhook the MP Cassette Set Sensor from the frame in the Drive Unit and remove the MP Cassette Set Sensor.

4.2.22.3 MP Cassette Paper Empty Sensor Removal

1. Separate the printer. (See Section 4.2.6.)
2. Remove one screw (3708) securing the MP Cassette Paper Empty Sensor to the printer frame and remove the MP Cassette Paper Empty Sensor and the sensor cover.
3. Unhook the MP Cassette Paper Empty Sensor from the sensor cover and separate the MP Cassette Paper Empty Sensor.
4. Remove the harness for the MP Cassette Paper Empty Sensor from the connector.

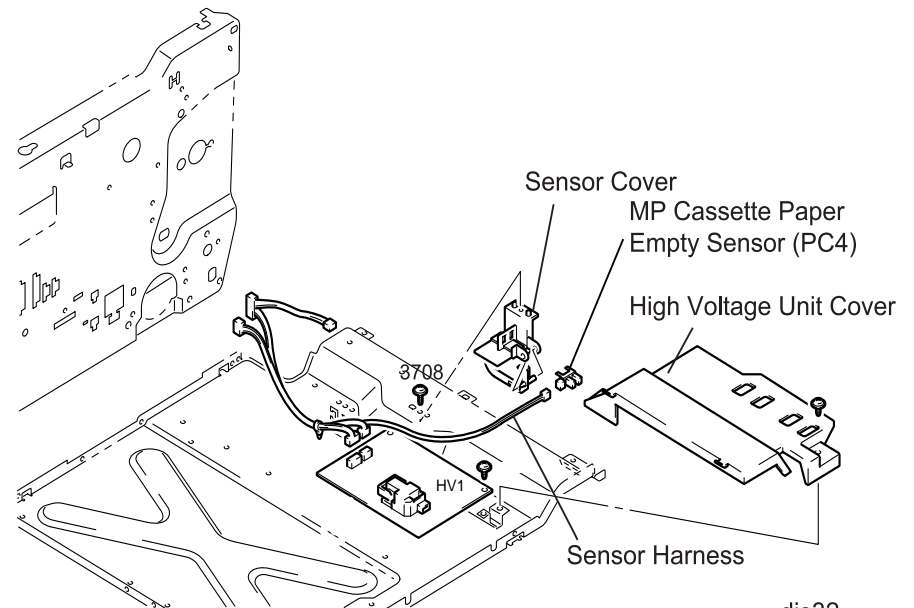

dis32

Figure 4-59. MP Cassette Paper Empty Sensor Removal

4.2.22.4 MP Cassette Paper Near Empty Sensor Removal

1. Separate the printer. (See Section 4.2.6.)
2. Remove one screw (3501) securing the bracket for the MP Cassette Paper Near Empty Sensor and remove the MP Cassette Paper Near Empty Sensor along with the bracket.
3. Remove the cover from the bracket.
4. Remove the harness from the connector on the sensor.

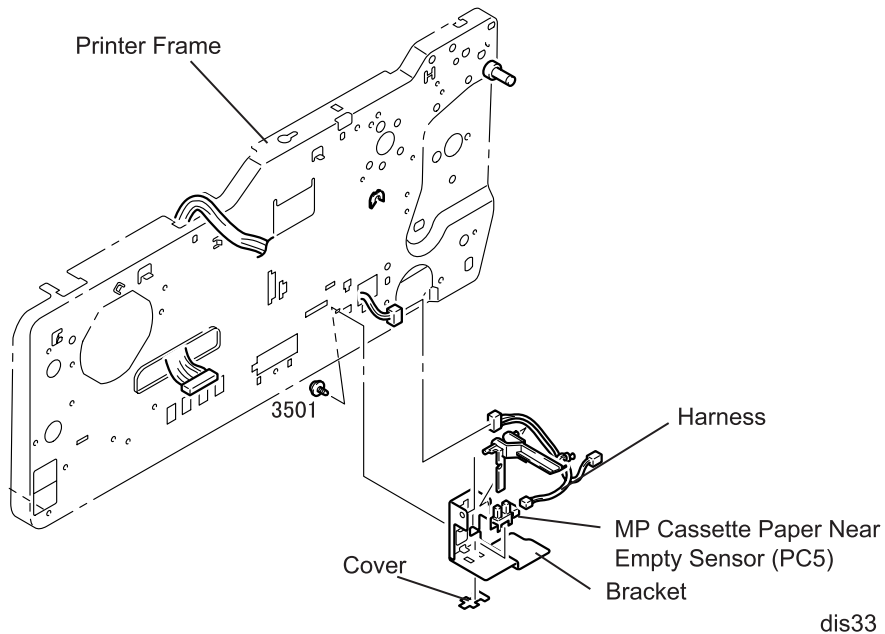

Figure 4-60. MP Cassette Paper Near Empty Sensor Removal

4.2.23 Cassette 1 Disassembly

4.2.23.1 Paper Take-up Roller Removal

1. Separate the printer. (See Section 4.2.6.)
2. Unlock the Paper Take-up Roller. Then slide the Paper Take-up Roller along the shaft plate and remove it.



If you have replaced the Paper Take-up Roller, be sure to perform “LC1 Counter Clear” in the maintenance mode. (See Chapter 1 / Section 1.4.5.)

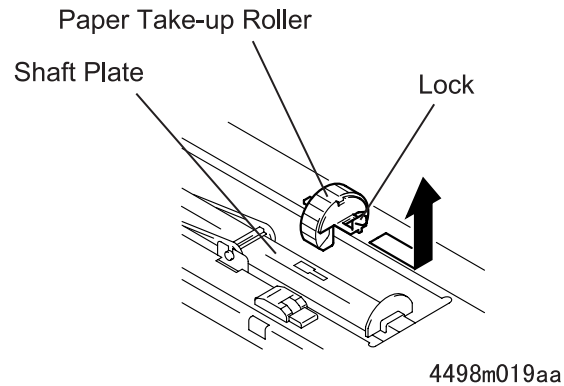
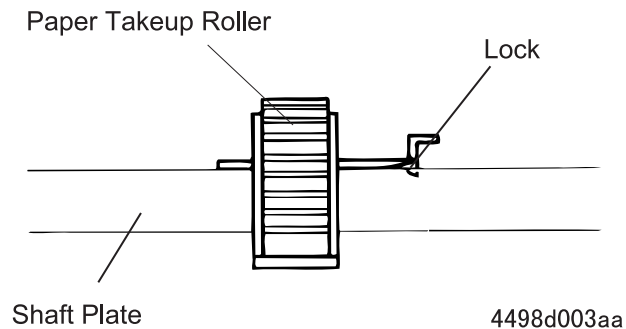

Figure 4-61. Paper Take-up Roller Removal



When installing the Paper Take-up Roller, make sure the roller is securely locked as shown below.



4.2.23.2 Cassette 1 Paper Empty Sensor Removal

1. Take out the Cassette 1.
2. Separate the printer. (See Section 4.2.6.)
3. Release three hooks attaching the holder to the Guide Plate and remove the holder.
4. Remove one screw (3501) securing the bracket for the Cassette 1 Paper Empty Sensor to the Guide Plate and remove the bracket.
5. Remove the stopper for the Cassette 1 Paper Empty Sensor and remove the Cassette 1 Paper Empty Sensor.
6. Remove the harness from the Cassette 1 Paper Empty Sensor.

4.2.23.3 Cassette 1 Paper Near Empty Sensor Removal

1. Take out the Cassette 1.
2. Separate the printer. (See Section 4.2.6.)
3. Release three hooks attaching the holder to the Guide Plate and remove the holder.
4. Remove one screw (3501) securing the bracket for the Cassette 1 Paper Near Empty Sensor to the Guide Plate and remove the bracket.
5. Remove the stopper for the Cassette 1 Paper Empty Sensor and remove the Cassette 1 Paper Near Empty Sensor.
6. Remove the harness from the Cassette 1 Paper Near Empty Sensor.

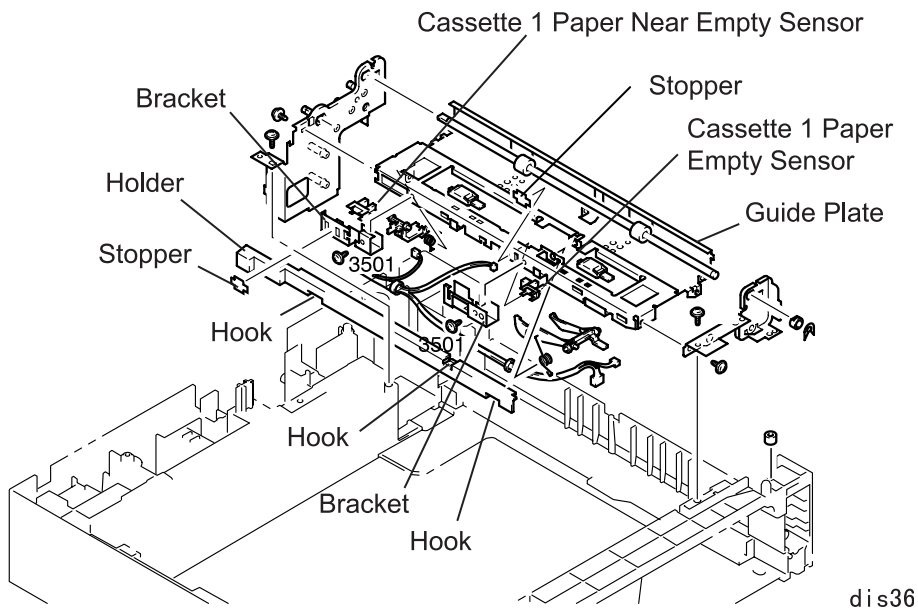

Figure 4-62. Cassette 1 Paper Empty Sensor Removal

4.2.23.4 Paper Size (Paper Size Switch) Sensor Removal

1. Take out the Cassette 1.
2. Separate the printer. (See Section 4.2.6.)
3. Remove three screw (3704) securing the bracket for the Paper Size Sensor to the frame in the Cassette 1 and remove the Paper Size Sensor along with the bracket.
4. Remove one screw (3501) securing the Paper Size Sensor Cover to the bracket and remove the Paper Size Sensor Cover from the bracket.
5. Release the hook attaching the Paper Size Sensor to the bracket at the inner side and remove the Paper Size Sensor from the bracket.
6. Remove the harness from the Paper Size Sensor.

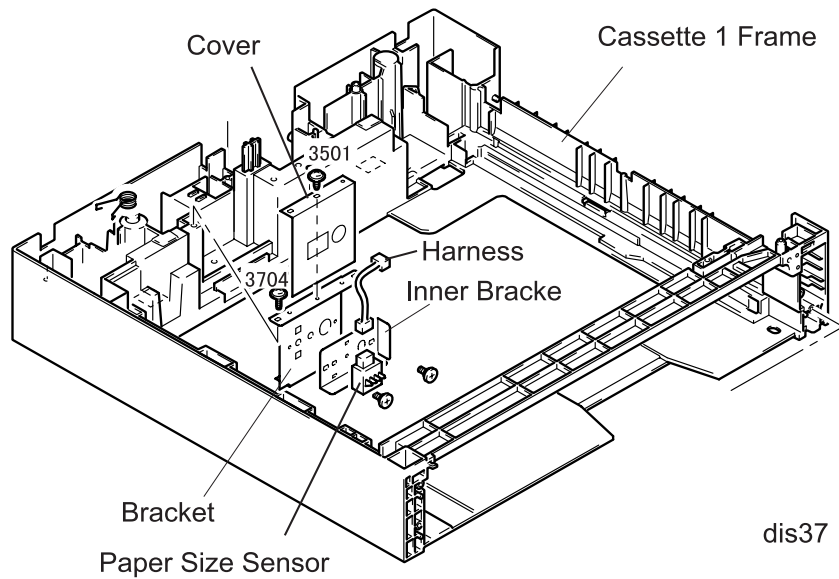

Figure 4-63. Paper Size Sensor Removal

4.2.23.5 Cassette 1 Control Board (PWB-A) Removal

1. Take out the Cassette 1.
2. Separate the printer. (See Section 4.2.6.)
3. Remove harnesses from the connectors on the Cassette 1 Control Board.
4. Remove two screws (3501) securing the Cassette 1 Control Board to the bracket and bracket support and remove the Cassette 1 Control Board.

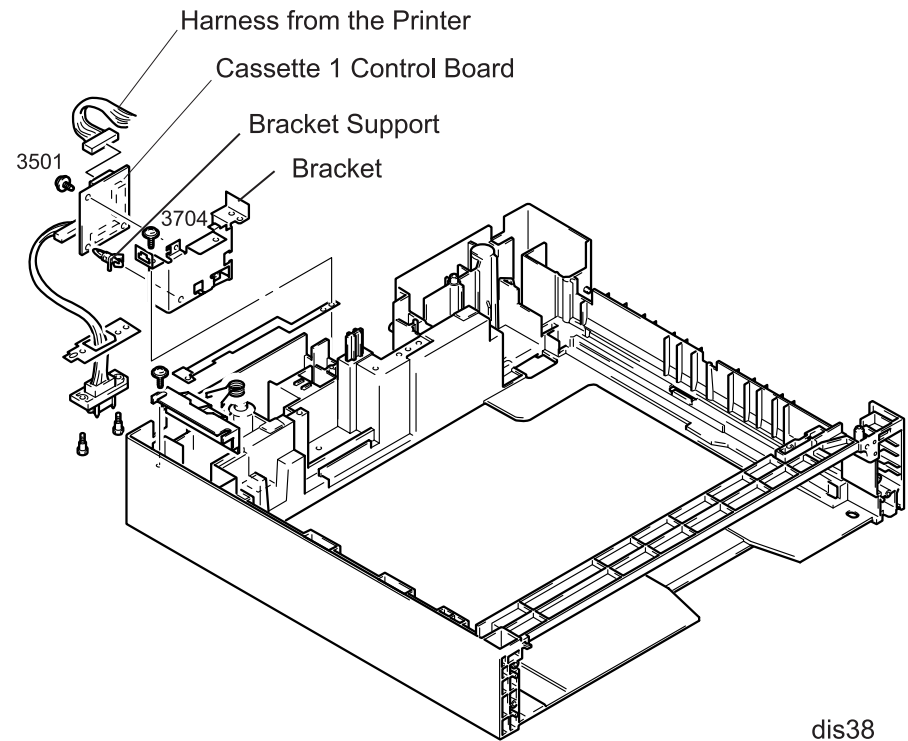

Figure 4-64. Cassette 1 Control Board Removal

4.2.23.6 Cassette 1 Paper Take-up Solenoid Removal

1. Take out the Cassette 1.
2. Separate the printer. (See Section 4.2.6.)
3. Remove the tension spring hung to the gear (31T).
4. Remove one screw (3501) securing the Cassette 1 Paper Take-up Solenoid Cover to the bracket and remove the Cassette 1 Paper Take-up Solenoid Cover.
5. Remove one screw (3501) securing the Cassette 1 Paper Take-up Solenoid to the bracket and remove the Cassette 1 Paper Take-up Solenoid from the bracket.
6. Remove the harness for the Cassette 1 Paper Take-up Solenoid from the connector.

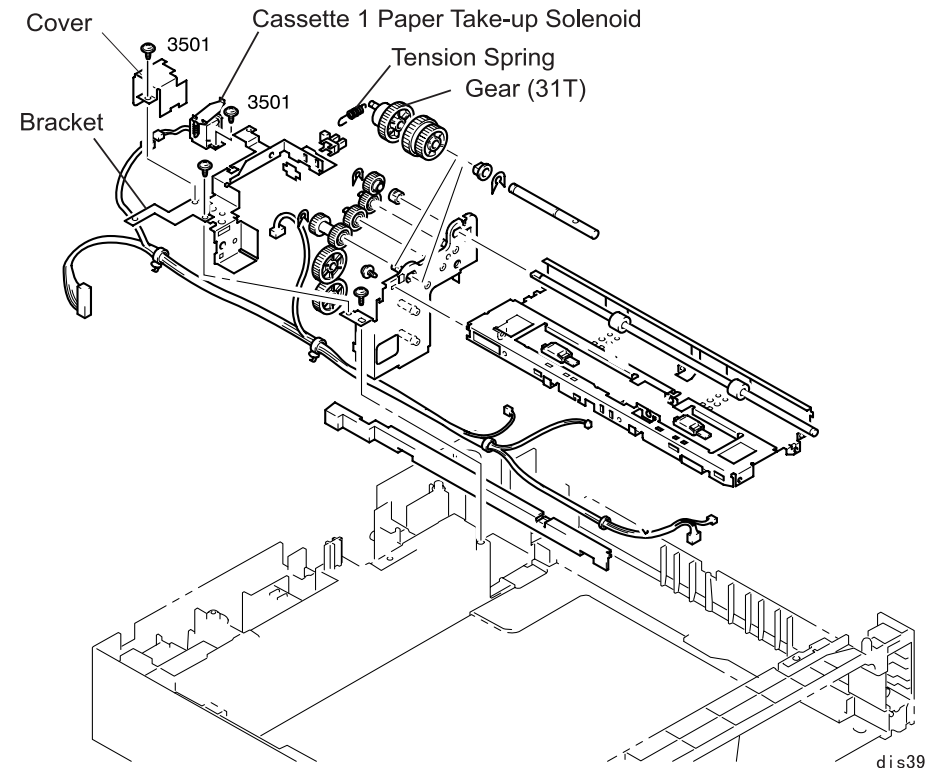

Figure 4-65. Cassette 1 Paper Take-up Solenoid Removal

4.2.23.7 Cassette 1 Right Door Set Sensor Removal

1. Take out the Cassette 1.
2. Separate the printer. (See Section 4.2.6.)
3. Remove the tension spring hung to the gear (31T).
4. Remove two screws (3704) securing the bracket for the Cassette 1 Control Board to the Cassette 1 Frame, and remove the bracket. (See Section 4.2.23.5.)
5. Remove one screw (3501) securing the Plate Spring to the bracket and remove the Plate Spring from the bracket.
6. Remove the following screws:
 - Two screws (3501) securing the solenoid bracket to the Cassette 1 Frame
 - Four screws (3704) securing the Paper Take-up Mechanism (Shaft Plate, Guide Plate, and Bracket) to the Cassette 1 Frame
 - One screw (3501) securing the rail and Shaft Plate
7. Lift up the Paper Take-up Mechanism and the solenoid bracket.
8. Remove two screws (3501) securing the Solenoid Bracket to the Paper Take-up Mechanism and remove the Solenoid Bracket from the Paper Take-up Mechanism.
9. Remove the stopper fixing the Cassette 1 Right Door Set Sensor to the Solenoid Bracket.
10. Unhook the Cassette 1 Right Door Set Sensor from the Solenoid Bracket and remove the Cassette 1 Right Door Set Sensor.

11. Remove the harness from the connector on the Cassette 1 Right Door Set Sensor.

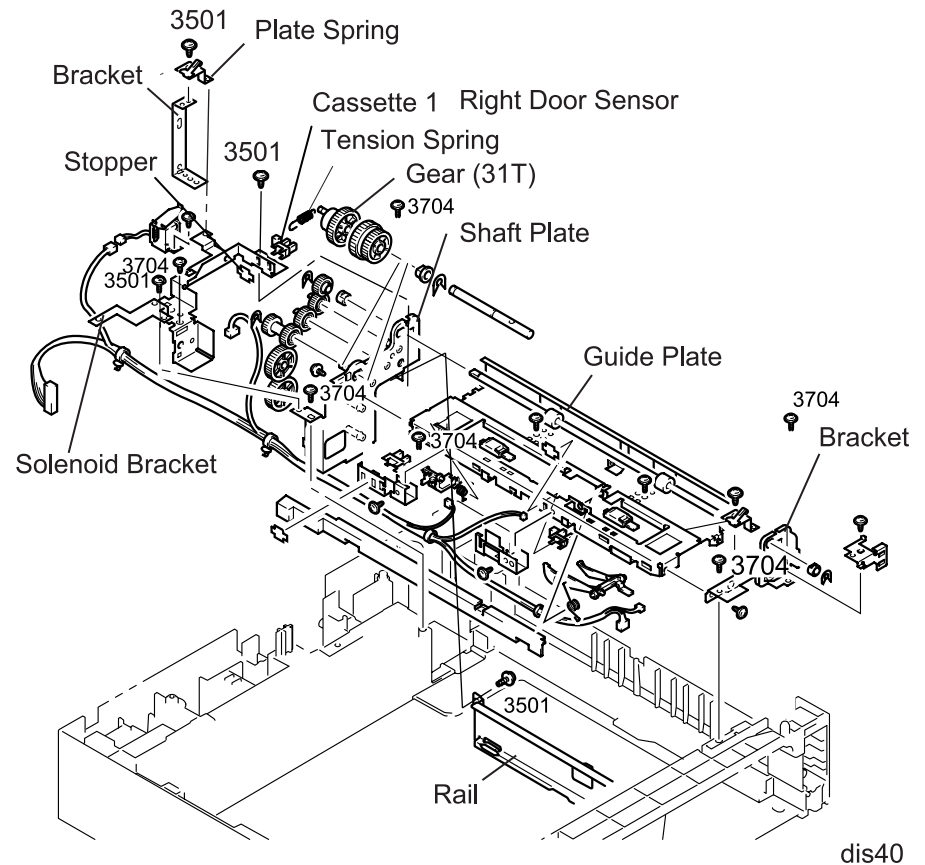

Figure 4-66. Cassette 1 Right Door Set Sensor Removal

4.2.24 Updating the Firmware

The firmware for this printer is stored in the DIMM on the Main Circuit Board. The following sections describe two different updating method. (Refer to Chapter 1.)

4.2.25 Updating the Program ROM

This method involves downloading the firmware from a parallel interface.

1. Make sure the firmware (a file with the extension code “.crb”) is saved in the hard disc of the PC.
2. Connect the printer with the PC using a parallel interface cable.
3. On Windows system, click Start / Settings / Printer, and set this printer as default. then set the printer port to LPT1 (or corresponding port).
4. While holding down the buttons On Line, Alt, and Value on the control panel, turn the printer on.
The messages below consequently appear and enters ready status.
“Program Device” → “Version *.*” → “Please Send Data”



To cancel this function at this point, turn the printer power off. The contents of the firmware remain old.

5. Type the following command line to transfer the new firmware.
> copy_*.crb_lpt1 [Return]

6. When the message “OLD: **** NEW:****” appears, press the Enter button. As the message below appears, the firmware update begins.



- **To cancel the updating at this point, press the Menu button. The message “WAIT RESET” appears and the contents of the firmware remain old.**
- **Once the Enter button is pressed, the updated contents can not be returned to the old status.**

7. If the message “Check Sum ROM Data” appears, it means the new program has been properly transferred. Then turn the printer off and back on or press the Enter button to boot the printer, and the printer is in the ready status. After this point, the printer operates with the new firmware.

4.2.25.1 Error Indications and Measures

- A different type of firmware has been transferred.

After data transfer, the printer displays the following message before version confirmation:

“<END : CMD Error : CONT>”.

- If the **Menu** button is pressed, the message “WAIT RESET” appears, and the contents of the firmware remain old.
- If the **Enter** button is pressed, the rewriting job continues and is done properly, but the printer does not operate.

- CRB file does not exist in the data file.

After data transfer, the printer displays the following message before version confirmation:

“<END : CMD Error : CONT>”.

- If the **Menu** button is pressed, the message “WAIT RESET” appears and the contents of the firmware remain old.

- If the **Enter** button is pressed, the rewriting job continues, but stops again with the error.
- Verify error during updating or erasing

The verify error occurs while the DIMM is being rewritten or writing address is out of range. The printer displays the following message:
“<END : Write. ER : CONT>”.

The cause of the error is improper pin connection of the DIMM or the DIMM malfunction.

 - If the **Menu** button is pressed, the message “WAIT RESET” appears and the contents of the firmware remain old.
 - If the **Enter** button is pressed, the rewriting job continues, but there is a possibility the printer will not boot due to Check Sum error.
- Writing address to the DIMM is out of range.

The printer displays the following message:

“<END : ADR. Error : CONT>”

The possible cause of the error is:

The data sent from the PC has converted and the contents are different from the data file.

There is a problem with the contents of the data file.

- If the **Menu** button is pressed, the message “WAIT RESET” appears and the contents of the firmware remain old.
- If the **Enter** button is pressed, the rewriting job continues, but soon stops again with the error.

- Check sum of the writing data record does not match.

The printer displays the following message:

“<END : Data. Error : CONT>”

The possible cause of the error is:

The data sent from the PC has converted, and the contents are different from the one is the data file.

There is a problem with the contents of the data file.

- If the **Menu** button is pressed, the message “WAIT RESET” appears and the contents of the firmware remain old.
- If the **Enter** button is pressed, the rewriting job continues, but soon stops again with the error.

- Check Sum Error

The program has failed to write to the DIMM and complete the job without abandoning data. In this case, the DIMM updating program does not start at power on and the message “Service-call error C*****” appears.

If the buttons On Line, Alt, and Value are simultaneously pressed twice, the error is cleared and the DIMM updating program starts to rewriting.

4.2.26 Copying the DIMM Module

The firmware can be copied directly from one DIMM module to another.

1. Insert the DIMM containing the old firmware (target) and the one containing the new firmware (muster) to the sockets A and B, respectively.
2. While holding down the buttons On Line, Alt, and Enter on the control panel, turn the printer on. when the messages "ROM Copy Mode", press the Enter button. The printer enters the DIMM copy mode.
3. The message "C***** error" appears and the new firmware has been copied.



Before removing/inserting the DIMM, make sure the printer power is off. Failure to do so may damage the DIMM.



If no DIMM is installed in the socket B, the firmware stored in the DIMM module in the PROG socket is copied.

CHAPTER

5

ADJUSTMENT

This printer requires no adjustment.

CHAPTER

6

MAINTENANCE

6.1 Overview

This chapter contains the information on how to maintain the printer. The printer does not require any lubrication or adhesion but maintenance by users and qualified servicers to keep its function and performance at an optimum level.

6.1.1 Maintenance by Users

The maintenance items performed by users are shown below.

Table 6-1. User-performable Maintenance List

Maintenance item	Perform when:	Method
Cleaning the Image Transfer Roller	The printer shows malfunction.	TBD
Cleaning the Paper Take-up Roller	Paper is fed abnormally.	Wipe the Paper Take-up Roller with a soft cloth moistened with water. (Do not use any other materials, including alcohol.)

NOTE: Do not touch the Image Transfer Roller directly with your hands.

6.1.2 Replacement of Consumable Items

The all consumable items are replaced by the user.

Table 6-2. Replacement of Consumable Item

Replaced item	Replacement cycle	Method
ET Cartridge	Approximately 15,000 sheets	<ol style="list-style-type: none"> 1. Push the open/close cover on the right side of the printer body and open the right cover. 2. Holding the handle on the ET Cartridge, pull the ET cartridge out of the printer. 3. Get a new ET Cartridge and shake it right and left and back and forth. 4. Insert the new ET Cartridge into the printer body securely. 5. Close the right cover on the printer.

6.1.3 Maintenance by Servicers

The units listed in the following table are replaced by the servicers.

Table 6-3. Maintenance by Servicers

Replaced item	Replacement cycle
Fusing Unit	500,000 sheets
Image Transfer Roller Unit	150,000 sheets
Paper Take-Up Roller	120,000 sheets

NOTE: Figures are applicable under the conditions below:
Duty: 5%, A4 LEF, Continuous printing



- After replacing the Fusing Unit, perform “Fuser Counter Clear” in the maintenance mode. (See Chapter 1 / Section 1.4.5.)
- After replacing the Image Transfer Unit, perform “TR Counter Clear” in the maintenance mode. (See Chapter 1 / Section 1.4.5.)
- After replacing the Paper Take-up Roller, perform “MP Counter Clear” and “LC1 Counter Clear” in the maintenance mode. (See Chapter 1 / Section 1.4.5.)



The grease type used for the Drive Section is MOLYCORT EM-50L. (Do not apply to the Fusing Unit.)

CHAPTER

7

APPENDIX

7.1 Connector Summary

Table 7-1. Connector Summary - C269MAIN Circuit Board (PWB-P)

Connector number	Number of pins	Constituent to which the connector is connected	Constituent to which the other end of the harness is connected
CN1	36	IEEE-1284 parallel interface	-
CN2	25	RS-232C serial interface	-
CN3	26	Control panel	-
CN4	32	Video interface	PWB-A PJ1
CN5	20	Type-B interface	-
CN7	50	(IDE hard disc)	-
CN8	168	SDRAM DIMM	-
CN9	-	SCSI (Not used. Reserved for board development.)	-
CN10	-	CPU bus (Not used. Reserved for board development.)	-
CN11	72	ROM DIMM0 A socket	-
CN12	72	ROM DIMM1 B socket	-
CN13	72	ROM DIMM2 C socket	-
CN14	72	CODE DIMM PROG socket	-
CN15, C16	-	Not used. Reserved for board development.	-

Table 7-2. Connector Summary - Engine Controller Board (PWB-A)

Connector number	Number of pins	Constituent to which the connector is connected	Constituent to which the other end of the harness is connected
PJ1	32	Video interface	PWB-P CN4
PJ2	4	Low voltage power supply	PU1 PJ5
PJ3	13	2nd cassette and option cassette control	2nd cassette control board PJ1
PJ4	20	Option interface	Duplex unit
PJ5	9	Option interface	5-bin unit
PJ6	2	Power supply for the power supply unit cooling fan	Power supply unit cooling fan
PJ7	3	Right door interlock switch	-
PJ8	5	Polygon motor control	Printhead unit
PJ9	6	Video signal	Printhead unit
PJ10	2	Low voltage power supply	PU1 PJ5
PJ11	-	Not used	-
PJ12	7	Option interface	10-bin unit
PJ13	26	Sensors	-
PJ14	28	Sensors	High voltage uni, others
PJ15	-	Not used	-
PJ16	12	Motor control, Fuser unit temperature control	Transport motor, I/C drive motor, Fuser lamp thermistor, PU1, PJ4
PJ17, PJ18, PJ19, PJ21	-	Not used	-

Table 7-3. Connector Summary - High Voltage Unit

Connector number	Number of pins	Constituent to which the connector is connected	Constituent to which the other end of the harness is connected
CN1	4	High voltage unit control	PWB-A PJ14
CN9	6	Low voltage power supply	PU1 PJ5

Table 7-4. Connector Summary - Low Voltage Unit

Connector number	Number of pins	Constituent to which the connector is connected	Constituent to which the other end of the harness is connected
PJ1	3	Power switch	-
PJ2	2	10-bin unit power supply	-
PJ4	5	Fuser unit temperature control	PWB-A JP10
ST3, 4	-	Heater lamp power supply	-

7.2 Component Layout

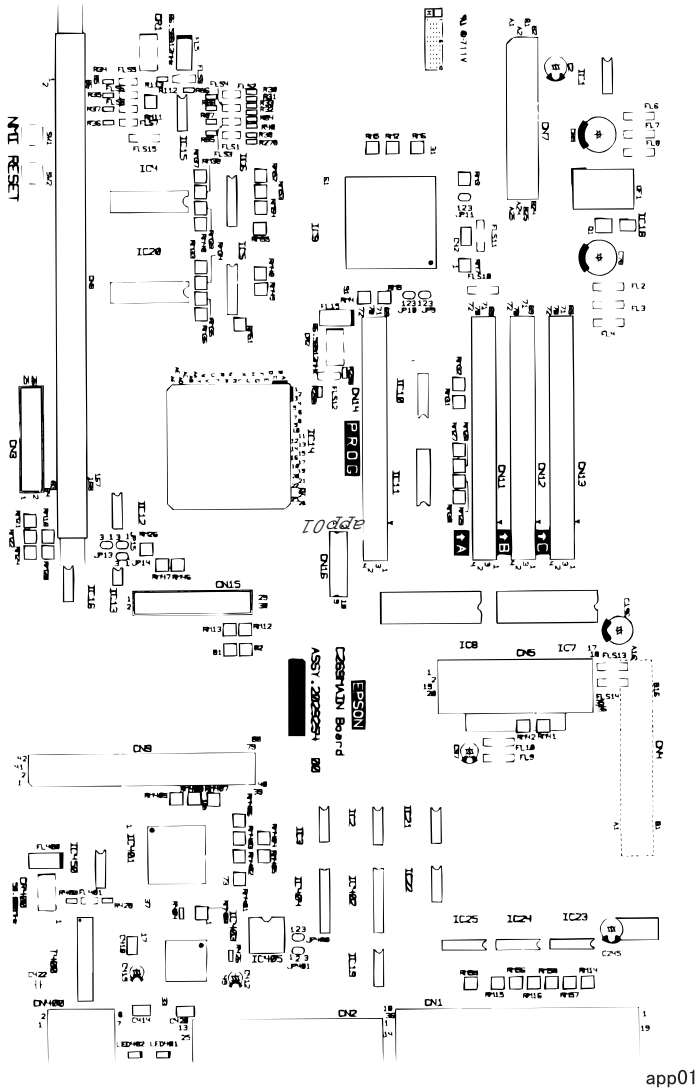

Figure 7-1.
Component Layout - C269MAIN Board (component side)



Figure 7-2.
Component Layout - C269MAIN Board (Soldered side)

7.3 Exploded Diagrams

7.3.1 Housing

Table 7-5. Parts List - Housing

Ref. No.	Part Name
1	COVER
2	COVER
3	TOP COVER
4	SEAL
5	COVER
6	COVER
7	COVER
8	REAR COVER
9	COVER
10	SEAL
11	RAIL
12	HANDLE
13	FRONT COVER
14	COVER

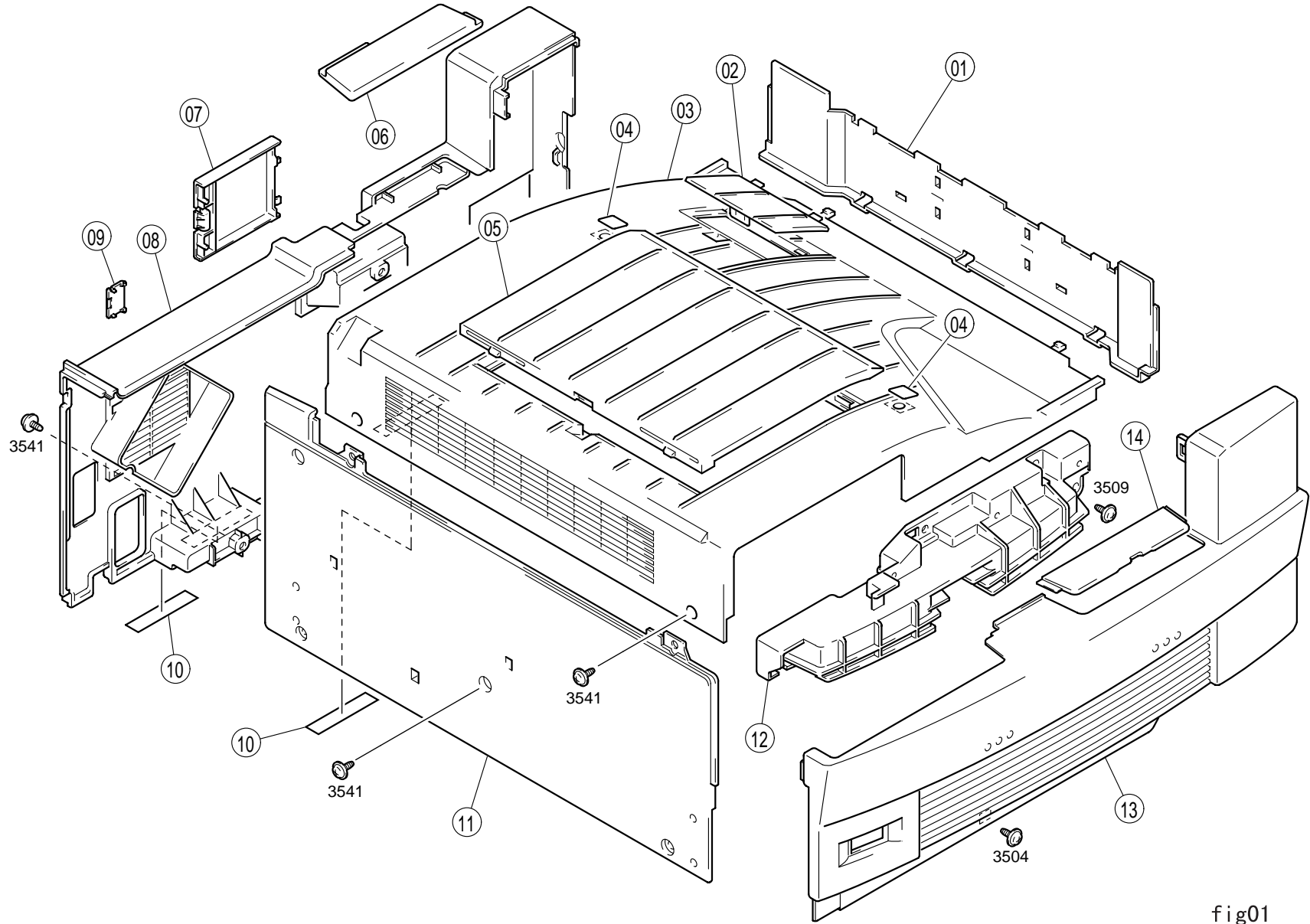

fig01

7.3.2 Frames

Table 7-6. Parts List - Frames

Ref. No.	Part Name	Ref. No.	Part Name
1	LABEL	20	FRAME
2	LABEL	21	RUBBER FOOT
3	I/C GUIDE ASSY	22	HOLDER
4	PLATE SPRING	23	COLLAR
5	FRAME	24	BRACKET
6	TENSION SPRING	25	HARNESS
7	LEVER	26	SWITCH
8	TENSION SPRING	27	HARNESS
9	FLANGE	28	GUIDE PLATE
10	PRESSURE SPRING	29	LABEL HIGH VOLTAGE
11	RUBBER FOOT	30	BRACKET
12	FLANGE	31	TENSION SPRING
13	COVER	32	RETAINING RING
14	WIRE	33	LEVER
15	GUIDE	34	SHAFT
16	PLATE SPRING	35	JOINT
17	SHUTTER	36	LEVER
18	TORSION SPRING	37	GUIDE
19	BASE FRAME	-	-

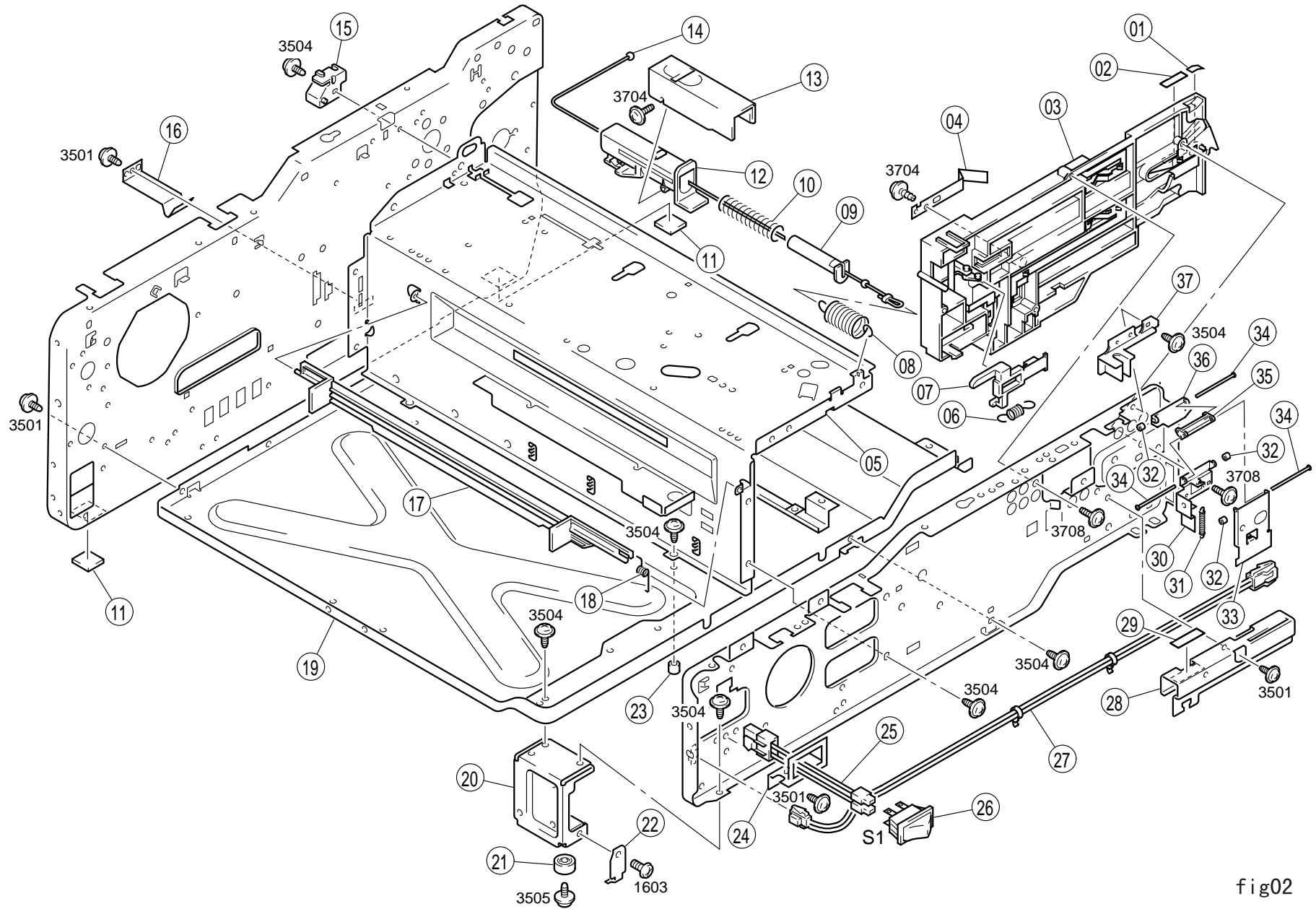

fig02

7.3.3 Fusing Section (A)

Table 7-7. Parts List - Fusing Section (A)

Ref. No.	Part Name	Ref. No.	Part Name	Ref. No.	Part Name
1	COVER	19	SHOULDER SCREW	37	GUIDE PLATE-FNT
2	COVER	20	LEVER	38	REINFORCE PLATE
3	LABEL CAUTION - HOT	21	TORSION SPRING	39	SPACER
4	STOPPER	22	COVER	40	FRONT FRAME
5	COVER	23	REAR FRAME	41	SHOULDER SCREW
6	SPACER	24	SHOULDER SCREW	42	COVER
7	GUIDE ASSY	25	GEAR 17T	43	TORSION SPRING
8	SPACER	26	GEAR 22T	44	LABEL JAM REMOVAL
9	STOPPER	27	LEVER	45	TORSION SPRING
10	PHOTO INTERRUPTER, EXIT (PC3)	28	TENSION SPRING	46	SEAL
11	GUIDE LEVER	29	GEAR 24T	47	FRAME ASSY
12	ROLL	30	GEAR 14T	48	SHAFT
13	TORSION SPRING	31	BUSHING	49	REINFORCE PLATE
14	ACTUATOR	32	HOLDER	50	LEVER
15	GUIDE LEVER	33	SPACER	51	STOPPER
16	GUIDE LEVER	34	GUIDE	52	NEUTRALIZING BRUSH
17	HARNESS	35	ROLLER	53	SPACER
18	SHAFT	36	SPACER	54	FUSING UNIT

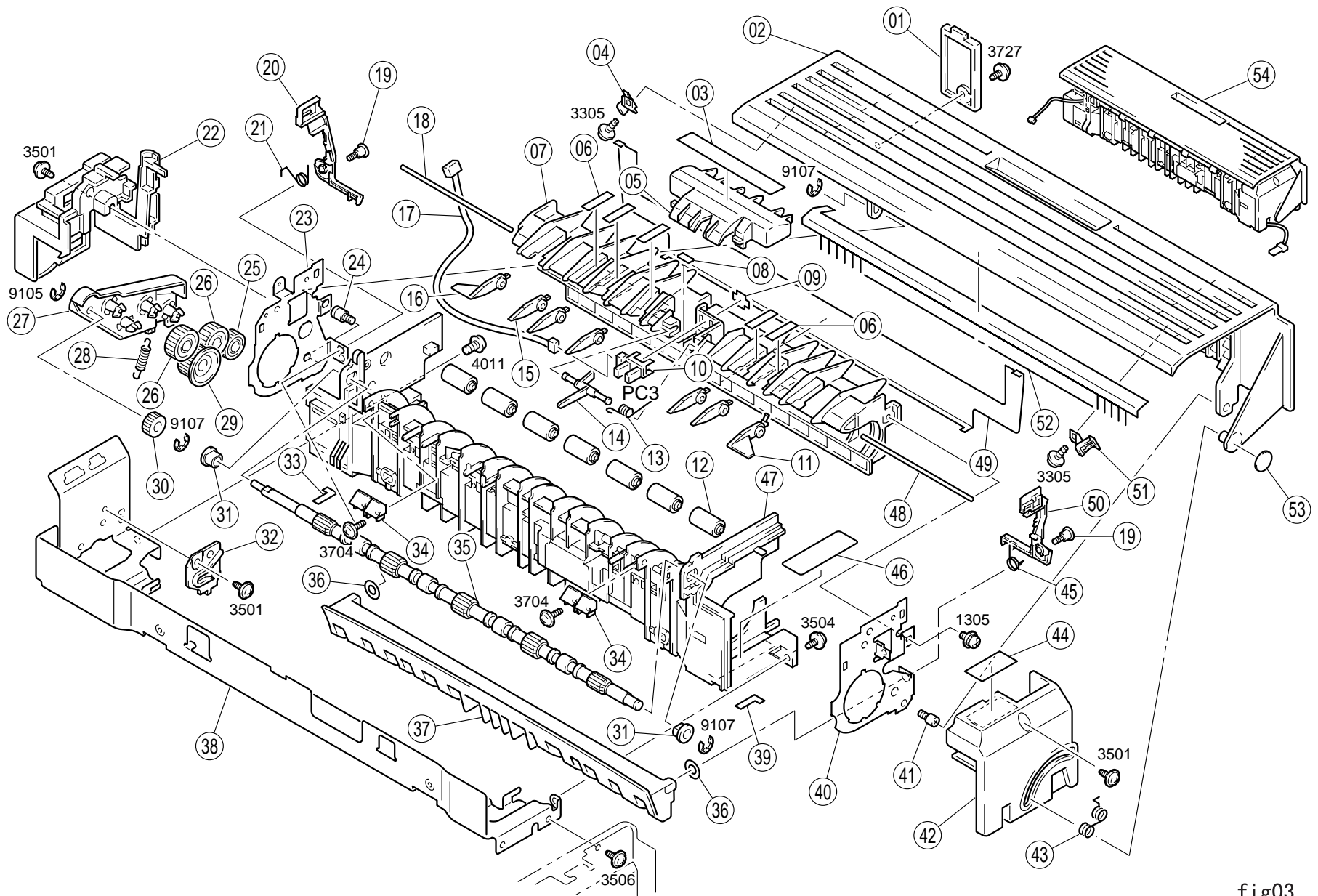

fig03

7.3.4 Fusing Section (B)

Table 7-8. Parts List - Fusing Section (B)

Ref. No.	Part Name	Ref. No.	Part Name
1	SHOULDER SCREW	21	TUBE
2	COLLAR	22	ROLL
3	PRESSURE SPRING	23	TUBE
4	SPACER	24	TUBE
5	BALL BEARING	25	TORSION SPRING
6	LEVER	26	SHAFT
7	GEAR 20T	27	THERMOSTAT, FUSING (TS1)
8	GEAR 20T	28	THERMAL FUSE
9	SHAFT	29	SUPPORT PLATE
10	REGULATING PLATE	30	GROUND PLATE
11	PW BOARD-R (NO IC) (PWB-R)	31	HOLDER
12	C-RING	32	HARNESS
13	GEAR 39T	33	SEPARATOR
14	BUSHING	34	FUSING ROLLER
15	THERMISTOR, FUSING (TH1)	35	COLLAR
16	PRESSURE SPRING	36	HEATER
17	ROLL	37	REGULATING PLATE
18	HOLDER	38	SHAFT
19	HOLDER	39	LAVER
20	HOLDER	40	ROLLER

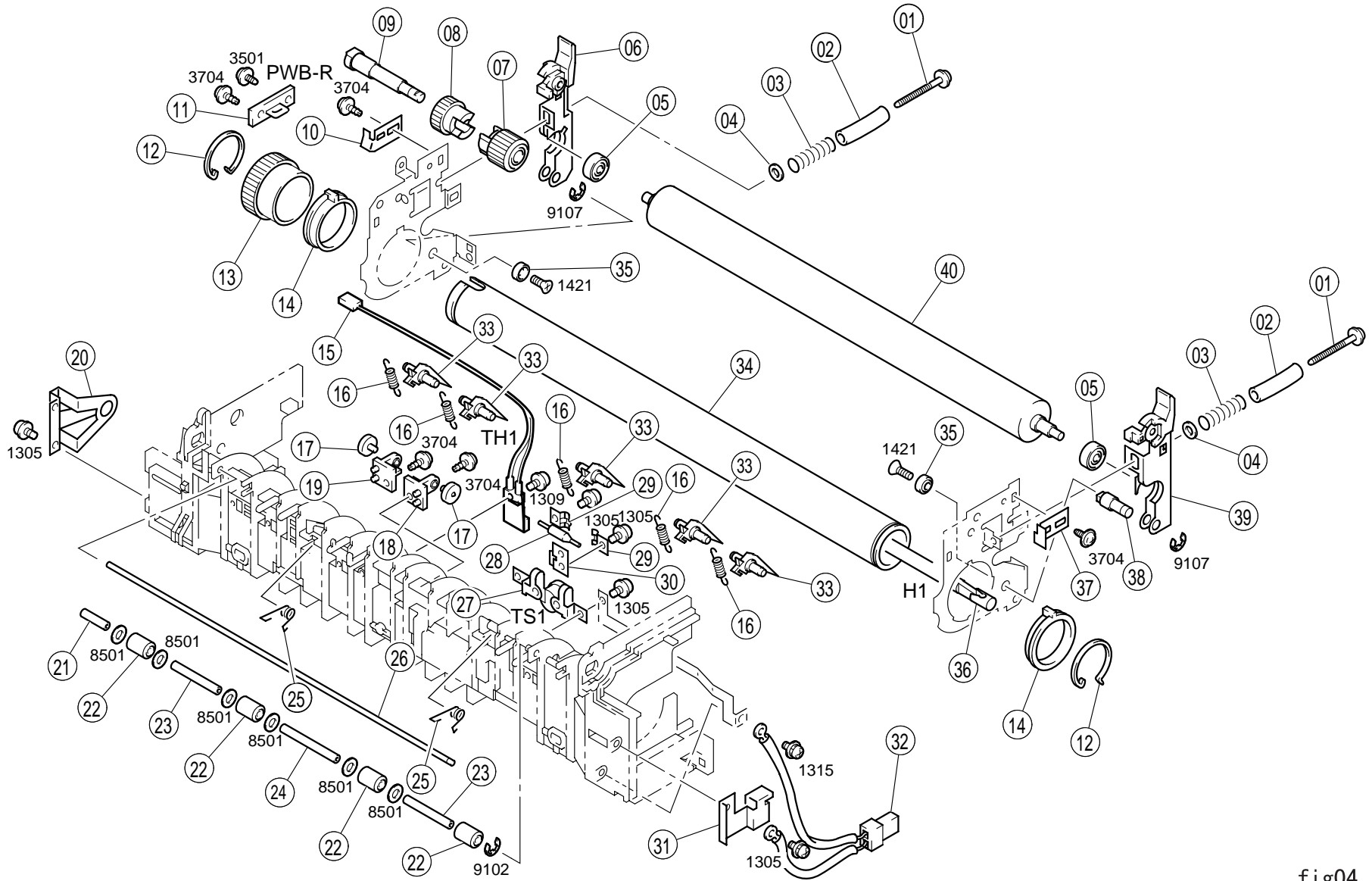

fig04

7.3.5 Transport Section (A)

Table 7-9. Parts List - Transport Section (A)

Ref. No.	Part Name	Ref. No.	Part Name	Ref. No.	Part Name
1	SCALE	17	TORSION SPRING	33	SHOULDER SCREW
2	REGULATING PLATE	18	HOOK	34	BRACKET
3	REGULATING PLATE	19	PRESSURE SPRING	35	HOOK
4	TABLE	20	GROUND PLATTE	36	LOCK RELEASE LEVER
5	COVER	21	BRACKET	37	COVER
6	COVER	22	HARNESS	38	LEVER
7	STOPPER	23	WASHER	39	COVER
8	PRESSURE SPRING	24	FAN MOTOR, COOLING (M3)	40	ROLLER
9	LEVER ASSY	25	CUSHION	41	GUIDE
10	COVER	26	SHAFT	42	BUSHING
11	CLUTCH, MAN FEED (CL3)	27	JOINT	43	GUIDE BAR
12	HARNESS	28	GEAR 14T	44	ROLL
13	GROUND PLATE	29	LEVER	45	PHOTO INTERRUPTER, MAN FEED (PC8)
14	COVER	30	LEVER	46	ACTUATOR
15	LOCK PLATE	31	GEAR 14T	47	GEAR 12T
16	COVER	32	SHOULDER SCREW	48	LABEL

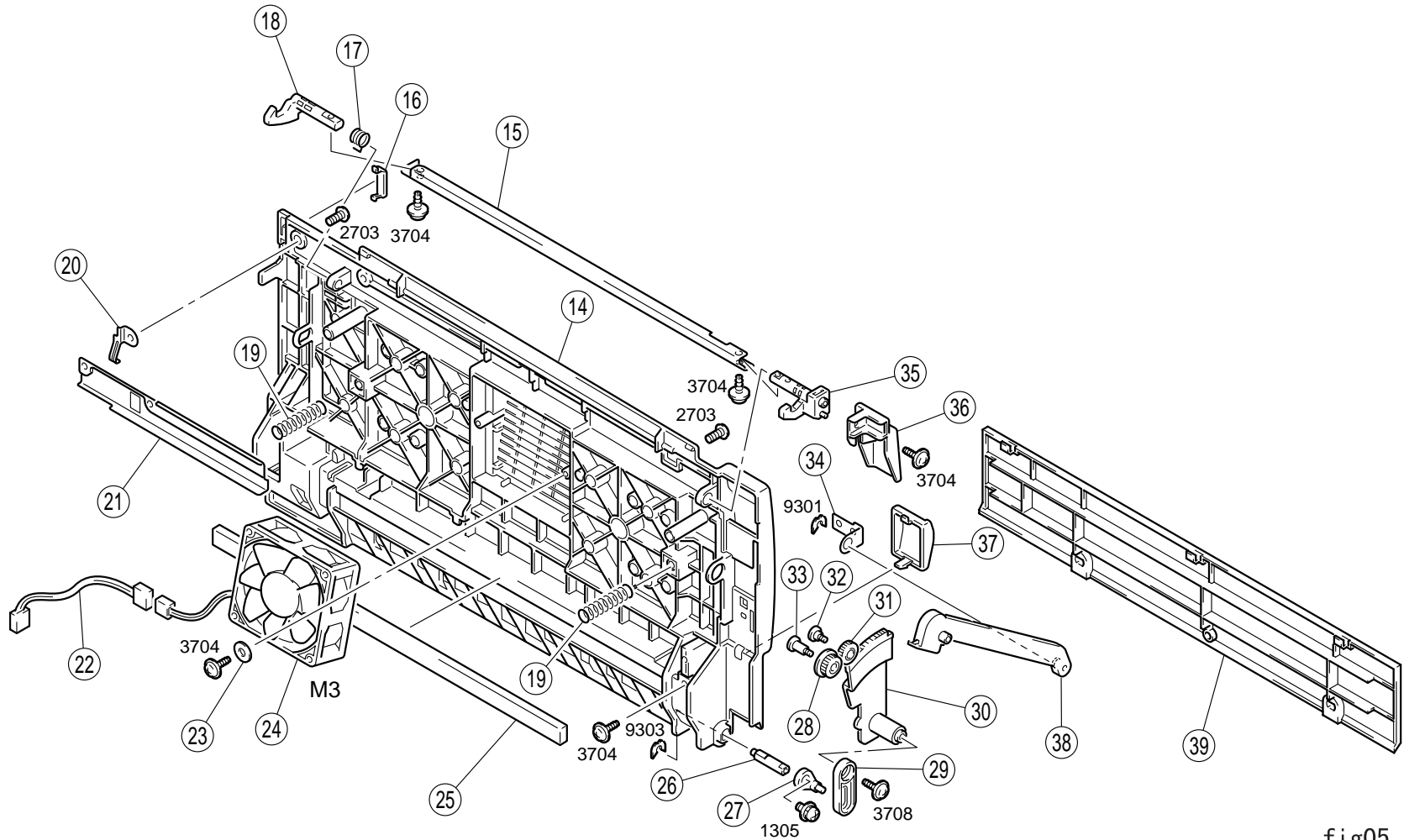

fig05

7.3.6 Transport Section (B)

Table 7-10. Parts List - Transport Section (B)

Ref. No.	Part Name	Ref. No.	Part Name
1	TERMINAL	15	ACTUATOR
2	BRACKET	16	TRANSFER ROLLER UNIT
3	HOLDER ASSY	17	CONVEYOR ROLLER
4	PW BOARD-R (PWB-R)	18	CONVEYOR ROLLER
5	PRESSURE SPRING	19	POLYESTER FILM
6	PLATE SPRING	20	GUIDE BAR
7	BUSHING	21	GROUND PLATE
8	TENSION SPRING	22	GEAR 13T
9	BUSHING	23	GEAR 18T
10	CLUTCH	24	TERMINAL
11	HARNESS, TIMING (CL1)	25	GROUND PLATE
12	PRESSURE SPRING	26	GEAR 18T
13	TORSION SPRING	27	TRANSPORT UNIT
14	PHOTO INTERRUPTER, TIMING (PC2)	-	-

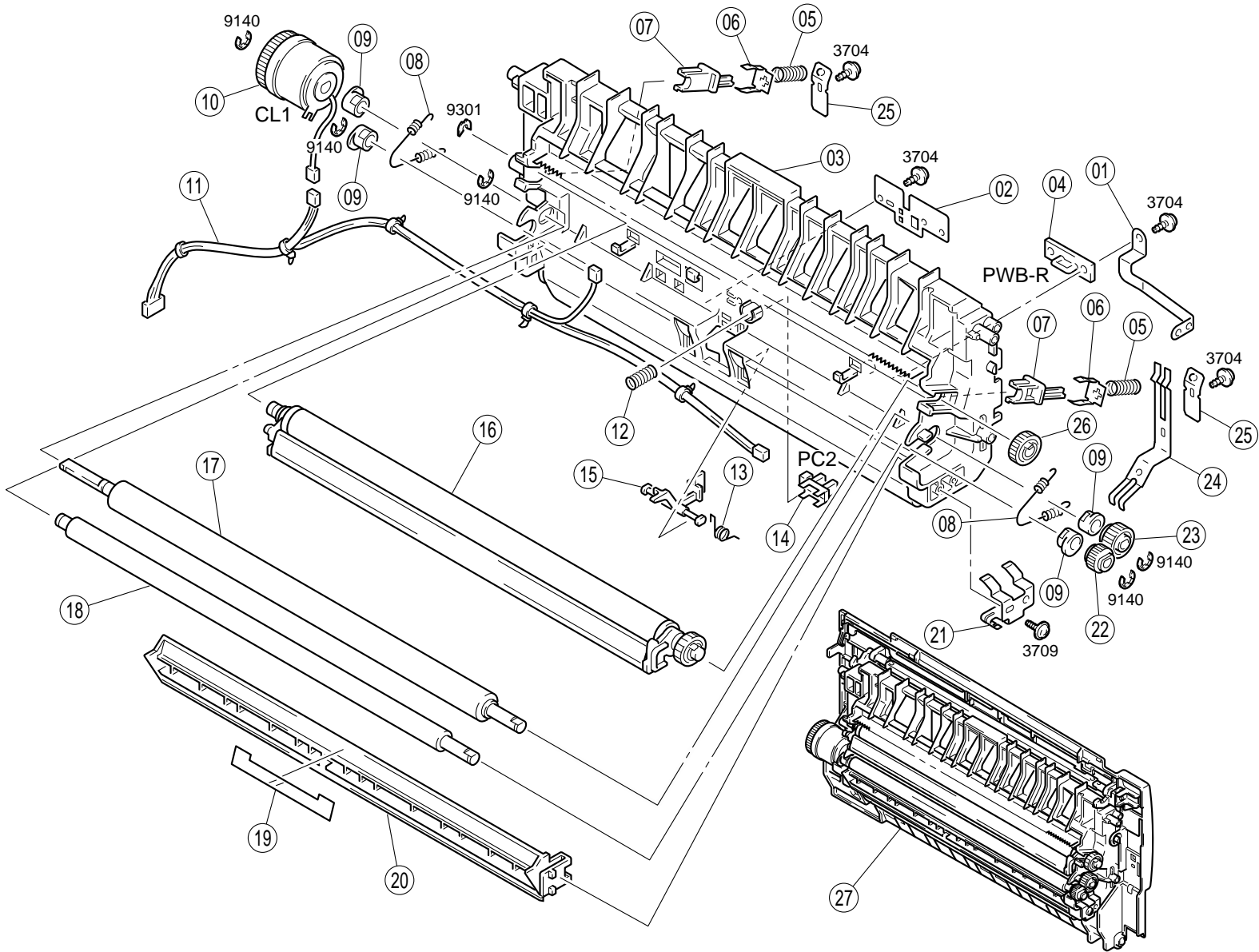

fig06

7.3.7 Electrical Components

Table 7-11. Parts List - Electric Components

Ref. No.	Part Name	Ref. No.	Part Name
1	COVER	12	PWB SUPPORT
2	COVER	13	BRACKET
3	REINFORCE PLATE	14	IC
4	LABE CAUTION	15	FUSE 3A
5	FUSE 3.15A (F3)	16	PW BOARD-A, MAIN (PWB-A)
6	FUSE 15A/8A (F2)	17	PW BOARD-P, CONT (PWB-P)
7	BRACKET	18	GUIDE RAIL
8	FUSE 10A/6.3A (F1)	19	GUIDE PLATE
9	POWER SUPPLY (PU1)	20	BRACKET
10	P/H ASSY	21	COVER
11	PWB SUPPORT 6.4H	22	SCREW

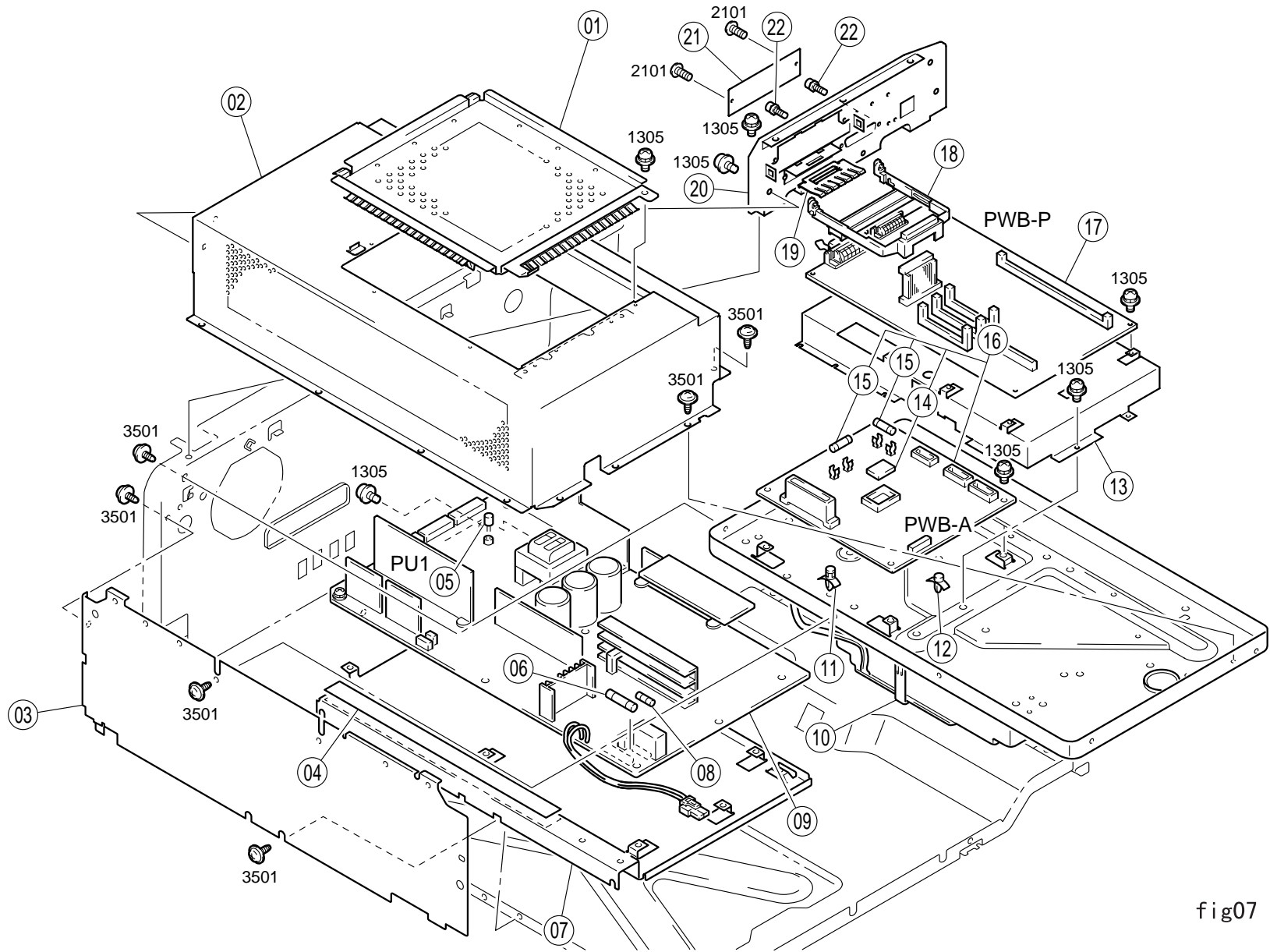

fig07

7.3.8 Paper Take-up Section

Table 7-12. Parts List - Paper Take-up Section

Ref. No.	Part Name	Ref. No.	Part Name
1	HARNESS	13	ACTUATOR
2	GUIDE BAR	14	PWB-HV (HV1)
3	SPONGE	15	LABEL HIGH VOLTAGE
4	POLYESTER FILM	16	COVER ASSY
5	RAIL	17	RAIL
6	GROUND PLATE	18	RUBBER FOOT
7	BRACKET	19	HOLDER
8	HARNESS	20	BRACKET
9	PW BOARD-G, EMPTY (PWB-G)	21	LEVER
10	COVER	22	TERMINAL
11	SHOULDER SCREW	23	COVER
12	PHOTO INTERRUPTER, EMPTY (PC4)	-	-

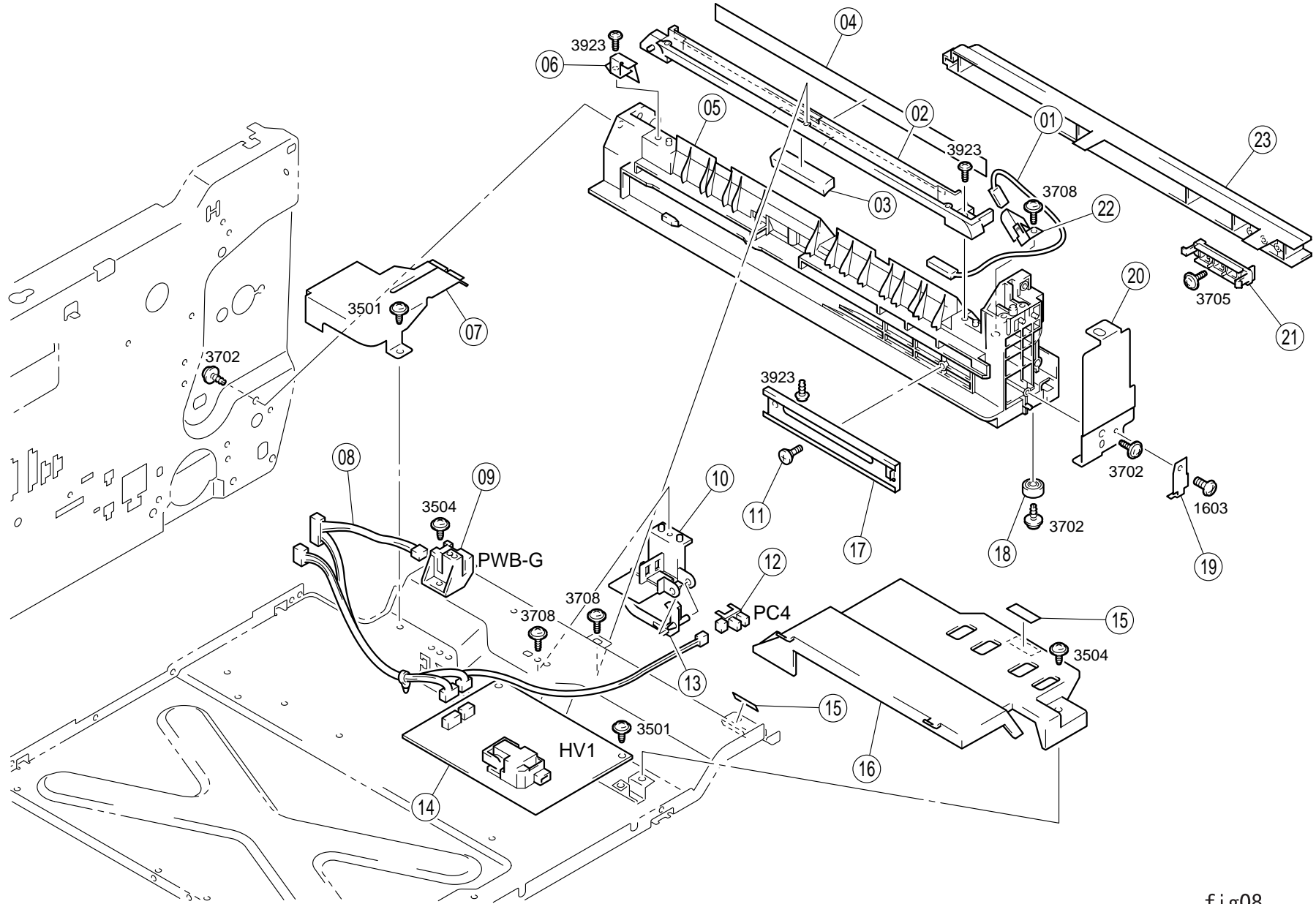

fig08

7.3.9 Drive Section

Table 7-13. Parts List - Drive Section

Ref. No.	Part Name	Ref. No.	Part Name
1	GUIDE	20	HARNESS
2	TORSION SPRING	21	BUSHING
3	BRACKET	22	BRACKET
4	MICRO SWITCH, DOOR SIDE (S2)	23	HARNESS
5	PW BOARD - I, SIZE (PWB-I)	24	GEAR 49T
6	HOLDER	25	COVER
7	PWB-MOTOR, TRANS (M2)	26	BRACKET
8	PWB-MOTOR, I/C (M1)	27	LEVER
9	LEVER	28	PHOTO INTERRUPTER, NEAR EMP (PC5)
10	POWER CODE	29	HARNESS
11	FAN MOTOR, COOLING (M4)	30	DRIVE UNIT
12	BRACKET	31	LABEL
13	DETECTING SWITCH, SIZE (S3)	32	GEAR 20T
14	HARNESS	33	GEAR 18T
15	COVER	34	SHAFT
16	BRACKET	35	SHAFT
17	HOLDER	36	BRACKET
18	BRACKET	37	HARNESS
19	FERRITE CORE	38	COVER

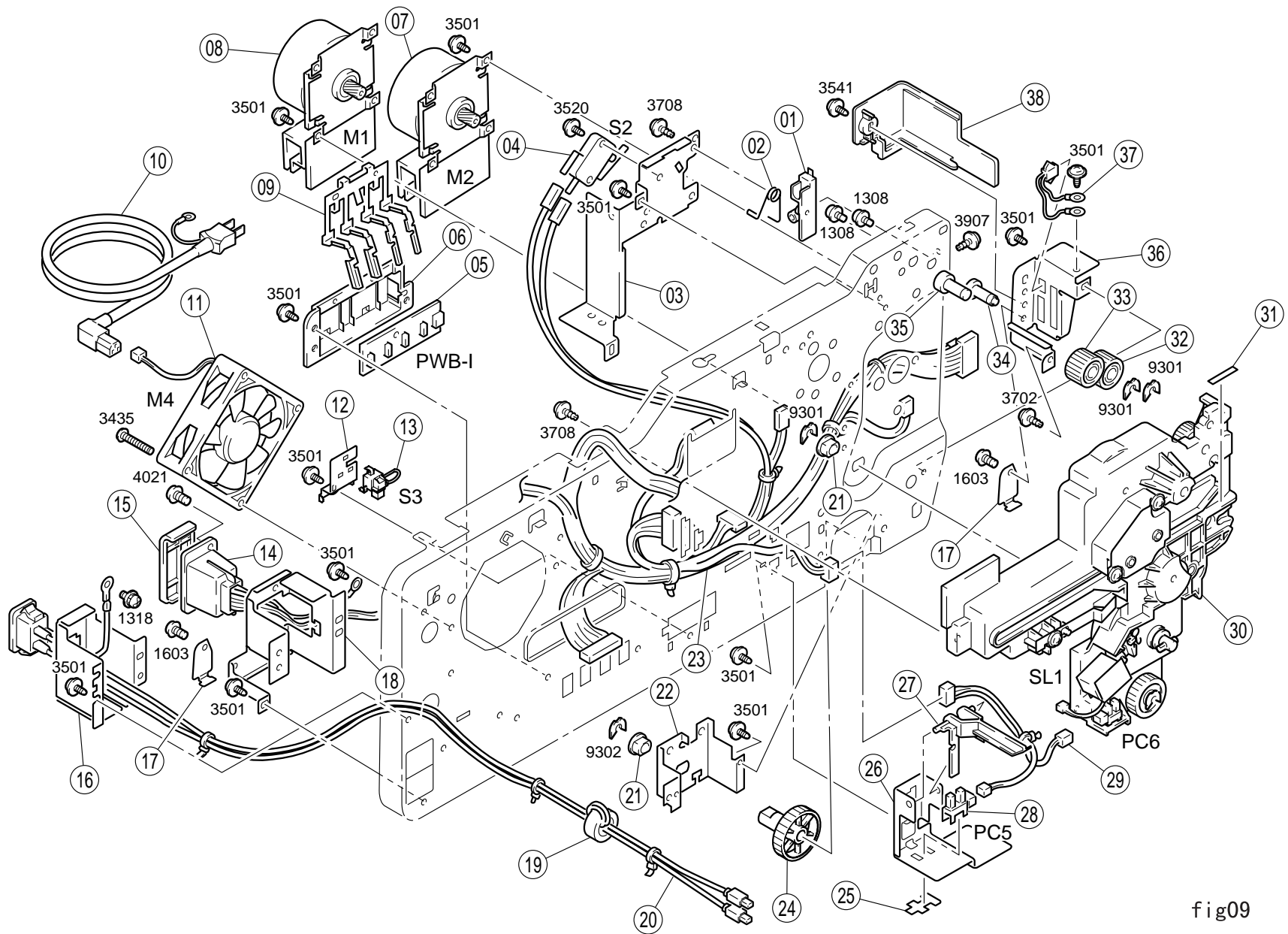
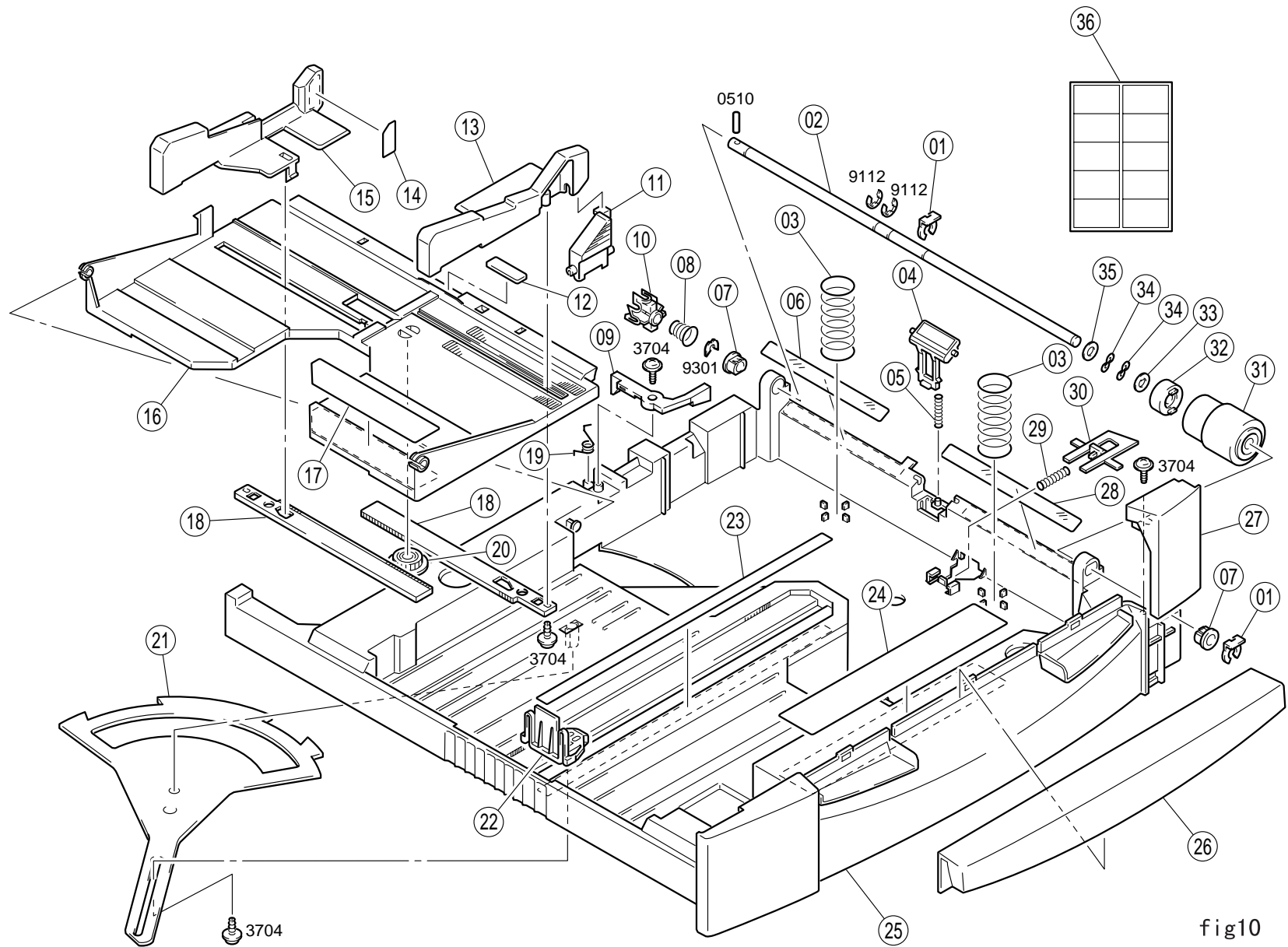

fig09

7.3.10 Paper Tray Unit

Table 7-14. Parts List - Paper Tray Unit

Ref. No.	Part Name	Ref. No.	Part Name
1	STOPPER RING	19	TORSION SPRING
2	SHAFT	20	GEAR 20T
3	PRESSURE SPRING	21	LEVER
4	SEPARATOR	22	REGULATING PLATE
5	PRESSURE SPRING	23	LENGTH SCALE
6	POLYESTER FILM	24	LABEL PAPER LOADING
7	BUSHING	25	CASSETTE BODY
8	PRESSURE SPRING	26	HANDLE
9	LEVER	27	COVER
10	JOINT	28	POLYESTER FILM
11	LOCK LEVER	29	PRESSURE SPRING
12	FRICTION SHEET	30	LOCK LEVER
13	REGULATING PLATE	31	ROLL
14	LABE MAX LEVEL	32	WEIGHT
15	REGULATING PLATE	33	WASHER
16	LIFTING PLATE	34	WAVE WASHER
17	WIDTH SCALE	35	WASHER
18	RACK GEAR	36	LABE PAPER SIZE



7.4 Circuit Diagrams

See the following pages for the circuit diagrams for C269MAIN Board.

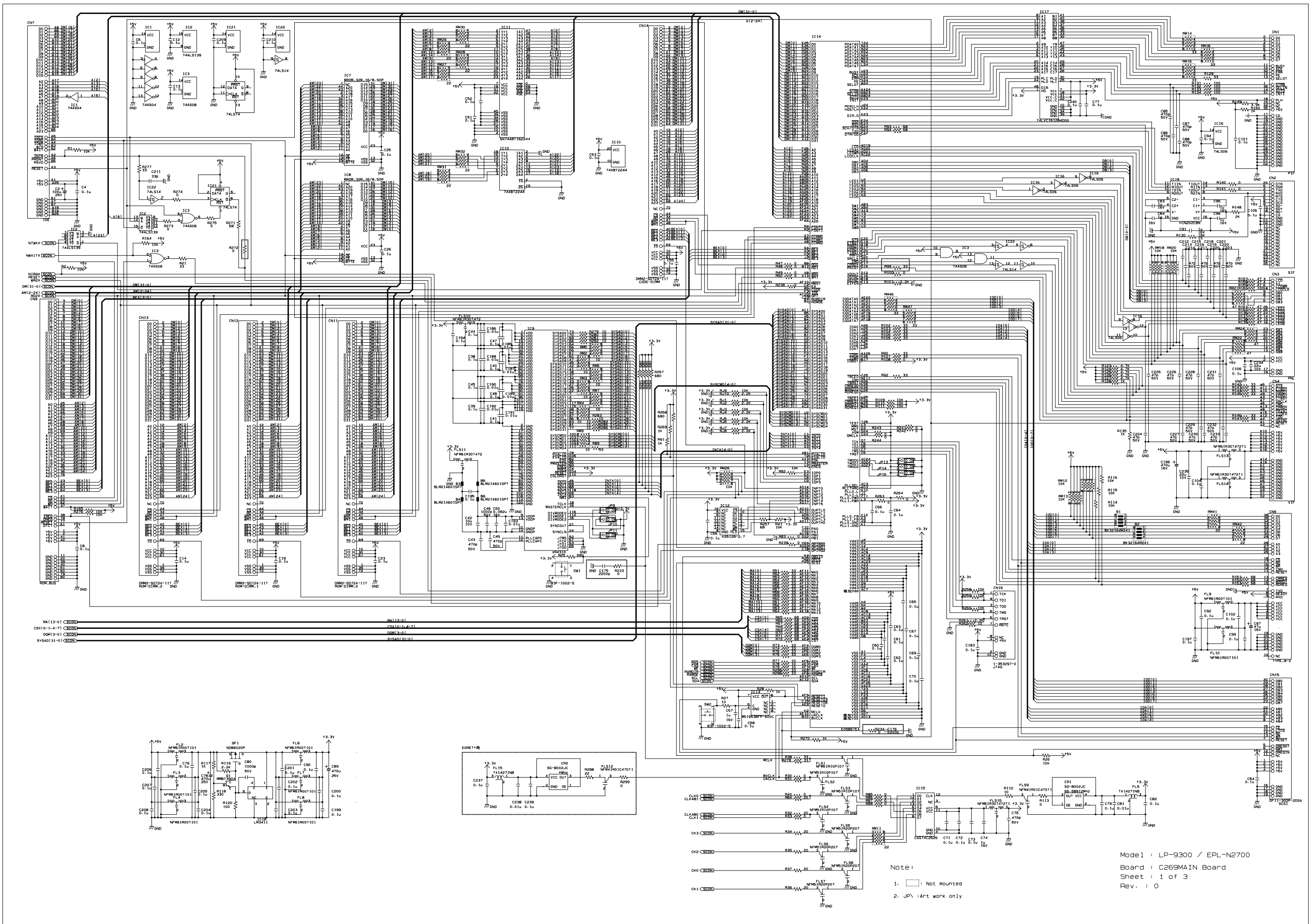

Note:
 1. □: Not mounted
 2. JP: Art work only

Model : LP-9300 / EPL-N2700
 Board : C269MAIN Board
 Sheet : 1 of 3
 Rev. : 0

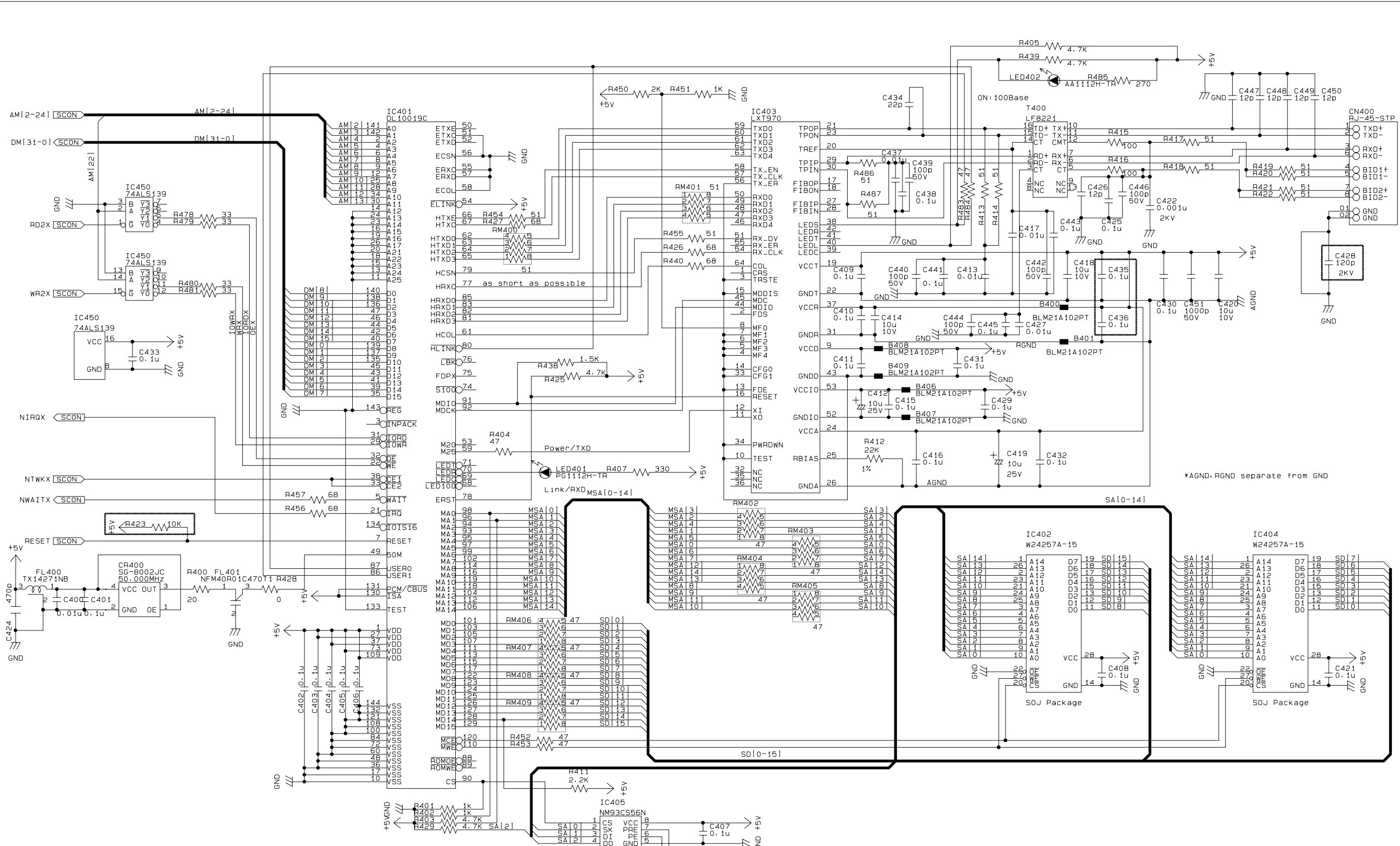

Model : LP-9300 / EPL-N2700
 Board : C269MAIN Board
 Sheet : 2 of 3
 Rev. : 0

JP400: Protect Register Enable
 1-2: Normal Access
 2-3: Protect Register Access
 JP401: Program Enable
 1-2: Program Disable(Protect)
 2-3: Program Enable

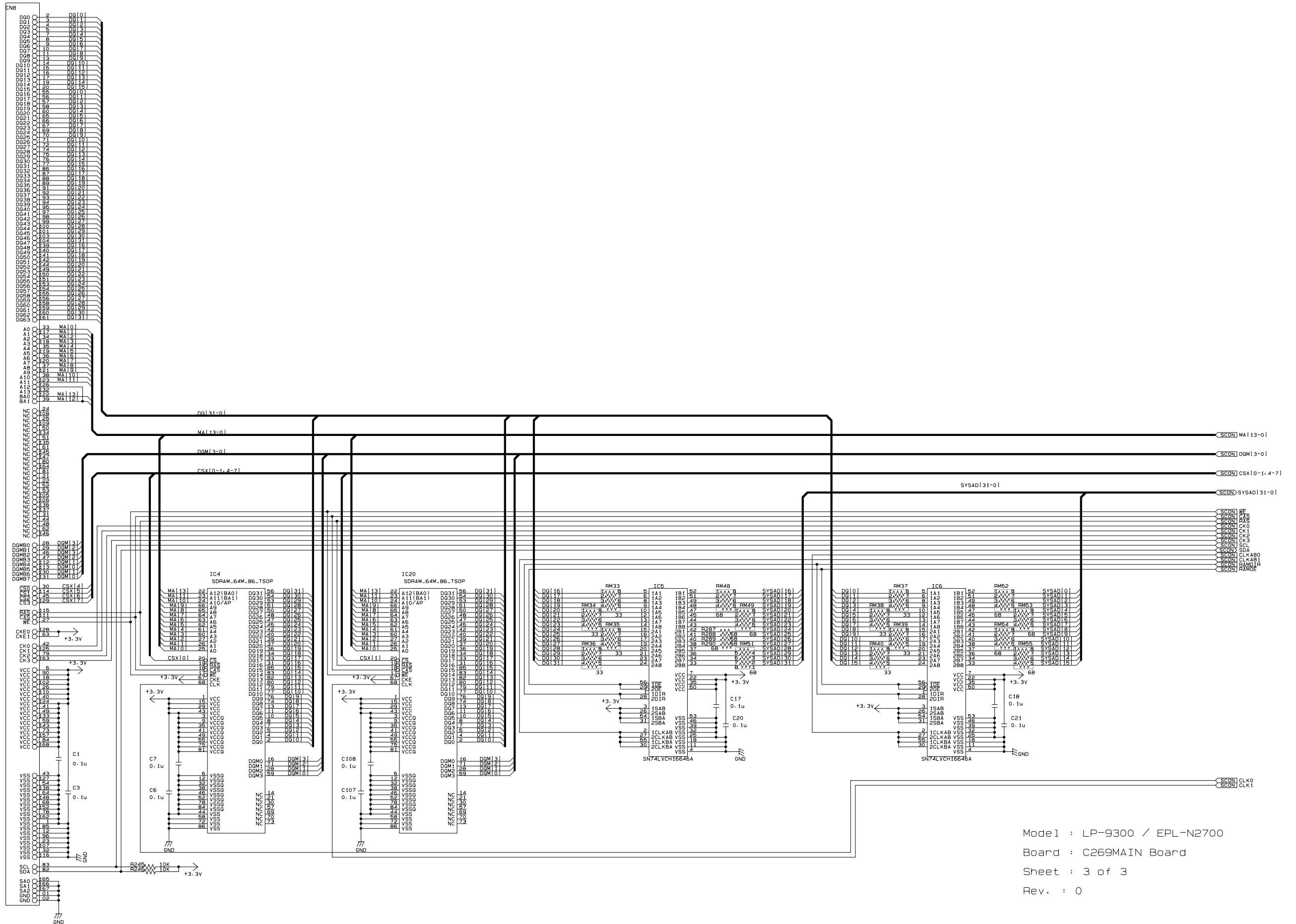

Mode1 : LP-9300 / EPL-N2700
 Board : C269MAIN Board
 Sheet : 3 of 3
 Rev. : 0

Free Manuals Download Website

<http://myh66.com>

<http://usermanuals.us>

<http://www.somanuals.com>

<http://www.4manuals.cc>

<http://www.manual-lib.com>

<http://www.404manual.com>

<http://www.luxmanual.com>

<http://aubethermostatmanual.com>

Golf course search by state

<http://golfingnear.com>

Email search by domain

<http://emailbydomain.com>

Auto manuals search

<http://auto.somanuals.com>

TV manuals search

<http://tv.somanuals.com>