

Cooker with electric ventilated oven and ceramic hob

Instructions for installation and use
K3C36/G



GB **Cooker with electric ventilated oven and ceramic hob**

Instructions for installation and use

Important safety warnings

To maintain the EFFICIENCY and SAFETY of this appliance, we recommend:

- call only the Service Centers authorized by the manufacturer
- always use original Spare Parts

- 1 This appliance is intended for nonprofessional use within the home.
- 2 These instructions are only for those countries whose symbols appear in the booklet and on the serial no. plate of the appliance.
- 3 **This owner's manual is for a class 1 appliance (insulated) or class 2, subclass 1 appliances (installed between two cabinets).**
- 4 Before using your appliance, read the instructions in this owner's manual carefully since it provides all the information you need to ensure safe installation, use and maintenance. Always keep this owner's manual close to hand since you may need to refer to it in the future.
- 5 When you have removed the packing, check that the appliance is not damaged. If you have any doubts, do not use the appliance and contact your nearest Ariston Service Centre. Never leave the packing components (plastic bags, polystyrene foam, nails, etc.) within the reach of children since they are a source of potential danger.
- 6 The appliance must be installed only by a qualified technician in compliance with the instructions provided. The manufacturer declines all liability for improper installation, which may result in personal injury and damage to property.
- 7 The electrical safety of this appliance can only be guaranteed if it is correctly and efficiently earthed, in compliance with regulations on electrical safety. Always ensure that the earthing is efficient. If you have any doubts, contact a qualified technician to check the system. The manufacturer declines all liability for damage resulting from a system which has not been earthed.
- 8 Before plugging the appliance into the mains, check that the specifications indicated on the date plate (on the appliance and/or packaging) correspond with those of the electrical and gas systems in your home.
- 9 Check that the electrical capacity of the system and sockets will support the maximum power of the appliance, as indicated on the data plate. If you have any doubts, contact a qualified technician.
- 10 An omnipolar switch with a contact opening of at least 3 mm or more is required for installation.
- 11 If the socket and appliance plug are not compatible, have the socket replaced with a suitable model by a qualified technician, who should also check that the cross-section of the socket cable is sufficient for the power absorbed by the appliance. The use of adaptors, multiple sockets and/or extensions, is not recommended. If their use cannot be avoided, remember to use only single or multiple adaptors and extensions which comply with current safety regulations. In these cases, never exceed the maximum current capacity indicated on the individual adaptor or extension and the maximum power indicated on the multiple adapter.
- 12 Do not leave the appliance plugged in if it is not in use. Switch off the main switch and gas supply when you are not using the appliance.
- 13 The openings and slots used for ventilation and heat dispersion must never be covered.
- 14 The user must not replace the supply cable of this appliance. Always contact an after-sales service centre which has been authorised by the manufacturer if the cable has been damaged or needs replacement.
- 15 This appliance must be used for the purpose for which it was expressly designed. Any other use (e.g. heating rooms) is considered to be improper and consequently dangerous. The manufacturer declines all liability for damage resulting from improper and irresponsible use.
- 16 A number of fundamental rules must be followed when using electrical appliances. The following are of particular importance:
 - Do not touch the appliance when your hands or feet are wet.
 - Do not use the appliance barefooted.
 - Do not use extensions, but if they are necessary, caution must be exercised.
 - Never pull the power supply cable or the appliance to unplug the appliance plug from the mains.
 - Never leave the appliance exposed to atmospheric agents (rain, sun etc.)
 - Do not allow children or persons who are not familiar with the appliance to use it, without supervision.
- 17 Always unplug the appliance from the mains or switch off the main switch before cleaning or carrying out maintenance.
- 18 If you are no longer using an appliance of this type, remember to make it unserviceable by unplugging the appliance from the mains and cutting the supply cable. Also make all potentially dangerous parts of the appliance safe, above all for children who could play with the appliance.
- 19 To avoid accidental spillage do not use cookware with uneven or deformed bottoms on the electric plates. Turn the handles of pots and pans inwards to avoid knocking them over accidentally.
- 20 Never use flammable liquids such as alcohol or gasoline, etc. near the appliance when it is in use.
- 21 When using small electric appliances near the hob, keep the supply cord away from the hot parts.
- 22 Make sure the knobs are in the "●"/"○" position when the appliance is not in use.
- 23 When the appliance is in use, the heating elements and some parts of the oven door become extremely hot. Make sure you don't touch them and keep children well away.
- 24 If the cooker is placed on a pedestal, take the necessary precautions to prevent the same from sliding off the pedestal itself.

Installation

The following instructions should be read by a qualified technician to ensure that the appliance is installed, regulated and technically serviced correctly in compliance with current regulations.

Important: disconnect the cooker from the electricity when making any adjustment, maintenance operation, etc.

Positioning

The appliance can be installed next to furniture units which are no taller than the top of the cooker hob. For proper installation of the cooker, the following precautions must be taken:

- Kitchen cabinets installed next to the cooker that are taller than the top of the hob must be situated at least 200 mm from the edge of the hob.
- Hoods must be installed according to the requirements in the installation manual for the hoods themselves and in any case at a minimum distance of 650 mm.
- Place the wall cabinets adjacent to the hood at a minimum height of 420 mm from the hob (see figure).
- Should the cooker be installed beneath a wall cabinet, the latter should be situated at least 700 mm (millimetres) away from the hob, as shown in the figure.
- the cut-out for the cooker cabinet should have the dimensions indicated in the figure.

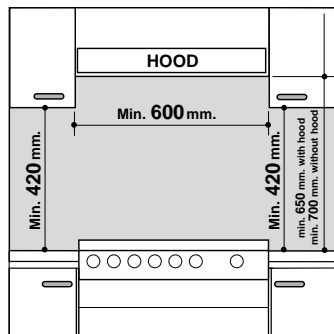

Levelling your appliance (only on a few models)

Your cooker is supplied with feet for levelling the appliance. If necessary, these feet can be screwed into the housings in the corners of the cooker base (Fig. A).

Mounting the legs (only on a few models)

Press-fit legs are supplied which fit under the base of your cooker (Fig. B).

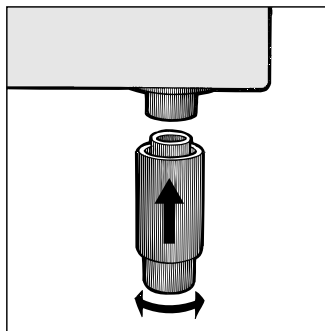
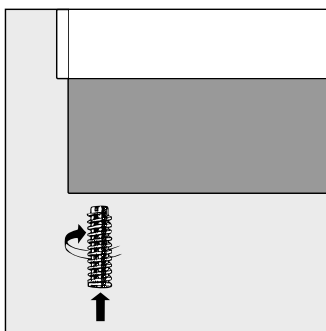

Fig. A

Fig. B

Electrical connection

Electric cookers come without a power supply cable. The cooker is designed to operate on an electricity supply which conforms to the electrical data shown on the Rating Plate. The cooker can be connected to the mains only after removing the back panel of the cooker itself with a screwdriver.

N.B.: the following installation procedure must be carried out by a qualified electrician. The electrical installation must comply with the IEE Regulations, Building & local By-Laws.

For the installation of the feeding cable carry out the following operations:

- Unscrew screw "V" (see fig. C)
- Pull and open the junction blok lid

Important: the wires in the mains lead are coloured in accordance with the following code:

Green & Yellow	Earth
Blue	Neutral
Brown	Live

As the colours of the wires in the mains lead may not correspond with the coloured markings identifying the terminals in your plug, proceed as follows:

Green & Yellow wire to terminal marked "E" or \perp or coloured Green or Green & Yellow.

Brown wire to terminal marked "L" or coloured Red.

Blue wire to terminal marked "N" or coloured Black (see fig. D).

- fix the feeding cable in the special cable stop and close the cover.

N.B.: the power supply cable must have these minimum requirements:

Type: H05RR-F

Section: 3x4 mm²

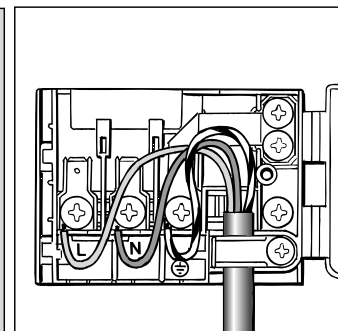
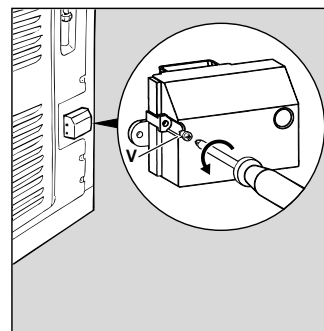

Fig. C

Fig. D

Connecting the supply cable to the mains

WARNINGS: THIS APPLIANCE MUST BE EARTHED.

Important: The cooker must be connected to the mains by a switched (double pole) cooker outlet correctly fused with a capacity appropriate to that shown on the cooker Rating Plate. All electrical wiring from the consumer unit to the cooker, via the switched double pole cooker outlet, must be of an acceptable type and current rating as above.

Note: the supply cable must be positioned so that it never reaches at any point a temperature 50°C higher than the room temperature. The cable must be routed away from the rear vents.

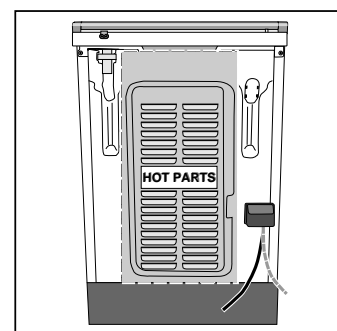

Technical Specifications

Oven

Dimensions (WxDxH) 39x41x34 cm
Volume 54 lt

Oven absorption Max

2000 W

Ceramic Hob

Front Left 1200 W
Back Left 1700 W
Back Right 1200 W
Front Right 1700 W
Hob Ceramic absorption Max 5800 W

ENERGY LABEL

Directive 2002/40/EC on the label of electric ovens

Norm EN 50304

Declared energy consumption for Forced convection Class heating mode: Fan assisted

Inner Dimensions of the Food Warmer:

Width: 42 cm

Depth: 44 cm

Height: 23 cm

Voltage and frequency

see data plate

Mains frequency and voltage of the electrical section

Model	Electric section	
	Voltage	Power (W)
K 3C36/G	240V~ 50 Hz	7800



This appliance conforms with the following European Economic Community directives:

- 73/23/EEC of 19/02/73 (Low Voltage) and subsequent modifications;
- 89/336/EEC of 03/05/89 (Electromagnetic Compatibility) and subsequent modifications;
- 93/68/EEC of 22/07/93 and subsequent modifications.
- 2002/96/EC

The European Directive 2002/96/EC on Waste Electrical and Electronic Equipment (WEEE), requires that old household electrical appliances must not be disposed of in the normal unsorted municipal waste stream. Old appliances must be collected separately in order to optimise the recovery and recycling of the materials they contain and reduce the impact on human health and the environment. The crossed out "wheeled bin" symbol on the product reminds you of your obligation, that when you dispose of the appliance it must be separately collected. Consumers should contact their local authority or retailer for information concerning the correct disposal of their old appliance.

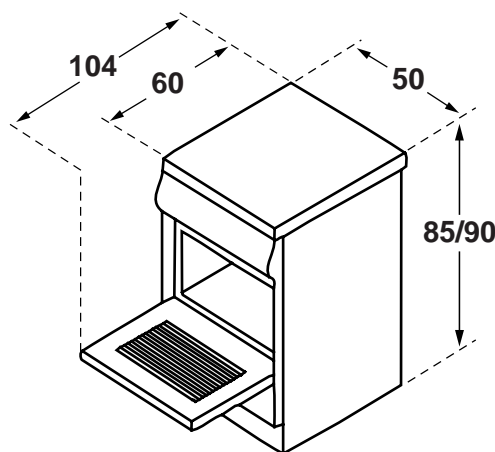

The cooker with electric ventilated oven and ceramic hob

- D. Dripping Pan or Baking Sheet
- E. Control Panel
- F. Adjustable Feet or Legs
- K. Oven Rack
- L. Selector Knob
- M. Variable grill Knob
- N. The control knobs for the electric plates
- O. Thermostat Light
- Q. The green pilot lamp
- R. The electronic cooking programmer (only on a few models)

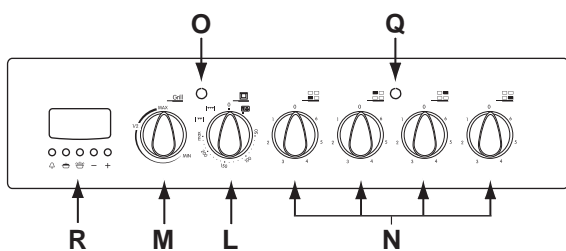
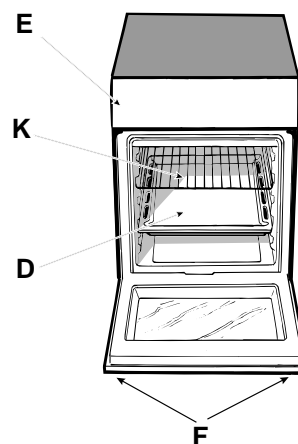



How To Use Your Appliance

The various functions included in the cooker are selected by operating the control devices located on the cooker control panel.

Notice: The first time you use your appliance, we recommend that you set the thermostat to the highest setting and leave the oven on for about half an hour with nothing in it, with the oven door shut. Then, open the oven door and let the room air. The odour that is often detected during this initial use is due to the evaporation of substances used to protect the oven during storage and until it is installed.

Attention: Only use the bottom shelf of the oven when using the rotisserie to cook (where present). For all other types of cooking, never use the bottom shelf and never place anything on the bottom of the oven when it is in operation because this could damage the enamel. Always place your cookware (dishes, aluminium foil, etc. etc.) on the grate provided with the appliance inserted especially along the oven guides.

N.B.: Should the appliance be equipped with an electronic programmer, to use the electric oven, just press buttons  and  at the same time (the  symbol will appear on the display) before selecting the desired cooking function.

Using the oven

When the oven control knob (L) is turned in a clockwise direction to the symbol  the fan and oven light will come on to assist in the defrosting of frozen food. Rotating further to the complete range of temperatures shown on the dial you can choose which is most suitable for the food you are going to cook. The temperature is reached automatically and controlled by the oven thermostat (from 50°C to Max).

Note: Whilst using tag oven for conventional cooking knob (M) must be set with "MAX" in line with the reference mark on the control panel.

Grill ||

The top centre heating element will come on. On this setting, food is cooked by the thermal radiation given off in the downward direction by the electric heating element. The very high temperature and direct heat of the grill make it possible to brown meats on the surface while locking in the juices to keep them tender.

Double Grill ||

Both of the top heating elements turn on. This over-sized grill has a completely new design, which is the reason why cooking efficiency has increased by 50%. In addition, the double grill eliminates heat gaps in the corners of the oven.

Oven Light

The light comes on when the "L" knob is turned to the  setting. The light illuminates the oven and remains on when any of the heating elements is turned on.

Thermostat Light (O)

This light indicates that the oven is heating. When it turns off, the temperature inside the oven has reached the setting made with the thermostat knob. At this point, the light will turn on and off as the oven maintains the temperature at a constant level.

Attention

Avoid the children touch the oven door because it is very hot during the cooking.

Important: when using the grill, the oven door must be left partly open by positioning the deflector "D" between door and panel to prevent the cooker knobs from overheating.

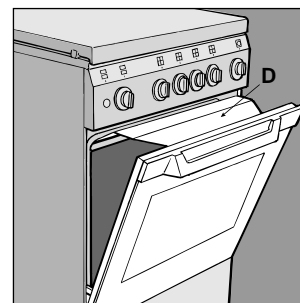





Electronic Cooking Programmer

This feature allows you to program the oven or the grill as follows :





- delayed start for a specific length of time;
- immediate start for a specific length of time;
- timer.

Button Functions:

-  : timer - hours and minutes;
-  : cooking time;
-  : end cooking time;
-  : set cooking time - backward;
-  : set cooking time - forward.

How to reset the digital clock.

After the appliance has been connected to the power supply, or when the power has gone out, the clock display will automatically reset to **0:00** and begin to blink.

- Press the  and  buttons consecutively and then reset the time (within 4 seconds) using the  and  buttons.



The  button sets the time forward.

The  button sets the time backward.

Whenever the time must be reset, follow this same procedure.



Manual Operation of the Oven

After resetting the time, the program automatically switches to the manual mode.

Note: To reset the manual mode after each “automatic” cooking, press the  and  buttons simultaneously.



Start delayed cooking with preset duration

The length of the cooking program as well as the time at which the cooking program ends must be set. If we assume that the time displayed on the timer is 10:00:

1. Turn the oven control knobs to the feature and temperature desired (e.g. conventional oven, 200°C);
2. Press the  button and then set the cooking time (within four seconds) using the  and  buttons. Let us suppose that we set the cooking time at 30 minutes. The display will read as follows:





After the button has been released, the current time will be displayed again after approximately 4 seconds, along with the  symbol and the letter “A” (AUTO);



3. Press the  button and then use the  and  buttons to set the time for when the cooking program should end. Let us suppose this time to be 1:00 p.m.



4. After the button has been released, the current time will be displayed after approximately 4 seconds:



The letter “A” will light up reminding you that the length and end cooking time were programmed in automatic mode. At this point, the oven will turn on automatically at 12:30 and then turn off after 30 minutes. When the oven is turned on, the  symbol will be displayed for the entire cooking time. At any time during the cooking process, the length of the cooking time can be displayed by pressing the  button, and the end cooking time by pressing the  button.

After the cooking time has expired, the timer will ring for several minutes; to turn it off, simply press any of the buttons except the  and  buttons.

Immediate start with preset duration

By programming just the duration (points 1 and 2 of the “Start delayed cooking with preset duration” section), cooking will start up immediately.

To cancel a cooking schedule already programmed



Press the  and  buttons simultaneously.

Timer Feature



The timer feature allows you to enter a given amount of time from which the timer begins to count down. This feature does not turn the oven on or off; it merely sounds when the time has expired.

When the  button has been pressed, the display will read as follows:





Then use the  and  buttons to set the desired time. After the button has been released, the timer will start to count down and the current time will be displayed.



After the time has expired, an acoustical signal will be emitted, which can be turned off by pressing any of the buttons (except the  and  buttons) at this point the  symbol will also turn off.

Correction/Cancellation of Data

- The data entered can be changed at any time by pressing the corresponding button and the  or  buttons.
- When the data for the length of the cooking time is cancelled, the data for the end cooking time are also cancelled automatically, and vice versa.
- If the oven has been programmed, it will not accept end cooking times which are before the start of the cooking process.

Buzzer volume control

Once you have made and confirmed the clock settings, use button  to adjust the volume of the alarm buzzer.

Cooking advice

The oven offers a wide range of alternatives which allow you to cook any type of food in the best possible way. With time you will learn to make the best use of this versatile cooking appliance and the following directions are only a guideline which may be varied according to your own personal experience.

Using the Grill

Grilling may be carried out with a two stage heating element situated in the top of the oven chamber. The centre, or the complete area of the grill can be selected by turning the oven control knob (L) in a clockwise direction to align the symbols (|▼| for the centre, |▼▼| for the complete area) with the mark on the control panel. The variable temperature control (M) is positioned to right of the oven knob. This knob will provide varying grill temperatures when rotated from “max” to “min” and may be adjusted to vary the level of heat at any time during the grilling operation.

To operate the grill

1. Turn the oven control knob (L) clockwise until the required grilling symbol is in line with the mark on the control panel. The element is now “on”.
2. The variable grill control (M) can now be operated to select the required heat.

Important: when using the grill, the oven door must be left partly open.

When using the grill, place the rack at the 4 rack heights (see cooking table) and place the dripping-pan beneath the oven rack to prevent grease from falling onto the bottom of the oven.

Baking Pastries

When baking pastries, always place them in the oven after it has been preheated. Make sure you wait until the oven has been preheated thoroughly (the red “O” light will turn off). The temperature is normally around 160°C. Do not open the door while the pastry is cooking in order to prevent it from dropping. Batters must not be too runny, as this will result in prolonged cooking times. In general:

Pastry is too dry

Increase the temperature by 10°C and reduce the cooking time.

Pastry dropped

Use less liquid or lower the temperature by 10°C.

Pastry is too dark on top

Place it on a lower rack, lower the temperature, and increase the cooking time.

Cooked well on the inside but sticky on the outside

Use less liquid, lower the temperature, and increase the cooking time.

The pastry sticks to the pan

Grease the pan well and sprinkle it with a dusting of flour.

I used more than one level and they are not all at the same cooking point

Use a lower temperature setting. It is not necessary to remove the food from all the racks at the same time.

Cooking fish and meat

When cooking white meat, fowl and fish use low temperatures. (150°C-175°C). When red meat must be superficially well-cooked but succulent inside, it is advisable to start with a high temperature (200-220°C) for a short time, and then to reduce it at a later point. Generally speaking, the more meat there is, the lower the temperature and the longer the cooking time should be. Place the meat in the centre of the grid and put a spill-tray underneath to catch grease drips. Insert the grid so that it is in the middle of the oven. If more heat from below is required, use the 1° bottom shelf.

User's instructions the ceramic hob

Description

The hobs have been provided with radiant electric heaters. These heaters are incorporated under the surface of the hob as zones which redden while they are in use.

A. Cooking area (A).

B. A lights which indicate whether the corresponding heaters are at a temperature in excess of 60° C; even if the hob/zone has been switched off.

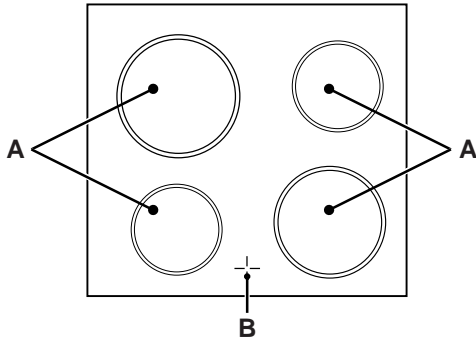

Description of the heating elements

The **radiant heating elements** are composed of circular heating elements. They only become red after being turned on for 10-20 seconds.

Instructions for using the pyroceram top

To obtain the best results from your hob, there are some basic rules to follow when cooking or preparing food.

- All types of pots and pans may be used on the ceramic glass cooktop. However, the bottom surface must be perfectly flat. Naturally, the thicker the bottom of the pot or pan, the more uniformly the heat is distributed.



- Make sure that the base of the pan completely covers the cooking ring, so as to make full use of the heat produced



- Always make sure that the pan base is always dry and clean so as to guarantee proper contact as well as longer-lasting pans and the long life-span of the hob.
- Do not use the same pans which are used for cooking on gas burners. The heat strength of gas burners may deform the pan base and will not give the same results if it is subsequently used on a glazed ceramic hob.

Practical advice for using the electric plates

The cook-top electric plate control knobs (N)

The cookers may be equipped with standard, fast and automatic electric plates in various combinations (the fast plates distinguished from the others by a red dot in the centre, the automatic ones by a round aluminium disk at the centre).

To avoid heat dispersion and damage to the plates, recommend using cooking vessels with flat bottoms in diameters which are not smaller than the plate diameter. Table shows the correspondence between the position indicated on the knobs and the use for which the plates advised.

Setting	Normal or Fast Plate
0	Off
1	Cooking vegetables, fish
2	Cooking potatoes (using steam) soups, chickpeas, beans.
3	Continuing the cooking of large quantities of food, minestrone
4	For roasting (average)
5	For roasting (above average)
6	For browning and reaching a boil in a short time.

The green pilot lamp (Q)

This lights up when an electric plate is turned on.

Cooking advice

Food to be cooked	Wt. (wt)	Cooking position of shelves from bottom	Temperature (°C)	Variable grill	Pre-heating time (min)	Cooking time (min.)
Pasta						
Lasagne	2.5	3	210	MAX	-	75-80
Cannelloni	2.5	3	210		-	75-80
Oven-baked noodles	2.5	3	210		-	75-80
Meat						
Veal	1.7	3	230	MAX	-	85-90
Chicken	1.5	3	220		-	110-115
Turkey	3.0	3	MAX		-	95-100
Duck	1.8	3	230		-	120/125
Rabbit	2	3	230		-	105/110
Pork	2.1	3	230		-	100/110
Lamb	1.8	3	230		-	90-95
Fish						
Mackerel	1.1	3	210-230	MAX	-	55-60
Dentex	1.5	3	210-230		-	60-65
Trout baked in paper	1.0	3	210-230		-	40-45
Pizza						
Napolitan	1.0	3	MAX	MAX	15	30-35
Cake						
Biscuits	0.5	3	180	MAX	15	30-35
Tarts	1.1	3	180		15	30-35
Chocolate cake	1	3	200		15	45-50
Raised Cakes	1	3	200		15	50/55
Grill cooking						
Toast	n.° 4	4		3/4	5	5-6
Pork chops	1.5	4			5	20-30
Mackerel	1.1	4			5	20-30

Note: cooking times are approximate and may vary according to personal taste.

Routine maintenance and cleaning of the oven

Disconnect the oven from the source of electricity before performing any maintenance or cleaning. To ensure a long life for your oven, clean it frequently and carefully, keeping in mind that:

- Do not use steam equipment to clean the appliance.
- the enamelled parts and the self-cleaning panels should be washed with warm water without the addition of abrasive powders or corrosive substances which could damage the finish;
- The inside of the oven should be cleaned fairly often while it is still warm, using warm water and detergent followed by careful rinsing and drying;
- stainless steel may become marked if it comes into contact with very hard water or harsh detergents (containing phosphorous) for long periods of time. After cleaning, it is advisable to rinse thoroughly and dry. It is also recommended to dry any water drops;
- avoid dirt and grease accumulating on the control panel by cleaning it frequently. Use non-abrasive sponges or soft cloths to avoid scratching enamelled or shiny steel parts.

Cleaning the hob surface

Prior to cooking, the hob surface should always be cleaned using a damp cloth to remove any dust or stray food particles. The hob surface should be regularly cleaned with a lukewarm solution of water and a mild detergent. Periodically it may be necessary to use a proprietary ceramic hob cleaner. First remove all spilt food and fat with a window scrape, preferably the razor blade type **CERA** (not supplied) or, failing that, the fixed blade razor edge type.

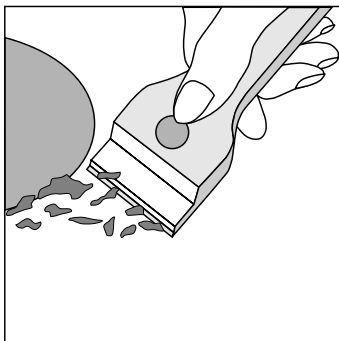

Then clean the hob while it is still warm to the touch with a suitable cleaner and paper towel. Then rinse it and wipe it dry with a clean cloth. If aluminium foil or plastic items are accidentally allowed to melt on the hob surface they should be **immediately** removed from the hot cooking area with a scraper. This will avoid any possible damage to the surface. This also applies to sugar or any food with a high sugar content. Do not use abrasive sponges or scourers of any type. Corrosive cleaners such as oven sprays and stain removers should also not be used.

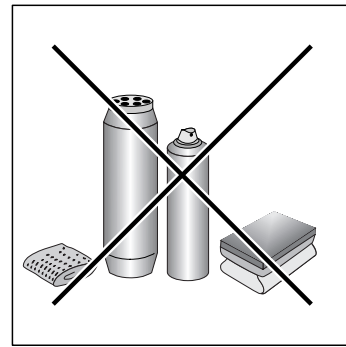

Glass ceramic hob cleaners	Available from
Window scraper Razor blade scrapers	DIY Stores
Replacement blades	DIY Stores, supermarkets, chemists
COLLO luneta HOB BRITE Hob Clean SWISSCLEANER	Boots, Co-op stores, department stores, Regional Electricity Company shops, supermarkets

Replacing the oven light bulb

- Either pull out the plug (if it is accessible) or disconnect the oven from the mains by turning off the multipole switch used for connecting the oven to the electricity source;
- Remove the glass cover of the lamp holder;
- Unscrew the bulb and replace it with a high temperature resistant bulb (300°C) with the following characteristics:
 - Voltage 230/240 V
 - Wattage 25W
 - Type E14
- Replace the glass cover and reconnect the power supply to the oven.

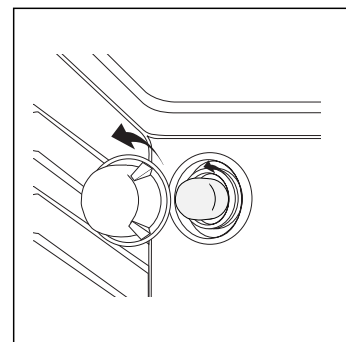

Indesit Company
viale Aristide Merloni, 47
60044 Fabriano (AN) Italy
tel. +39 0732 6611
www.indesit.com

Cucina con forno elettrico ventilato e piano VTC (Spec. GB)
04/05 - 195049681.00

Free Manuals Download Website

<http://myh66.com>

<http://usermanuals.us>

<http://www.somanuals.com>

<http://www.4manuals.cc>

<http://www.manual-lib.com>

<http://www.404manual.com>

<http://www.luxmanual.com>

<http://aubethermostatmanual.com>

Golf course search by state

<http://golfingnear.com>

Email search by domain

<http://emailbydomain.com>

Auto manuals search

<http://auto.somanuals.com>

TV manuals search

<http://tv.somanuals.com>