

POWER STEERING

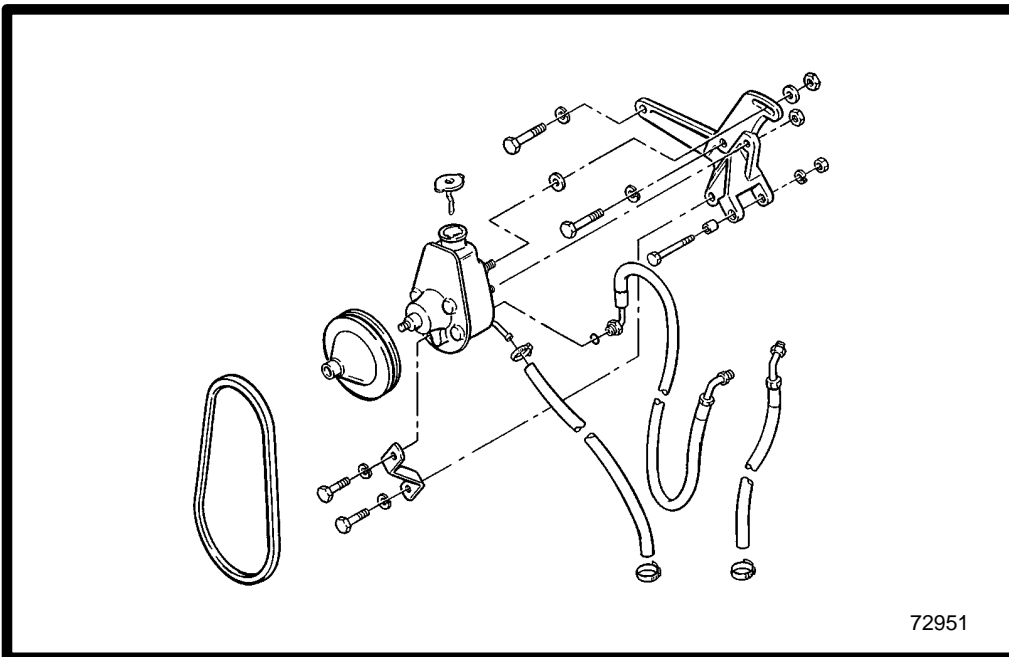

PUMP

8

A

Table of Contents

	Page
Torque Specifications	8A-1
Tools/Sealants	8A-1
Precautions	8A-1
Power Steering Pump and Components (Exploded View)	8A-2
Serpentine Belt Routing	8A-3
Important Service Information	8A-4
Pump Pulley Replacement	8A-4
Testing and Repair	8A-5
Checking Pump Fluid Level	8A-5
Filling and Air Bleeding System	8A-5
Belt Adjustment	8A-5
V-Belt	8A-5
Serpentine Belt Adjustment	8A-5
Pump Assembly	8A-6
Mounting Bracket	8A-7
Hydraulic Hoses and Fluid Cooler	8A-7
High Pressure Hose (Pump-to-Control Valve)	8A-7
Low Pressure Hose (Cooler-to-Pump)	8A-8
Low Pressure Hose (Control Valve-to-Cooler)	8A-10
Priority Valve Kit (79691A1) Information	8A-12
Installing Reservoir	8A-12
Installing Priority Valve	8A-14
Filling System with Fluid	8A-17
Maintenance	8A-17
System Flow Diagram	8A-18

Torque Specifications

Fastener Location	Lb. Ft.	Lb. In.	N·m
Crankshaft Pulley To Torsional Damper	35		42
Torsional Damper To Crankshaft	60		81
Pump Mounting Bracket To Engine	30		41
Recirculation Pump Pulley		240	27
Early Style Power Steering Hose Fittings	Large	20-25	27-34
Early Style Power Steering Hose Fittings	Small	96-108	11-12
Later Style Power Steering Hose Fittings	23		31

Tools/Sealants

Description	Part Number
Pulley Installer	91-93656A1
Quicksilver Perfect Seal	92-34227-1
Pulley Removal Tool (Kent-Moore)	J-25034

Kent-Moore Special Tools
29784 Little Mack
Roseville, MI 48066
(313) 574-2332

Precautions

CAUTION

Do not operate engine without cooling water being supplied to water pickup pump or water pump impeller will be damaged and subsequent overheating damage to engine may result.

WARNING

Always disconnect battery cables from battery before working on engine to prevent fire or explosion.

CAUTION

Do not pry on power steering pump or alternator when adjusting belt tension. Serious damage may result.

Power Steering Pump and Components (Exploded View)

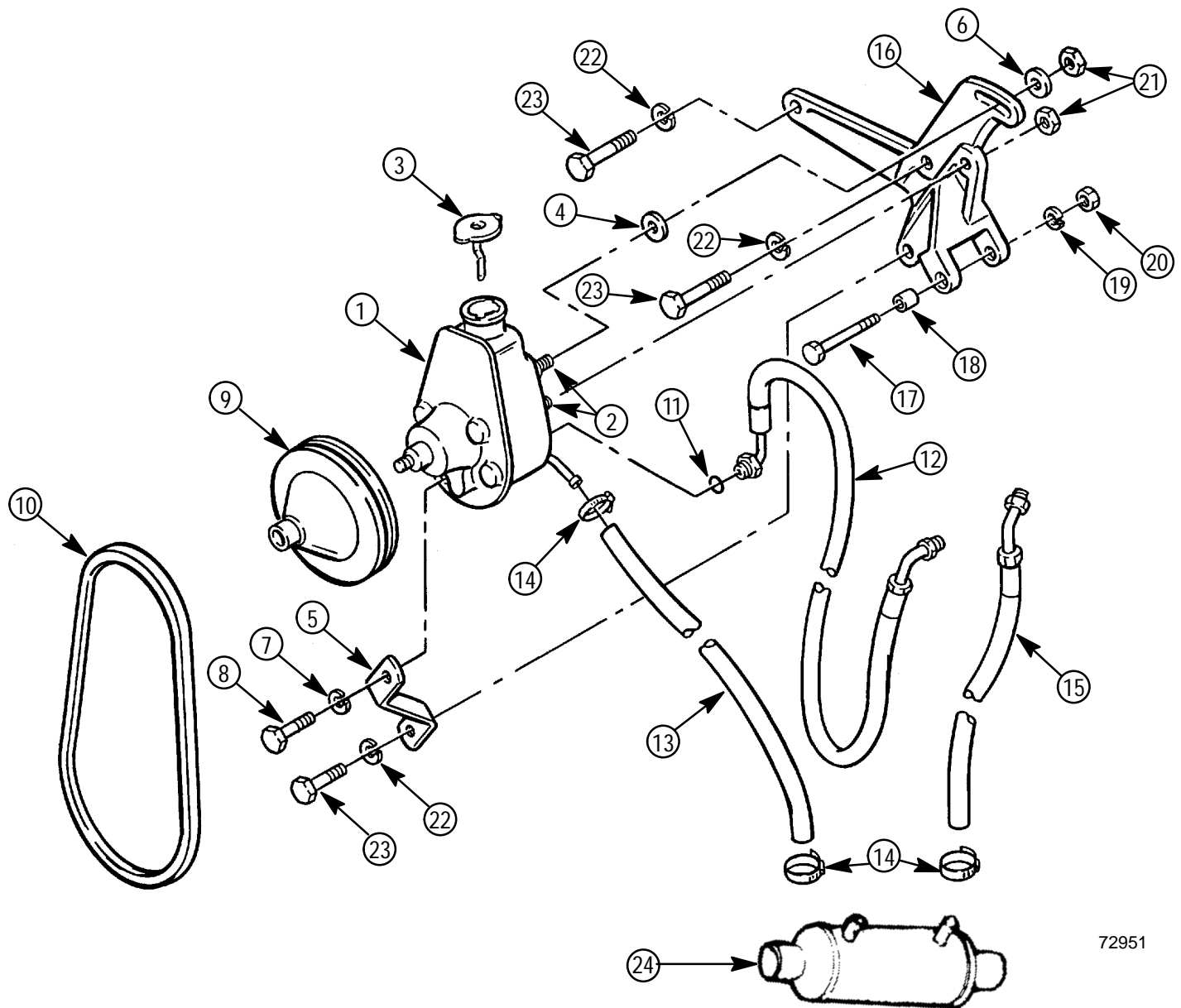

72951

- 1 - Power Steering Pump Assembly
- 2 - Stud
- 3 - Cap
- 4 - Spacer
- 5 - Brace
- 6 - Spacer
- 7 - Lockwasher
- 8 - Bolt, Pump To Brace
- 9 - Pulley
- 10 - Belt
- 11 - O-Ring, High Pressure Hose Fitting
- 12 - Hose, High Pressure (Fittings on Both Ends)

- 13- Hose, Pump To Fluid Cooler
- 14- Clamp
- 15- Hose, Control Valve To Fluid Cooler (Fitting On One End)
- 16- Mounting Bracket, Cast
- 17- Bolt
- 18- Spacer (Barrel Shaped)
- 19- Lockwasher
- 20- Nut (For Item 17)
- 21- Nut (For Item 21)
- 22- Lockwasher
- 23- Bolt To Cylinder Block
- 24- Power Steering Cooler

Serpentine Belt Routing

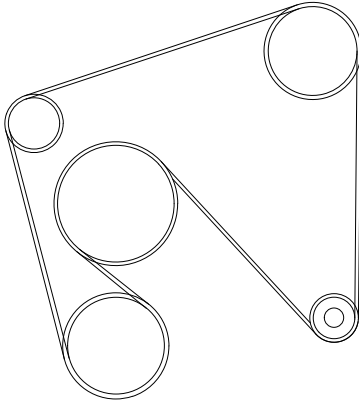

ALPHA WITH POWER STEERING

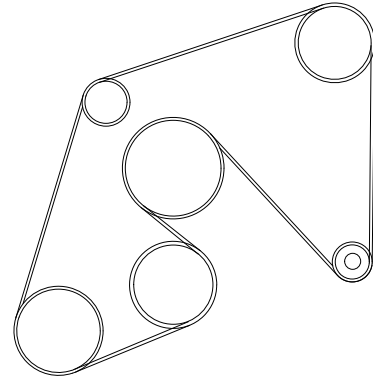

BRAVO WITH POWER STEERING

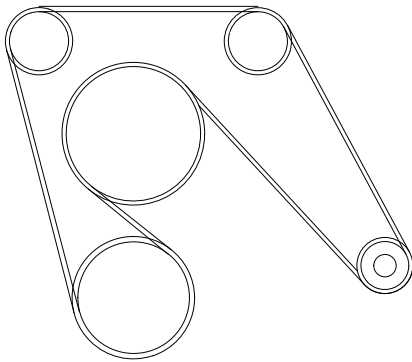

**ALPHA WITH CLOSED COOLING
WITHOUT POWER STEERING**

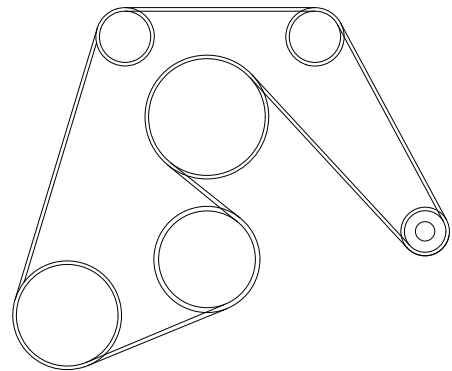

BRAVO WITHOUT POWER STEERING

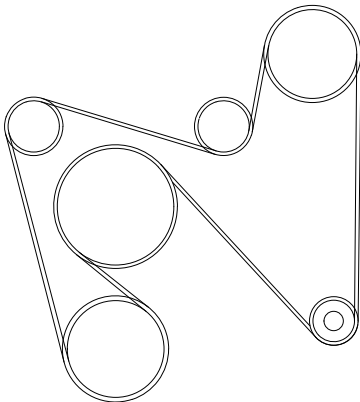

**ALPHA WITH CLOSED COOLING AND
POWER STEERING**

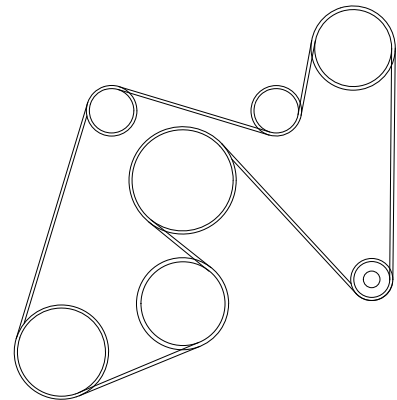

**BRAVO WITH CLOSED COOLING
AND POWER STEERING**

Important Service Information

Pump Pulley Replacement

REMOVAL

IMPORTANT: Kent-Moore Tool J-25034 must be used to remove the pressed-on pulleys used on power steering pumps. This tool has an end on it that will not mushroom the end of the pump shaft. **DO NOT** use Kent-Moore Tool J-21239 to remove these pulleys. This tool has a tapered end and will damage the shaft.

1. Install Kent-Moore Tool J-25034 on end of pulley and shaft as shown.
2. While holding tool with suitable wrench, turn threaded screw until pulley is removed.

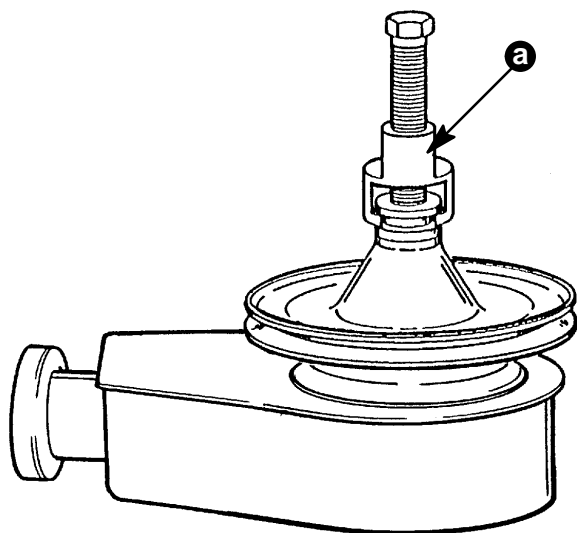

72821

a - Kent-Moore Pulley Removal Tool (J-25034)

INSTALLATION

Install pulley, as follows, using pulley installer tool (91-93656A1), and a long straight edge:

1. Place pulley on pump shaft.
2. Thread stud all the way into pump shaft. Place bearing over stud. Do not use spacer from kit.
3. Thread nut onto shaft. Thread tool shaft (and nut) all the way onto stud (threaded into pump pulley).
4. Using a long straight edge (to check drive belt alignment), turn large pusher nut until drive belt is parallel to straight edge.
5. Check pulley installation for correct alignment.

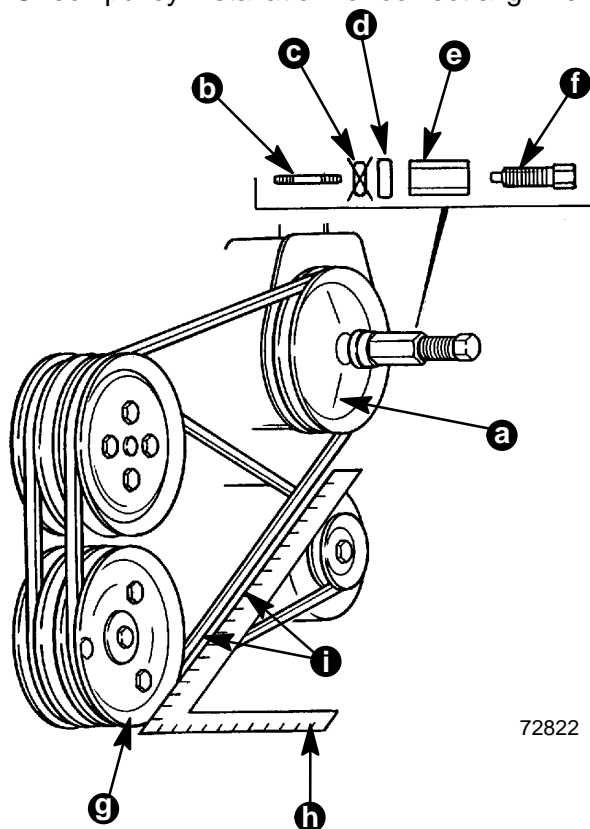

72822

- a - Power Steering Pump Pulley
- b - Stud
- c - Do Not Use Spacer
- d - Bearing
- e - Nut
- f - Tool Shaft
- g - Crankshaft Pulley (shown) Or Water Circulating Pump Pulley
- h - Long Straight Edge
- i - Drive Belt Parallel

Testing and Repair

Refer to appropriate MerCruiser Stern Drive Service Manual.

Checking Pump Fluid Level

Refer to Section 1B - "Maintenance" (see "Table of Contents").

Filling and Air Bleeding System

Refer to Section 1B - "Maintenance" (see "Table of Contents").

Belt Adjustment

V-Belt

IMPORTANT: Do not pry on power steering pump with pry bar or screwdriver. Serious damage may result.

1. Install drive belt on pulleys and adjust tension as follows:
 - a. Pivot pump away from engine, as required, until correct tension is obtained, as shown.
 - b. After obtaining correct tension, securely tighten pump brace and pump mounting bolts.
2. If a new drive belt has been installed, recheck belt tension after running for five minutes.

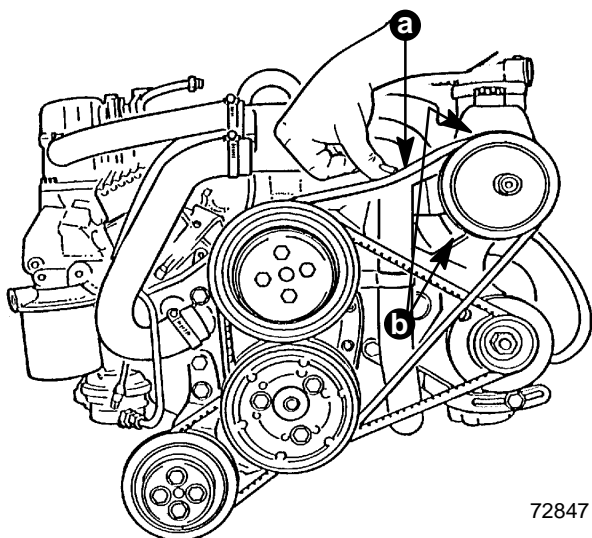

72847

- a - Belt Should Depress 1/4 In (6 mm)
b - Screws and Nuts

Serpentine Belt Adjustment

1. Using a 5/8 inch wrench, loosen the nut on the adjustment stud.
2. Place the 5/16 inch deep socket on the hex end of the adjustment stud rotate starboard tensioner until there is 1/4 inch (6 mm) deflection is achieved between the pulleys with the greatest distance between them (this location may be different with various belt configurations).
3. While holding adjustment stud at the correct belt tension, tighten locking nut.

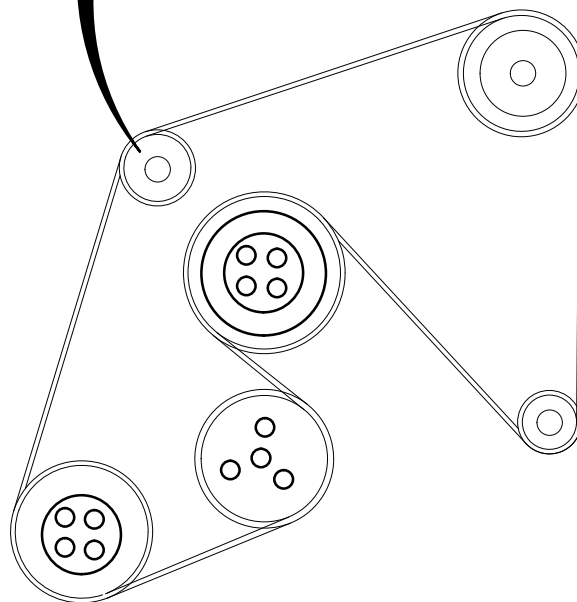
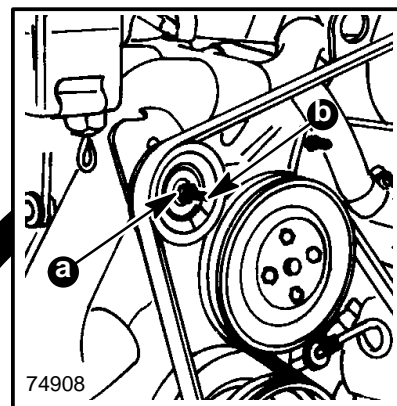

Bravo Model With Power Steering Shown (Other Configurations Will Be Different)

- a - Locking Nut
b - Adjustment Stud

Pump Assembly

IMPORTANT: Be careful to not cross-thread or over-tighten hose fittings.

1. Be certain a new high pressure hose O-ring is present, and install threaded fitting in back of pump assembly. Tighten fitting securely. Connect low pressure hose on back of pump. Tighten hose clamp securely.

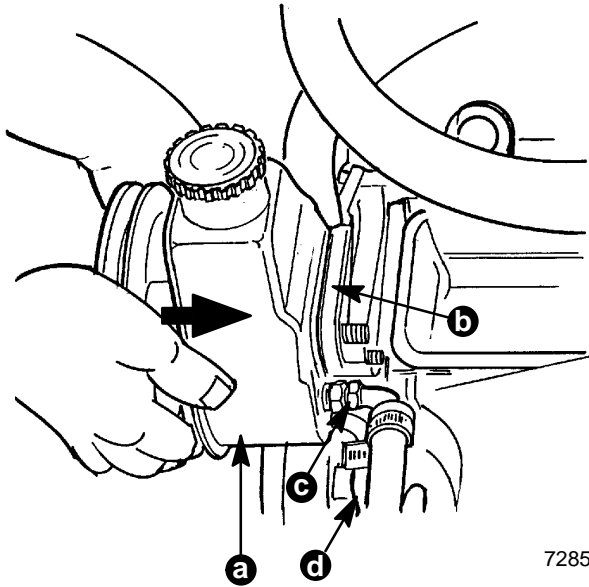

72850

- a - Pump
- b - Bracket
- c - Threaded Fitting
- d - Low Pressure Hose

2. Install mounting hardware and fasteners to retain pump to bracket. (Refer to "Exploded View" for specific details on your engine.)

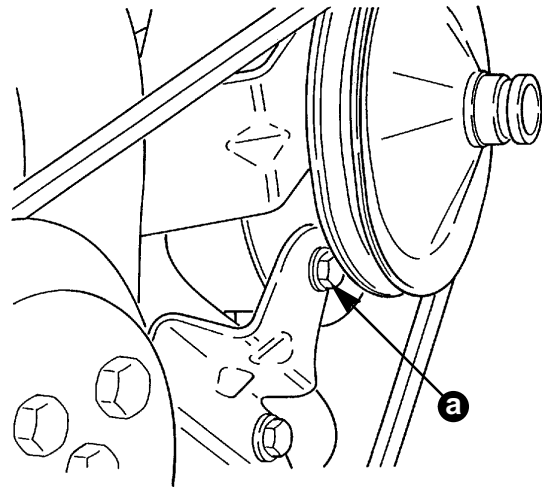

72849

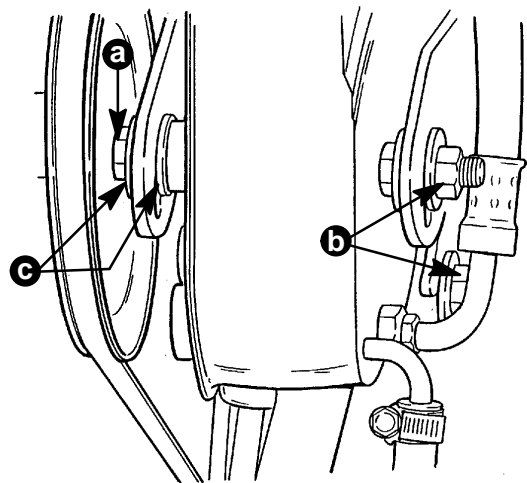

72848

- a - Screw With :Lockwasher
- b - Nuts (With Hardware)
- c - Spacers

3. Install drive belt and adjust tension. Refer to "Pump Drive Belt Adjustment" as previously outlined.
4. Fill and air bleed system. Refer to Section 1B - "Maintenance" (see "Table of Contents").

Mounting Bracket

Mounting bracket is removable after pump (refer to previous instructions) and alternator (refer to Section 4C - "Charging System") have been removed. See "Exploded View" and "Torque Specifications."

Hydraulic Hoses and Fluid Cooler

Refer to Section 6A - "Seawater Cooled Models" or Section 6B - "Closed Cooled Models" for information on testing or servicing power steering fluid coolers. The following is provided to assist in replacement of power steering fluid hoses and to assure proper routing and connection to the cooler.

Replace high or low pressure hoses following:

IMPORTANT: Make hydraulic connections as quickly as possible to prevent fluid leakage.

IMPORTANT: Be careful to not cross-thread or over-tighten hose fittings.

High Pressure Hose (Pump-to-Control Valve)

REMOVAL

NOTE: Catch fluid that drains from pump and hoses in a suitable container.

1. Remove high pressure hose fitting and O-ring seal from rear of pump.

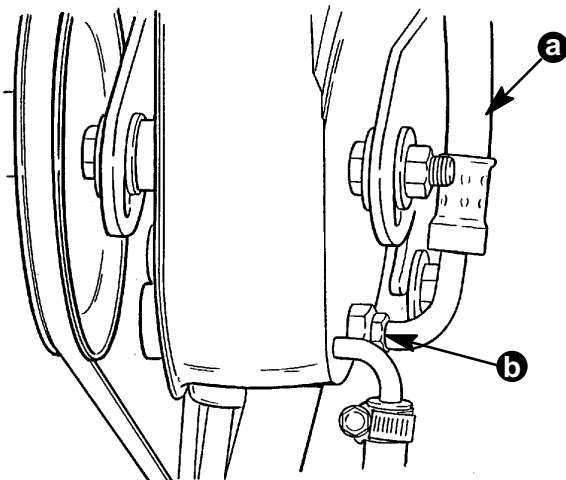

72848

a - High Pressure Hose
b - Fitting (With O-Ring - Not Visible In This View)

2. Remove hose where routed and secured (port or starboard side), across top of engine, near valve cover.
3. Remove small fitting from control valve at transom. Remove hose.

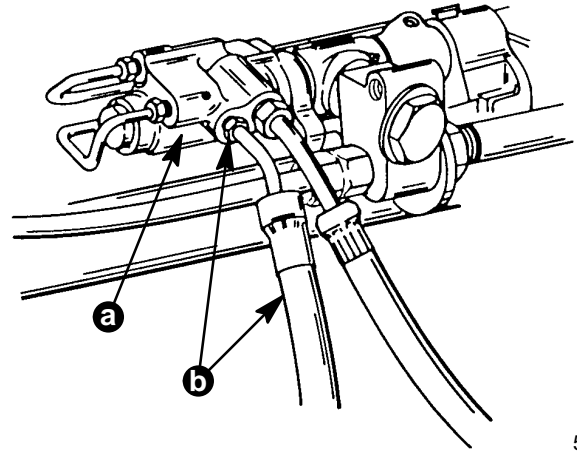

50912

a - Control Valve
b - Small Fitting And Hose

INSTALLATION

CAUTION

Route hoses exactly as shown below. This will help avoid stress on the hose fittings and will help avoid kinks in the hoses.

IMPORTANT: Be careful to not cross-thread or over-tighten hose fittings.

1. Thread small fitting into control valve. Position hose properly (as prior to removal).

Earlier Style Control Valve: Torque small fitting to 96-108 lb. in. (11-12 N·m).

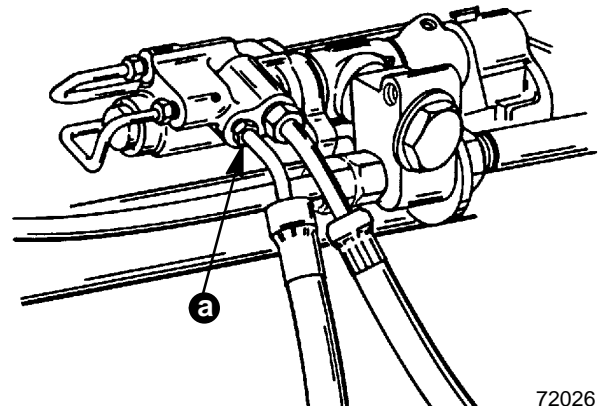

72026

a - Small Fitting

Later Style Control Valve: Torque fittings to 23 lb. ft. (31 N·m)

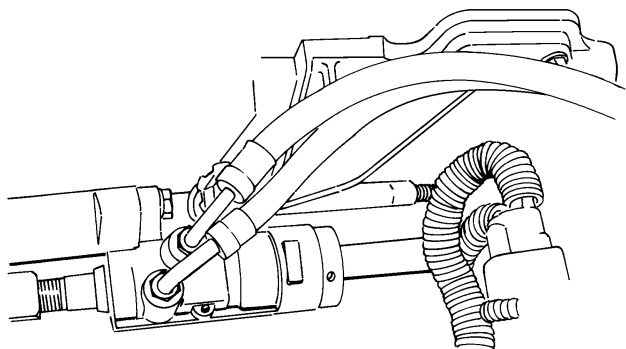

73786

2. Route hose along valve cover and secure with J-clamp(s) provided.
3. Be certain a new high pressure hose O-ring is present, and install threaded fitting in back of pump assembly. Tighten fitting securely. Do not cross-thread or over-tighten.

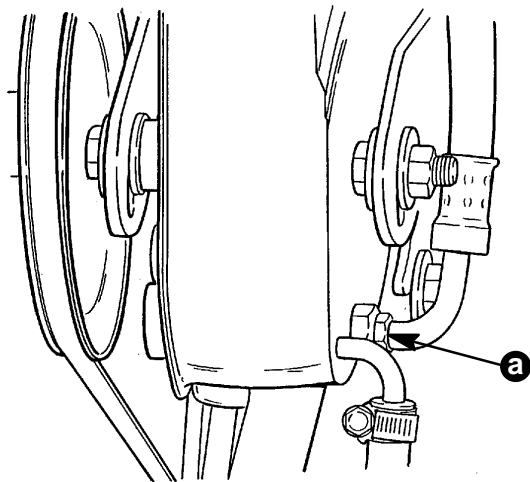

72848

a - Fitting (With O-Ring - Not Visible In This View)

4. Fill and air bleed system. Refer to Section 1B - "Maintenance" (see "Table of Contents").

Low Pressure Hose (Cooler-to-Pump)

REMOVAL

NOTE: Catch fluid that drains from hose, cooler and pump in a suitable container.

1. Loosen hose clamp and remove hose from fluid cooler.

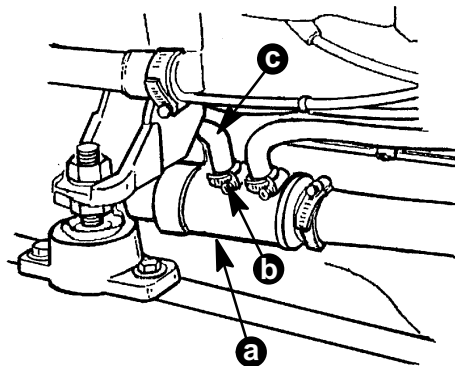

72588

Port Side Mounted Fluid Cooler

- a - Fluid Cooler
- b - Hose Clamp
- c - Hose

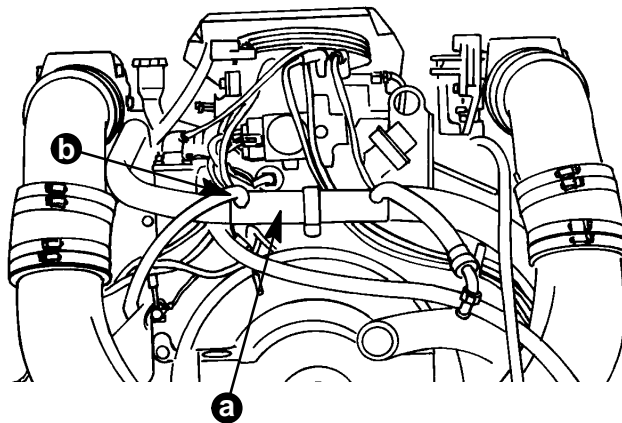

74752

Rear Mounted Fluid Cooler

- a - Fluid Cooler
- b - Hose

- Loosen hose clamp and remove hose from back of pump.

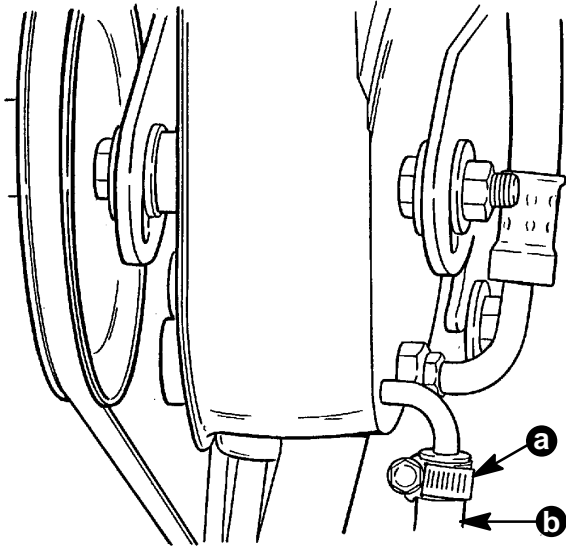

72848

- a - Hose Clamp
- b - Hose

INSTALLATION

- Using hose clamp, install new hose on back of pump. Tighten clamp securely.

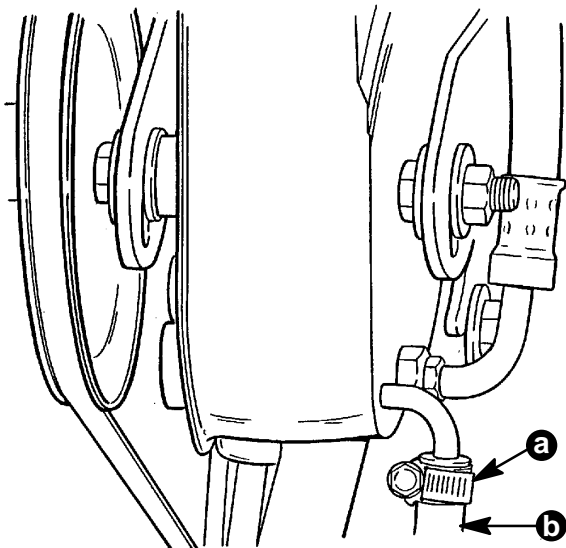

72848

- a - Hose Clamp
- b - Hose

- Using hose clamp, install hose on fluid cooler. Tighten clamp securely.

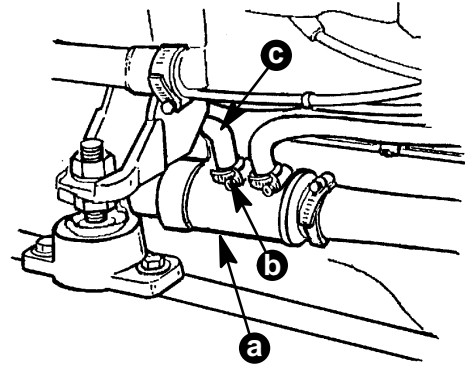

72588

Port Side Mounted Fluid Cooler

- a - Fluid Cooler
- b - Hose Clamp
- c - Hose

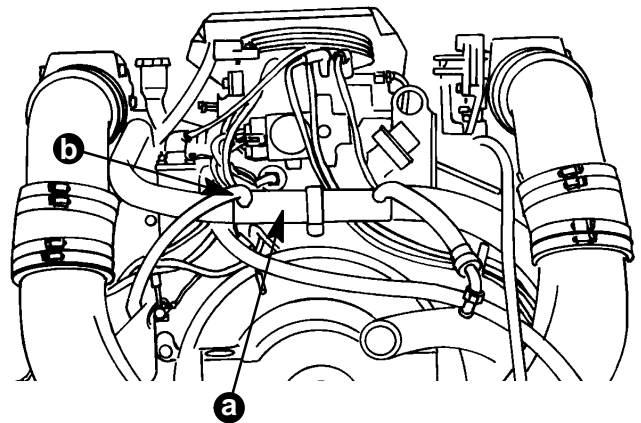

74752

Rear Mounted Fluid Cooler

- a - Fluid Cooler
- b - Hose

- Fill and air bleed system. Refer to Section 1B - "Maintenance" (see "Table of Contents").

Low Pressure Hose (Control Valve-to-Cooler)

REMOVAL

NOTE: Catch fluid that drains from hose, cooler and pump in a suitable container.

1. Loosen hose clamp and remove hose from fluid cooler.

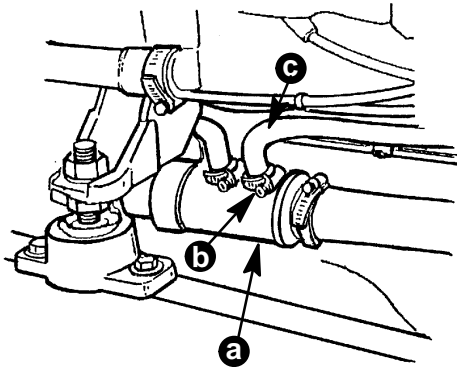

72588

Port Side Mounted Fluid Cooler

- a - Fluid Cooler
- b - Hose Clamp
- c - Hose

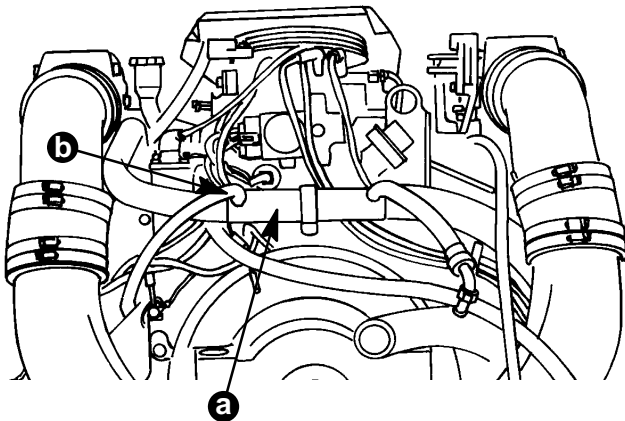

74752

Rear Mounted Fluid Cooler

- a - Fluid Cooler
- b - Hose

2. Remove hose where routed and secured across top of engine flywheel housing.

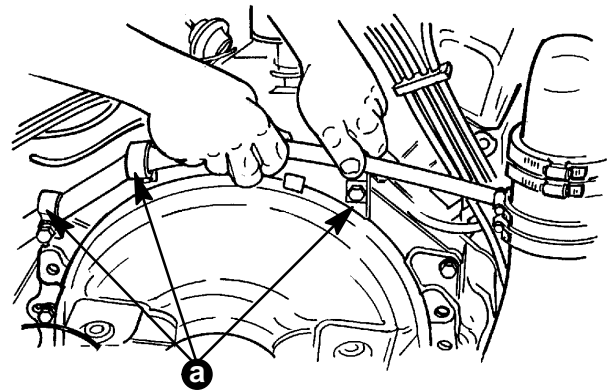

72853

Port Side Mounted Fluid Cooler Only

- a - J-Clamps

3. Remove large fitting from control valve at transom. Remove hose.

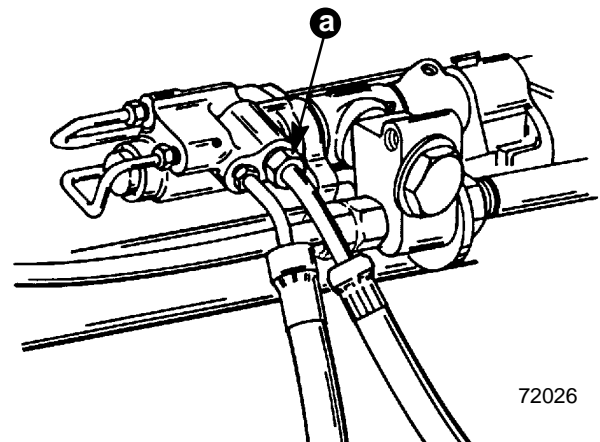

72026

Earlier Style Control Valve

- a - Large Fitting

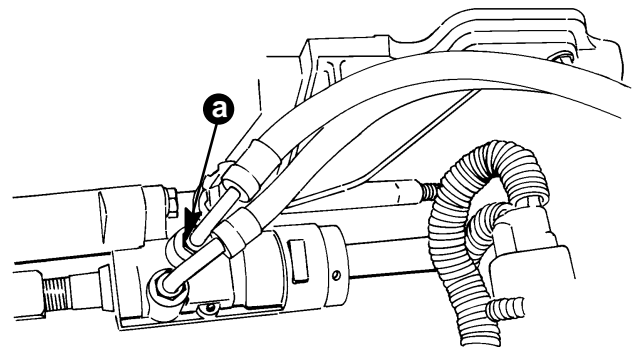

73786

Later Style Control Valve

- a - Rear Fitting

INSTALLATION

CAUTION

Route hoses exactly as shown below. This will help avoid stress on the hose fittings and will help avoid kinks in the hoses.

IMPORTANT: Be careful to not cross-thread or over-tighten hose fittings.

1. Thread large fitting into control valve. Position hose properly (as prior to removal).

Earlier Style Control Valve: Torque large fitting to 20-25 lb. ft. (27-34 N·m).

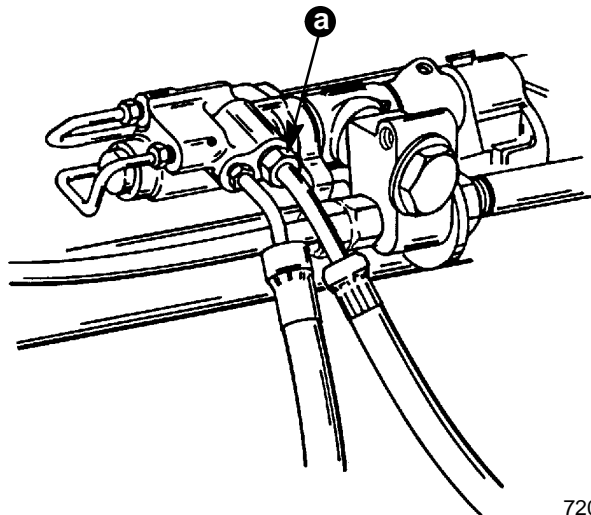

a - Large Fitting

Later Style Control Valve: Torque fittings to 23 lb. ft. (31 N·m)

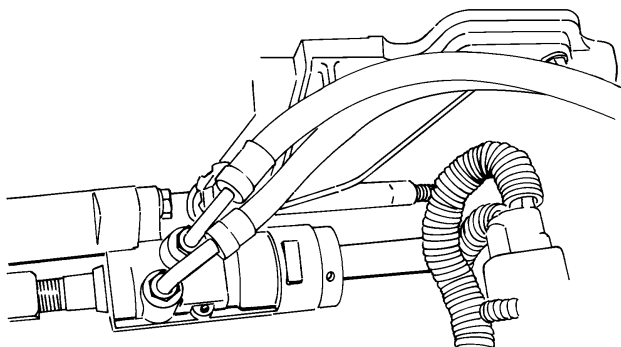

73786

2. Route hose along flywheel housing and secure with J-clamp(s) provided.

3. Using hose clamp, install hose on fluid cooler. Tighten clamp securely.

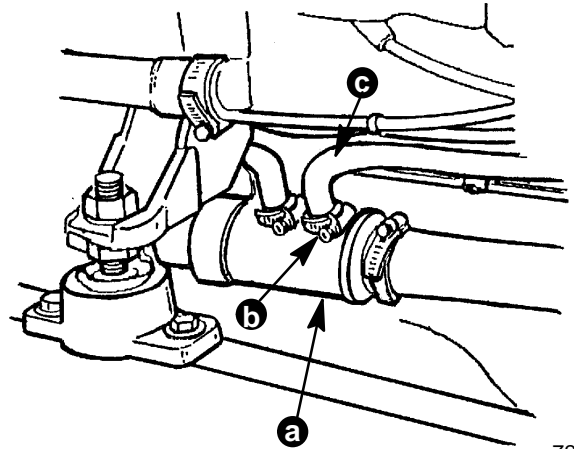

72588

Port Side Mounted Fluid Cooler

a - Fluid Cooler
b - Hose Clamp
c - Hose

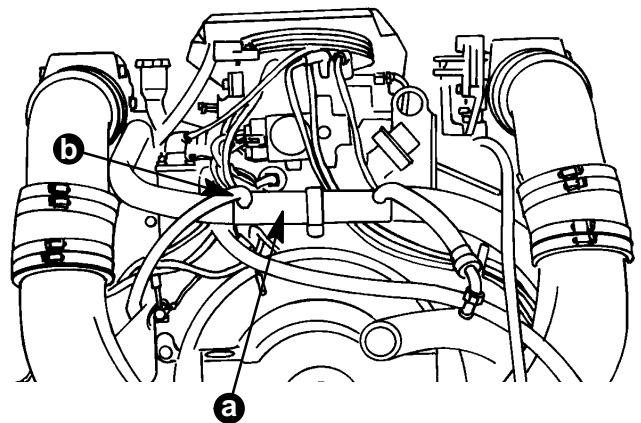

74752

Rear Mounted Fluid Cooler

a - Fluid Cooler
b - Hose

4. Fill and air bleed system. Refer to Section 1B - "Maintenance" (see "Table of Contents").

Priority Valve Kit (79691A1) Information

This kit information (in "Installation Instruction" form) is provided to assist personnel when servicing dual installations where both engines are equipped with power steering pumps, coolers, related hardware and hoses, and one transom assembly is equipped with power steering.

Although the system may already be installed, refer to appropriate sections and follow instructions that relate to your task when servicing those components.

NOTE: A system flow diagram is located on the last page of this section.

Installing Reservoir

1. Mount reservoir bracket.
 - a. Find a location between both power steering pumps that affords both accessibility and easy visual inspection of fluid level. Location must be at least 6 in. (152 mm) higher than pump cap to allow fluid from reservoir to flow freely to pumps (preferably on transom or on forward engine compartment wall).

- b. Install reservoir mounting bracket with hardware supplied.

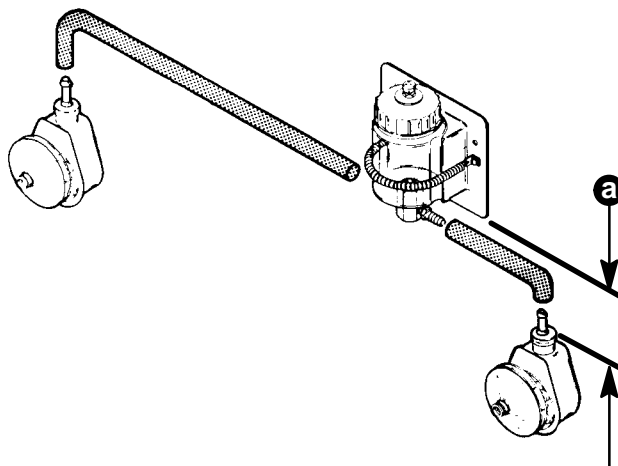

71402

a - measurement - 6 Inch (152 mm) Minimum

2. Position bottle reservoir in mounting bracket and secure with retainer spring.

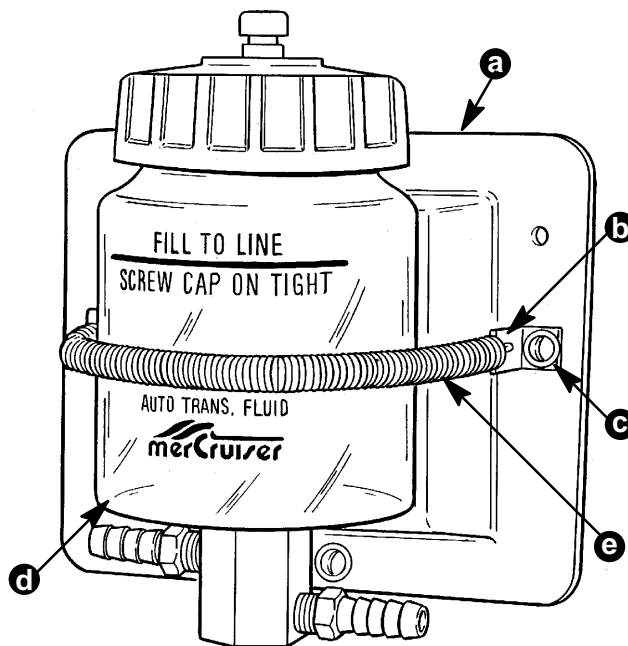

72854

- a - Reservoir Bracket
- b - Reservoir Spring Retainer Tab
- c - Screw and Washer (Not Shown In This View)
- d - Reservoir Bottle
- e - Retainer Spring

IMPORTANT: A two-way valve is required on the reservoir cap for cold weather operation below 40°F (4°C).

3. If required, install two-way valve in reservoir cap by removing vent from cover and replacing it with a two-way check valve.

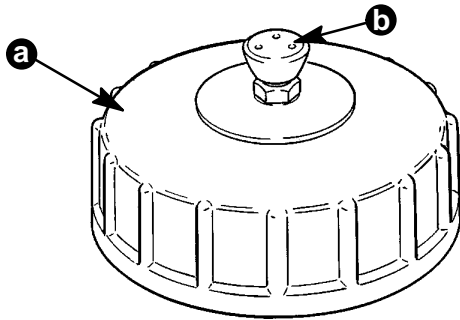

72855

- a - Reservoir Cap
- b - Vent

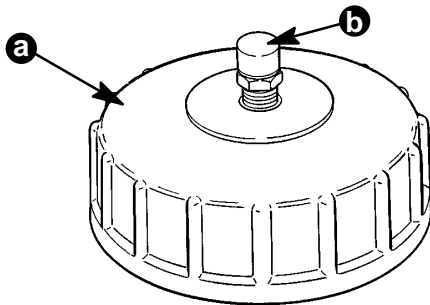

72856

- a - Reservoir Cap
- b - Two-Way Valve (Installed)

4. Cut two hoses (from bulk hose supplied) of sufficient length to extend from bottom fittings on reservoir to fill caps on power steering pumps. Allow extra hose for routing.

IMPORTANT: When routing and installing hoses in the following steps, be sure that the bend radius in the hose is sufficient to eliminate a load being placed on power steering pump fill cap.

5. Connect hoses, that were just cut, to reservoir and power steering pump (from kit). Secure with hose clamps. Tighten securely.

6. Secure hoses with Sta-Straps to keep them below reservoir fluid level line and away from heat and moving parts.

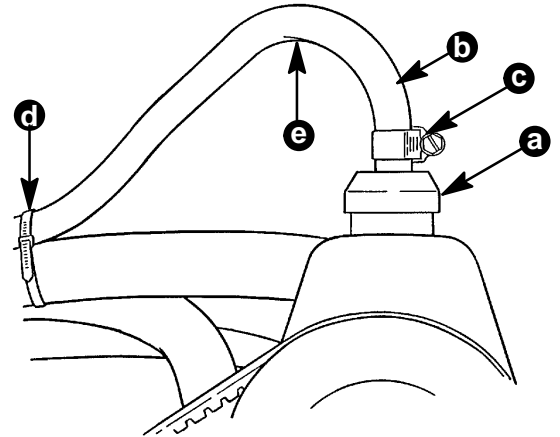

72857

- a - Power Steering Pump Cap (Port and Starboard)
- b - Hose To Reservoir
- c - Hose Clamp
- d - Sta-Straps
- e - Bend Radius (Port and Starboard)

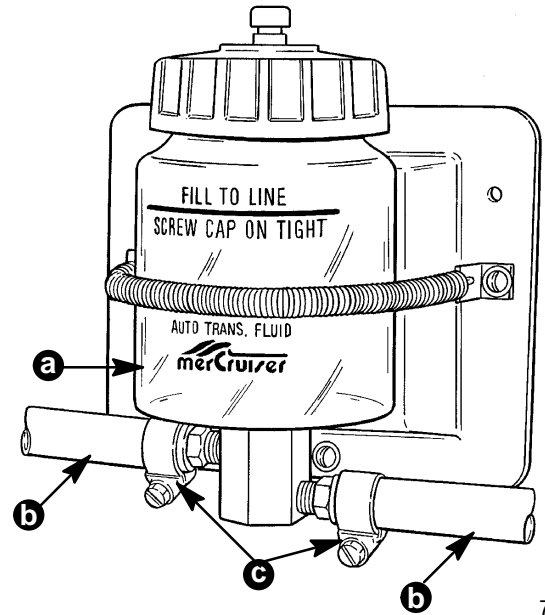

72858

- a - Reservoir
- b - Hoses From Pumps
- c - Hose Clamps

Installing Priority Valve

NOTE: Priority valve mounting bracket can be used in various mounting configurations.

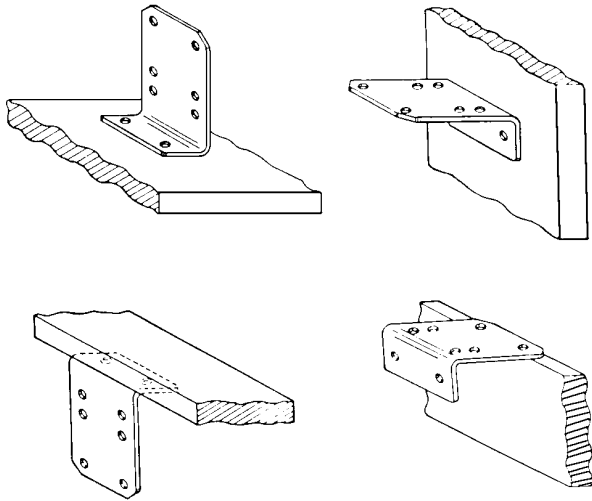

71403

1. Install priority valve mounting bracket.
 - a. Find a central location that will be accessible for making and checking hose connections. Ensure that location will allow 2 in. (51 mm) or more, above and below priority valve for hose connections and routing (preferably on a stringer near transom).
 - b. Mount bracket using lag bolts and washers supplied.

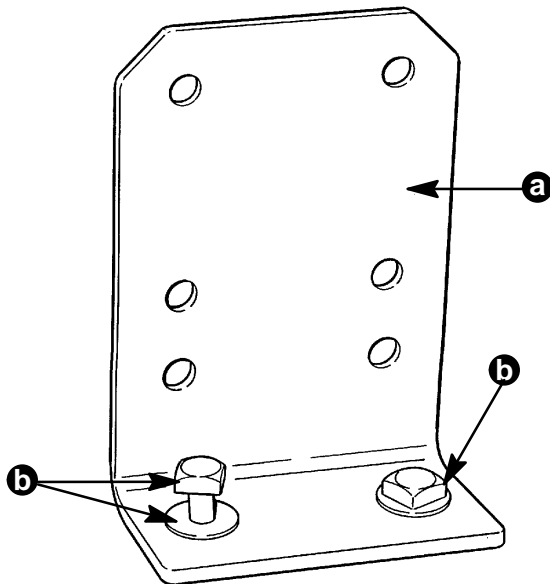

72859

- a - Mounting Bracket
- b - Lag Bolts and Washers

NOTE: The 90° elbow locations on priority valve are marked with a "T" stamped into the valve.

2. Apply liquid pipe joint sealer to threads and install fittings into priority valve.

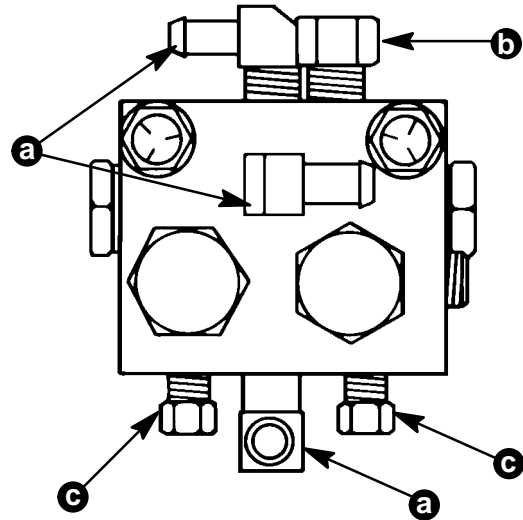

71404

- a - 90 Degree Elbow
- b - Large Inverted Flare Fitting
- c - Small Inverted Flare Fitting

3. Mount priority valve on bracket. Torque bolt to 120 lb. in. (14 N·m).

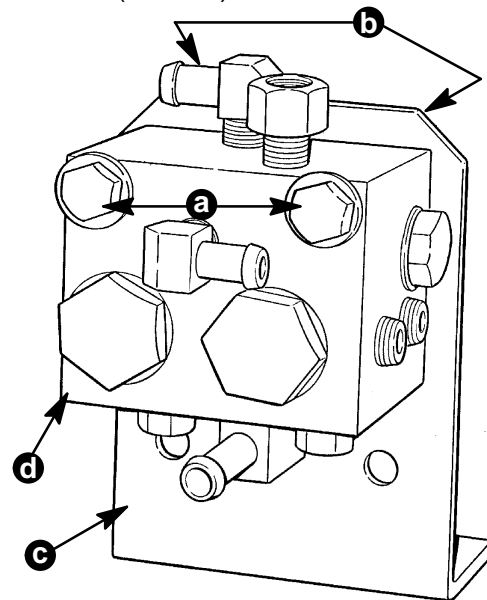

72860

- a - Bolt and Washers
- b - Washer and Nut (Not Shown In This View)
- c - Bracket
- d - Priority Valve

NOTE: Engines with power steering are equipped with a hose that is connected to the power steering fluid cooler. A fitting on the other end of the hose would normally be connected to the power steering control valve. These hoses are not used and are replaced with bulk hose supplied with priority valve kit.

4. Remove and discard old (control valve-to-cooler) hoses which are connected to power steering cooler (port and starboard).
5. Cut two hoses (from bulk hose supplied) of sufficient length to extend from power steering coolers to respective fittings on priority valve.
6. Connect one end of each hose to its respective power steering fluid cooler and other ends to fittings on priority valve. Secure with hose clamps. Tighten securely.

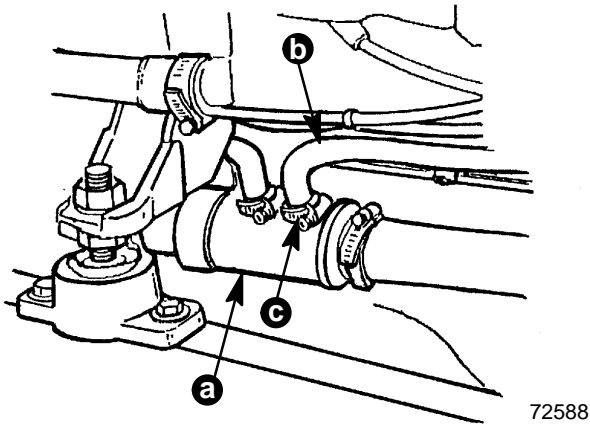

- a - Power Steering Fluid Cooler
- b - Hose
- c - Hose Clamp

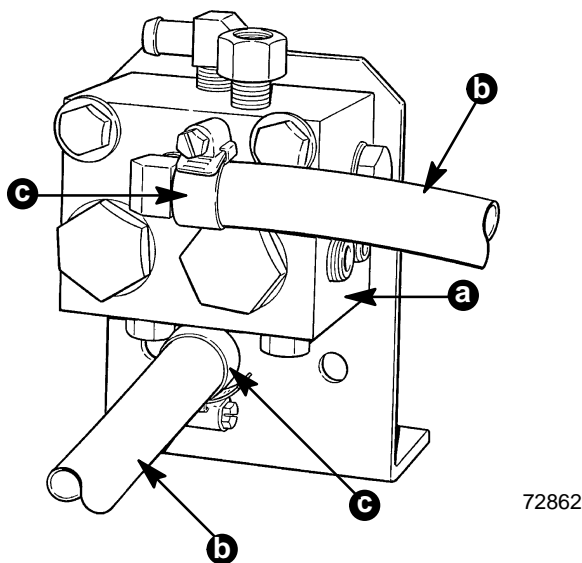

- a - Priority Valve
- b - Hose
- c - Hose Clamp

7. Install return hose (large fitting on one end only,

from kit) to power steering control valve. Route hose to priority valve, cut hose to length, and connect to fitting on priority valve. Secure with hose clamp. Tighten securely.

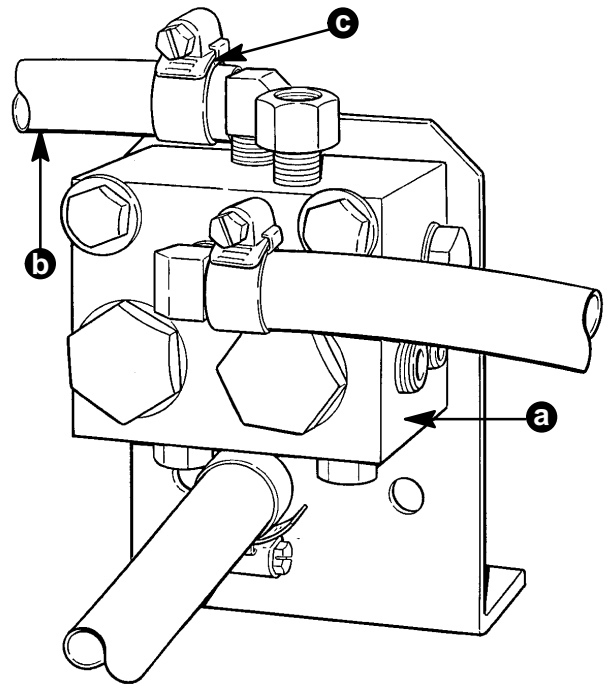
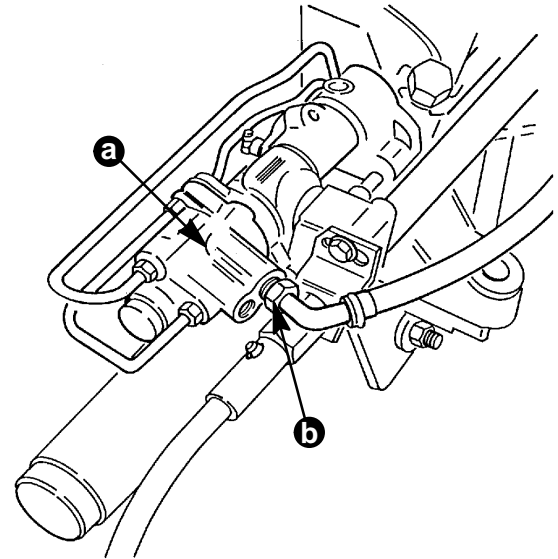

- a - Priority Valve
- b - Hose
- c - Hose Clamp

- Install pressure hose (fittings on both ends, from kit) between power steering control valve and large inverted flare fitting on priority valve. (This fitting location is marked with an "S.") Secure with hose clamp. Tighten securely.

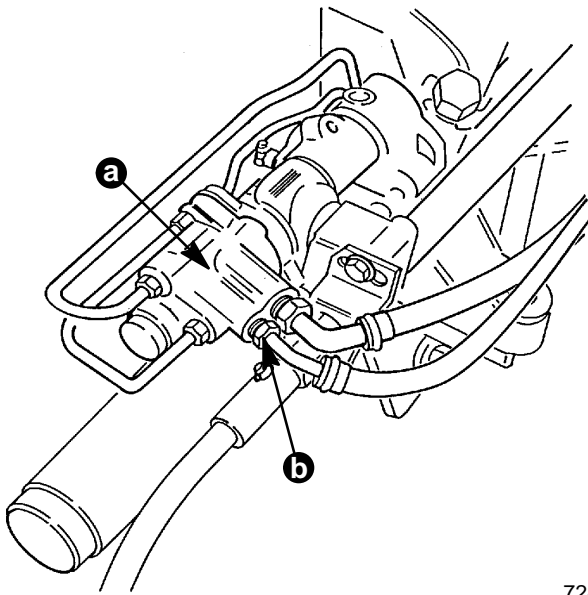

72865

- a - Power Steering Control Valve
- b - Hose Fitting

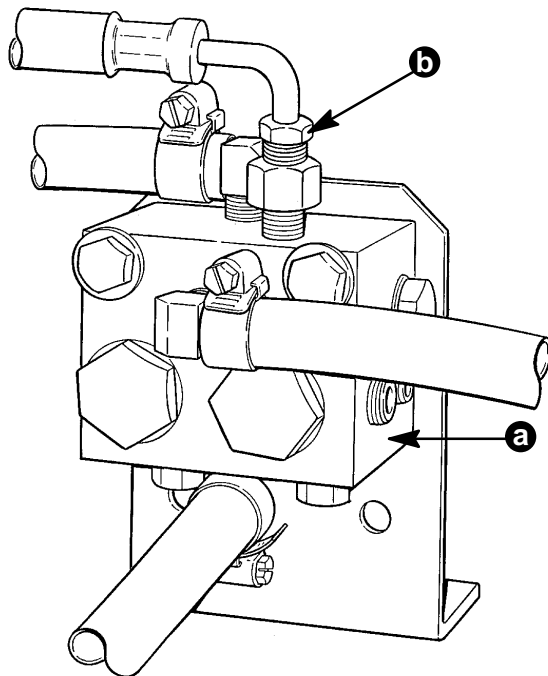

72866

- a - Priority Valve
- b - Hose Fitting

- Connect No. 1 (starboard) engine pressure hose (from pump) to inverted flare fitting marked by "1" on priority valve. Connect No. 2 (port) pressure hose (from pump) to inverted flare fitting marked by "2" on priority valve. Secure with hose clamps. Tighten securely.

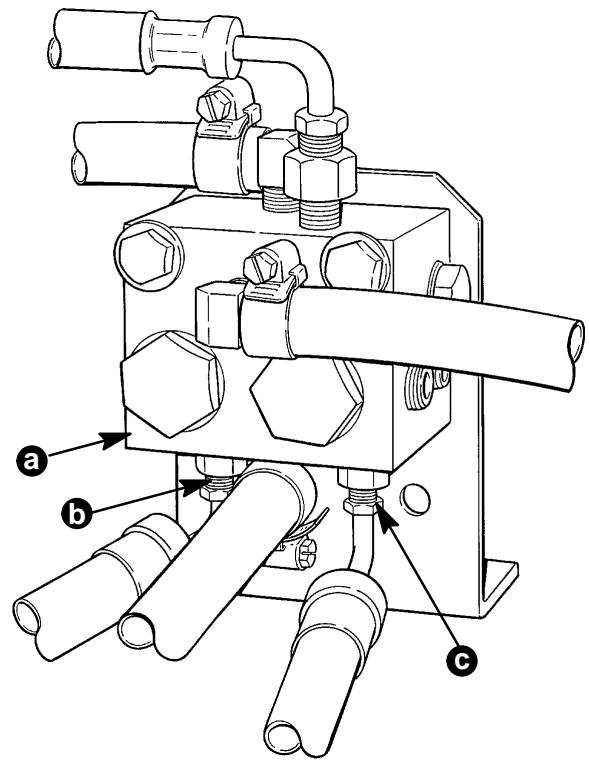

72867

- a - Priority Valve
- b - No. 1 (Starboard) Pressure Hose
- c - No. 2 (Port) Pressure Hose

- Secure all hoses with Sta-Straps provided.

Filling System with Fluid

1. Fill pump reservoirs with automatic transmission fluid (ATF) Dexron II or Dexron III.
2. Install and tighten pump cap by turning cap clockwise approximately 120 degrees.

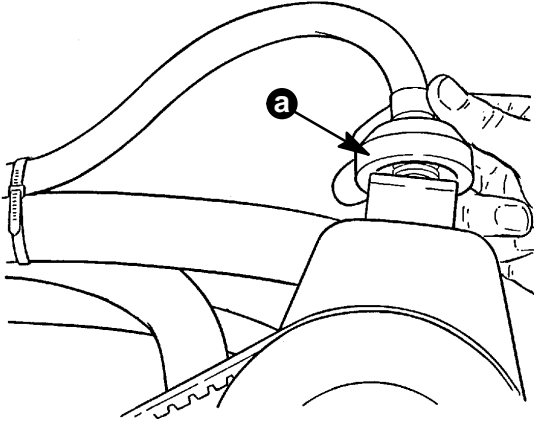

72868

a - Cap

3. Fill reservoir bottle to full mark, then (one at a time) slightly loosen pump cap to allow fluid to flow from reservoir to pump until pump just starts to overflow, then quickly tighten pump cap. Fill bottle reservoir and repeat this process for the other pump.
4. Double check both caps to ensure they are both tight.

Maintenance

Maintenance inspection is the owner's responsibility and must be performed at the following intervals:

Normal Service - Every 50 hrs. of operation or 60 days (whichever comes first)

Severe Service - Every 25 hrs. of operation or 30 days (whichever comes first)

NOTE: Operation in salt water is considered severe service.

1. Check all connections and hose clamps for adequate tightness. Tighten, if loose.
2. Check all mounting bolts and tighten if necessary.
3. Be sure to check reservoir oil level periodically.

System Flow Diagram

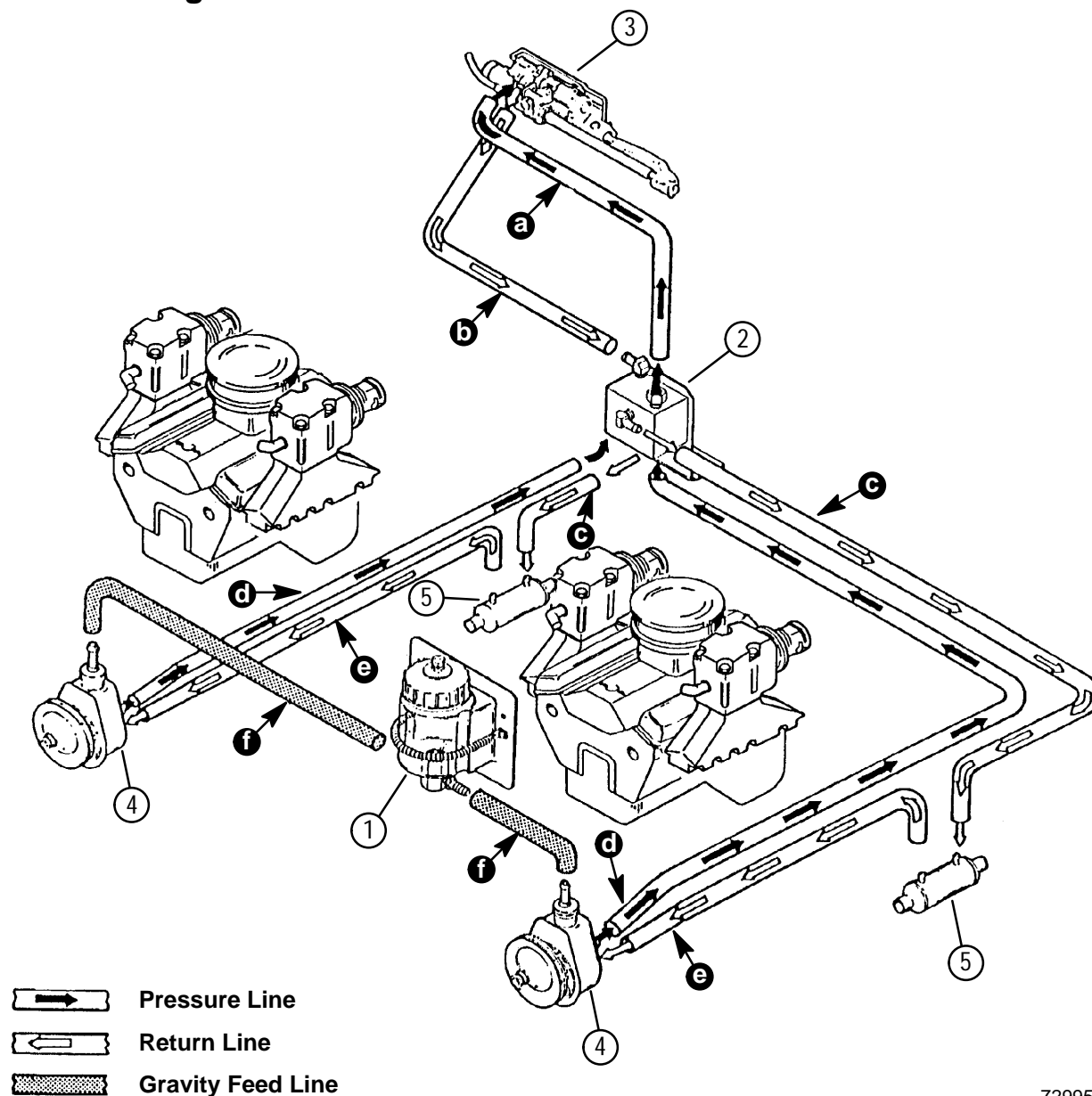

72995

- 1 - Reservoir Bottle and Bracket
- 2 - Priority Valve and Mounting Bracket
- 3 - Power Steering Control Valve
- 4 - Power Steering Pump
- 5 - Power Steering Fluid Cooler

- a - Pressure Hose (Fitting On Both Ends - Supplied In Kit)
- b - Return Hose (Fitting On One End - Supplied In Kit)
- c - Return Hose From Pump (Cut From Bulk Hose Supplied)
- d - Pressure Hose From Pump
- e - Return Hose From Pump
- f - Gravity Feed Hose (Cut From Bulk Hose Supplied)

**THIS PAGE IS INTENTIONALLY BLANK TO
ALLOW FOR CORRECTIONS OR ADDITIONS
AT A LATER DATE**

Free Manuals Download Website

<http://myh66.com>

<http://usermanuals.us>

<http://www.somanuals.com>

<http://www.4manuals.cc>

<http://www.manual-lib.com>

<http://www.404manual.com>

<http://www.luxmanual.com>

<http://aubethermostatmanual.com>

Golf course search by state

<http://golfingnear.com>

Email search by domain

<http://emailbydomain.com>

Auto manuals search

<http://auto.somanuals.com>

TV manuals search

<http://tv.somanuals.com>