

# OPERATOR'S MANUAL

INCLUDING: OPERATION, INSTALLATION & MAINTENANCE

ALSO INCLUDE MANUALS: 6711X-X PUMP, 651615 SINGLE POST LIFT/RAM & FM 3637-2 GEN INFO SHEET

# 650532-X

# 650533-X

RELEASED: 3-6-95  
(REV. A) IPP

3" AIR MOTOR  
21.7:1 RATIO  
2 1/4" STROKE

**650532-1**  
CARBON STEEL

**650533-1**  
STAINLESS STEEL

## PUMP SYSTEM



READ THIS MANUAL CAREFULLY BEFORE INSTALLING,  
OPERATING OR SERVICING THIS EQUIPMENT.

### SERVICE KITS

- Use only genuine ARO replacement parts to assure compatible pressure rating and longest service life.
- 637066-B for repair of Air Motor Section.
- 63729X-XXX for repair of Lower Pump 6710X-X.

### GENERAL DESCRIPTION

**⚠ WARNING** DO NOT EXCEED MAXIMUM OPERATING PRESSURE OF 3,262 P.S.I. (224.9 BAR) AT 150 P.S.I. (10.4 BAR) AIR INLET PRESSURE.

**⚠ WARNING** REFER TO GENERAL INFORMATION SHEET FOR ADDITIONAL SAFETY PRECAUTIONS AND IMPORTANT INFORMATION.

By delivering a smooth, continuous bead of the proper size, an ARO system helps the operator maintain both his production rate and produce quality standards. Maintained quality standards assures that the material benefits are realized. To further maximize operator production time, the ARO System has a built-in lift/ram feature for quick and easy drum changeover.

ARO Systems are totally enclosed, sealing the material in the system from air and moisture, preventing premature cure-out of the material. This allows for either continuous or intermittent use of the system and reduces the need for daily system clean-up.

Built-in lift capability allows for quick drum changeover and easy lifting of pump assembly from container.

The 21.7:1 ratio is an expression of the relationship between the effective air motor area and the effective lower pump area. When 150 PSI (10 bar) of air pressure is supplied to the air motor, the lower pump area will develop a maximum of 3,262 PSI (224.9 bar) of fluid pressure (at no flow) as the fluid control is opened, the flow rate will increase as the air motor cycle rate increases to keep up with the demand

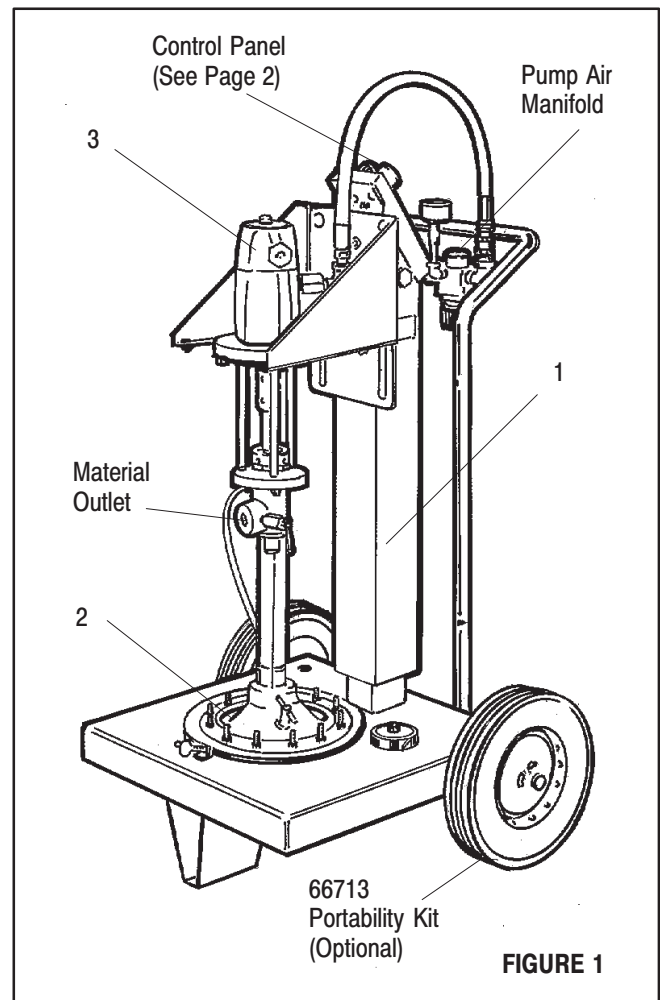

### MAJOR COMPONENTS LIST

Item	Description	Qty	Part No.	Item	Description	Qty	Part No.
1	Single Post Ram	1	651615	3	Basic Pump Assembly (650532-1)	1	67110-P43
2	Follower Plate (650532-1)	1	651840-1		Basic Pump Assembly (650533-1)	1	67111-P43
	Follower Plate (650533-1)	1	651841-1	OPTIONAL EQUIPMENT			
					Portability Kit		66713

THE ARO CORPORATION • ONE ARO CENTER • BRYAN, OHIO 43506-0151

☎ (419) 636-4242 • FAX (419) 636-2115

© 1995 THE ARO CORPORATION • PRINTED IN U.S.A.



Part of worldwide Ingersoll-Rand

## INSTALLATION

The 65053X-X Chop-Check Dispensing System comes completely assembled. Remove unit from crate and place on a level surface. Install material hose and dispensing device as required.

When the following instructions are observed, heavy paste materials can be pumped directly from their original 5 gallon drum without air in-

clusion, or excessive waste. The follower plate creates an air tight seal as well as clean-wiping action in its progressive downward movement into the drum.

## OPERATING INSTRUCTIONS

### OPERATING INSTRUCTIONS / INITIAL SETUP PROCEDURE

**⚠ WARNING** **STAND CLEAR.** When raising or lowering the lift. Read the warning on page 2 of 651615 Single Post Lift/Ram Operator's Manual.

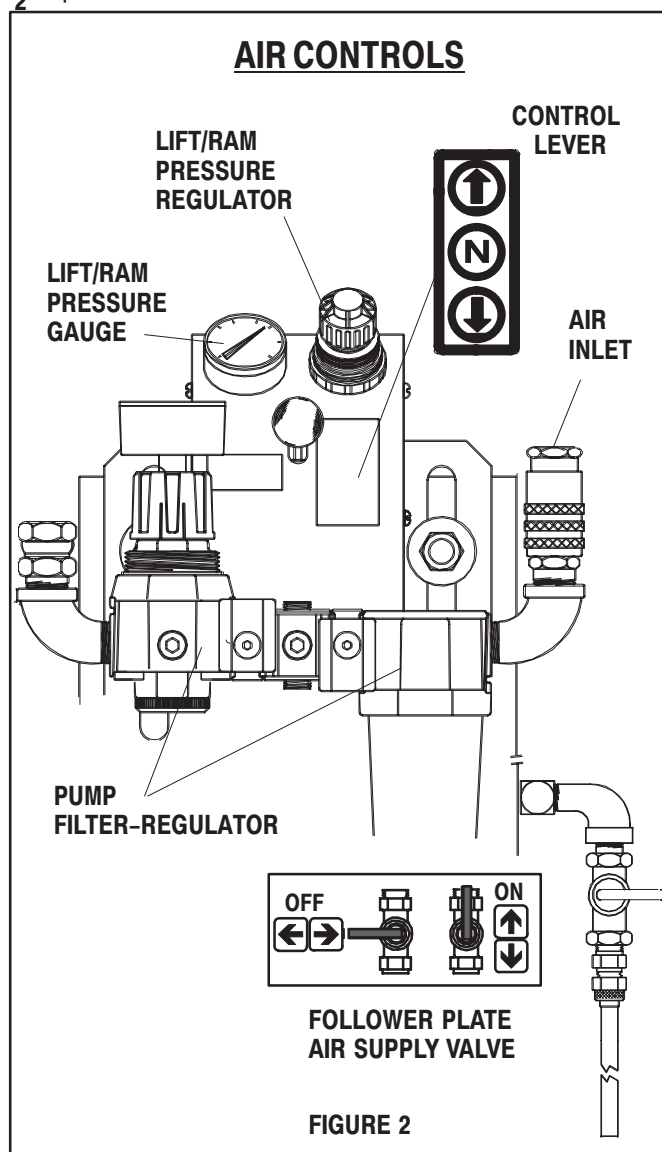

### TO RAISE LIFT, (THE FIRST TIME):

1. Take note of the pump/drum clearance above. Be certain the lift is clear of any objects above. Also refer to OPERATING AND SAFETY PRECAUTIONS found on page 2 of 651615 Single Post Lift/Ram Operator's Manual.
2. Connect the air supply (160 PSI MAX) to the air inlet. Adjust (Turn Lift/Ram Pressure Regulator Knob Clockwise) air pressure on lift/ram pressure regulator to 20 P.S.I. (1.2 Bar)
3. Shift the control valve lever to the "UP" position.
4. Raise the lift high enough to clear the height of the drum. Stop the lift upward travel by moving the control valve lever to the (center) "NEUTRAL" position.

### REFER TO PAGE 3:

1. Once lift assembly and pump are in the "UP" position, place and center an opened 5 gallon drum of material on the lift/ram base. Use the stops on the base to center 5 gallon drum. Tighten thumb screw to secure drum.
2. Lubricate lower follower wiper plate seal with any type grease. (silicone, vaseline, gear, etc.) This ensures a smooth fit into the pail as well as prevents curing type compounds from bonding to seal.
3. Check vent plug on follower plate to be sure it easily threads in and out. It is recommended to lubricate the threads of the plug to help prevent possible set up of compound at this point. **See 65184X-X Operator's Manual.**

### TO LOWER LIFT:

**⚠ WARNING** **PINCH HAZARD.** Follower can descend quickly causing injury. Keep hands clear when aligning with container. Read the warning on page 2 of 651615 Single Post Lift/Ram Operator's Manual..

**NOTE:** Be certain the Follower Plate vent plug has been removed so that the air trapped between the follower and the material is allowed to escape from this vent. Captured air between the follower plate and drum will escape.

**NOTE:** The lift may hesitate momentarily before starting downward, the air pressure inside the post air chamber must decrease before it will begin to descend.

1. Shift the control valve lever to the "DOWN" position and proceed to lower the pump.
2. Replace the vent plug once the material begins to ooze from the vent opening.
3. The unit is now ready for operation. Adjust (Turn pump regulator Clockwise) air pressure on pump Filter/Regulator until pump begins to cycle.
4. Trigger gun to prime pump with material.

### TO RAISE LIFT, (NORMAL OPERATION):

1. Adjust the Follower Plate Air Valve pressure up to approximately 8 psig. **DO NO OVERPRESSURIZE THE DRUM** to avoid damage. **NOTE:** Air from this valve will only pass when the Control Lever is in the "UP" position.
2. Shift the control valve lever to the "UP" position.
3. Raise the lift high enough to clear the height of the drum. Stop the lift upward travel by moving the control valve lever to the (center) "NEUTRAL" position.

### TO CHANGE DRUM:

**NOTE:** The Control Lever should be in the "NEUTRAL" position.

1. Unscrew thumb screw and remove old 5 gallon drum.
2. Place and center a new drum into position. Remove cover. Tighten thumb screw.

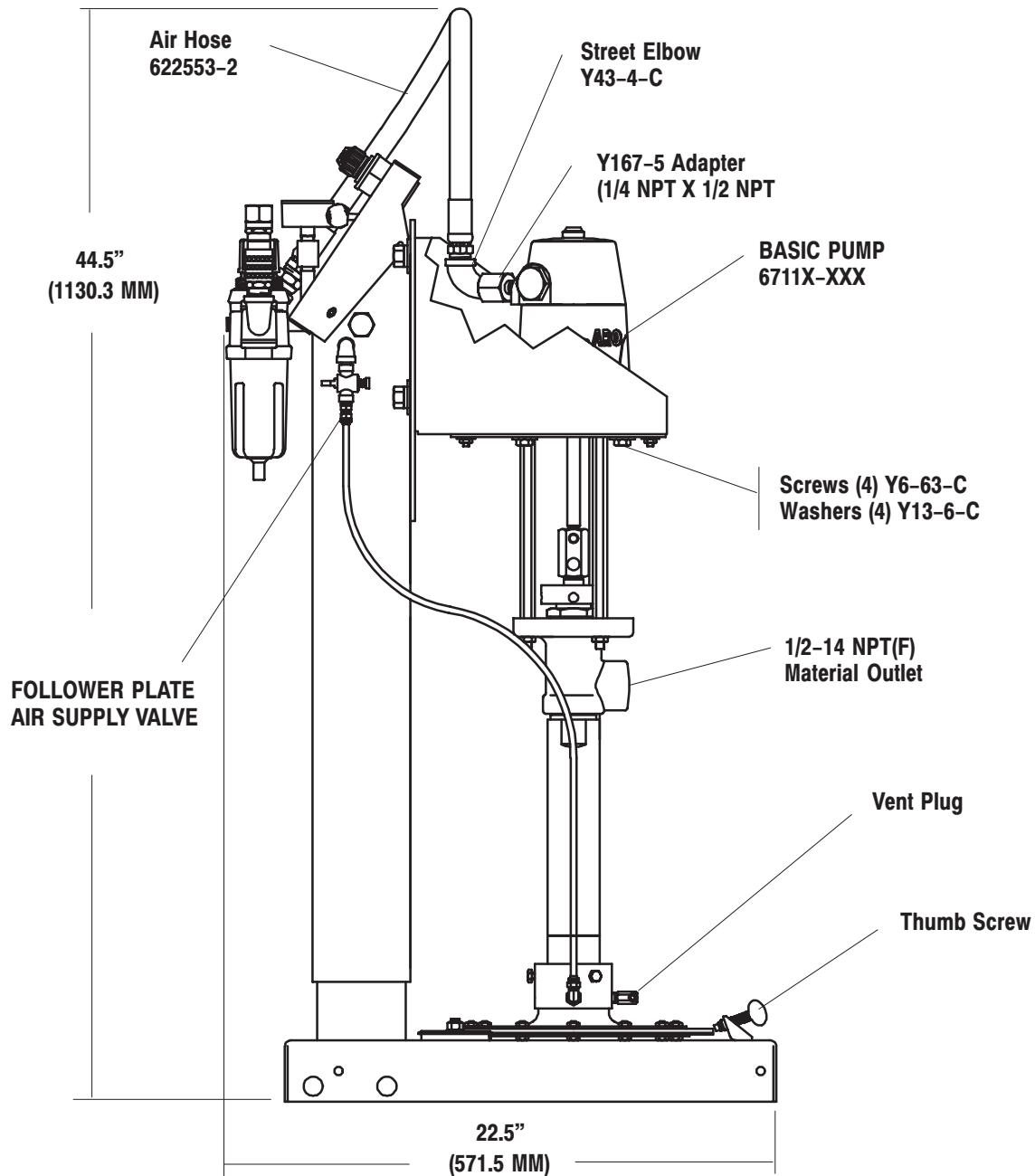
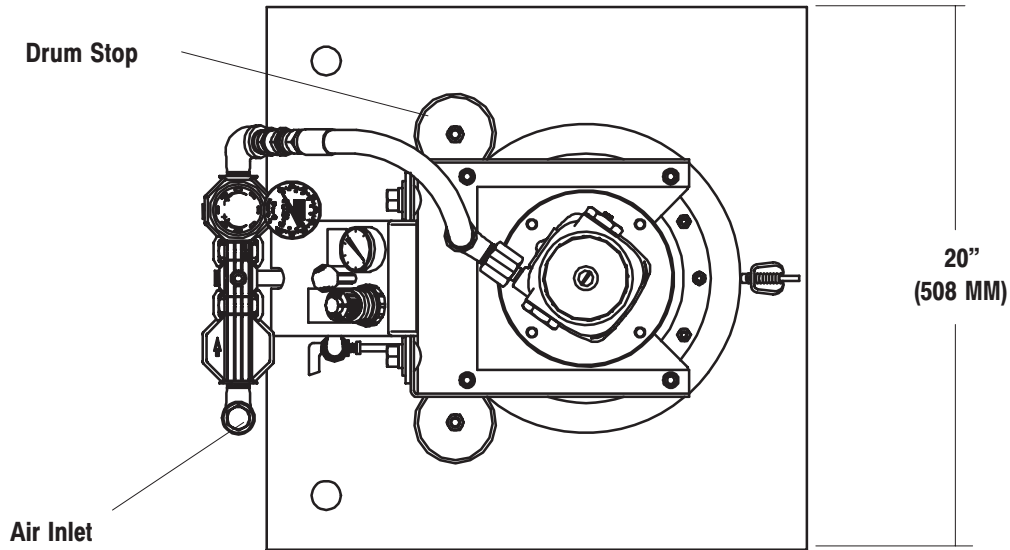

FIGURE 3



Part of worldwide Ingersoll-Rand

PN 97999-607

## Free Manuals Download Website

<http://myh66.com>

<http://usermanuals.us>

<http://www.somanuals.com>

<http://www.4manuals.cc>

<http://www.manual-lib.com>

<http://www.404manual.com>

<http://www.luxmanual.com>

<http://aubethermostatmanual.com>

Golf course search by state

<http://golfingnear.com>

Email search by domain

<http://emailbydomain.com>

Auto manuals search

<http://auto.somanuals.com>

TV manuals search

<http://tv.somanuals.com>