

# OPERATOR'S MANUAL

# 650875-X-B

SPECIFICATIONS, SERVICE KITS, GENERAL INFORMATION, TROUBLESHOOTING

INCLUDE MANUALS: 66236-X-B LOWER PUMP END (PN 97999-489) & S-632 GENERAL INFORMATION MANUAL (PN 97999-624)

RELEASED: 5-25-96

REVISED: 6-9-10

(REV. D)

10" AIR MOTOR  
20:1 RATIO  
6" STROKE

## 650875-XX4-B EXTRUSION PUMP SERIES (CARBON STEEL)



READ THIS MANUAL CAREFULLY BEFORE INSTALLING,  
OPERATING OR SERVICING THIS EQUIPMENT.

### SERVICE KITS

- Use only genuine ARO® replacement parts to assure compatible pressure rating and longest service life.
- **637110 for repair of Air Motor section.**  
Service Note: The Air Motor Service/Parts Manual is not shipped with the pump but it is included with each Service Kit. If this Service/Parts Information is needed, request the Air Motor Operator's Manual from ARO. (Manual 66651, Pn 97999-110).
- **637128-XXX-B for repair of Lower Pump section.**  
Refer to the chart on page 2 for description of -XXX options.

### SPECIFICATIONS

<b>Model Series</b> (Refer to option chart)	650875-XX4-B
<b>Type</b>	Air Operated, Extrusion
<b>Ratio</b>	20:1
<b>Air Motor</b>	66651
<b>Motor Repair Kit</b>	637110
<b>Motor Diameter</b>	10" (25.4 cm)
<b>Stroke</b>	6"
<b>Air Inlet</b>	3/4" - 14 NPTF - 1(f)
<b>Air Exhaust</b>	1-1/4", 11-1/2 NPTF - 1(f)
<b>Lower Pump End Series</b>	66236-XX4-B
<b>Lower Pump Repair Kit</b>	637128-XX4-B
<b>Material Inlet</b>	Shovel type
<b>Material Outlet</b>	1-1/2", 11-1/2 NPTF - 1(f)

### PERFORMANCE

<b>Air Inlet Pressure Range</b>	30 - 90 PSI (2 - 6.2 bar)
<b>Fluid Pressure Range</b>	600 - 1800 PSI (41.3 - 124 bar)
<b>Max. Rec'd Cycles / Minute</b>	60
<b>Displacement In<sup>3</sup> Per Cycle</b>	40.4
<b>Cycles Per Gallon</b>	5.7
<b>Flow @ 60 Cycles / Minute</b>	10.5 G.P.M. (39.7 lpm)
<b>Noise Level @ 60 Psi - 40 Cpm</b>	84.8 db(A) *

\* The pump sound pressure level has been updated to an Equivalent Continuous Sound Level ( $L_{Aeq}$ ) to meet the intent of ANSI S1. 13-1971, CAGI-PNEUROP S5.1 using four microphone locations.

### PUMP DATA

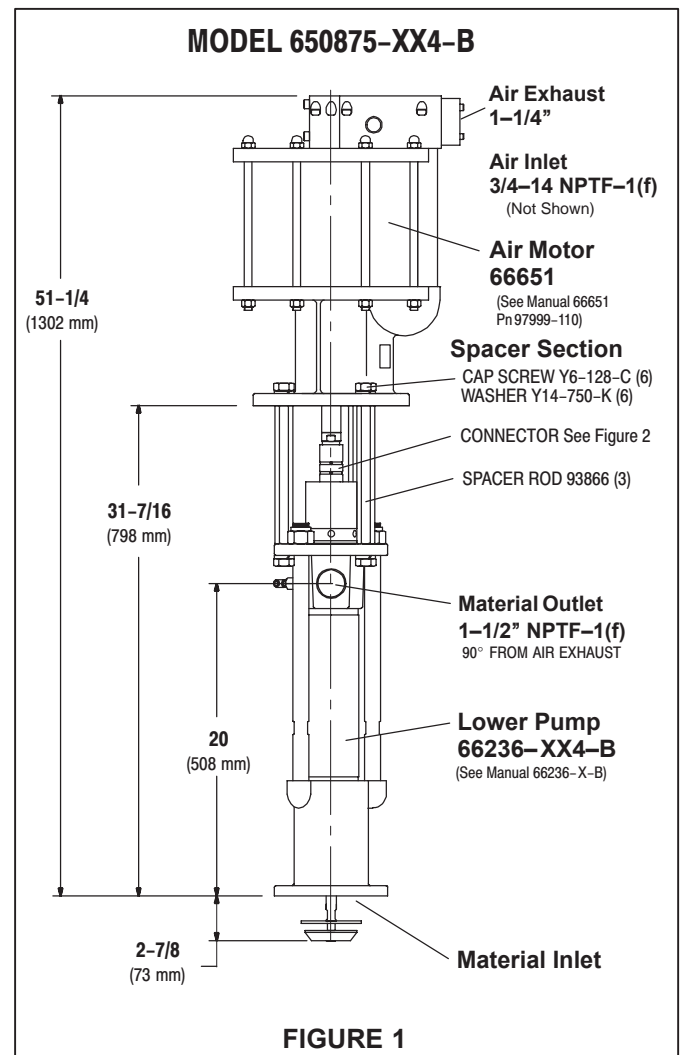

### IMPORTANT

This is one of the four documents which support the pump.  
Replacement copies of these forms are available upon request.

- 650875-XX4-B MODEL OPERATOR'S MANUAL
- GENERAL INFORMATION - INDUSTRIAL PISTON PUMPS
- 66236-X-B LOWER PUMP END OPERATOR'S MANUAL
- 66651 AIR MOTOR OPERATOR'S MANUAL

INGERSOLL RAND COMPANY LTD

209 NORTH MAIN STREET - BRYAN, OHIO 43506

☎ (800) 495-0276 • FAX(800) 892-6276

www.ingersollrandproducts.com

© 2010

# ARO

**IR** Ingersoll Rand  
Industrial Technologies

# PUMP OPTION DESCRIPTION CHART

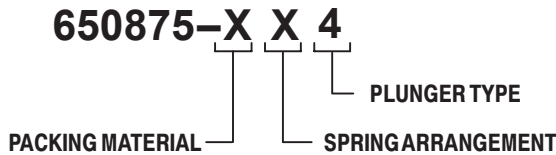

## PACKING MATERIAL

3 GLASS FILLED BF87  
 C UHMW-PE  
 F UHMW-PE/LEATHER STAG'D (UPPER)  
 UHMW-PE (LOWER)

## SPRING ARRANGEMENT

3 NO SPRING  
 4 MULTIPLE WAVE SPRING

(PACKINGS ARE UPPER AND LOWER UNLESS NOTED)

J POLYURETHENE (UPPER)  
 UHMW-PE (LOWER)  
 P G: ? I ZB7 BF87 EF39y6 / GBB7Dfi  
 UHMW-PE (LOWER)  
 R BF87 G: ? I ZB7 EF39y6 / GBB7Dfi  
 BF87->A1 7Dfi

## PLUNGER TYPE

4 CS W/HD CHROME PLATING

## GENERAL DESCRIPTION

**⚠ WARNING** HAZARDOUS PRESSURE. Do not exceed maximum operating pressure of 2250 psi (157 bar) at 90 psi (6.3 bar) inlet air pressure.

**PUMP RATIO X  
 INLET PRESSURE TO PUMP MOTOR = MAXIMUM PUMP  
 FLUID PRESSURE**

Pump ratio is an expression of the relationship between the pump motor area and the lower pump end area. EXAMPLE: When 150 p.s.i. (10.3 bar) inlet pressure is supplied to the motor of a 6:1 ratio pump it will develop a maximum of 750 p.s.i. (52 bar) fluid pressure (at no flow) – as the fluid control is opened, the flow rate will increase as the motor cycle rate increases to keep up with the demand.

**⚠ WARNING** Refer to general information sheet for additional safety precautions and important information.

- The Extrusion (Chop-Check) pumps are primarily designed for the pumping of heavy viscous materials with fibrous content. The models can be used with a gravity feed single post lift as a topper type assembly or with a two post lift as a force feed type assembly. The lower pump is designed for easy priming and the double acting feature is standard in all ARO industrial pumps. Material is delivered to the pump discharge outlet on both the up and down stroke.
- The motor is connected to the lower pump end by a spacer section. This allows for lubrication of the upper packing gland and prevents motor contamination because of normal wear and eventual leakage through the material packing gland. Be sure the solvent cup is adequately filled with lubricant to protect the upper packings and insure longest service life.

## TROUBLE SHOOTING

Pump problems can occur in either the Air Motor Section or the Lower Pump End Section, use these basic guidelines to help determine which section is affected.

### If the pump will not cycle.

- Be certain to first check for non-pump problems including kinked, restrictive or plugged inlet/outlet hose or dispensing device. Depressurize the pump system and clean out any obstructions in the inlet/outlet material lines.
- Refer to the motor manual for trouble shooting if the pump does not cycle and/or air leaks from the air motor.

### If the pump cycles but does not deliver material.

- Refer to the lower pump end manual for further trouble shooting.

## PUMP CONNECTION – UPPER / LOWER

**NOTE: All threads are right hand.**

- Lay the pump assembly on a workbench.
- Remove the three nuts from the three spacer rods. (Fig. 1)
- Pull the air motor from the lower pump end until motor piston rod is in the “down” position and lower pump end rod is in “up” position.
- Remove the cotter pins and unthread piston rods from the connector. (Fig. 2)

### PUMP CONNECTOR DETAIL

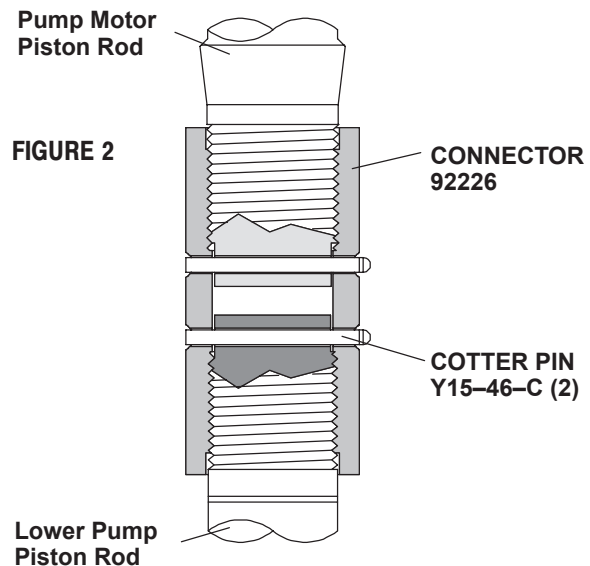

### REASSEMBLY

- Thread connector to pump motor piston rod until hole thru connector is aligned with hole thru piston rod.
- Assemble cotter pin thru hole and bend ends of pin into groove of connector.
- Thread connector to lower pump piston rod until hole thru connector is aligned with hole thru piston rod.
- Assemble cotter pin thru hole and bend ends of pin into groove of connector.
- Note: Heads and ends of cotter pins must not extend more than .125” beyond o.d. of connector.
- Reinstall the spacer rods to the pump motor.
- Bring the motor and lower pump together and retain with the three nuts.

## Free Manuals Download Website

<http://myh66.com>

<http://usermanuals.us>

<http://www.somanuals.com>

<http://www.4manuals.cc>

<http://www.manual-lib.com>

<http://www.404manual.com>

<http://www.luxmanual.com>

<http://aubethermostatmanual.com>

Golf course search by state

<http://golfingnear.com>

Email search by domain

<http://emailbydomain.com>

Auto manuals search

<http://auto.somanuals.com>

TV manuals search

<http://tv.somanuals.com>